

Schneider Inverter

HY5K1EU1, HY6K1EU1, HY8K1EU1

Installation and Operation Guide



Legal Information

The Schneider Electric brand and any trademarks of Schneider Electric SE and its subsidiaries referred to in this guide are the property of Schneider Electric SE or its subsidiaries. All other brands may be trademarks of their respective owners.

This guide and its content are protected under applicable copyright laws and furnished for informational use only. No part of this guide may be reproduced or transmitted in any form or by any means (electronic, mechanical, photocopying, recording, or otherwise), for any purpose, without the prior written permission of Schneider Electric.

Schneider Electric does not grant any right or license for commercial use of the guide or its content, except for a non-exclusive and personal license to consult it on an "as is" basis. Schneider Electric products and equipment should be installed, operated, serviced, and maintained only by qualified personnel.

As standards, specifications, and designs change from time to time, information contained in this guide may be subject to change without notice.

To the extent permitted by applicable law, no responsibility or liability is assumed by Schneider Electric and its subsidiaries for any errors or omissions in the informational content of this material or consequences arising out of or resulting from the use of the information contained herein.

Contact Information

For country-specific details, please contact your local Schneider Electric Sales Representative or visit the Schneider Electric website at: <https://www.se.com/>

Information About Your System

As soon as you open your product, inspect the contents and record the following information and be sure to keep your proof of purchase. If any damage is found, contact customer support.

Serial Number _____ Purchased From _____

Product Number _____ Purchase Date _____

Document Number: TME38690A

Date: October 2024

Information on Non-Inclusive or Insensitive Terminology

As a responsible, inclusive company, Schneider Electric is constantly updating its communications and products that contain non-inclusive or insensitive terminology. However, despite these efforts, our content may still contain terms that are deemed inappropriate by some customers.

Validity Note

This document is valid only for the Schneider Inverter HY5K1EU1, HY6K1EU1, and HY8K1EU1.

If this manual is in any language other than English, although steps have been taken to maintain the accuracy of the translation, the accuracy cannot be guaranteed. Approved content is contained with the English language version which is posted at <https://www.se.com/>.

The characteristics of the products described in this document are intended to match the characteristics that are available on <https://www.se.com/>. As a part of our corporate strategy for constant improvement, we may revise the content over time to enhance clarity and accuracy. If you see a difference between the characteristics in this document and the characteristics on <https://www.se.com/>, consider <https://www.se.com/> to contain the latest information.

Safety Information

Important Information

Read these instructions carefully and look at the equipment to become familiar with the device before trying to install, operate, service or maintain it. The following special messages may appear throughout this documentation or on the equipment to warn of potential hazards or to call attention to information that clarifies or simplifies a procedure.

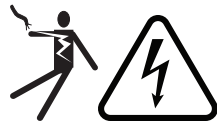

The addition of either symbol to a “Danger” or “Warning” safety label indicates that an electrical hazard exists which will result in personal injury if the instructions are not followed.



This is the safety alert symbol. It is used to alert you to potential personal injury hazards. Obey all safety messages that follow this symbol to avoid possible injury or death.



Stored energy hazard and discharge time



Hot surface



Protective Earth (grounding) conductor terminal



Refer to the Installation or Operation instructions

DANGER

DANGER indicates a hazardous situation which, if not avoided, **will result in** death or serious injury.

WARNING

WARNING indicates a hazardous situation which, if not avoided, **could result in** death or serious injury.

CAUTION

CAUTION indicates a hazardous situation which, if not avoided, **could result in** minor or moderate injury.

NOTICE

NOTICE is used to address practices not related to physical injury.

Audience

This manual is intended for use by qualified personnel installing and operating a system involving Schneider Inverter.

The qualified personnel have training, knowledge, and experience in:

- Installing electrical equipment.
- Applying all applicable installation codes.
- Analyzing and reducing the hazards involved in performing electrical work.
- Selecting and using Personal Protective Equipment (PPE).

Contents

Legal Information	2
Contact Information	2
Information About Your System	2
Information on Non-Inclusive or Insensitive Terminology	2
Validity Note	3
Audience	5
Scope	12
Abbreviations and Acronyms	12
Related Information	13
Related Documents	13
Product Safety Information	14
READ AND SAVE THESE INSTRUCTIONS - DO NOT DISCARD	14
Limitations on Use	19
Explosive Gas Precautions	19
Overview	21
System Connection Diagram	21
What's in the Box	22
Physical Features	23
Dimensions	23
Related Products	24
Required Accessory	25
Required Power Meter	25
Related Installer Web Portal	25
Required Installer App	25
Related Home Owner App	26
Cybersecurity Guidelines	27
Pre-Installation	31
Planning the Installation	31
Required Tools and Materials	31
Location	33
Mounting Surface Requirements	34
Clearance Requirements	35
Installing the Inverter	37
Guidelines for Routing Cables	37
Lock-Out and Tag-Out (LOTO) Procedure	38
Installing the Mounting Bracket	40
Mounting the Inverter	41

Wiring Instructions	42
Protective Earth (PE) Ground Connection	42
PV Cable Connections	44
Battery Cable Connections	47
AC Cable Connections	49
Communication Cable Connections	53
Installing the PowerTag Resi9 80 A (R9M80X6M) (PTE6) Meter (Spain)	57
Connecting Your Device for Commissioning	60
Commissioning	61
Commissioning Checklist	62
Start-Up	63
Operating the Inverter	68
Zero Export Mode	68
Front Panel LED Indicators	68
Monitoring Operation with the Schneider Electric Installer Portal	70
Accessing Installer Portal	71
Selecting a language	71
Adding a Site	72
Configuring Export Mode	73
Viewing Events in the Installer Portal	74
Viewing Firmware Information	76
Troubleshooting	77
General Troubleshooting Steps	77
Contacting Technical Support (Spain)	77
Troubleshooting and Event List	78
Maintenance	82
Turning Off the Inverter	82
Routine Maintenance	82
Safety Inspection	82
Disassembling and Decommissioning	83
Storage and Transportation	83
Recycling and Disposal	83
Specifications	86

Figures

Figure 1 System connection diagram (Spain)	21
Figure 2 Package contents	22
Figure 3 Physical features	23
Figure 4 Inverter dimensions	23
Figure 5 Clearance requirements	35
Figure 6 Mark the wall	40
Figure 7 Install expansion bolts	40
Figure 8 Connect mounting bracket and inverter	41
Figure 9 Earth connection	43
Figure 10 AC connector accessories	50
Figure 11 Wire stripping specifications	50
Figure 12 AC cable assembly	51
Figure 13 AC connector pin definition	51
Figure 14 AC inverter connection	52
Figure 15 Inverter, Boost and Energy Monitor communication wiring (Spain)	53
Figure 16 Communication cable pin definition	54
Figure 17 Communication connector accessories	55
Figure 18 Communication wire strip length	55
Figure 19 Communication cable	56
Figure 20 Communication port	56
Figure 21 Mount the meter on the DIN rail	57
Figure 22 Current transformer wiring	57
Figure 23 PTE6 connection diagram	58
Figure 24 Location of serial number on inverter	60
Figure 25 Monitoring sites with the Installer Portal	70
Figure 26 Language menu	71
Figure 27 Export configuration	73
Figure 28 All sites menu	74
Figure 29 Viewing site events	74
Figure 30 Events menu	74
Figure 31 Event filters	75
Figure 32 Viewing firmware information	76

Tables

Table 1 One Phase specifications for Spain	24
Table 2 AC Protection device requirements for Spain	24
Table 3 PV DC Box protection device requirements for Spain	24
Table 4 Software requirements	25
Table 5 Clearance requirements	35
Table 6 PV cable specifications	44
Table 7 Battery cable specifications	47
Table 8 AC cable specifications	50
Table 9 Communication cable specifications	55
Table 10 PTE6 meter wiring	58
Table 11 Troubleshooting steps	65
Table 12 Service Protocol definitions	79
Table 13 Routine maintenance	82

About

Scope

This manual contains instructions for installation, commissioning, maintenance and troubleshooting for Schneider Inverter.

Abbreviations and Acronyms

Abbreviations and Acronyms	
1P	Single-phase
AC	Alternating Current, see also VAC
BMS	Battery Management System
CAN	Controller Area Network
DC	Direct Current, see also VDC
ECB	External Communication Bus
GND	Ground, see also PE
Cellular	Global System for Mobile
IP	Internet Protocol OR Ingress Protection
LAN	Local Area Network
LED	Light Emitting Diode
LOTO	Lock-out and tag-out
LPG	Liquid Petroleum Gas
MCB	Miniature Circuit Breaker
MPPT	Maximum Power Point Tracking
NG	Natural Gas
PE	Protective earth (ground)
PPE	Personal protective equipment
PV	Photovoltaic
RCD	Residual Current Device
RCMU	Residual Current Monitoring Unit
STP	Shield-Twisted Pair
VAC	Volts Alternating Current
VDC	Volts Direct Current
W	Watt
WLAN-FE	Wireless Local Area Network - Fast Ethernet

Related Information

For more information about the inverter, related documents, specifications, and compatible equipment, see <https://www.se.com/>.

Related Documents

- *Schneider Boost Installation and Operation Guide (TME27412)*
- *Wireless LAN Smart Dongle Quick Reference Guide (TME34287)*

For Germany



Scan

or

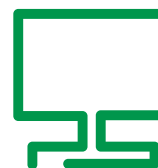

Visit

<https://www.se.com/de/de/product-range/234870270>

For Spain



Scan

or

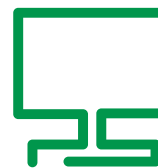

Visit

<https://www.se.com/es/es/product-range/234870270>

Product Safety Information

READ AND SAVE THESE INSTRUCTIONS - DO NOT DISCARD

Before installing or operating the inverter, read all instructions and cautionary markings on the unit, and all appropriate sections of this manual.

IMPORTANT: See your warranty for instructions on obtaining service.

DANGER

HAZARD OF ELECTRIC SHOCK, EXPLOSION, ARC FLASH, AND FIRE

- This equipment must only be installed, configured, and serviced by qualified electrical personnel.
- Qualified electrical personnel must apply appropriate personal protective equipment (PPE), follow safe electrical work practices, and adhere to all applicable local and national electrical codes.
- Do not disassemble, alter the product, or modify the software code without authorization.
- Never operate energized with covers removed.
- Energized from multiple sources. Before working with cables, identify all sources, de-energize, lock-out, and tag-out and wait five minutes for circuits to discharge.
- Always use a properly rated voltage sensing device to confirm that all circuits are de-energized.

Failure to follow these instructions will result in death or serious injury.

DANGER

HAZARD OF ELECTRIC SHOCK, EXPLOSION, ARC FLASH, AND FIRE

- Disconnect the PV panels prior to connecting or disconnecting PV terminals.
- Energized from multiple sources. Before working with cables, identify all sources, de-energize, lock-out, and tag-out and wait five minutes for circuits to discharge.

Failure to follow these instructions will result in death or serious injury.

 **DANGER****UNEARTHED (UNGROUND) EQUIPMENT**

- Equipment earth (ground) terminals must be reliably connected to earth (ground) by appropriately sized protective earth (PE) conductors. All installations must comply with national and local codes. Consult national and local codes for specific earthing (grounding) and bonding requirements.
- When installing this equipment, install a protective earth (PE) wire first. When removing this equipment, the protective earth wire must be removed last.
- Verify that there is no damage to the earthing (grounding) conductor.
- Do not operate the device without an earthing (grounding) conductor installed.
- The device should be permanently connected to protective earth ground, and the protected area. Before operating this equipment, check the electrical earth connection to verify that the equipment is reliably earthed.

Failure to follow these instructions will result in death or serious injury.

 **DANGER****HAZARD OF ELECTRIC SHOCK, EXPLOSION, ARC FLASH, AND FIRE**

- Disconnect negative and positive DC conductors before servicing. DC conductors are to be treated as Hazardous Live and must be disconnected.
- Normally EARTHED (GROUNDED) conductors may be UNEARTHED (UNGROUND) and ENERGIZED when a EARTH (GROUND) FAULT is indicated. Must be serviced by qualified personnel.

Failure to follow these instructions will result in death or serious injury.

 **DANGER****HAZARD OF ELECTRIC SHOCK, EXPLOSION, OR ARC FLASH**

Verify cable polarity at both the battery and the inverter. Positive (+) must be connected to positive (+). Negative (-) must be connected to negative (-).

Failure to follow these instructions will result in death or serious injury.

 **WARNING****HAZARD OF ELECTRIC SHOCK, EXPLOSION, ARC FLASH, AND FIRE**

All cable entry points must be sealed to meet and maintain the requirements for IP65 enclosure standards.

Failure to follow these instructions can result in death, serious injury, or equipment damage.

 WARNING**HAZARD OF ELECTRIC SHOCK AND FIRE**

- Before powering on equipment, verify that all wiring is in good condition and that wire is not undersized. Do not operate the inverter with damaged or substandard wiring.
- Do not operate the inverter if it has been damaged in any way.
- Use only the accessories that are recommended by the manufacturer.
- Do not alter, damage, or obscure the markings and nameplates on the device.

Failure to follow these instructions can result in death, serious injury, or equipment damage.

 WARNING**HAZARD OF ELECTRIC SHOCK AND FIRE**

Verify that only one neutral-to-protective earth (ground) bond exists in the system.

Failure to follow these instructions can result in death, serious injury, or equipment damage.

 WARNING**RISK OF ELECTRIC SHOCK AND EQUIPMENT DAMAGE**

- Keep inverter cables at least 30 mm away from any heat source. The use of inverter cables in a high temperature environment may cause aging and damage to the insulation layer.
- Similar cables should be tied together, and different types of cables should be arranged at least 30 mm apart. Avoid cable cross-over.
- Tighten the cables to the torque specifications in this manual.

Failure to follow these instructions can result in death, serious injury, or equipment damage.

 WARNING**POTENTIAL COMPROMISE OF SYSTEM AVAILABILITY, INTEGRITY, AND CONFIDENTIALITY**

Follow the cybersecurity best practices in this document to help prevent unauthorized access to the system software.

Failure to follow these instructions can result in death, serious injury, or equipment damage.

⚠ WARNING

HEAVY EQUIPMENT

- The inverter weighs approximately 18 kg.
- To prevent personal injury, always use proper lifting techniques during installation, and follow local work safety rules.
- For structural and seismic stability, the Schneider Inverter must be mounted onto a vertical supporting surface strong enough to support the Schneider Inverter and all other equipment that is installed on the same surface.

Failure to follow these instructions can result in death, serious injury, or equipment damage.

⚠ ⚠ WARNING

RISK OF PERSONAL INJURY, EQUIPMENT DAMAGE, OR FIRE

- Always install the inverter on a wall that can support the weight of the inverter and bracket.
- Always install the bracket on a wall that spans the width of the bracket.
- Install the inverter and bracket on a brick or concrete wall. If that is not possible, a wall that meets the load bearing requirements of the inverter.
- Use the plastic expanding screws on wooden walls only. Wood must be flame retardant. Do not install the inverter on a flammable surface.

Failure to follow these instructions can result in death, serious injury, or equipment damage.

⚠ CAUTION

RISK OF PERSONAL INJURY OR EQUIPMENT DAMAGE

- Do not install the inverter in a location where the inverter will operate outside of the specified operating temperature range.
- Install the inverter in a location where the ambient temperature is between -25 to +60°C.
- Do not install the inverter near heat sources such as steam exhausts from boilers and dryers, or engine compartments. Do not install in a location that is exposed to direct sunlight. A shaded location is recommended.
- Avoid installing the inverter in a dusty environment.
- Install in a well ventilated environment.
- Always install the inverter in a location that minimizes the risk of water damage. Do not install the inverter in a location that is prone to flooding, or near water sprinklers or high pressure water jets.
- Do not expose this unit to excessive shock or vibration.
- Do not install the inverter at an altitude greater than 4000 meters above mean sea level.
- Install the inverter on a vertical surface, where the slope of the wall is within $\pm 5^\circ$.
- Do not install near a TV antenna or antenna cable.
- Install at a height of more than 1 meter above the floor or ground.

Failure to follow these instructions can result in injury or equipment damage.

Note: If installed outdoors, a shade is recommended above the inverter.

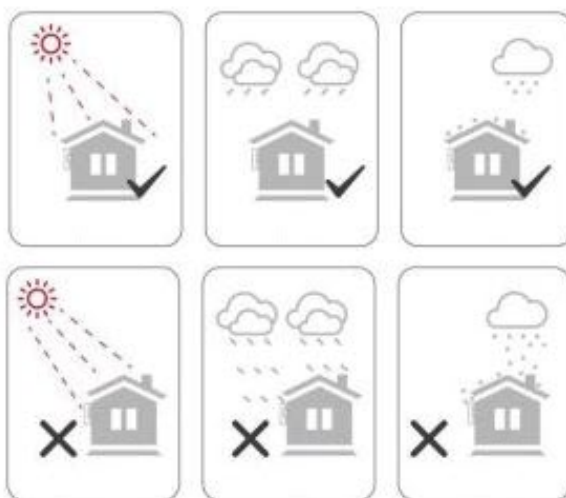

⚠ CAUTION

HOT SURFACE

Never touch the enclosure of an operating inverter.

Failure to follow these instructions can result in injury.

NOTICE

EQUIPMENT DAMAGE

To protect the inverter and other devices in the event of a surge from the PV components, it is recommended that you install a Surge Protection Device (SPD) device as part of your installation. For more information, see "Related Products" on page 24.

Failure to follow these instructions can result in equipment damage.

Limitations on Use

⚠ WARNING

HAZARD DUE TO UNINTENDED USE

The inverter is not intended for use in connection with life support systems or other medical equipment or devices. The inverter can only be used in grid-interconnected, and integrated PV systems. It is not suitable for any other application areas.

Failure to follow these instructions can result in death, serious injury, or equipment damage.

Explosive Gas Precautions

⚠ WARNING

IGNITION AND FIRE HAZARD

This equipment is not ignition protected. To prevent fire or explosion, do not install this product in locations that require ignition-protected equipment. This includes any confined space containing lead acid batteries, or flammable chemicals such as, natural gas (NG), liquid petroleum gas (LPG) or gasoline (Benzine/Petrol).

- Do not install in a confined space with machinery powered by flammable chemicals, or storage tanks, fittings, or other connections between components of fuel or flammable chemical systems.
- Do not install the inverter on a flammable surface. If local codes permit installation on a wood surface, ensure that the wood is flame retardant.
- Do not install the inverter near readily flammable materials such as cloth, paper, straw, or plastic sheeting. Keep flammable materials a minimum distance of 60 cm from the top surface and 30 cm from either side surface and the front of the inverter.

Failure to follow these instructions can result in death, serious injury, or equipment damage.

1 Overview

What's in This Chapter?

Overview	21
System Connection Diagram	21
What's in the Box	22
Physical Features	23
Dimensions	23
Related Products	24
Required Accessory	25
Required Power Meter	25
Related Installer Web Portal	25
Required Installer App	25
Related Home Owner App	26
Cybersecurity Guidelines	27

Overview

The Schneider Inverter (HY5K1EU1, HY6K1EU1, HY8K1EU1) is a single-phase high-performance inverter for residential battery-based off-grid and grid-tied applications. It is a self-contained DC to AC inverter and battery charger. It is compatible with Schneider Boost and solar applications. The inverter can be monitored using the Schneider Electric Installer Portal (qualified personnel) and Wiser Home app (home owner).

System Connection Diagram

Figure 1 System connection diagram (Spain)

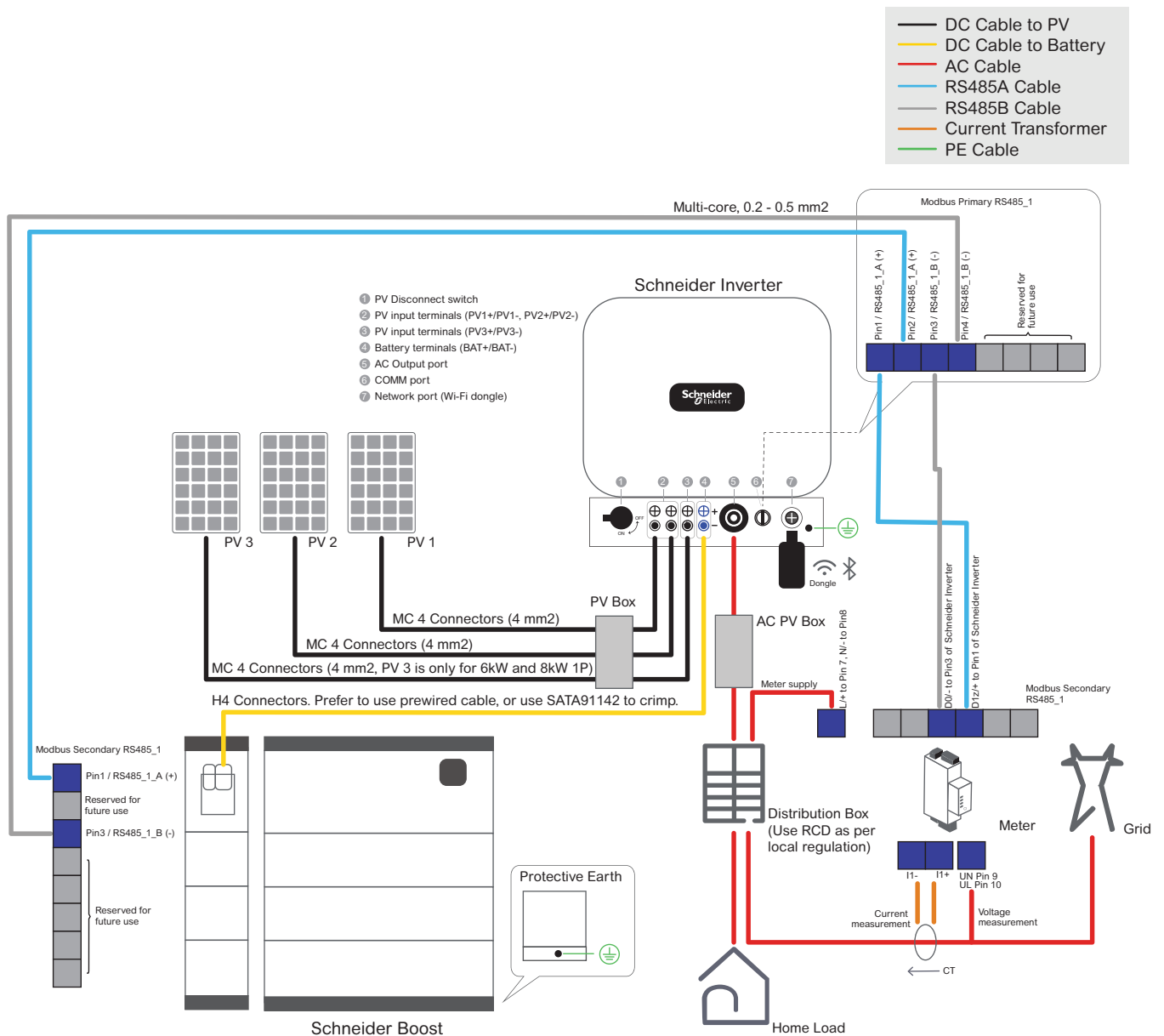

What's in the Box

IMPORTANT: Inspect the package for damage. If damage is found, contact Schneider Electric customer service.

Figure 2 Package contents

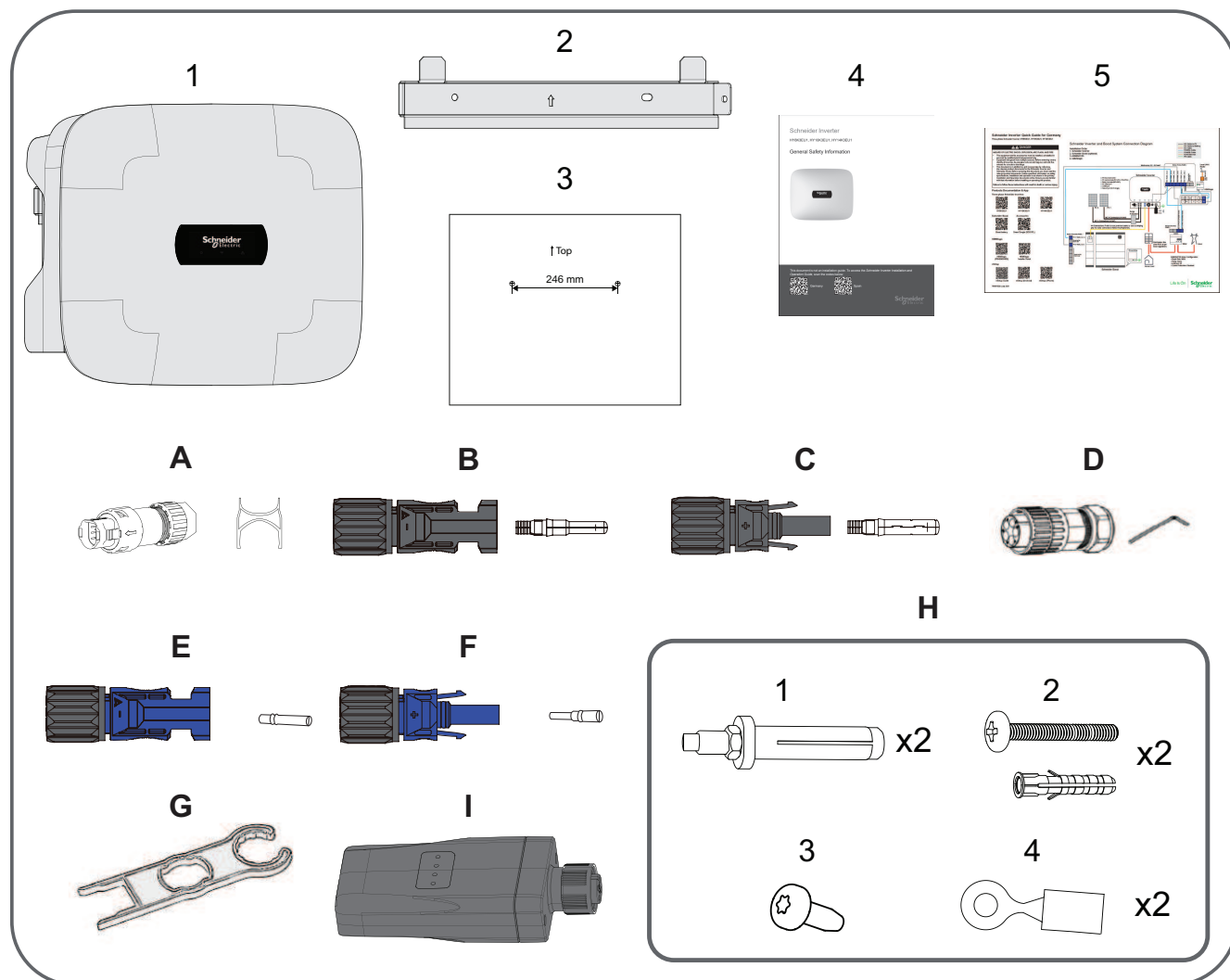

1	Schneider Inverter (1)	E	H4 battery connector (F) (1)
2	Mounting bracket (1)	F	H4 battery connector (M) (1)
3	Mounting template (1)	G	PV wrench (1)
4	Safety Guide (1)	H1	M6 metal expansion screw (2)
5	Quickstart Guide (1)	H2	M6 plastic expansion screw (2)
A	Comm. connector with wrench (1)	H3	M4x10 screw (1)
B	MC4 PV connector (F) (HY5K1EU1: 3; HY6K1EU1 & HY8K1EU1: 4)	H4	Crimping terminals (2)
C	MC4 PV connector (M) (HY5K1EU1: 3; HY6K1EU1 & HY8K1EU1: 4)	I	Wireless LAN Smart Dongle (SDG11TL) (1)
D	AC connector (1)		

Physical Features

Figure 3 Physical features

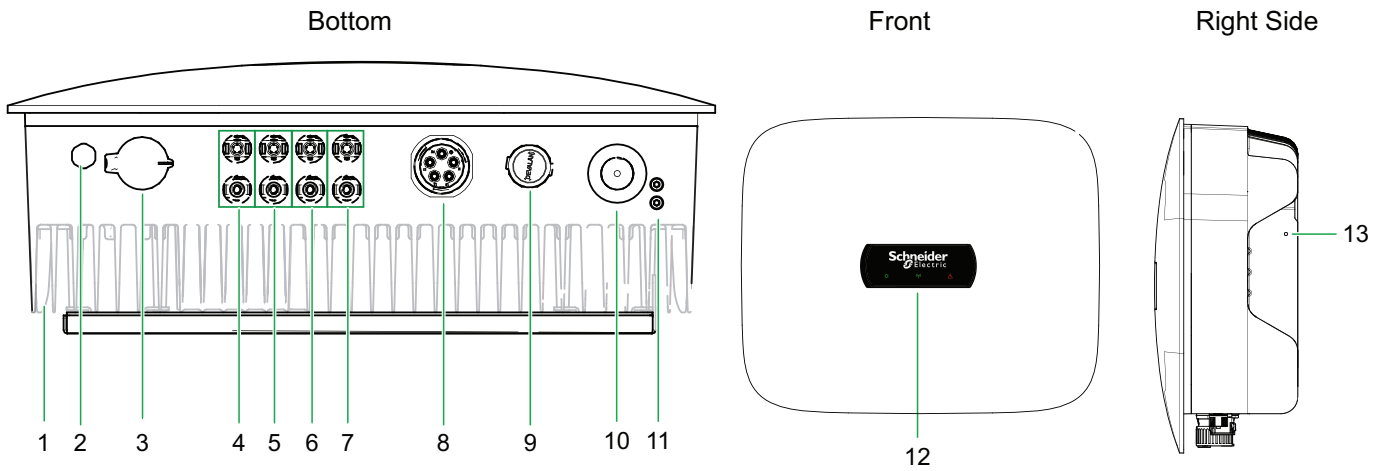

1	Heatsink	8	AC output port
2	Vent valve	9	Communication interface (COM)
3	PV disconnect switch	10	Network port for Wi-Fi dongle
4	PV input terminal (PV1+/PV1-)	11	Earthing (PE) terminal
5	PV input terminals (PV2+/PV2-)	12	Front LED panel
6	PV input terminals (PV3+/PV3-)	13	Screw hole for mounting bracket
7	Battery terminals (BAT+/BAT-)		

Dimensions

Figure 4 Inverter dimensions

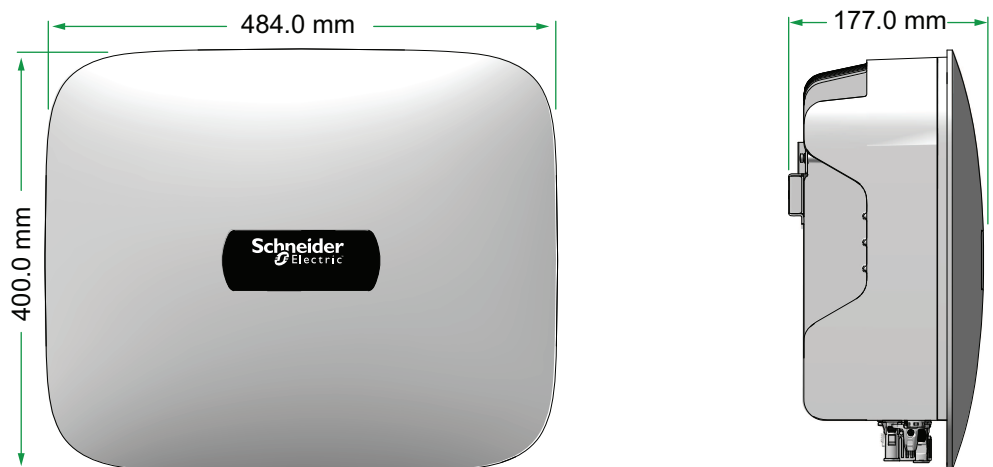

Related Products

Some installations may require additional devices for safety and monitoring. The following table provides recommended related products.

Table 1 One Phase specifications for Spain

Model	Power	Phase System	Continuous AC Current
HY5K1EU1	4600 W	1P+N	23 A
HY6K1EU1	6000 W	1P+N	30 A
HY8K1EU1	8000 W	1P+N	37 A

Table 2 AC Protection device requirements for Spain

			PV AC Box			MCB	
Model	PV AC Box SKU	Minimum cable cross-section	RCCB		SPD	MCB	
HY5K1EU1	R9KPVAC15	6 mm ²	40A - 30mA - F Si type	R9R71240	R9L12610	1P+N - C32	R9F12632
HY6K1EU1	R9KPVAC16	10 mm ²	40A - 30mA - F Si type	R9R71240	R9L12610	1P+N - C40	R9F12640
HY8K1EU1	R9KPVAC18	10 mm ²	63A - 30mA - A Si Type	A9R61263	R9L12610	1P+N - C50	A9K24650

Table 3 PV DC Box protection device requirements for Spain

Model	PV DC Box SKU	Quantity	MCB	Over-current Protection	Quantity	SPD	Quantity
HY5K1EU1	R9KPVDC2S800	1	C60 PV DC - 2P - 800V - A9N61652		2	A9L40271	2
HY6K1EU1	R9KPVDC1S800	1	C60 PV DC - 2P - 800V - A9N61652		3	A9L40271	3
	R9KPVDC2S800	1					
HY8K1EU1	R9KPVDC1S800	1	C60 PV DC - 2P - 800V - A9N61652		3	A9L40271	3
	R9KPVDC2S800	1					

Required Accessory

Wireless LAN Smart Dongle (SDG1ITL)

Required Power Meter

PowerTag Resi9 80 A (R9M80X6M) (Spain)

For grid-tied solar and battery systems with no Backup Controller, a power meter is required. Install and use a power meter to monitor the import, export, and consumption of power in your system. The Schneider Electric PowerTag Resi9 80 A (R9M80X6M) energy sensor must be wired into the system for this purpose. Connect this meter into the Modbus network.

To install with the Schneider Inverter system, see "Installing the PowerTag Resi9 80 A (R9M80X6M) (PTE6) Meter (Spain)" on page 57.

For more information, see the Energy sensor, PowerTag Resi9 80A 6 circuits LN Modbus R9M80X6M Installation Instructions.

Related Installer Web Portal

To access the Installer Portal, go to <https://installerportal.se.com>.

For more information, see Accessing Installer Portal on page 71.

Required Installer App

Wiser Home (Spain)

To complete commissioning, download the **Wiser Home** app:



Apple App Store



Google Play

Table 4 Software requirements

iOS™	Android™
iOS 12.0 or later	Android 5.0 or later

Wiser Device User Guide

For commissioning steps and instructions, see the [Wiser Device User Guide](#).

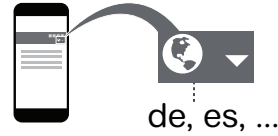

Scan the QR code for the Wiser Device User Guide and then select language.

Related Home Owner App

Wiser Home App (Spain)

Wiser Home is a mobile app that lets you add, configure, control and schedule your connected Schneider Electric devices from anywhere. Use the built-in energy monitoring feature to take action to reduce your utility bill.

For more information or to download the **Wiser Home** app, go to:



Apple App Store



Google Play

Cybersecurity Guidelines

This section includes information on how to help secure your system.

WARNING

POTENTIAL COMPROMISE OF SYSTEM AVAILABILITY, INTEGRITY, AND CONFIDENTIALITY

Follow the cybersecurity best practices in this document to help prevent unauthorized access to the system software.

Failure to follow these instructions can result in death, serious injury, or equipment damage.

To find out about the latest cybersecurity news, sign up for security notifications, or to report a vulnerability, visit the [Schneider Electric Cybersecurity Support Portal](#).

Recommended Actions

Note: The list of recommended actions below is not a complete list of possible cybersecurity measures. It is meant to be a starting point to improve the security of your system.

Passwords

- Passwords should include upper case, lower case, number, and special characters
- The password must have 10 characters minimum
- The password should not be easily found in the dictionary and a phrase is preferred
- Passwords should be changed frequently, at least once a year
- A default password must be changed immediately when first received and after a factory reset
- Never reuse passwords
- Never share passwords with unauthorized personnel

Network

- Schneider Electric devices should only be used in your personal home network
- Schneider Electric devices should not have a publicly accessible IP address
- Do NOT use port forwarding to access a Schneider Electric device from the public internet
- Schneider Electric devices should be on their own network segment. If your router supports a guest network or VLAN, it is preferable to locate the devices there
- Use the strongest Wi-Fi encryption available
- Use HTTPs in local network

Physical Site Security

To help prevent physical attacks:

- Install the system on private property, away from public passageways.
- Install the system in a location that is only accessible to the homeowner, or to people with the consent of the homeowner.
- Properly reinstall and close all covers.
- Route all cables through conduits.

2 Pre-Installation

What's in This Chapter?

Pre-Installation	31
Planning the Installation	31
Required Tools and Materials	31
Location	33
Mounting Surface Requirements	34
Clearance Requirements	35

Pre-Installation

Before installing the Inverter, read all instructions and cautionary markings in this manual. For a system diagram, see "System Connection Diagram" on page 21.

Note: Obtain all necessary permits prior to starting the installation. Installations must meet all local codes and standards. Installation of this equipment should only be performed by qualified personnel.

Planning the Installation

- Read this entire chapter before beginning the installation. It is important to plan the installation from beginning to end.
- Download Wiser Home and verify your account. See "Required Installer App" on page 25.
- Verify that you can successfully log in to the Installer Portal. See "Related Installer Web Portal" on page 25.
- Assemble all tools and materials needed for the installation.

Required Tools and Materials

The following materials and tools are not supplied but are required for installation.

Required for LOTO

- Appropriate PPE (e.g. safety glasses, gloves, protective footwear, etc.)
- Lock-out/Tag-out (LOTO) kit
- Calibrated professional digital multimeter (1000 V rated)

Required Tools and Materials

- Impact drill $\Phi 8$ mm
- Socket wrench
- M2 Phillips screwdriver
- Diagonal pliers
- Adjustable wrench
- Markers
- Rubber hammer
- Tool knife
- Wire cutters
- Cable ties
- Level

- Heat shrink tubing
- Heat guns
- Tape measure
- MC4 Crimping pliers (4 mm² - 6 mm²)
- SATA-91142 hydraulic pliers (4 mm² - 6 mm²)
- Torque wrench

Required Cables

Note: For cable specifications, see "Wiring Instructions" on page 42.

- Protective Earth (PE) cable
- AC power cables (450 Vac, 6 ~ 10 mm²)
- Battery cables (1000 Vdc, 4 mm²)
- PV power cables (1000 Vdc, 4 mm²)
- Communication cables (Shield-twisted pair (STP))
- Cable conduits and fittings per IEC 60364 requirements

Required for Mounting to Concrete or Brick Walls

- M6 stainless steel expansion bolts (if the length or number of provided bolts is insufficient)
- Appropriate drill bit and impact socket

Location

When selecting a location and installing the inverter, follow the guidelines below.

⚠ CAUTION
RISK OF PERSONAL INJURY OR EQUIPMENT DAMAGE
<ul style="list-style-type: none"> ▪ Do not install the inverter in a location where the inverter will operate outside of the specified operating temperature range. ▪ Install the inverter in a location where the ambient temperature is between -25 to +60°C. ▪ Do not install the inverter near heat sources such as steam exhausts from boilers and dryers, or engine compartments. Do not install in a location that is exposed to direct sunlight. A shaded location is recommended. ▪ Avoid installing the inverter in a dusty environment. ▪ Install in a well ventilated environment. ▪ Always install the inverter in a location that minimizes the risk of water damage. Do not install the inverter in a location that is prone to flooding, or near water sprinklers or high pressure water jets. ▪ Do not expose this unit to excessive shock or vibration. ▪ Do not install the inverter at an altitude greater than 4000 meters above mean sea level. ▪ Install the inverter on a vertical surface, where the slope of the wall is within $\pm 5^\circ$. ▪ Do not install near a TV antenna or antenna cable. ▪ Install at a height of more than 1 meter above the floor or ground.
Failure to follow these instructions can result in injury or equipment damage.

Note: If installed outdoors, a shade is recommended above the inverter.

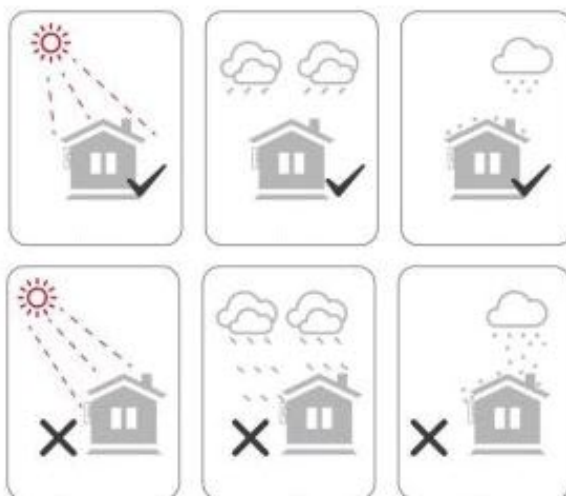

Mounting Surface Requirements

WARNING

HEAVY EQUIPMENT

- The inverter weighs approximately 18 kg.
- To prevent personal injury, always use proper lifting techniques during installation, and follow local work safety rules.
- For structural and seismic stability, the Schneider Inverter must be mounted onto a vertical supporting surface strong enough to support the Schneider Inverter and all other equipment that is installed on the same surface.

Failure to follow these instructions can result in death, serious injury, or equipment damage.

WARNING

RISK OF PERSONAL INJURY, EQUIPMENT DAMAGE, OR FIRE

- Always install the inverter on a wall that can support the weight of the inverter and bracket.
- Always install the bracket on a wall that spans the width of the bracket.
- Install the inverter and bracket on a brick or concrete wall. If that is not possible, a wall that meets the load bearing requirements of the inverter.
- Use the plastic expanding screws on wooden walls only. Wood must be flame retardant. Do not install the inverter on a flammable surface.

Failure to follow these instructions can result in death, serious injury, or equipment damage.

Clearance Requirements

Ensure that there is 30 cm of clearance on all sides and in front of the inverter. Install the inverter and battery with a minimum distance of 30 cm, and a maximum distance of 10 m.

Figure 5 Clearance requirements

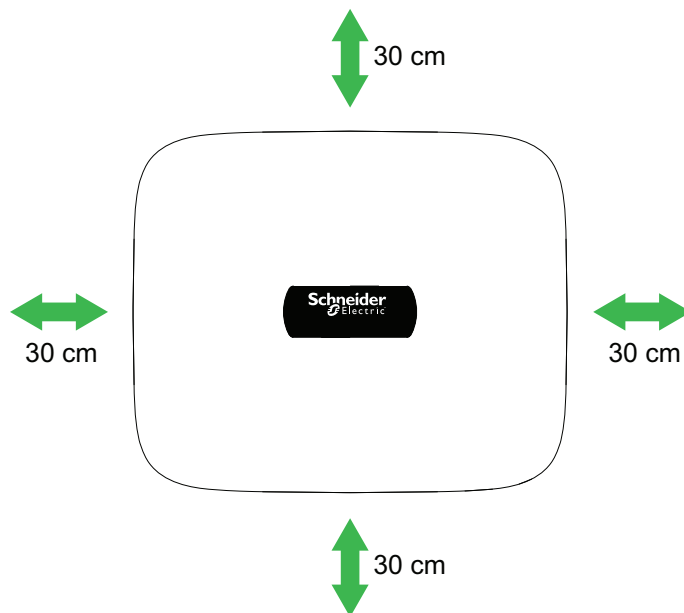

Table 5 Clearance requirements

Location	Minimum clearance
Left	30 cm
Right	30 cm
Top	30 cm
Bottom	30 cm
In front	30 cm

3 Installation

What's in This Chapter?

Installing the Inverter	37
Guidelines for Routing Cables	37
Lock-Out and Tag-Out (LOTO) Procedure	38
Installing the Mounting Bracket	40
Mounting the Inverter	41
Wiring Instructions	42
Protective Earth (PE) Ground Connection	42
PV Cable Connections	44
Battery Cable Connections	47
AC Cable Connections	49
Communication Cable Connections	53
Installing the PowerTag Resi9 80 A (R9M80X6M) (PTE6) Meter (Spain)	57
Connecting Your Device for Commissioning	60
Commissioning	61
Commissioning Checklist	62
Start-Up	63

Installing the Inverter

For a wiring diagram for your home energy management system, see "System Connection Diagram" on page 21.

- Complete "Lock-Out and Tag-Out (LOTO) Procedure" on the facing page before working.
- Follow all local codes and standards.

IMPORTANT: Connected backup loads must not exceed the inverter's power rating.

WARNING

HAZARD OF ELECTRIC SHOCK, EXPLOSION, ARC FLASH, AND FIRE

All cable entry points must be sealed to meet and maintain the requirements for IP65 enclosure standards.

Failure to follow these instructions can result in death, serious injury, or equipment damage.

Guidelines for Routing Cables

Follow these guidelines when routing the cables:

- Use enclosed conduits for routing any cables outside of the enclosure.
- Route the cables away from sharp edges that might damage the insulation. Avoid sharp bends in the cable—no less than a 4 in. (100 mm) radius.
- Allow for some slack in the cable tension.
- Keep the alignment of wire pairs inside the sheath as straight as possible.
- If possible, allow separation between communication and power cables.
- Use appropriate fasteners to avoid damage to the cable.

Lock-Out and Tag-Out (LOTO) Procedure

Before installing or uninstalling the inverter, de-energize, lock-out, and tag-out the inverter from all power sources.

⚠ ⚠ **DANGER**

HAZARD OF ELECTRIC SHOCK, EXPLOSION, ARC FLASH, AND FIRE

- This equipment must only be installed, configured, and serviced by qualified electrical personnel.
- Qualified electrical personnel must apply appropriate personal protective equipment (PPE), follow safe electrical work practices, and adhere to all applicable local and national electrical codes.
- Energized from multiple sources. Before working with cables, identify all sources, de-energize, lock-out, and tag-out and wait five minutes for circuits to discharge.
- Always use a properly rated voltage sensing device to confirm all circuits are de-energized.
- Before connecting power cables, make all other connections.

Failure to follow these instructions will result in death or serious injury.

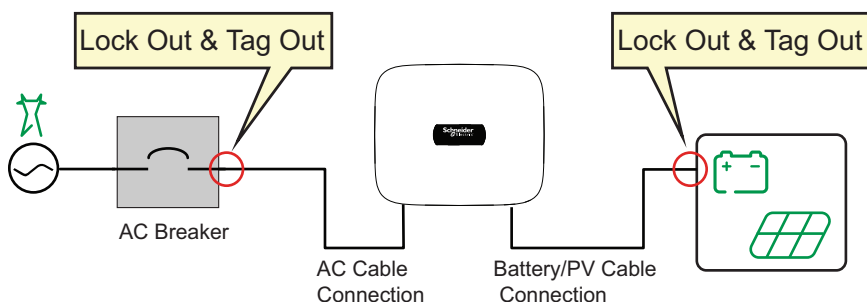

To lock-out and tag-out the Schneider Inverter:

1. Turn the inverter's PV Disconnect switch to the **OFF** position.
2. Identify and turn off the distribution breaker or switch between the Schneider Inverter and grid.
3. If a Schneider Boost is installed, rotate the manual DC disconnect switch to the **OFF** position. Lock out and tag out the Schneider Boost battery.
4. If installed, turn off, lock out and tag out the external PV disconnect device. If there is no external PV disconnect device, disconnect all incoming PV cables near the PV panels, following the PV panel manufacturer's procedures and instructions.
5. Verify that the main AC panel circuit breaker is turned off, locked out and tagged out.
6. Wait five minutes for the circuits to discharge.
7. Using a multimeter, verify that the Schneider Inverter is de-energized before

performing work. Measure voltage at the PV, battery and AC terminals on the inverter.

Installing the Mounting Bracket

Follow one of the procedures below, depending on the mounting surface:

- For concrete or brick walls on page 40.
- For wooden or plasterboard walls on page 41.

To install the mounting bracket on a concrete or brick wall:

1. Using the mounting template, mark the location of the two holes on the wall.

Figure 6 Mark the wall

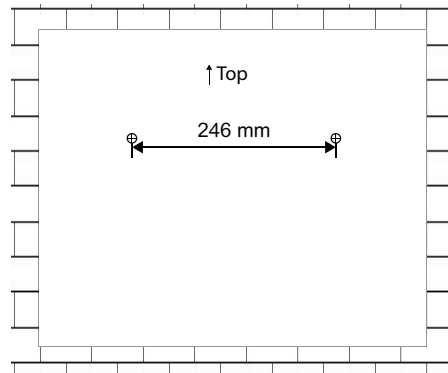

2. Use an electric drill to drill holes with a diameter of 8 mm and a depth of 45~50 mm in the wall. Clean the debris out of the holes.
3. Use a rubber hammer to knock the expansion bolt into each hole until the head washer of the expansion bolt is flush with the wall. If the length or number of supplied expansion bolts does not meet the installation needs, obtain your own M6 stainless steel expansion bolts.
4. After tightening the nut clockwise, use a wrench to twist the nut for 3~5 turns to tighten the expansion bolt into the wall.
5. Unscrew the nut, metal spring and plate washer counterclockwise, leaving the bolts and expansion tube fixed to the wall.

Figure 7 Install expansion bolts

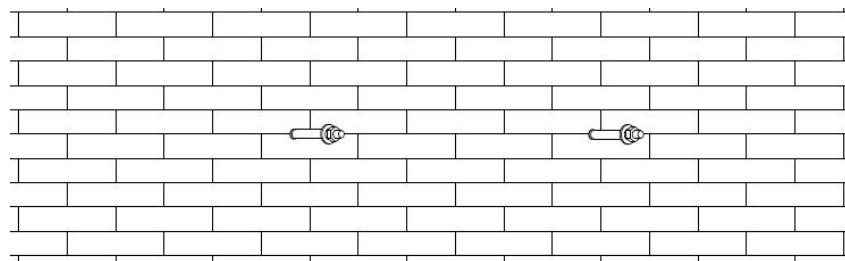

6. Place the mounting bracket over the expansion bolts until it is flush with the wall.
7. Install the washer onto the expansion bolt.
8. Screw the nut on clockwise, and then tighten it with a torque wrench. Torque to 5 Nm.

To install the mounting bracket on a wooden or plasterboard wall:

1. Hold the mounting bracket on the wall and then mark the location of the two holes on the wall.
2. Use an electric drill to drill holes with a diameter of 8 mm and a depth of 50~55 mm in the wall. Clean the debris out of the holes.
3. Hammer the plastic sleeves into the holes with a rubber hammer so that the outer edges of the sleeves are flush with the wall surface.
4. Attach the bracket to the sleeves using M6x50 cross-slot self-tapping screws. Ensure that the end of the screws are flush with the bracket.

IMPORTANT: Expansion screws should avoid penetrating through the fire-resistant layer.

The torque required will differ depending on the wall surface. Make sure that the screw is flush with the bracket.

Mounting the Inverter

To mount the inverter:

1. Hang the inverter on the mounting bracket.
2. Install the supplied M4x10 screw to connect the mounting bracket to the right side of the inverter. Torque to 1.5 Nm.

Figure 8 Connect mounting bracket and inverter

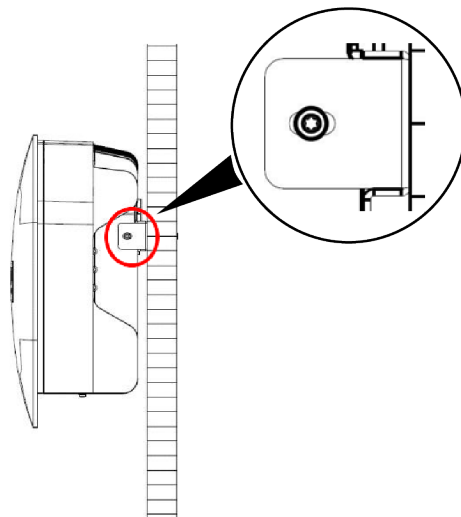

Wiring Instructions

This section includes instructions for connecting PE (ground), AC (Grid), Battery, PV, and Communication cables to the inverter.

WARNING

RISK OF ELECTRIC SHOCK AND EQUIPMENT DAMAGE

- Keep inverter cables at least 30 mm away from any heat source. The use of inverter cables in a high temperature environment may cause aging and damage to the insulation layer.
- Similar cables should be tied together, and different types of cables should be arranged at least 30 mm apart. Avoid cable cross-over.
- Tighten the cables to the torque specifications in this manual.

Failure to follow these instructions can result in death, serious injury, or equipment damage.

Note: Avoid installing cables where there is direct sunlight, rain or snow.

Protective Earth (PE) Ground Connection

DANGER

UNEARTHED (UNGROUND) EQUIPMENT

- Equipment earth (ground) terminals must be reliably connected to earth (ground) by appropriately sized protective earth (PE) conductors. All installations must comply with national and local codes. Consult national and local codes for specific earthing (grounding) and bonding requirements.
- When installing this equipment, install a protective earth (PE) wire first. When removing this equipment, the protective earth wire must be removed last.
- Verify that there is no damage to the earthing (grounding) conductor.
- Do not operate the device without an earthing (grounding) conductor installed.
- The device should be permanently connected to protective earth ground, and the protected area. Before operating this equipment, check the electrical earth connection to verify that the equipment is reliably earthed.

Failure to follow these instructions will result in death or serious injury.

Install the supplied earthing hardware:

1. Crimp the supplied O-terminal to the earthing wire. It is recommended to use 6 mm² wire for the earthing wire.
2. Install the earthing terminal of the crimped wire to the earthing terminal of the inverter using a Phillips screwdriver, as shown below. Torque to 1.5 Nm.

Figure 9 Earth connection

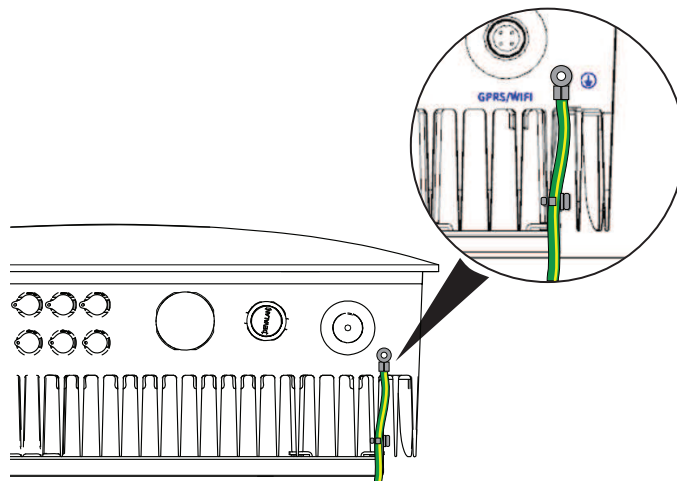

3. In order to help improve the corrosion resistance of the terminal, it is recommended to apply heat shrink tubing to the earthing terminal after the earthing cable assembly is completed.

PV Cable Connections

About the PV Array

Choose high-reliability, high-quality PV modules. The connected PV array modules should have an open-circuit voltage of less than 500 V at the lowest historical regional temperature, and the operating voltage should be within the MPPT voltage range.

WARNING

HAZARD OF ELECTRIC SHOCK, ARC FLASH, AND FIRE

- Observe electrical safety rules and PV panel manufacturer's safety information when connecting to PV modules, as they have a high voltage.
- Do not earth the positive or negative PV terminals.

Failure to follow these instructions can result in death, serious injury, or equipment damage.

NOTICE

EQUIPMENT DAMAGE

To protect the inverter and other devices in the event of a surge from the PV components, it is recommended that you install a Surge Protection Device (SPD) device as part of your installation. For more information, see "Related Products" on page 24.

Failure to follow these instructions can result in equipment damage.

Note: All PV modules in the same MPPT channel must be of the same type, have the same output and specifications, and have the same tilt angle. In order to reduce PV cable length and PV losses, we recommend installing the inverter as close as possible to the PV modules.

Table 6 PV cable specifications

Description	Specification
Cable size wire	4 mm ²
Cable outer diameter	4~7 mm
Cable strip length	8~10 mm

The supplied PV connector accessories are shown below:

**MC4 PV
Connector
(Male)**

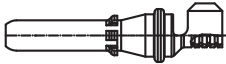
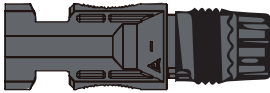

**MC4 PV
Connector
(Female)**

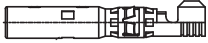
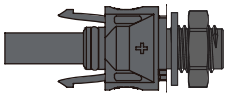

Connector plug

waterproof nut

latch terminal

Connecting PV Cables

To connect PV cables to the inverter:

1 Strip wires

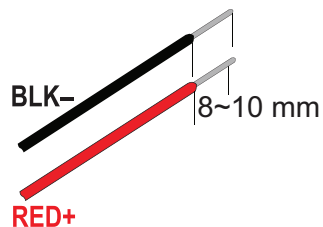

2 Separate connectors

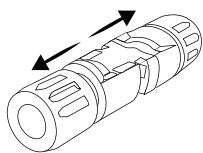

3 Remove cable glands and matching pins

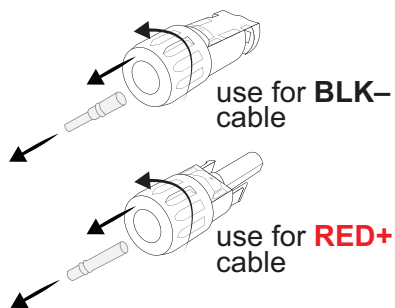

4 Crimp

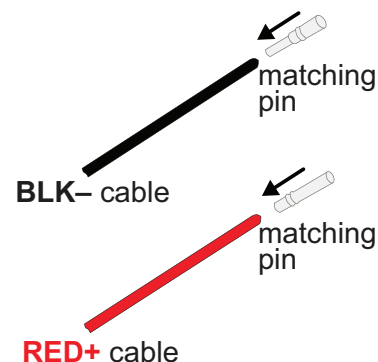

5 Thread cable through glands

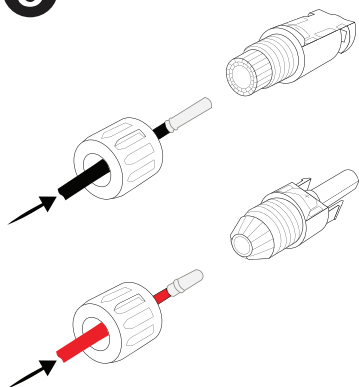

6 Insert contact into insulator

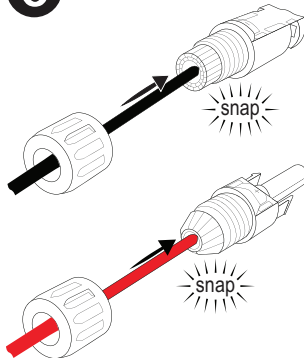

7 Attach cable glands

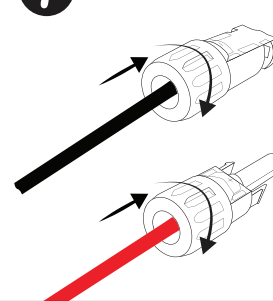

NOTE: Use PV wrench tool to tighten the cable glands to the insulator.

8 Verify that all batteries and inverters are OFF, and follow the LOTO procedure in this document.

OFF



wait 5 mins

9 Attach PV (-) connectors to (-) terminals and (+) connectors to (+) terminals

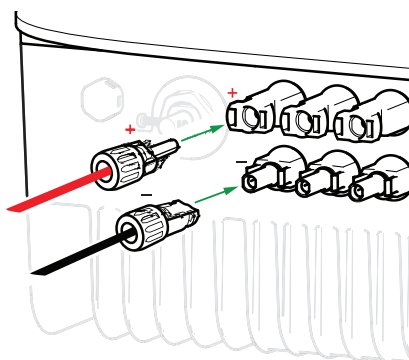

Battery Cable Connections

A set of pre-crimped positive (red) and negative (black) power cables is included in the package for the Schneider Boost battery controller (BATPMEU2).

If the supplied cables are not sufficient for your installation, use the specifications below to make your own cables.

Table 7 Battery cable specifications

Description	Specification
Cable size wire	4 mm ²
Cable outer diameter	4~7 mm
Cable strip length	8~10 mm
Maximum cable length	The connection between the battery and the inverter cannot exceed 10 m

The supplied battery connector accessories are shown below:

H4 Battery Connector (Male)

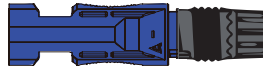

H4 Battery Connector (Female)

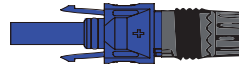

Connector plug

waterproof nut

latch terminal

See wiring instructions on the [next page](#).

Connecting Battery Cables

To connect battery cables to the inverter:

1 Strip wires

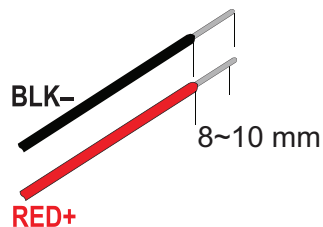

2 Separate connectors

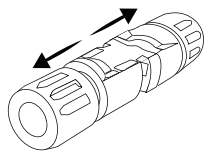

3 Remove cable glands and matching pins

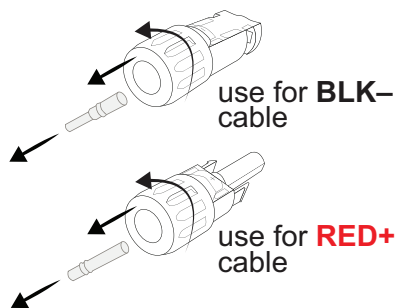

4 Crimp using SATA-91142 hydraulic pliers

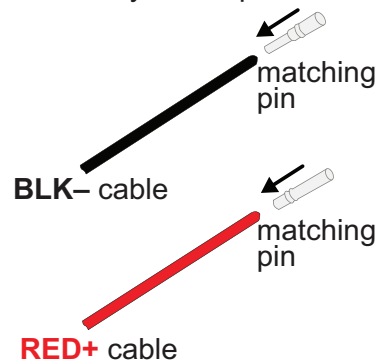

5 Thread cable through glands

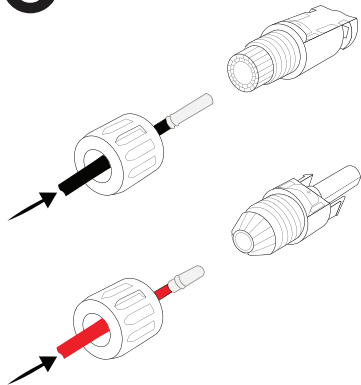

6 Insert contact into insulator

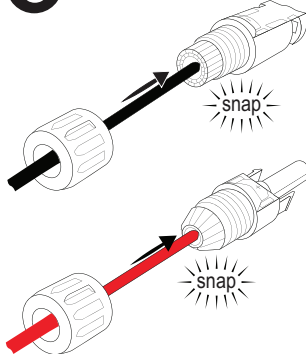

7 Attach cable glands

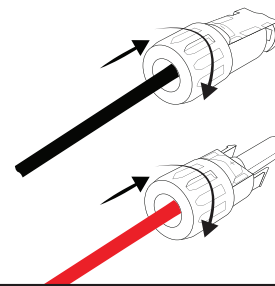

NOTE: Use PV wrench tool to tighten the cable glands to the insulator.

8 Verify that all batteries and inverters are OFF, and follow the LOTO procedure in this document.

OFF

wait 5 mins

9 Attach H4 (-) connectors to (-) terminals and (+) connectors to (+) terminals

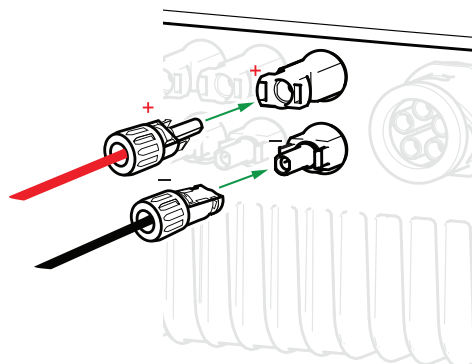

AC Cable Connections

Overview

Schneider Inverters can be used in single-phase power grids. They are suitable for grids with a one-phase voltage rating of 220 V/230V, and a frequency of 60 Hz/50 Hz.

Other technical requirements should meet the requirements of the local public power grid.

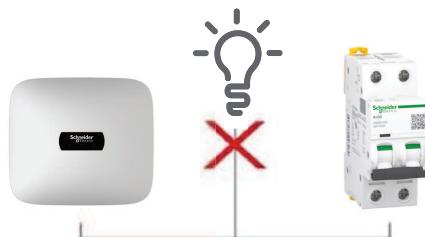

Note: Install a miniature circuit breaker between the inverter and the grid. No load can be directly connected to the inverter. The cross-sectional area of the external protective earthing conductor is the same as the cable specification size in Protective Earth (PE) Ground Connection on page 42.

Note: The Schneider Inverter HY5K1EU1, HY6K1EU1, and HY8K1EU1 are equipped with an integrated Residual Current Monitoring Unit, according to IEC 62109-2:2011. The Schneider Inverter limits the residual current from DC up to 6 mA. If the residual current exceeds 6 mA, the inverter shuts down.

Depending on installation protection, grid operator, local regulations, or national standards requirements, the installation of additional external RCDs may be required. In general, a Type A RCD with sensitivity of 300 mA or higher per inverter is recommended. For application in Spain, per Electrotechnical Regulations for Low Voltage (Reglamento Electrotécnico para Baja Tensión), it is mandatory for all residential installations to install a 30 mA minimum RCD.

Connect AC (Grid) Cables

To connect AC (Grid) cables:

1. Check the grid voltage and compare it with the permissible voltage range (refer to Specifications on page 86).
2. Follow "Lock-Out and Tag-Out (LOTO) Procedure" on page 38. Turn off all connected electrical connections and switches, and lock-out and tag-out the switches.
3. Open the supplied AC connector package. The AC connector accessories are as follows:

Figure 10 AC connector accessories

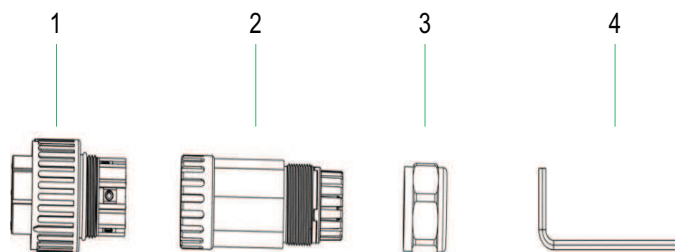

1	Wire end housing	3	Waterproof nut
2	Threaded housing	4	Hex wrench

4. Select 2 wires with an appropriate diameter (we recommend using copper wires with a cross-sectional area of 6~10 mm²), or choose a two-core wire with the same specifications as the sub-wire. Strip approximately 38-42 mm of the sheath and 8-10 mm of the conductor. The AC port connector is compatible with both rigid and flexible cable connections. Refer to the following table for cable specifications:

Table 8 AC cable specifications

Description	Specification		
	HY5K1EU1	HY6K1EU1	HY8K1EU1
The cross-sectional area of the copper wire	6 mm ²	10 mm ²	10 mm ²

Figure 11 Wire stripping specifications

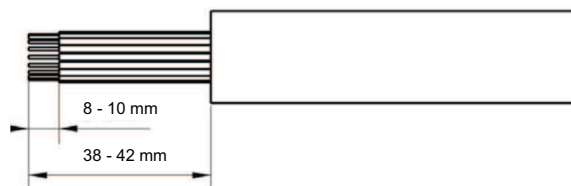

5. Remove the end housing of the connector from the threaded housing, unscrew the nut, and then thread the AC cable through each part, as shown in the figure below.

Figure 12 AC cable assembly

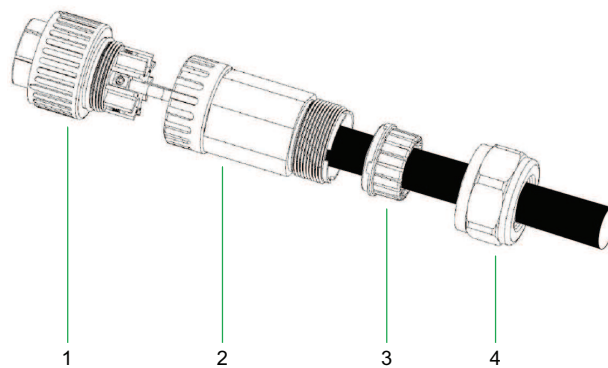

1	Wire end housing	3	Hole
2	Threading housing	4	Waterproof nut

6. Connect the L1, N, PE wires to the L1, N1, PE wiring holes in the connector.

Figure 13 AC connector pin definition

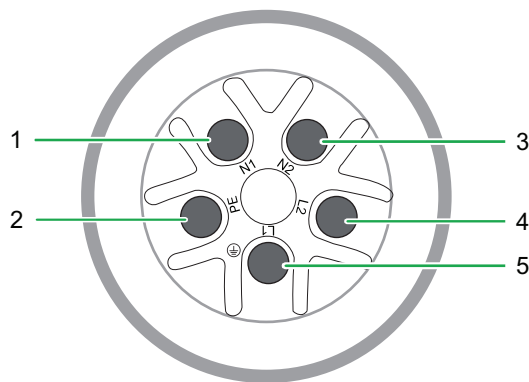

1	N1	4	L2 (not used)
2	PE	5	L1
3	N2 (not used)		

7. Tighten the screws with a hexagonal wrench. Torque to 1.0~1.5 Nm.

8. Tighten the threaded housing and waterproof nut. Torque to 3.5~4 Nm.

9. Remove the inverter's AC connector socket's dust cap, plug the AC connector into the connector socket, and then tighten the fastening nut on the connector wire end shell clockwise until it rotates into the socket limit card slot. Torque to 4~5 Nm.

Figure 14 AC inverter connection

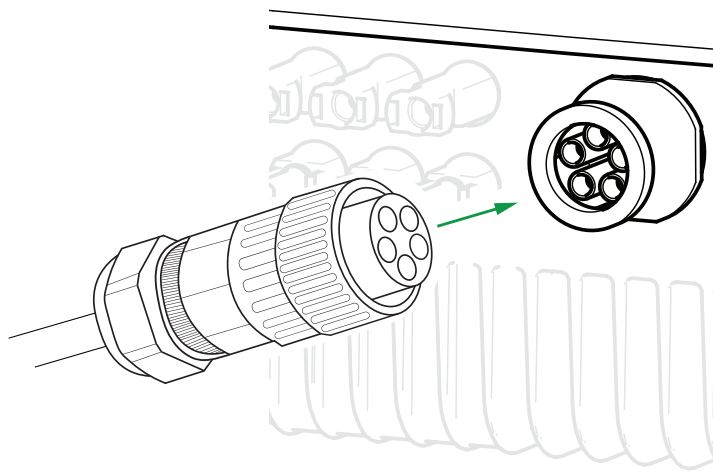

Communication Cable Connections

Communication Interface Signal Definition

Figure 15 Inverter, Boost and Energy Monitor communication wiring (Spain)

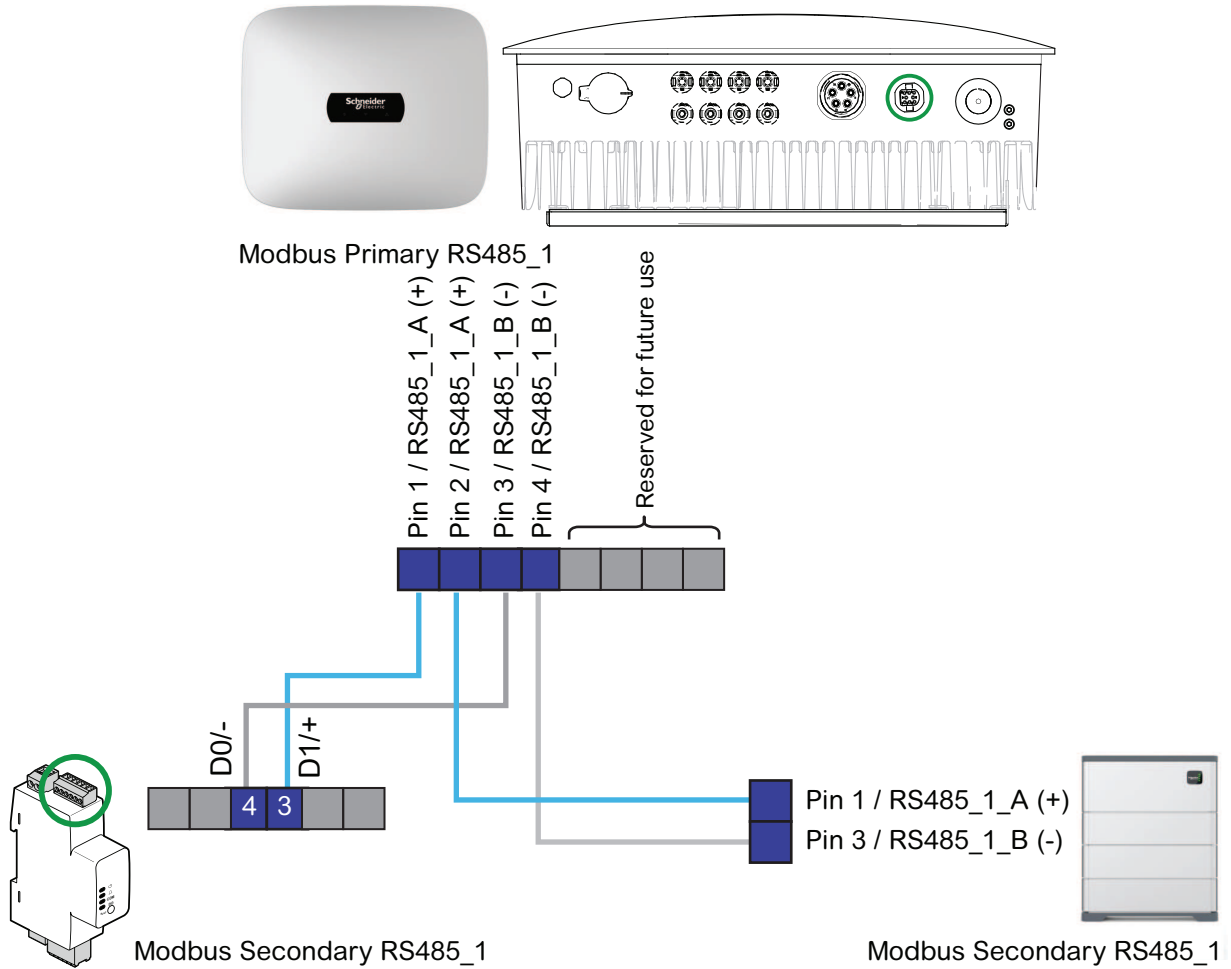

Note: Only Modbus Primary RS485_1 and Pins 1 to 4 are supported. Support for Modbus Secondary RS485_2 and Pins 5 to 8 is planned for a future release.

Figure 16 Communication cable pin definition

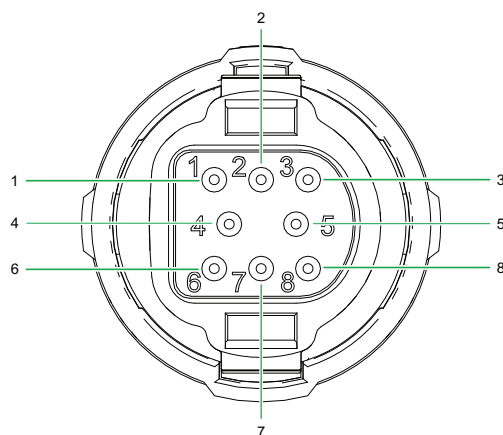

Pin	Definition	Function	Example
1	RS485_1_A	RS485A RS485 differential signal +	RS485 signal interface for communication with battery BMS/Meter
2	RS485_1_A	RS485A RS485 differential signal +	Pin 2 has the same function as Pin 1: RS485 signal interface for communication with battery BMS/Meter
3	RS485_1_B	RS485B RS485 differential signaling -	RS485 signal interface for communication with battery BMS/Meter
4	RS485_1_B	RS485B RS485 differential signaling -	Pin 4 has the same function as Pin 3: RS485 signal interface for communication with battery BMS/Meter
5	RS485_2_A	RS485A RS485 second differential signal +	RS485 signal interface for communication with Home Energy Management System or external controllers. Note: Reserved for future use.
6	RS485_2_B	RS485B RS485 second differential signaling -	RS485 signal interface for communication with Home Energy Management System or external controllers. Note: Reserved for future use.
7	CAN_L	CAN_L CAN communication low-bit data line	CAN bus for communication with battery BMS Note: Reserved for future use.
8	CAN_H	CAN_H CAN communication high-bit data line	CAN bus for communication with battery BMS Note: Reserved for future use.

Note: Support for Pins 5 to 8 is planned for a future release.

Connecting the Communication Cable

The communication connector accessories are shown below:

Figure 17 Communication connector accessories

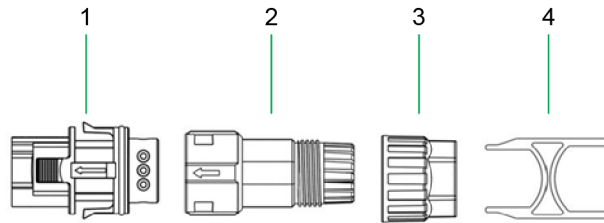

1	Wire end housing	3	Waterproof nut
2	Threaded housing	4	Removal wrench

To connect communication cables:

1. Select an appropriate cable that matches the specifications below:

Table 9 Communication cable specifications

Description	Specification
Wire core	Multi-core shield-twisted pair (STP)
Cross-sectional area	0.2~0.5 mm ²

2. Strip the wires 6~10 mm.

Figure 18 Communication wire strip length

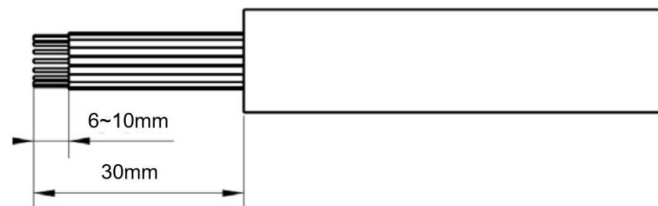

3. Unscrew the nut and pass the communication wires through the connector, as shown in the figure below.

Figure 19 Communication cable

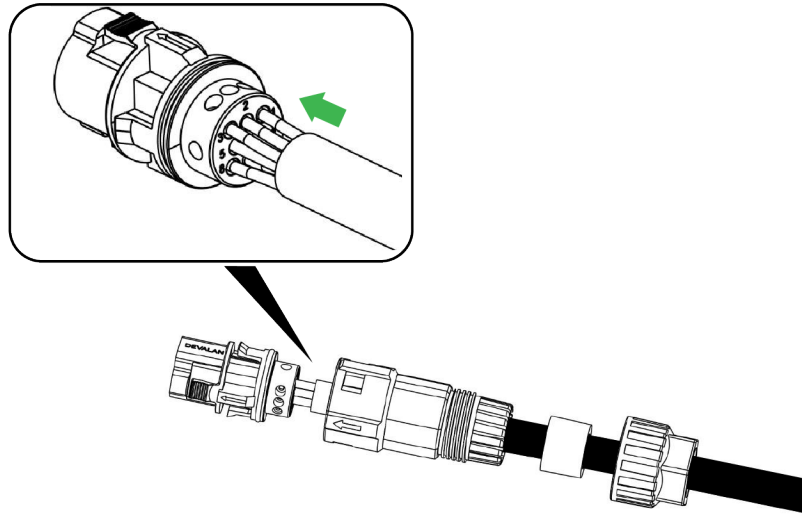

4. Connect the wires, following the pin definitions in "Communication Interface Signal Definition" on page 53. Tighten the screws. Torque to 0.2~0.4 Nm.
5. Connect the threaded housing to the wire end housing. When you hear a "click" sound, it means that the connection is complete.
6. Tighten the waterproof nut.
7. Remove the inverter's COM connector's socket dust cap, and then plug the connector into the connector socket, and complete the snap lock. When you hear a "click" sound, it means that the connection is complete.

Figure 20 Communication port

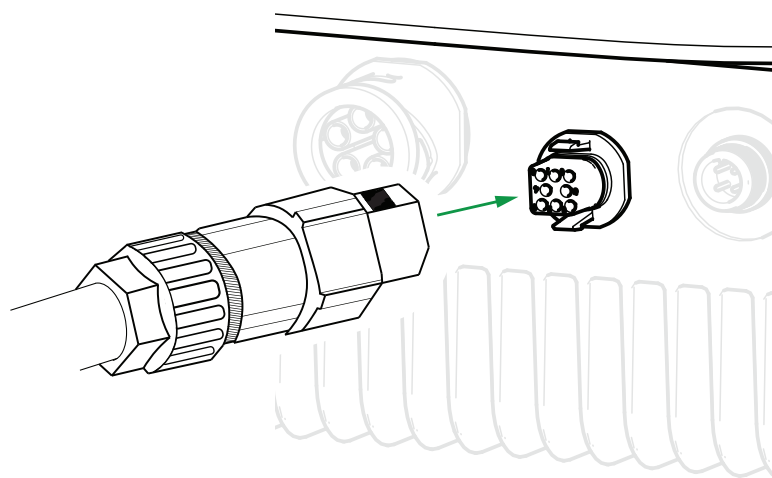

Installing the PowerTag Resi9 80 A (R9M80X6M) (PTE6) Meter (Spain)

If a battery is installed, you must install and use a power meter to monitor the import, export, and consumption of power in your system. If you do not have a battery installed, this is optional. The Schneider Electric PowerTag Resi9 80 A (R9M80X6M) series energy meter can be wired into the system for this purpose. The meter must be installed between the breaker panel and the grid. Connect this meter into the Modbus network, and configure the meter.

For more information, see the Energy sensor, PowerTag Resi9 80A 6 circuits LN Modbus R9M80X6M Installation Instructions.

To install the meter:

1. Before installing the meter, de-energize, lock-out, and tag-out the grid energy supply to the system. For more information, see "Lock-Out and Tag-Out (LOTO) Procedure" on page 38.
2. Mount the meter on the DIN rail of the distribution box. The meter clicks into place.

Figure 21 Mount the meter on the DIN rail

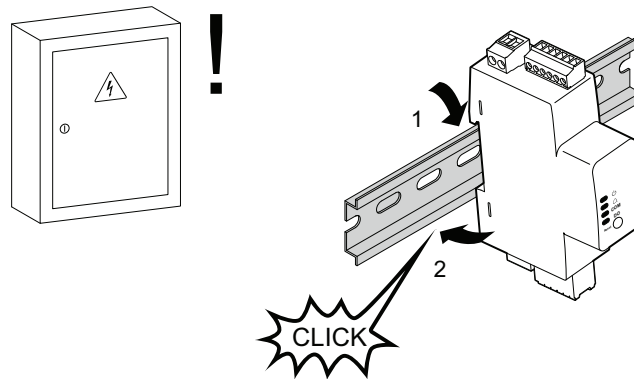

3. Pass the grid phase line through the current transformer of the meter.

Note: The blue and white wire outlet side of the meter is the load side.

Figure 22 Current transformer wiring

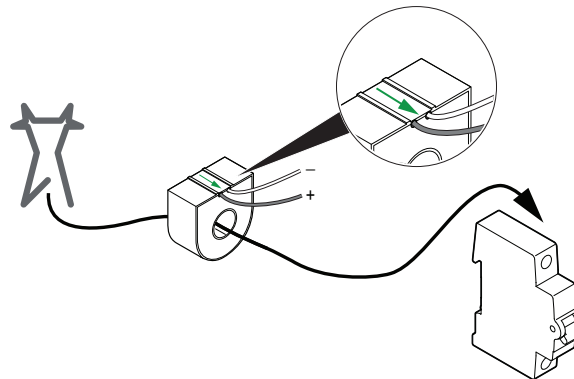

To connect the PTE6 to the Schneider Inverter:

Connect the eight wires to the meter according to the following table and diagram.

Table 10 PTE6 meter wiring

Category	PTE6 Pin Number	Meaning	Definition
Communication	3	485_A	Communications (RS485_A)
	4	485_B	Communications (RS485_B)
Power Supply	7	L/+	Phase input
	8	N/-	Neutral input
Voltage Sampling	9	UN	Voltage of neutral
	10	UL	Voltage of phase
Current Sampling	I1:1 Blue	I+	Current sampling inflow
	I1:1 White	I-	Current sampling outflow

Figure 23 PTE6 connection diagram

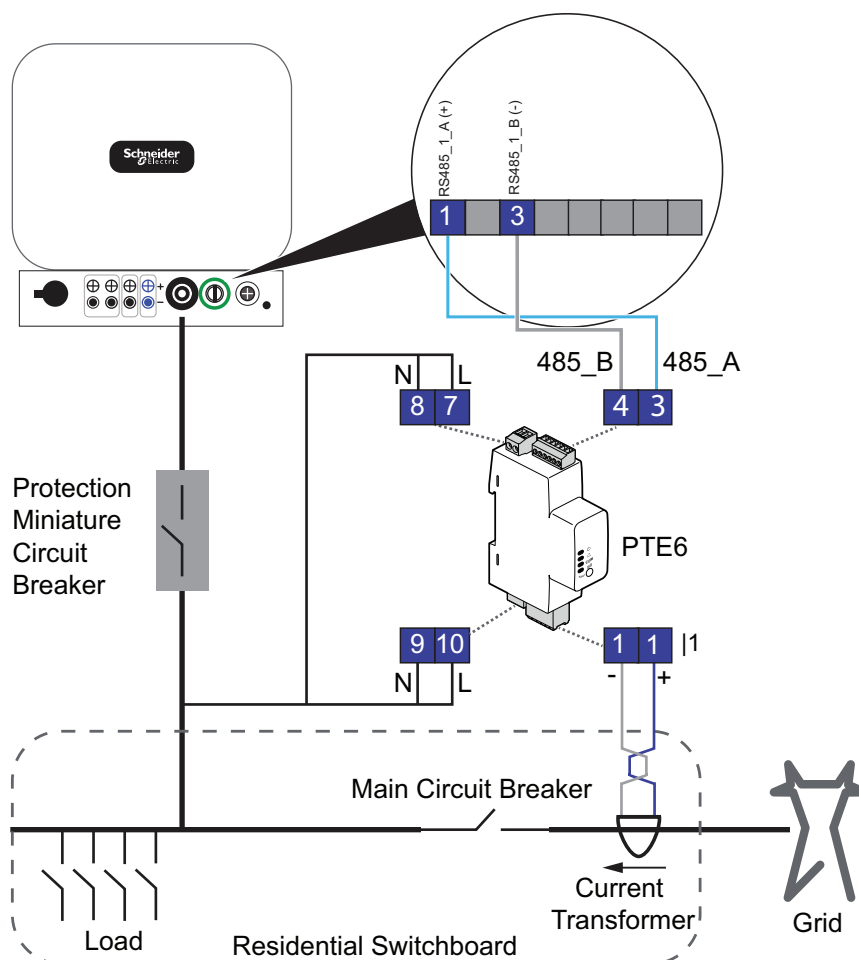

Configuring the PowerTag Resi9 80 A (R9M80X6M) Energy Sensor

If a PowerTag Resi9 80 A (R9M80X6M) energy sensor is installed, the following communications settings need to be configured for the inverter. After you have connected to the inverter using the commissioning app (following the steps Connecting Your Device for Commissioning on page 60), but before start up, complete these steps:

To configure the meter:

1. Press the **Reset** button 3 times. The Alarm LED will flash three times and then turns off. The COM LED turns off to confirm that the meter is in the default value change mode.
2. To exit the settings, press and hold the **Reset** button for more than two seconds, until the Alarm LED flashes. The COM LED lights in green.

Connecting Your Device for Commissioning

Connect the inverter to the commissioning app to complete the commissioning process.

The inverter connects to the commissioning app using a Bluetooth connection from the dongle. The dongle Bluetooth connection is automatically activated for 30 minutes after the inverter is powered on. If the Bluetooth connection times out, remove and then reconnect the dongle to the inverter.

To connect your device:

1. While the inverter is de-energized, connect the dongle to the network port.

Note: Refer to *Wireless LAN Smart Dongle Guide (TME34287)*.

2. Power on the inverter. See "Start-Up" on page 63.
3. Download and create an account on the **Wiser Home** app. See Required Installer App on page 25.
4. When the dongle LEDs are lit, you can connect your mobile device to the commissioning app using the dongle's Bluetooth hotspot.
5. Find the serial number of the inverter underneath the barcode on the label on the right side of the inverter.

Figure 24 Location of serial number on inverter



6. Use the app to configure and commission the inverter.

Commissioning

Note: The Schneider Inverter must be network connected to be commissioned. See "Connecting Your Device for Commissioning" on the previous page.

Commissioning with Wiser Home (Spain)

To complete commissioning, download the **Wiser Home** app:



Apple App Store



Google Play

For commissioning steps and instructions, see the [Wiser Device User Guide](#).



Scan the QR code for the Wiser Device User Guide and then select language.

Commissioning Checklist

DANGER

HAZARD OF ELECTRIC SHOCK, EXPLOSION, ARC FLASH, AND FIRE

Thoroughly inspect the inverter and battery (if using) prior to energizing. Verify that no tools or materials have been left inside or on top of the inverter and battery, and that all covers and doors are properly closed and secured.

Failure to follow these instructions will result in death or serious injury.



Before powering on the inverter, perform the following inspections:

- All clearances are correct.
- The inverter is mounted, stable, and fixed to an appropriate surface.
- The inverter and heatsink are free of debris, and there are no tools, extra screws, or other objects left on top of the inverter.
- The cables are routed through the provided connectors.
- All wires are properly and firmly connected.
- The Wi-Fi dongle is properly and firmly connected.
- The protective earth wire is properly and firmly connected.
- The cable polarity at the battery, PV panels, and the inverter are correct.
- The protection circuit breaker for the grid or PV is turned on.
- Unused terminals and connections are covered with waterproof covers.
- The product's safety labels and rating label are visible and affixed permanently to the unit.
- Check that you have a device with the latest operating system and a charged phone battery at the commissioning site.
- If you are viewing this document online, download a copy that you can access offline.
- Use the commissioning app to configure the inverter (and battery, if installed) and verify operation.

Start-Up

Perform the start-up procedure according to whether a Schneider Boost battery is installed in your system:

- For systems with both a Schneider Inverter and Schneider Boost, see "Start Up Procedure for Systems with Schneider Inverter and Schneider Boost" on the next page
- For systems with just a Schneider Inverter, see "Start Up Procedure for Systems with Schneider Inverter Only" below

WARNING

HAZARD OF ELECTRIC SHOCK, EXPLOSION, AND FIRE

Only power on the unit after the installation work is completed, and the commissioning checks in "Commissioning Checklist" on the previous page are complete.

Failure to follow these instructions can result in death, serious injury, or equipment damage.

Note: To troubleshoot during the start-up procedure, see "Troubleshooting steps" on page 65.

Start Up Procedure for Systems with Schneider Inverter Only

1. Ensure that the inverter is correctly mounted, the cables are the correct polarity, and that the dongle and all wire connections are properly connected.
2. Set the external AC and DC breaker switches to **ON**.
3. If the breaker trips, see "Condition 1" on page 65.
4. Rotate the DC Switch at the bottom of the inverter to the **ON** position.
5. Confirm that the inverter's power LED is lit in green. If it is not lit, see "Condition 3" on page 65.
6. Confirm that the LED on the dongle is lit. If it is not lit, see "Condition 4" on page 65.
7. Connect your device to the system. For more information, see "Connecting Your Device for Commissioning" on page 60.
8. In the commissioning app, confirm that PV data appears. If no PV data is observed, see "Condition 9" on page 66.
9. In the commissioning app, confirm that power meter data appears. If no power meter data is observed, see "Condition 5" on page 65.

Start Up Procedure for Systems with Schneider Inverter and Schneider Boost

1. Ensure that the inverter and battery are correctly mounted, the cables are the correct polarity, and that the dongle and all wire connections are properly connected.
2. Set the external AC and DC breaker switches to **ON**.
3. If the breaker trips, see "Condition 1" on the facing page.
4. On the Schneider Boost, rotate the manual DC disconnect switch to the **ON** position.
5. On the Schneider Boost, press and hold the "Black Start" button for 10 seconds until the battery's LED display starts flashing green. Release the button.
6. If the battery's LED does not light in green, or does not repeatedly light up in yellow from top to bottom, see "Condition 2" on the facing page.
7. Confirm that the inverter's power LED is lit in green. If it is not lit, see "Condition 3" on the facing page.
8. Confirm that the LED on the dongle is lit. If it is not lit, see "Condition 4" on the facing page.
9. Connect your device to the system. For more information, see "Connecting Your Device for Commissioning" on page 60.
10. In the commissioning app, confirm that power meter data appears. If no power meter data is observed, see "Condition 5" on the facing page.
11. In the commissioning app, confirm that battery data appears. If no battery data is observed, see "Condition 6" on page 66.
12. On the inverter, confirm that the Event LED is not lit. If it is lit, see "Condition 7" on page 66.
13. Rotate the DC Switch at the bottom of the inverter to the **ON** position.
14. On the inverter, confirm that the Event LED is not lit. If it's lit, see "Condition 8" on page 66.
15. In the commissioning app, confirm that PV data appears. If no PV data is observed, see "Condition 9" on page 66.

Start-Up Troubleshooting

Table 11 Troubleshooting steps

Condition Type	System Performance	Potential Cause	Troubleshooting Steps
Condition 1	The inverter's circuit breaker has tripped	A short circuit caused by a misconnection of the AC wires (L-PE)	<ol style="list-style-type: none"> 1. Turn off the AC protection breaker between the inverter and the grid. 2. Check the power cable and PE cable connections and polarity. Correct if needed. 3. Start the inverter using the start-up procedure on page 63. 4. If the event persists, contact Technical Support.
Condition 2	The battery's LED is not lit	The battery's voltage is too low to power up.	<ol style="list-style-type: none"> 1. Turn off the DC disconnect switch on the battery. 2. Remove the battery controller. 3. Use a multimeter to measure the voltage of the battery modules. 4. If the event persists, contact Technical Support.
	The battery's LED flashes yellow	Internal hardware event	<ol style="list-style-type: none"> 1. Turn off the DC disconnect switch on the battery. 2. Remove the battery controller. 3. Check that the connections on the top and bottom of the battery modules are intact one by one. Correct if needed. 4. Re-stack the battery modules. 5. Start the battery using the start-up procedure on page 63. 6. If the event persists, contact Technical Support.
Condition 3	The inverter's power LED is not lit	The power connection between the inverter and battery is not correct.	<ol style="list-style-type: none"> 1. Turn off the DC disconnect switch on the battery. 2. Check the connection and polarity of the DC cable between the inverter and battery. Correct if needed. 3. Start the battery using the start-up procedure on page 63. 4. If the event persists, contact Technical Support.
Condition 4	The dongle's LED is not lit	Poor connection between the inverter and dongle.	<ol style="list-style-type: none"> 1. Remove and reconnect the dongle. 2. If the event persists, contact Technical Support.
Condition 5	The commissioning app displays an "Undetected" status for the energy meter; and no grid data is observed in the commissioning app	Poor communication connection between the inverter and power meter.	<ol style="list-style-type: none"> 1. Turn off the AC protection breaker between the inverter and the grid. 2. Turn off the switch for the battery. 3. Check the communication cable connections between the inverter and battery. Correct if needed. 4. Start the inverter using the start-up procedure on page 63. 5. If the event persists, contact Technical Support.

Condition Type	System Performance	Potential Cause	Troubleshooting Steps
Condition 6	The commissioning app displays an "Undetected" status for the battery and no battery data is observed.	Poor communication connection between the inverter and battery.	<ol style="list-style-type: none"> 1. Turn off the AC protection breaker between the inverter and the grid. 2. Turn off the switch for the battery. 3. Check the communication cable connections between the inverter and battery. Correct if needed. 4. Start the inverter using the start-up procedure on page 63. 5. If the event persists, contact Technical Support.
Condition 7	The inverter's Event LED is lit and no grid current is observed in the commissioning app.	AC connection is not correct (L-N, N-PE)	<ol style="list-style-type: none"> 1. Turn off the AC protection breaker between the inverter and the grid. 2. Check the polarity of the AC cable between the inverter and the grid. Correct if needed. 3. Start the inverter using the start-up procedure on page 63. 4. If the event persists, contact Technical Support.
Condition 8	The inverter's Event LED is lit	External RCD nuisance trips (if RCD is installed)	<ol style="list-style-type: none"> 1. Turn off the AC protection breaker between the inverter and the grid. 2. Turn off the switch for the inverter. 3. Turn off the switch for the battery. 4. Check the status of the RCD or RCCB between the inverter and the grid. 5. If tripped, replace the RCD with an upgraded type. For example, if the current RCD is Type A, replace with Type A-SI. 6. Start the inverter using the start-up procedure on page 63. 7. If the RCD continues to trip, replace it with a 300 mA RCD or RCCB. 8. If the event persists, contact Technical Support.
		PV connection is not correct (String-PV)	<ol style="list-style-type: none"> 1. Turn off the AC protection breaker between the inverter and the grid. 2. Turn off the switch for the inverter. 3. Turn off the switch for the battery. 4. Check the PV cable connections between the solar string and the inverter. Correct if needed. 5. Start the inverter using the start-up procedure on page 63. 6. If the event persists, contact Technical Support.
Condition 9	No PV data is observed in the commissioning app.	The lighting conditions for each PV string is not sufficient.	<ol style="list-style-type: none"> 1. Check that the lighting conditions for the solar string are sufficient. 2. If the event persists, contact Technical Support.

4 Operation and Troubleshooting

What's in This Chapter?

Operating the Inverter	68
Zero Export Mode	68
Front Panel LED Indicators	68
Monitoring Operation with the Schneider Electric Installer Portal	70
Accessing Installer Portal	71
Selecting a language	71
Adding a Site	72
Configuring Export Mode	73
Viewing Events in the Installer Portal	74
Viewing Firmware Information	76
Troubleshooting	77
General Troubleshooting Steps	77
Contacting Technical Support (Spain)	77
Troubleshooting and Event List	78

Operating the Inverter

Zero Export Mode



By default, zero export mode is enabled. In zero export mode, the Schneider Inverter does not export any power to the grid.

Qualified personnel can configure the mode of operation in the Installer Portal. See "Configuring Export Mode" on page 73.



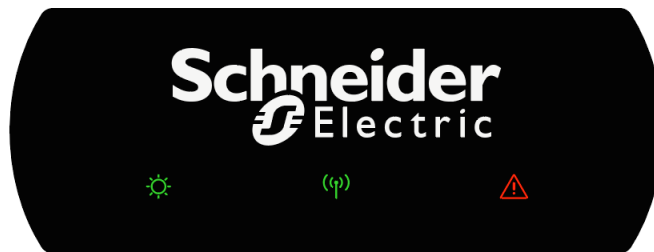

Front Panel LED Indicators

There are three LED indicators on the front panel, and the icons are shown below:



Icon	Meaning	Color
	Power	Green
	Communication	Green
	Event	Red

These LEDs can display the following states:

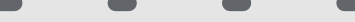
LED State	Indicator Pattern	Behavior
On		Continuously lit
Fast blink		0.2 seconds on, 0.2 seconds off
Blink		1 second on, 1 second off
Medium slow blink		1 second on, 2 seconds off
Slow blink		1 second on, 4 seconds off
Off		Continuously unlit

The status of the LED indicators is shown in the following tables:

Power LED

Color	State	Meaning	Explanation
Green	ON	Grid-connected operation	The inverter is operating in grid-tied mode
	Fast blink	Grid synchronization	The inverter is synchronizing with the grid
	Blink	Off-grid operation	The inverter is operating in off-grid mode
	Medium slow blink	Standby operation	The inverter is grid-tied and operating in standby mode
	Slow blink	Wait	The inverter is in wait mode
	OFF	Not running	The inverter is not running

Comm LED

Color	State	Meaning	Explanation
Green	Fast Blink	Firmware upgrade	The inverter is undergoing a firmware upgrade
	Medium slow blink	Wi-Fi or ECB (External Communication Bus) communication	The inverter is receiving Wi-Fi* or ECB data
	Slow blink	CAN communication	The inverter is receiving CAN data
	OFF	Not receiving communication data	The inverter is not receiving communication data

* Depending if the Wireless LAN Smart Dongle is installed.

Event LED

Color	State	Meaning	Explanation
Red	On	Arc event	The inverter has an arc event
	Fast blink	Earth (Ground) event	The inverter has a protective earth (ground) event
	Blink	Critical event	There is an important event
	Slow blink	Normal operation event	There is a operational event, but no action is required
	Off	Normal operation	There are no events

Monitoring Operation with the Schneider Electric Installer Portal

The Installer Portal provides remote monitoring capability for the inverter and other devices in the network. It is for use by qualified personnel.

Figure 25 Monitoring sites with the Installer Portal





Accessing Installer Portal

Note: The Installer Portal requires login credentials from MySchneider. Register for a MySchneider account at www.se.com/myschneider, then log in to the Installer Portal using your MySchneider credentials.

To access Installer Portal:

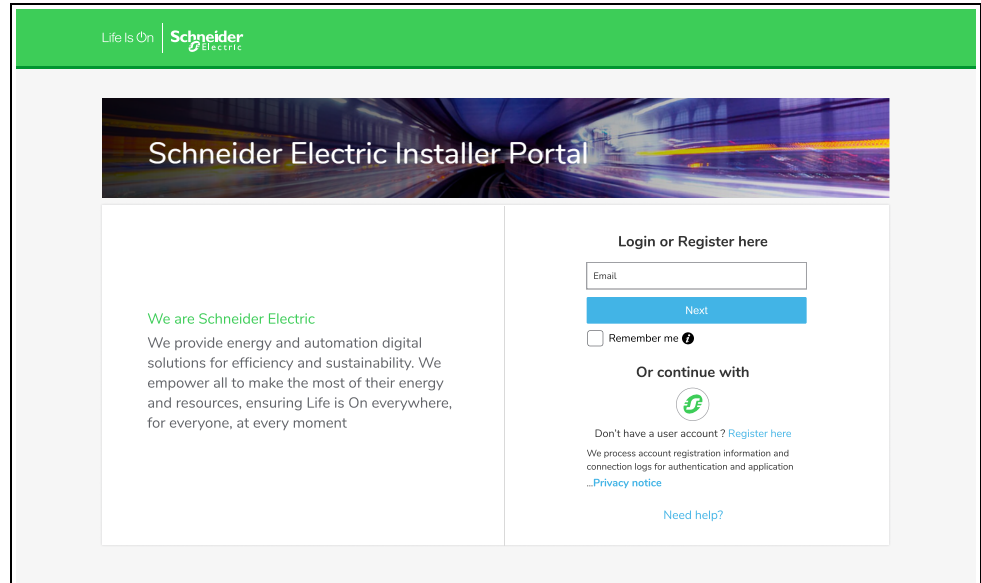
1. Go to <https://installerportal.se.com>.



2. Enter your credentials or select  for single sign-on.

IMPORTANT: Do not share your login credentials.

Selecting a language

After logging in, select a language from the menu in the top right.

Figure 26 Language menu

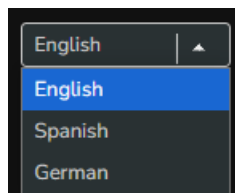

Adding a Site

Note: After installation, it is mandatory to register your site in the Installer Portal.

Once you have registered and logged into the Installer Portal, you can add your site(s). From the left menu, click **Add Site**, and enter the required information.

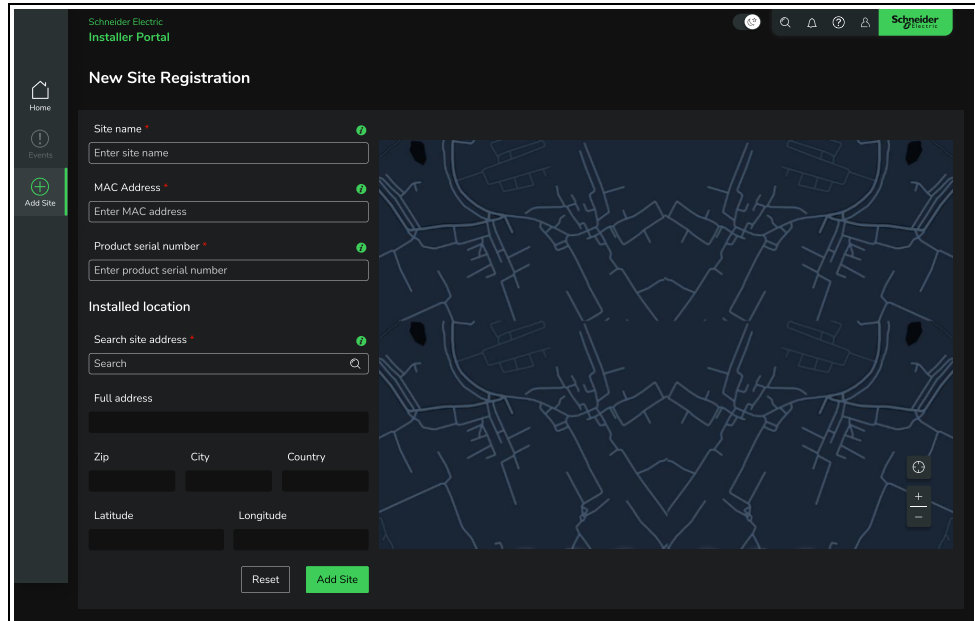

The screenshot shows the 'New Site Registration' form in the Schneider Electric Installer Portal. The form is set against a dark background with a map of a city street grid. On the left, there is a vertical navigation menu with icons for Home, Events, and Add Site (which is highlighted). The form fields are as follows:

- Site name ***: Input field with placeholder 'Enter site name' and a green question mark icon.
- MAC Address ***: Input field with placeholder 'Enter MAC address' and a green question mark icon.
- Product serial number ***: Input field with placeholder 'Enter product serial number' and a green question mark icon.
- Installed location**:
 - Search site address ***: Search input field with placeholder 'Search' and a magnifying glass icon.
 - Full address**: Input field.
 - Zip**, **City**, **Country**: Three separate input fields.
 - Latitude**, **Longitude**: Two separate input fields.

At the bottom of the form, there are two buttons: 'Reset' and 'Add Site' (in green).

Configuring Export Mode

By default, zero export mode is enabled. In zero export mode, the Schneider Inverter does not export any power to the grid. The maximum amount of power that can be exported is 8 kW.

To update the export mode:

1. On the left menu, click **Home**.
2. Click **System Information**.
3. Next to **Export configuration**, click the arrow.
4. Click the radio button to select the export mode.
5. If you have selected **Limit Export**, type the maximum amount of power to export.
6. Click **Save**.

Figure 27 Export configuration

The screenshot displays the Schneider Electric Installer Portal interface. The top navigation bar includes the logo, language selection (English), and user profile icons. The main content area shows the site name 'C-I Lab 1P New' and a 'View Other Site' dropdown. Below this, there are tabs for 'Overview', 'Dynamic Analysis', 'Events', and 'Firmware'. The 'Overview' tab is active, showing a 'Powerflow' diagram with a 'Live' status indicator. The diagram includes a solar panel icon labeled '7 w', a battery icon labeled '0 w', and a house icon labeled '7 w'. To the right of the diagram is a 'System Information' table with the following data:

System Information	
System Nominal Voltage	230 V
System Nominal Frequency	50 Hz
Selected Grid Code	ES-NTS
System Operating Mode	On Grid
Grid Tie Power Control Mode	Self Consumption
Export configuration	Zero Export ▾

The 'Export configuration' row is highlighted with a red border, and the 'Zero Export' dropdown is also highlighted.

Viewing Events in the Installer Portal

To view events:

1. To view the events for a specific site, click **Home** from the left menu.
 - a. Select a site from the **All Sites** drop-down menu.

Figure 28 All sites menu

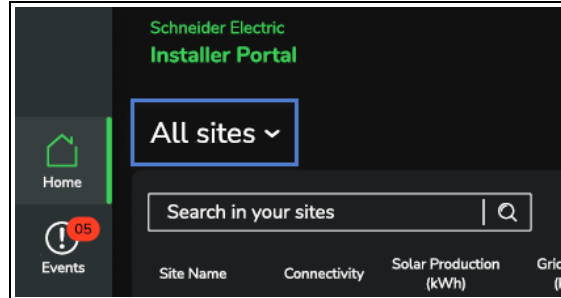

- b. Select the **Events** tab.

Figure 29 Viewing site events

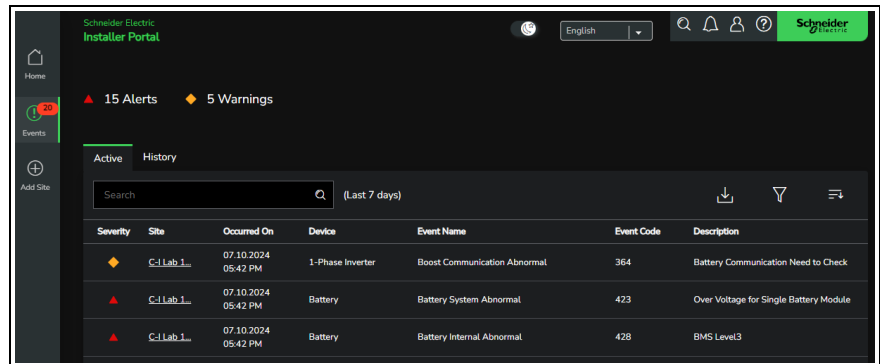

2. To see the events for all of your sites, click **Events** from the left vertical menu.

Figure 30 Events menu

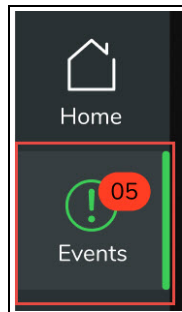

3. Click the filter icon to filter the events.

Figure 31 Event filters

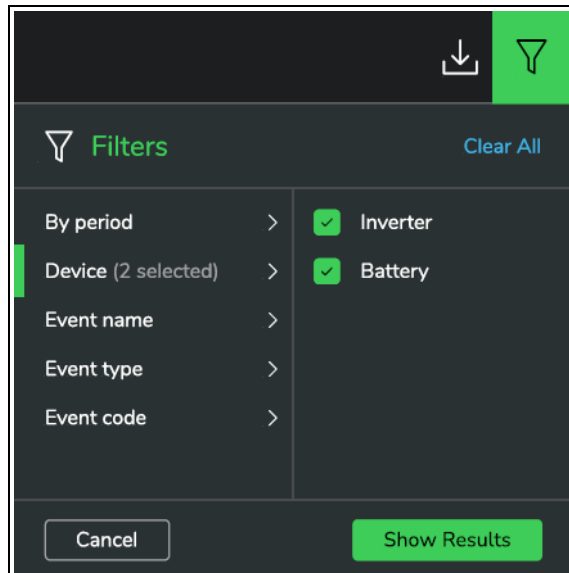

Viewing Firmware Information

After commissioning, firmware is updated automatically. You can view the firmware version using the Installer Portal, as shown below.

Figure 32 Viewing firmware information

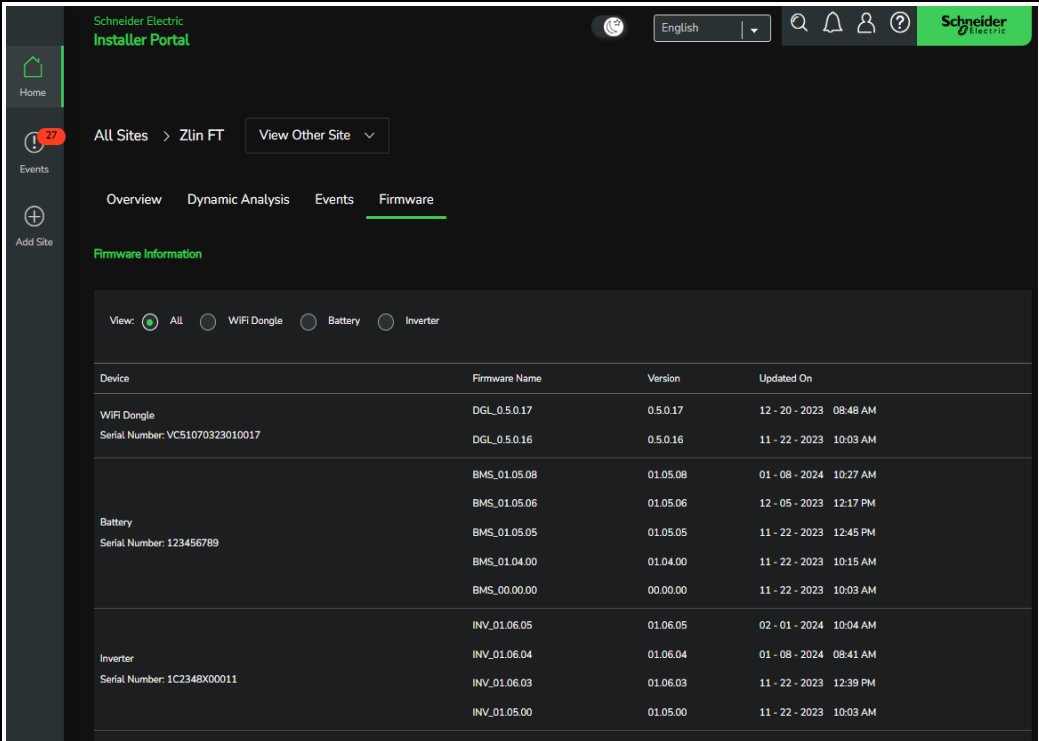

The screenshot shows the Schneider Electric Installer Portal interface. The main content area is titled "Firmware Information" and includes a filter section with radio buttons for "All", "WiFi Dongle", "Battery", and "Inverter". Below this is a table listing firmware updates for different device categories.

Device	Firmware Name	Version	Updated On
WiFi Dongle Serial Number: VC51070323010017	DGL_0.5.0.17	0.5.0.17	12 - 20 - 2023 08:48 AM
	DGL_0.5.0.16	0.5.0.16	11 - 22 - 2023 10:03 AM
Battery Serial Number: 123456789	BMS_01.05.08	01.05.08	01 - 08 - 2024 10:27 AM
	BMS_01.05.06	01.05.06	12 - 05 - 2023 12:17 PM
	BMS_01.05.05	01.05.05	11 - 22 - 2023 12:45 PM
	BMS_01.04.00	01.04.00	11 - 22 - 2023 10:15 AM
Inverter Serial Number: 1C2348X00011	BMS_00.00.00	00.00.00	11 - 22 - 2023 10:03 AM
	INV_01.06.05	01.06.05	02 - 01 - 2024 10:04 AM
	INV_01.06.04	01.06.04	01 - 08 - 2024 08:41 AM
	INV_01.06.03	01.06.03	11 - 22 - 2023 12:39 PM
	INV_01.05.00	01.05.00	11 - 22 - 2023 10:03 AM

Troubleshooting

General Troubleshooting Steps

IMPORTANT: Troubleshooting should be performed by qualified personnel.

1. Check the event code of the inverter on the app or Installer Portal. If an event message or prompt is displayed, record it before proceeding.
2. Review the event table on page 78.
3. If the inverter LED is not lit, check the following to confirm that the current state of the installation allows the device to operate properly:
 - a. The inverter is located in a clean, dry and well-ventilated location
 - b. The DC input switch is in the ON position
 - c. The cable size is appropriate
 - d. The input and output wires are connected correctly and firmly
 - e. The configuration settings are suitable for your specific installation
 - f. The Wi-Fi connections are correct and not damaged
 - g. The Wi-Fi LED is on

If all of the checks above are complete, and the event persists, contact Technical Support for further assistance. Please provide the system installation details along with the model and serial number of the product (see the labels on your inverter).

Contacting Technical Support (Spain)

To contact Technical Support in Spain, phone 930 28 99 00 or go to <https://www.se.com/es/es/work/support/customer-care/contact-schneider-electric.jsp>.

Troubleshooting and Event List

If the Schneider Inverter reports an event code in the Installer Portal, qualified personnel can follow the Service Protocols defined on page 77.

Event List

Event Code	Event Description	Service Protocol	Action Taken By
200, 201, 202, 210, 211, 212	AC over-current	Level 1	Qualified Installer
203, 204, 205, 213, 215	DC bus over-voltage	Level 1	Qualified Installer
206, 207, 220, 221, 222	PV over-current	Level 0	Homeowner, after contacting Technical Support
214, 216, 217	DC bus voltage abnormal	Level 1	Qualified Installer
219, 322	Grid abnormal	Level 0	Homeowner, after contacting Technical Support
224, 225, 226	PV over-voltage	Level 0	Homeowner, after contacting Technical Support
228, 235, 264, 265, 266, 267, 268, 269, 270, 271, 272, 276, 277, 278, 279, 280, 281, 282, 283, 284, 285, 286, 287, 291, 292, 293, 297, 298, 299, 300, 301, 302	Grid voltage abnormal	Level 0	Homeowner, after contacting Technical Support
246, 294, 295, 296	Grid frequency abnormal	Level 0	Homeowner, after contacting Technical Support
273, 274, 275, 288, 289, 290	Grid over-voltage	Level 0	Homeowner, after contacting Technical Support
303, 304	Inverter temperature abnormal	Level 1	Qualified Installer
305	Low system insulation resistance	Level 1	Qualified Installer
306, 314, 318, 319, 320, 321, 323, 325	Inverter internal abnormal	Level 1	Qualified Installer
307, 308, 309, 310, 324	Excessive current leakage	Level 1	Qualified Installer
312, 353, 354, 355, 356, 357, 358, 359, 360, 361, 362, 363, 368, 370, 371, 372, 373, 374, 375, 376, 377, 378, 379, 380, 381	Inverter internal abnormal	Level 2	Qualified Installer
350, 351, 352	Firmware version mismatch	Level 2	Qualified Installer
364	Schneider Boost communication abnormal	Level 2	Qualified Installer
365, 366	BCS/Meter communication abnormal	Level 2	Qualified Installer

Event Code	Event Description	Service Protocol	Action Taken By
367	Dongle communication abnormal	Level 2	Qualified Installer
369	Inverter internal fan abnormal	Level 3	Qualified Installer

Service Protocol Levels

Table 12 Service Protocol definitions

Service Protocol Level	Completed By	Action
Service Protocol Level 0	Homeowner, after contacting Technical Support	<ol style="list-style-type: none"> The event is caused by a condition external to the energy storage system. If the event occurs occasionally, no action is required. Generally, the inverter automatically recovers after the external conditions return to normal. If the event does not automatically recover, restart the system as follows: <ol style="list-style-type: none"> Rotate the manual DC switch on the Schneider Boost and DC switch on the Schneider Inverter 90 degrees counterclockwise to the Off position. Wait five minutes, then rotate the manual DC switch of the inverter 90 degrees clockwise to the On position. Rotate the manual DC switch of the battery 90 degrees clockwise to the On position. On the battery, press and hold the green Black Start button until the panel indicator lights start flashing yellow one by one, then release the button. If the same error code persists after the system restart, contact Technical Support to follow Service Protocol Level 2.
Service Protocol Level 1	Qualified Installer	<ol style="list-style-type: none"> Restart the system as follows: <ol style="list-style-type: none"> Rotate the manual DC switch on the Schneider Boost and DC switch on the Schneider Inverter 90 degrees counterclockwise to the Off position. Wait five minutes, then rotate the manual DC switch of the inverter 90 degrees clockwise to the On position. Rotate the manual DC switch of the battery 90 degrees clockwise to the On position. On the battery, press and hold the green Black Start button until the panel indicator lights start flashing yellow one by one, then release the button. If the same error code persists after the system restart, contact Technical Support to follow Service Protocol Level 2.

Service Protocol Level	Completed By	Action
Service Protocol Level 2	Qualified Installer	<ol style="list-style-type: none"> 1. Check the firmware version. 2. Check that all cable connections on the inverter are properly connected and show no signs of damage. 3. Restart the system as follows: <ol style="list-style-type: none"> a. Rotate the manual DC switch on the Schneider Boost and DC switch on the Schneider Inverter 90 degrees counterclockwise to the Off position. b. Wait five minutes, then rotate the manual DC switch of the inverter 90 degrees clockwise to the On position. c. Rotate the manual DC switch of the battery 90 degrees clockwise to the On position. d. On the battery, press and hold the green Black Start button until the panel indicator lights start flashing yellow one by one, then release the button. 4. If the same error code persists after the system restart, contact Technical Support to follow Service Protocol Level 3.
Service Protocol Level 3	Qualified Installer	<ol style="list-style-type: none"> 1. Follow the warranty procedure for inverter system replacement. 2. Contact the service center: 0060-1546000603 (Global Hotline).

5 Maintenance and End of Life

What's in This Chapter?

Maintenance	82
Turning Off the Inverter	82
Routine Maintenance	82
Safety Inspection	82
Disassembling and Decommissioning	83
Storage and Transportation	83
Recycling and Disposal	83

Maintenance

This section includes information about safety inspections and routine maintenance of the inverter.

Turning Off the Inverter

Before performing inverter maintenance, turn off the inverter. For more information, see "Lock-Out and Tag-Out (LOTO) Procedure" on page 38.

Routine Maintenance

The surface of the inverter can be cleaned by using a lint-free soft cloth.

NOTICE
<p>RISK OF EQUIPMENT DAMAGE</p> <ul style="list-style-type: none"> ▪ Use only a soft cloth dampened with water and mild soap to clean the inverter. ▪ Do not use solvents or chemicals that are corrosive or flammable. <p>Failure to follow these instructions can result in equipment damage.</p>

Qualified personnel should regularly inspect and maintain the inverter. See the table below for required maintenance:

Table 13 Routine maintenance

Description	Frequency
Check the heatsink at the rear of the inverter for dust and dirt accumulation, and clean the inverter if necessary.	Every 1-2 months
Check that the indicator lights on the inverter are normal.	Every 6 months
Check the DC, AC, and PE connection cables for damage or aging.	Every 6 months
Clean the inverter's front panel.	Every 6 months

Safety Inspection

Safety inspections should be conducted at least every 12 months by a qualified technician who is adequately trained and has relevant knowledge and experience. The data should be recorded in the device log. If the inverter is not working properly or any tests do not pass, the device must be repaired.

Disassembling and Decommissioning

At the end of the inverter's life, follow the instructions in this section to dispose of and recycle the inverter.

Reset the PIN Code

Follow the instructions in Wiser Home to reset the PIN code and remove the Wi-Fi credentials.

You will be prompted to scan a QR code on the Wireless LAN Smart Dongle, so ensure that the dongle is nearby when resetting the PIN code.

Disassemble the Inverter

To disassemble the inverter:

1. Follow "Lock-Out and Tag-Out (LOTO) Procedure" on page 38. Turn off all connected electrical connections and switches, and lock-out and tag-out the switches.
2. Turn the inverter's **PV Disconnect** switch to **OFF**.
3. Disconnect the inverter from the DC input and AC output. Wait five minutes for the inverter to discharge power.
4. Disconnect communication cables and monitoring devices.
5. Remove the inverter from the wall mount, and then remove the mounting bracket.

Package the Inverter

If possible, pack the inverter in its original packaging. If the original packaging is not available, an equivalent box that meets the following requirements can also be used:

- Holds up to 25 kg
- Includes handles
- Can be completely closed

Storage and Transportation

Store the inverter in a dry environment and always keep the temperature between -40°C to $+70^{\circ}\text{C}$. During storage and transportation, the inverter must be packaged, and the number of stacked inverter packages must not exceed four.

Recycling and Disposal

Always follow local guidelines for recycling and disposal.

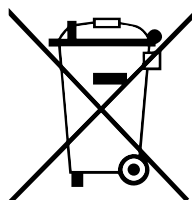

Electric appliances marked with the symbol shown must be professionally treated to recover, reuse, and recycle materials in order to reduce negative environmental impact. When the product is no longer usable, the consumer is legally obligated to ensure that it is collected separately under the local electronics recycling and treatment scheme.

6 Specifications

What's in This Chapter?

Specifications	86
----------------------	----

Specifications

Note: Specifications are subject to change without notice.

Output	Schneider Inverter HY5K1EU1	Schneider Inverter HY6K1EU1	Schneider Inverter HY8K1EU1
AC Output (Grid Tied)			
Rated AC output power	4600 W	6000 W	8000 W
Maximum apparent AC power	5000 VA	6600 VA	8800 VA
AC rated output voltage ¹	230 VAC		
AC output voltage range ¹	196 V ~ 253 VAC		
AC frequency range ¹	50±5 Hz, 60±5 Hz		
Maximum continuous output current	23 A	30 A	37 A
Grids Supported	L / N / PE		
Current total harmonic distortion (Rated Power)	≤3%		
Power Factor	0.8 lead to 0.8 lag		
Utility monitoring, islanding protection, country configurable thresholds	Yes		
AC Over Voltage Category	III		
Charge battery from AC	Yes		
Typical Nighttime Power Consumption ²	<5 W		
Note 1: The rating and range of AC voltage and frequency are defined by the grid code setting.			
Note 2: Tested at Schneider Electric's lab under sleep mode.			

Input	Schneider Inverter HY5K1EU1	Schneider Inverter HY6K1EU1	Schneider Inverter HY8K1EU1
DC (Solar PV Input & Optimization)			
Maximum oversizing PV array power ³	6900 Wp	9000 Wp	10000 Wp
Maximum number of MPPTs	2	3	3
Strings per MPPT	1		
DC oversizing (Allowed DC/AC ratio)	1.5	1.5	1.25
Rated operation voltage	360 V		
MPPT tracking voltage range (full power)	250 V - 480 V	200 V - 480 V	280 V - 480 V
Operating voltage range ⁴	80 - 500 V		
Maximum open circuit voltage	500 V		
Maximum input voltage ⁵	600 V		

Input	Schneider Inverter HY5K1EU1	Schneider Inverter HY6K1EU1	Schneider Inverter HY8K1EU1
Start-up voltage		100 V – 500 V	
Maximum input current	13.5 Adc * 2	13.5 Adc * 3	13.5 Adc * 3
Maximum input short-circuit current	20 Adc * 2	20 Adc * 3	20 Adc * 3
Voltage measurement accuracy		±3 V	
PV array configuration		Unearthed (ungrounded)	
PV overvoltage category		II	
2-pole disconnection		Yes	
DC (Battery)			
Compatible battery	Schneider Boost (BATB3KEU3), 7 ~ 20 kWh nominal energy		
Number of batteries per inverter	1 Schneider Boost (2 - 6 modules, 7 ~ 20 kWh)		
Rated port voltage		400 V	
Port voltage range		360 – 480 V	
Maximum continuous power	4680 W	5760 W	7920 W
Maximum port current	13 Adc	16 Adc	22 Adc
2-pole disconnection		Yes	
Battery to inverter communication	[BMU]--CAN--[BCU]--CAN--[DCDC]--RS485--[Inverter]		
Note 3: The cause of PV oversizing is due to the typical production efficiency of the PV roof.			
Note 4: If the DC input voltage is not within the operating voltage range, a system event may occur and the inverter may not work properly.			
Note 5: The maximum input voltage is the upper limit of the DC voltage. A higher input DC voltage may damage the inverter.			
Conversion Efficiency	Schneider Inverter HY5K1EU1	Schneider Inverter HY6K1EU1	Schneider Inverter HY8K1EU1
Peak		97.4 %	
EU efficiency		96.7 %	

Protection and Features	Schneider Inverter HY5K1EU1	Schneider Inverter HY6K1EU1	Schneider Inverter HY8K1EU1
Smart Energy Capabilities			
Production metering	Collect current and voltage parameters of inverter AC port, and calculate real-time power and quantity of electricity. Backup control system does not have metering devices.		
Backup and battery storage	Through backup control system		
EV Charging	AC power supply for EVSE		
Additional Features			
Supported communication Interfaces ⁶	RS485, CAN, WLAN-FE / 4G (optional)		
Inverter commissioning	Commissioning app		
Transformerless, ungrounded	Yes		
Maximum initial short-circuit current	n/a		
DC ground-fault isolation detection	100 k Ω sensitivity		
Anti-island protection	Supported		
DC reverse polarity protection	No, only physical fool-proofing connector		
PV port reverse polarity protection	No, only physical fool-proofing connector		
Insulation resistance detection	>1M Ω		
Ground fault detection	Residual Current Monitoring (RCMU)		
AC short-circuit protection	Yes, integrated		
AC overcurrent protection	Yes, integrated		
Battery port overcurrent protection	No, but integrated in the battery assembly		
Overtemperature protection	Yes, integrated		
DC surge protection	Class 2 test level		
AC surge protection	Class 3 test level		
AC overvoltage protection	Yes, integrated		
PV DC switch	Yes		
Battery switch	No, but integrated in battery assembly		
Note 6: RS485 is the communication bus between devices. CAN is reserved for a future application scenario. WLAN-FE (including Wi-Fi and Bluetooth) is used as a data reporting intermediary. 4G solution is in development.			

Regulatory	Schneider Inverter HY5K1EU1	Schneider Inverter HY6K1EU1	Schneider Inverter HY8K1EU1
Safety	IEC 62109-1/-2		
Emissions EMC	IEC61000-6-1, IEC61000-6-3		
Grid connection standards	RD1699, RD647, RD413, UNE 217002, NTS V2.1 (Spain)		
RoHS, ReACH, and WEEE directives	Yes		

Installation Specifications	Schneider Inverter HY5K1EU1	Schneider Inverter HY6K1EU1	Schneider Inverter HY8K1EU1
AC side conduit specification (voltage / area)	450 Vac / 6 mm ²	450 Vac / 10 mm ²	450 Vac / 10 mm ²
Battery side conduit specification (voltage / area)	1000 Vdc / 4 mm ²	1000 Vdc / 4 mm ²	1000 Vdc / 4 mm ²
PV side conduit specification (voltage / area)	1000 Vdc / 4 mm ²	1000 Vdc / 4 mm ²	1000 Vdc / 4 mm ²
Dimensions (H×W×D)	400 × 484 × 177 mm		
Net weight	18 kg		
Noise ⁷	<45 dBa		
Cooling method	Natural convection		
Mounting	Wall mounted, brackets provided		
Operating temperature	-25 °C to 60 °C		
Ingress Protection Rating	IP 65		
Relative humidity	0% ~ 95% RH		
Altitude	0~4000 m above mean sea level or equivalent		
Recommended AC protection device	32 A	40 A	50 A
Note 7: Testing conditions: 1 m test distance at the Schneider Electric lab.			

Schneider Electric

201 Washington St, Suite 2700, One Boston Place
Boston, Massachusetts 02108
United States
<https://www.se.com/>

Service Address

35 Rue Joseph Monier
92500 Rueil-Malmaison
France

As standards, specifications, and designs change from time to time,
please ask for confirmation of the information given in this
publication.

For other country details please contact your local Schneider
Electric Sales Representative or visit the Schneider Electric website
at: <https://www.se.com/>

© 2024 Schneider Electric. All Rights Reserved.

