Industrial pressure and vacuum switches

XMLA, XMLB, XMLC, XMLD, 9012G and 9016G

Catalog



Simply easy!™

Selection guide pages 2 and 3
Selecting a pressure switch pages 4 and 5
Terminology pages 6 and 7

XML electromechanical pressure and vacuum switches

- Introduction pages 8 to 18
- Selection and specifications pages 19 to 56
- Accessories page 57
- Dimensions pages 58 to 61
- Materials in contact with fluid pages 62 and 63

9012G pressure switches

- Introduction pages 64 to 66
- Technical overview pages 66 to 69
- Renewal parts page 75
- Selection and specifications pages 70 to 77
- Modifications page 77
- Dimensions pages 80 to 82

9016G vacuum switches

- Selection and specifications pages 78 and 79
- Modifications pages 79 and 83
- Dimensions page 83

Product reference index pages 84 and 85



Electromechanical pressure and vacuum switches

XML range

| | | | | |
|--------------|----------------------|--|--|--|
| Applications | Type of installation | Control circuits | | |
| | Media controlled | Air, water, hydraulic oils, corrosive fluids, viscous products | | |
| | Type of operation | Fixed differential: detection of a single threshold | Adjustable differential: regulation between two thresholds | Dual-stage switches: fixed differential, detection at each threshold |



| | | | |
|-----------------------|--|--|---|
| Fluid characteristics | Air, fresh water, sea water, corrosive fluids, viscous products, up to 320 °F (160 °C) depending on model | | |
| Size (pressure range) | -1 to 500 bar (-14.5 to 7250 psi) | | |
| Type of contacts | 1 C/O single-pole, snap action | 2 C/O single-pole, simultaneous, snap action | 2 C/O single-pole, staggered, snap action |
| Degree of protection | IP66 with terminal connections IP65 with plug-in connector | IP66 with terminal connections | IP66 with terminal connections IP65 with plug-in connector |
| Agency listings | CCC, BV, cULus | | |
| Electrical connection | Screw terminals: 1 tapped entry: 1/2 NPT; M20 x 1.5 mm for ISO conduit/cable; or PG 13.5 conduit/cable entry. Connector: DIN 43650, M12 | | |
| Pressure connection | G 1/4 (BSP female), 1/4" NPTF, PT 1/4 (JIS B0203) | | |
| Type reference | XMLA | XMLB | XMLC |
| Pages | 19 to 56 | | |

Note: For electromechanical pressure and vacuum switches with alternative tapped cable or fluid entries, consult our Customer Care Center.

Industrial pressure and vacuum switches

9012G and 9016G ranges

| | | | | | | |
|--------------|----------------------|---|--|--|--|--------------------------------------|
| Applications | Type of installation | Control circuits | | | | Power circuits |
| | Media controlled | Air, water, hydraulic oils (1), gases and steam | | | | |
| | Type of operation | Fixed differential: detection of a single threshold | Adjustable differential: regulation between two thresholds | Differential-pressure (change in the difference between two pressures) | Dual-stage switches: Fixed differential, detection at each threshold | Vacuum switches for control circuits |



| | | | | | |
|--|---|---|---------------------|------------------------------------|--------------------|
| Fluid characteristics | Up to 248 °F (120 °C) | | | | |
| Size (pressure range) | Diaphragm: 0.2–675 psi on falling pressure Piston actuated: 20–9,000 psi on falling pressure | | 0–28.7 inHg | 0–25 inHg | |
| Type of contacts | SPDT or DPDT double break contacts; SPDT single break contacts | | | DPST (SPDT for Form H) | |
| Degree of protection | NEMA 1, 4, 4X, 13, 7 or 9, depending on model | | | | |
| Agency listings | UL Listed and CSA certified as industrial control equipment | | | | |
| Electrical connection (enclosed devices) | 1/2"-14 NPTF, PG13.5, or ISO M20; 3/4"-14 NPTF available only on NEMA 7 and 9. NEMA 1 is 1/2" conduit entry, unthreaded. | | 1/2"-14 NPT | 3 x 1/2" conduit entry, unthreaded | |
| Pressure connection | G1/4 (BSP) female, 1/4"-18 NPTF, 1/4-18 NPT internal or external (depending on model), 1/2"-14 NPT | | | | |
| Type reference | 9012GD, 9012GE, 9012GF, 9012GR, 9012GT | 9012GA, 9012GB, 9012GC, 9012GN, 9012GP, 9012GQ | 9012GGW, 9012GHW | 9012GKW, 9012GMW | 9016GAW 9016GVG |
| Pages | 70 to 79 | | | | |

(1) The hydraulic fluids used for laboratory testing are equivalent to SAE 30 W oils. If oils have less viscosity than this type of oil, leakage can be expected. Telemecanique Sensors does not have test data to support or predict fluid bypass with oils less than SAE 30W.

Steps for selecting a pressure switch



The deciding factors in the selection of a pressure switch for use on control circuits(1) depend on the requirements of the application. Consider the following requirements to help determine the appropriate commercial reference for your application.

1. Setpoints: Do you want to control/monitor one setpoint or two?

- One setpoint: fixed differential
- Two setpoints: adjustable differential

Fixed differential

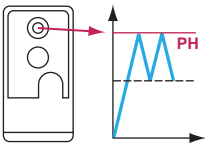

2. Fluids: What fluids do you want to control?

- Hydraulic oil, air, fresh water ≤ 70 °C (158 °F)
- Steam
- Hydraulic oil, air, fresh water ≤ 160 °C (320 °F)
- Corrosive fluid ≤ 160 °C (320 °F)
- Sea water ≤ 70 °C (158 °F)
- Viscous fluid ≤ 160 °C (320 °F)
- Sea water ≤ 160 °C (320 °F)

Adjustable differential

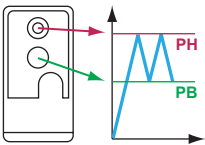

Ensure that the wetted parts of the switch are compatible with the system fluid.

3. Pressure range: What pressure range does the system experience?

Note: Select pressure settings that fall within the middle 80% of the pressure range. The pressure applied during a normal cycle should never exceed the maximum range value listed for the switch. Pressure surges should be less than the maximum allowable pressure listed for the switch.

| Rated pressure | | | |
|----------------|---------------|-----------------------------|-----------------|
| XML | | 9012G / 9016 G (a) | |
| psi | bar | psi | bar |
| -14.5 to -4.06 | -1 to -0.28 | 0 to 28 inHg | |
| -14.5 to -2.03 | -1 to -0.14 | 0 to 25 inHg | |
| -2.9 to -0.029 | -0.2 to -0.02 | 5 to 25 inHg (9016GVG only) | |
| -7.25 to 72.5 | -0.5 to 5 | 0.2 to 10 | 0.01 to 0.69 |
| 0 to 0.725 | 0 to 0.05 | 1 to 40 | 0.07 to 2.76 |
| 0 to 5.075 | 0 to 0.35 | 1.5 to 75 | 0.10 to 5.17 |
| 0 to 14.5 | 0 to 1 | 3 to 150 | 0.21 to 10.34 |
| 0 to 36.25 | 0 to 2.5 | 5 to 250 | 0.34 to 17.24 |
| 0 to 58 | 0 to 4 | 13 to 425 | 0.90 to 29.30 |
| 0 to 145 | 0 to 10 | 20 to 675 | 1.38 to 46.54 |
| 0 to 290 | 0 to 20 | 20 to 1000 | 1.38 to 68.95 |
| 0 to 507.5 | 0 to 35 | 90 to 2900 | 6.21 to 199.95 |
| 0 to 580 | 0 to 40 | 170 to 5600 | 11.72 to 386.11 |
| 0 to 1015 | 0 to 70 | 270 to 9000 | 18.62 to 620.53 |
| 0 to 2320 | 0 to 160 | 0 to 75 (b) | 0 to 5.17 (b) |
| 0 to 4350 | 0 to 300 | 0 to 175 (b) | 0 to 12.07 (b) |
| 0 to 7250 | 0 to 500 | 0 to 500 (b) | 0 to 34.47 (b) |
| | | 0 to 5000 (b) | 0 to 344.74 (b) |

(a) For 9016G vacuum switches, the unit of rated pressure is inHg.

(b) Pressure switches for differential-pressure operation.

4. Surges: How frequent are surges in your system, and what is their maximum pressure level? Applications experiencing frequent or high-pressure surges may require a device with a higher pressure range.

5. Differential: The required differential may exclude some pressure range choices.

(1) For switches used on power circuits, see catalog 9013CT9701, *Commercial Pressure Switches, Class 9013 Types F and G.*

6. **Enclosure:** What type of enclosure do you need?
- Open style
 - NEMA Type 1
 - NEMA Type 7, 9
 - NEMA Type 4, 4X, 13 / IP66, IP65
7. **Output:** What output type do you require?
- SPDT contacts, 1 N/O, 1 N/C
 - 2 SPDT contacts, 1 N/O, 1 N/C
 - Dual stage, 1 SPDT contact each stage, 1 N/O, 1 N/C
 - Horsepower rated, 9016GVG vacuum switch only
8. **Electrical connection:** What type of electrical connection do you require?
- 1/2"- 14 NPTF
 - ISO M20 metric threads
 - Type 13 (PG 13.5) metric threads
 - 3/4"-14 NPTF (available only on NEMA 7 & 9)
 - No threaded connection (open style or NEMA 1 only)
9. **Pressure connection:** What type of pressure connection do you require?
- 1/4"- 18 NPTF (female)
 - 1/2" - 14 NPT
 - G 1/4 BSP (female) metric thread
 - PT 1/4 (JIS B0203)
 - 7/16"-20 UNF-2B

10. **Special features:** Do you require any special features?

See the modification table on page 83 for available modifications for 9012 and 9016G pressure switches. (Form designations are added to the end of the part number of the standard device for these products.) Some examples are:

- Pilot light
- Prewired receptacles
- External range adjustment
- Range scale window
- Special factory pressure settings
- Pressure connections

When switches must be factory set and only one setting is identified, specify whether this setting is on rising or falling pressure. See "Special factory setting specified (If indicating only one special setting, specify whether this setting is on increasing or decreasing pressure.)" in the modification table on page 83.

11. **System response time**

- If system response time is critical, select a switch with a volumetric displacement that is compatible with the overall system. See the table below .

| Volumetric displacement of 9012G pressure switches | | |
|--|---|---|
| Class 9012 Type | Volumetric displacement (1) (in ³) | Volumetric displacement (1) (cm ³) |
| GAR, GAW, GDR, GDW-1& 21 | 0.20774 | 3.40422 |
| GAR, GAW, GDR, GDW-2 & 22 | 0.07040 | 1.15385 |
| GAR, GAW, GDR, GDW-4 & 24 | 0.04320 | 0.70805 |
| GAR, GAW, GDR, GDW-5 & 25 | 0.02144 | 0.35140 |
| GAR, GAW, GDR, GDW-6 & 26 | 0.01376 | 0.22553 |
| GBR, GBW, GER, GEW-1 & 21 | 0.00200 | 0.13112 |
| GBR, GBW, GER, GEW-2 & 22 | 0.00512 | 0.08392 |
| GCR, GCW, GFR, GFW-1 & 21 | 0.00320 | 0.05245 |
| GCR, GCW, GFR, GFW-2 & 22 | 0.00117 | 0.01922 |
| GCR, GCW, GFR, GFW-3 & 23 | 0.00060 | 0.00924 |
| GCR, GCW, GFR, GFW-4 & 24 | 0.00037 | 0.00612 |

(1) Figures shown are total displacement. When the switch is operated between settings only, displacement is 1/3 of the values shown.

Terminology

Measuring range

The measuring range (MR) of a pressure sensor corresponds to the difference between the upper and lower values measured by the load cell. It ranges between 0 and the pressure corresponding to the size of the sensor.

Operating range

The operating range of a pressure transmitter corresponds to its measuring range. Within this range, its analog output signal varies between 4 and 20 mA or 0 and 10 V, and is proportional to the measured pressure.

The operating range of a pressure or vacuum switch is the difference between the values of the minimum low setpoint (PB) and the maximum high setpoint (PH).

Precision

This includes linearity, hysteresis, repeat accuracy, and setting tolerances. It is expressed as a percentage of the measuring range of the load cell (%MR).

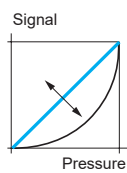

The linearity is the maximum deviation between the real transmitted curve and the ideal curve.

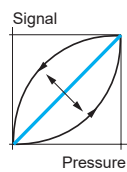

The hysteresis is the maximum deviation between the rising pressure curve and the falling pressure curve.

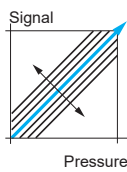

The repeat accuracy is the maximum drift encountered at varying pressures under given conditions.

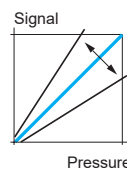
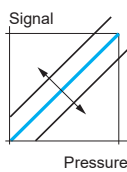

The setting tolerances are the manufacturer's tolerances with regard to the zero point and sensitivity (gradient of output signal curve from pressure transmitter).

Temperature drift

The precision of a pressure sensor is susceptible to variation due to the operating temperature.

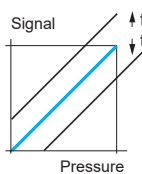

Zero point drift, proportional to the temperature, is expressed as %MR/°C.

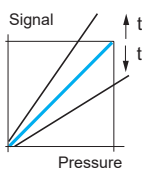

Sensitivity drift, proportional to the temperature, is expressed as %MR/°C.

Terminology (continued)

Switching point on rising pressure (PH)

This is the upper pressure setting at which the output of the electronic pressure or vacuum switch changes state on rising pressure.

Switching point on falling pressure (PB)

This is the lower pressure setting at which the output of the electronic pressure or vacuum switch changes state on falling pressure.

Differential

This is the difference between the switching point on rising pressure (PH) and the switching point on falling pressure (PB). The low point can be set at the values indicated on the operating curves shown on the product pages.

Switches with fixed differential

Depending on the switch, either the high or low operating point is adjustable, and the other operating point follows. The window is fixed.

Switches with adjustable differential

An adjustable differential allows independent setting of both operating points.

Spread

For dual-stage switches, the spread indicates the difference between the two operating points on rising pressure (PH2 and PH1) and, for vacuum switches, the difference between the two operating points on falling pressure (PB2 and PB1).

Differential-pressure sensing

Switches for differential-pressure sensing measure the difference between two pressures.

Size

Pressure transmitters and pressure switches

This is the maximum value of the operating range.

Vacuum transmitters and vacuum switches

This is the minimum value of the operating range.

Accuracy (switches with setting scale)

The tolerance between the point at which the switch actuates its contacts and the value indicated on the setting scale. Where very high setting accuracy is required (initial installation of the product), it is recommended that you use separate measuring equipment (pressure gauge, etc.).

Repeat accuracy

This is the variation in the operating point between several successive operations, or the tolerance between two consecutive switching operations.

Drift (F)

The tolerance of the operating point throughout the entire service life of the switch.

Maximum allowable pressure

The maximum value of an accidental pressure surge of very short duration (a few milliseconds).

Maximum permissible accidental pressure

This is the maximum pressure (excluding pressure surges) that the sensor can occasionally withstand without permanent damage.

Maximum allowable pressure per cycle (Ps)

The maximum pressure level per cycle that the switch can withstand for optimum service life.

Surge

A surge is a high rate of rise in pressure, normally of short duration, caused by starting a pump or by opening and closing a valve. Depending on frequency and duration, surge can reduce service life. Extremely high rates of rise in pressure can be damaging even if they are within the limits of the maximum allowable pressure.

Destruction pressure

Also called *burst pressure*, the destruction pressure is the pressure value which, if exceeded, is likely to cause serious damage to the sensor—such as leaking, bursting, or permanent damage.

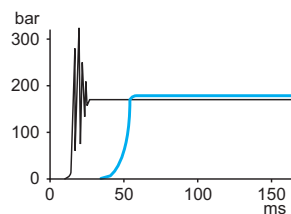
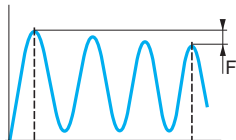
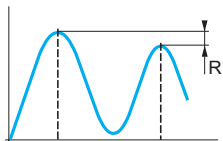
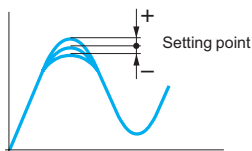

Example 1: With destructive (burst) pressure level

— Without damping device
— With damping device

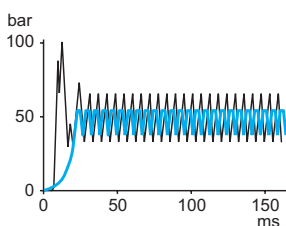

Example 2: With destructive (burst) pressure level and destructive pressure oscillations

Electromechanical pressure and vacuum switches

XML range

Introduction

XML pressure and vacuum switches for control circuits are used to control the pressure of hydraulic oils, fresh water, sea water, air, steam, corrosive fluids, or viscous products, up to 7250 psi (500 bar).

- **XMLA** pressure and vacuum switches have a fixed differential and are for detection of a single threshold. They incorporate a 1 C/O single-pole contact.
- **XMLB** pressure and vacuum switches have an adjustable differential and are for regulation between two thresholds. They incorporate a 1 C/O single-pole contact.
- **XMLC** pressure and vacuum switches have an adjustable differential and are for regulation between two thresholds. They incorporate two C/O single-pole contacts.
- **XMLD** pressure and vacuum switches are dual-stage switches, each stage with a fixed differential, and are for detection at each threshold. They incorporate two C/O single-pole contacts (one per stage).

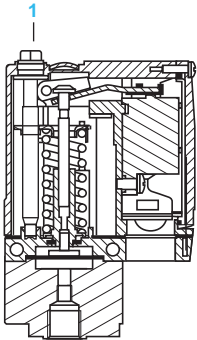

XMLA

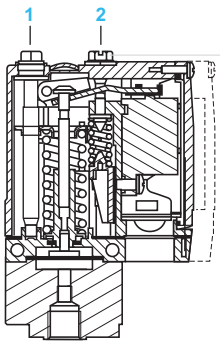

XMLB, XMLC

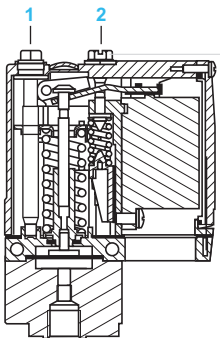

XMLD

Setting

XMLA: pressure and vacuum switches with fixed differential

- **Rising pressure**—Operating point PH is set by adjusting the red screw **1**.
- **Falling pressure**—Operating point PB is not adjustable.

The difference between the trip and reset points of the contact is the inherent differential of the switch (contact differential, friction, etc.).

XMLB and XMLC: pressure and vacuum switches with adjustable differential

When setting the pressure and vacuum switches, first adjust the operating point on rising pressure (PH), then the operating point on falling pressure (PB).

- **Rising pressure**—Operating point PH is set by adjusting the red screw **1**.
- **Falling pressure**—Operating point PB is set by adjusting the green screw **2**.

XMLD: dual-stage pressure and vacuum switches with fixed differential for each threshold

Operating point on rising pressure of stage 1 and stage 2

- **First stage** operating point on rising pressure (PH1) is set by adjusting the red screw **1**
- **Second stage** operating point on rising pressure (PH2) is set by adjusting the blue screw **2**.

Operating point on falling pressure

The operating points on falling pressure (PB1 and PB2) are not adjustable.

The difference between the trip and reset points of each contact is the inherent differential of the switch (such as contact differential or friction).

Electromechanical pressure and vacuum switches

XML range

| Specifications | |
|--|--|
| Environmental specifications | |
| Conformity to standards | CE, UKCA, IEC/EN/UL/CSA 60947-5-1 |
| Product certifications | CCC, BV, cULus |
| Ambient air temperature, °F (°C) | For operation: -13 to +158 (-25 to +70). Storage: -40 to +158 (-40 to +70) |
| Fluids or products controlled | Hydraulic oils, air, fresh water, sea water, 32–320 °F (0 to 160 °C), depending on model Steam, corrosive fluids, viscous products, 32–320 °F (0 to 160 °C), depending on model |
| Materials | Case: zinc alloy. Component materials in contact with fluid: see page 62. |
| Operating position | All positions |
| Vibration resistance | 4 gn (30–500 Hz) conforming to IEC 68-2-6 except XMLL35 , XML001 and XMLBM03 : 2 gn |
| Shock resistance | 50 gn conforming to IEC 68-2-27 except XMLL35 , XML001 and XMLBM03 : 30 gn |
| Electric shock protection | Class I conforming to IEC 1140 |
| Degree of protection | Screw terminal models: IP66 conforming to IEC/EN 60529 Connector models: IP65 conforming to IEC/EN 60529 |
| Operating rate (operating cycles/minute) | Piston version switches: up to 60 cycles/minute for temperatures greater than 32 °F (0 °C) Diaphragm version switches: up to 120 cycles/minute for temperatures greater than 32 °F (0 °C), |
| Repeat accuracy | < 2% |
| Pressure connection (1) | <ul style="list-style-type: none"> G 1/4 (BSP female) 1/4"-18 NPTF female PT 1/4 (JIS B0203). |
| Electrical connection (1) for screw terminal models | <ul style="list-style-type: none"> 1/2" NPT electrical connections ISO M20 x 1.5 tapped entry DIN Pg 13.5 (n° 13) tapped entry Connector models, either M12 or DIN 43650 A: please consult our Customer Care Center. |

| Contact block specifications | |
|--|--|
| Rated operational specifications | ~ AC-15; B300 (Ue = 240 V, Ie = 1.5 A - Ue = 120 V, Ie = 3 A) --- DC-13; R300 (Ue = 250 V, Ie = 0.1 A) |
| Rated insulation voltage | Ui = 500 V conforming to IEC/EN Ui = 300 V conforming to UL/CSA |
| Rated impulse withstand voltage | Uimp = 6 kV |
| Type of contacts Silver tipped contacts | XMLA and XMLB : 1 C/O single-pole contact (4 terminal), snap action XMLC : 2 C/O single-pole contacts (8 terminal), simultaneous, snap action XMLD : 2 C/O single-pole contacts (8 terminal), staggered, snap action |
| Short-circuit protection | 10 A cartridge fuse type gG (gl) |
| Connection | Screw clamp terminals. Clamping capacity, min: 1 x 0.2 mm ² , max: 2 x 2.5 mm ² |

| Electrical durability Utilization categories AC-15 and DC-13 | XMLA and XMLB AC supply ~ 50/60 Hz ~ Inductive circuit, Ithe = 10 A | | XMLC and XMLD AC supply ~ 50/60 Hz ~ Inductive circuit, Ithe = 10 A | | | | | | | |
|---|--|---|---|----|-----|---------|---|----|----|-----|
| | Operating rate: 3600 operating cycles/hour Load factor: 0.5 | | | | | | | | | |
| | DC supply --- Power broken in W for 1 million operating cycles | | DC supply --- Power broken in W for 5 million operating cycles | | | | | | | |
| | Voltage | V | 24 | 48 | 120 | Voltage | V | 24 | 48 | 120 |
| | ~ W | W | 31 | 29 | 26 | ~ W | W | 10 | 7 | 4 |

(1) See page 18, "Interpreting the reference for XML Devices" for more information on specifying the electrical and pressure connections.

Electromechanical pressure and vacuum switches

XML range

Function

Pressure and vacuum switches control or regulate pressure or vacuum levels in hydraulic or pneumatic systems. They transform the pressure change into a digital electrical signal when the preset operating points are reached.

Switches for control circuits

Switches with control-duty rated electrical contacts, designed for control of contactors, relays, power valves, PLC inputs, etc.

Switches for power circuits

Switches with power electrical contacts (1, 2, or 3 pole) designed for direct switching of single-phase or three-phase motors (pumps, compressors, etc.).

Pressure switch operating principle

Fixed Differential: Detection of a Single Threshold

Fixed differential switches have a single adjustable setting point (either PH or PB). The differential between the high and low points (PH-PB) depends on the construction of the switch. It is not adjustable.

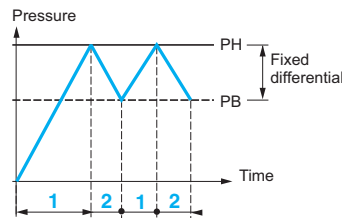

— Adjustable value
 --- Nonadjustable value

PH = High point (on rising pressure)
 PB = Low point (on falling pressure)

Example: Contact schematics of XMLA

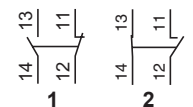

Adjustable Differential: Regulation between Two Thresholds

Adjustable differential switches have setting points for both the high point (PH) and the low point (PB). Both of these points can be independently adjusted.

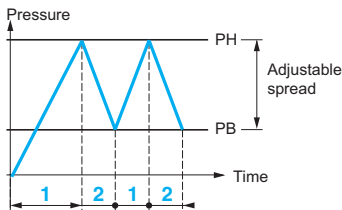

— Adjustable value

PH = High point (on rising pressure)
 PB = Low point (on falling pressure)

Example: Contact schematics of XMLB

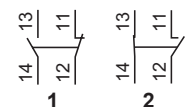

Dual-Stage: Detection of Two Thresholds

Dual-stage switches allow two distinct levels of control to be monitored with one device. Each stage allows detection of a single threshold with a single setting point (fixed differential). Both these points can be independently adjusted. However, for both stages, the differential between the high point and the low point (PH1-PB1 and PH2-PB2) is fixed and depends on the construction of the switch.

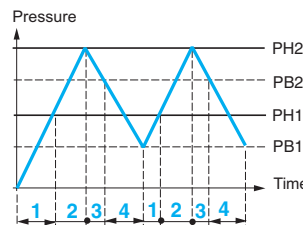

— Adjustable value
 --- Nonadjustable value

PH = High point (on rising pressure)
 PB = Low point (on falling pressure)

Example: Contact schematics of XMLD



Fixed differential

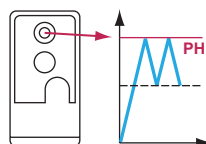

Adjustable differential

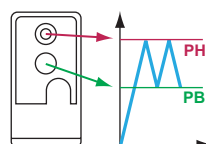

Electromechanical pressure and vacuum switches

XML range

Vacuum switch operating principle

Detection of a single threshold

The switches for detection of a single threshold (fixed differential) have a single adjustable setting point (PH). The differential between the high and low points (PH–PB) depends on the inherent characteristics of the switch. It is not adjustable.

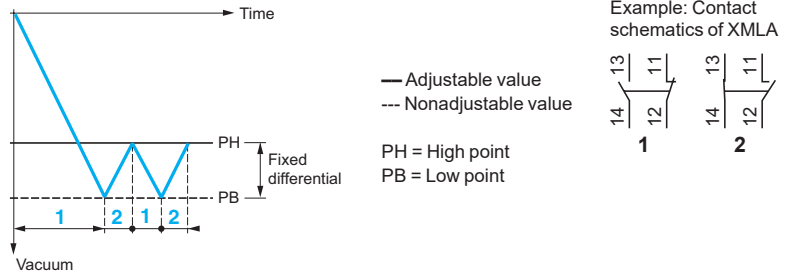

Regulation between two thresholds

The switches for regulation between two thresholds (adjustable differential) have both a high point setting (PH) and a low point setting (PB). Both of these points can be independently adjusted.

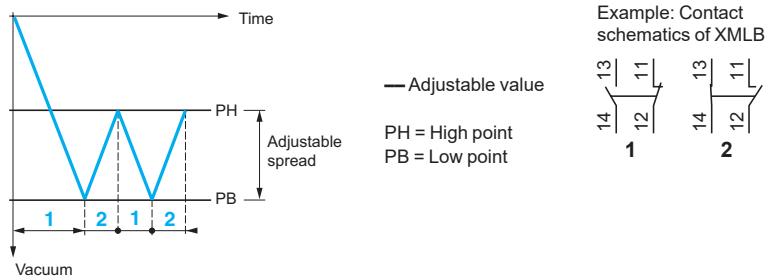

Detection of two thresholds

The dual-stage switches, for detection at each threshold, have an adjustable high point setting for each stage (PH1 and PH2). Both of these points can be independently adjusted.

For both stages, the differential between the high point and the low point (PH1–PB1 and PH2–PB2) depends on the inherent characteristics of the switch. It is not adjustable.

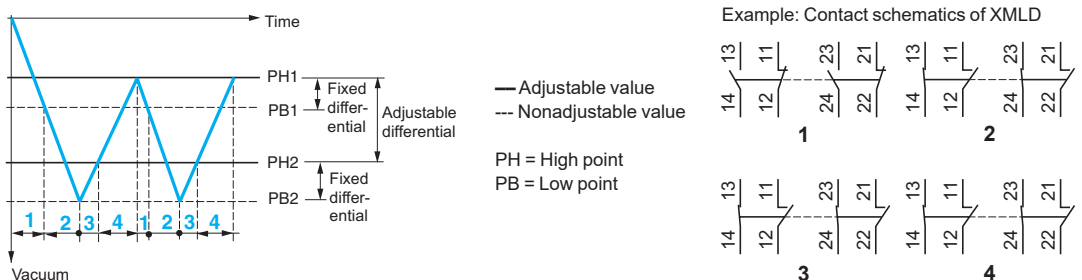

Maximum allowable accidental pressure

The maximum accidental pressure of XML switches is equal to at least 2.25 times the switch size.

If accidental overpressures occur and their duration is less than 50 milliseconds, the pressure damping device incorporated in the XML switches (sizes 10 bar and greater) reduces the effect.

Electromechanical pressure and vacuum switches

XML range

Application range of pressure and vacuum switches types XML, XMA and XMX, for control circuits

On standard loads: Continuous duty, frequent switching.

Insulation voltage limit

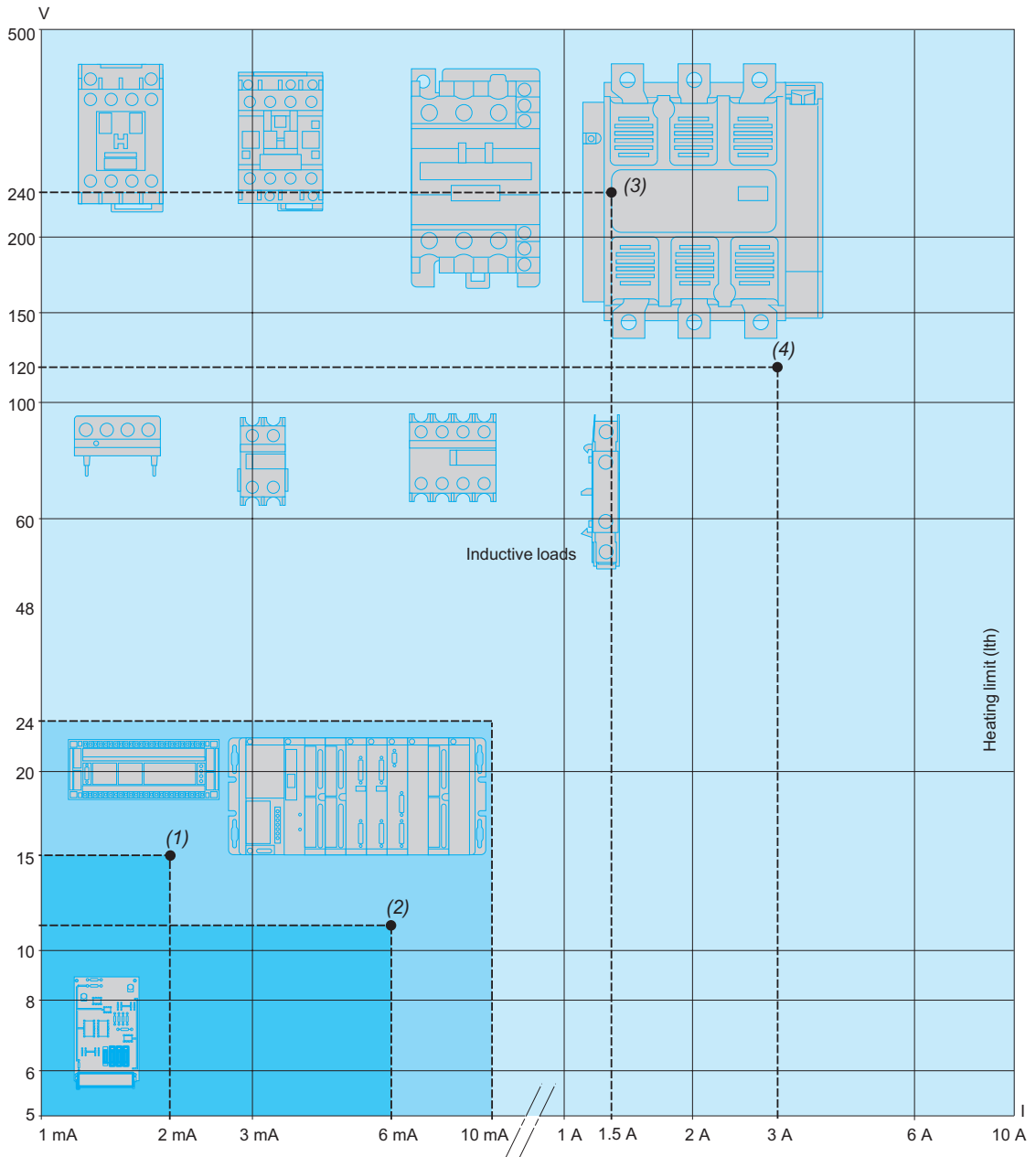

(1) Standard PLC input, type 1

(2) Standard PLC input, type 2

(3) Switching capacity, utilization category AC-15, DC-13

| | | |
|-------------|-------|-------|
| B300 | 240 V | 1.5 A |
| R300 | 250 V | 0.1 A |

(4) Switching capacity, utilization category AC-15, DC-13

| | | |
|-------------|-------|--------|
| B300 | 120 V | 3 A |
| R300 | 125 V | 0.22 A |

PLC: programmable logic controller

On small loads: The use of electromechanical pressure and vacuum switches with programmable logic controllers is becoming more prevalent. On small loads, the switches maintain a failure rate of less than 1 for 100 million operating cycles. Results may vary depending on application.

Electromechanical pressure and vacuum switches

XML range

Selecting the switch size

After establishing the type of switch required for the application (single threshold detection or regulation between two thresholds), the selection of its size depends on the following criteria:

- the differential: difference between the high point (PH) and the low point (PB),
- the maximum pressure allowable per cycle,
- repeat accuracy, precision and minimum drift.

Selecting a fixed differential pressure switch for detecting a single threshold

Main criterion: minimum differential

Example: for a selected high point (PH) of 7 bar

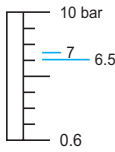

XMLA010...
Differential = 0.5 bar

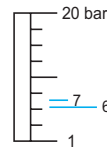

XMLA020...
Differential = 1 bar

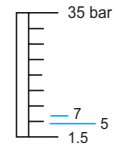

XMLA035...
Differential = 2 bar

Select an XMLA010... (the lowest size)

Main criterion: tolerance to overpressures

Example: for a selected high point (PH) of 12 bar

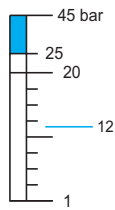

XMLA020...
Allowable accidental overpressure = 45 bar

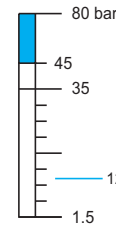

XMLA035...
Allowable accidental overpressure = 80 bar

Select an XMLA035... (the highest size)

Main criterion: repeat accuracy, precision and minimum drift

Example: for a selected high point (PH) of 18 bar

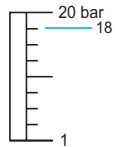

XMLA020...
Adjustable from 1–20 bar

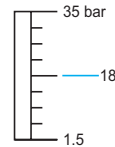

XMLA035...
Adjustable from 1.5–35 bar

As a general rule, avoid working at the upper or lower limits of the operating range.

Select an XMLA035...

Converting Units of Pressure

| | psi | kg/cm ² | bar | atm | mm Hg (Torr) | mm H ₂ O | Pa |
|-------------------------|--------------------------|---------------------------|--------------------------|---------------------------|------------------------|---------------------|-----------------|
| 1 psi = | 1 | 0.07031 | 0.06895 | 0.06805 | 51.71 | 703.7 | 6895 |
| 1 kg/cm ² = | 14.22 | 1 | 0.98066 | 0.96784 | 735.55 | 10 000 | 98 066 |
| 1 bar = | 14.50 | 1.0197 | 1 | 0.98695 | 750.06 | 10 197 | 10 ⁵ |
| 1 atm = | 14.70 | 1.0333 | 1.0132 | 1 | 760.0 | 10 333 | 101 325 |
| 1 mm Hg = (Torr) | 0.01934 | 1.360 x 10 ⁻³ | 1.333 x 10 ⁻³ | 1.316 x 10 ⁻³ | 1 | 13.59 | 133.3 |
| 1 mm H ₂ O = | 1.421 x 10 ⁻³ | 10 ⁻⁴ | ~ 10 ⁻⁴ | ~ 10 ⁻⁴ | 0.07361 | 1 | ~ 9.80 |
| 1 Pa = | 1.45 x 10 ⁻⁴ | 1.0197 x 10 ⁻⁵ | 10 ⁻⁵ | 9.8695 x 10 ⁻⁶ | 7.5 x 10 ⁻³ | 0.10197 | 1 |

Example: 1 bar = 14.50 psi = 10⁵ Pa

Electromechanical pressure and vacuum switches

XML range

Operating curves: Fixed Differential, Detecting a Single Threshold

Adjustment range of the high point

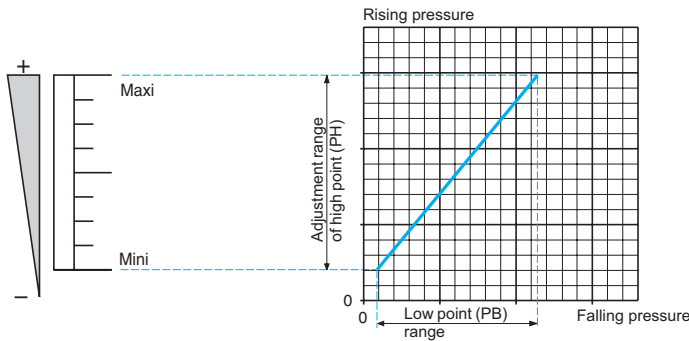

Defined by the difference between the minimum and maximum high point (PH) setting values.

For a high set point (PH), the lower point (PB) is fixed and cannot be adjusted.

For a low set point (PB), the higher point (PH) is fixed and cannot be adjusted.

Operating point on rising pressure (PH)

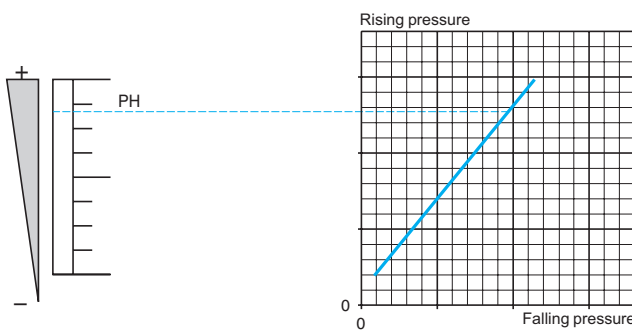

The upper pressure setting at which the pressure or vacuum switch actuates the contacts on rising pressure.

Adjustable throughout the range on rising pressure.

Operating point on falling pressure (PB)

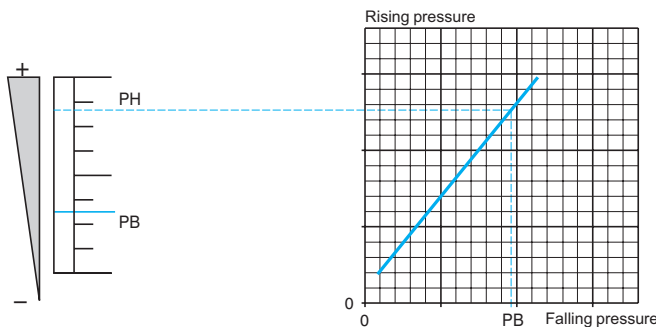

The pressure at which the switch contact changes state on falling pressure.

The lower point (PB) is not adjustable and is entirely dependent on the high point setting (PH) and the inherent differential of the switch.

Differential

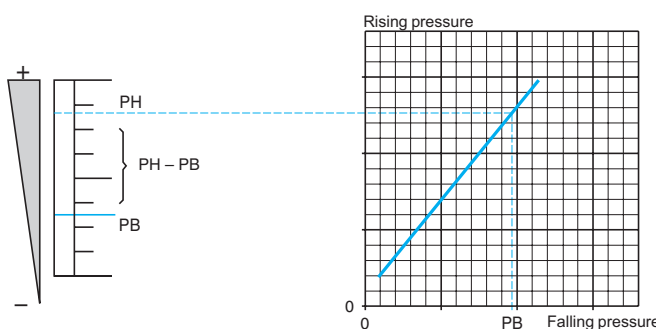

$PH - PB =$ inherent differential

The difference between the operating point on rising pressure (PH) and the operating point on falling pressure (PB).

This point is not adjustable, so the value of the differential is fixed.

It is the inherent differential of the switch (contact differential, friction, etc.).

Example

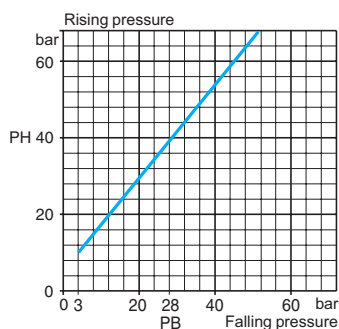

Operating point on rising pressure (PH) is 40 bar (set value at which the contact changes state on rising pressure).

The operating point on falling pressure (PB) is 28 bar (fixed value at which the contact returns to its original state).

Conclusion:
the differential is $40 - 28 = 12$ bar.

Electromechanical pressure and vacuum switches

XML range

Operating curves: Adjustable Differential, Regulating between Two Thresholds

Adjustment range of the high point

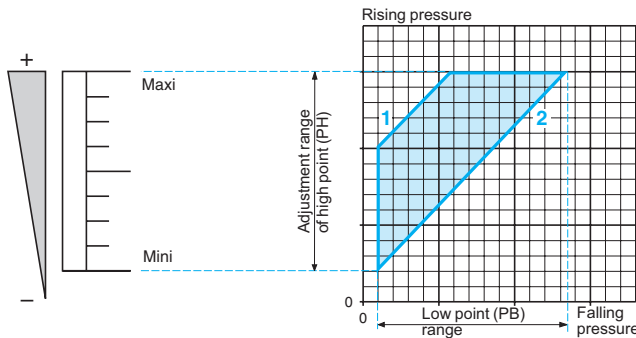

Defined by the difference between the minimum and maximum high point (PH) setting values.

Operating point on rising pressure (PH)

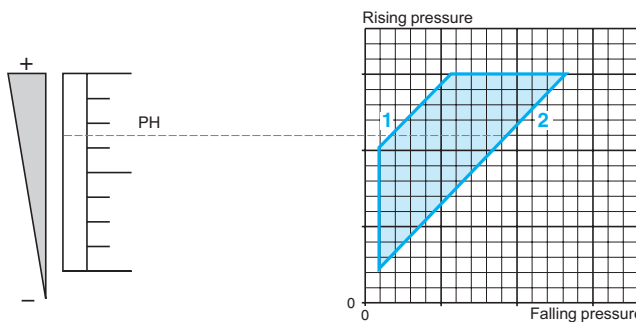

The upper pressure setting at which the pressure or vacuum switch actuates the contacts on rising pressure.
Adjustable throughout the range on rising pressure.

Operating point on falling pressure (PB)

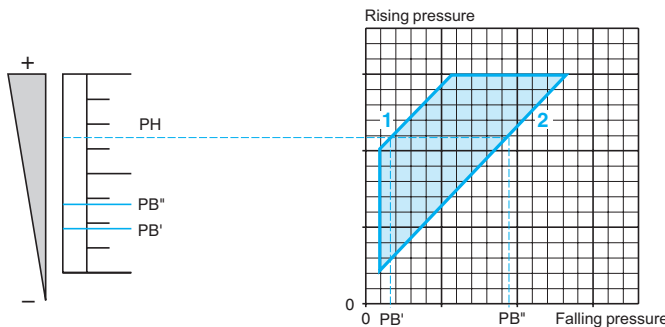

The pressure at which the switch contact changes state on falling pressure.
The adjustable differential enables the independent setting of the lower point (PB).

Differential

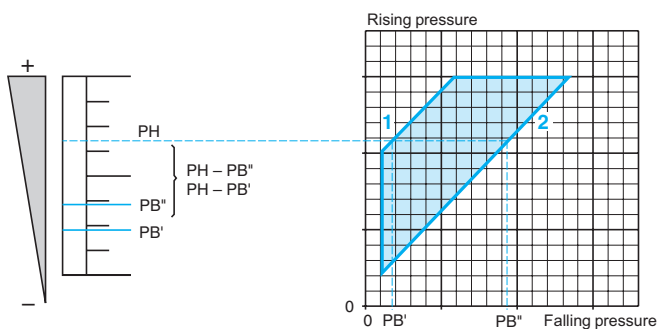

Low point < High point
 $PH - PB' =$ inherent differential
 $PH - PB'' =$ minimum differential
 The difference between the operating point on rising pressure (PH) and the operating point on falling pressure (PB).
Note: the low point can be set at any value between PB' and PB'' .

Example

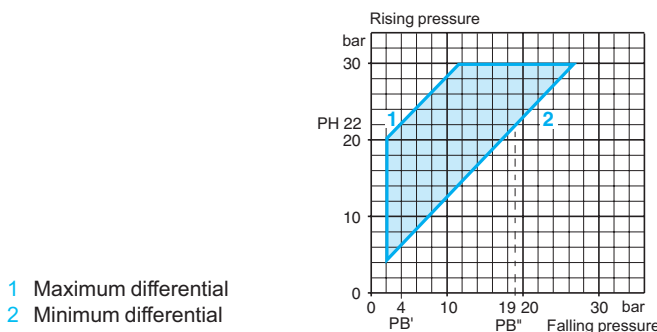

- 1 Maximum differential
- 2 Minimum differential

Operating point on rising pressure (PH) is 22 bar (set value at which the contact changes state on rising pressure).
 The operating point on falling pressure (PB) ranges from 4 and 19 bar (set value at which the contact returns to its original state).
 Conclusion:
 the maximum differential is $22 - 4 = 18$ bar,
 the minimum differential is $22 - 19 = 3$ bar.

Electromechanical pressure and vacuum switches

XML range

Operating curves: Dual-Stage, Fixed Differential, Detection at Each Threshold (switching on rising pressure)

Adjustment ranges of the operating points PH1 and PH2 on rising pressure

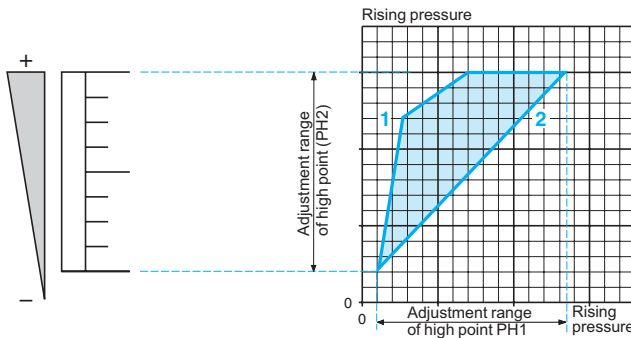

Defined by the difference between the minimum and maximum high point setting values of each stage (PH1 and PH2).

Operating point PH2 on rising pressure

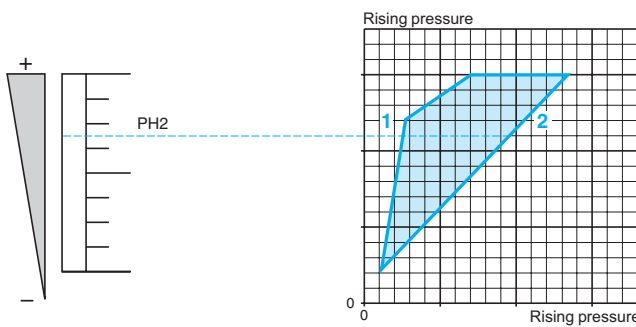

The upper pressure setting at which the pressure or vacuum switch actuates contact 2 on rising pressure. Adjustable throughout the range on rising pressure.

Operating point PH1 on rising pressure

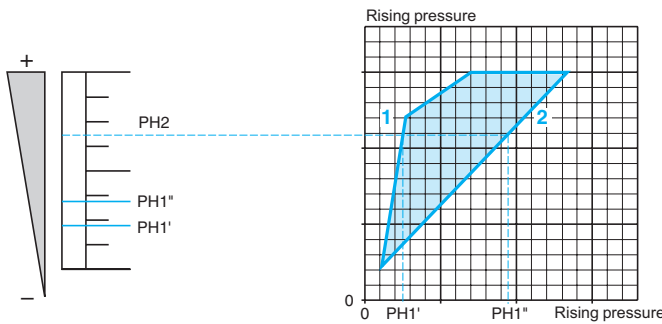

The upper pressure setting at which the pressure or vacuum switch actuates contact 1 on rising pressure.

Spread

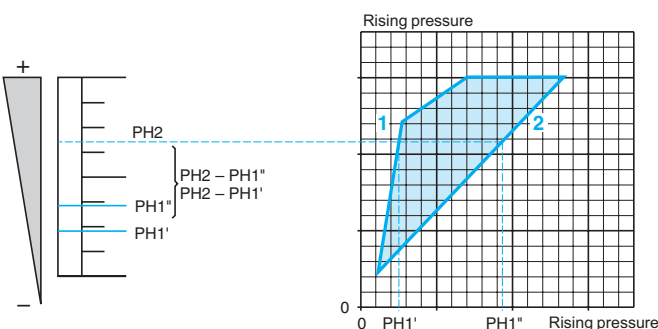

$PH1 < PH2$
 $PH2 - PH1' = \text{maximum spread}$
 $PH2 - PH1'' = \text{minimum spread}$

The difference between operating points PH2 and PH1 on rising pressure.

Note: operating point PH1 can be set at any value between PH1' and PH1''.

Example: Determining operating points on rising pressure for the two stages

- 1 Maximum spread
- 2 Minimum spread

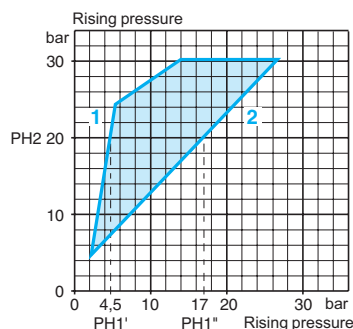

Second stage operating point on rising pressure (PH2) = 20 bar (set value at which contact 2 changes state on rising pressure). First stage operating point (PH1) can be set between 4.5 and 17 bar on rising pressure.

Conclusion:
 the maximum spread is:
 $20 - 4.5 = 15.5 \text{ bar}$,
 the minimum spread is:
 $20 - 17 = 3 \text{ bar}$.

Electromechanical pressure and vacuum switches

XML range

Operating curves: Dual-Stage, Fixed Differential, Detection at Each Threshold (switching on rising pressure)

Adjustment range of high point (PH1 or PH2)

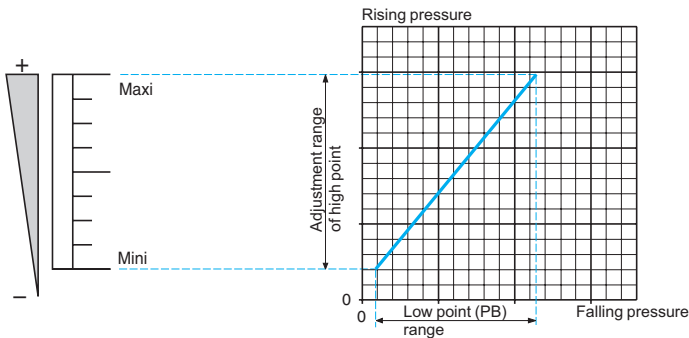

Defined by the difference between the minimum and maximum high point (PH1 or PH2) setting values for each stage.

For a high set point (PH1 or PH2), the lower point (PB1 or PB2) is fixed and cannot be adjusted.

For a low set point (PB1 or PB2), the higher point (PH1 or PH2) is fixed and cannot be adjusted.

Operating point on rising pressure (PH1 or PH2)

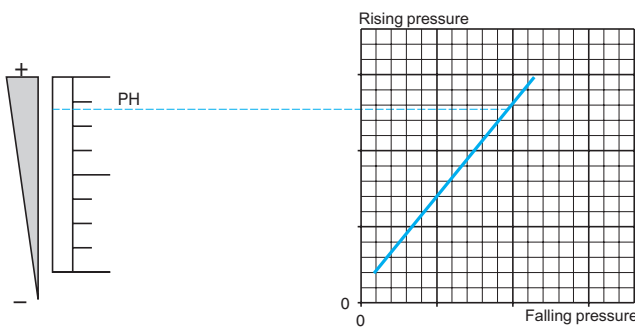

The upper pressure setting at which the pressure or vacuum switch actuates the contact, for each stage, on rising pressure. Adjustable throughout the range on rising pressure.

Operating point on falling pressure (PB1 or PB2)

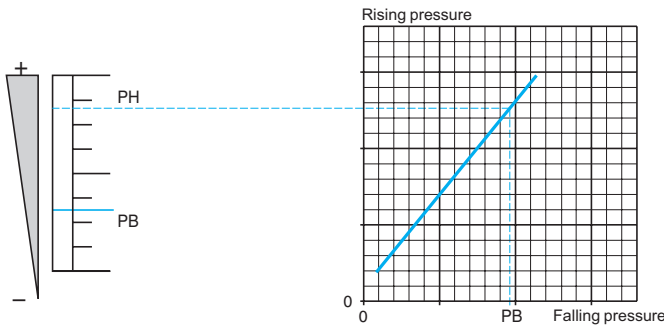

The pressure at which the switch contact changes state, for each stage, on falling pressure.

The lower point (PB) is not adjustable and is entirely dependent on the high point setting (PH) and the inherent differential of the switch.

Differential

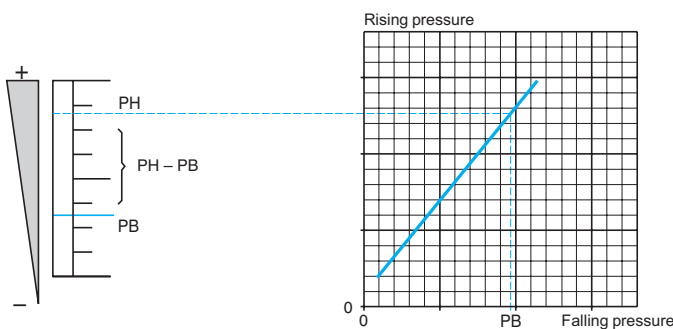

$PH - PB =$ inherent differential

The difference between the operating point on rising pressure (PH) and the operating point on falling pressure (PB), for each stage. This point is not adjustable, so the value of the differential is fixed. It is the inherent differential of the switch (contact differential, friction, etc.) for each of its two stages.

Example:
 stage 1 = segment EF
 stage 2 = segment GH

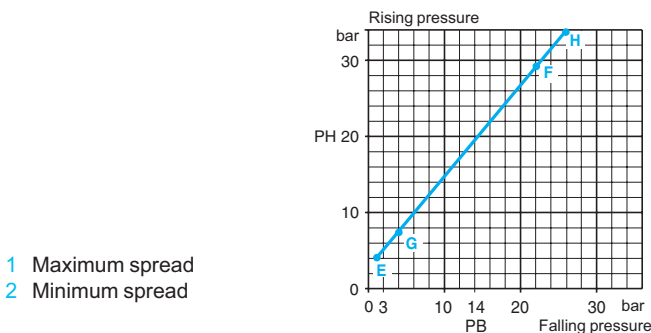

For stage 2 (segment GH):

Operating point on rising pressure (PH2) is 20 bar (set value at which contact 2 changes state on rising pressure). The operating point on falling pressure (PB2) is 14 bar (fixed value at which contact 2 returns to its original state).

Conclusion: for stage 2, the differential is: $20 - 14 = 6$ bar.

Repeat the same procedure for stage 1 (segment EF).

- 1 Maximum spread
- 2 Minimum spread

Electromechanical pressure and vacuum switches

XML range

Interpreting the reference for XML Devices

| Example: XMLA004A2S13 | | XML | A | 004 | A | 2 | S | 1 | 3 |
|--|--|---|-----|-----|---|---|---|---|-----|
| Designation | | Commercial reference | | | | | | | |
| XML Pressure Switch | | XML | | | | | | | |
| Type | Nonadjustable differential, single pole | A | | | | | | | |
| | Adjustable differential, single pole | B | | | | | | | |
| | Adjustable differential, double pole | C | | | | | | | |
| | Nonadjustable differential, double pole | D | | | | | | | |
| Operating range bar (psi) | 0 to 0.05 (0 to 0.725) | | L05 | | | | | | |
| | 0 to 0.35 (0 to 5.075) | | L35 | | | | | | |
| | 0 to 0.35 (0 to 5.075) Overpressure 0.30 (4.35) | | S35 | | | | | | |
| | -1 to -0.28 (-14.5 to -4.06) | | M01 | | | | | | |
| | -1 to -0.14 (-14.5 to -2.03) | | M02 | | | | | | |
| | -0.2 to -0.02 (-2.9 to -0.029) | | M03 | | | | | | |
| | -0.5 to 5 (-7.25 to 72.5) | | M05 | | | | | | |
| | 0 to 1 (0 to 14.5) | | 001 | | | | | | |
| | 0 to 2.5 (0 to 36.25) | | 002 | | | | | | |
| | 0 to 2.5 (0 to 36.25) Overpressure 0.30 (4.35) | | S02 | | | | | | |
| | 0 to 4 (0 to 58) | | 004 | | | | | | |
| | 0 to 4 (0 to 58) Overpressure 0.30 (4.35) | | S04 | | | | | | |
| | 0 to 10 (0 to 145) | | 010 | | | | | | |
| | 0 to 10 (0 to 145) Overpressure 0.30 (4.35) | | S10 | | | | | | |
| | 0 to 20 (0 to 290) | | 020 | | | | | | |
| | 0 to 20 (0 to 290) Overpressure 0.30 (4.35) | | S20 | | | | | | |
| | 0 to 35 (0 to 507.5) | | 035 | | | | | | |
| | 0 to 40 (0 to 580) | | 040 | | | | | | |
| | 0 to 70 (0 to 1015) | | 070 | | | | | | |
| | 0 to 160 (0 to 2320) | | 160 | | | | | | |
| 0 to 300 (0 to 4350) | | 300 | | | | | | | |
| 0 to 500 (0 to 7250) | | 500 | | | | | | | |
| Input fluid | Pressure switch diaphragm type | | | | | | | | |
| | Hydraulic oils, air, fresh, or sea water, 32-158 °F (0-70 °C) | | | | A | | | | |
| | Hydraulic oils, air, fresh, or sea water, 32-320 °F (0-160 °C) | | | | B | | | | |
| | Corrosive fluid | | | | C | | | | |
| | Viscous products | | | | P | | | | |
| | Hydraulic oils or air, 32-140 °F (0-60 °C) | | | | R | | | | |
| | Fresh or sea water, 32-320 °F (0-160 °C) | | | | S | | | | |
| | Vacuum switch diaphragm type | | | | | | | | |
| | Hydraulic oils, air, fresh or sea water, 32-158 °F (0-70 °C) | | | | V | | | | |
| | Hydraulic oils, air, fresh or sea water, 32-320 °F (0-160 °C) | | | | T | | | | |
| | Pressure switch piston type | | | | | | | | |
| | Hydraulic oils or air, 32-320 °F (0-160 °C) | | | | D | | | | |
| Fresh or sea water, 32-320 °F (0-160 °C) | | | | E | | | | | |
| Corrosive fluid, 32-320 °F (0-160 °C) | | | | N | | | | | |
| Display | Without | | | | | | 1 | | |
| | With | | | | | | 2 | | |
| Electrical connection | Threaded hole | | | | | | | S | |
| | EN 175301-803-A connector (ex DIN 43650) | | | | | | | C | |
| | M12 threaded connector (Micro Change type) | | | | | | | D | |
| Contact type | Dry contact | | | | | | | | 1 |
| Entry type | European | | | | | | | | |
| | Pressure | G 1/4 (BSP female) G 1-1/4 for viscous products (input fluid identifier = P) | | | | | | | 1 |
| | Electrical | Type 13 (Pg 13.5) | | | | | | | |
| | Pressure | G 1/4 (BSP female) G 1-1/4 for viscous products (input fluid identifier = P) | | | | | | | 2 |
| | Electrical | ISO M20 | | | | | | | |
| | U.S.A. | | | | | | | | |
| | Pressure | 1/4"-18 NPTF | | | | | | | 3 |
| | Electrical | 1/2"-14 NPT | | | | | | | |
| | Japan | | | | | | | | |
| | Pressure | PT 1/4 (JIS B0203) | | | | | | | |
| Electrical | 1/2 in. PF (JIS B0202) | | | | | | | | |
| Options | May indicate factory setting | | | | | | | | ... |

Size: -1 bar (-14.5 psi)
Fixed differential, for detection of a single threshold
1 C/O single-pole contact

XMLA vacuum switches **With setting scale**

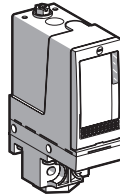

Adjustable range of operating point (PB)
 (falling pressure) -0.28 to -1 bar (-4.06 to -14.5 psi)

References

| | | |
|--|---|---|
| Fluids controlled For materials in contact with fluid, see page 62 | Hydraulic oils, fresh water, sea water, air, up to 158 °F (70 °C) | XMLAM01V2S11 |
| Pressure connection | | G 1/4-19 BSP |
| Electrical connection | Conduit/cable entry | Pg 13.5 |
| | Terminals | 1 x 0.2 to 2 x 2.5 mm ² (1 x 24 to 2 x 14 AWG) |
| Weight, lb (kg) | | 1.51 (0.685) |

Supplementary specifications (not shown under general specifications)

| | | |
|---|-----------------|---------------------------------|
| Inherent differential (add to PB to get PH) | At low setting | 0.24 bar ±0.05 (3.48 psi ±0.72) |
| | At high setting | 0.24 bar ±0.05 (3.48 psi ±0.72) |
| Maximum allowable pressure | Per cycle | 5 bar (72.5 psi) |
| | Accidental | 9 bar (130.5 psi) |
| Destruction pressure | | 18 bar (261 psi) |
| Vacuum switch style | | Diaphragm |

Operating curves **Connection**

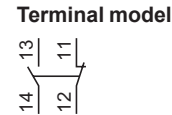
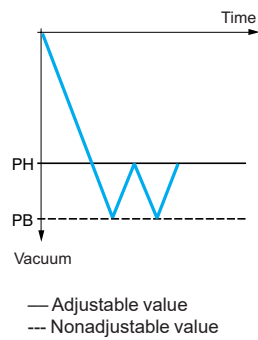
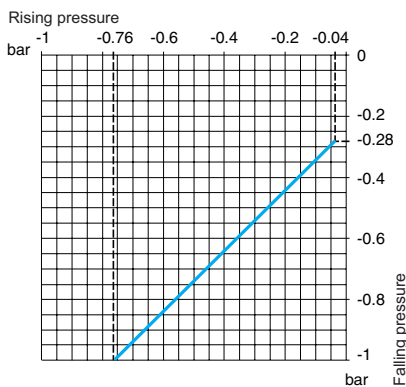

Other versions For switches with alternative tapped cable entries, please consult our Customer Care Center.

Size: -1 bar (-14.5 psi)
Adjustable differential, for regulation between two thresholds
1 C/O single-pole contact

XMLB vacuum switches **With setting scale**



Adjustable range of operating point (PB)
(falling pressure) -0.14 to -1 bar (-2.03 to -14.5 psi)

References

| | | | |
|--|--|---------------------|---|
| Fluids controlled Hydraulic oils, fresh water, sea water, air, For materials in contact with fluid, see page 62 up to 158 °F (70 °C) | XMLBM02V2S11 | XMLBM02V2S12 | XMLBM02V2C11 |
| Pressure connection | G 1/4-19 BSP | | |
| Electrical connection | Conduit/cable entry Pg 13.5 | ISO M20 | DIN 43650A, 4-pin male |
| | Terminals 1 x 0.2 to 2 x 2.5 mm ² (1 x 24 to 2 x 14 AWG) | | For suitable female connector, see page 57. |
| Weight, lb (kg) | 2.24 (1.015) | | 2.27 (1.030) |

Supplementary specifications (not shown under general specifications)

| | | |
|---|----------------------|---------------------------------|
| Possible differential (add to PB to get PH) | Min. at low setting | 0.13 bar ±0.02 (1.88 psi ±0.29) |
| | Min. at high setting | 0.13 bar ±0.02 (1.88 psi ±0.29) |
| | Max. at high setting | 0.8 bar (11.6 psi) |
| Maximum allowable pressure | Per cycle | 5 bar (72.5 psi) |
| | Accidental | 9 bar (130.5 psi) |
| Destruction pressure | | 18 bar (261 psi) |
| Vacuum switch style | | Diaphragm |

Operating curves

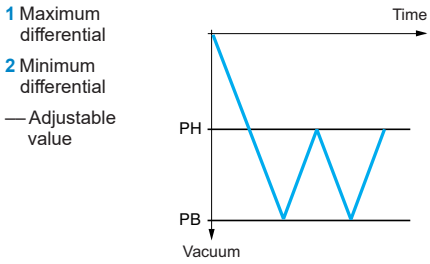
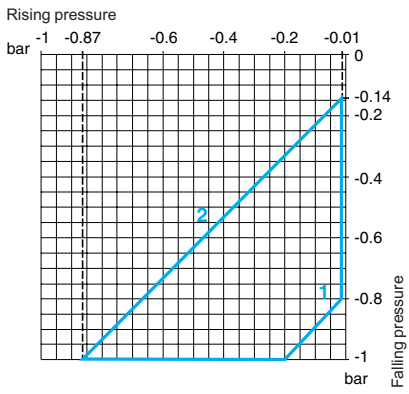

Connection

Terminal model



Connector model

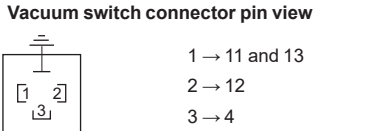

Other versions For switches with alternative tapped cable entries, please consult our Customer Care Center.

Size: -1 bar (-14.5 psi)
 Dual-stage, fixed differential, for detection at each threshold
 2 C/O single-pole contacts (one per stage)

XMLD vacuum switches Without setting scale

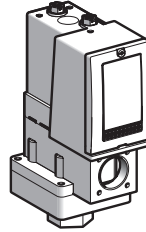

| | | |
|--|---------------------------------|--|
| Adjustable range of operating points (falling pressure) | 2nd stage operating point (PB2) | -0.12 to -1 bar (-1.74 to -14.5 psi) |
| | 1st stage operating point (PB1) | -0.10 to -0.98 bar (-1.45 to -14.21 psi) |
| Spread between the two stages (PB2—PB1) | | 0.02 to 0.88 bar (0.29 to 12.76 psi) |

References

| | | |
|--|---|---|
| Fluids controlled For materials in contact with fluid, see page 62 | Hydraulic oils, fresh water, sea water, air, up to 158 °F (70 °C) | XMLDM02V1S11 |
| Pressure connection | | G 1/4-19 |
| Electrical connection | Conduit/cable entry | Pg 13.5 |
| | Terminals | 1 x 0.2 to 2 x 2.5 mm ² (1 x 24 to 2 x 14 AWG) |
| Weight, lb (kg) | | 2.24 (1.015) |

Supplementary specifications (not shown under general specifications)

| | | |
|---|-----------------|---------------------------------|
| Inherent differential (add to PB1/PB2 to get PH1/PH2) | At low setting | 0.1 bar ±0.035 (1.45 psi ±0.51) |
| | At high setting | 0.1 bar ±0.02 (1.45 psi ±0.29) |
| Maximum allowable pressure | Per cycle | 5 bar (72.5 psi) |
| | Accidental | 9 bar (130.5 psi) |
| Destruction pressure | | 18 bar (261 psi) |
| Vacuum switch style | | Diaphragm |

Operating curves

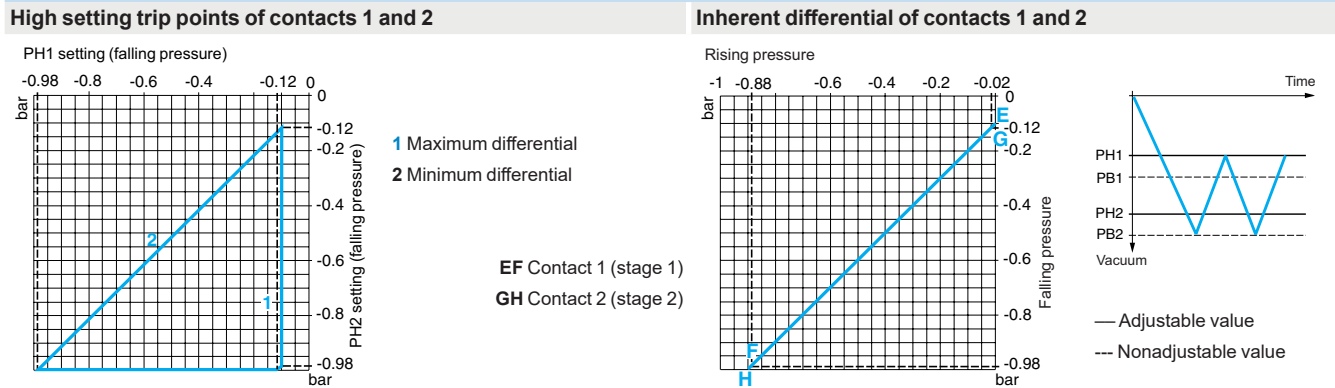

Connection: Terminal model

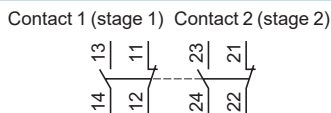

Other versions For switches with alternative tapped cable entries, please consult our Customer Care Center.

Size 5 bar (72.5 psi)
Adjustable differential, for regulation between two thresholds
1 C/O single-pole contact

XMLB vacu-pressure switches **With setting scale**

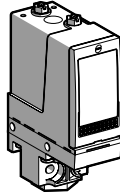

Adjustable range of operating point (PH) (rising pressure) -0.5 to 5 bar (-7.25 to 72.5 psi)

References

Fluids controlled Hydraulic oils, fresh water, sea water, air, up to 158 °F (70 °C) **XMLBM05A2S11**
 For materials in contact with fluid, see page 62

Pressure connection G 1/4-19

Electrical connection Conduit/cable entry Pg 13.5
 Terminals 1 x 0.2 to 2 x 2.5 mm² (1 x 24 to 2 x 14 AWG)

Weight, lb (kg) 1.51 (0.685)

Supplementary specifications (not shown under general specifications)

Possible differential (subtract from PH to get PB)
 Min. at low setting 0.5 bar ±0.05 (7.25 psi ±0.72)
 Min. at high setting 0.5 bar ±0.05 (7.25 psi ±0.72)
 Max. at high setting 6 bar (87 psi)

Maximum allowable pressure
 Per cycle 6.25 bar (90.62 psi)
 Accidental 11.25 bar (163.12 psi)

Destruction pressure 23 bar (333.5 psi)

Vacu-pressure switch style Diaphragm

Operating curves

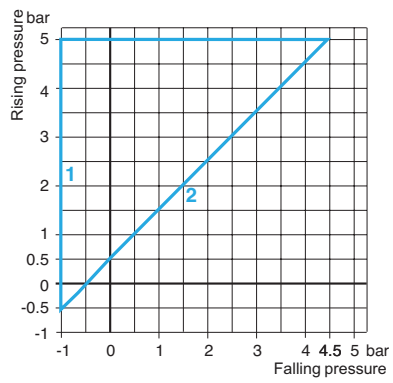

1 Maximum differential
 2 Minimum differential
 — Adjustable value

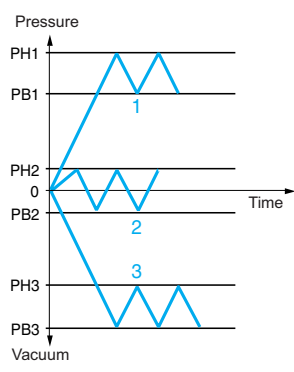

Connection

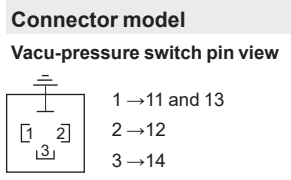
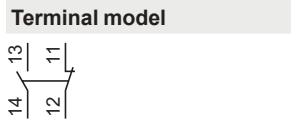

Other versions For switches with alternative tapped cable entries, please consult our Customer Care Center.

Size 350 mbar (5.07 psi)

Adjustable differential, for regulation between two thresholds

1 C/O single-pole contact

| XMLB pressure switches | With setting scale | With setting scale overpressure 30 bar (435 psi) |
|------------------------|--------------------|---|
|------------------------|--------------------|---|

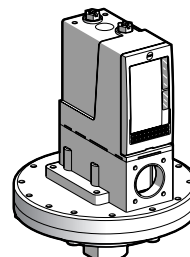
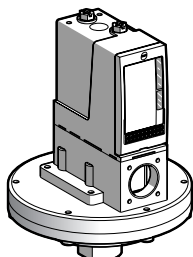

| | | |
|--|-----------------------------|--------------------------------|
| Adjustable range of operating point (PH) (rising pressure) | 45–350 mbar (0.65–5.07 psi) | 42–330 mbar (0.61–4.78 psi) |
|--|-----------------------------|--------------------------------|

References

| | | | | |
|--|---------------------|---------------------|---------------------|---------------------|
| Fluids controlled Hydraulic oils, air, up to 320 °F (160 °C) For materials in contact with fluid, see page 62 | XMLBL35R2S13 | XMLBL35R2S11 | XMLBS35R2S11 | XMLBS35R2S12 |
|--|---------------------|---------------------|---------------------|---------------------|

| | | | | |
|----------------------------|---------------|----------|--|--|
| Pressure connection | 1/4" -18 NPTF | G 1/4-19 | | |
|----------------------------|---------------|----------|--|--|

| | | | | | |
|------------------------------|---------------------|--|---------|--|---------|
| Electrical connection | Conduit/cable entry | 1/2" NPT | Pg 13.5 | Pg 13.5 | ISO M20 |
| | Terminals | 1 x 0.2 to 2 x 2.5 mm ² (1 x 24 to 2 x 14 AWG) | | 1 x 0.2 to 2 x 2.5 mm ² (1 x 24 to 2 x 14 AWG) | |

| | | |
|------------------------|--------------|--------------|
| Weight, lb (kg) | 5.68 (2.575) | 7.72 (3.500) |
|------------------------|--------------|--------------|

Supplementary specifications (not shown under general specifications)

| | | | |
|---|----------------------|--|--|
| Possible differential (subtract from PH to get PB) | Min. at low setting | 42 mbar –8, +3 (0.60 psi –0.12, +0.04) | 33 mbar –8, +3 (0.48 psi –0.12, +0.04) |
| | Min. at high setting | 50 mbar ±8 (0.72 psi ±0.11) | 58 mbar ±8 (0.84 psi ±0.11) |
| | Max. at high setting | 300 mbar (4.35 psi) | 250 mbar (3.62 psi) |

| | | | |
|-----------------------------------|------------|----------------------|-----------------------|
| Maximum allowable pressure | Per cycle | 1.25 bar (18.12 psi) | 30 bar (435 psi) |
| | Accidental | 2.25 bar (32.62 psi) | 37.5 bar (543.75 psi) |

| | | |
|-----------------------------|---------------------|-----------------------|
| Destruction pressure | 4.5 bar (65.25 psi) | 67.5 bar (978.75 psi) |
|-----------------------------|---------------------|-----------------------|

| | |
|------------------------------|-----------|
| Pressure switch style | Diaphragm |
|------------------------------|-----------|

Operating curves

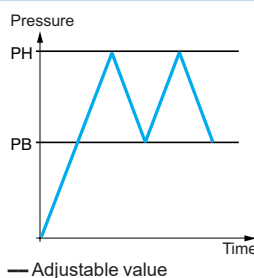
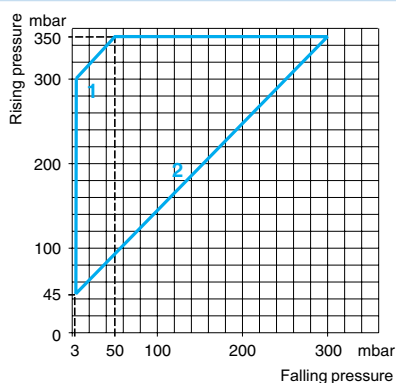

- 1 Maximum differential
- 2 Minimum differential

Connection

Terminal model



Other versions

For switches with alternative tapped cable entries, please consult our Customer Care Center.

Size 350 mbar (5.07 psi)
Adjustable differential, for regulation between two thresholds
2 C/O single-pole contacts

XMLC pressure switches **With setting scale**
overpressure 30 bar (435 psi)

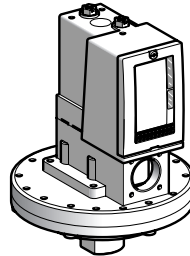

Adjustable range of operating point (PH)
(rising pressure) 42–330 mbar (0.61–4.78 psi)

References

| | | | | |
|--|--|---|---------------------|---------------------|
| Fluids controlled For materials in contact with fluid, see page 62 | Hydraulic oils, air, up to 320 °F (160 °C) | XMLCS35R2S13 | XMLCS35R2S11 | XMLCS35R2S12 |
| Pressure connection | | 1/4"-18 NPTF | G 1/4-19 | |
| Electrical connection | Conduit/cable entry | 1/2" NPT | Pg 13.5 | ISO M20 |
| | Terminals | 1 x 0.2 to 2 x 2.5 mm ² (1 x 24 to 2 x 14 AWG) | | |
| Weight, lb (kg) | 7.72 (3.500) | | | |

Supplementary specifications (not shown under general specifications)

| | | |
|--|----------------------|------------------------------|
| Possible differential (subtract from PH to get PB) | Min. at low setting | 40 mbar ±20 (0.58 psi ±0.29) |
| | Min. at high setting | 88 mbar ±20 (1.27 psi ±0.29) |
| | Max. at high setting | 230 mbar (3.33 psi) |
| Maximum allowable pressure | Per cycle | 30 bar (435 psi) |
| | Accidental | 37.5 bar (543.75 psi) |
| Destruction pressure | | 67.5 bar (978.75 psi) |
| Pressure switch style | | Diaphragm |

Operating curves **Connection**

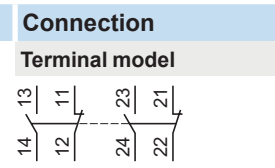
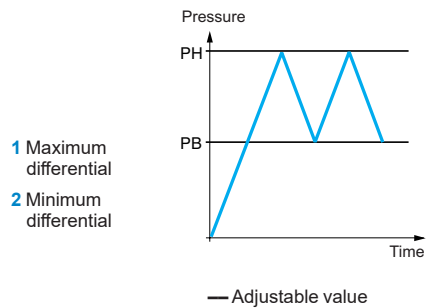
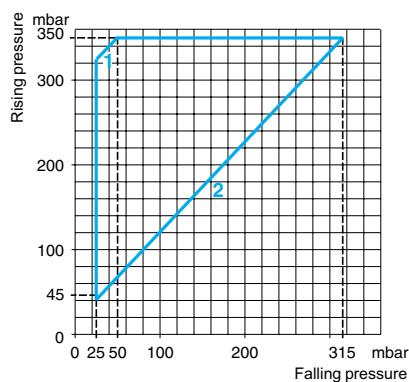

Other versions For switches with alternative tapped cable entries, please consult our Customer Care Center.

Size 1 bar (14.5 psi)
Fixed differential, for detection of a single threshold
1 C/O single-pole contact

XMLA pressure switches | **With setting scale**

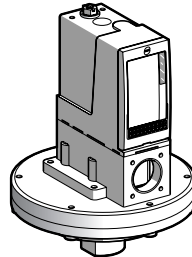

Adjustable range of operating point (PH)
(rising pressure) | 0.03–1 bar (0.435–14.5 psi)

References

| | | |
|--|---|---------------------|
| Fluids controlled For materials in contact with fluid, see page 62 | Hydraulic oils, air, up to 320 °F (160 °C) | XMLA001R2S11 |
| | Fresh water, sea water, corrosive fluids, up to 320 °F (160 °C) | XMLA001S2S11 |

Pressure connection | G 1/4-19

Electrical connection | Conduit/cable entry Pg 13.5
Terminals 1 x 0.2 to 2 x 2.5 mm² (1 x 24 to 2 x 14 AWG)

Weight, lb (kg) | 5.63 (2.555)

Supplementary specifications (not shown under general specifications)

Inherent differential | At low setting 0.02 bar ±0.01 (0.29 psi ±0.14)
(subtract from PH to get PB) | At high setting 0.04 bar ±0.01 (0.58 psi ±0.14)

Maximum allowable pressure | Per cycle 1.25 bar (18.12 psi)
Accidental 2.25 bar (32.62 psi)

Destruction pressure | 4.5 bar (65.25 psi)

Pressure switch style | Diaphragm

Operating curves | **Connection**

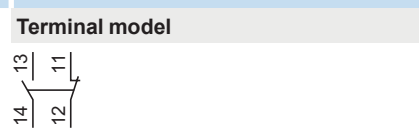
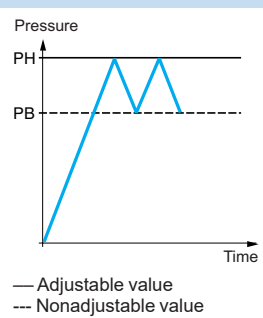
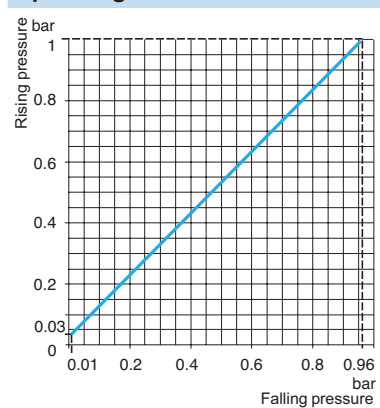

Other versions | For switches with alternative tapped cable entries, please consult our Customer Care Center.

Size 1 bar (14.5 psi)
Adjustable differential, for regulation between two thresholds
1 C/O single-pole contact

XMLB pressure switches **With setting scale**

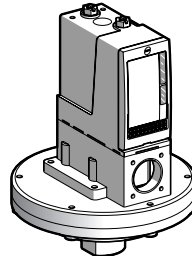

| | | |
|--|---|---|
| Adjustable range of operating point (PH) (rising pressure) | 0.05–1 bar (0.72–14.5 psi) | |
| Electrical connection | Terminals | |
| References | | |
| Fluids controlled For materials in contact with fluid, see page 62 | Hydraulic oils, air, up to 320 °F (160 °C) | XMLB001R2S11 |
| | Fresh water, sea water, corrosive fluids, up to 320 °F (160 °C) | — XMLB001S2S12 |
| Pressure connection | G 1/4-19 | |
| Electrical connection | Conduit/cable entry | Pg 13.5 ISO M20 |
| | Terminals | 1 x 0.2 to 2 x 2.5 mm ² (1 x 24 to 2 x 14 AWG) |
| Weight, lb (kg) | 5.68 (2.575) | |
| Supplementary specifications (not shown under general specifications) | | |
| Possible differential (subtract from PH to get PB) | Min. at low setting | 0.04 bar ±10 (0.58 psi ±0.14) |
| | Min. at high setting | 0.06 bar ±20 (0.87 psi ±0.29) |
| | Max. at high setting | 0.75 bar (10.87 psi) |
| Maximum allowable pressure | Per cycle | 1.25 bar (18.12 psi) |
| | Accidental | 2.25 bar (32.62 psi) |
| Destruction pressure | 4.5 bar (65.25 psi) | |
| Pressure switch style | Diaphragm | |

Operating curves **Connection**

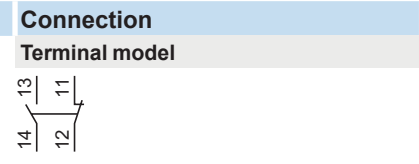
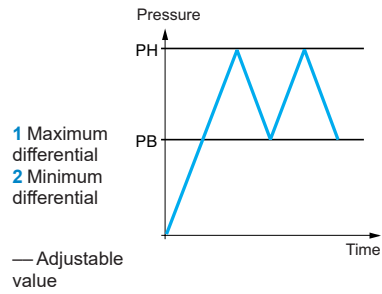
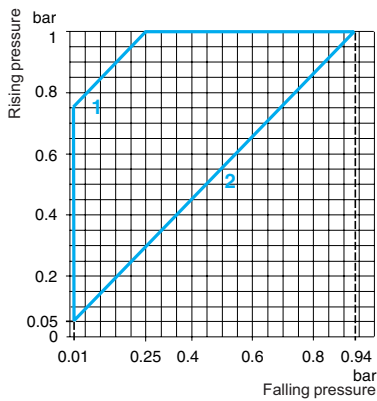

Other versions For switches with alternative tapped cable entries, please consult our Customer Care Center.

Size 2.5 bar (36.25 psi)
Fixed differential, for detection of a single threshold
1 C/O single-pole contact

XMLA pressure switches **With setting scale**

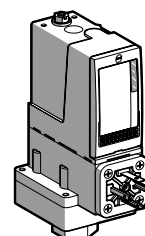
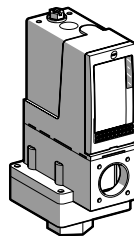

Adjustable range of operating point (PH)
(rising pressure) 0.15–2.5 bar (2.17–36.25 psi)

References

| | | | | |
|---|---|---|---------------------|---|
| Fluids controlled For materials in contact with fluid, see page 62. | Hydraulic oils, fresh water, sea water, air, up to 158 °F (70 °C) | XMLA002A2S11 | XMLA002A2S12 | XMLA002A2C11 |
| | Corrosive fluids, up to 320 °F (160 °C) | XMLA002C2S11 | – | – |
| Pressure connection | | G 1/4-19 | | |
| Electrical connection | Conduit/cable entry | Pg 13.5 | ISO M20 | DIN 43650A, 4-pin male |
| | Terminals | 1 x 0.2 to 2 x 2.5 mm ² (1 x 24 to 2 x 14 AWG) | | For suitable female connector, see page 57. |
| Weight, lb (kg) | | 2.19 (0.995) | | 2.23 (1.010) |

Supplementary specifications (not shown under general specifications)

| | | |
|--|-----------------|---------------------------------|
| Inherent differential (subtract from PH to get PB) | At low setting | 0.13 bar ±0.03 (1.88 psi ±0.43) |
| | At high setting | 0.13 bar ±0.03 (1.88 psi ±0.43) |
| Maximum allowable Pressure | Per cycle | 5 bar (72.5 psi) |
| | Accidental | 9 bar (130.5 psi) |
| Destruction pressure | | 18 bar (261 psi) |
| Pressure switch style | | Diaphragm |

Operating curves **Connection**

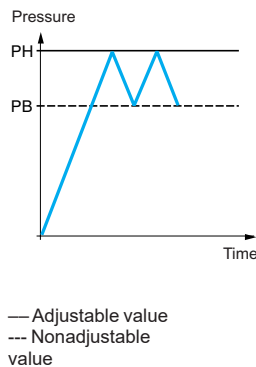
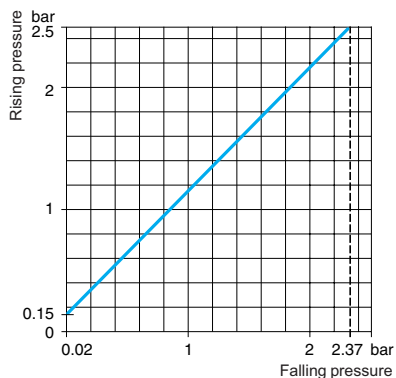

Terminal model



Connector model

Pressure switch connector pin view

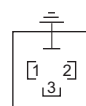

- 1 → 11 and 13
- 2 → 12
- 3 → 14

Other versions For switches with alternative tapped cable entries, please consult our Customer Care Center.

Size 2.5 bar (36.25 psi)
Adjustable differential, for regulation between two thresholds
1 C/O single-pole contact

| XMLB pressure switches | With setting scale | With setting scale overpressure 30 bar (435 psi) |
|------------------------|--------------------|---|
|------------------------|--------------------|---|

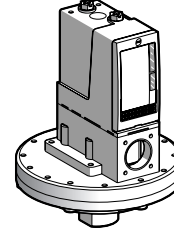
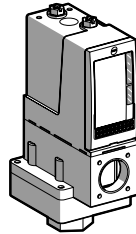

| | | | |
|---|------------------------------|--|--|
| Adjustable range of operating point (PH) (rising pressure) | 0.3–2.5 bar (4.35–36.25 psi) | | |
|---|------------------------------|--|--|

References

| | | | | |
|---|--|---------------------|---------------------|---------------------|
| Fluids controlled For materials in contact with fluid, see page 62. | Hydraulic oils, fresh water, sea water, air, up to 158 °F (70 °C) | XMLB002A2S11 | XMLB002A2S12 | — |
| | Hydraulic oils, fresh water, sea water, air, up to 320 °F (160 °C) | XMLB002B2S11 | — | — |
| | Hydraulic oils, fresh water, air, up to 320 °F (160 °C) | — | — | XMLBS02B2S11 |

| | | | | |
|------------------------------|---------------------|---|---|---|
| Pressure connection | G 1/4-19 | | | |
| Electrical connection | Conduit/cable entry | Pg 13.5 | ISO M20 | Pg 13.5 |
| | Terminals | 1 x 0.2 – 2 x 2.5 mm ² (1 x 24 to 2 x 14 AWG) | 1 x 0.2 – 2 x 2.5 mm ² (1 x 24 to 2 x 14 AWG) | 1 x 0.2 – 2 x 2.5 mm ² (1 x 24 to 2 x 14 AWG) |
| Weight, lb (kg) | 2.24 (1.015) | 2.24 (1.015) | 7.72 (3.500) | |

Supplementary specifications (not shown under general specifications)

| | | | |
|--|----------------------|---|--|
| Possible differential (subtract from PH to get PB) | Min. at low setting | 0.16 bar, –0.8 mbar, +1.1 mbar (2.32 psi, –0.01, +0.02) | 0.1 bar –0.8 mbar, +1.1 mbar (1.45 psi –0.01, +0.02) |
| | Min. at high setting | 0.21 bar ±1.4 mbar (3.04 psi ±0.02) | 0.22 bar ±1.4 mbar (3.19 psi ±0.02) |
| | Max. at high setting | 1.75 bar (25.37 psi) | 1.45 bar (21 psi) |
| Maximum allowable pressure | Per cycle | 5 bar (72.5 psi) | 30 bar (435 psi) |
| | Accidental | 9 bar (130.5 psi) | 37.5 bar (543.75 psi) |
| Destruction pressure | 18 bar (261 psi) | | 67.5 bar (978.75 psi) |
| Pressure switch style | Diaphragm | | |

Operating curves

The graph plots Rising pressure (bar) on the y-axis (0 to 2.5) against Falling pressure (bar) on the x-axis (0 to 2.29). A diagonal line represents the pressure path. Two horizontal dashed lines indicate adjustable values. The vertical distance between these lines is labeled '1' (Maximum differential). The vertical distance from the lower line to the diagonal is labeled '2' (Minimum differential).

The graph plots Pressure on the y-axis against Time on the x-axis. It shows a sawtooth wave representing pressure fluctuations. Two horizontal lines are shown: PH (Pressure High) and PB (Pressure Below). The wave crosses PH and then PB. A legend indicates that the horizontal lines represent 'Adjustable value'.

Connection

Terminal model

The terminal model diagram shows a 4-pin connector with pins numbered 11, 12, 13, and 14. Pins 11 and 12 are grouped together, and pins 13 and 14 are grouped together.

Other versions For switches with alternative tapped cable entries, please consult our Customer Care Center.

Size 2.5 bar (36.25 psi)
Adjustable differential, for regulation between two thresholds
2 C/O single-pole contacts

| XMLC pressure switches | With setting scale | With setting scale overpressure 30 bar (435 psi) |
|------------------------|--------------------|--|
|------------------------|--------------------|--|

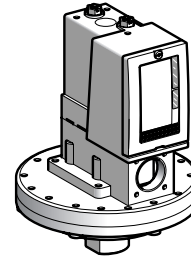
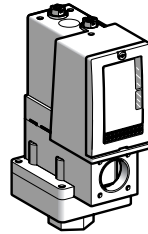

Adjustable range of operating point (PH)
(rising pressure) | 0.3–2.5 bar (4.35–36.25 psi)

| References | | | | | | |
|--|--|---|---------------------|---------------------|---------------------|---------------------|
| Fluids controlled Hydraulic oils, fresh water, air, up to 320 °F (160 °C) For materials in contact with fluid, see page 62. | Hydraulic oils, fresh water, air, up to 320 °F (160 °C) | — | — | XMLCS02B2S13 | XMLCS02B2S11 | XMLCS02B2S12 |
| | Hydraulic oils, fresh water, sea water, air, up to 320 °F (160 °C) | XMLC002B2S11 | XMLC002B2S12 | — | — | — |
| Pressure connection | G 1/4-19 | | 1/4"-18 NPTF | G 1/4-19 | | |
| Electrical connection | Conduit/cable entry | Pg 13.5 | ISO M20 | 1/2" NPT | Pg 13.5 | ISO M20 |
| | Terminals | 1 x 0.2 to 2 x 2.5 mm ² (1 x 24 to 2 x 14 AWG) | | | | |
| Weight, lb (kg) | 2.19 (0.995) | | 7.72 (3.500) | | | |

| Supplementary specifications (not shown under general specifications) | | | |
|---|----------------------|---------------------------------|---------------------------------|
| Possible differential (subtract from PH to get PB) | Min. at low setting | 0.13 bar ±0.02 (1.89 psi ±0.29) | 0.1 bar ±0.02 (1.45 psi ±0.29) |
| | Min. at high setting | 0.17 bar ±0.03 (2.47 psi ±0.43) | 0.18 bar ±0.03 (2.61 psi ±0.43) |
| | Max. at high setting | 2 bar (29 psi) | 1.25 bar (18.12 psi) |
| Maximum allowable pressure | Per cycle | 5 bar (72.5 psi) | 30 bar (435 psi) |
| | Accidental | 9 bar (130.5 psi) | 37.5 bar (543.75 psi) |
| Destruction pressure | 18 bar (261 psi) | | 67.5 bar (978.75 psi) |
| Pressure switch style | Diaphragm | | |

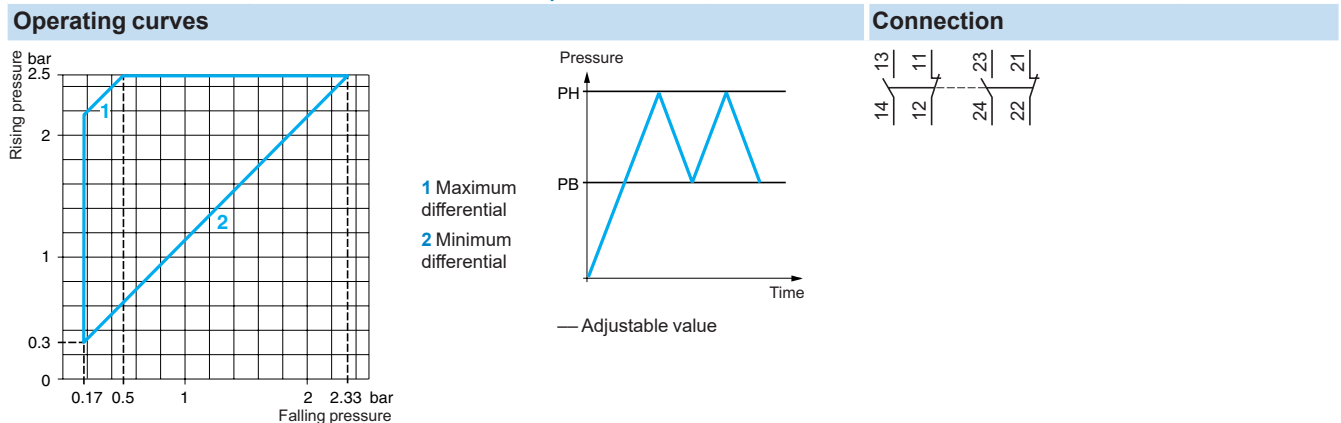

Other versions For switches with alternative tapped cable entries, please consult our Customer Care Center.

Size 4 bar (58 psi)
Fixed differential, for detection of a single threshold
1 C/O single-pole contact

XMLA pressure switches **With setting scale**

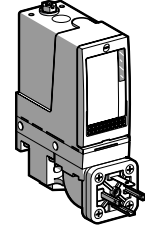
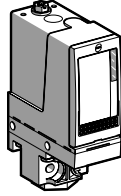

Adjustable range of operating point (PH)
(rising pressure) 0.4–4 bar (5.8–58 psi)

References

| | | | | | |
|---|--|---------------------|---------------------|---------------------|---------------------|
| Fluids controlled For materials in contact with fluid, see page 62. | Hydraulic oils, fresh water, sea water, air, up to 158 °F (70 °C) | XMLA004A2S13 | XMLA004A2S11 | XMLA004A2S12 | XMLA004A2C11 |
| | Hydraulic oils, fresh water, sea water, air, up to 320 °F (160 °C) | — | XMLA004B2S11 | — | — |
| | Corrosive fluids, up to 320 °F (160 °C) | — | XMLA004C2S11 | — | — |

Pressure connection 1/4"-18 NPTF G 1/4-19

Electrical connection
Conduit/cable entry 1/2" NPT Pg 13.5 ISO M20 DIN 43650A, 4-pin male
Terminals 1 x 0.2 to 2 x 2.5 mm² (1 x 24 to 2 x 14 AWG) For suitable female connector, see page 57.

Weight, lb (kg) 1.51 (0.685) 1.58 (0.715)

Supplementary specifications (not shown under general specifications)

Inherent differential (subtract from PH to get PB)
At low setting 0.35 bar ±0.03 (5.07 psi ±0.43)
At high setting 0.35 bar ±0.03 (5.07 psi ±0.43)

Maximum allowable pressure
Per cycle 5 bar (72.5 psi)
Accidental 9 bar (130.5 psi)

Destruction pressure 18 bar (261 psi)

Pressure switch style Diaphragm

Operation curves

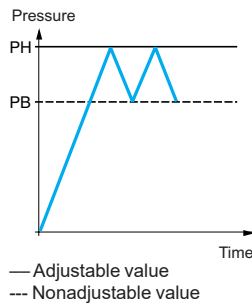
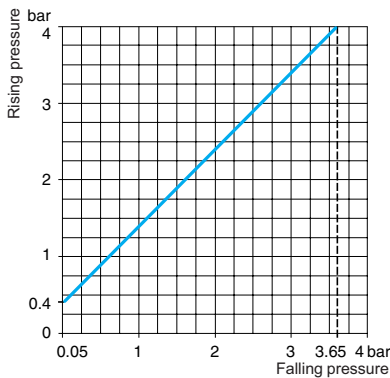

Connection

Terminal model



Connector model

Pressure switch connector pin view

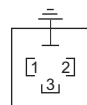

1 → 11 and 13
2 → 12
3 → 14

Other versions For switches with alternative tapped cable entries, please consult our Customer Care Center.

Size 4 bar (58 psi)
Adjustable differential, for regulation between 2 thresholds
1 C/O single-pole contact

| | | |
|-------------------------------|---------------------------|---|
| XMLB pressure switches | With setting scale | With setting scale overpressure 30 bar (435 psi) |
|-------------------------------|---------------------------|---|

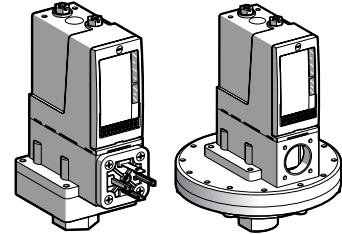
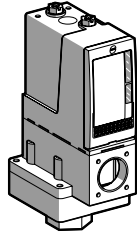

Adjustable range of operating point (PH)
(rising pressure) 0.25–4 bar (3.62–58 psi)

| References | | XMLB004A2S13 | XMLB004A2S11 | XMLB004A2S12 | XMLB004A2C11 | | |
|--|--|--------------|--------------|--------------|--------------|--------------|--------------|
| Fluids controlled Hydraulic oils, fresh water, sea water, air, up to 158 °F (70 °C) For materials in contact with fluid, see page 62. | Hydraulic oils, fresh water, sea water, air, up to 320 °F (160 °C) | | XMLB004B2S11 | | | | |
| | Hydraulic oils, freshwater, air, up to 320 °F (160 °C) | | | | | XMLBS04B2S11 | XMLBS04B2S12 |

| | | | | | | | |
|------------------------------|---------------------|--|----------|---------|---|--|---------|
| Pressure connection | | 1/4"-18 NPTF | G 1/4-19 | | | | |
| Electrical connection | Conduit/cable entry | 1/2" NPT | Pg 13.5 | ISO M20 | DIN 43650A, 4-pin male | Pg 13.5 | ISO M20 |
| | Terminals | 1 x 0.2 to 2 x 2.5 mm ² (1 x 24 to 2 x 14 AWG) | | | For suitable female connector, see page 57. | 1 x 0.2 to 2 x 2.5 mm ² (1 x 24 to 2 x 14 AWG) | |
| Weight, lb (kg) | | 2.24 (1.015) | | | 2.27 (1.030) | 7.72 (3.500) | |

| Supplementary specifications (not shown under general specifications) | | | |
|---|----------------------|---|---|
| Possible differential (subtract from PH to get PB) | Min. at low setting | 0.2 bar ±0.01 (2.9 psi ±0.14) | 0.15 bar ±0.01 (2.18 psi ±0.14) |
| | Min. at high setting | 0.25 bar, -0.03, +0.05 (3.62 psi, -0.43, +0.72) | 0.34 bar, -0.03, +0.05 (4.93 psi, -0.43, +0.72) |
| | Max. at high setting | 2.4 bar (34.8 psi) | 2.46 bar (35.67 psi) |
| Maximum allowable pressure | Per cycle | 5 bar (72.5 psi) | 30 bar (435 psi) |
| | Accidental | 9 bar (130.5 psi) | 37.5 bar (543.75 psi) |
| Destruction pressure | | 18 bar (261 psi) | 67.5 bar (978.75 psi) |
| Pressure switch style | | Diaphragm | |

Operating curves

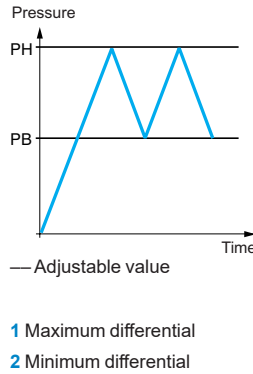
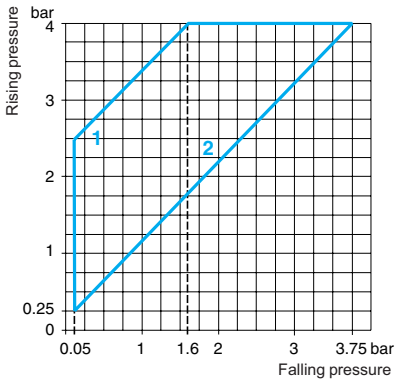

Connection

Terminal model



Connector model

Pressure switch connector pin view

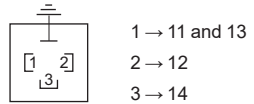

Other versions For switches with alternative tapped cable entries, please consult our Customer Care Center.

Size 4 bar (58 psi)
Adjustable differential, for regulation between two thresholds
2 C/O single-pole contacts

| XMLC pressure switches | With setting scale | With setting scale overpressure 30 bar (435 psi) |
|------------------------|--------------------|---|
|------------------------|--------------------|---|

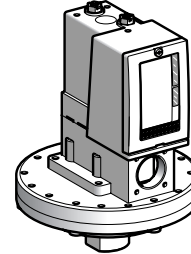
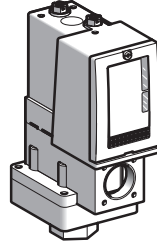

Adjustable range of operating point (PH)
(rising pressure) 0.3–4 bar (4.35–58 psi)

| References | | | | | |
|---|--|---|---------------------|---------------------|---------------------|
| Fluids controlled For materials in contact with fluid, see page 62. | Hydraulic oils, fresh water, air, up to 320 °F (160 °C) | — | — | XMLCS04B2S11 | XMLCS04B2S12 |
| | Hydraulic oils, fresh water, sea water, air, up to 320 °F (160 °C) | XMLC004B2S11 | XMLC004B2S12 | — | — |
| Pressure connection | G 1/4-19 | | | | |
| Electrical connection | Conduit/cable entry | Pg 13.5 | ISO M20 | Pg 13.5 | ISO M20 |
| | Terminals | 1 x 0.2 to 2 x 2.5 mm ² (1 x 24 to 2 x 14 AWG) | | | |
| Weight, lb (kg) | 1.51 (0.685) | | 7.72 (3.500) | | |

| Supplementary specifications (not shown under general specifications) | | | | | |
|---|----------------------|---------------------------------|-----------------------|---------------------------------|--|
| Possible differential (subtract from PH to get PB) | Min. at low setting | 0.15 bar ±0.02 (2.18 psi ±0.29) | | 0.1 bar ±0.02 (1.45 psi ±0.29) | |
| | Min. at high setting | 0.17 bar ±0.02 (2.47 psi ±0.29) | | 0.25 bar ±0.02 (3.62 psi ±0.29) | |
| | Max. at high setting | 2.5 bar (36.25 psi) | | 2.20 bar (31.9 psi) | |
| Maximum allowable pressure | Per cycle | 5 bar (72.5 psi) | | 30 bar (435 psi) | |
| | Accidental | 9 bar (130.5 psi) | | 37.5 bar (543.75 psi) | |
| Destruction pressure | 18 bar (261 psi) | | 67.5 bar (978.75 psi) | | |
| Pressure switch style | Diaphragm | | | | |

| Operating curves | | Connection |
|--|---------------------------|---------------------------|
| <p>1 Maximum differential 2 Minimum differential</p> | <p>— Adjustable value</p> | Terminal model |

Other versions For switches with alternative tapped cable entries, please consult our Customer Care Center.

Size 10 bar (145 psi)
Fixed differential, for detection of a single threshold
1 C/O single-pole contact

XMLA pressure switches **With setting scale**

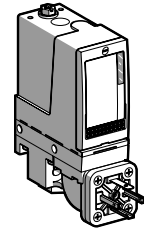
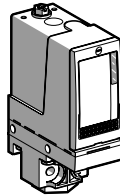

Adjustable range of operating point (PH)
(rising pressure) | 0.6–10 bar (8.7–145 psi)

| References | | | | | |
|---|--|---|---------------------|---------------------|---|
| Fluids controlled For materials in contact with fluid, see page 62. | Hydraulic oils, fresh water, sea water, air, up to 158 °F (70 °C) | XMLA010A2S13 | XMLA010A2S11 | XMLA010A2S12 | XMLA010A2C11 |
| | Hydraulic oils, fresh water, sea water, air, up to 320 °F (160 °C) | — | XMLA010B2S11 | — | — |
| | Corrosive fluids, up to 320 °F (160 °C) | — | XMLA010C2S11 | — | — |
| Pressure connection | | 1/4"-18 NPTF | G 1/4-19 | | |
| Electrical connection | Conduit/cable entry | 1/2" NPT | Pg 13.5 | ISO M20 | DIN 43650A, 4-pin male |
| | Terminals | 1 x 0.2 to 2 x 2.5 mm ² (1 x 24 to 2 x 14 AWG) | | | For suitable female connector, see page 57. |
| Weight, lb (kg) | | 1.51 (0.685) | | | 1.58 (0.715) |

Supplementary specifications (not shown under general specifications)

| | | |
|--|-----------------|--------------------------------|
| Inherent differential (subtract from PH to get PB) | At low setting | 0.5 bar ±0.05 (7.25 psi ±0.72) |
| | At high setting | 0.5 bar ±0.05 (7.25 psi ±0.72) |
| Maximum allowable pressure | Per cycle | 12.5 bar (181.25 psi) |
| | Accidental | 22.5 bar (326.25 psi) |
| Destruction pressure | | 45 bar (652.5 psi) |
| Pressure switch style | | Diaphragm |

Operating curves **Connection**

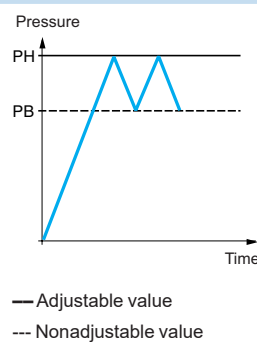
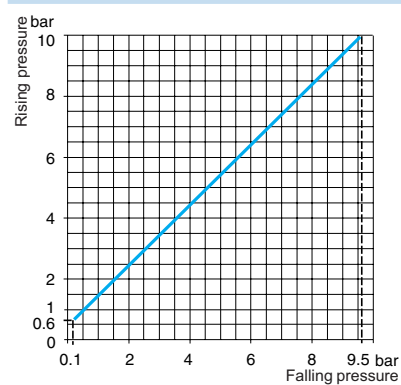

Terminal model



Connector model

Pressure switch connector pin view

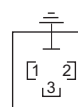

- 1 → 11 and 13
- 2 → 12
- 3 → 14

Other versions For switches with alternative tapped cable entries, please consult our Customer Care Center.

Size 10 bar (145 psi)
Adjustable differential, for regulation between two thresholds
1 C/O single-pole contact

XMLB pressure switches **With setting scale**

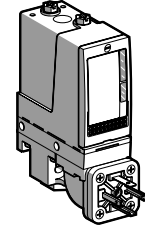
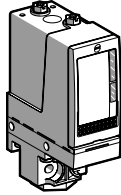

Adjustable range of operating point (PH)
(rising pressure) 0.7–10 bar (10.15–145 psi)

| References | | | | | |
|---|---|--|---------------------|---------------------|---|
| Fluids controlled For materials in contact with fluid, see page 62. | Hydraulic oils, fresh water, sea water, air, up to 158 °F (70 °C) | XMLB010A2S13 | XMLB010A2S11 | XMLB010A2S12 | XMLB010A2C11 |
| | Hydraulic oils, fresh water, air, up to 320 °F (160 °C) | — | XMLB010B2S11 | — | — |
| | Corrosive fluids, up to 320 °F (160 °C) | — | XMLB010C2S11 | — | XMLB010C2C11 |
| Pressure connection | | 1/4"-18 NPTF | G 1/4-19 | | |
| Electrical connection | Conduit/cable entry | 1/2" NPT | Pg 13.5 | ISO M20 | DIN 43650A, 4-pin male |
| | Terminals | 1 x 0.2 to 2 x 2.5 mm ² (1 x 24 to 2 x 14 AWG) | | | For suitable female connector, see page 57. |
| Weight, lb (kg) | | 1.55 (0.705) | | | 1.62 (0.735) |

| Supplementary specifications (not shown under general specifications) | | |
|---|----------------------|---|
| Possible differential (subtract from PH to get PB) | Min. at low setting | 0.57 bar ±0.05 (8.26 psi ±0.72). |
| | Min. at high setting | 0.85 bar, -0.1, +0.15 (12.32 psi, -1.45, +2.17) |
| | Max. at high setting | 7.5 bar (108.75 psi) |
| Maximum allowable pressure | Per cycle | 12.5 bar (181.25 psi) |
| | Accidental | 22.5 bar (326.25 psi) |
| Destruction pressure | | 45 bar (652.5 psi) |
| Pressure switch style | | Diaphragm |

Operating curves

Connection

Terminal model

Connector model

Pressure switch connector pin view

Other versions For switches with alternative tapped cable entries, please consult our Customer Care Center.

Size 10 bar (145 psi)
Adjustable differential, for regulation between two thresholds
2 C/O single-pole contacts

| | | |
|-------------------------------|---------------------------|---|
| XMLC pressure switches | With setting scale | With setting scale overpressure 30 bar (435 psi) |
|-------------------------------|---------------------------|---|

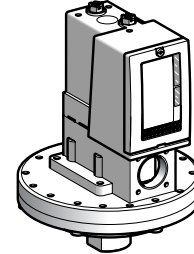
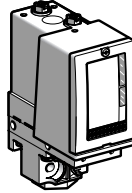

| | |
|--|----------------------------|
| Adjustable range of operating point (PH) (rising pressure) | 0.7–10 bar (10.15–145 psi) |
|--|----------------------------|

References

| | | | |
|---|--|---------------------|---------------------|
| Fluids controlled For materials in contact with fluid, see page 62. | Hydraulic oils, fresh water, air, up to 158 °F (70 °C) | — | XMLCS10A2S11 |
| | Hydraulic oils, fresh water, sea water, air, up to 320 °F (160 °C) | XMLC010B2S11 | — |
| | Corrosive fluids, up to 320 °F (160 °C) | XMLC010C2S11 | — |

| | |
|----------------------------|----------|
| Pressure connection | G 1/4-19 |
|----------------------------|----------|

| | | | |
|------------------------------|---------------------|---|---------|
| Electrical connection | Conduit/cable entry | Pg 13.5 | Pg 13.5 |
| | Terminals | 1 x 0.2 to 2 x 2.5 mm ² (1 x 24 to 2 x 14 AWG) | |

| | | |
|------------------------|--------------|--------------|
| Weight, lb (kg) | 1.51 (0.685) | 7.72 (3.500) |
|------------------------|--------------|--------------|

Supplementary specifications (not shown under general specifications)

| | | | |
|--|----------------------|----------------------------------|---------------------------------|
| Possible differential (subtract from PH to get PB) | Min. at low setting | 0.45 bar ±0.05 (6.53 psi ±0.72) | 0.25 bar ±0.05 (3.62 psi ±0.72) |
| | Min. at high setting | 0.70 bar ±0.01 (10.15 psi ±1.45) | 0.65 bar ±0.01 (9.42 psi ±1.45) |
| | Max. at high setting | 8 bar (116 psi) | 5.6 bar (81.2 psi) |
| Maximum allowable pressure | Per cycle | 12.5 bar (181.25 psi) | 30 bar (435 psi) |
| | Accidental | 22.5 bar (326.25 psi) | 37.5 bar (543.75 psi) |
| Destruction pressure | | 45 bar (652.5 psi) | 67.5 bar (978.75 psi) |
| Pressure switch style | Diaphragm | | |

Operating curves

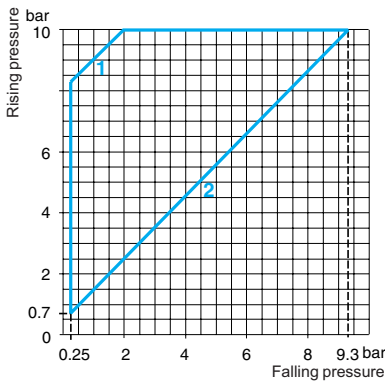

1 Maximum differential
2 Minimum differential

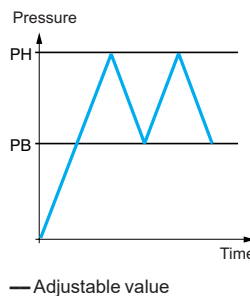

Connection

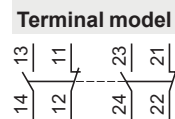

Other versions For switches with alternative tapped cable entries, please consult our Customer Care Center.

Size 10 bar (145 psi)
Dual-stage, fixed differential, for detection at each threshold
2 C/O single-pole contacts (one per stage)

XMLD pressure switches Without setting scale

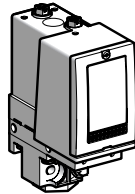

| | | |
|---|---------------------------------|---------------------------------|
| Adjustable range of each operating point (rising pressure) | 2nd stage operating point (PH2) | 1.2–10 bar (17.4–145 psi) |
| | 1st stage operating point (PH1) | 0.52–9.32 bar (7.54–135.14 psi) |
| Spread between the two stages (PH2–PH1) | | 0.68–5.8 bar (9.86–84.1 psi) |

References

| | | |
|---|--|---|
| Fluids controlled For materials in contact with fluid, see page 62. | Hydraulic oils, fresh water, sea water, air, up to 320 °F (160 °C) | XMLD010B1S11 |
| Pressure connection | | G 1/4-19 |
| Electrical connection | Conduit/cable entry | Pg 13.5 |
| | Terminals | 1 x 0.2 to 2 x 2.5 mm ² (1 x 24 to 2 x 14 AWG) |
| Weight, lb (kg) | | 1.55 (0.705) |

Supplementary specifications (not shown under general specifications)

| | | |
|--|-----------------|---------------------------------|
| Inherent differential (subtract from PH1/PH2 to get PB1/PB2) | At low setting | 0.45 bar ±0.05 (6.53 psi ±0.72) |
| | At high setting | 0.6 bar, ±0.1 (8.7 psi ±1.45) |
| Maximum allowable pressure | Per cycle | 12.5 bar (181.25 psi) |
| | Accidental | 22.5 bar (326.25 psi) |
| Destruction pressure | | 45 bar (652.5 psi) |
| Pressure switch style | | Diaphragm |

Operating curves

High setting trip points of contacts 1 and 2 **Inherent differential of contacts 1 and 2**

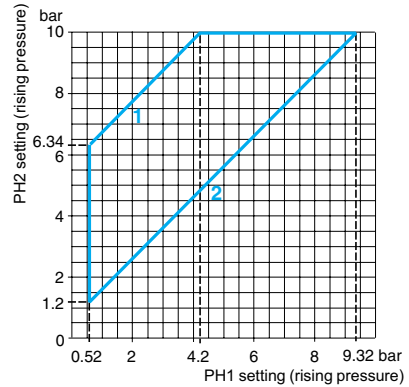

1 Maximum differential
2 Minimum differential

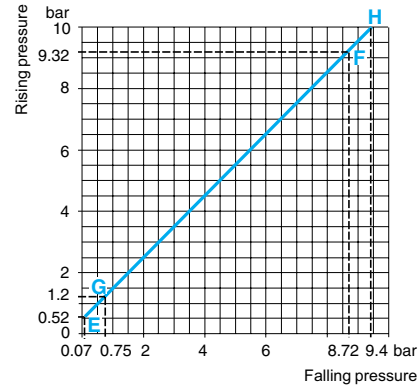

EF Contact 1 (stage 1)
GH Contact 2 (stage 2)

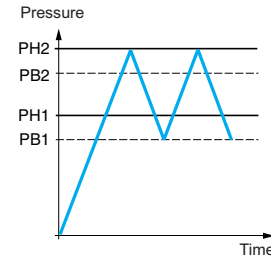

— Adjustable value
--- Nonadjustable value

Connection
Terminal model

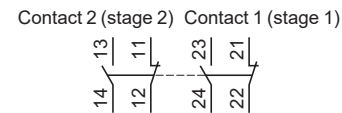

Other versions For switches with alternative tapped cable entries, please consult our Customer Care Center.

Size 20 bar (290 psi)
Fixed differential, for detection of a single threshold
1 C/O single-pole contact

XMLA pressure switches **With setting scale**

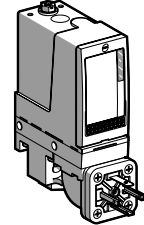
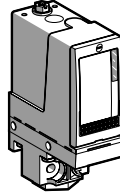

Adjustable range of operating point (PH)
(rising pressure) | 1–20 bar (14.5–290 psi)

References

| | | | | | |
|---|--|---------------------|---------------------|---------------------|---------------------|
| Fluids controlled For materials in contact with fluid, see page 62. | Hydraulic oils, fresh water, sea water, air, up to 158 °F (70 °C) | XMLA020A2S13 | XMLA020A2S11 | XMLA020A2S12 | XMLA020A2C11 |
| | Hydraulic oils, fresh water, sea water, air, up to 320 °F (160 °C) | — | XMLA020B2S11 | XMLA020B2S12 | XMLA020B2C11 |
| | Corrosive fluids, up to 320 °F (160 °C) | — | XMLA020C2S11 | — | — |

Pressure connection | 1/4"-18 NPTF | G 1/4-19

Electrical connection | Conduit/cable entry | 1/2" NPT | Pg 13.5 | ISO M20 | DIN 43650A, 4-pin male

Terminals | 1 x 0.2 to 2 x 2.5 mm² (1 x 24 to 2 x 14 AWG) | For suitable female connector, see page 57.

Weight, lb (kg) | 1.51 (0.685) | 1.58 (0.715)

Supplementary specifications (not shown under general specifications)

Inherent differential | At low setting | 0.4 bar ±0.2 (5.8 psi ±2.9)

(subtract from PH to get PB) | At high setting | 1 bar ±0.1 (14.5 psi ±1.45)

Maximum allowable pressure | Per cycle | 25 bar (362.5 psi)

Accidental | 45 bar (652.5 psi)

Destruction pressure | 90 bar (1305 psi)

Pressure switch style | Diaphragm

Operating curves **Connection**

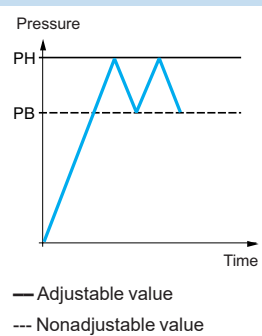
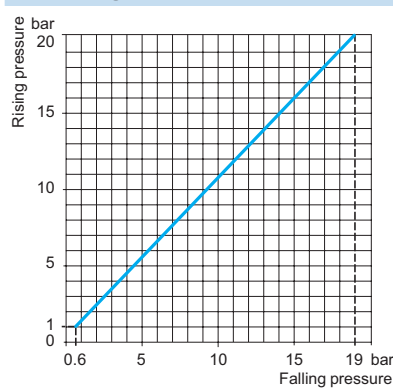

Terminal model

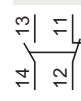

Connector model

Pressure switch connector pin view

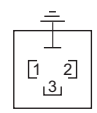

- 1 → 11 and 13
- 2 → 12
- 3 → 14

Other versions | For switches with alternative tapped cable entries, please consult our Customer Care Center.

Size 20 bar (290 psi)
Adjustable differential, for regulation between two thresholds
1 C/O single-pole contact

XMLB pressure switches **With setting scale**

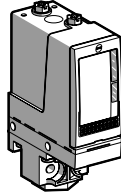

Adjustable range of operating point (PH)
(rising pressure) 1.3–20 bar (18.9–290 psi)

References

| | | | | |
|--|---|--|---------------------|---------------------|
| Fluids controlled For materials in contact with fluid, see page 62 | Hydraulic oils, fresh water, sea water, air, up to 158 °F (70 °C) | XMLB020A2S13 | XMLB020A2S11 | XMLB020A2S12 |
| | Hydraulic oils, fresh water, air, up to 320 °F (160 °C) | — | XMLB020B2S11 | — |
| | Corrosive fluids, up to 320 °F (160 °C) | — | XMLB020C2S11 | XMLB020C2S12 |
| Pressure connection | | 1/4"-18 NPTF | G 1/4-19 | |
| Electrical connection | Conduit/cable entry | 1/2" NPT | Pg 13.5 | ISO M20 |
| | Terminals | 1 x 0.2 to 2 x 2.5 mm ² (1 x 24 to 2 x 14 AWG) | | |
| Weight, lb (kg) | | 1.55 (0.705) | | |

Supplementary specifications (not shown under general specifications)

| | | |
|--|----------------------|---------------------------------|
| Possible differential (subtract from PH to get PB) | Min. at low setting | 1 bar ±0.25 (14.5 psi ±3.63) |
| | Min. at high setting | 1.6 bar ±0.25 (23.20 psi ±3.63) |
| | Max. at high setting | 11 bar (159.5 psi) |
| Maximum allowable pressure | Per cycle | 25 bar (362.5 psi) |
| | Accidental | 45 bar (652.5 psi) |
| Destruction pressure | | 90 bar (1305 psi) |
| Pressure switch style | | Diaphragm |

Operating curves **Connection**

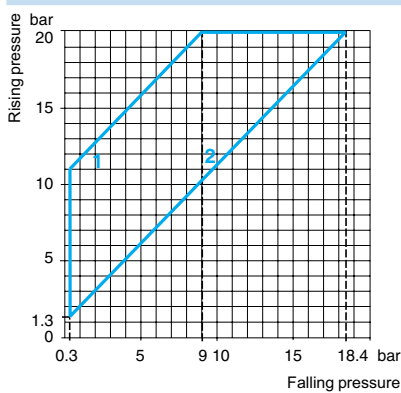

1 Maximum differential
2 Minimum differential

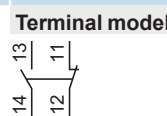
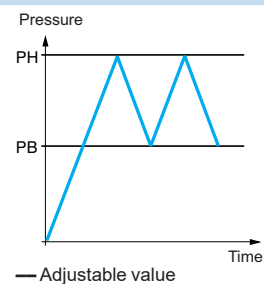

Other versions For switches with alternative tapped cable entries, please consult our Customer Care Center.

Size 20 bar (290 psi)
Adjustable differential, for regulation between two thresholds
2 C/O single-pole contacts

XMLC pressure switches **With setting scale**

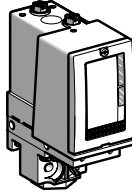

Adjustable range of operating point (PH)
(rising pressure) 1.3–20 bar (18.85–290 psi)

References

| | | | |
|--|--|---|---------------------|
| Fluids controlled For materials in contact with fluid, see page 62 | Hydraulic oils, fresh water, sea water, air, up to 320 °F (160 °C) | XMLC020B2S11 | XMLC020B2S12 |
| Pressure connection | | G 1/4-19 | |
| Electrical connection | Conduit/cable entry | Pg 13.5 | ISO M20 |
| | Terminals | 1 x 0.2 to 2 x 2.5 mm ² (1 x 24 to 2 x 14 AWG) | |
| Weight, lb (kg) | | 1.51 (0.685) | |

Supplementary specifications (not shown under general specifications)

| | | |
|--|----------------------|-------------------------------|
| Possible differential (subtract from PH to get PB) | Min. at low setting | 0.7 bar ±0.2 (10.15 psi ±2.9) |
| | Min. at high setting | 1 bar ±0.2 (14.5 psi ±2.9) |
| | Max. at high setting | 11 bar (159.5 psi) |
| Maximum allowable pressure | Per cycle | 25 bar (362.5 psi) |
| | Accidental | 45 bar (652.5 psi) |
| Destruction pressure | | 90 bar (1305 psi) |
| Pressure switch style | | Diaphragm |

Operating curves **Connection**

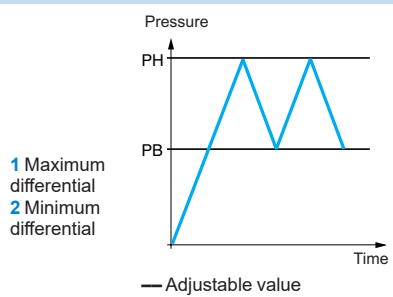
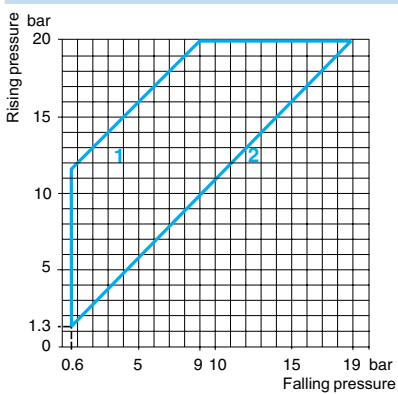

1 Maximum differential
2 Minimum differential

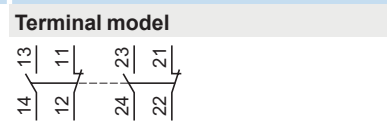

Other versions For switches with alternative tapped cable entries, please consult our Customer Care Center.

Size 20 bar (290 psi)
Dual-stage, fixed differential, for detection at each threshold
2 C/O single-pole contacts (one per stage)

XMLD pressure switches Without setting scale

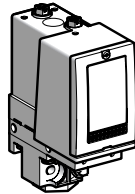

| | | |
|---|---------------------------------|----------------------------------|
| Adjustable range of each operating point (rising pressure) | 2nd stage operating point (PH2) | 2.14-20 bar (31.03-290 psi) |
| | 1st stage operating point (PH1) | 0.9-18.76 bar (13.05-272.02 psi) |
| Spread between the two stages (PH2-PH1) | | 1.24-9.55 bar (17.98-138.48 psi) |

References

| | | |
|---|---|---|
| Fluids controlled For materials in contact with fluid, see page 62. | Corrosive fluids, up to 320 °F (160 °C) | XMLD020C1S12 |
| Pressure connection | | G 1/4-19 |
| Electrical connection | Conduit/cable entry | ISO M20 |
| | Terminals | 1 x 0.2 to 2 x 2.5 mm ² (1 x 24 to 2 x 14 AWG) |
| Weight, lb (kg) | | 1.55 (0.705) |

Supplementary specifications (not shown under general specifications)

| | | |
|--|-----------------|---------------------------------|
| Inherent differential (subtract from PH1/PH2 to get PB1/PB2) | At low setting | 0.7 bar ±1.05 (10.15 psi ±2.18) |
| | At high setting | 1.3 bar, ±0.3 (18.85 psi ±4.35) |
| Maximum allowable pressure | Per cycle | 25 bar (362.5 psi) |
| | Accidental | 45 bar (652.5 psi) |
| Destruction pressure | | 90 bar (1305 psi) |
| Pressure switch style | | Diaphragm |

Operating curves

High setting trip points of contacts 1 and 2 **Inherent differential of contacts 1 and 2**

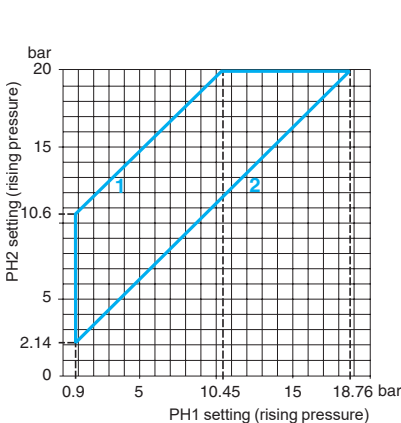

1 Maximum differential
2 Minimum differential

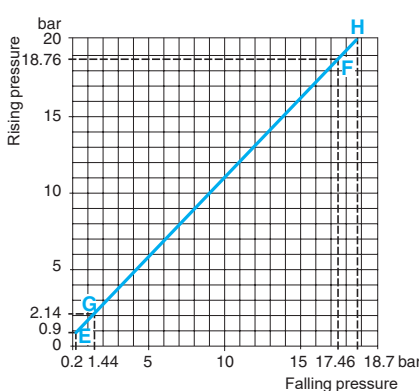

EF Contact 1 (stage 1)
GH Contact 2 (stage 2)

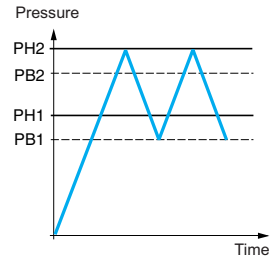

Connection
Terminal model

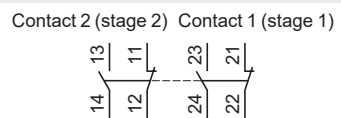

Other versions For switches with alternative tapped cable entries, please consult our Customer Care Center.

Size 35 bar (507.5 psi)

Fixed differential, for detection of a single threshold

1 C/O single-pole contact

XMLA pressure switches **With setting scale**

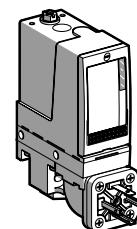
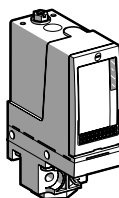

| | |
|--|------------------------------|
| Adjustable range of operating point (PH) (rising pressure) | 1.5-35 bar (21.75-507.5 psi) |
|--|------------------------------|

References

| | | | | |
|---|--|---------------------|---------------------|---------------------|
| Fluids controlled For materials in contact with fluid, see page 62. | Hydraulic oils, fresh water, sea water, air, up to 158 °F (70 °C) | XMLA035A2S11 | XMLA035A2S12 | XMLA035A2C11 |
| | Hydraulic oils, fresh water, sea water, air, up to 320 °F (160 °C) | XMLA035B2S11 | — | XMLA035B2C11 |
| | Corrosive fluids, up to 320 °F (160 °C) | — | — | XMLA035C2C11 |

| | |
|----------------------------|----------|
| Pressure connection | G 1/4-19 |
|----------------------------|----------|

| | | | | |
|------------------------------|---------------------|---|---------|---|
| Electrical connection | Conduit/cable entry | Pg 13.5 | ISO M20 | DIN 43650A, 4-pin male |
| | Terminals | 1 x 0.2 to 2 x 2.5 mm ² (1 x 24 to 2 x 14 AWG) | | For suitable female connector, see page 57. |

| | | |
|------------------------|--------------|--------------|
| Weight, lb (kg) | 1.53 (0.695) | 1.60 (0.725) |
|------------------------|--------------|--------------|

Supplementary specifications (not shown under general specifications)

| | | |
|--|-----------------|----------------------------------|
| Inherent differential (subtract from PH to get PB) | At low setting | 1.25 bar ±0.25 (18.12 psi ±3.62) |
| | At high setting | 1.25 bar ±0.25 (18.12 psi ±3.62) |

| | | |
|-----------------------------------|------------|--------------------|
| Maximum allowable Pressure | Per cycle | 45 bar (652.5 psi) |
| | Accidental | 80 bar (1160 psi) |

| | |
|-----------------------------|--------------------|
| Destruction pressure | 160 bar (2320 psi) |
|-----------------------------|--------------------|

| | |
|------------------------------|-----------|
| Pressure switch style | Diaphragm |
|------------------------------|-----------|

Operating curves **Connection**

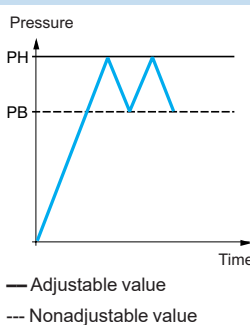
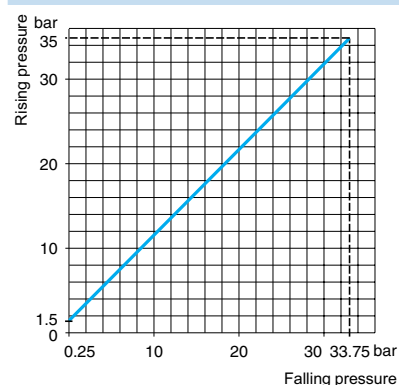

Terminal model



Connector model

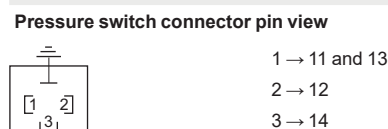

Other versions For switches with alternative tapped cable entries, please consult our Customer Care Center.

Size 35 bar (507.5 psi)
Adjustable differential, for regulation between two thresholds
1 C/O single-pole contact

XMLB pressure switches **With setting scale**

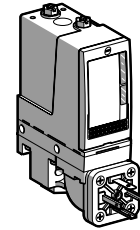
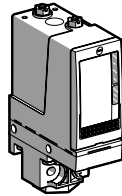

Adjustable range of operating point (PH)
(rising pressure) 3.5–35 bar (50.75–507.5 psi)

| References | | | |
|---|--|---|---|
| Fluids controlled For materials in contact with fluid, see page 62. | Hydraulic oils, fresh water, sea water, air, up to 158 °F (70 °C) | XMLB035A2S11 | XMLB035A2C11 |
| | Hydraulic oils, fresh water, sea water, air, up to 320 °F (160 °C) | XMLB035B2S11 | — |
| Pressure connection | | G 1/4-19 | |
| Electrical connection | Conduit/cable entry | Pg 13.5 | |
| | Terminals | 1 x 0.2 to 2 x 2.5 mm ² (1 x 24 to 2 x 14 AWG) | DIN 43650A, 4-pin male For suitable female connector, see page 57. |
| Weight, lb (kg) | | 1.58 (0.715) | 1.64 (0.745) |

Supplementary specifications (not shown under general specifications)

| | | |
|--|----------------------|---|
| Possible differential (subtract from PH to get PB) | Min. at low setting | 1.7 bar, -0.5, +0.7 (24.65 psi, -7.25, +10.15) |
| | Min. at high setting | 2.55 bar, -0.5, +0.7 (36.97 psi, -7.25, +10.15) |
| | Max. at high setting | 20 bar (290 psi) |
| Maximum allowable pressure | Per cycle | 45 bar (652.5 psi) |
| | Accidental | 80 bar (1160 psi) |
| Destruction pressure | | 160 bar (2320 psi) |
| Pressure switch style | | Diaphragm |

Operating curves **Connection**

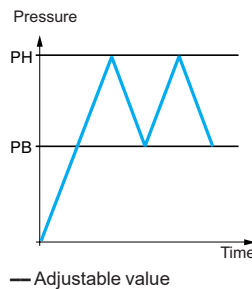
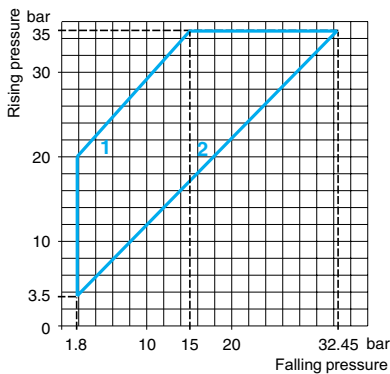

1 Maximum differential
2 Minimum differential

Terminal model



Connector model

Pressure switch connector pin view

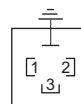

1 → 11 and 13
2 → 12
3 → 14

Other versions For switches with alternative tapped cable entries, please consult our Customer Care Center.

Size 35 bar (507.5 psi)
Adjustable differential, for regulation between two thresholds
2 C/O single-pole contacts

XMLC pressure switches **With setting scale**

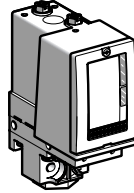

Adjustable range of operating point (PH)
(rising pressure) 3.5-35 bar (50.75-507.5 psi)

References

| | | |
|--|--|---|
| Fluids controlled For materials in contact with fluid, see page 62 | Hydraulic oils, fresh water, sea water, air, up to 320 °F (160 °C) | XMLC035B2S12 |
| Pressure connection | | G 1/4-19 |
| Electrical connection | Conduit/cable entry | ISO M20 |
| | Terminals | 1 x 0.2 to 2 x 2.5 mm ² (1 x 24 to 2 x 14 AWG) |
| Weight, lb (kg) | | 1.53 (0.695) |

Supplementary specifications (not shown under general specifications)

| | | |
|--|----------------------|--------------------------------|
| Possible differential (subtract from PH to get PB) | Min. at low setting | 1 bar ±0.2 (14.5 psi ±2.9) |
| | Min. at high setting | 1.5 bar ±0.5 (21.75 psi ±7.25) |
| | Max. at high setting | 22 bar (319 psi) |
| Maximum allowable pressure | Per cycle | 45 bar (652.5 psi) |
| | Accidental | 80 bar (1160 psi) |
| Destruction pressure | | 160 bar (2320 psi) |
| Pressure switch style | | Diaphragm |

Operating curves **Connection**

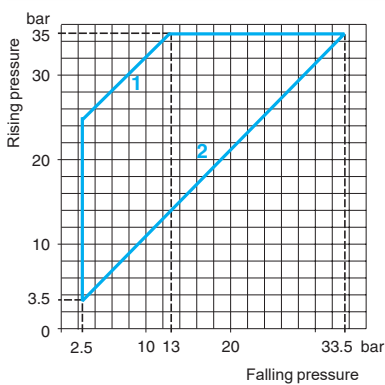

1 Maximum differential
2 Minimum differential

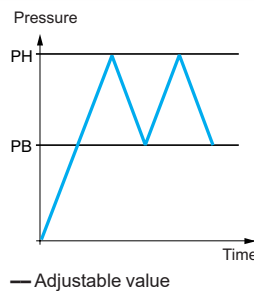

Terminal model

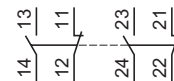

Other versions For switches with alternative tapped cable entries, please consult our Customer Care Center.

Size 35 bar (507.5 psi)
Dual-stage, fixed differential, for detection at each threshold
2 C/O single-pole contacts (one per stage)

XMLD pressure switches Without setting scale

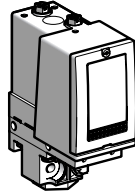

| | | |
|---|---------------------------------|---------------------------------|
| Adjustable range of each operating point (rising pressure) | 2nd stage operating point (PH2) | 4.4-35 bar (63.8-507.5 psi) |
| | 1st stage operating point (PH1) | 1.9-32.5 bar (27.55-471.25 psi) |
| Spread between the two stages (PH2-PH1) | | 2.5-20.4 bar (36.25-295.8 psi) |

References

| | | |
|---|---|---|
| Fluids controlled For materials in contact with fluid, see page 62. | Corrosive fluids, up to 320 °F (160 °C) | XMLD035B1S11 |
| Pressure connection | | G 1/4-19 |
| Electrical connection | Conduit/cable entry | Pg 13.5 |
| | Terminals | 1 x 0.2 to 2 x 2.5 mm ² (1 x 24 to 2 x 14 AWG) |
| Weight, lb (kg) | | 1.58 (0.715) |

Supplementary specifications (not shown under general specifications)

| | | |
|--|-----------------|---------------------------------|
| Inherent differential (subtract from PH1/PH2 to get PB1/PB2) | At low setting | 1.5 bar ±0.3 (21.75 psi ±4.35) |
| | At high setting | 2.6 bar, ±0.7 (37.7 psi ±10.15) |
| Maximum allowable pressure | Per cycle | 45 bar (652.5 psi) |
| | Accidental | 80 bar (1160 psi) |
| Destruction pressure | | 160 bar (2320 psi) |
| Pressure switch style | | Diaphragm |

Operating curves

High setting trip points of contacts 1 and 2

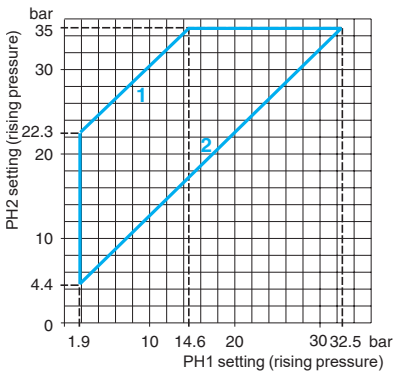

1 Maximum differential
2 Minimum differential

Inherent differential of contacts 1 and 2

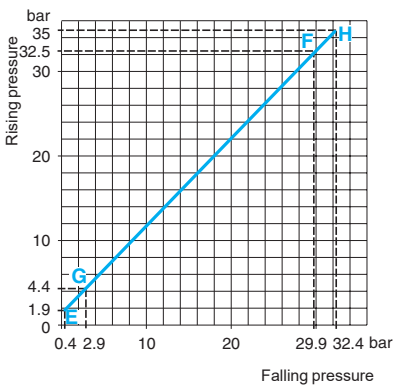

EF Contact 1 (stage 1)
GH Contact 2 (stage 2)

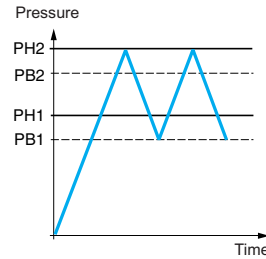

— Adjustable value
--- Nonadjustable value

Connection
Terminal model

Contact 2 (stage 2) Contact 1 (stage 1)

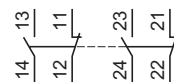

Other versions For switches with alternative tapped cable entries, please consult our Customer Care Center.

Size 70 bar (1015 psi)
Fixed differential, for detection of a single threshold
1 C/O single-pole contact

XMLA pressure switches **With setting scale**

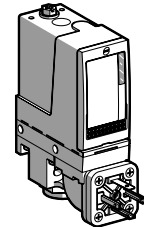
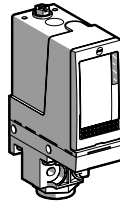

Adjustable range of operating point (PH)
(rising pressure) 5–70 bar (72.5–1015 psi)

References

| Fluids controlled | | XMLA070D2S13 | XMLA070D2S11 | XMLA070D2S12 | XMLA070D2C11 |
|--|---|--------------|--------------|--------------|--------------|
| For materials in contact with fluid, see page 62 | Hydraulic oils, up to 320 °F (160 °C) | | | | |
| | Fresh water, sea water, up to 320 °F (160 °C) | XMLA070E2S13 | XMLA070E2S11 | – | – |
| | Corrosive fluids, air, up to 320 °F (160 °C) | – | XMLA070N2S11 | XMLA070N2S12 | – |

Pressure connection 1/4"-18 NPTF G 1/4-19

| Electrical connection | Conduit/cable entry | 1/2" NPT | Pg 13.5 | ISO M20 | DIN 43650A, 4-pin male |
|-----------------------|---------------------|---|---------|---------|---|
| | Terminals | 1 x 0.2 to 2 x 2.5 mm ² (1 x 24 to 2 x 14 AWG) | | | For suitable female connector, see page 57. |

Weight, lb (kg) 1.53 (0.695) 1.60 (0.725)

Supplementary specifications (not shown under general specifications)

| | | |
|--|-----------------|-------------------------------|
| Inherent differential (subtract from PH to get PB) | At low setting | 3 bar ±1 (43.5 psi ±14.5) |
| | At high setting | 7.5 bar ±1 (108.75 psi ±14.5) |
| Maximum allowable pressure | Per cycle | 90 bar (1035 psi) |
| | Accidental | 160 bar (2320 psi) |
| Destruction pressure | | 320 bar (4640 psi) |
| Pressure switch style | | Piston |

Operating curves **Connection**

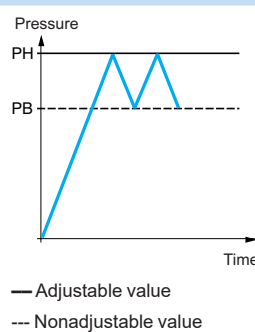
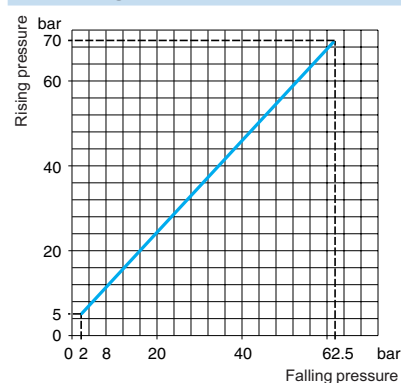

Terminal model



Connector model

Pressure switch connector pin view

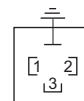

- 1 → 11 and 13
- 2 → 12
- 3 → 14

Other versions For switches with alternative tapped cable entries, please consult our Customer Care Center.

Size 70 bar (1015 psi)
Adjustable differential, for regulation between two thresholds
1 C/O single-pole contact

XMLB pressure switches **With setting scale**

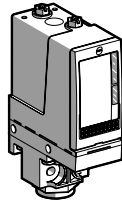

Adjustable range of operating point (PH)
(rising pressure) | 7–70 bar (101.5–1015 psi)

References

| | | |
|---|--|---------------------|
| Fluids controlled For materials in contact with fluid, see page 62. | Hydraulic oils, up to 320 °F (160 °C) | XMLB070D2S11 |
| | Corrosive fluids, air, up to 320 °F (160 °C) | XMLB070N2S11 |

Pressure connection | G 1/4-19

Electrical connection | Conduit/cable entry Pg 13.5
Terminals 1 x 0.2 to 2 x 2.5 mm² (1 x 24 to 2 x 14 AWG)

Weight, lb (kg) | 1.58 (0.715)

Supplementary specifications (not shown under general specifications)

| | | |
|--|----------------------|---|
| Possible differential (subtract from PH to get PB) | Min. at low setting | 4.7 bar, -0.4, +0.7 (68.15 psi, -5.8, +10.15) |
| | Min. at high setting | 8.8 bar, -0.6, +0.8 (127.6 psi, -8.7, +11.6) |
| | Max. at high setting | 50 bar (725 psi) |
| Maximum allowable pressure | Per cycle | 90 bar (1035 psi) |
| | Accidental | 160 bar (2320 psi) |
| Destruction pressure | | 320 bar (4640 psi) |
| Pressure switch style | | Piston |

Operating curves **Connection**

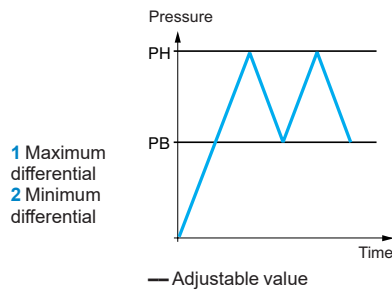
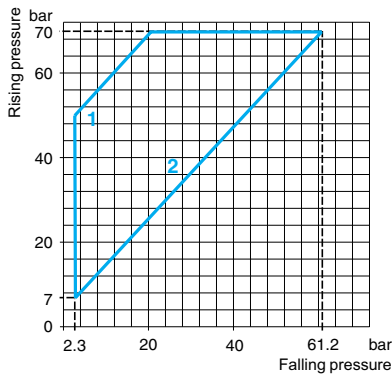

1 Maximum differential
2 Minimum differential

Terminal model



Connector model

Pressure switch connector pin view

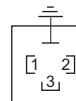

1 → 11 and 13
2 → 12
3 → 14

Other versions For switches with alternative tapped cable entries, please consult our Customer Care Center.

Size 160 bar (2320 psi)
Fixed differential, for detection of a single threshold
1 C/O single-pole contact

XMLA pressure switches **With setting scale**

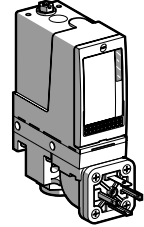
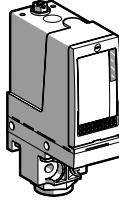

Adjustable range of operating point (PH)
(rising pressure) | 10–160 bar (145–2320 psi)

References

| | | | | | |
|---|---|---------------------|---------------------|---------------------|---------------------|
| Fluids controlled For materials in contact with fluid, see page 62. | Hydraulic oils, up to 320 °F (160 °C) | XMLA160D2S13 | XMLA160D2S11 | XMLA160D2S12 | XMLA160D2C11 |
| | Fresh water, sea water, up to 320 °F (160 °C) | — | XMLA160E2S11 | — | — |
| | Corrosive fluids, air, up to 320 °F (160 °C) | — | XMLA160N2S11 | — | XMLA160N2C11 |

Pressure connection | 1/4"-18 NPTF | G 1/4-19

| | | | | | |
|------------------------------|---------------------|---|---------|---------|---|
| Electrical connection | Conduit/cable entry | 1/2" NPT | Pg 13.5 | ISO M20 | DIN 43650A, 4-pin male. |
| | Terminals | 1 x 0.2 to 2 x 2.5 mm ² (1 x 24 to 2 x 14 AWG) | | | For suitable female connector, see page 57. |

Weight, lb (kg) | 1.65 (0.750) | 1.72 (0.780)

Supplementary specifications (not shown under general specifications)

| | | |
|--|-----------------|--------------------------------------|
| Inherent differential (subtract from PH to get PB) | At low setting | 5.5 bar ±1 (79.75 psi ±14.5) |
| | At high setting | 18 bar ±3 (261 psi ±43.5) |
| Maximum allowable pressure | Per cycle | 200 bar (2900 psi) |
| | Accidental | 360 bar (5220 psi) |
| Destruction pressure | | 720 bar (10,440 psi) |
| Mechanical life (depending on the application) | | 6 x 10 ⁶ operating cycles |
| Pressure switch style | | Piston |

Operating curves **Connection**

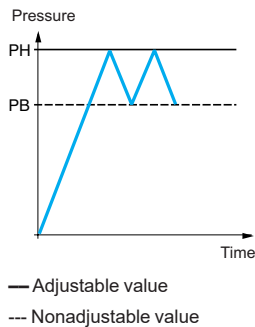
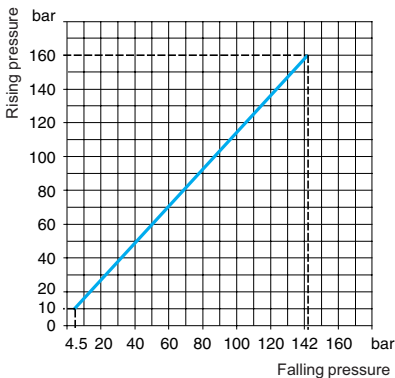

Terminal model



Connector model

Pressure switch connector pin view

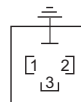

- 1 → 11 and 13
- 2 → 12
- 3 → 14

Other versions For switches with alternative tapped cable entries, please consult our Customer Care Center.

Size 160 bar (2320 psi)
Adjustable differential, for regulation between two thresholds
1 C/O single-pole contact

XMLB pressure switches **With setting scale**

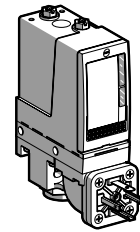
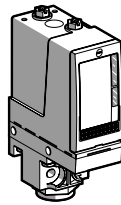

| | | | |
|--|---------------------------|--|--|
| Adjustable range of operating point (PH) (rising pressure) | 10–160 bar (145–2320 psi) | | |
|--|---------------------------|--|--|

References

| | | | | |
|---|--|---------------------|---------------------|---------------------|
| Fluids controlled For materials in contact with fluid, see page 62. | Hydraulic oils, up to 320 °F (160 °C) | XMLB160D2S11 | XMLB160D2S12 | XMLB160D2C11 |
| | Corrosive fluids, air, up to 320 °F (160 °C) | XMLB160N2S11 | – | – |

| | | | | |
|------------------------------|---------------------|---|--------------|---|
| Pressure connection | G 1/4-19 | | | |
| Electrical connection | Conduit/cable entry | Pg 13.5 | ISO M20 | DIN 43650A, 4-pin male. |
| | Terminals | 1 x 0.2 to 2 x 2.5 mm ² (1 x 24 to 2 x 14 AWG) | | For suitable female connector, see page 57. |
| Weight, lb (kg) | 1.65 (0.750) | | 1.72 (0.780) | |

Supplementary specifications (not shown under general specifications)

| | | | | |
|--|----------------------|---|--|--|
| Possible differential (subtract from PH to get PB) | Min. at low setting | 9.3 bar, –1.8, +1.5 (134.85 psi, –26.1, +21.75) | | |
| | Min. at high setting | 20.8 bar, –1.9, +1.6 (301.6 psi, –27.55, +23.2) | | |
| | Max. at high setting | 100 bar (1450 psi) | | |
| Maximum allowable pressure | Per cycle | 200 bar (2900 psi) | | |
| | Accidental | 360 bar (5220 psi) | | |
| Destruction pressure | 720 bar (10,440 psi) | | | |
| Pressure switch style | Piston | | | |

Operating curves **Connection**

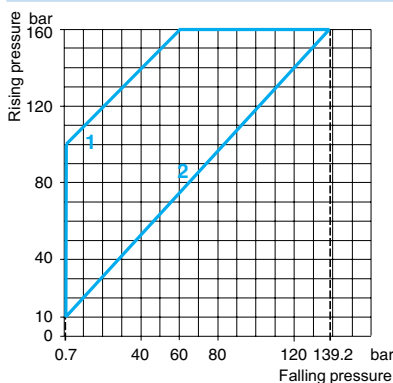

1 Maximum differential
2 Minimum differential

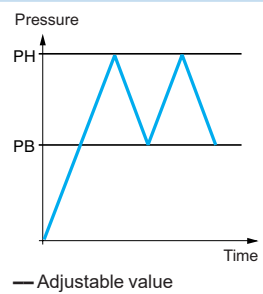

Terminal model



Connector model

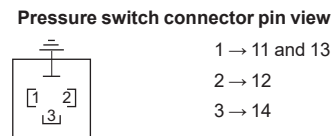

Other versions For switches with alternative tapped cable entries, please consult our Customer Care Center.

Size 160 bar (2320 psi)

Adjustable differential, for regulation between two thresholds

2 C/O single-pole contacts

XMLC pressure switches **With setting scale**

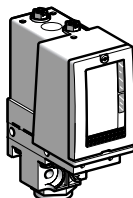

| | |
|--|---------------------------|
| Adjustable range of operating point (PH) (rising pressure) | 12–160 bar (174–2320 psi) |
|--|---------------------------|

References

| | | |
|---|---------------------|---|
| Fluids controlled Hydraulic oils, up to 320 °F (160 °C) For materials in contact with fluid, see page 62 | XMLC160D2S11 | XMLC160D2S12 |
| Pressure connection | G 1/4-19 | |
| Electrical connection | Conduit/cable entry | Pg 13.5 |
| | Terminals | 1 x 0.2 to 2 x 2.5 mm ² (1 x 24 to 2 x 14 AWG) |
| Weight, lb (kg) | 1.65 (0.750) | |

Supplementary specifications (not shown under general specifications)

| | | |
|--|--------------------------------------|--------------------------------|
| Possible differential (subtract from PH to get PB) | Min. at low setting | 9 bar ±0.9 (130.5 psi ±13.05) |
| | Min. at high setting | 21 bar ±0.9 (304.5 psi ±13.05) |
| | Max. at high setting | 110 bar (1590 psi) |
| Maximum allowable pressure | Per cycle | 200 bar (2900 psi) |
| | Accidental | 360 bar (5220 psi) |
| Destruction pressure | 720 bar (10,440 psi) | |
| Mechanical life (depending on the application) | 6 x 10 ⁶ operating cycles | |
| Pressure switch style | Piston | |

Operating curves **Connection**

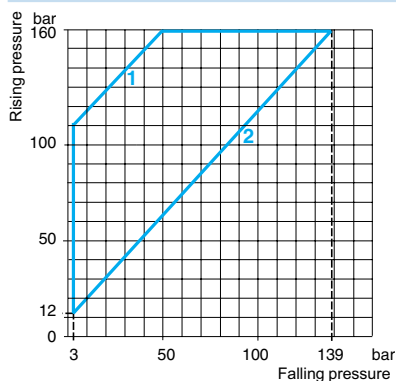

1 Maximum differential
2 Minimum differential

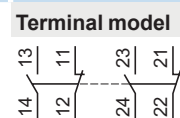
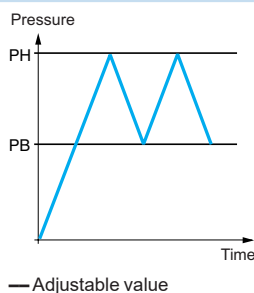

Other versions

For switches with alternative tapped cable entries, please consult our Customer Care Center.

Size 160 bar (2320 psi)
Dual-stage, fixed differential, for detection at each threshold
2 C/O single-pole contacts (one per stage)

XMLD pressure switches Without setting scale

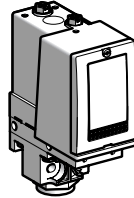

| | | |
|---|---------------------------------|--------------------------------|
| Adjustable range of each operating point (rising pressure) | 2nd stage operating point (PH2) | 16.5–160 bar (239.25–2320 psi) |
| | 1st stage operating point (PH1) | 10.5–154 bar (152.25–2233 psi) |
| Spread between the two stages (PH2–PH1) | | 6–83 bar (87–1203.5 psi) |

References

| | | |
|--|---------------------|---|
| Fluids controlled Hydraulic oils, up to 320 °F (160 °C) For materials in contact with fluid, see page 62. | XMLD160D1S13 | |
| Pressure connection | 1/4"-18 NPTF | |
| Electrical connection | Conduit/cable entry | 1/2" NPT |
| | Terminals | 1 x 0.2 to 2 x 2.5 mm ² (1 x 24 to 2 x 14 AWG) |
| Weight, lb (kg) | 1.65 (0.750) | |

Supplementary specifications (not shown under general specifications)

| | | |
|--|-----------------|---------------------------------|
| Inherent differential (subtract from PH1/PH2 to get PB1/PB2) | At low setting | 8.8 bar ±1.5 (127.6 psi ±21.75) |
| | At high setting | 20 bar ±7 (290 psi ±101.5) |
| Maximum allowable pressure | Per cycle | 200 bar (2900 psi) |
| | Accidental | 360 bar (5220 psi) |
| Destruction pressure | | 720 bar (10,440 psi) |
| Pressure switch style | | Piston |

Operating curves

High setting trip points of contacts 1 and 2

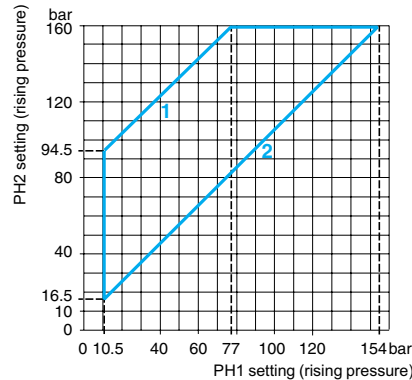

1 Maximum differential
2 Minimum differential

Inherent differential of contacts 1 and 2

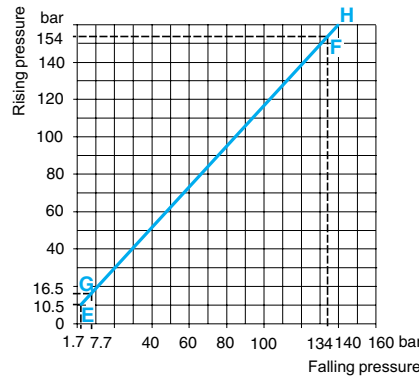

EF Contact 1 (stage 1)
GH Contact 2 (stage 2)

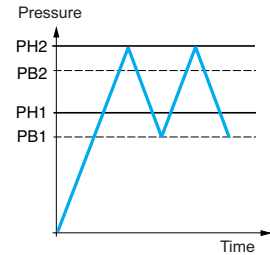

— Adjustable value
--- Nonadjustable value

Connection

Terminal model

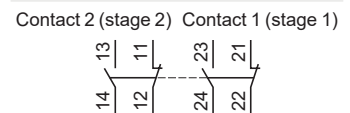

Other versions For switches with alternative tapped cable entries, please consult our Customer Care Center.

Size 300 bar (4350 psi)
Fixed differential, for detection of a single threshold
1 C/O single-pole contact

XMLA pressure switches **With setting scale**

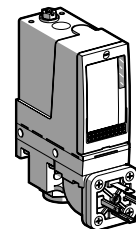
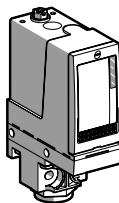

| | | | | | |
|--|---|---|---------------------|---------------------|---|
| Adjustable range of operating point (PH) (rising pressure) | 20–300 bar (290–4350 psi) | | | | |
| Electrical connection | Terminals | | DIN connector | | |
| References | | | | | |
| Fluids controlled For materials in contact with fluid, see page 62. Only for control of group 2 fluids, in accordance with directive 97/23/EEC. | Hydraulic oils, up to 320 °F (160 °C) | XMLA300D2S13 | XMLA300D2S11 | XMLA300D2S12 | XMLA300D2C11 |
| | Fresh water, sea water, up to 320 °F (160 °C) | — | XMLA300E2S11 | XMLA300E2S12 | — |
| | Corrosive fluids, air, up to 320 °F (160 °C) | — | XMLA300N2S11 | — | — |
| Pressure connection | | 1/4"-18 NPTF | G 1/4-19 | | |
| Electrical connection | Conduit/cable entry | 1/2" NPT | Pg 13.5 | ISO M20 | DIN 43650A, 4-pin male |
| | Terminals | 1 x 0.2 to 2 x 2.5 mm ² (1 x 24 to 2 x 14 AWG) | | | For suitable female connector, see page 57. |
| Weight, lb (kg) | 1.65 (0.750) | | | 1.72 (0.780) | |

Supplementary specifications (not shown under general specifications)

| | | |
|--|-----------------|--------------------------------|
| Inherent differential (subtract from PH to get PB) | At low setting | 16.5 bar ±3 (239.25 psi ±43.5) |
| | At high setting | 35 bar ±6 (507.5 psi ±87) |
| Maximum allowable pressure | Per cycle | 375 bar (5437.5 psi) |
| | Accidental | 675 bar (9787.5 psi) |
| Destruction pressure | | 1350 bar (19,575 psi) |
| Pressure switch style | | Piston |

Operating curves **Connection**

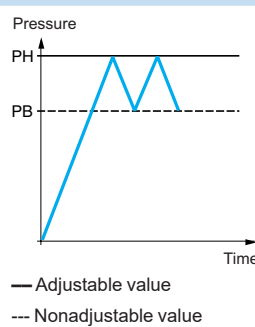
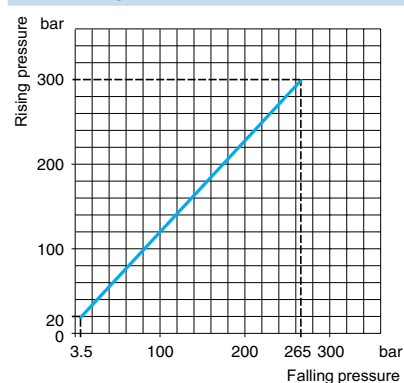

Terminal model

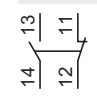

Connector model

Pressure switch connector pin view

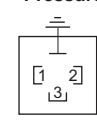

- 1 → 11 and 13
- 2 → 12
- 3 → 14

Other versions For switches with alternative tapped cable entries, please consult our Customer Care Center.

Size 300 bar (4350 psi)
Adjustable differential, for regulation between two thresholds
1 C/O single-pole contact

XMLB pressure switches **With setting scale**

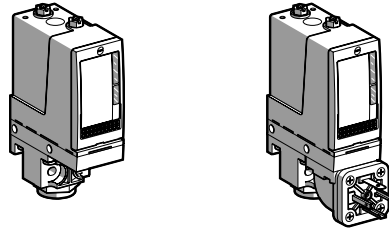

| | | | |
|--|---------------------------|--|--|
| Adjustable range of operating point (PH) (rising pressure) | 22–300 bar (319–4350 psi) | | |
|--|---------------------------|--|--|

References

| | | | | |
|--|--|---------------------|---------------------|---------------------|
| Fluids controlled For materials in contact with fluid, see page 62. Only for control of group 2 fluids, in accordance with directive 97/23/EEC. | Hydraulic oils, up to 320 °F (160 °C) | XMLB300D2S11 | XMLB300D2S12 | XMLB300D2C11 |
| | Corrosive fluids, air, up to 320 °F (160 °C) | – | XMLB300N2S12 | – |

| | | | |
|----------------------------|----------|--|--|
| Pressure connection | G 1/4-19 | | |
|----------------------------|----------|--|--|

| | | | | |
|------------------------------|---------------------|---|---------|---|
| Electrical connection | Conduit/cable entry | Pg 13.5 | ISO M20 | DIN 43650A, 4-pin male. |
| | Terminals | 1 x 0.2 to 2 x 2.5 mm ² (1 x 24 to 2 x 14 AWG) | | For suitable female connector, see page 57. |

| | | |
|------------------------|--------------|--------------|
| Weight, lb (kg) | 1.65 (0.750) | 1.72 (0.780) |
|------------------------|--------------|--------------|

Supplementary specifications (not shown under general specifications)

| | | |
|--|----------------------|---|
| Possible differential (subtract from PH to get PB) | Min. at low setting | 19.4 bar –1.5, +1.7 (281.3 psi, –21.75, +24.65) |
| | Min. at high setting | 37 bar, –1, +4 (536.5 psi, –14.5, +58) |
| | Max. at high setting | 200 bar (2900 psi) |

| | | |
|-----------------------------------|------------|----------------------|
| Maximum allowable pressure | Per cycle | 375 bar (5437.5 psi) |
| | Accidental | 675 bar (9787.5 psi) |

| | |
|-----------------------------|-----------------------|
| Destruction pressure | 1350 bar (19,575 psi) |
|-----------------------------|-----------------------|

| | |
|------------------------------|--------|
| Pressure switch style | Piston |
|------------------------------|--------|

Operating curves **Connection**

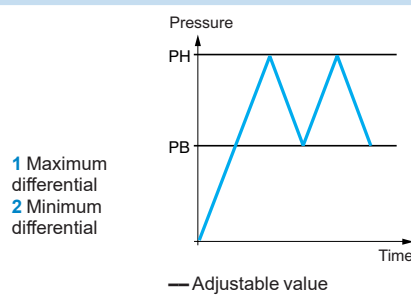
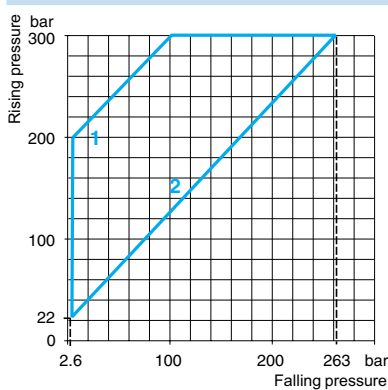

Terminal model

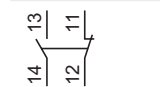

Connector model



Other versions For switches with alternative tapped cable entries, please consult our Customer Care Center.

Size 300 bar (4350 psi)

Adjustable differential, for regulation between two thresholds

2 C/O single-pole contacts

XMLC pressure switches **With setting scale**

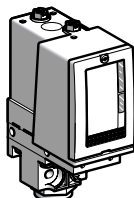

| | |
|--|---------------------------|
| Adjustable range of operating point (PH) (rising pressure) | 22–300 bar (319–4350 psi) |
|--|---------------------------|

References

| | | | | |
|--|---------------------------------------|---------------------|---------------------|---------------------|
| Fluids controlled For materials in contact with fluid, see page 62. Only for control of group 2 fluids, in accordance with directive 97/23/EEC. | Hydraulic oils, up to 320 °F (160 °C) | XMLC300D2S13 | XMLC300D2S11 | XMLC300D2S12 |
|--|---------------------------------------|---------------------|---------------------|---------------------|

| | | |
|----------------------------|--------------|----------|
| Pressure connection | 1/4"-18 NPTF | G 1/4-19 |
|----------------------------|--------------|----------|

| | | | | |
|------------------------------|---------------------|---|---------|---------|
| Electrical connection | Conduit/cable entry | 1/2" NPT | Pg 13.5 | ISO M20 |
| | Terminals | 1 x 0.2 to 2 x 2.5 mm ² (1 x 24 to 2 x 14 AWG) | | |

| | |
|------------------------|--------------|
| Weight, lb (kg) | 1.65 (0.750) |
|------------------------|--------------|

Supplementary specifications (not shown under general specifications)

| | | |
|--|----------------------|--------------------------------------|
| Possible differential (subtract from PH to get PB) | Min. at low setting | 16 bar ±0.9 (232 psi ±13.05) |
| | Min. at high setting | 35 bar ±0.9 (507.5 psi ±13.05) |
| | Max. at high setting | 240 bar (3480 psi) |
| Maximum allowable pressure | Per cycle | 375 bar (5437.5 psi) |
| | Accidental | 675 bar (9787.5 psi) |
| Destruction pressure | | 1350 bar (19,575 psi) |
| Mechanical life (depending on the application) | | 3 x 10 ⁶ operating cycles |
| Pressure switch style | | Piston |

Operating curves **Connection**

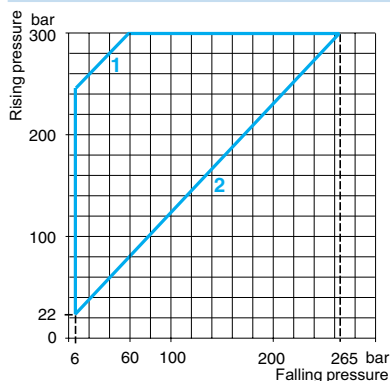

1 Maximum differential
2 Minimum differential

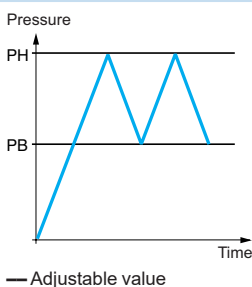

Terminal model

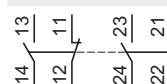

Other versions

For switches with alternative tapped cable entries, please consult our Customer Care Center.

Size 500 bar (7250 psi)
Fixed differential, for detection of a single threshold
1 C/O single-pole contact

XMLA pressure switches **With setting scale** **Without setting scale**

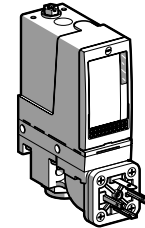
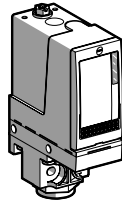

Adjustable range of operating point (PH)
(rising pressure) 30–500 bar (435–7250 psi)

References

| | | | | | |
|--|--|---------------------|---------------------|---------------------|---------------------|
| Fluids controlled For materials in contact with fluid, see page 62. Only for control of group 2 fluids, in accordance with directive 97/23/EEC. | Hydraulic oils, up to 320 °F (160 °C) | XMLA500D2S13 | XMLA500D2S11 | XMLA500D2S12 | – |
| | Corrosive fluids, air, up to 320 °F (160 °C) | – | XMLA500N2S11 | – | XMLA500N2C11 |

Pressure connection 1/4"-18 NPTF G 1/4-19

| | | | | | |
|------------------------------|---------------------|---|---------|---------|---|
| Electrical connection | Conduit/cable entry | 1/2" NPT | Pg 13.5 | ISO M20 | DIN 43650A, 4-pin male |
| | Terminals | 1 x 0.2 to 2 x 2.5 mm ² (1 x 24 to 2 x 14 AWG) | | | For suitable female connector, see page 57. |

Weight, lb (kg) 1.65 (0.750) 1.72 (0.780)

Supplementary specifications (not shown under general specifications)

| | | |
|--|-----------------|--------------------------------------|
| Inherent differential (subtract from PH to get PB) | At low setting | 20 bar ±6 (290 psi ±87) |
| | At high setting | 45 bar ±10 (652.5 psi ±145) |
| Maximum allowable pressure | Per cycle | 625 bar (9062.5 psi) |
| | Accidental | 1125 bar (16,312.5 psi) |
| Destruction pressure | | 2250 bar (32,625 psi) |
| Mechanical life (depending on the application) | | 3 x 10 ⁶ operating cycles |
| Pressure switch style | | Piston |

Operating curves **Connection**

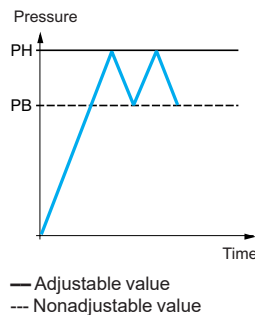
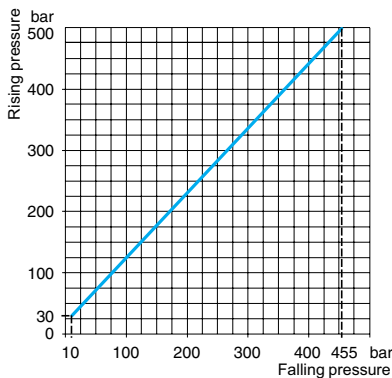

Terminal model



Connector model

Pressure switch connector pin view

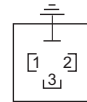

- 1 → 11 and 13
- 2 → 12
- 3 → 14

Other versions For switches with alternative tapped cable entries, please consult our Customer Care Center.

Size 500 bar (7250 psi)

Adjustable differential, for regulation between two thresholds

1 C/O single-pole contact

XMLB pressure switches **With setting scale**

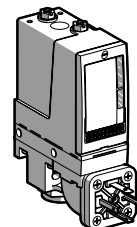
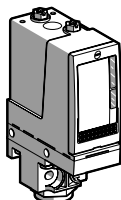

| | |
|--|---------------------------|
| Adjustable range of operating point (PH) (rising pressure) | 30–500 bar (435–7250 psi) |
|--|---------------------------|

References

| | | | | |
|--|--|---------------------|---------------------|---------------------|
| Fluids controlled For materials in contact with fluid, see page 62. Only for control of group 2 fluids, in accordance with directive 97/23/EEC. | Hydraulic oils, up to 320 °F (160 °C) | XMLB500D2S11 | XMLB500D2S12 | XMLB500D2C11 |
| | Corrosive fluids, air, up to 320 °F (160 °C) | XMLB500N2S11 | XMLB500N2S12 | XMLB500N2C11 |

| | |
|----------------------------|----------|
| Pressure connection | G 1/4-19 |
|----------------------------|----------|

| | | | | |
|------------------------------|---------------------|---|---------|---|
| Electrical connection | Conduit/cable entry | Pg 13.5 | ISO M20 | DIN 43650A, 4-pin male |
| | Terminals | 1 x 0.2 to 2 x 2.5 mm ² (1 x 24 to 2 x 14 AWG) | | For suitable female connector, see page 57. |

| | | |
|------------------------|--------------|--------------|
| Weight, lb (kg) | 1.65 (0.750) | 1.72 (0.780) |
|------------------------|--------------|--------------|

Supplementary specifications (not shown under general specifications)

| | | |
|--|----------------------|--|
| Possible differential (subtract from PH to get PB) | Min. at low setting | 23 bar, -2.6, +3.8 (333.5 psi, -37.7, +55.1) |
| | Min. at high setting | 52.6 bar, -14.8, +11.2 (762.7 psi, -214.6, +162.4) |
| | Max. at high setting | 300 bar (4350 psi) |

| | | |
|-----------------------------------|------------|-------------------------|
| Maximum allowable pressure | Per cycle | 625 bar (9062.5 psi) |
| | Accidental | 1125 bar (16,312.5 psi) |

| | |
|-----------------------------|-----------------------|
| Destruction pressure | 2250 bar (32,625 psi) |
|-----------------------------|-----------------------|

| | |
|------------------------------|--------|
| Pressure switch style | Piston |
|------------------------------|--------|

Operating curves **Connection**

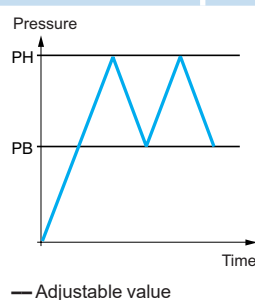
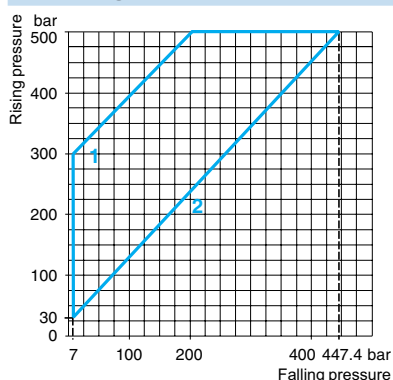

Terminal model



Connector model

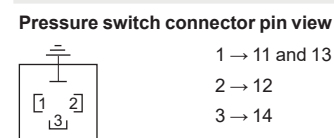

Other versions For switches with alternative tapped cable entries, please consult our Customer Care Center.

Size 500 bar (7250 psi)
Dual-stage, fixed differential, for detection at each threshold
2 C/O single-pole contacts (one per stage)

XMLD pressure switches Without setting scale

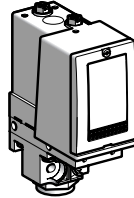

| | | |
|---|---------------------------------|-----------------------------|
| Adjustable range of each operating point (rising pressure) | 2nd stage operating point (PH2) | 41–500 bar (594.5–7250 psi) |
| | 1st stage operating point (PH1) | 25–484 bar (362.5–7018 psi) |
| Spread between the two stages (PH2–PH1) | | 16–244 bar (232–3538 psi) |

References

| | | |
|--|---------------------------------------|---|
| Fluids controlled For materials in contact with fluid, see page 62. Only for control of group 2 fluids, in accordance with directive 97/23/EEC. | Hydraulic oils, up to 320 °F (160 °C) | XMLD500D1S11 |
| Pressure connection | | G 1/4-19 |
| Electrical connection | Conduit/cable entry | Pg 13.5 conduit/cable entry |
| | Terminals | 1 x 0.2 to 2 x 2.5 mm ² (1 x 24 to 2 x 14 AWG) |
| Weight, lb (kg) | | 1.65 (0.750) |

Supplementary specifications (not shown under general specifications)

| | | |
|--|-----------------|-----------------------------|
| Inherent differential (subtract from PH1/PH2 to get PB1/PB2) | At low setting | 21 bar ±3 (304.5 psi ±43.5) |
| | At high setting | 65 bar ±10 (942.5 psi ±145) |
| Maximum allowable pressure | Per cycle | 625 bar (9,062.5 psi) |
| | Accidental | 1125 bar (16,312.5 psi) |
| Destruction pressure | | 2250 bar (32,625 psi) |
| Pressure switch style | | Piston |

Operating curves

High setting trip points of contacts 1 and 2

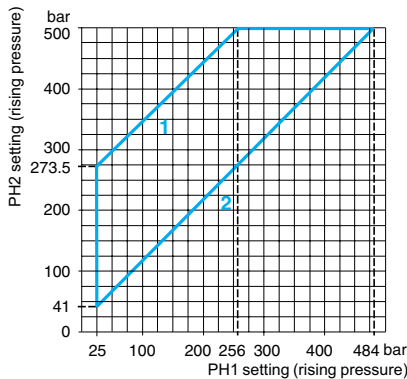

- 1 Maximum differential
- 2 Minimum differential

Inherent differential of contacts 1 and 2

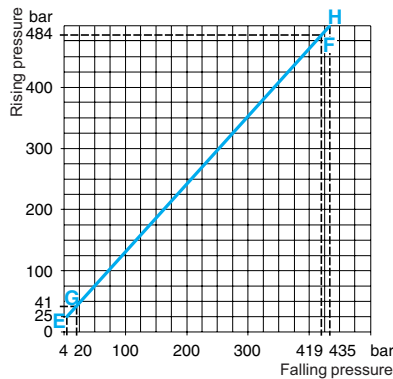

- EF Contact 1 (stage 1)
- GH Contact 2 (stage 2)

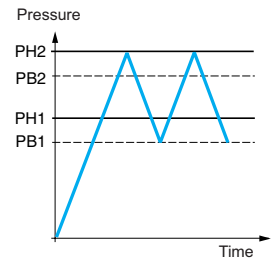

- Adjustable value
- Nonadjustable value

Connection

Terminal model

Contact 2 (stage 2) Contact 1 (stage 1)

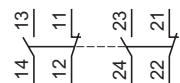

Other versions

For switches with alternative tapped cable entries, please consult our Customer Care Center.

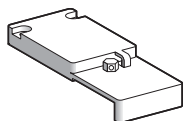

XMLZL001

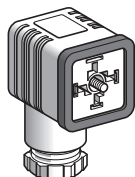

XZCC43FCP40B

Accessories for pressure switches and vacuum switches

| Description | Specific characteristics | For use with switches | Reference | Weight lb (kg) |
|---|--------------------------|-----------------------|---------------|----------------|
| Lead sealable protective cover to prevent unauthorized access to adjustment screws and fixing screw of switch cover | – | XMLA XMLB | XMLZL001 | 0.08 (0.035) |
| Female connector, DIN 43650A | – | XML●●●●●●C11 | XZCC43FCP40B | 0.08 (0.035) |
| Jumper cable, DIN 43650A - M12, straight male, for splitter boxes | 1 m | XML●●●●●●C11 | XZCR1523062K1 | 0.18 (0.080) |

Renewal parts

| Description | Specific characteristics | For use with switches | Catalog number | Weight lb (kg) |
|-------------|--------------------------|-----------------------|----------------|----------------|
| Diaphragms | – | XML●S35 | XMLZL013 | 0.13 (0.060) |
| | – | XML●S02 | XMLZL014 | 0.09 (0.040) |

Connection

| Connector pinout | Jumper cable, DIN 43650A, M12 straight male |
|------------------|---|
| XZCC43FCP40B | XZCR1523062K1 |

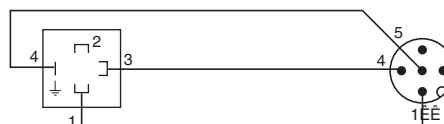
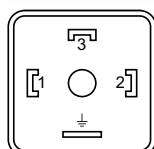

Cable connections

| XZCPV, XZCP | XZCC43F | XZCC12F |
|-------------|---------|---------|
| | | |

Electromechanical pressure and vacuum switches

XML range

XML•L35, XML•001, XML•S

mm
in.

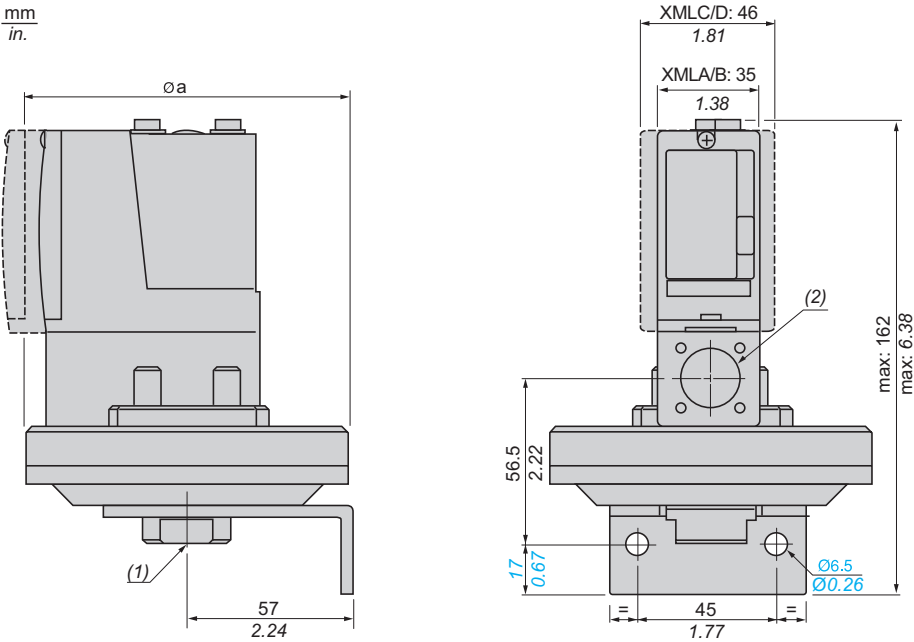

- (1) 1 fluid entry, tapped G 1/4 (BSP female).
- (2) 1 electrical connection entry, tapped M20 x 1.5, Pg 13.5, or 1/4"-18 NTP.

XMLBM03, XMLBL05

mm
in.

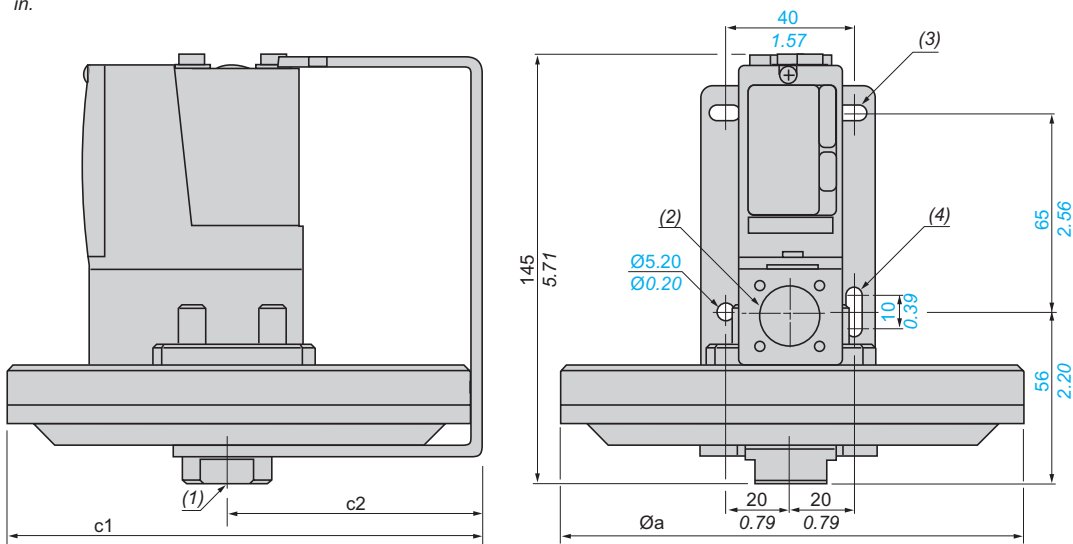

| XML | $\varnothing a$ | c1 | c2 |
|------------------|-----------------|--------------|-------------|
| BM03 | 150 (5.91) | 155.5 (6.12) | 80.5 (3.17) |
| BL05 | 200 (7.87) | 204 (8.03) | 104 (4.09) |
| •L35, •001 | 110 (4.33) | - | - |
| •S35, •S02, •S04 | 110 (4.33) | - | - |
| •S10, •S20 | 86 (3.39) | - | - |

- (1) 1 fluid entry, tapped G 1/4 (BSP female)
- (2) 1 electrical connection entry, tapped M20 x 1.5, Pg 13.5, or 1/2" NTP
- (3) 2 elongated holes $\varnothing 10.2 \times 5.2$ (0.40 x 0.20)
- (4) 1 elongated hole $\varnothing 15.2 \times 5.2$ (0.60 x 0.20)

XMLAM01, XMLBM05, XMLCM05, XMLA004, XML●010 to 500

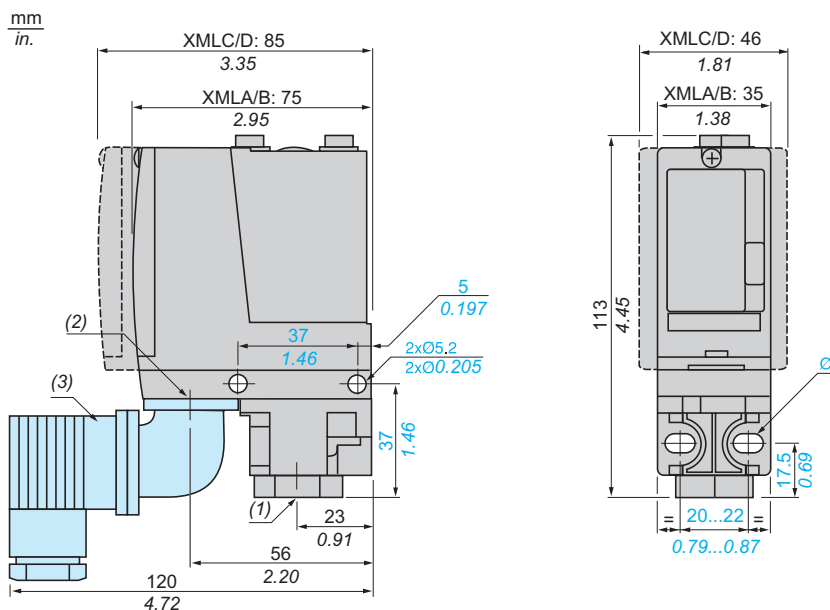

- (1) 1 fluid entry, tapped G 1/4 (BSP female).
 - (2) 1 electrical connection entry, tapped M20 x 1.5, Pg 13.5, or 1/4"-18 NTP.
 - (3) DIN connector.
- Ø: 2 elongated holes, Ø5.2 x 6.7

XML●M02, XML●002, XMLB004, XMLC004, XMLD004

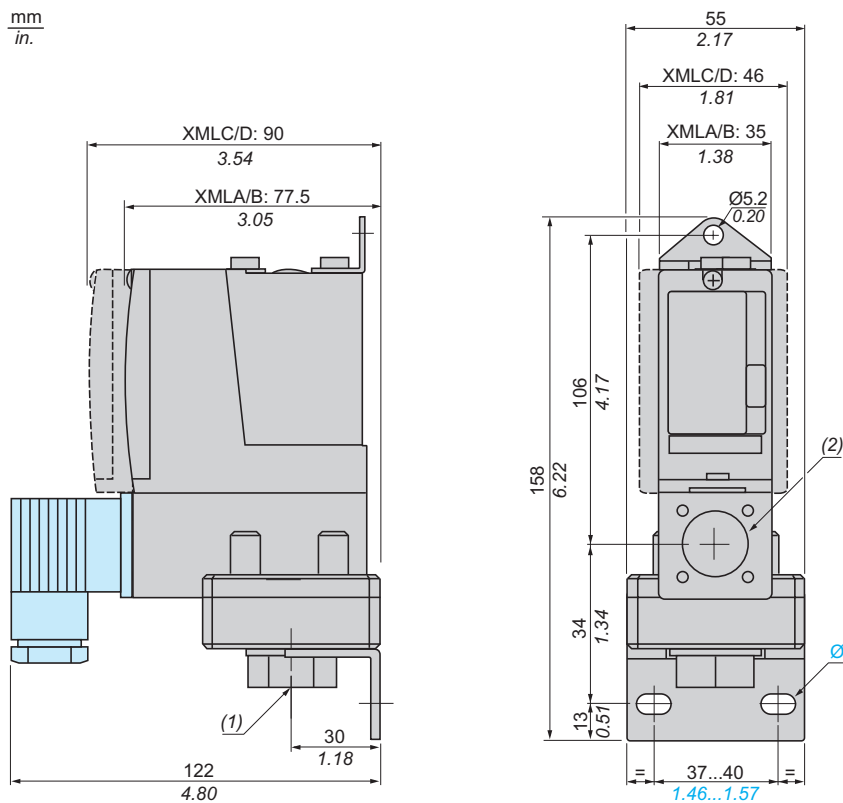

- (1) 1 fluid entry, tapped G 1/4 (BSP female).
 - (2) 1 electrical connection entry, tapped M20 x 1.5, Pg 13.5, or 1/4"-18 NTP.
- Ø: 2 elongated holes, Ø10.2 x 5.2

XMLBL35P, XMLB001P (for viscous products)

mm
in.

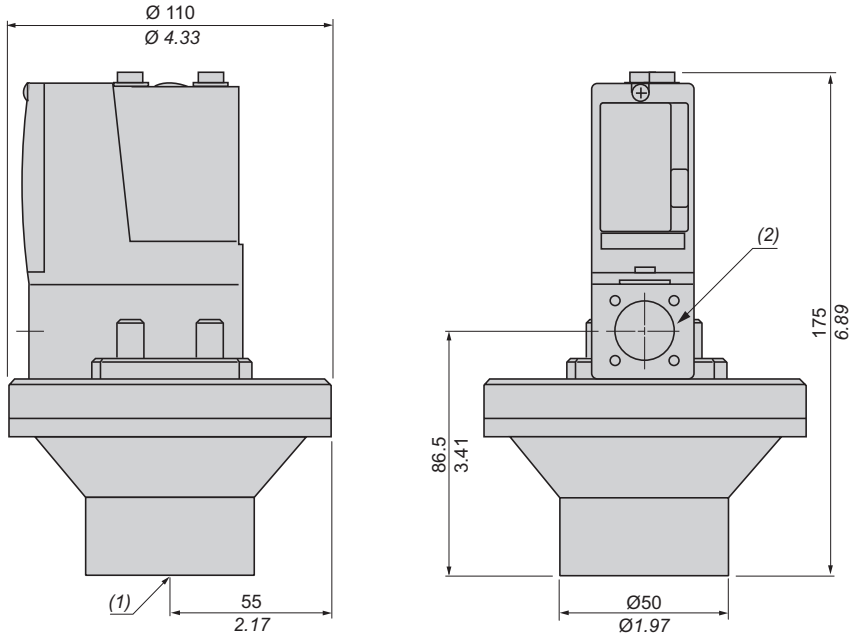

(1) 1 fluid entry, tapped G 1-1/4 (BSP female)

(2) 1 electrical connection entry, tapped M20 x 1.5 or Pg 13.5.

XMLBM05P, XMLA004P, XML●010P, XML●020P, XML●035P (for viscous products)

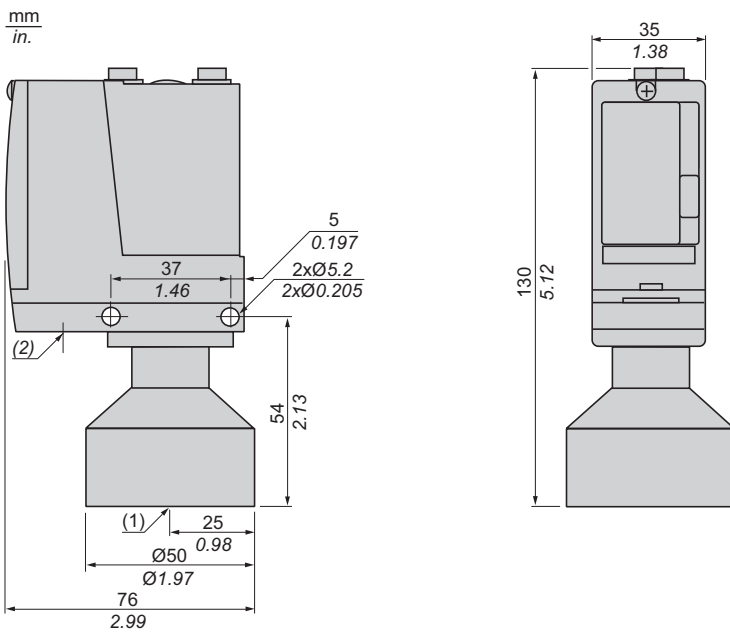

| Component Materials in Contact with Fluid | | | | | | | | |
|---|------------|-----------------|-------|-------|---------|------|----------|-----------|
| Pressure or vacuum switch catalog number | Zinc alloy | Stainless steel | Brass | Steel | Nitrile | PTFE | FPM, FKM | Aluminium |
| XMLAM01V●●●●, XML●M02V●●●● | | (1) | | | | | | |
| XMLAM01T●●●●, XML●M02T●●●● | | (2) | | | | | | |
| XMLBM03R●●●● | | | | | | | | |
| XMLBM03S●●●● | | (3) | | | | | | |
| XML●M05A●●●● | | (1) | | | | | | |
| XML●M05B●●●● | | (1) | | | | | | |
| XML●M05C●●●● | | (1) | | | | | | |
| XMLBM05●●●● | | (1) | | | | | | |
| XMLBL05R●●●● | | | | | | | | |
| XMLBL05S●●●● | | (3) | | | | | | |
| XML●L35R●●●●, XML●S35R●●●● | | (1) | | | | | | |
| XML●L35S●●●● | | (3) | | | | | | |
| XMLBL35P●●●● | | (1) | | | | | | |
| XML●001R●●●● | | (1) | | | | | | |
| XML●001S●●●● | | (3) | | | | | | |
| XMLB001P●●●● | | (1) | | | | | | |
| XML●002A●●●● | | | | | | | | |
| XML●002B●●●●, XML●S02B●●●● | | | | | | | | |
| XML●002C●●●● | | (3) | | | | | | |
| XMLA004A●●●● | | | | | | | | |
| XMLA004B●●●● | | | | | | | | |
| XMLA004C●●●● | | (2) | | | | | | |
| XMLA004P●●●● | | | | | | | | |

(1) 1.4307 (AISI 316L)
 (2) 1.4404 (AISI 316L)
 (3) 1.4305 (AISI 303)

 Materials in contact with fluid

| Component Materials in Contact with Fluid (continued) | | | | | | | | |
|---|------------|-----------------|-------|-------|---------|------|----------|-----------|
| Pressure switch catalog number | Zinc alloy | Stainless steel | Brass | Steel | Nitrile | PTFE | FPM, FKM | Aluminium |
| XMLB004A●●●● | | | | | | | | |
| XML●004B●●●●, XML●S04B●●●● | | | | | | | | |
| XML●004C●●●● | | (3) | | | | | | |
| XML●010A●●●● | | | | | | | | |
| XML●010B●●●● | | | | | | | | |
| XML●010C●●●● | | (2) | | | | | | |
| XML●010P●●●●, XML●S10A●●●● | | | | | | | | |
| XML●020A●●●●, XML●035A●●●● | | | | | | | | |
| XML●020B●●●●, XML●035B●●●● | | | | | | | | |
| XML●020C●●●●, XML●035C●●●● | | (2) | | | | | | |
| XML●020P●●●●, XML●035P●●●●, XML●S20A●●●● | | | | | | | | |
| XML●070D●●●●, XML●160D●●●● | | | | | | | | |
| XML●070E●●●●, XML●160E●●●● | | (4) | | | | | | |
| XML●070N●●●●, XML●160N●●●● | | (5) | | | | | | |
| XML●300D●●●● | | | | | | | | |
| XML●300E●●●● | | (4) | | | | | | |
| XML●300N●●●● | | (5) | | | | | | |
| XML●500D●●●● | | | | | | | | |
| XML●500E●●●● | | | | | | | | |
| XML●500N●●●●4 | | (5) | | | | | | |

Grade of Stainless Steel

- (1) 1.4307 (AISI 316L)
- (2) 1.4404 (AISI 316L)
- (3) 1.4305 (AISI 303)
- (4) 1.4404 (AISI 316L) + 1.4462
- (5) 1.4404 (AISI 316L) + 1.4305 (AISI 303)

 Materials in contact with fluid

9012G and 9016G industrial pressure and vacuum switches

9012G pressure switches

The 9012G pressure switches are UL Listed and CSA certified as industrial control equipment. They are used to interface pneumatic or hydraulic systems with electrical control systems by opening or closing electrical contacts in response to pressure changes in the system. They have outstanding repeatability and drift performance. Their efficient design uses durable, low mass components for excellent performance under heavy duty vibration and shock conditions.

The 9012G pressure switches line offers devices with either diaphragm or piston actuators—for optimum life, versatility, and speed of operation. Features include the following:

- High shock resistance
- High set-point stability
- Internal or external range adjustment
- No drain line required
- Dual numerical range scale (psi and kPa)
- One or two SPDT double-break contacts
- Adjustable or fixed (nonadjustable) differential
- Single-stage, dual-stage, or differential-pressure operation

A variety of modifications is available (see also page 69):

The 9012G diaphragm switches range from 0.2-675 psi falling pressure. Nitrile diaphragms and zinc-plated steel flanges are standard. Diaphragms of Viton® fluorocarbon or ethylene propylene are available as well as stainless steel flanges.

The 9012G piston-actuated switches range from 20-9,000 psi falling pressure. They have sealed pistons and can be used on air, water, oil, or any media compatible with the actuator material. The switches come standard with stainless steel pistons and housings, Viton diaphragms and O-ring seals, and Teflon® retaining rings. Ethylene propylene diaphragms and O-ring seals are also available.

The 9012G industrial pressure switches are available as open type or in NEMA 1 enclosures. The backplate is steel with a plastic cover. Open devices in pressure ranges up to 250 psi are available with internal- or external-threaded pressure connectors, ideally suiting them for panel mounting.

The 9012G machine tool pressure switches with NEMA 4, 4X, or 13 (IP66) cast aluminum enclosures are UL Listed and CSA certified as industrial control equipment. They are also UL Marine Listed for use on vessels greater than 65 ft long where ignition protection is not required.

The 9012G machine tool switches are also available in NEMA 7 & 9 cast aluminum enclosures. These are UL Listed for use in Class I, Divisions 1 and 2, Groups C and D, and Class II, Divisions 1 and 2, Groups E, F, G hazardous locations.

Application and general information

9012 pressure switches can generally be used in any application where electrical contacts must open or close in response to a system pressure change, within the electrical and pressure ratings of the switch. Pressure switches are used in a wide variety of applications such as the following:

- compressed air systems
- HVAC equipment
- chillers
- pumping systems
- machine tools
- stamping presses
- automatic grinders
- welders
- process equipment
- molding machines

Pressure switches typically perform one of the following two functions:

Monitoring the pressure in the system. The switch can be used either as an interlock that sequences operations in an automatic system, or to give an audio or visual signal, typically an alarm of an undesired condition, at predetermined pressures.

A switch with a **fixed** differential is generally used in these applications.

Controlling the pressure in the system by starting and stopping a pump or a compressor at predetermined pressures. A switch with an **adjustable** differential is usually needed in these applications.

9012G and 9016G industrial pressure and vacuum switches

9012G pressure switches

Diaphragm life

The elastomer diaphragms used on 9012G switches can withstand high speed cycling and wide pressure changes. They can tolerate operating speeds up to 200 cycles per minute with no negative impact on the life of the diaphragm.

Diaphragm life is affected by pressure medium compatibility. Standard diaphragms on 9012G devices are nitrile in zinc-plated steel flanges. Also available are Viton fluorocarbon and ethylene propylene diaphragms, as well as Type 316 stainless steel flanges.

The diaphragm can withstand wide pressure changes on each operating cycle. However, the pressure applied to the diaphragm during the normal operating cycle should never exceed the maximum value listed in the Range column in the catalog listing. Regularly cycling the pressure above this value reduces life considerably. If significant surges are common, or if pressures are higher than those listed in the Range column, consider using a piston device.

Piston life

For long piston life, the pressure medium should be filtered to keep foreign matter such as dirt and chips out of the piston assembly. 9012G sealed piston devices are not recommended for use on dry gas media, since this usage could cause some leakage past the seal. Depending on the gas, the media pressure, and the rate of operation, the amount of leakage could render the switch inoperable. (Note, however, that some weepage of the media is necessary to lubricate the seals. This small amount of weepage does not indicate a problem.)

Surges

One of the most destructive conditions for a pressure switch is hydraulic surge. A surge is a high rate of rise in pressure, normally of short duration, caused by starting a pump or by opening and closing a valve. Extremely high rates of rise in pressure can be damaging even if they are within the limits of the maximum allowable pressure.

To limit the effect of surges, the switch should be mounted as close to an accumulator and as far from the pump or quick acting valve as possible. The 9012G piston-actuated switches have a 0.020 in. pressure orifice to help reduce the effects of minor surges. 9012G diaphragm-actuated switches have a 0.060 in. pressure orifice. A restrictor with a small orifice placed in the line between the switch and the pump or valve will further help to protect the switch.

Vibration

Among other things, excessive vibration can cause contact bounce, chatter, or premature contact transfer, especially when system pressure is near the operating point of the switch. Remote mounting of the switch is the best way to avoid problems.

Use on steam

Switches should not be applied directly on steam exceeding 15 psig. However, with steam capillary tubing installed between the pressure connection and the switch, steam pressure up to 250 psig can be applied—provided this does not exceed the maximum allowable pressure rating of the switch or the maximum temperature rating at the actuator. Refer to the instruction bulletin supplied with the device.

Dual-stage operation

The 9012G dual-stage pressure switches provide two distinct levels of control from one device. These switches are most commonly used where dual functions are required, or in sequencing applications such as alarm-shutdowns.

Differential-pressure operation

The 9012G pressure switches for differential-pressure sensing can monitor changes in the difference between two pressures. These unidirectional devices signal that a predetermined pressure difference was reached, resulting from a widening or narrowing of the difference between two pressures.

Piston- vs. diaphragm-actuated devices

Whether to select a piston or diaphragm device depends on several criteria:

- maximum allowable pressure
- range and differential
- surges
- medium (whether hydraulic or pneumatic)

Maximum allowable pressures for piston devices are much higher than for diaphragm devices. Most diaphragm devices have a maximum allowable pressure of 850 psi or less, whereas all piston devices have a maximum allowable pressure of 10,000 psi or more.

Range and differential for diaphragm devices are lower than for piston devices. Many applications call for a low differential, such as 20 psi. This may exclude piston devices, which have a minimum differential of 60 psi or more.

Surges are a part of every hydraulic system. While many are small and have only a small effect on the switch, some are significant and can potentially destroy a pressure switch. Diaphragm devices are the most sensitive to surges and are most easily damaged. Piston devices are more tolerant of surges and last longer in the same application.

Hydraulic systems, which typically use oil-based media, are more demanding applications than pneumatic systems. Pressure switches used in hydraulic applications typically experience higher pressures, have wider pressure variations, and produce more surges, since the medium does not compress. Pneumatic systems, which typically use air, place fewer demands on a system, since these applications typically experience lower pressures and the medium can compress, cushioning the effects of surges. Table 1 offers basic guidelines for determining the selection of a piston- versus a diaphragm-operated pressure switch.

Piston vs. diaphragm

| | | |
|------------------------------------|--------------------------------|---------------------|
| Maximum allowable pressures | High | Piston |
| | Lower | Diaphragm |
| Pressures | High pressures | Piston |
| | Low differentials or pressures | Diaphragm |
| Surges | Constant | Piston |
| | Minimal | Diaphragm or piston |
| Media | Hydraulic systems | Piston |
| | Pneumatic systems | Diaphragm |

Operating points (set points)

Pressure switches have two operating points:

- Increasing pressure (rising pressure)
- Decreasing pressure (falling pressure)

These operating points are also called the set points of the switch.

Differential

The *differential* is the difference in pressure between the rising and falling pressure points. It can be adjustable or fixed.

Range

The *range* refers to the pressure limits within which the operating points (settings) can be adjusted. The range of the 9012G pressure switch is tied to the decreasing pressure operating point. Adding the differential to the decreasing pressure operating point determines the increasing pressure operating point.

Differential

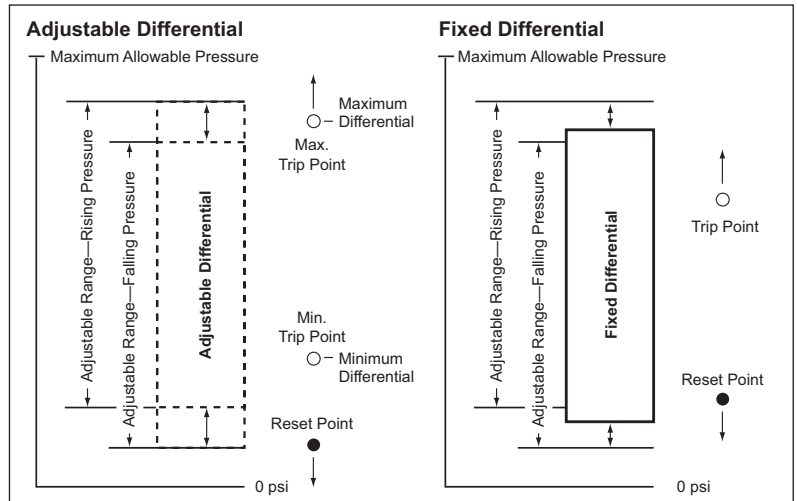

Fixed differential

To determine the operating range on rising pressure for a fixed differential switch, add the differential to the decreasing pressure operating point. For example, to determine the range on **increasing** pressure for a 9012GDW5 switch:

- Range on decreasing pressure = 3 to 150 psi
- Fixed differential = 6.0 ± 0.8 psi
- Range on increasing pressure = 9 ± 0.8 to 156 ± 0.8 psi

Adjustable differential

For adjustable differential switches, add the minimum differential to the low end of the range and the maximum differential to the high end of the range. For example, to determine the range on **increasing** pressure for a 9012GAW5:

- Range on decreasing pressure = 3 to 150 psi
- Adjustable differential = 6.0 to 30 psi
- Range on increasing pressure = 9 to 180 psi

During the normal operating cycle, system pressure should never exceed the upper limit of the range when using a diaphragm-actuated switch. This greatly reduces the life of the diaphragm. For optimum life, operate the switch in the middle 80% of the range.

Maximum allowable pressure

Maximum allowable pressure is the pressure to which a switch can be subjected without causing a change in operating characteristics, shift in settings, or damage to the device.

System pressure surges may occur during machine startup or from valve operation. Surges are not normally detrimental to the life of a switch if the surge is within the maximum allowable pressure rating of the switch. Diaphragm-actuated switches should not be subjected to more than 10 surges per day. More frequent surges greatly reduce the life of the diaphragm.

9012G and 9016G

Industrial pressure and vacuum switches

9012G pressure and 9016G vacuum switches

| Environment | |
|--|--|
| Environmental specifications | |
| Conformity to standards | CE, UKCA, IEC 60947.4.1, UL 508, CSA C22-2 n°14 |
| Product certifications | UL Listed and CSA certified as industrial control equipment |
| Protective treatment | Marine use: HT (does not apply to 9016GVG) |
| Fluids controlled | Air, water, hydraulic oils, gases, steam (depending on the model) |
| Materials | Cast aluminum enclosures (9012 NEMA 1 and 9016 GVG are stamped metal enclosure and molded cover) |
| Operating position | Operates in all positions |
| Shock resistance | 50 g |
| Degree of protection | Depends on the model |
| Operating rate (operating cycles/minute) | 120 operations/minute max. 9016GVG: 60 operations/minute max. |
| Repeat accuracy | ±2.0% (does not apply to 9016GVG) |
| Drift | ±1.0% of the adjustable range over 1 million operations |
| Pressure connection | G1/4 (BSP) female, 1/4"-18 NPTF, or 1/2"-14 NPT |
| Electrical connection | 1/2"-14 NPTF, Pg13.5, or ISO M20 (also, 3/4"-14 NPTF available only on NEMA 7 and 9). NEMA 1 is 1/2" conduit entry, unthreaded. |

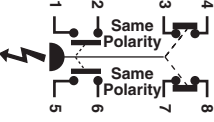
| Contact arrangement | | |
|---|---------------------|---|
| 9012G and 9016G machine tool and vacuum switches (except GVG) | | |
| Type | Contact arrangement | Contact symbol |
| Single Pole Double Throw (SPDT) | 1 N.O., 1 N.C. |  |
| Snap switch contains two double-break contact elements (1 N.O., 1 N.C.) that must be used on circuits of the same polarity. | | |
| Double Pole Double Throw (DPDT) | 2 N.O., 2 N.C. |  |
| Snap switch contains two electrically separated sets of contact elements allowing use on circuits of opposite polarity. Each set contains two double-break contact elements (1 N.O. and 1 N.C.) that must be used on circuits of the same polarity. | | |

| Circuit ratings | | | | | | | | | | |
|-----------------|-----------------------------|----------------|----------------------------|------|-------|-----|-----------------------------|----------------|-------------------------|--------------|
| Contacts | Continuous carrying amperes | AC—50 or 60 Hz | | | | | | DC | | |
| | | Voltage (V) | Inductive 35% power factor | | | | Resistive, 75% power factor | Voltage (V) | Inductive and resistive | |
| | | | Make | | Break | | | | Make and break amperes | |
| | | | A | VA | A | VA | | | Single throw | Double throw |
| SPDT | 10 | 120 | 60 | 7200 | 6 | 720 | 6 | 125 | 0.55 | 0.22 |
| | 10 | 240 | 30 | 7200 | 3 | 720 | 3 | 250 | 0.27 | 0.11 |
| | 10 | 480 | 15 | 7200 | 1.5 | 720 | 1.5 | 301-600 (1) | 0.10 | — |
| | — | 600 | 12 | 7200 | 1.2 | 720 | 1.2 | | | |
| DPDT | 10 | 120 | 60 | 7200 | 6 | 720 | 6 | 125 | 0.22 | 0.22 |
| | 10 | 240 | 30 | 7200 | 3 | 720 | 3 | 250 | 0.11 | 0.11 |
| | 10 | 480 | 15 | 7200 | 1.5 | 720 | 1.5 | 600 | — | — |
| | — | 600 | 12 | 7200 | 1.2 | 720 | 1.2 | — | — | — |

(1) Continuous carrying ampere rating does not apply.

Acceptable wire sizes: 12-22 AWG. Recommended terminal clamp torque: 7 lb-in
Not recommended for use on circuits below 24 V, 20 mA.

| Electrical Ratings—9016GVG | | | |
|----------------------------|--------------|-----------|--------|
| Voltage | AC | | DC |
| | Single Phase | Polyphase | |
| 110 V | 2 hp | 3 hp | 1 hp |
| 220 V | 3 hp | 5 hp | 1 hp |
| 440-550 V | 5 hp | 5 hp | — |
| 32 V | — | — | 0.5 hp |

Note: Control Circuit Rating: A600

| Interpreting the commercial reference (excluding 9016GVG) | | | | 9012G A R 2 2 | | | | |
|--|---------------------------------------|--------------------------------------|---------|----------------------|-------|-------|-----------------------------------|---|
| Use this table for interpretation only. Some combinations are not available. | | | | Commercial reference | | | | |
| Designation | | | | 9012G | | | | |
| Classification | Pressure Switch | | | | | | | |
| | Vacuum Switch | | | 9016G | | | | |
| Actuator Type— Differential Type | Single-Stage Machine Tool | Diaphragm, Low Pressure—Adjustable | | A | | | | |
| | | Diaphragm, High Pressure—Adjustable | | B | | | | |
| | | Piston—Adjustable | | C | | | | |
| | | Diaphragm, Low Pressure—Fixed | | D | | | | |
| | | Diaphragm, High Pressure—Fixed | | E | | | | |
| | | Piston—Fixed | | F | | | | |
| | Differential-Pressure | Diaphragm, Low Pressure—Adjustable | | G | | | | |
| | | Diaphragm, High Pressure—Adjustable | | H | | | | |
| | | Piston—Adjustable | | J | | | | |
| | Dual-Stage | Diaphragm, Low Pressure—Adjustable | | K | | | | |
| | | Diaphragm, High Pressure—Adjustable | | L | | | | |
| | | Piston—Adjustable | | M | | | | |
| | Single-Stage Industrial | Diaphragm, Low Pressure—Adjustable | | N | | | | |
| | | Diaphragm, High Pressure—Adjustable | | P | | | | |
| | | Piston—Adjustable | | Q | | | | |
| | | Diaphragm, Low Pressure—Fixed | | R | | | | |
| Diaphragm, High Pressure—Fixed | | | S | | | | | |
| Enclosure, NEMA Type | 1 | | | G | | | | |
| | Open | | | O | | | | |
| | 7, 9 | | | R | | | | |
| | 4, 4X, 13 | | | W | | | | |
| Threads | 1/4"-18 NPTF | | | | blank | | | |
| | Metric | | | | M | | | |
| Contacts | Single-pole, double-throw | | | | | blank | | |
| | Double-pole, double-throw | | | | | 2 | | |
| Pressure Range (psi) | Diaphragm | Single or Dual Stage, Low Pressure | 0.2-10 | | | | 1 | |
| | | | 1-40 | | | | 2 | |
| | | Single or Dual Stage, High Pressure | 1.5-75 | | | | | 4 |
| | | | 3-150 | | | | | 5 |
| | | | 5-250 | | | | | 6 |
| | | | 13-425 | | | | | 1 |
| | Piston | Single or Dual Stage | 20-675 | | | | 2 | |
| | | | 0-75 | | | | 1 | |
| | | | 0-175 | | | | 4 | |
| | | Differential-Pressure, High Pressure | 0-500 | | | | | 1 |
| | | | 20-1000 | | | | | 1 |
| | | | 90-2900 | | | | | 2 |
| Differential-Pressure | Single or Dual Stage | 170-5600 | | | | 3 | | |
| | | 270-9000 | | | | 4 | | |
| | | 0-5000 | | | | 1 | | |
| Vacuum (inHg) | Diaphragm | Single Stage, Low Pressure | 0-28 | | | | 1 | |
| | | | 0-25 | | | | 2 | |
| Options | Factory modifications and accessories | | | | | | See tables on pages 75, 77 and 83 | |

9012G machine tool pressure switches for single-stage operation Pressure range (psi)—Contacts change on decreasing pressure

| Actuator | Switch style | Range (psi) | Fixed differential | Adjustable differential | Pressure code | |
|-----------|---------------------------------------|--------------------------------------|--------------------|-------------------------|---------------|---|
| Diaphragm | Single or Dual Stage, Low Pressure | 0.2-10 | 0.6±0.1 | 0.6-2 | 1 | |
| | | 1-40 | 1.6±0.4 | 1.6-8 | 2 | |
| | | 1.5-75 | 3.0±0.5 | 3.5-15 | 4 | |
| | | 3-150 | 6.0±0.8 | 6.0-30.0 | 5 | |
| | | 5-250 | 10.0±1.5 | 10.0-49 | 6 | |
| | | 13-425 | 16±3.5 | 16-90 | 1 | |
| | Single or Dual Stage, High Pressure | 20-675 | 27±5 | 27-130 | 2 | |
| | | Differential-Pressure, Low Pressure | 0-75 | 0.25±10 | 0.25-10 | 1 |
| | | | 0-175 | — | 0.5-36 | 4 |
| | | Differential-Pressure, High Pressure | 0-500 | — | 3-175 | 1 |
| Piston | Single or Dual Stage | 20-1000 | 89±18 | 89-200 | 1 | |
| | | 90-2900 | 255±30 | 255-560 | 2 | |
| | | 170-5600 | 578±110 | 578-1260 | 3 | |
| | | 270-9000 | 788±140 | 788-1900 | 4 | |
| | Differential-Pressure | 0-5000 | — | 15-825 | 1 | |

The 9012G single-stage pressure switches are control-circuit rated devices. These switches are used in pneumatic or hydraulic systems on a wide variety of machine and process applications to protect the equipment. They either control or monitor the system pressure.

9012G and 9016G industrial pressure and vacuum switches

9012G machine tool pressure switches



9012GDW1

Single-Stage Operation

Class 9012 single-stage pressure switches are control circuit rated devices used in pneumatic or hydraulic systems on a wide variety of machine and process applications to protect the equipment and control or monitor the system pressure.

- Type G machine tool switches are available with NEMA 4, 4X, and 13 (IEC IP66) enclosure ratings.
- The NEMA 7 and 9 devices are UL listed for use in the following hazardous locations: Class I, Divisions 1 and 2, Groups C and D; and Class II, Divisions 1 and 2, Groups E, F, and G.
- NEMA 4, 4X, and 13 devices are suitable for use in Class I, Division 2, Groups A, B, C, and D hazardous locations or nonhazardous locations only.
- Enclosure materials are cast aluminum.
- To ensure repeatability and minimize setting drift, pressure settings should fall within the middle 80 percent of the pressure range.

Fixed differential NEMA 4, 4X, 13 Enclosure

UL Listed and CSA Certified as Industrial Control Equipment

| Range on decreasing pressure psig | Approximate differential at mid-range, psig (1) | Maximum allowable pressure, psig | Class 9012 Type | |
|---|---|----------------------------------|-----------------|-----------|
| | | | SPDT | DPDT |
| Diaphragm actuated—Nitrile diaphragm, zinc plated steel housing | | | | |
| 0.2-10 | 0.6 ± 0.1 | 100 | 9012GDW1 | — |
| 1-40 | 1.6 ± 0.4 | 100 | 9012GDW2 | 9012GDW22 |
| 1.5-75 | 3.0 ± 0.5 | 240 | 9012GDW4 | — |
| 3-150 | 6.0 ± 0.8 | 475 | 9012GDW5 | 9012GDW25 |
| 5-250 | 10.0 ± 1.5 | 750 | 9012GDW6 | — |
| 13-425 | 16 ± 3.5 | 850 | 9012GEW1 | — |
| 20-675 | 27 ± 5 | 2000 | 9012GEW2 | — |
| Piston actuated—#440 stainless steel piston #303 stainless steel housing, Viton® fluorocarbon diaphragm and O-ring, Teflon® retaining ring | | | | |
| 20-1000 | 59 ± 9 | 10,000 | 9012GFW1 | — |
| 90-2900 | 170 ± 15 | 15,000 | 9012GFW2 | 9012GFW22 |
| 170-5600 | 289 ± 55 | 20,000 | 9012GFW3 | — |

Specifications

| | | |
|-------------------------------|---|-------------------|
| Fluids controlled | Air, water, hydraulic oils, gases, steam (depending on the model) | |
| Pressure connection | 1/4"-18 NPTF is standard. For metric threads, add M after the W on all types (2). Other options are available (see page 75). | |
| Weight (approximate) | 3 lb (1.36 kg) | |
| Voltage limits | 600 V | |
| Continuous current | 10 A | |
| Electrical connections | 1/2"-14 NPTF (standard), For Pg 13.5, or ISO M20, see footnote (2). | |
| Standards/Ratings | CE, UKCA, IEC 60947.4.1, UL 508, CSA C22-2 n°14. UL Marine Listed for use on ships/vessels greater than 65 ft long where ignition protection is not required. | |
| Temperature ratings | Minimum | Maximum |
| Ambient | -23 °C (-10 °F) | +85 °C (+185 °F) |
| Media | Diaphragm -40 °C (-40 °F) | +120 °C (+250 °F) |
| | Piston -26 °C (-15 °F) | |
| | All with Form Q4 -26 °C (-15 °F) | |

Operating curves

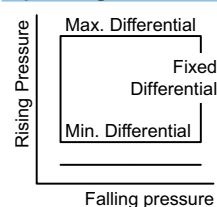

Contact blocks

1 N.O., 1 N.C.



2 N.O., 2 N.C.

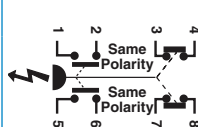

Connection

Form H17

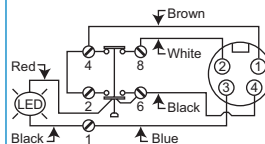

Form H10

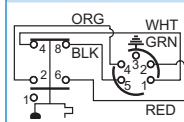

Form H11

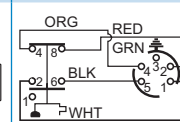

SPDT snap switches contain two double-break contact elements (1 N.O., 1 N.C.) that must be used on circuits of the same polarity. **DPDT** snap switches contain two electrically separated sets of contact elements allowing use on circuits of opposite polarity. Each set contains two double-break contact elements (1 N.O., 1 N.C.) that must be used on circuits of the same polarity.

Acceptable wire sizes: 12-22 AWG **Recommended terminal clamp torque:** 7 lb-in

- (1) The differential adds to the range setting and determines the operating point on rising pressure.
- (2) To order a Pg13.5 electrical conduit entry and a 1/4"-19 BSP pressure connection, add M12 to the end of the commercial reference, as well as adding "M" after "W" for metric threads. For example:
9012GAW1 = 1/2" NPT electrical conduit entry
9012GAWM1 = 20 x 1.5 mm electrical conduit entry and 1/4"-19 BSP pressure connection
9012GAWM1M12 = Pg13.5 electrical conduit entry and 1/4"-19 BSP pressure connection

9012G and 9016G industrial pressure and vacuum switches

9012G machine tool pressure switches



9012GAW1



9012GAW5G18

Adjustable Differential NEMA 4, 4X, 13 Enclosure UL Listed and CSA Certified as Industrial Control Equipment

| Range on Decreasing Pressure, psig | Adjustable Differential (1) Approximate at Mid Range | Maximum Allowable Pressure, psig | Class 9012 Type | |
|--|--|----------------------------------|-----------------|-----------|
| | | | SPDT | DPDT |
| Diaphragm Actuated—Nitrile Diaphragm, Zinc Plated Steel Housing | | | | |
| 0.2-10 | 0.7-2 | 100 | 9012GAW1 | 9012GAW21 |
| 1-40 | 2.4-8 | 100 | 9012GAW2 | 9012GAW22 |
| 1.5-75 | 3.9-15 | 240 | 9012GAW4 | 9012GAW24 |
| 3-150 | 6.6-30 | 475 | 9012GAW5 | 9012GAW25 |
| 5-250 | 11-49 | 750 | 9012GAW6 | 9012GAW26 |
| 13-425 | 20-82 | 850 | 9012GBW1 | 9012GBW21 |
| 20-675 | 35-130 | 2000 | 9012GBW2 | 9012GBW22 |

Piston Actuated—#440 Stainless Steel Piston. #303 Stainless Steel Housing, Viton® Fluorocarbon Diaphragm and O-ring, Teflon® Retaining Ring

| | | | | |
|----------|----------|--------|----------|-----------|
| 20-1000 | 65-200 | 10,000 | 9012GCW1 | 9012GCW21 |
| 90-2900 | 187-560 | 15,000 | 9012GCW2 | 9012GCW22 |
| 170-5600 | 425-1050 | 20,000 | 9012GCW3 | 9012GCW23 |
| 270-9000 | 580-1500 | 25,000 | — | 9012GCW24 |

Specifications

| | |
|-------------------------------|--|
| Fluids Controlled | Air, water, hydraulic oils, gases, steam (depending on the model) |
| Pressure Connection | 1/4"-18 NPTF is standard. For metric threads (G1/4 BSP female pressure connection and M20 electrical connection), add M after the W in the commercial reference. For additional pressure connections, see page 75 (1). |
| Weight (approximate) | 3 lb (1.36 kg) |
| Voltage Limits | 600 V |
| Continuous Current | 10 A |
| Electrical Connections | 1/2"-14 NPTF is standard. For metric threads (G1/4 BSP female pressure connection and M20 electrical connection), add M after the W in the commercial reference (2). |
| Standards/Ratings | CE, UKCA, IEC 60947.4.1, UL 508, CSA C22-2 n°14. UL Marine Listed for use on ships/vessels greater than 65 ft long where ignition protection is not required. |

| Temperature Ratings | | Minimum | Maximum |
|---------------------|------------------|-----------------|-------------------|
| Ambient | | -23 °C (-10 °F) | +85 °C (+185 °F) |
| | Diaphragm | -40 °C (-40 °F) | +120 °C (+250 °F) |
| Media | Piston | -26 °C (-15 °F) | |
| | All with Form Q4 | -26 °C (-15 °F) | |

| Operating Curves | Contact Blocks | Connection |
|---|---|--|
| <p>Rising Pressure</p> <p>Max. Differential</p> <p>Adjustable Differential</p> <p>Min. Differential</p> <p>Falling pressure</p> | <p>1 N.O., 1 N.C.</p> <p>2 N.O., 2 N.C.</p> | <p>Form H17</p> <p>Form H10</p> <p>Form H11</p> |

SPDT snap switches contain two double-break contact elements (1 N.O., 1 N.C.) that must be used on circuits of the same polarity.
DPDT snap switches contain two electrically separated sets of contact elements allowing use on circuits of opposite polarity. Each set contains two double-break contact elements (1 N.O., 1 N.C.) that must be used on circuits of the same polarity.

| | | | |
|-------------------------------|-----------|---|---------|
| Acceptable Wire Sizes: | 12-22 AWG | Recommended Terminal Clamp Torque: | 7 lb-in |
|-------------------------------|-----------|---|---------|

(1) The differential adds to the range setting and determines the operating point on rising pressure.
 (2) To order a Pg13.5 electrical conduit entry and a 1/4"-19 BSP pressure connection, add M12 to the end of the commercial reference, as well as adding "M" after "W" for metric threads. For example:
 9012GAW1 = 1/2" NPT electrical conduit entry
 9012GAWM1 = 20 x 1.5 mm electrical conduit entry and 1/4"-19 BSP pressure connection
 9012GAWM1M12 = Pg13.5 electrical conduit entry and 1/4"-19 BSP pressure connection

Photo-electric sensors

XUM, general purpose, single mode function

Miniature design, plastic

Three-wire DC, solid-state output

Potentiometer setting for NO/NC, sensitivity



9012GAR4

Adjustable Differential
NEMA 7 & 9 Enclosure, Class I & II, Division 1 & 2, Groups C, D, E, F, G
UL Listed as Industrial Control Equipment

| Range on Decreasing Pressure, psig | Adjustable Differential (1) Approximate at Mid Range | Maximum Allowable Pressure, psig | Class 9012 Type SPDT | DPDT |
|--|--|----------------------------------|----------------------|-----------|
| Diaphragm Actuated—Nitrile Diaphragm, Zinc Plated Steel Housing | | | | |
| 1.5-75 | 8-15 | 240 | 9012GAR4 | 9012GAR24 |
| 3-150 | 16-30 | 475 | 9012GAR5 | 9012GAR25 |
| 5-250 | 23-49 | 750 | 9012GAR6 | — |
| 13-425 | 36-82 | 850 | 9012GBR1 | — |

| Piston Actuated—#440 Stainless Steel Piston. #303 Stainless Steel Housing, Viton® Fluorocarbon Diaphragm and O-ring, Teflon® Retaining Ring | | | | |
|--|----------|--------|----------|---|
| 90-2900 | 281-560 | 15,000 | 9012GCR2 | — |
| 170-5600 | 638-1050 | 20,000 | 9012GCR3 | — |

Specifications

| | | | | |
|-------------------------------|---|--|--|--|
| Fluids Controlled | Air, water, hydraulic oils, gases, steam (depending on the model) | | | |
| Pressure Connection | 1/4"-18 NPTF (standard) or 1/2"-14 NPT. See page 75. | | | |
| Weight (approximate) | 10 lb (4.54 kg) | | | |
| Voltage Limits | 600 V | | | |
| Continuous Current | 10 A | | | |
| Electrical Connections | 1/2"-14 NPTF, 3/4"-14 NPTF | | | |
| Standards/Ratings | CE, UKCA, IEC 60947.4.1, UL 508, CSA C22-2 n°14. UL Marine Listed for use on vessels longer than 65 ft where ignition protection is required. | | | |

| Temperature Ratings | Minimum | | Maximum | |
|---------------------|------------------|-----------------|---------|-------------------|
| | Ambient | -23 °C (-10 °F) | | +85 °C (+185 °F) |
| Media | Diaphragm | -40 °C (-40 °F) | | +120 °C (+250 °F) |
| | Piston | -26 °C (-15 °F) | | |
| | All with Form Q4 | -26 °C (-15 °F) | | |

Operating Curves **Contact Blocks** **Connection**

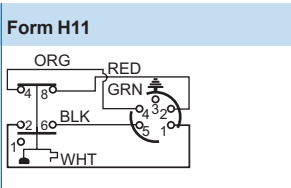
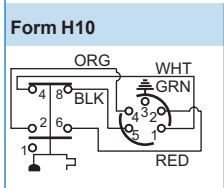
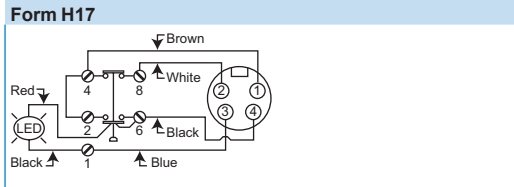
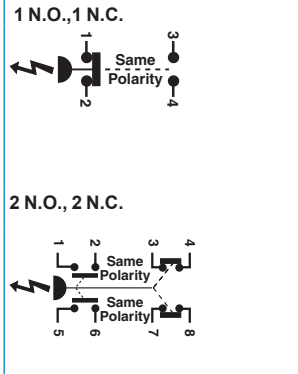
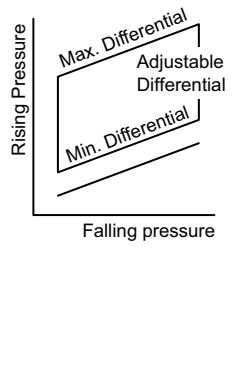

SPDT snap switches contain two double-break contact elements (1 N.O., 1 N.C.) that must be used on circuits of the same polarity. **DPDT** snap switches contain two electrically separated sets of contact elements allowing use on circuits of opposite polarity. Each set contains two double-break contact elements (1 N.O., 1 N.C.) that must be used on circuits of the same polarity.

Acceptable Wire Sizes: 12-22 AWG **Recommended Terminal Clamp Torque:** 7 lb-in

(1) The differential adds to the range setting and determines the operating point on rising pressure.



9012G and 9016G industrial pressure and vacuum switches

9012G pressure switches for differential-pressure operation



9012GJW1

Differential-Pressure Operation

Pressure switches for differential-pressure operation are used to monitor the change in the difference between two pressures. The 9012G differential-pressure switches are unidirectional devices and are used in applications to signal that a predetermined pressure difference has been reached as a result of a widening or increasing difference between the two pressures. They can also be used in applications to signal that a predetermined pressure difference has been reached as a result of a narrowing or decreasing difference between the two pressures.

NEMA 4, 4X, and 13 devices are suitable for use in Class I, Division 2, Groups A, B, C, and D hazardous locations or nonhazardous locations only.

Adjustable differential NEMA 4, 4X, 13 Enclosures UL Listed and CSA Certified as Industrial Control Equipment

| Working Pressure Range on decreasing X (upper) actuator | Adjustable Difference on Decreasing Pressure (Adds to working pressure) Y (lower) actuator | Adjustable Differential Actuates on increasing pressure (adds to adjustable difference) | Maximum Allowable Pressure | Class 9012 Type | |
|---|---|--|----------------------------------|-----------------|------|
| | | | | SPDT | DPDT |

| Diaphragm Actuated—Nitrile Diaphragm, Zinc Plated Steel Housing | | | | | |
|---|---------|--------|-----|----------|-----------|
| 0-75 | 0.25-10 | 1-2 | 100 | 9012GGW1 | 9012GGW21 |
| 0-175 | 0.5-36 | 5.6-15 | 240 | 9012GGW4 | 9012GGW24 |
| 0-500 | 3-175 | 26-90 | 850 | 9012GHW1 | 9012GHW21 |

Specifications

| | | |
|-------------------------------|--|--|
| Fluids Controlled | Air, water, hydraulic oils, gases, steam (depending on the model) | |
| Pressure Connection | 1/4"-18 NPTF is standard. For metric threads (G1/4 BSP female pressure connection and M20 electrical connection), add M after the W in the commercial reference. For other options, see page 75 (1). | |
| Weight (approximate) | 3 lb (1.36 kg) | |
| Voltage Limits | 600 V | |
| Continuous Current | 10 A | |
| Electrical Connections | 1/2"-14 NPTF (standard), For Pg 13.5, or ISO M20, see footnote (2) on page 72. | |
| Standards/Ratings | CE, UKCA, IEC 60947.4.1, UL 508, CSA C22-2 n°14. UL Marine Listed for use on vessels greater than 65 ft long where ignition protection is not required. | |

| | Temperature Ratings | |
|----------------|---------------------|------------------|
| | Minimum | Maximum |
| Ambient | -23 °C (-10 °F) | +85 °C (+185 °F) |
| Media | Diaphragm | -40 °C (-40 °F) |
| | Piston | -26 °C (-15 °F) |
| | All with Form Q4 | -26 °C (-15 °F) |

| Operating Curves | Connection |
|------------------|------------|
| | |

SPDT snap switches contain two double-break contact elements (1 N.O., 1 N.C.) that must be used on circuits of the same polarity.
DPDT snap switches contain two electrically separated sets of contact elements allowing use on circuits of opposite polarity. Each set contains two double-break contact elements (1 N.O., 1 N.C.) that must be used on circuits of the same polarity.

| | | | |
|-------------------------------|-----------|---|---------|
| Acceptable Wire Sizes: | 12-22 AWG | Recommended Terminal Clamp Torque: | 7 lb-in |
|-------------------------------|-----------|---|---------|



Listed Marine Use



Certified Class 3211-03





9012GKW2

Dual-Stage Operation

The **9012G dual-stage pressure switches** are designed for use in applications where two separate pressure operations must be controlled by a single pressure monitoring device. These controls are most commonly used where dual functions are required or in sequencing applications such as alarm shutdowns. The spread between the two stages is adjustable, but the differential between the high (rising) and low (falling) operating points of each stage is fixed.

NEMA 4, 4X, and 13 devices are suitable for use in Class I, Division 2, Groups A, B, C, and D hazardous locations or nonhazardous locations only.

Fixed Differential NEMA 4, 4X, 13 Enclosure UL Listed and CSA Certified as Industrial Control Equipment

| Range Setting | Adjustable Spread | Fixed Differential | | Maximum Allowable Pressure | SPDT Each Stage |
|---|--|--------------------|-----------|----------------------------|-----------------|
| | | Stage 1 | Stage 2 | | |
| Pressure limits between which Stage 1 can be adjusted to operate on decreasing pressure | Add to the range setting to obtain the decreasing operating point of Stage 2 | 4.0 ± 1.0 | 6.0 ± 1.5 | 100 | 9012GKW2 |
| | | 6.0 ± 1.5 | 8.0 ± 2.0 | 240 | 9012GKW4 |
| | | 8.0 ± 2.0 | 12 ± 3 | 475 | 9012GKW5 |
| | | 14 ± 3 | 21 ± 5 | 750 | 9012GKW6 |

| Diaphragm Actuated—Nitrile Diaphragm, Zinc Plated Steel Housing | | | | | |
|---|----------|-----------|-----------|-----|----------|
| 1-40 | 4.4-20 | 4.0 ± 1.0 | 6.0 ± 1.5 | 100 | 9012GKW2 |
| 1.5-75 | 6.6-30 | 6.0 ± 1.5 | 8.0 ± 2.0 | 240 | 9012GKW4 |
| 3-150 | 13.2-75 | 8.0 ± 2.0 | 12 ± 3 | 475 | 9012GKW5 |
| 5-250 | 24.2-110 | 14 ± 3 | 21 ± 5 | 750 | 9012GKW6 |

| Piston Actuated—#440 Stainless Steel Piston. #303 Stainless Steel Housing, Viton® Fluorocarbon Diaphragm and O-ring, Teflon® Retaining Ring | | | | | |
|--|----------|----------|-----------|--------|----------|
| 90-2900 | 176-800 | 140 ± 30 | 210 ± 52 | 15,000 | 9012GMW2 |
| 170-5600 | 360-1700 | 275 ± 60 | 400 ± 100 | 20,000 | 9012GMW3 |

Specifications

| | |
|-------------------------------|---|
| Fluids Controlled | Air, water, hydraulic oils, gases, steam (depending on the model) |
| Pressure Connection | 1/4"-18 NPTF is standard. For metric threads, add M after the W on all types. Other options are available (see page 75). (1) |
| Weight (approximate) | 3 lb (1.36 kg) |
| Voltage Limits | 600 V |
| Continuous Current | 10 A |
| Electrical Connections | 1/2"-14 NPTF (standard), For Pg 13.5, or ISO M20, see footnote (2) on page 7. |
| Standards/Ratings | CE, UKCA, IEC 60947.4.1, UL 508, CSA C22-2 n°14. UL Marine Listed for use on vessels greater than 65 ft long where ignition protection is not required. |

| Temperature Ratings | Minimum | | Maximum | |
|---------------------|------------------|-----------------|---------|-------------------|
| | Ambient | -23 °C (-10 °F) | | +85 °C (+185 °F) |
| Media | Diaphragm | -40 °C (-40 °F) | | +120 °C (+250 °F) |
| | Piston | -26 °C (-15 °F) | | |
| | All with Form Q4 | -26 °C (-15 °F) | | |

| Operating Curves | Contact Blocks | Acceptable Wire Sizes: |
|------------------|-------------------------------|---|
| | 1 N.O., 1 N.C. | 12-22 AWG Recommended Terminal Clamp Torque: 7 lb-in |



Listed Marine Use



Certified Class 3211-03



Wiring Diagrams for Receptacles and Connectors. Factory Modifications (Forms).

Prewired 5-pin male receptacle

Form H10

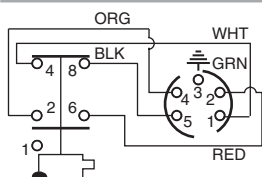

Form H11

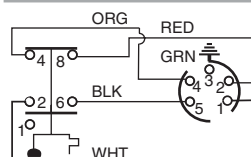

Micro connector, 4-pin, for 24 Vdc pilot light

Form H17

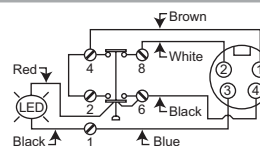

Modifications, Renewal Parts, and Accessories

9012G Machine Tool Factory Modifications (Forms)

| Modification | Applies to | Form | |
|---|--|---|-----|
| Lock on rising pressure, manual reset only | Available on GDW, GDWM, GEW, GEWM, GFW, GFWM only | E3 | |
| 120 Vac or Vdc neon pilot light | Available on all GAW-GMW and GAWM-GFWM | clear lens G17 red lens G18 | |
| | For pilot light conversion kits: See 9998PC306-308 | clear lens G21 red lens G22 | |
| 24 Vdc only LED | | Class 9012 GAW-GMW and GAWM-GFWM, or Class 9016 GAW | G23 |
| SPDT snap switch rated 1.1 A at 125 Vdc (minimum differential doubles) | Available on GAR-GFR, GAW-GJW, and GAWM-GFWM | H3 | |
| Prewired 5-pin male receptacle: Brad Harrison #41310 or interchangeable Crouse-Hinds receptacle at our convenience. For use with Brad Harrison female portable plug #41306, 41307, 41308 or equal | Available on GAW-GJW single pole devices only. See wiring diagrams on page 80. | H10 or H11 | |
| Micro connector, 4-pin, for 24 Vdc pilot light (see diagram on page 80) | G•W (single pole only), except GAW2 and Form B2. | H17 | |
| External range adjustment with range scale window | With knob | GAW-GFW, GAWM-GFWM, and GKW-GMW | K |
| | Slotted for screwdriver | GAW-GFW, GAWM-GFWM, and GKW-GMW | K1 |
| Pg 13.5 conduit thread and 1/4"-19 BSP pressure connection | GAW-GFW and GKW-GMW | M12 | |
| #316 stainless steel flange | Standard nitrile diaphragm | GAR, GBR, GDR, GER, GAW, GBW, GDW, GEW, GGW, GHW, GAWM, GBWM, GDWM, GEWM, GKW, GLW, except Types 1 and 21 | Q1 |
| | Ethylene propylene diaphragm | Available on all GGW, GHW except GGW-1, 21. Available on all GAR, GBR, GDR, GER, GAW, GBW, GDW, GEW, GAWM, GBWM, GDWM, GEWM, GKW, GLW, except Types 1 and 21 | Q3 |
| | Viton® fluorocarbon diaphragm | GAR, GAW, GBR, GBW, GDR, GDW, GER, GEW, GGW, GHW, GAWM, GBWM, GDWM, GEWM, GKW, GLW, except Types 1 and 21 | Q4 |
| Range scale window (standard with Forms K and K1) | GAW-GMW, GAWM-GFWM | V1 | |
| Special factory setting specified (If indicating only one special setting, specify whether this setting is on increasing or decreasing pressure.) | All 9012G | Y1 | |
| Pressure connection Not available in combination with Forms Q1, Q3, Q4 | 1/4"-18 NPT external thread | GAR, GAW, GDR, GDW, GGW, GKW | Z |
| | 1/2"-14 NPT external thread, 1/4"-18 NPTF internal thread | GAR, GAW, GDR, GDW, GGW, GKW | Z16 |
| | 7/16"-20 UNF-2B internal thread | GAR-GFR; GAW-GMW | Z18 |
| | | | |

9012G Pressure Switches, Factory Modifications (Forms) for Renewal Parts Kits, Class 9998

For suffixes for renewal parts kits, see the table below.

| Modification | Applies to Parts Kit Type | Form | |
|--|--|-----------------------|-----|
| SPDT snap switch rated 1.1 A at 125 Vdc (minimum differential doubles) | PC313 | H3 | |
| #316 stainless steel flange | Standard nitrile diaphragm | PC177-179, PC268, 269 | Q1 |
| | | PC265-267 | |
| | Ethylene propylene diaphragm | PC177-178, PC268, 269 | Q3 |
| | | PC266, 267 | |
| | Viton® fluorocarbon diaphragm | PC177-178, PC268, 269 | Q4 |
| | | PC265-267 | |
| Pressure connection | 1/4"-18 NPT external thread | PC265-269 | Z |
| | 1/2"-14 NPT external thread, 1/4"-18 NPTF internal thread | PC265-269 | Z16 |
| | 7/16"-20 UNF-2B internal thread | PC177, 178, PC265-273 | Z18 |
| | | | |



9012GRG5

| Fixed Differential Open Type or NEMA 1 Enclosure UL Listed and CSA Certified as Industrial Control Equipment | | | | |
|--|---|----------------------------------|--|----------|
| Range on Decreasing Pressure, psig | Approximate Differential (1) At Mid Range, psig | Maximum Allowable Pressure, psig | Class 9012 Type Open Type NEMA 1 | |
| Diaphragm Actuated—Nitrile Diaphragm, Zinc Plated Steel Housing | | | | |
| 1.5-75 | 2.2 ± 0.4 | 240 | 9012GRO4 | 9012GRG4 |
| 3-150 | 4.2 ± 1 | 475 | – | 9012GRG5 |
| Piston Actuated—#440 Stainless Steel Piston. #303 Stainless Steel Housing, Viton® Fluorocarbon Diaphragm and O-Ring, Teflon® Retaining Ring | | | | |
| 20-1000 | 49 ± 10 | 10,000 | – | 9012GTG1 |
| Specifications | | | | |
| Fluids Controlled | Air, water, hydraulic oils, gases, steam (depending on the model) | | | |
| Pressure Connection | 1/4"-18 NPTF (standard), 1/2"-14 NPT, or 7/16"-20 UNF-2B. See Forms table on page 77. | | | |
| Weight (approximate) | Type 1: 2 lb (0.91 kg); Open: 1.7 lb (0.77) | | | |
| Voltage Limits | 600 V | | | |
| Continuous Current | 10 A | | | |
| Electrical Connections | 1/2" conduit entry, unthreaded | | | |
| Standards/Ratings | CE, UKCA, IEC 60947.4.1, UL 508, CSA C22-2 n°14 | | | |
| Temperature Ratings | Minimum | Maximum | | |
| Ambient | -23 °C (-10 °F) | +85 °C (+185 °F) | | |
| Media | Diaphragm | +120 °C (+250 °F) | | |
| | Piston | | | |
| | All with Form Q4 | | | |
| Operating Curves | Contact Blocks | | | |
| | SPDT Form C contacts | | Acceptable Wire Sizes: 12-22 AWG Recommended Terminal Clamp Torque: 7 lb-in | |

(1) Determines the operating point on rising pressure.



Certified Class 3211-03



9012GNO5



9012GNG1

Adjustable Differential
Open Type or NEMA 1 Enclosure
UL Listed and CSA Certified as Industrial Control Equipment

| Range on Decreasing Pressure psig | Approximate Mid Range (1) | Maximum Allowable Pressure psig | Class 9012 Type | |
|-----------------------------------|---------------------------|---------------------------------|-----------------|--------|
| | | | Open Type | NEMA 1 |

| Diaphragm Actuated—Nitrile Diaphragm, Zinc Plated Steel Housing | | | | |
|---|----------|------|----------|----------|
| 0.2-10 | 0.6-1.0 | 100 | – | 9012GNG1 |
| 1-40 | 1.6-5.0 | 100 | – | 9012GNG3 |
| 1.5-75 | 2.5-6.5 | 240 | 9012GNO4 | 9012GNG4 |
| 3-150 | 4.8-13 | 475 | 9012GNO5 | 9012GNG5 |
| 5-250 | 8.5-20.5 | 750 | 9012GNO6 | 9012GNG6 |
| 13-425 | 20-41 | 850 | – | 9012GPG1 |
| 20-675 | 35-66 | 2000 | – | 9012GPG2 |

Piston Actuated—#440 Stainless Steel Piston.
#303 Stainless Steel Housing, Viton® Fluorocarbon Diaphragm and O-Ring, Teflon® Retaining Ring

| | | | | |
|----------|---------|--------|---|----------|
| 20-1000 | 56-98 | 10,000 | – | 9012GQG1 |
| 90-2900 | 162-308 | 15,000 | – | 9012GQG2 |
| 170-5600 | 355-563 | 20,000 | – | 9012GQG3 |

Specifications

| | | | | |
|-------------------------------|---|--|--|--|
| Fluids Controlled | Air, water, hydraulic oils, gases, steam (depending on the model) | | | |
| Pressure Connection | 1/4"-18 NPTF (standard), G1/4 (BSP) female, or 1/2"-14 NPT. See Forms in the table below. | | | |
| Weight (approximate) | Type 1: 2 lb (0.91 kg); Open: 1.7 lb (0.77) | | | |
| Voltage Limits | 600 V | | | |
| Continuous Current | 10 A | | | |
| Electrical Connections | 1/2" conduit entry, unthreaded | | | |
| Standards/Ratings | CE, UKCA, IEC 60947.4.1, UL 508, CSA C22-2 n°14 | | | |

| | Temperature Ratings | |
|----------------|---------------------|-------------------|
| | Minimum | Maximum |
| Ambient | -23 °C (-10 °F) | +85 °C (+185 °F) |
| Diaphragm | -40 °C (-40 °F) | +120 °C (+250 °F) |
| Media | Piston | -26 °C (-15 °F) |
| | All with Form Q4 | -26 °C (-15 °F) |

Operating Curves **Contact Blocks**

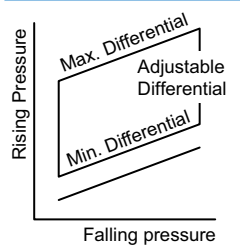

| | |
|---|-------------------------------------|
| SPDT Form C contacts | Acceptable Wire Sizes: 12-22 AWG |
| | |
| Recommended Terminal Clamp Torque: 7 lb-in | |

(1) Determines the operating point on rising pressure.

Factory Modifications (Forms) for 9012G Pressure Switches, Open Type or NEMA 1
UL Listed and CSA Certified as Industrial Control Equipment

| Modification | Applies to | Form | |
|---------------------|--|---|-----|
| Diaphragm | Standard Nitrile in #316 stainless steel housing | GNG, GNO, GPG, GPO, GRG, GRO, GSG, GSO | Q1 |
| | Ethylene propylene in #316 stainless steel housing | Not available on GNG, GNO, GRG, GRO1. Available on all other GNG, GNO, GPG, GPO, GRG, GRO, GSG, GSO | Q3 |
| | Viton® fluorocarbon in #316 stainless steel housing | GNG, GNO, GPG, GPO, GRG, GRO, GSG, GSO | Q4 |
| Pressure connection | 1/4"-18 NPT external thread | GNG, GNO, GRG, GRO | Z |
| | 1/2"-14 NPT external thread, 1/4"-18 NPTF internal thread. Standard actuator only. | GNG, GNO, GRG, GRO | Z16 |
| | 7/16"-20 UNF-2B internal thread | GNG, GNO, GPG, GPO, GQG, GQO, GRG, GRO, GSG, GSO, GTG, GTO | Z18 |

9012G and 9016G industrial pressure and vacuum switches

9016G vacuum switches

Control applications



9016GAW2

9016GAW Switches for Sensitive Control Applications

9016GAW vacuum switches have double throw contacts. Normally open and normally closed circuits allow the use of these controls for standard or reverse action applications.

Standard controls can be mounted from the front using the bracket provided. Two mounting screws are required for firm attachment to any smooth, flat surface. Allowance must be made for flange projection.

Controls with the Form F modification include two mounting feet with 9/32" mounting holes on 3-3/4 in. centers. The Range and Differential adjustments are accessed by removing the front cover.

- Maximum allowable positive pressure: 100 psig.
- Diaphragms are oil resisting, nitrile butadiene rubber (Buna-N).
- For electrical ratings and temperature limitations, see table on page 68.
- For dimensions and modifications, see page 80.

9016GAW Vacuum Switch for Control Applications, Diaphragm Actuated

| Range on Decreasing Vacuum (inHg) | Adjustable Differential (inHg) Adds to Range (1) | | Contact Arrangement | Pipe Tap (NPTF) | Class 9016 Type NEMA Enclosure Type 4, 4X & 13 |
|-----------------------------------|--|-------------|---------------------|-----------------|--|
| | @ Minimum Range | @ Mid-Range | | | |
| 0-28.7 | 0.8-9 | 1.3-7.4 | 1 N.O.-1 N.C. | 1/4"-18 | 9016GAW1 |
| 0-25 | 5-20 | 5-20 | 1 N.O.-1 N.C. | 1/4"-18 | 9016GAW2 |
| 0-28.3 | 1-9 | 1.7-7.4 | 2 N.O.-2 N.C. | 1/4"-18 | 9016GAW21 |
| 0-25 | 5-20 | 5-20 | 2 N.O.-2 N.C. | 1/4"-18 | 9016GAW22 |

Specifications

| | | |
|-------------------------------|---|-------------------|
| Fluids Controlled | Air, water, hydraulic oils, gases, steam (depending on the model) | |
| Pressure Connection | NEMA 4, 4X & 13: 1/4"-18 NPTF (standard), G1/4 (BSP) female, or 1/2"-14 NPT. NEMA 7 & 9: 1/4" NPTF | |
| Weight (approximate) | Type 4, 4X, and 13: 3 lb (1.36 kg); Type 7 & 9: 10 lb (4.54 kg) | |
| Voltage Limits | 600 V | |
| Continuous Current | 10 A | |
| Electrical Connections | NEMA 4, 4X & 13: 1/2"-14 NPTF NEMA 7 & 9: 3/4"-14 NPTF | |
| Standards/Ratings | CE, UKCA, IEC 60947.4.1, UL 508, CSA C22-2 n°14 | |
| Temperature Ratings | Minimum | Maximum |
| Ambient | -23 °C (-10 °F) | +85 °C (+185 °F) |
| Diaphragm | -40 °C (-40 °F) | +120 °C (+250 °F) |
| Media | Piston | -26 °C (-15 °F) |
| | All with Form Q4 | -26 °C (-15 °F) |

Operating Curves

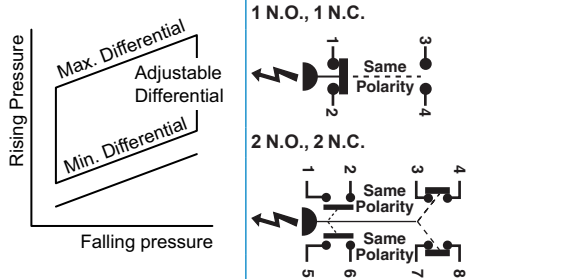

Connection

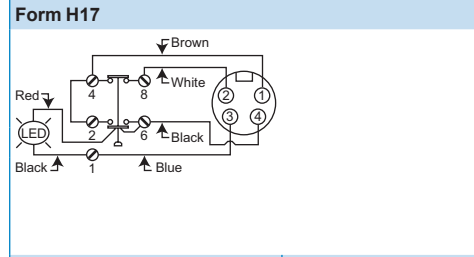

SPDT snap switches contain two double-break contact elements (1 N.O., 1 N.C.) that must be used on circuits of the same polarity.
DPDT snap switches contain two electrically separated sets of contact elements allowing use on circuits of opposite polarity. Each set contains two double-break contact elements (1 N.O., 1 N.C.) that must be used on circuits of the same polarity.

Form H10

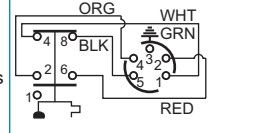

Form H11

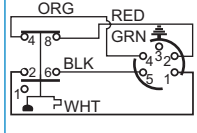

| | | |
|-------------------------------|-----------|---|
| Acceptable Wire Sizes: | 12-22 AWG | Recommended Terminal Clamp Torque: |
|-------------------------------|-----------|---|

(1) Add the Differential to the Range to obtain the operating point on increasing vacuum (within vacuum limitations). The differential increases linearly over the range. The minimum differential doubles with NEMA 7 & 9 enclosures.



9012G and 9016G industrial pressure and vacuum switches

9016G vacuum switches

Power applications



9016GVG1J09E



9016GVG1J10F

9016GVG Power Switches

The 9016GVG1 is designed as a companion to the 9036GG float switches in common use on vacuum heating pumps. Electrical ratings of float and vacuum switch types are equal.

For dimensions and modifications, see page 80.

9016GVG Vacuum Switch for Power Applications NEMA 1 Enclosure Contacts Open on Increasing Vacuum

| Cut-Out Range, inHg | Approximate Adjustable Differential, inHg | Cut-In Range, inHg | Poles | Pressure Connection | Vacuum Setting, inHg | NEMA 1 Enclosure Class 9016 Type (1) |
|---------------------|---|--------------------|-------|---------------------|---|--------------------------------------|
| 5-25 | 5-10 inHg | 0-20 | 2 | 1/4"-18 NPSF | 3-8 | 9016GVG1J09● |
| | | | | | 16.5-25 | 9016GVG1J10● |
| | | | | | 17-22 | 9016GVG1J11● |
| | | | | | 18-23 | 9016GVG1J12● |
| | | | | | 20-25 | 9016GVG1J13● |
| | | | | | Specify other vacuum (minimum order quantity: 4 pieces) | 9016GVG1J99● |

Specifications

| | | |
|---|---|-------------------|
| Fluids Controlled | Air, water, hydraulic oils, gases, steam (depending on the model) | |
| Pressure Connection | 1/4"-18 NPTF (standard), G1/4 (BSP) female, or 1/2"-14 NPT. See Forms table, page 83. | |
| Max. Allowable Positive Pressure | 100 psig | |
| Weight (approximate) | 2 lb (0.91) | |
| Voltage Limits | 600 V | |
| Continuous Current | 10 A | |
| Electrical Connections | 3 knockouts for 1/2" conduit | |
| Standards/Ratings | CE, UKCA, IEC 60947.4.1, UL 508, CSA C22-2 n°14 | |
| Temperature Ratings | Minimum | Maximum |
| Ambient | -23 °C (-10 °F) | +85 °C (+185 °F) |
| Media | Diaphragm -40 °C (-40 °F) | +120 °C (+250 °F) |
| | Piston -26 °C (-15 °F) | |
| | All with Form Q4 -26 °C (-15 °F) | |

Operating Curves

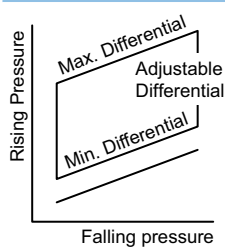

Contact Blocks

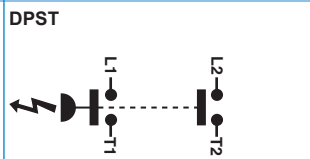

Acceptable Wire Sizes:

8-14 AWG

Recommended Terminal Clamp Torque:

22-27 lb-in

For other ratings and specifications, see page 68.

(1) Available Modifications for 9016GVG Vacuum Switches

| Description | Form |
|--|------|
| 3-way lever plus nameplate with marking: <i>Float only—Vacuum and Float—Continuous</i> (factory modification only) | E |
| Mounting bracket (for retrofit, order 9049A53 bracket kit) | F |
| Reverse action, normally open contacts | R |
| 1/4 in. male pipe connection (1/4"-18 NPT, external thread) (for retrofit, use 1/4" pipe nipple) | Z |



Machine Tool Pressure Switch Dimensions

9012GAW, GDW, GWK 1, 21

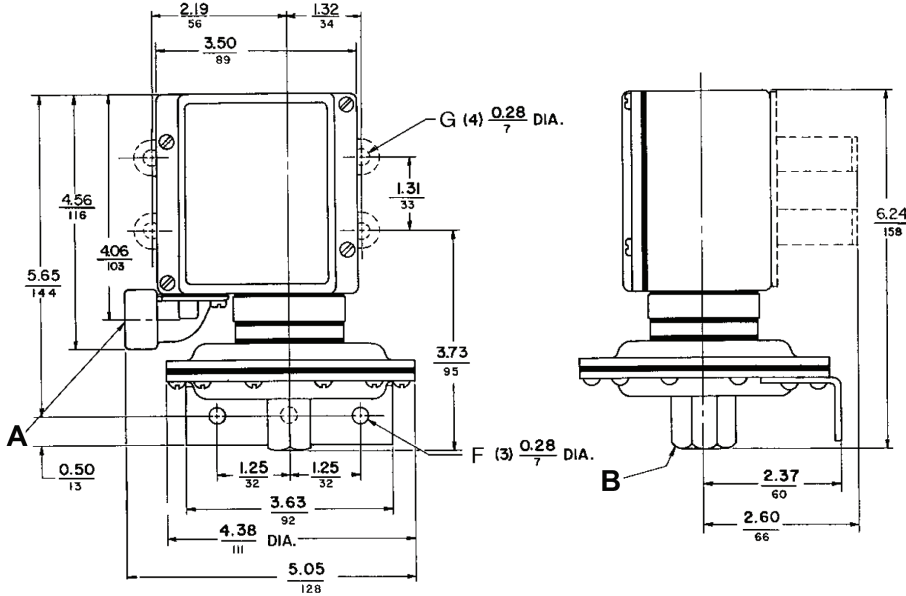

A: Conduit connection: G•W = 1/2-14 NPT; G•WM = 20mm BS4568, Form M12 = Pg13.5; DIN40430.
B: Pressure connection: G•W = 1/4"-18 NPTF; G•WM = 8; Form M14 = G 1/4 BS 2779; RP1/4 ISO 711; R 1/4 DIN 2999; GJ 1/4 UN1339.

9012GAW, GBW, GCW, GDW, GEW, GFW, GWK, GLW, and GMW (except GAW, GDW, GWK 1, 21)

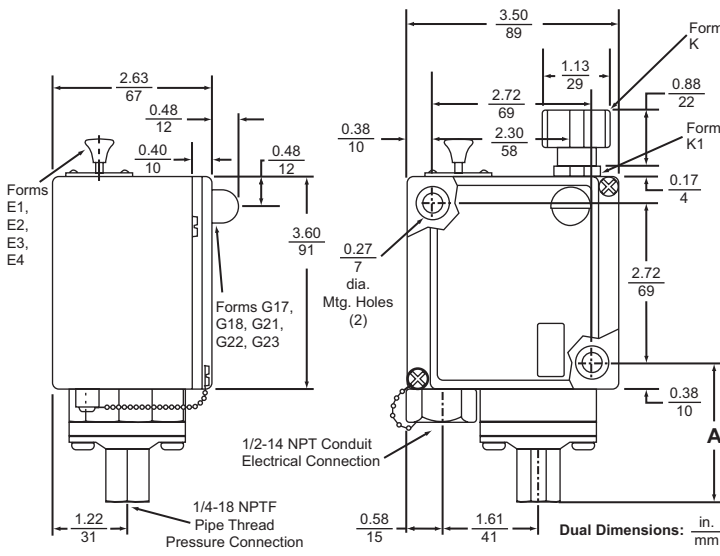

| Type | Dimension A, in. (mm) |
|--|-----------------------|
| GAW, GDW, GWK 2, 4, 5, 6, 22, 24, 25, 26 | 2.33 (59) |
| GBW, GEW, GLW 1, 2, 21 | 2.23 (57) |
| GCW, GFW, GMW 1, 2, 3, 4, 21, 22, 23, 24 | 3.15 (80) |

NOTE: Dimensions change with metric thread.
 For flange and mounting bracket dimensions for low pressure device, see figure on page 83.

9012G and 9016G industrial pressure and vacuum switches

9012G pressure switches

9012GGW, GHW, GJW (Differential-Pressure)

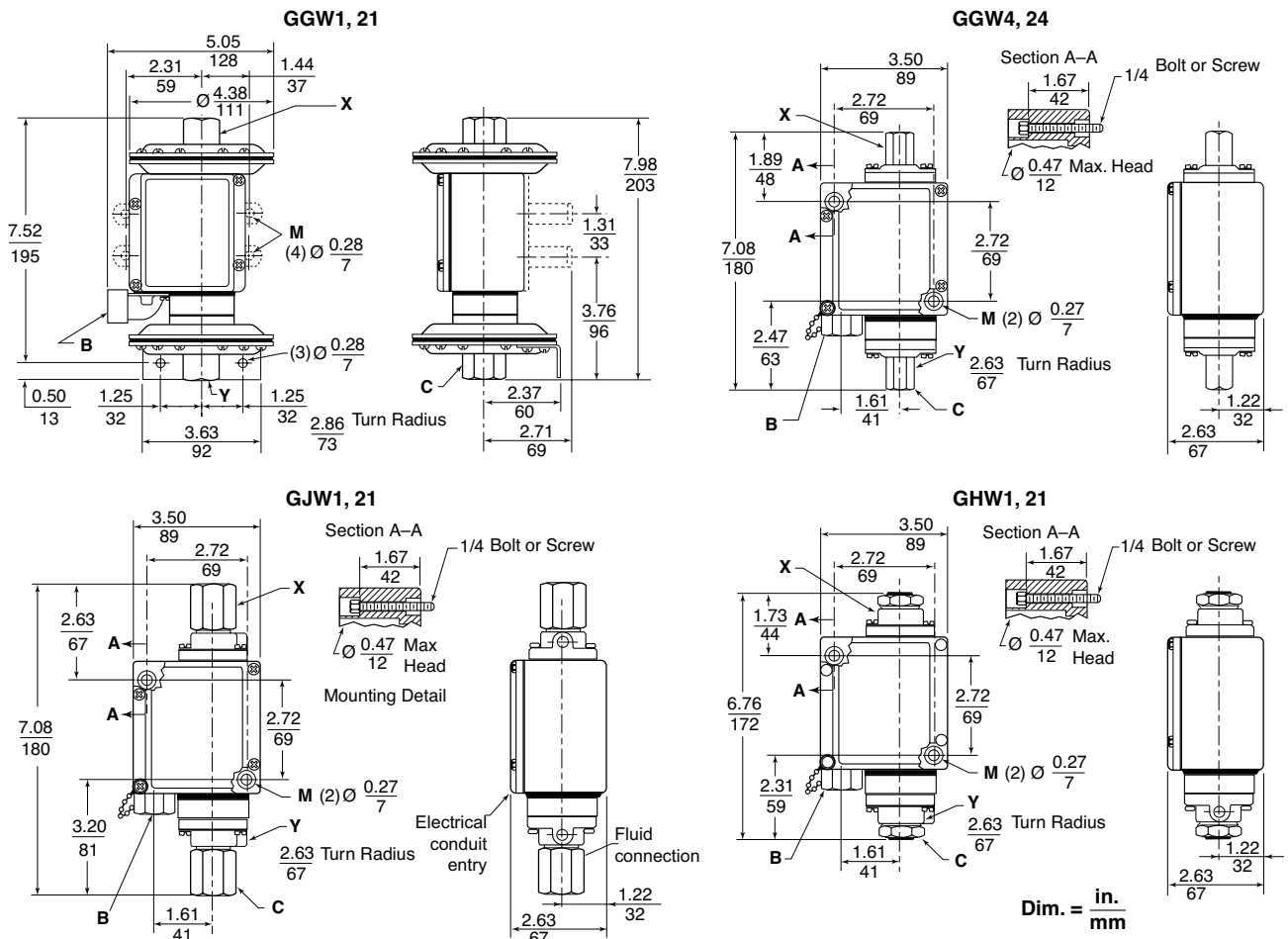

9012GAR, GBR, GCR, GDR, GER, and GFR

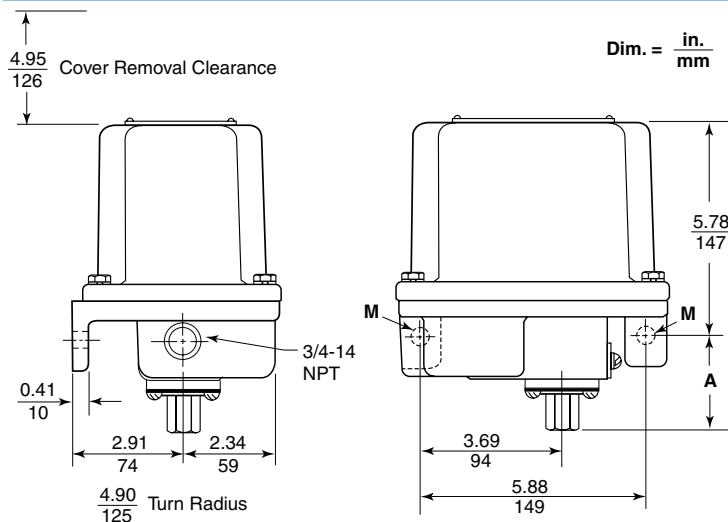

Dimension A for 9016G-R Switches

| Type | Dimension A, in. (mm) |
|---------------------------|-----------------------|
| GAR4, 5, 6, 24, 25, 26 | 1.42 (36) |
| GBR1, 2, 21, 22; GCR1, 21 | 1.32 (34) |
| GCR2, 3, 4, 22, 23, 24 | 2.24 (57) |
| GDR1, 2, 21, 22 | 2.02 (56) |
| GDR4, 5, 6, 24, 25, 26 | 1.42 (36) |
| GER1, 2, 21, 22; GFR1, 21 | 1.32 (34) |
| GFR2, 3, 4, 22, 23, 24 | 2.24 (57) |

9012G and 9016G industrial pressure and vacuum switches

9012G pressure switches

9012GNO1, GRO1

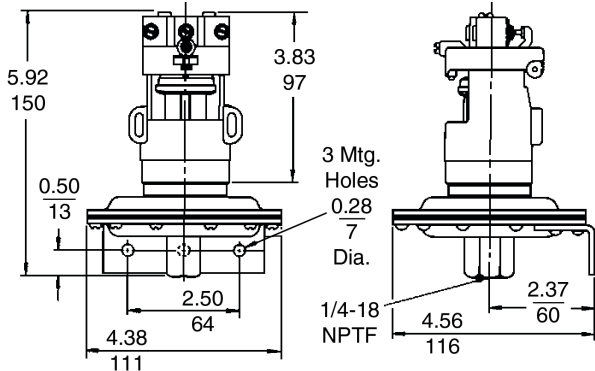

9012GNG1, GRG1

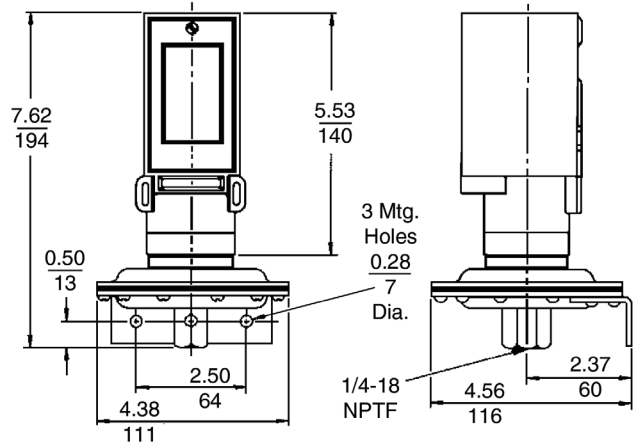

9012GNO, GRO

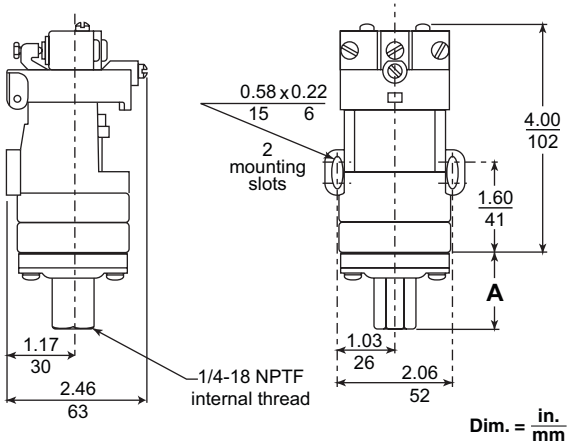

9012GNG, PPG, GQG, GRG, GSG, and GTG

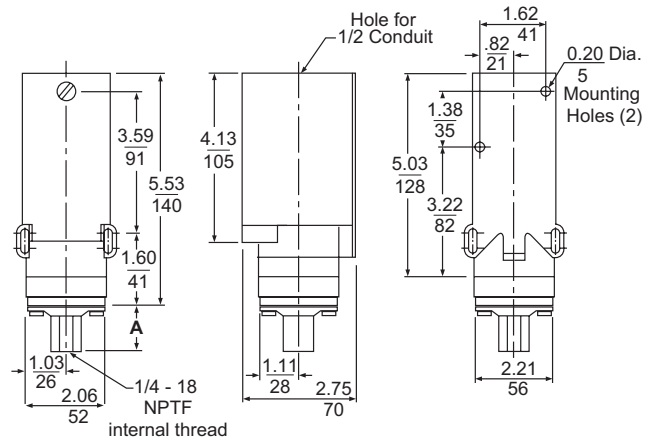

Dimension A for 9012G•O Switches

| 9012 | Dimension A, in. (mm) |
|---------------------|-----------------------|
| GNO, GRO 3, 4, 5, 6 | 1.41 (36) |
| GPO, GSO 1, 2, 3 | 1.31 (33) |
| GQO, GTO 1, 2, 3, 4 | 2.24 (57) |

Dimension A for 9012G•G Switches

| 9012 | Dimension A, in. (mm) |
|---------------------|-----------------------|
| GNG, GRG 3, 4, 5, 6 | 1.41 (36) |
| GPG, GSG 1, 2, 3 | 1.31 (33) |
| GQG, GTG 1, 2, 3, 4 | 2.24 (57) |

Vacuum Switch Dimensions and Modifications

9016GAW Control Vacuum Switches—Dimensions

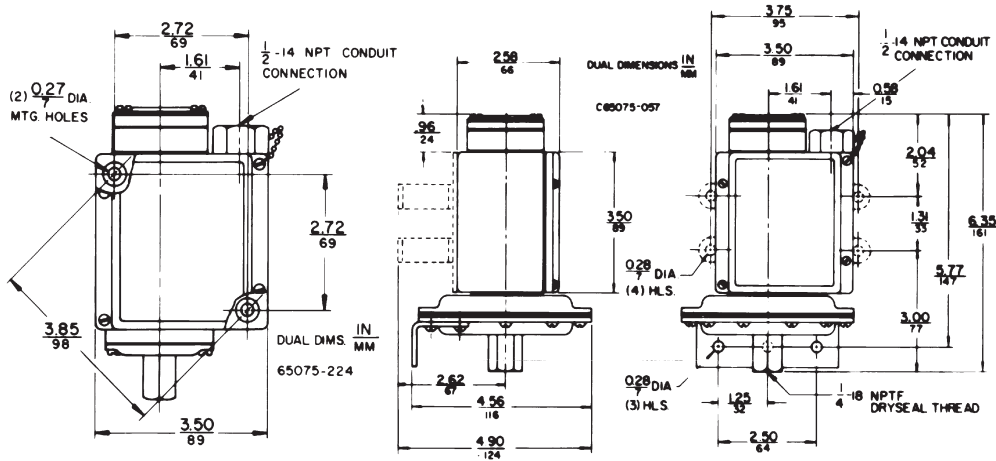

9016GAW Vacuum Switches—Available Modifications

| Description | Form |
|--|------|
| Mounting feet (GAW 1, 21 only) | F |
| Viton® diaphragm with #316 stainless steel flange | Q4 |
| Range scale window (standard with Forms K and K1) | V1 |
| Special setting specified (If indicating only one special setting, specify whether this setting is on increasing or decreasing pressure.) | Y1 |
| 1/4"-18 NPT external thread pressure connection | Z |
| 1/2"-14 NPT external thread, 1/4"-18 NPTF internal thread pressure connection (standard actuator only) | Z16 |

9016GVG Power Vacuum Switches-Dimensions

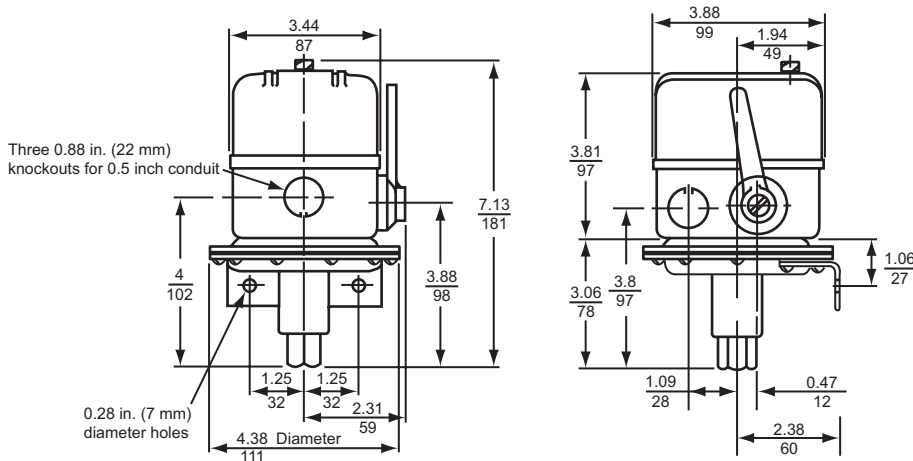

9016GVG Vacuum Switches-Available Modifications

| Description | Form |
|---|------|
| 3-way lever plus nameplate with marking: Float only-Vacuum and Float-Continuous (factory modification only) | E |
| Mounting bracket (for retrofit, order 9049A53 bracket kit) | F |
| Reverse action, normally open contacts | R |
| 1/4 in. male pipe connection (1/4"-18 NPT, external thread) (for retrofit, use 1/4" pipe nipple) | Z |

| | | | | | |
|-----------|----|--------------|----|---------------|----|
| # | | | | | |
| 9012GAR4 | 72 | 9012GCW21 | 71 | XMLA160N2C11 | 47 |
| 9012GAR5 | 72 | 9012GCW22 | 71 | XMLA160N2S11 | 47 |
| 9012GAR6 | 72 | 9012GCW23 | 71 | XMLA300D2C11 | 51 |
| 9012GAW1 | 71 | 9012GCW24 | 71 | XMLA300D2S11 | 51 |
| 9012GAW2 | 71 | 9012GDW22 | 70 | XMLA300D2S12 | 51 |
| 9012GAW4 | 71 | 9012GDW25 | 70 | XMLA300D2S13 | 51 |
| 9012GAW5 | 71 | 9012GFW22 | 70 | XMLA300N2S11 | 51 |
| 9012GAW6 | 71 | 9012GGW21 | 73 | XMLA500D2S13 | 54 |
| 9012GBR1 | 72 | 9012GGW24 | 73 | XMLA500N2C11 | 54 |
| 9012GBW1 | 71 | 9012GHW21 | 73 | XMLAM01V2S11 | 19 |
| 9012GBW2 | 71 | 9016GAW21 | 78 | XMLB001R2S11 | 26 |
| 9012GCR2 | 72 | 9016GAW22 | 78 | XMLB002A2S11 | 28 |
| 9012GCR3 | 72 | 9016GVG1J09● | 79 | XMLB002A2S12 | 28 |
| 9012GCW1 | 71 | 9016GVG1J10● | 79 | XMLB002B2S11 | 28 |
| 9012GCW2 | 71 | 9016GVG1J11● | 79 | XMLB004A2C11 | 31 |
| 9012GCW3 | 71 | 9016GVG1J12● | 79 | XMLB004A2S11 | 31 |
| 9012GDW1 | 70 | 9016GVG1J13● | 79 | XMLB004A2S12 | 31 |
| 9012GDW2 | 70 | 9016GVG1J99● | 79 | XMLB004A2S13 | 31 |
| 9012GDW4 | 70 | | | XMLB004B2S11 | 31 |
| 9012GDW5 | 70 | X | | XMLB010A2C11 | 34 |
| 9012GDW6 | 70 | XMLZL001 | 57 | XMLB010A2S11 | 34 |
| 9012GEW1 | 70 | XMLZL014 | 57 | XMLB010A2S12 | 34 |
| 9012GEW2 | 70 | XMLA001R2S11 | 25 | XMLB010A2S13 | 34 |
| 9012GFW1 | 70 | XMLA001S2S11 | 25 | XMLB010B2S11 | 34 |
| 9012GFW2 | 70 | XMLA002A2C11 | 27 | XMLB010C2C11 | 34 |
| 9012GFW3 | 70 | XMLA002A2S11 | 27 | XMLB010C2S11 | 34 |
| 9012GFW4 | 70 | XMLA002A2S12 | 27 | XMLB020A2S11 | 38 |
| 9012GGW1 | 73 | XMLA002C2S11 | 27 | XMLB020A2S12 | 38 |
| 9012GGW4 | 73 | XMLA004A2C11 | 30 | XMLB020A2S13 | 38 |
| 9012GHW1 | 73 | XMLA004A2S13 | 30 | XMLB020B2S11 | 38 |
| 9012GKW2 | 74 | XMLA004B2S11 | 30 | XMLB020C2S11 | 38 |
| 9012GKW4 | 74 | XMLA010A2C11 | 33 | XMLB020C2S12 | 38 |
| 9012GKW5 | 74 | XMLA010A2S11 | 33 | XMLB035A2C11 | 42 |
| 9012GKW6 | 74 | XMLA010A2S12 | 33 | XMLB035A2S11 | 42 |
| 9012GMW2 | 74 | XMLA010A2S13 | 33 | XMLB035B2S11 | 42 |
| 9012GMW3 | 74 | XMLA010B2S11 | 33 | XMLB070D2S11 | 46 |
| 9012GNG1 | 77 | XMLA010C2S11 | 33 | XMLB070N2S11 | 46 |
| 9012GNG3 | 77 | XMLA020A2C11 | 37 | XMLB160D2C11 | 48 |
| 9012GNG4 | 77 | XMLA020A2S11 | 37 | XMLB160D2S11 | 48 |
| 9012GNG5 | 77 | XMLA020A2S12 | 37 | XMLB160D2S12 | 48 |
| 9012GNG6 | 77 | XMLA020A2S13 | 37 | XMLB160N2S11 | 48 |
| 9012GNO4 | 77 | XMLA020B2C11 | 37 | XMLB300D2C11 | 52 |
| 9012GNO5 | 77 | XMLA020B2S11 | 37 | XMLB300D2S11 | 52 |
| 9012GNO6 | 77 | XMLA020B2S12 | 37 | XMLB300D2S12 | 52 |
| 9012GPG1 | 77 | XMLA020C2S11 | 37 | XMLB300N2S12 | 52 |
| 9012GPG2 | 77 | XMLA035A2C11 | 41 | XMLB500D2C11 | 55 |
| 9012GQG1 | 77 | XMLA035A2S11 | 41 | XMLB500D2S11 | 55 |
| 9012GQG2 | 77 | XMLA035A2S12 | 41 | XMLB500D2S12 | 55 |
| 9012GQG3 | 77 | XMLA035B2C11 | 41 | XMLB500N2C11 | 55 |
| 9012GRG4 | 76 | XMLA035B2S11 | 41 | XMLB500N2S11 | 55 |
| 9012GRG5 | 76 | XMLA035C2C11 | 41 | XMLB500N2S12 | 55 |
| 9012GRO4 | 76 | XMLA070D2C11 | 45 | XMLBL35R2S11 | 23 |
| 9012GTG1 | 76 | XMLA070D2S11 | 45 | XMLBL35R2S13 | 23 |
| 9016GAW1 | 78 | XMLA070D2S12 | 45 | XMLBM02V2C11 | 20 |
| 9016GAW2 | 78 | XMLA070D2S13 | 45 | XMLBM02V2S11 | 20 |
| 9012GAR24 | 72 | XMLA070E2S11 | 45 | XMLBM02V2S12 | 20 |
| 9012GAR25 | 72 | XMLA070E2S13 | 45 | XMLBM05A2S11 | 22 |
| 9012GAW21 | 71 | XMLA070N2S11 | 45 | XMLBS02B2S11 | 28 |
| 9012GAW22 | 71 | XMLA070N2S12 | 45 | XMLBS04B2S11 | 31 |
| 9012GAW24 | 71 | XMLA160D2C11 | 47 | XMLBS04B2S12 | 31 |
| 9012GAW25 | 71 | XMLA160D2S11 | 47 | XMLBS35R2S11 | 23 |
| 9012GAW26 | 71 | XMLA160D2S12 | 47 | XMLBS35R2S12 | 23 |
| 9012GBW21 | 71 | XMLA160D2S13 | 47 | XMLC002B2S11 | 29 |
| 9012GBW22 | 71 | XMLA160E2S11 | 47 | XMLC004B2S11 | 32 |
| | | | | XMLC004B2S12 | 32 |
| | | | | XMLC010B2S11 | 35 |
| | | | | XMLC010C2S11 | 35 |
| | | | | XMLC020B2S11 | 39 |
| | | | | XMLC020B2S12 | 39 |
| | | | | XMLC035B2S12 | 43 |
| | | | | XMLC160D2S11 | 49 |
| | | | | XMLC160D2S12 | 49 |
| | | | | XMLC300D2S11 | 53 |
| | | | | XMLC300D2S12 | 53 |
| | | | | XMLC300D2S13 | 53 |
| | | | | XMLCS02B2S11 | 29 |
| | | | | XMLCS02B2S12 | 29 |
| | | | | XMLCS02B2S13 | 29 |
| | | | | XMLCS04B2S11 | 32 |
| | | | | XMLCS04B2S12 | 32 |
| | | | | XMLCS10A2S11 | 35 |
| | | | | XMLCS35R2S11 | 24 |
| | | | | XMLCS35R2S12 | 24 |
| | | | | XMLCS35R2S13 | 24 |
| | | | | XMLD010B1S11 | 36 |
| | | | | XMLD020C1S12 | 40 |
| | | | | XMLD035B1S11 | 44 |
| | | | | XMLD160D1S13 | 50 |
| | | | | XMLD500D1S11 | 56 |
| | | | | XMLDM02V1S11 | 21 |
| | | | | XZCC43FCP40B | 57 |
| | | | | XZCR1523062K1 | 57 |

