

Commercial Pressure and Float Switches for Power Circuits

Class 9013, 9036, 9037 and 9038

Catalog

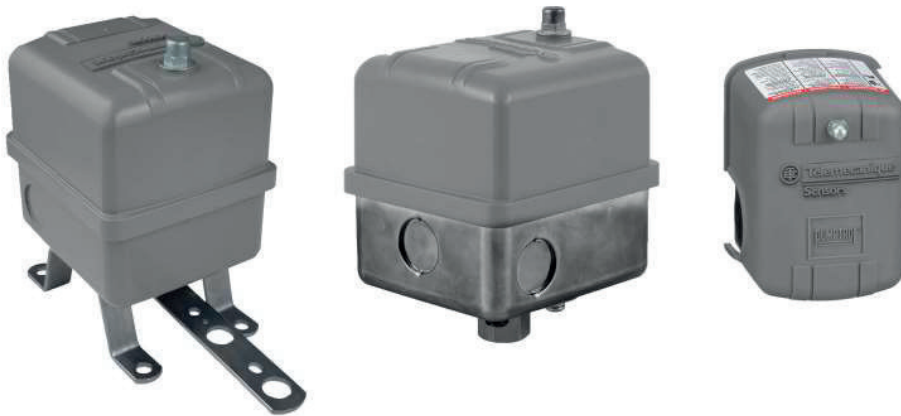

Simply easy!™

PUMPTROL™

 **Telemecanique**
Sensors

Table of contents

Selection Guide — Pumptrol™ Commercial Pressure Switches	4
Class 9013 Electro mechanical, Conforming to UL508 and CSA	4
Selection Guide — Float Switches	6
Class 9036 TypeD — Open Tank, General Purpose	6
Class 9036 Type G — Open Tank, Heavy Duty	7
Class 9049 — Accessories for Class 9036 Type D and G	8
Class 9036 Type FG — Open Tank, Pedestal Style	9
Class 9049 Type UMS1 — Universal Mounting Plate	9
Class 9037 Type E — Closed Tank, Flange Mounted	10
Class 9037 Type H — Closed Tank with Bushing	11
Class 9038 Type A — Mechanical Alternator, Open Tank	12
Class 9038 Type C — Mechanical Alternator, Closed Tank	13
Class 9038 Type D — Mechanical Alternator, Closed Tank	14
Electromechanical Pressure Switches, Class 9013 Types F and G	16
Introduction	16
Settings	17
General Specifications	
Types FSG/FSW, FTG/FTW, and FYG/FYW	18
Types FRG, FHG, and G	19
Interpretation of the Catalog Number	
Class 9013 Type F Water Pump Switches	20
Class 9013 Type F Air Compressor Switches	21
Class 9013 Type G Pressure Switches	22
Selection and Specifications	23
Dimensions	39
Float Switches — Class 9036, 9037, and 9038	40
Introduction	40
Class 9036 Open Tank	40
Class 9037 Closed Tank	41
Class 9038 Mechanical Alternators	41
Selecting a Float Switch	42
Selecting Floats and Rods	42
Temperature Ratings	43
Electrical Ratings	43
Class 9036 Type D and G Open Tank Float Switches	44
Class 9036 Type FG and Class 9049 Accessories	47
Class 9037 Type E Closed Tank Float Switches	48
Class 9037 Type E Flange-Mounted Float Switches	48
Class 9037 Type E Closed Tank Rod Kits	50
Position 2 Operation	51
Position 3 Operation	51
Class 9037 Type H with Screw-in Bushing	52
Class 9038 Type A Mechanical Alternators	54
Class 9038 Type A Open and Sump Tank Mechanical Alternators	54
Class 9038 Type C Mechanical Alternators with Bushing	56
Class 9038 Type D Flange-Mounted Mechanical Alternators	58
Class 9049 Rod Kits for Class 9038 Type D	59
Class 9049 Accessories and Class 9998 Renewal Parts Kits	62



For the complete technical specifications of the products, please refer to our website. For professional use.

Commercial Pressure and Float Switches for Power Circuits



Selection Guide — Pumptrol™ Commercial Pressure Switches

Class 9013 Electro mechanical, Conforming to UL508 and CSA

Pumptrol Family		9013FSG	9013FTG	9013FYG
Applications	Type of Installation	Power circuit	Power circuit	Power circuit
	Controls	Fresh or sea water	Fresh or sea water	Fresh or sea water
	Type of Operation	Regulation between 2 thresholds (adjustable differential). Suitable for all pumps.	Detection of a single threshold (non-adjustable differential)	Regulation between 2 thresholds (adjustable differential). For higher hp and pressure requirements.



Size / Range	psi	20–80	20–65	25–80
	bar	1.38–4.48	1.38–4.48	1.72–5.52
Conforming to Standards		NEMA A600 UL508	UL508	NEMA A600 UL508
Product Certifications		UL, CSA	UL, CSA	UL, CSA
Dimensions (l x h x w) in inches (mm)		3.76 x 2.8x2.78 (95.5 x 71.12x70.6)	3.76 x 2.8x2.78 (95.5 x 71.12x70.6)	3.76 x 2.8x2.78 (95.5 x 71.12x70.6)
Contact Blocks (snap action contacts)		2 N.C.	2 N.C.	2 N.C.
Degree of Protection		NEMA Type 1, NEMA Type 3R, and IP20	NEMA Type 1, NEMA Type 3R, and IP20	NEMA Type 1, NEMA Type 3R, and IP20
Connections	Electrical	Screw terminals	Screw terminals	Screw terminals
	Fluid	Multiple	Multiple	Multiple
Cable Entries		2	2	2
Catalog Numbers		9013FSG***	9013FTG***	9013FYG***
Specifications		Page 16	Page 16	Page 16
Interpretation of Catalog Numbers		Page 18	Page 18	Page 18
Other versions: Form B7, one grommet, CE Form B8, two grommets, CE		— —	— —	— —
NOTE: Inclusion of B7 or B8 grommets will negate UL/CSA approvals for the device, but they may be used for applications which do not require UL/CSA approvals.				



Commercial Pressure and Float Switches for Power Circuits

Selection Guide — Pumptrol™ Commercial Pressure Switches

Pumptrol Family		9013FRG	9013FHG	9013G
Applications	Type of Installation	Power circuit	Power circuit	Power circuit
	Controls	Fresh or sea water	Air only	Water or air
	Type of Operation	Reverse acting, contacts open on falling pressure (adjustable differential)	Control of electrically driven air compressors, contacts open on rising pressure (fixed differential, adjustable cut-out), diaphragm actuated	Light industrial, with higher electrical ratings for direct control of motors in pumps and compressors, contacts open on rising pressure (adjustable differential)



Size / Range	psi	8–150	40–200	10–250
	bar	0.41–10.34	2.76–13.79	0.69–17.24
Conforming to Standards		NEMA A300 UL508	NEMA A600 UL508	NEMA A600 UL508
Product Certifications		UL, CSA	UL, CSA	UL, CSA
Dimensions (l x h x w) in inches (mm)		3.76 x 2.8 x 2.78 (95.5 x 71.12 x 70.6)	3.76 x 2.8 x 2.78 (95.5 x 71.12 x 70.6)	3.68 x 3.85 x 3.44 (93.47 x 97.79 x 87.37)
Contact Blocks (snap action contacts)		2 N.O.	2 N.C.	2 N.C.
Degree of Protection		NEMA Type 1, NEMA Type 3R, and IP20	NEMA Type 1, NEMA Type 3R, and IP20	NEMA Type 1, NEMA Type 3R, NEMA Type 7, NEMA Type 9, and IP20
Connections	Electrical	Screw terminals	Screw terminals	Screw terminals
	Fluid	Multiple	Multiple	Multiple
Cable Entries		2	2	3 knock-outs available
Catalog Numbers		9013FRG***	9013FHG***	9013G***
Specifications		Page 16	Page 16	Page 16
Interpretation of Catalog Numbers		Page 19	Page 19	Page 19
Other versions: Form B7, one grommet, CE Form B8, two grommets, CE		— —	— —	— —
NOTE: Inclusion of B7 or B8 grommets will negate UL/CSA approvals for the device, but they may be used for applications which do not require UL/CSA approvals.				

Commercial Pressure and Float Switches for Power Circuits



Selection Guide — Float Switches

Class 9036 TypeD — Open Tank, General Purpose

Type of Installation	Horsepower rated
Product Features	2-poles witch, lever operated Standard action — contacts close on liquid rise Reverse action — contacts open on liquid rise

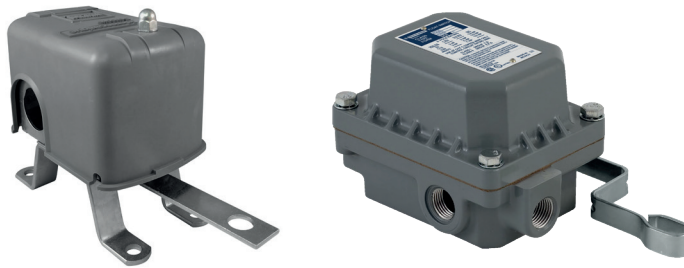

Fluids Controlled	Water, hydraulic oils, corrosive fluids		
Fluid Characteristics	Fresh water, sea water, hydraulic oils, and corrosive fluids with a density ≥ 0.8		
Contact Arrangement	Standard: 2 N.O. (DPST), Form R: 2 N.C. (DPST), Form H: 1 N.O. and 1 N.C. (SPDT)		
Degree of Protection	NEMA Type1	NEMA Type 4	NEMA Type 7,9
Electrical Connection	4 screw terminals, 3 knockouts for 1/2 in. conduit entry	4 screw terminals, 2 cable entries, 3/4-14 conduit entry	
Ambient Temperature	-22 to + 200 °F (-30 to+93°C)		
Catalog Numbers	9036DG...	9036DW...	9036DR...
Page	44		

Commercial Pressure and Float Switches for Power Circuits

Selection Guide — Float Switches

Class 9036 Type G — Open Tank, Heavy Duty

Type of Installation	Horsepower rated
Product Features	2-pole switch Standard action — contacts close on liquid rise Reverse action — contacts open on liquid rise

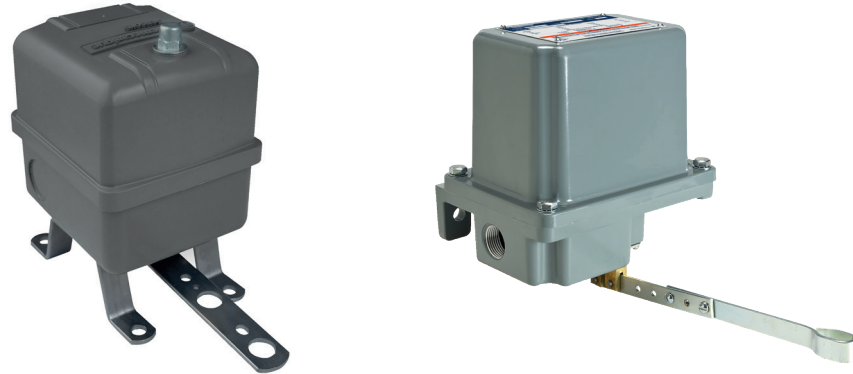







Fluids Controlled	Water, hydraulic oils, corrosive fluids		
Fluid Characteristics	Fresh water, sea water, hydraulic oils, and corrosive fluids with a density ≥ 0.8		
Contact Arrangement	Standard: 2 N.O. (DPST), Form R: 2 N.C. (DPST), Form H: 1 N.O. and 1 N.C. (SPDT)		
Degree of Protection	NEMA Type 1	NEMA Type 4	NEMA Type 7, 9
Electrical Connection	4 screw terminals, 3 knockouts for 1/2 in. conduit entry	4 screw terminals, 2 cable entries, 3/4-14 conduit entry	
Ambient Temperature	-22 to +200 °F (-30 to +93 °C)		
Catalog Numbers	9036GG...	9036GW...	9036GR...
Page	44		

Commercial Pressure and Float Switches for Power Circuits

Selection Guide — Float Switches

Class 9049 — Accessories for Class 9036 Type D and G

Accessory Kits	Tapped-at-Top Floats (#304 SS) ^[1]		Center-Hole Floats (#304 SS) ^[2]		Additional Tubing ^[3]	
						
Tubing (rods)	5 ft brass	5 ft SS	5 ft brass	5 ft SS	2.5 ft brass	2.5 ft SS
Net buoyancy in water 7 in. float^[4]	60	60	70	70	—	—
Total weight of stops oz (g)	3 (85)	3 (85)	6 (170)	6 (170)	—	—
Number of stops	2	2	4	4	—	—
Weight of the included 5 ft rod oz (g)	18.5 (524)	16.9 (479)	18.5 (524)	16.9 (479)	—	—
Weight per ft of extra rod oz (g)	3.7 (105)	3.4 (96)	3.7 (105)	3.4 (96)	3.7 (105)	3.4 (96)
Catalog Numbers	9049A6	9049A6S	9049A6C	9049A6CS	9049T1	9049T1S

^[1] Maximum recommended tubing length for tapped-at-top float: 12.5 ft (3810 mm).

^[2] Maximum recommended tubing length for center-hole float: 30 ft (9144 mm).

^[3] Additional tubing kits add on to float accessory kits and include a connector.

^[4] Net buoyancy calculated with the float 80% submerged, allowing for a 20% operating margin. Buoyancy data calculated for use in water. Contact the Sensor

Competency Center for buoyancy data in media having a specific gravity different than water (1.0).

NOTE: When ordering float accessories, first specify the desired accessory kit, then as a second item, give the catalog number and the quantity of the additional tubing kits required. For example, for a 9049A6C kit with 15 ft of tubing, specify:

- 9049A6C, quantity = 1 (float with 5 ft of tubing)
- 9049T1, quantity = 4 (2.5 ft of tubing each, for a total of 10 additional ft)

Compensating Spring

Compensating springs support the weight of long rods that cannot be supported by center-hole floats.



Example

Calculation example Measuring 15 ft of tank depth <i>System has 15 ft of brass rod, 4 stops, and a center hole float.</i> Buoyancy is positive, so no compensating spring is required	Float buoyancy	70.0 oz
	Total weight	(61.5 oz)
	Weight of stops:	(6.0 oz)
	Weight of 5 ft of brass rod (included):	(18.5 oz)
	Weight of 10 ft of brass rod (separate):	(37.0 oz)
	Buoyancy	8.5 oz

Commercial Pressure and Float Switches for Power Circuits

Selection Guide — Float Switches

Class 9036 Type FG — Open Tank, Pedestal Style

Type of Installation	Horsepower rated		
Product Features	2-pole switch, forward or reversing Contacts open or close on liquid rise (field convertible)		
			
Fluids Controlled	Water, hydraulic oils, corrosive fluids		
Fluid Characteristics	Fresh water, sea water, hydraulic oils, and corrosive fluids with a density ≥ 0.8		
Contact Arrangement	2 N.O. or 2 N.C. (DPST), depending on rod connection		
Degree of Protection	NEMA Type 1		
Electrical Connection	4 screw terminals, 2 cable entries 0.88 in. (22.4 mm) with 0.84 in. (21.3 mm) across flat		
Ambient Temperature	-22 to +200 °F (-30 to +93 °C)		
Catalog Numbers	9036FG	9049A60	9049A61
Description	2-pole, pedestal-style sump pump switch	Plastic, center-hole float	33.75 in. aluminum rod, 2 float stop assemblies, and attaching hardware
Page	46		

NOTE : Also available in batch of 250 pcs : "Add C250" at the end of your reference

Class 9049 Type UMS1 — Universal Mounting Plate

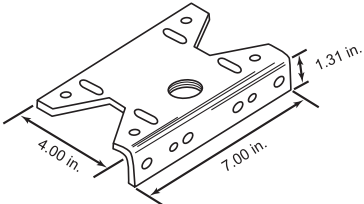
Description	Mounting plate	Figure 1: 9049UMS1 Dimensions
Product Features	Pedestal mount	
		
Material	Cold rolled steel	
Finish	Painted, powder coated	
Mounting Connection	Threaded to accept 1 in. diameter iron pipe	
Catalog Numbers	9049UMS1	

Commercial Pressure and Float Switches for Power Circuits

Selection Guide — Float Switches

Class 9037 Type E — Closed Tank, Flange Mounted

Type of Installation	Horsepower rated
Product Features	2-pole switch Standard action — contacts close on liquid rise Reverse action — contacts open on liquid rise



Fluids Controlled	Water, hydraulic oils, corrosive fluids		
Fluid Characteristics	Fresh water, sea water, hydraulic oils, and corrosive fluids with a density ≥ 0.8		
Contact Arrangement	Standard: 2 N.O. (DPST), Form R: 2 N.C. (DPST)		
Degree of Protection	NEMA Type 1	NEMA Type 4	NEMA Type 7, 9
Electrical Connection	4 screw terminals, 3 knockouts for 1/2 in. conduit entry	4 screw terminals, 2 cable entries, 3/4-14 conduit entry	
Ambient Temperature	-22 to +200 °F (-30 to +93 °C)		
Catalog Numbers	9037EG...	9037EW...	9037ER...
Page	48		

NOTE: For float and rod kits, refer to page 50.

Commercial Pressure and Float Switches for Power Circuits

Selection Guide — Float Switches

Class 9037 Type H — Closed Tank with Bushing

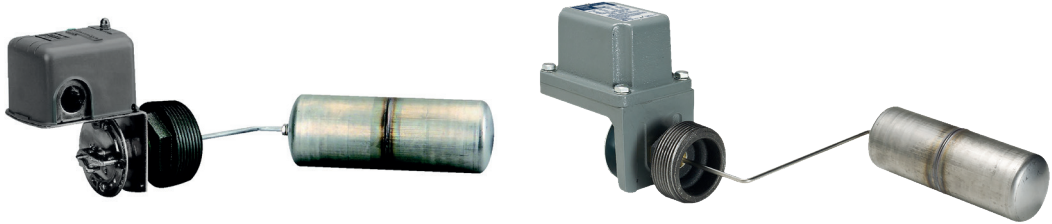
Type of Installation	Horsepower rated		
Product Features	2-pole switch Standard action — contacts close on liquid rise Reverse action — contacts open on liquid rise		
			
Fluids Controlled	Water, hydraulic oils, corrosive fluids		
Fluid Characteristics	Fresh water, sea water, hydraulic oils, and corrosive fluids with a density ≥ 0.8		
Contact Arrangement	Standard: 2 N.O. (DPST). Form R: 2 N.C. (DPST). ⁽¹⁾		
Degree of Protection	NEMA Type 1	NEMA Type 4	NEMA Type 7, 9
Electrical Connection	4 screw terminals, 3 knockouts for 1/2 in. conduit entry	4 screw terminals, 2 cable entries, 3/4-14 conduit entry	
Ambient Temperature	-22 to +200 °F (-30 to +93 °C)		
Catalog Numbers	9037HG...	9037HW...	9037HR...
Page	52		

⁽¹⁾ NEMA Type 1 devices can be field modified for reverse action. NEMA Type 4, 7, and 9 devices cannot be field modified for reverse action.

Commercial Pressure and Float Switches for Power Circuits

Selection Guide — Float Switches

Class 9038 Type A — Mechanical Alternator, Open Tank

Type of Installation	Horsepower rated
Product Features	4-pole switch Standard action — contacts close on liquid rise Reverse action — contacts open on liquid rise



Fluids Controlled	Water, hydraulic oils, corrosive fluids		
Fluid Characteristics	Fresh water, sea water, hydraulic oils, and corrosive fluids with a density ≥ 0.8		
Contact Arrangement	4 N.O. (2 DPST)		
Degree of Protection	NEMA Type 1	NEMA Type 4	NEMA Type 7, 9
Electrical Connection	8 screw terminals, 4 knockouts for 1/2 in. or 3/4 in. conduit entry	8 screw terminals, 2 cable entries, 3/4-14 conduit entry	
Ambient Temperature	-22 to +200 °F (-30 to +93 °C)		
Catalog Numbers	9038AG...	9038AW...	9038AR...
Page	54		

Commercial Pressure and Float Switches for Power Circuits

Selection Guide — Float Switches

Class 9038 Type C — Mechanical Alternator, Closed Tank

Type of Installation	Horsepower rated
Product Features	4-pole switch Standard action — contacts close on liquid rise Reverse action — contacts open on liquid rise

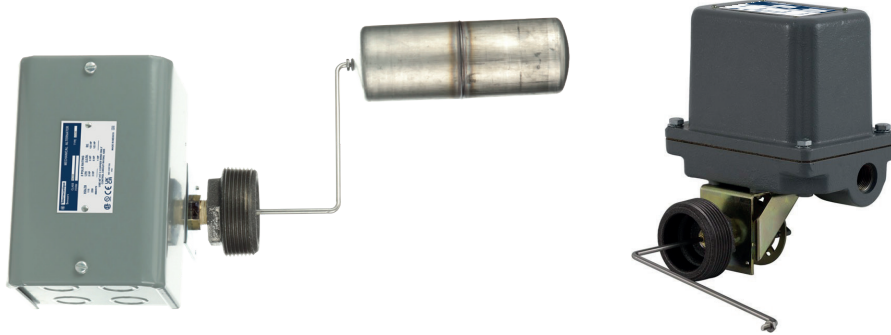

Fluids Controlled	Water, hydraulic oils, corrosive fluids		
Fluid Characteristics	Fresh water, sea water, hydraulic oils, and corrosive fluids with a density ≥ 0.8		
Contact Arrangement	4 N.O. (2 DPST), alternating contacts		
Degree of Protection	NEMA Type 1	NEMA Type 4	NEMA Type 7, 9
Electrical Connection	8 screw terminals, 8 knockouts for 1/2 in. or 3/4 in. conduit entry	8 screw terminals, 2 cable entries, 3/4-14 conduit entry	
Ambient Temperature	-22 to +200 °F (-30 to +93 °C)		
Catalog Numbers	9038CG...	9038CW...	9038CR...
Page	56		

Commercial Pressure and Float Switches for Power Circuits

Selection Guide — Float Switches

Class 9038 Type D — Mechanical Alternator, Closed Tank

Type of Installation	Horsepower rated
Product Features	4-pole switch Standard action — contacts close on liquid rise Reverse action — contacts open on liquid rise

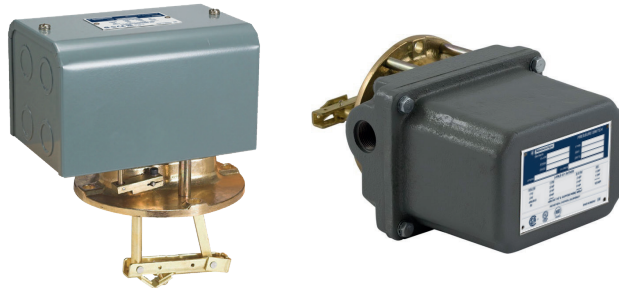

Fluids Controlled	Water, hydraulic oils, corrosive fluids		
Fluid Characteristics	Fresh water, sea water, hydraulic oils, and corrosive fluids with a density ≥ 0.8		
Contact Arrangement	4 N.O. (2 DPST)		
Degree of Protection	NEMA Type 1	NEMA Type 4	NEMA Type 7, 9
Electrical Connection	8 screw terminals, 8 knockouts for 1/2 in. or 3/4 in. conduit entry	8 screw terminals, 2 cable entries, 3/4-14 conduit entry	
Ambient Temperature	-22 to +200 °F (-30 to +93 °C)		
Catalog Numbers	9038DG...	9038DW...	9038DR...
Page	58		

Commercial Pressure and Float Switches for Power Circuits

Selection Guide — Float Switches

Type of Installation	Float Kits	Float Rod Kits
-----------------------------	-------------------	-----------------------



Material	#304 SS	#316 SS	#304 SS	#316 SS	—	—	—	—	—	—
Dimensions, in. (mm) Diameter x Length	3.625 x 4.5 (92 x 114)	3.625 x 4.5 (92 x 114)	2.5 x 7 (64 x 178)	2.5 x 7 (64 x 178)	—	—	—	—	—	—
R Dimension, in. (mm)	—	—	—	—	1.75 (44)	2.50 (64)	3.25 (83)	5.25 (133)	7.25 (184)	12.25 (311)
H Dimension, in. (mm)	—	—	—	—	8.25 (210)	9.00 (229)	9.50 (241)	11.75 (298)	13.75 (349)	18.75 (476)
Catalog Numbers	9049EF1	9049EF2	9049HF3	9049HF4	9049ER1	9049ER2	9049ER3	9049ER5	9049ER7	9049ER12
Pages	48-58-62				48-50-51-59-60-61-62					

Figure 2: Float and Rod Kits



9038DG shown with rod kit 9049ER5 and float kit 9049EF1 installed

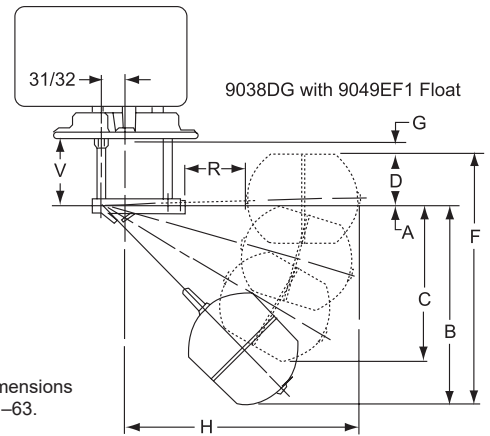

For additional dimensions refer to pages 61–63.

Commercial Pressure and Float Switches for Power Circuits



Electromechanical Pressure Switches, Class 9013 Types F and G

Introduction

The Pumptrol Class 9013 Type F commercial pressure switches are UL Listed and CSA certified as commercial control equipment. Type G pressure switches are UL Listed and CSA certified as commercial / light industrial control equipment.

The Type FHG compressor pressure switch is used to control electrically driven air compressors. It is diaphragm actuated, and its contacts open on rising pressure.

The Type FSG, FTG, FYG, and FRG water pump pressure switches are used to control electrically driven water pumps. They are diaphragm actuated.

- The Type FSG standard water pump switch is suitable for all types of pumps, including jets, submersible, and reciprocating.
- The Type FTG fixed differential water pump switch is suitable for all types of pumps, including jets, submersible, and reciprocating. It is an ideal choice for OEM markets. Minimum quantity restrictions apply.
- The Type FYG is designed to meet higher horsepower and pressure requirements.
- The Type FRG is reverse acting: the contacts open on falling pressure.

The Type G commercial / light industrial pressure switch is used to control electrically driven water pumps and air compressors. It has higher electrical ratings for direct control of motors in pump and compressor applications. The Type G switch is diaphragm actuated, and its contacts open on rising pressure.

Setting Points

Every pressure switch has two setting points: one on rising pressure and one of falling pressure. For pumps and compressors, the setting point on rising pressure is called the trip point or cut-out; the setting point on falling pressure is called the reset point or cut-in.

Differential

The differential is the difference in pressure between the trip point (cut-out) and the reset point (cut-in). It can be adjustable or fixed. **Example** — Cut-in (30 psi) / Cut-out (50 psi): Differential = 20 psi

Range

The range indicates the pressure limits within which the settings can be adjusted. The range is referenced to the setting point on rising pressure (trip point). The differential subtracts from the trip point setting. When using a diaphragm-actuated switch, system pressure during the normal operating cycle should never exceed the upper limit of the range. Excessive pressure will greatly reduce the life of the diaphragm.

Maximum Allowable Pressure

Maximum allowable pressure is the pressure to which a switch can be subjected without causing a change in operating characteristics, shift in settings, or damage to the device. Pressure surges may occur in a system during the start up of a machine or from valve operation. Surges are not normally detrimental to the life of a switch if the surge is within the maximum allowable pressure rating of the switch. Diaphragm-actuated switches should not be subjected to more than 10 surges per day. More frequent surges will greatly reduce the life of the diaphragm.



Commercial Pressure and Float Switches for Power Circuits

Electromechanical Pressure Switches, Class 9013 Types F and G

Settings

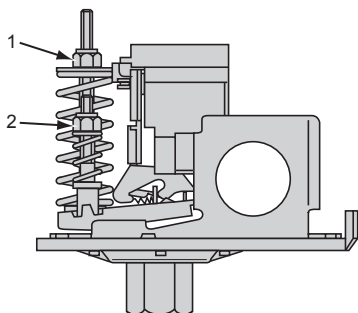

Pressure switches with adjustable differential (Types FSG, FYG, and FRG)

When setting the pressure switch, adjust the setting point on falling pressure first, then the setting point on rising pressure (PB).

- **Setting point on falling pressure**
The setting point on falling pressure is set by adjusting range-nut 1.
- **Setting point on rising pressure**
The setting point on rising pressure is set by adjusting range-nut 2.

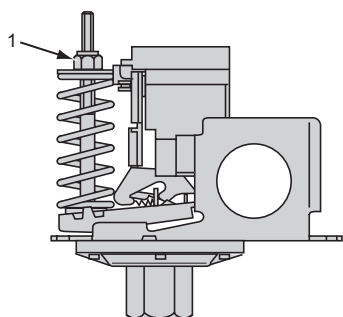

Pressure switches with fixed differential (Types FTG and FHG)

Only the setting point on rising pressure is adjustable.

- **Setting point on rising pressure**
The setting point on rising pressure is set by adjusting range-nut 1.
- **Setting point on falling pressure**
The setting point on falling pressure is not adjustable.

The difference between the tripping and resetting points of the contact is the inherent differential of the switch (due to factors such as contact differential and friction).

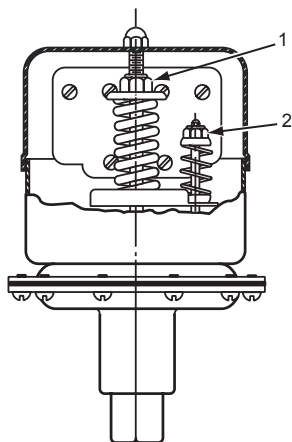

Pressure switches with adjustable differential (Type G)

When setting the pressure switch, adjust the setting point on falling pressure first, then the setting point on rising pressure.

- **Setting point on falling pressure**
The setting point on falling pressure is set by adjusting range-nut 1.
- **Setting point on rising pressure**
The setting point on rising pressure is set by adjusting range-nut 2.

Commercial Pressure and Float Switches for Power Circuits

Electromechanical Pressure Switches, Class 9013 Types F and G

General Specifications

Types FSG/FSW, FTG/FTW, and FYG/FYW

Table 1: Environment

Type	FSG/FSW	FTG/FTW	FYG/FYW
Conforming to standards	UL 508, NEC Article 430-84, ANSI/NSF Standard 61, FDA 21CFR.2600		
Product approvals	UL, CSA		
Degree of protection	IP20, NEMA Type 1 (Types F•G). NEMA Type 3R (Types F•W) must be mounted in vertical position to maintain enclosure rating.		
Operating position	IP20 and NEMA Type 1 in any position, NEMA Type 3R in the vertical position only.		
Operating rate	10 cycles/m		
Repeat accuracy	±3% of the range		
Ambient air temperature			
Storage	-22 to 158 °F (-30 to 70 °C)		
Operation	-22 to 158 °F (-30 to 70 °C)		
Fluids Controlled	Fresh water (or sea water with Form Q)		
Materials	Cover: polypropylene, Noryl® thermoplastic resin or equivalent for Type 3R. Component material in contact with fluid: flange, zinc plated or equivalent (fluid entry), nitrile or equivalent rubber (diaphragm)		
Fluid connection	1/8" NPSF internal, 1/4" NPSF internal, 1/2" NPT external, 1/4" bayonet (barbed), 90° elbow 1/4" bayonet, four-way flange, 3/8" NPSF internal, 1/4" flare and other specials		
Electrical connection	2 open side entries, 0.88 in. diameter, with two flats		

Table 2: Contact Block Characteristics

Type of contacts	One 2 pole, 2 N.C. (4 terminal) contacts, snap action
Resistance across terminals	< 25 mΩ
Short-circuit protection	5,000 A
Connection	Screw clamp terminals. Clamping capacity up to 10 AWG (5.261 mm ²)
Electrical durability	100,000 cycles

Table 3: Electrical Ratings

Type (2 pole)	Voltage	FSG/FSW			FTG/FTW			FYG/FYW		
		~ 1Ø Vac	~ 3Ø Vac	Vdc	~ 1Ø Vac	~ 3Ø Vac	Vdc	~ 1Ø Vac	~ 3Ø Vac	Vdc
Power ratings of controlled motors	115 V	1.1 kW (1.5 hp)	1.5 kW (2 hphp)	0.18 kW (.25 hp)	0.75 kW (1 hp)	—	—	1.5 kW (2 hp)	2.2 kW (3 hp)	0.37 kW (.50 hp)
	230 V	1.5 kW (2 hp)	2.2 kW (3 hp)	0.18 kW (.25 hp)	0.75 kW (1 hp)	—	—	2.2 kW (3 hp)	3.7 kW (5 hp)	0.37 kW (.50 hp)
	460 / 575 V	—	0.75 kW (1 hp)	—	—	—	—	—	0.75 kW (1 hp)	—

Commercial Pressure and Float Switches for Power Circuits

Electromechanical Pressure Switches, Class 9013 Types F and G

Types FRG, FHG, and G

Table 4: Environment

Type	FRG	FHG	G
Conforming to Standards	UL 508, NEC Article 430-84, ANSI/NSF Standard 61, FDA 21CFR.2600		
Product approvals	UL, CSA		
Degree of protection	IP20, NEMA Type 1. NEMA Type 3R (only Types G•B) must be mounted in vertical position to maintain enclosure rating		
Operating position	IP20 and NEMA Type 1 in any position, NEMA Type 3R in the vertical position only		
Operating rate	10 cycles/m		
Repeat accuracy	±3% of the range		
Ambient air temperature			
Storage	-22 to 158 °F (-30 to 70 °C)		
Operation	-22 to 158 °F (-30 to 70 °C)		
Fluids Controlled	Fresh water (or sea water with Form Q)		
Materials	Cover: polypropylene, Noryl thermoplastic resin or equivalent for Type 3R, Component material in contact with fluid: flange, zinc plated or equivalent (fluid entry), nitrile or equivalent rubber (diaphragm)		
Fluid connection	1/8" NPSF internal, 1/4" NPSF internal, 1/2" NPT external, 1/4" bayonet (barbed), 90° elbow 1/4" bayonet, four-way flange, 3/8" NPSF internal, 1/4" flare and other specials		
Electrical connection	2 open side entries, 0.88 in. diameter, with two flats		3 knockouts for 1/2" conduit

Table 5: Contact Block Characteristics

Type of contacts	One 2 pole, 2 N.C. (4 terminal) contacts, snap action Type FRG: 1 or 2 pole, 2 N.O. (2 or 4 terminal) contacts, snap action
Resistance across terminals	< 25 mΩ
Short-circuit protection	5,000 A
Connection	Screw clamp terminals. Clamping capacity up to 10 AWG (5.261 mm ²)
Electrical durability	100,000 cycles

Table 6: Electrical Ratings

Type (1 pole) ^[1]	Voltage	FRG			FHG			G		
		~ 1Ø Vac	~ 3Ø Vac	Vdc	~ 1Ø Vac	~ 3Ø Vac	Vdc	~ 1Ø Vac	~ 3Ø Vac	Vdc
Power ratings of controlled motors ^[2]	32 V	—	—	—	—	—	—	—	—	—
	115 V	0.75 kW (1 hp)	—	0.18 kW (.25 hp)	1.1 kW (1.5 hp)	1.5 kW (2 hp)	0.18 kW (.25 hp)	0.75 kW (1 hp)	—	0.37 kW (.50 hp)
	230 V	0.75 kW (1 hp)	—	0.18 kW (.25 hp)	1.5 kW (2 hp)	2.2 kW (3 hp)	0.18 kW (.25 hp)	1.5 kW (2 hp)	—	0.37 kW (.50 hp)
	460 / 575 V	—	—	—	—	0.75 kW (1 hp)	—	1.5 kW (2 hp)	—	—
Type (2 pole) ^[3]										
Power ratings of controlled motors	Voltage	~ 1Ø Vac	~ 3Ø Vac	Vdc	~ 1Ø Vac	~ 3Ø Vac	Vdc	~ 1Ø Vac	~ 3Ø Vac	Vdc
		~ 1Ø Vac	~ 3Ø Vac	Vdc	~ 1Ø Vac	~ 3Ø Vac	Vdc	~ 1Ø Vac	~ 3Ø Vac	Vdc
Power ratings of controlled motors	32 V	—	—	0.18 kW (.25 hp)	—	—	—	—	—	—
	115 V	0.75 kW (1 hp)	0.75 kW (1 hp)	0.18 kW (.25 hp)	1.5 kW (2 hp)	2.2 kW (3 hp)	0.37 kW (.50 hp)	1.5 kW (2 hp)	2.2 kW (3 hp)	0.75 kW (1 hp)
	230 V	0.75 kW (1 hp)	0.75 kW (1 hp)	0.18 kW (.25 hp)	2.2 kW (3 hp)	3.7 kW (5 hp)	0.37 kW (.50 hp)	2.2 kW (3 hp)	3.7 kW (5 hp)	0.75 kW (1 hp)
	460 / 575 V	—	—	—	—	0.75 kW (1 hp)	—	3.7 kW (5 hp)	3.7 kW (5 hp)	—

^[1] Includes: FHG 2, 3, 4, 9, 12, 13, 14, 19, 42, 44, 49

^[2] Type FRG and G devices include 1 N.O. and 1 N.C. contact (Form H).

^[3] Includes: FHG 22, 24, 29, 32, 33, 34, 39, 52, 54, 59

Commercial Pressure and Float Switches for Power Circuits

Electromechanical Pressure Switches, Class 9013 Types F and G

Interpretation of the Catalog Number Class 9013 Type F Water Pump Switches

Example: 9013FSG2J24C20

FS	G	2	J24			C20
Type	Enclosure	Fluid Connection	Differential psi	Range psi	Code psi	Form Modification
FS: Standard Adj Diff ≤ 1.5 hp FT: Fixed Diff ≤ 1 hp FY: Adj Diff ≤ 2 hp FR: Reverse Acting, Adj Diff ≤ 1 hp	G: NEMA 1 W: NEMA 3R	1: 1/8" NPSF Internal	15–30	20–65	Standard Action	C20: Standard pack of 20 devices per box ^[1]
		2: 1/4" NPSF internal	15–30	20–65	J15: 5–21	H 1 N.O. / 1 N.C. contact FRG 2-pole only
		9: 1/4" NPT external	15–30	20–65	J16: 8–20	M1 Maintained manual cut-out lever (Auto-Off) FSG, FYG
		10: 1/4" Bayonet (barbed)	15–30	20–65	J20: 20–40	M3 Momentary manual cut-in lever (Auto-Start) (FRG2–59)
		20: 90° Elbow 1/4" Bayonet	15–30 10–30	20–65 20–50	J18: 20–50	M4 Low pressure cut-off (Auto-Start-Off) FSG, FYG
		22: 1/4" NPSF internal	10–30	20–60	J21: 30–50	M5 Maintained manual cut-in lever (Auto-On) FRG2–59
		29: 1/4" NPT external	6–20	9–30	J24: 40–60	P: Pulsation plug (Type 2 and 9)
		42: 1/4" NPSF internal	6–20	9–30	J33: 50–70	T: 1/2" conduit bushing— 1/2" long thread—on left
		49: 1/4" NPT external	20–30	25–80	J34: 55–85	U: Slip-on connections (load side terminals only) FSG, FYG
		52: 1/4" NPT external	20–30	25–80	J25: 60–80	U2: Slip-on connections (line and load side terminals) FSG, FYG
		59: 1/4" NPT external	20–30	25–80	Reverse Action	Z22: Black cover FSG, FYG
					J17: 8.5–5.5	B7: One grommet, CE mark ^[2]
					J36: 10–5	B8: Two grommets, CE mark ^[2]
			J22: 22–12	Q8: Salt water plastic flange ^[3]		
			J19: 22–16			
			J70: 35–20			
			J23: 40–20			
			J35: 50–30			
			J32: 80–60			
			J51: 100–80			
			J64: 150–120			
			J99: Specify pressure setting			

^[1] Additional bulk packages are available. See Table 7 on page 37

^[2] Inclusion of B7 or B8 grommets will negate UL/CSA approvals for the device, but they may be used for applications which do not require UL/CSA approvals.

^[3] Salt water plastic flange (max. temp. 120°F (49°)) (max. pressure 80 psi) Available only Types FSG2, FYG2, FRG2, FSG*2, FRG*2 1/4" NPSF internal only

NOTE: Use this table only to interpret the catalog number. Some combinations are not available.

Commercial Pressure and Float Switches for Power Circuits

Electromechanical Pressure Switches, Class 9013 Types F and G

Class 9013 Type F Air Compressor Switches

Example: 9013FHG2J27C20

FH	G	2		J27				C20				
Type	Enclosure	Low hp ≤ 1.5 hp	High hp ≥ 2 hp	Fluid Connection	Differential psi	Range psi	Code	psi	Form	Modification		
FH:	G: NEMA 1	2:	22:	¼" NPSF internal	20	40–100	J43:	Off at 80	C20:	Standard pack of 20 devices per box ^[1]		
		3:	—	3/8" NPSF internal	20	40–100	J27:	Off at 100				
		4:	24:	¼" 4-way flange	20	40–100	J37:	Off at 110			G4:	Addition of a second ground screw
		9:	29:	¼" NPT external	20	40–100	J38:	Off at 115				
		12:	32:	¼" NPSF internal	30	70–150	J69:	Off at 120			M1:	Maintained manual cut-out lever (Auto-Off)
		13:	33:	3/8" NPSF internal	30	70–150	J52:	Off at 125				
		14:	34:	¼" 4-way flange	30	70–150	J39:	Off at 135			P:	Pulsation plug (copper) (not field installable)
		19:	39:	¼" NPT external	30	70–150	J68:	Off at 140				
		42:	52:	¼" NPSF internal	40	100–200	J55:	Off at 150			T:	½" conduit bushing— ½" long thread—on left
		44:	54:	¼" 4-way flange	40	100–200	J40:	Off at 155				
		49:	59:	¼" NPT external	40	100–200	J59:	Off at 175			U:	Slip-on connections (load side terminals only)
							J99:	Specify pressure setting				

^[1] Additional bulk packages are available. See Table 7 on page 37.

^[2] Inclusion of B7 or B8 grommets will negate UL/CSA approvals for the device, but they may be used for applications which do not require UL/CSA approvals.

NOTE: Use this table only to interpret the catalog number. Some combinations are not available.

Commercial Pressure and Float Switches for Power Circuits

Electromechanical Pressure Switches, Class 9013 Types F and G

Class 9013 Type G Pressure Switches

Example: 9013GHG2J57PXZC10

GH	G	2	J57	P. X. Z. C10
Type	Enclosure	Fluid Connection	Code psi	Form Modification ^[1]
GH: 200/250 psi	G: NEMA 1	1: 1/8" NPSF internal	J20: 20–40	C10: Standard pack of 10 devices per box GHB, GHG, GSB, GSG
GS: 80 psi	B: NEMA 3R	2: 1/4" NPSF internal	J21: 30–50	E: 3-way lever (On-Auto-Off) not compatible with Form X GHG, GMG, GSG
GM: 35 psi	W: NEMA 4	3: 3/8" NPSF internal	J23: 40–20	H: 1 N.O. / 1 N.C. contact
	R: NEMA 7, 9	4: 1/8" NPSF internal	J24: 40–60	P: Pulsation plug (copper) (not field installable)
		5: 1/4" NPT external	J25: 60–80	R: Reverse action / 2 N.O. contacts
		6: 3/8" NPSF internal	J26: 70–90	U: Slip-on connections (load side terminals only)
			GS J28: 70–100	U2: Slip-on connections (line and load side terminals)
		1: 1/8" NPSF internal	J29: 75–100	X: 2-way pressure release valve (not compatible with Form E) available on GHB, GMG, GSB, GHG, GSG, GHR, GHW, GSR, GSW
		2: 1/4" NPSF internal	J30: 80–100	Z: 1/4" male pipe thread on pressure connection
		3: 3/8" NPSF internal	J31: 90–120	Z16: 1/2" - 14 NPT external, 1/4" - 18 NPT internal
			GM J51: 100–80	
		2: 1/4" NPSF internal	J53: 100–125	
			J54: 110–125	
			J56: 110–150	
			J57: 120–150	
			J58: 125–150	
			J60: 125–175	
			J61: 130–175	
			J50: 135–175	
			J66: 140–170	
			J62: 140–175	
			J63: 145–175	
			J64: 150–120	
			J67: 150–175	
			J65: 215–250	
			J99: Specify pressure setting	

^[1] Cannot order Form R in combination with Form H.

NOTE: Use this table only to interpret the catalog number. Some combinations are not available.

Commercial Pressure and Float Switches for Power Circuits

Electromechanical Pressure Switches, Class 9013 Types F and G

Selection and Specifications

Type FSG, 2-Pole, 2 N.C. Contacts
Degree of Protection IP20, NEMA Type 1

Flange Style

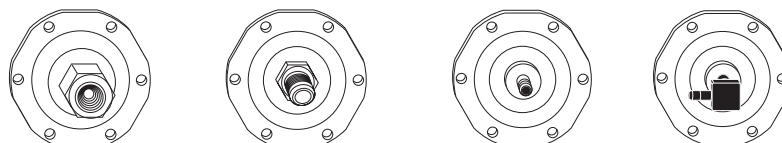

Adjustable range of setting point 20.3–66.7 psi (1.4–4.6 bar)
 Contacts open on rising pressure

Differential	Adjustable			
Fluid Connections	1/4" NPSF internal	1/4" NPT external		
Catalog Numbers				
NEMA Type 1, IP20	9013FSG2	9013FSG9	9013FSG10	9013FSG20
NEMA Type 3R ⁽¹⁾	9013FSW2			
Fluids Controlled	Water	Water	Water	Water
Pressure Range				
Cut-out psig (bar)	20–65 (1.4–4.5)	20–65 (1.4–4.5)	20–65 (1.4–4.5)	20–65 (1.4–4.5)
Cut-in psig (bar)	5–45 (0.3–3.1)	5–45 (0.3–3.1)	5–45 (0.3–3.1)	5–45 (0.3–3.1)
Weight, lb (kg)	0.75 (0.340)	0.75 (0.340)	0.75 (0.340)	0.75 (0.340)
Supplemental Specifications (not shown under General Specifications)				
Differential psig (bar)	15–30 (1.0–2.1)			
Maximum Allowable Pressure psig (bar)	65 (4.5)			
Cable Entry	2 cable entries 0.88 in. (22.4 mm) with 0.84 in. (21.3 mm) across flats			
Pressure Switch Style	Diaphragm			

⁽¹⁾ Must be mounted in a vertical position to maintain enclosure rating.

Ordering information	Pressure codes																								
<ol style="list-style-type: none"> Select the catalog number from the table above. Select the pressure code and add the code designation to the end of the catalog number. Ensure that the pressure code falls within the limits of the device as shown in the device listings. If special features are desired, add the appropriate Form letter to the catalog number after the pressure code. Arrange the Form letters in alphabetical sequence when ordering more than one special feature. Add the packaging code at the end of the sequence, after the Forms. (For example, to order a standard pack of 20 devices, specify 9013FSG2J21MIC20.) If no packaging code is indicated, the devices will be shipped individually packaged. 	<p>NOTE: Existence of a code does not imply that the code is available for any or all devices.</p> <table border="1"> <thead> <tr> <th>Settings (psi)</th> <th>Code</th> </tr> </thead> <tbody> <tr><td>5–21</td><td>J15</td></tr> <tr><td>8–20</td><td>J16</td></tr> <tr><td>20–40</td><td>J20</td></tr> <tr><td>20–50</td><td>J18</td></tr> <tr><td>30–50</td><td>J21</td></tr> <tr><td>40–60</td><td>J24</td></tr> <tr><td>50–70</td><td>J33</td></tr> <tr><td>60–80</td><td>J25</td></tr> <tr><td>Specify pressure settings</td><td>J99</td></tr> <tr><td>Low pressure cut-off (Auto-Start-Off)</td><td>M4 ⁽¹⁾</td></tr> <tr><td>Pulsation plug (standard on FYG4)</td><td>P ⁽²⁾</td></tr> </tbody> </table>	Settings (psi)	Code	5–21	J15	8–20	J16	20–40	J20	20–50	J18	30–50	J21	40–60	J24	50–70	J33	60–80	J25	Specify pressure settings	J99	Low pressure cut-off (Auto-Start-Off)	M4 ⁽¹⁾	Pulsation plug (standard on FYG4)	P ⁽²⁾
Settings (psi)	Code																								
5–21	J15																								
8–20	J16																								
20–40	J20																								
20–50	J18																								
30–50	J21																								
40–60	J24																								
50–70	J33																								
60–80	J25																								
Specify pressure settings	J99																								
Low pressure cut-off (Auto-Start-Off)	M4 ⁽¹⁾																								
Pulsation plug (standard on FYG4)	P ⁽²⁾																								

⁽¹⁾ Low pressure cut-off (Auto-Start-Off) operates at approximately 10 psig below cut-in and will turn off the pump FSG, FYG - (Type 1–20 only) M4

⁽²⁾ Pulsation plug (standard on FYG4) FYG2, 9

Nylon pulsation plug can be field installed on types having 1/4" NPSF internal connector. Catalog number 1530S6G1 is one bag of 50 plugs.



Commercial Pressure and Float Switches for Power Circuits

Electromechanical Pressure Switches, Class 9013 Types F and G

Flange Style

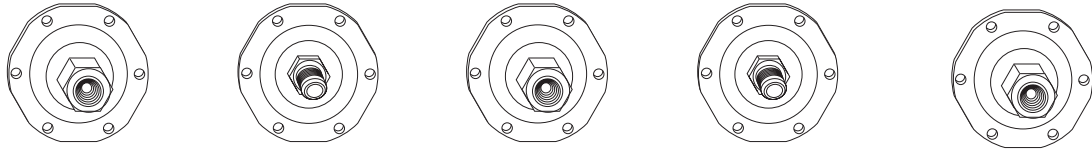

Differential	Adjustable				
Fluid Connections	1/4" NPSF internal	1/4" NPT external	1/4" NPSF internal	1/4" NPT external	
Adjustable range of setting point 20.3–66.7 psi (1.4–4.6 bar)					
Contacts open on rising pressure					
Catalog Numbers					
NEMA Type 1, IP20	9013FSG22	9013FSG29	9013FSG42	9013FSG49	9013FSG52
NEMA Type 3R^[1]	—	9013FSW29	—	—	
Fluids Controlled	Water	Water	Water	Water	Water
Pressure Range					
Cut-out psig (bar)	20–50 (1.4–3.5)	20–60 (1.4–4.2)	9–30 (0.6–2.1)	9–30 (0.6–2.1)	25–80 (1.7–5.5)
Cut-in psig (bar)	10–30 (0.7–2.1)	10–45 (0.7–3.1)	3–10 (0.2–0.7)	3–10 (0.2–0.7)	5–60 (0.3–4.2)
Weight, lb (kg)	0.75 (0.340)	0.75 (0.340)	0.75 (0.340)	0.75 (0.340)	0.75 (0.340)
Supplemental Specifications (not shown under General Specifications)					
Differential psig (bar)	10–30 (0.7–2.1)	10–30 (0.7–2.1)	6–20 (0.4–1.4)	6–20 (0.4–1.4)	20–30 (1.4–2.1)
Maximum Allowable Pressure psig (bar)	50 (3.5)	60 (4.1)	30 (2.1)	30 (2.1)	80 (5.5)
Cable Entry	2 cable entries 0.88 in. (22.4 mm) with 0.84 in. (21.3 mm) across flats				
Pressure Switch Style	Diaphragm				

^[1] Must be mounted in a vertical position to maintain enclosure rating.

Modifications (Forms)

Description	Applies to:	Form letter
Standard pack of 20 devices per box	All Type F	C20 ^[1]
Maintained manual cut-out lever (Auto-Off)	FSG, FYG	M1
Low pressure cut-off (Auto-Start-Off) operates at approximately 10 psig below cut-in and will turn off the pump	FSG, FYG	M4
Maintained manual cut-in lever (Auto-On)	FSG, FYG	M5
Pulsation plug (standard on FSG4)	FSG2, 9	P ^[2]
½" conduit bushing — ½" long thread — on left	All Type F	T
Slip-on connectors (load side terminals only)	FSG, FYG	U
Slip-on connectors (line and load side terminals)	FSG, FYG	U2
Black cover	FSG, FYG	Z22
One grommet, CE mark	All types F	B7 ^[3]
Two grommets, CE mark	All types F	B8 ^[3]
Salt water plastic flange ^[4]	FSG, FYG	Q8

^[1] Additional bulk packages are available. See Table 7 on page 37.

^[2] Nylon pulsation plug can be field installed on types having 1/4" NPSF internal connector.

^[3] Inclusion of B7 or B8 grommets will negate UL/CSA approvals for the device, but they may be used for applications which do not require UL/CSA approvals.

^[4] Salt water plastic flange. (max. temp. 120°F (49°)) (max. pressure 80 psi) Available only Types FSG2, FYG2, FRG2, FSG*2, FRG*2 1/4" NPSF internal only

Catalog number 1530S6G1 is one bag of 50 plugs.



Commercial Pressure and Float Switches for Power Circuits

Electromechanical Pressure Switches, Class 9013 Types F and G

Types FTG, 2-Pole, 2 N.C. Contacts Degree of Protection IP20, NEMA Type 1

Flange Style

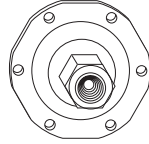

Fixed range of setting point	
Contacts open on rising pressure	
Differential	Fixed
Fluid Connections	1/4" NPSF internal
Catalog Numbers	
NEMA Type 1, IP20	9013FTG2
NEMA Type 3R⁽¹⁾	9013FTW2
Fluids Controlled	Water
Pressure Range	
Cut-out psig (bar)	20–65 (1.4–4.5)
Cut-in psig (bar)	—
Weight, lb (kg)	0.75 (0.340)
Supplemental Specifications (not shown under General Specifications)	
Differential psig (bar)	20 (1.4)
Maximum Allowable Pressure psig (bar)	65 (4.5)
Cable Entry	2 cable entries 0.88 in. (22.4 mm) with 0.84 in. (21.3 mm) across flats
Pressure Switch Style	Diaphragm

⁽¹⁾ Must be mounted in a vertical position to maintain enclosure rating.

Ordering information	Pressure codes	
<ol style="list-style-type: none"> 1. Select the catalog number from the table above. 2. Select the pressure code and add the code designation to the end of the catalog number. Ensure that the pressure code falls within the limits of the device as shown in the device listings. 3. If special features are desired, add the appropriate Form letter to the catalog number after the pressure code. Arrange the Form letters in alphabetical sequence when ordering more than one special feature. 4. Add the packaging code at the end of the sequence, after the Forms. (Sold in lots or multiple of 500; for example: 9013FTG2J21C500.) If no packaging code is indicated, the devices will be shipped individually packaged. 	NOTE: Existence of a code does not imply that the code is available for any or all devices.	
	Settings (psi)	Code
	5–21	J15
	8–20	J16
	20–40	J20
	20–50	J18
	30–50	J21
	40–60	J24
	Specify pressure settings	J99



Commercial Pressure and Float Switches for Power Circuits

Electromechanical Pressure Switches, Class 9013 Types F and G

Types FYG, 2-Pole, 2 N.C. Contacts Degree of Protection IP20, NEMA Type 1

Flange Style



Fixed range of setting point
Contacts open on rising
pressure

Differential	Adjustable	
Fluid Connections	1/4" NPSF internal	
Catalog Numbers		
NEMA Type 1, IP20	9013FYG2	9013FYG42
NEMA Type 3R ⁽¹⁾	9013FYW2	--
Fluids Controlled	Water	
Pressure Range		
Cut-out psig (bar)	25–80 (1.7–5.5)	9–40 (0.6–2.8)
Cut-in psig (bar)	5–60 (0.3–4.2)	3–10 (0.2–0.7)
Weight, lb (kg)	0.75 (0.340)	0.75 (0.340)
Supplemental Specifications (not shown under General Specifications)		
Differential psig (bar)	20–30 (1.4–2.1)	6–20 (0.4–1.4)
Maximum Allowable Pressure psig (bar)	80 (5.5)	40 52;8°
Cable Entry	2 cable entries 0.88 in. (22.4 mm) with 0.84 in. (21.3 mm) across flats	
Pressure Switch Style	Diaphragm	

⁽¹⁾ Must be mounted in a vertical position to maintain enclosure rating.

Ordering information	Pressure codes	
<ol style="list-style-type: none"> Select the catalog number from the table above. Select the pressure code and add the code designation to the end of the catalog number. Ensure that the pressure code falls within the limits of the device as shown in the device listings. If special features are desired, add the appropriate Form letter to the catalog number after the pressure code. Arrange the Form letters in alphabetical sequence when ordering more than one special feature. Add the packaging code at the end of the sequence, after the Forms. (Sold in lots or multiple of 500; for example: 9013FTG2J21C500.) If no packaging code is indicated, the devices will be shipped individually packaged. 	NOTE: Existence of a code does not imply that the code is available for any or all devices.	
	Settings (psi)	Code
	5–21	J15
	8–20	J16
	20–40	J20
	20–50	J18
	30–50	J21
	40–60	J24
	50–70	J33
	60–80	J25
Specify pressure settings	J99	

Commercial Pressure and Float Switches for Power Circuits

Electromechanical Pressure Switches, Class 9013 Types F and G

Type FRG, 1- or 2-Pole, 2 N.O. Contacts Degree of Protection IP20, NEMA Type 1

Flange Style

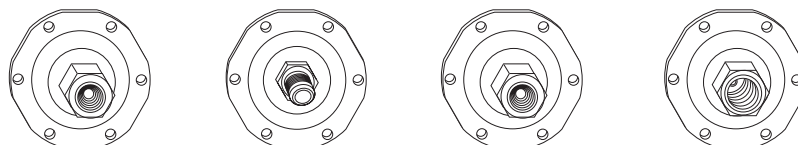

Adjustable range of setting point
Contacts open on rising pressure

Differential	Adjustable			
Fluid Connections	1/4" NPSF internal	1/4" NPT external	1/4" NPSF internal	1/4" NPT external

Adjustable range of setting point 20.3–66.7 psi (1.4–4.6 bar)
Contacts open on rising pressure

Catalog Numbers

1-pole NEMA Type 1, IP20	9013FRG12	--	9013FRG32	9013FRG33
2-pole NEMA Type 1, IP20	9013FRG2	9013FRG9	9013FRG22	9013FRG23
Fluids Controlled	Water	Water	Water	Water

Pressure Range

Cut-out psig (bar)	8–45 (0.6–3.1)	8–45 (0.6–3.1)	4–25 (0.3–1.7)	4–25 (0.3–1.7)
Cut-in psig (bar)	23–65 (1.6–4.5)	23–65 (1.6–4.5)	10–45 (0.7–3.1)	10–45 (0.7–3.1)
Weight, lb (kg)	0.75 (0.340)	0.75 (0.340)	0.75 (0.340)	0.75 (0.340)

Supplemental Specifications (not shown under General Specifications)

Differential psig (bar)	15–30 (1.0–2.1)	15–30 (1.0–2.1)	6–20 (0.4–1.4)	6–20 (0.4–1.4)
Maximum Allowable Pressure psig (bar)	65 (4.5)	65 (4.5)	45 (3.1)	45 (3.1)
Cable Entry	2 cable entries 0.88 in. (22.4 mm) with 0.84 in. (21.3 mm) across flats			
Pressure Switch Style	Diaphragm			

Ordering information

- Select the catalog number from the table above.
- Select the pressure code and add the code designation to the end of the catalog number. Ensure that the pressure code falls within the limits of the device as shown in the device listings.
- If special features are desired, add the appropriate Form letter to the catalog number after the pressure code. Arrange the Form letters in alphabetical sequence when ordering more than one special feature.
- Add the packaging code at the end of the sequence, after the Forms. (For example, to order a standard pack of 20 devices, specify 9013FRG2J21MIC20.) If no packaging code is indicated, the devices will be shipped individually packaged.

Pressure codes

NOTE: Existence of a code does not imply that the code is available for any or all devices.

Settings (psi)	Code
8.5–5.5	J17
10–5	J36
22–12	J22
22–16	J19
35–20	J70
40–20	J23
50–30	J35
80–60	J32
100–80	J51
150–120	J64
Specify pressure settings	J99



Commercial Pressure and Float Switches for Power Circuits

Electromechanical Pressure Switches, Class 9013 Types F and G

Flange Style

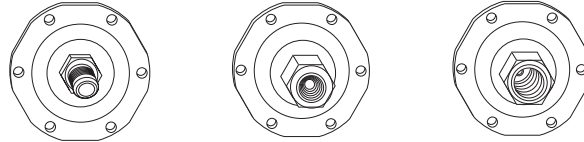

Adjustable range of setting point
Contacts open on falling pressure

Differential	Adjustable	Fixed	Fixed
Fluid Connections	1/4" NPT external	1/4" NPSF internal	3/8" NPSF internal
Catalog Numbers			
1-pole NEMA Type 1, IP20	--	9013FRG52	9013FRG53
2-pole NEMA Type 1, IP20	9013FRG29	9013FRG42	--
Fluids Controlled	Water	Water	Water
Pressure Range			
Cut-out psig (bar)	4–25 (0.3–1.7)	1–11 (0.1–0.8)	1–11 (0.1–0.8)
Cut-in psig (bar)	10–45 (0.7–3.1)	6–14 (0.4–1.0)	6–14 (0.4–1.0)
Weight, lb (kg)	0.75 (0.340)	0.75 (0.340)	0.75 (0.340)
Supplemental Specifications (not shown under General Specifications)			
Differential psig (bar)	6–20 (0.4–1.4)	5 (0.3)	5 (0.3)
Maximum Allowable Pressure psig (bar)	45 (3.1)	14 (1.0)	14 (1.0)
Cable Entry			
Pressure Switch Style			

Modifications (Forms)

Description	Applies to:	Form letter
Standard pack of 20 devices per box	All Type F	C20 ^[1]
1 N.O. / 1 N.C. contact	FRG (2-pole only)	H
Momentary manual cut-in lever (Auto-Start)	FRG2–59 only	M3
Maintained manual cut-in lever (Auto-On)	FRG2–59 only	M5
Pulsation plug	FSG2, 9	P ^[2]
Salt water flange (1/4" NPSF internal only)	All Type F	Q8
1/2" conduit bushing — 1/2" long thread — on left	All Type F	T
Black cover	FSG, FYG, FRG	Z22

^[1] Additional bulk packages are available. See Table 7 on page 37.

^[2] Nylon pulsation plug can be field installed on types having 1/4" NPSF internal connector. Catalog number 1530S6G1 is one bag of 50 plugs.

Commercial Pressure and Float Switches for Power Circuits

Electromechanical Pressure Switches, Class 9013 Types F and G

Type FRG, 1- or 2-Pole, 2 N.O. Contacts Degree of Protection IP20, NEMA Type 1

Flange Style

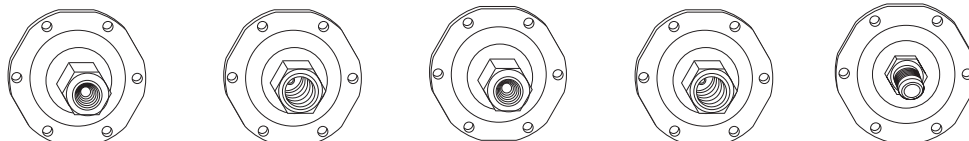

Adjustable range of setting point
Contacts open on falling pressure

Differential	Adjustable				
Fluid Connections	1/4" NPSF internal	3/8" NPSF internal	1/4" NPSF internal	3/8" NPSF internal	1/4" NPT external
Catalog Numbers					
1-pole NEMA Type 1, IP20	9013FRG72	9013FRG73	9013FRG92	9013FRG93	--
2-pole NEMA Type 1, IP20	9013FRG62	9013FRG63	--	--	9013FRG89
Fluids Controlled	Water	Water	Water	Water	Water
Pressure Range					
Cut-out psig (bar)	20–75 (1.4–5.2)	20–75 (1.4–5.2)	35–120 (2.4–8.3)	35–120 (2.4–8.3)	35–120 (2.4–8.3)
Cut-in psig (bar)	40–100 (2.8–6.9)	40–100 (2.8–6.9)	65–150 (4.5–10.3)	65–150 (4.5–10.3)	65–150 (4.5–10.3)
Weight, lb (kg)	0.75 (0.340)	0.75 (0.340)	0.75 (0.340)	0.75 (0.340)	0.75 (0.340)
Supplemental Specifications (not shown under General Specifications)					
Differential psig (bar)	20–30 (1.4–2.1)	20–30 (1.4–2.1)	30–45 (2.1–3.1)	30–45 (2.1–3.1)	30–45 (2.1–3.1)
Maximum Allowable Pressure psig (bar)	100 (6.9)	100 (6.9)	150 (10.3)	150 (10.3)	150 (10.3)
Cable Entry	2 cable entries 0.88 in. (22.4 mm) with 0.84 in. (21.3 mm) across flats				
Pressure Switch Style	Diaphragm				

Ordering information	Pressure codes																								
1. Select the catalog number from the table above.	NOTE: Existence of a code does not imply that the code is available for any or all devices.																								
2. Select the pressure code and add the code designation to the end of the catalog number. Ensure that the pressure code falls within the limits of the device as shown in the device listings.																									
3. If special features are desired, add the appropriate Form letter to the catalog number after the pressure code. Arrange the Form letters in alphabetical sequence when ordering more than one special feature.	<table border="1"> <thead> <tr> <th>Settings (psi)</th> <th>Code</th> </tr> </thead> <tbody> <tr><td>8.5–5.5</td><td>J17</td></tr> <tr><td>10–5</td><td>J36</td></tr> <tr><td>22–12</td><td>J22</td></tr> <tr><td>22–16</td><td>J19</td></tr> <tr><td>35–20</td><td>J70</td></tr> <tr><td>40–20</td><td>J23</td></tr> <tr><td>50–30</td><td>J35</td></tr> <tr><td>80–60</td><td>J32</td></tr> <tr><td>100–80</td><td>J51</td></tr> <tr><td>150–120</td><td>J64</td></tr> <tr><td>Specify pressure settings</td><td>J99</td></tr> </tbody> </table>	Settings (psi)	Code	8.5–5.5	J17	10–5	J36	22–12	J22	22–16	J19	35–20	J70	40–20	J23	50–30	J35	80–60	J32	100–80	J51	150–120	J64	Specify pressure settings	J99
Settings (psi)	Code																								
8.5–5.5	J17																								
10–5	J36																								
22–12	J22																								
22–16	J19																								
35–20	J70																								
40–20	J23																								
50–30	J35																								
80–60	J32																								
100–80	J51																								
150–120	J64																								
Specify pressure settings	J99																								
4. Add the packaging code at the end of the sequence, after the Forms. (For example, to order a standard pack of 20 devices, specify 9013FRG72J23C20.) If no packaging code is indicated, the devices will be shipped individually packaged.																									



Commercial Pressure and Float Switches for Power Circuits

Electromechanical Pressure Switches, Class 9013 Types F and G

Type FHG, 2-Pole, 2 N.C. Contacts Degree of Protection IP20, NEMA Type 1

Flange Style

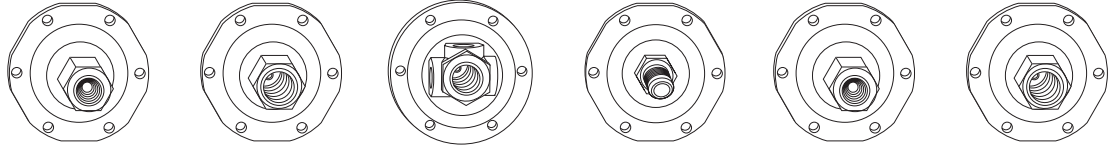

Adjustable range of setting point
Contacts open on rising pressure

Differential	Fixed					
Pressure Connections	1/4" NPSF internal	3/8" NPSF internal	1/4" 4-way Flange	1/4" NPT external	1/4" NPSF internal	3/8" NPSF internal
Catalog Numbers						
Lower hp, 2-pole NEMA Type 1, IP20	9013FHG2	9013FHG3	9013FHG4	9013FHG9	9013FHG12	9013FHG13
Higher hp, 2-pole NEMA Type 1, IP20	9013FHG22	—	9013FHG24	9013FHG29	9013FHG32	9013FHG33
Controls	Air	Air	Air	Air	Air	Air
Pressure Range						
Adjustable cut-out psig (bar)	40–100 (2.8–6.9)	40–100 (2.8–6.9)	40–100 (2.8–6.9)	40–100 (2.8–6.9)	70–150 (4.8–10.3)	70–150 (4.8–10.3)
Weight, lb (kg)	0.75 (0.340)	0.75 (0.340)	0.75 (0.340)	0.75 (0.340)	0.75 (0.340)	0.75 (0.340)
Supplemental Specifications (not shown under General Specifications)						
Differential, Fixed psig (bar)	20 (1.4)	20 (1.4)	20 (1.4)	20 (1.4)	30 (2.1)	30 (2.1)
Maximum Allowable Pressure psig (bar)	100 (6.9)	100 (6.9)	100 (6.9)	100 (6.9)	150 (10.3)	150 (10.3)
Cable Entry	2 cable entries 0.88 in. (22.4 mm) with 0.84 in. (21.3 mm) across flats					
Pressure Switch Style	Diaphragm					

Ordering information	Pressure codes																										
<ol style="list-style-type: none"> Select the catalog number from the table above. Select the pressure code and add the code designation to the end of the catalog number. Ensure that the pressure code falls within the limits of the device as shown in the device listings. If special features are desired, add the appropriate Form letter to the catalog number after the pressure code. Arrange the Form letters in alphabetical sequence when ordering more than one special feature. Add the packaging code at the end of the sequence, after the Forms. (For example, to order a standard pack of 20 devices, specify 9013FHG19J52MIXC20.) If no packaging code is indicated, the devices will be shipped individually packaged. 	<p>NOTE: Existence of a code does not imply that the code is available for any or all devices.</p> <table border="1"> <thead> <tr> <th>Settings (psi)</th> <th>Code</th> </tr> </thead> <tbody> <tr><td>Off at 80</td><td>J43</td></tr> <tr><td>Off at 100</td><td>J27</td></tr> <tr><td>Off at 110</td><td>J37</td></tr> <tr><td>Off at 115</td><td>J38</td></tr> <tr><td>Off at 120</td><td>J69</td></tr> <tr><td>Off at 125</td><td>J52</td></tr> <tr><td>Off at 135</td><td>J39</td></tr> <tr><td>Off at 140</td><td>J68</td></tr> <tr><td>Off at 150</td><td>J55</td></tr> <tr><td>Off at 155</td><td>J40</td></tr> <tr><td>Off at 175</td><td>J59</td></tr> <tr><td>Specify pressure settings</td><td>J99</td></tr> </tbody> </table>	Settings (psi)	Code	Off at 80	J43	Off at 100	J27	Off at 110	J37	Off at 115	J38	Off at 120	J69	Off at 125	J52	Off at 135	J39	Off at 140	J68	Off at 150	J55	Off at 155	J40	Off at 175	J59	Specify pressure settings	J99
Settings (psi)	Code																										
Off at 80	J43																										
Off at 100	J27																										
Off at 110	J37																										
Off at 115	J38																										
Off at 120	J69																										
Off at 125	J52																										
Off at 135	J39																										
Off at 140	J68																										
Off at 150	J55																										
Off at 155	J40																										
Off at 175	J59																										
Specify pressure settings	J99																										

Commercial Pressure and Float Switches for Power Circuits

Electromechanical Pressure Switches, Class 9013 Types F and G

Flange Style

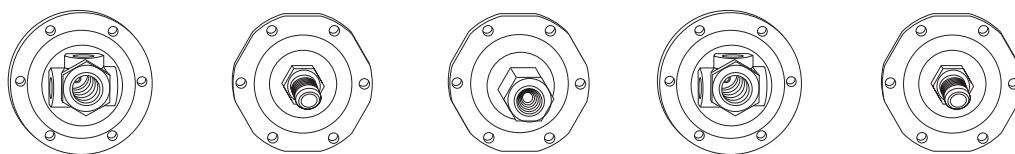

Adjustable range of setting point
Contacts open on rising pressure

Differential	Fixed				
Pressure Connections	4-way Flange	1/4" NPT external	1/4" 4-way Flange	1/4" 4-way Flange	1/4" 4-way Flange
Catalog Numbers					
Lower hp, 2-pole NEMA Type 1, IP20	9013FHG14	9013FHG19	9013FHG42	9013FHG44	9013FHG49
Higher hp, 2-pole NEMA Type 1, IP20	9013FHG34	9013FHG39	9013FHG52	9013FHG54	9013FHG59
Controls	Air	Air	Air	Air	Air
Pressure Range					
Adjustable cut-out psig (bar)	70–150 (4.8–10.3)	70–150 (4.8–10.3)	100–200 (6.9–13.8)	100–200 (6.9–13.8)	100–200 (6.9–13.8)
Weight, lb (kg)	0.75 (0.340)	0.75 (0.340)	0.75 (0.340)	0.75 (0.340)	0.75 (0.340)
Supplemental Specifications (not shown under General Specifications)					
Differential, Fixed psig (bar)	30 (2.1)	30 (2.1)	40 (2.8)	40 (2.8)	40 (2.8)
Maximum Allowable Pressure psig (bar)	150 (10.3)	150 (10.3)	200 (13.8)	200 (13.8)	200 (13.8)
Cable Entry	2 cable entries 0.88 in. (22.4 mm) with 0.84 in. (21.3 mm) across flats				
Pressure Switch Style	Diaphragm				

Modifications (Forms)

NOTE: Modifications G4 and Z22 can be field installed, all others are factory installed only.

Description	Form letter
Standard pack of 20 devices per box	C20 ⁽¹⁾
Addition of a second ground screw	G4
Maintained manual cut-out lever (Auto-Off)	M1
Pulsation plug (copper)	P
½" conduit bushing—½" long thread — on left	T
Slip-on connectors (load side terminals only)	U
Slip-on connectors (line and load side terminals)	U2
Factory sealed range stud	W
Two-way pressure release valve	X
Quick connect two-way pressure release valve (for use with Polyflow Tubing)	X1
Black cover	Z22

⁽¹⁾ Additional bulk packages are available. See Table 7 on page 37 on following page.

Commercial Pressure and Float Switches for Power Circuits

Electromechanical Pressure Switches, Class 9013 Types F and G

Table 7: Bulk Package Form Numbers for 9013F Pressure Switches

Description	Bulk Package Quantity	20	50
Product without Forms M1, M3, M4, M5, T, X1	9013FHG (without 1/4" four-way)	C20	C50
	9013FHG4, 14, 24, 34, 44, 54 (with 1/4" 4-way flange)	C20	C50
	9013FRG	C20	C50
	9013FSG	C20	C50
	9013FYG	C20	C50

NOTE: other bulk package, please contact the customer care center

Commercial Pressure and Float Switches for Power Circuits

Electromechanical Pressure Switches, Class 9013 Types F and G

Type G, 2-Pole, 2 N.C. Contacts Degree of Protection IP20, NEMA Type 1, 3R, 7, and 9

Flange Style

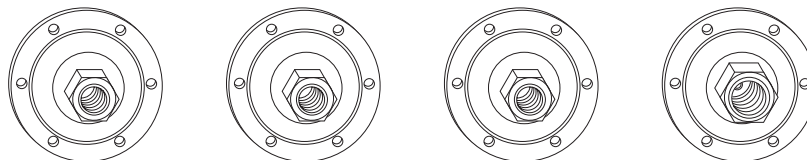

Adjustable range of setting point
Contacts open on rising pressure

Fluid Connections	1/4" NPSF internal	1/4" NPSF internal	1/4" NPSF internal	3/8" NPSF internal
Catalog Numbers				
NEMA Type 1, IP20	9013GMG2	—	9013GSG2	9013GSG3
NEMA Type 3R ⁽¹⁾	—	9013GSB2	—	—
Fluids / Pressure Controls	Water or air	Water or air	Water or air	Water or air
Pressure Range				
Cut-out psig (bar)	10–35 (0.7–2.4)	20–80 (1.4–5.5)	20–80 (1.4–5.5)	20–80 (1.4–5.5)
Cut-in psig (bar)	5.5–30.5 (0.4–2.1)	5–60 (0.4–4.2)	5–60 (0.4–4.2)	5–60 (0.4–4.2)
Weight, lb (kg)	2 (0.91)	2 (0.91)	2 (0.91)	2 (0.91)
Supplemental Specifications (not shown under General Specifications)				
Differential psig (bar)	4–8 (0.3–0.6)	15–30 (1.0–2.1)	15–30 (1.0–2.1)	15–30 (1.0–2.1)
Maximum Allowable Pressure psig (bar)	35 (2.4)	80 (5.5)	80 (5.5)	80 (5.5)
Cable Entry	3 knockouts for 1/2 in. conduit	3 knockouts for 1/2 in. conduit	3 knockouts for 1/2 in. conduit	3 knockouts for 1/2 in. conduit
Pressure Switch Style	Diaphragm			

⁽¹⁾ Must be mounted in vertical position to maintain enclosure rating.

Ordering information	Pressure codes			
<ol style="list-style-type: none"> Select the catalog number from the table above. Select the pressure code and add the code designation to the end of the catalog number. Ensure that the pressure code falls within the limits of the device as shown in the device listings. If special features are desired, add the appropriate Form letter to the catalog number after the pressure code. Arrange the Form letters in alphabetical sequence when ordering more than one special feature. Add the packaging code at the end of the sequence, after the Forms. (For example, to order a standard pack of 10 devices, specify 9013GHG2J99RZC10.) If no packaging code is indicated, the devices will be shipped individually packaged. To order a standard pack of 10 devices per box C10 (available on GHB, GHG, GSB, and GSG) see page 36 for Form C10. 	NOTE: Existence of a code does not imply that the code is available for any or all devices.			
	Settings (psi)	Code	Settings (psi)	Code
	20–40	J20	110–150	J56
	30–50	J21	120–150	J57
	40–20	J23	125–150	J58
	40–60	J24	125–175	J60
	60–80	J25	130–175	J61
	70–90	J26	140–170	J66
	70–100	J28	140–175	J62
	75–100	J29	145–175	J63
	80–100	J30	150–120	J64
	90–120	J31	150–175	J67
	100–80	J51	215–250	J65
	100–125	J53	Specify pressure settings	J99
110–125	J54	—	—	



Commercial Pressure and Float Switches for Power Circuits

Electromechanical Pressure Switches, Class 9013 Types F and G

Flange Style

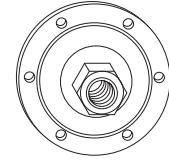
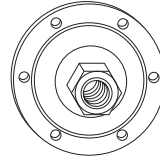
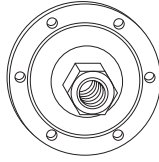

Adjustable range of setting point
Contacts open on rising pressure

Fluid Connections	1/4" NPSF internal	1/4" NPSF internal	1/4" NPSF internal
Catalog Numbers			
NEMA Type 3R	—	—	9013GHB2
NEMA Type 4	—	9013GSW2	—
NEMA Type 7, 9	9013GSR2	—	—
Fluids / Pressure Controls	Water or air	Water or air	Water or air
Pressure Range			
Cut-out psig (bar)	20–80 (1.4–5.5)	20–80 (1.4–5.5)	60–200 (4.1–13.8)
Cut-in psig (bar)	5–50 (0.4–3.5)	5–50 (0.4–3.5)	40–170 (2.8–12)
Weight, lb (kg)	8 (3.62)	8 (3.62)	2 (0.91)
Supplemental Specifications (not shown under General Specifications)			
Differential psig (bar)	20–40 (1.4–2.8)	20–40 (1.4–2.8)	20–40 (1.4–2.8)
Maximum Allowable Pressure psig (bar)	80 (5.5)	80 (5.5)	200 (13.8)
Cable Entry	2 conduit entries 3/4"-14 NTP	2 conduit entries 3/4"-14 NTP	3 knockouts for 1/2 in. conduit
Pressure Switch Style	Diaphragm		

Modifications (Forms)

NOTE: Factory installed only.

Description	Applies to:	Form letter
Standard pack of 10 devices per box	GHB, GHG, GSB, GSG	C10
3-way lever (On-Auto-Off) not compatible with Form X	GHG, GMG, GSG	E
1 N.O. / 1 N.C. contact	All Type G	H ⁽¹⁾
Pulsation plug (copper)	All Type G	P
Reverse action / 2 N.O. contacts	All Type G	R ⁽¹⁾
Slip-on connectors (load side terminals only)	All Type G	U
2-way pressure release valve (not compatible with Form E)	GHB, GMG, GSB, GHG, GSG, GHR, GHW, GSR, GSW	X
1/4" male pipe thread on pressure connection	All Type G	Z
1/2" - 14 NPT external 1/4" - 18 NPT internal	All Type G	Z16

⁽¹⁾ Cannot order Form R in combination with Form H.

Commercial Pressure and Float Switches for Power Circuits

Electromechanical Pressure Switches, Class 9013 Types F and G

Flange Style

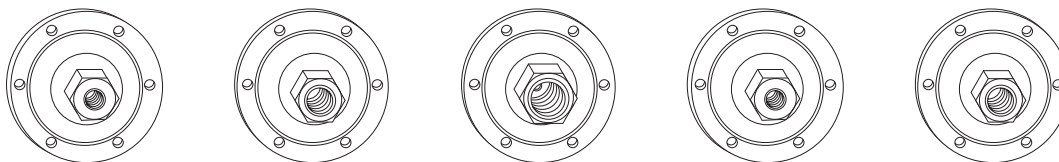

Adjustable range of setting point
Contacts open on rising pressure

Fluid Connections	1/8" NPSF internal	1/4" NPSF internal	3/8" NPSF internal	1/8" NPSF internal	1/4" NPSF internal
--------------------------	--------------------	--------------------	--------------------	--------------------	--------------------

Catalog Numbers

NEMA Type 1, IP20	9013GHG1	9013GHG2	9013GHG3	—	—
NEMA Type 7, 9	—	—	—	9013GHR1	9013GHR2
Fluids / Pressure Controls	Water or air	Water or air	Water or air	Water or air	Water or air

Pressure Range

Cut-out psig (bar)	60–200 (4.1–13.8)	60–200 (4.1–13.8)	60–200 (4.1–13.8)	65–200 (4.5–13.8)	65–200 (4.5–13.8)
Cut-in psig (bar)	40–170 (2.8–12)	40–170 (2.8–12)	40–170 (2.8–12)	35–150 (2.4–10.3)	35–150 (2.4–10.3)
Weight, lb (kg)	2 (0.91)	2 (0.91)	2 (0.91)	8 (3.62)	8 (3.62)

Supplemental Specifications (not shown under General Specifications)

Differential psig (bar)	20–40 (1.4–2.8)	20–40 (1.4–2.8)	20–40 (1.4–2.8)	30–50 (2.1–3.5)	30–50 (2.1–3.5)
Maximum Allowable Pressure psig (bar)	80 (5.5)	80 (5.5)	80 (5.5)	80 (5.5)	80 (5.5)
Cable Entry	3 knockouts for 1/2 in. conduit	3 knockouts for 1/2 in. conduit	3 knockouts for 1/2 in. conduit	2 conduit entries 3/4"-14 NTP	2 conduit entries 3/4"-14 NTP
Pressure Switch Style	Diaphragm				

Ordering information	Pressure codes			
^[1] Select the catalog number from the table above.	NOTE: Existence of a code does not imply that the code is available for any or all devices.			
^[2] Select the pressure code and add the code designation to the end of the catalog number. Ensure that the pressure code falls within the limits of the device as shown in the device listings.	Settings (psi)	Code	Settings (psi)	Code
^[3] If special features are desired, add the appropriate Form letter to the catalog number after the pressure code. Arrange the Form letters in alphabetical sequence when ordering more than one special feature.	20–40	J20	110–150	J56
^[4] Add the packaging code at the end of the sequence, after the Forms. (For example, to order a standard pack of 10 devices, specify 9013GHG2J99RZC10.) If no packaging code is indicated, the devices will be shipped individually packaged. To order a standard pack of 10 devices per box C10 (available on GHB, GHG, GSB, and GSG) see page 36 for Form C10.	30–50	J21	120–150	J57
	40–20	J23	125–150	J58
	40–60	J24	125–175	J60
	60–80	J25	130–175	J61
	70–90	J26	140–170	J66
	70–100	J28	140–175	J62
	75–100	J29	145–175	J63
	80–100	J30	150–120	J64
	90–120	J31	150–175	J67
	100–80	J51	215–250	J65
	100–125	J53	Specify pressure settings	J99
	110–125	J54	—	—



Commercial Pressure and Float Switches for Power Circuits

Electromechanical Pressure Switches, Class 9013 Types F and G

Flange Style

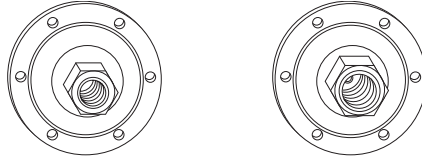

Adjustable range of setting point
Contacts open on rising pressure

Fluid Connections	1/4" NPSF internal	1/4" NPSF internal
Catalog Numbers		
NEMA Type 1, IP20	—	9013GHG5
NEMA Type 4	9013GHW2	—
Fluids / Pressure Controls	Water or air	Water or air
Pressure Range		
Cut-out psig (bar)	65–200 (4.5–13.8)	80–250 (5.5–17.2)
Cut-in psig (bar)	35–150 (2.4–10.3)	32–215 (2.2–14.8)
Weight, lb (kg)	8 (3.62)	2 (0.91)
Supplemental Specifications (not shown under General Specifications)		
Differential psig (bar)	30–50 (2.1–3.5)	25–45 (1.7–3.1)
Maximum Allowable Pressure psig (bar)	200 (13.8)	250 (17.2)
Cable Entry	2 conduit entries 3/4"-14 NTP	3 knockouts for 1/2 in. conduit
Pressure Switch Style	Diaphragm	

Modifications (Forms)

NOTE: Factory installed only.

Description	Applies to:	Form letter
Standard pack of 10 devices per box	GHB, GHG, GSB, GSG	C10
3-way lever (On-Auto-Off) not compatible with Form X	GHG, GMG, GSG	E
1 N.O. / 1 N.C. contact	All Type G	H ⁽¹⁾
Pulsation plug (copper)	All Type G	P
Reverse action / 2 N.O. contacts	All Type G	R ⁽¹⁾
Slip-on connectors (load side terminals only)	All Type G	U
2-way pressure release valve (not compatible with Form E)	GHB, GMG, GSB, GHG, GSG, GHR, GHW, GSR, GSW	X
1/4" male pipe thread on pressure connection	All Type G	Z
1/2" - 14 NPT external 1/4" - 18 NPT internal	All Type G	Z16

⁽¹⁾ Cannot order Form R in combination with Form H.

Commercial Pressure and Float Switches for Power Circuits

Electromechanical Pressure Switches, Class 9013 Types F and G

Flange Style

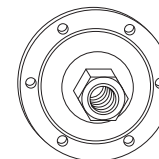
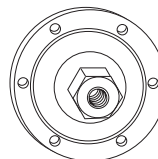
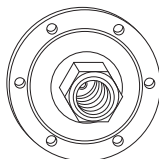

Adjustable range of setting point
Contacts open on rising pressure

Fluid Connections	3/8" NPSF internal	1/8" NPSF internal	1/4" NPSF internal
Catalog Numbers			
NEMA Type 1, IP20	9013GHG6	—	—
NEMA Type 4	—	—	9013GHW5
NEMA Type 7, 9	—	9013GHR4	—
Fluids / Pressure Controls	Water or air	Water or air	Water or air
Pressure Range			
Cut-out psig (bar)	80–250 (5.5–17.2)	80–250 (5.5–17.2)	80–250 (5.5–17.2)
Cut-in psig (bar)	32–215 (2.2–14.8)	30–190 (2.0–13.1)	30–190 (2.0–13.1)
Weight, lb (kg)	2 (0.91)	8 (3.62)	8 (3.62)
Supplemental Specifications (not shown under General Specifications)			
Differential psig (bar)	25–45 (1.7–3.1)	40–60 (2.8–4.1)	40–60 (2.8–4.1)
Maximum Allowable Pressure psig (bar)	250 (17.2)	250 (17.2)	250 (17.2)
Cable Entry	3 knockouts for 1/2 in. conduit	2 conduit entries 3/4"-14 NTP	2 conduit entries 3/4"-14 NTP
Pressure Switch Style	Diaphragm		

Ordering information	Pressure codes			
<ol style="list-style-type: none"> Select the catalog number from the table above. Select the pressure code and add the code designation to the end of the catalog number. Ensure that the pressure code falls within the limits of the device as shown in the device listings. If special features are desired, add the appropriate Form letter to the catalog number after the pressure code. Arrange the Form letters in alphabetical sequence when ordering more than one special feature. Add the packaging code at the end of the sequence, after the Forms. (For example, to order a standard pack of 10 devices, specify 9013GHG2J99RZC10.) If no packaging code is indicated, the devices will be shipped individually packaged. To order a standard pack of 10 devices per box C10 (available on GHG, GHB, GSB, and GSG) see page 36 for Form C10. 	NOTE: Existence of a code does not imply that the code is available for any or all devices.			
	Settings (psi)	Code	Settings (psi)	Code
	20–40	J20	110–150	J56
	30–50	J21	120–150	J57
	40–20	J23	125–150	J58
	40–60	J24	125–175	J60
	60–80	J25	130–175	J61
	70–90	J26	140–170	J66
	70–100	J28	140–175	J62
	75–100	J29	145–175	J63
	80–100	J30	150–120	J64
	90–120	J31	150–175	J67
	100–80	J51	215–250	J65
100–125	J53	Specify pressure settings	J99	
110–125	J54	—	—	



Commercial Pressure and Float Switches for Power Circuits

Electromechanical Pressure Switches, Class 9013 Types F and G

Modifications (Forms)

NOTE: Factory installed only.

Description	Applies to:	Form letter
Standard pack of 10 devices per box	All Type G	C10
3-way lever (On-Auto-Off) not compatible with Form X	GHG, GMG, GSG	E
1 N.O. / 1 N.C. contact	All Type G	H ⁽¹⁾
Pulsation plug (copper)	All Type G	P
Reverse action	All Type G	R ⁽¹⁾
Slip-on connectors (load side terminals only)	All Type G	U
2-way pressure release valve (not compatible with Form E)	GHB, GMG, GSB, GHG, GSG, GHR, GHW, GSR, GSW	X
¼" male pipe thread on pressure connection	All Type G	Z
½" - 14 NPT external ¼" - 18 NPT internal	All Type G	Z16

⁽¹⁾ Cannot order Form R in combination with Form H.

Commercial Pressure and Float Switches for Power Circuits

Electromechanical Pressure Switches, Class 9013 Types F and G

Dimensions

Type F Compressor and Water Pump Pressure Switches

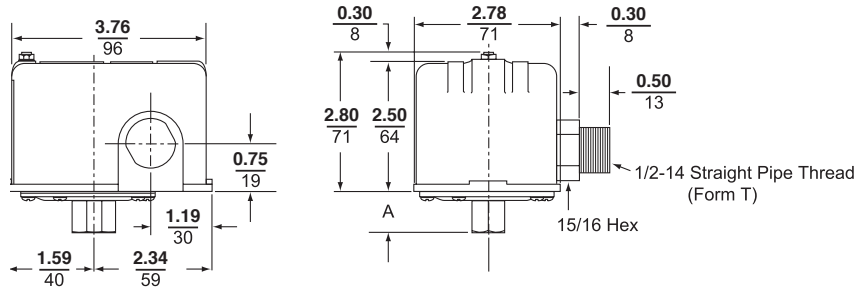

Switch Type	A Dimension, in. (mm)	
FSG1, FYG1	1-1/32	26
FHG2, 12, 22, 32, 42, 52, FRG2, FSG2, FYG2	29/32	23
FHG3, 13, 33, FRG3, FSG3, FYG3	1-9/32	33
FHG9, 19, 29, 39, 49, 59, FSG9, FYG9	1-3/32	28

Type G Compressor and Water Pump Pressure Switches

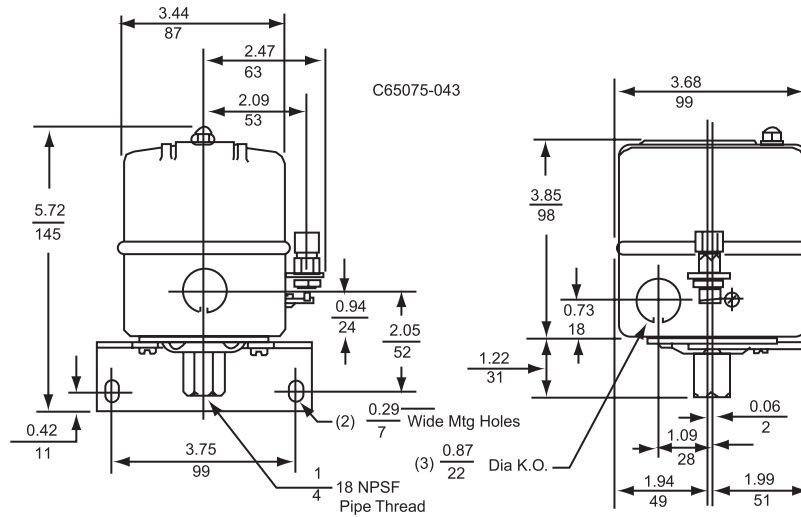

NOTE: Mounting bracket shown is available as a Class 9049 Type A52 Kit.

Switch Type: GHG, GSG (with Form X installed)

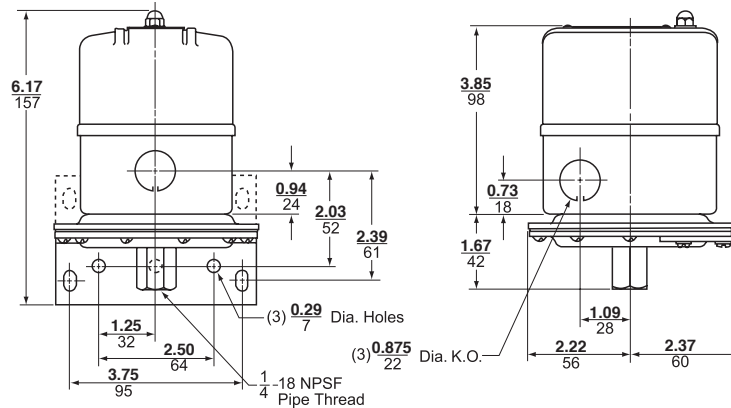

NOTE: Mounting bracket shown is available as a Class 9049 Type A52 Kit.

Switch Type: GMG



Commercial Pressure and Float Switches for Power Circuits

Float Switches — Class 9036, 9037, and 9038

Float Switches — Class 9036, 9037, and 9038

Introduction

Telemecanique Sensors brand offers a wide range of electromechanical level control products.

- Class 9036, Open Tank
- Class 9037, Closed Tank
- Class 9038, Mechanical Alternators



9036DG2R

Class 9036 Open Tank

Type D and G

The Class 9036 Type D and G float switches are lever operated and designed for open tank applications. These switches are floor mounted, or they can be pedestal mounted using mounting plate 9049UMS1. They are available in NEMA Type 1, Type 4, or Type 7 and 9 enclosures.



9036GG2

Type FG

The Class 9036 Type FG30 pedestal-style sump pump switch is designed for liquid level control with electric-motor operated pumps, either directly or through a magnetic starter. It can also be used to activate alarms in liquid level control systems. The upward or downward movement of the lever arm of the float switch controls the On and Off positions corresponding to the water level changes required to turn the pump or alarm on and off.

NOTE: The rod for this device is 33.75 in. long. It cannot be lengthened.



9036FG
9049A60
9049A61

Commercial Pressure and Float Switches for Power Circuits

Float Switches — Class 9036, 9037, and 9038

Class 9037 Closed Tank

Type E



9037E

The Class 9037 Type E switches are flange mounted. Float movement is transmitted through a quad ring seal. Each switch consists of a basic switch, float rod, and float. The switch can be configured in the field for contacts that open on liquid rise or close on liquid rise. These switches are used for top mounted or side mounted, closed tank applications.

Type H



9037HG

The Class 9037 Type H switches are attached to the tank by means of a 2-1/2 in. bushing. An external pointer indicates the float position within the tank when the unit is mounted. Switches come complete with stainless steel float and rod. A nitrile rubber seal, such as a Buna-N quad ring seal, is used between the float rod and the sealing connector. Normal application is at atmospheric pressure. Where higher pressures are encountered, the available Viton® seal allows the switch to withstand tank pressures up to 50 psi at ambient temperatures up to 200 °F. Occasional replacement of the quad ring seal may be necessary.

Class 9038 Mechanical Alternators

Type A (Open Tank)

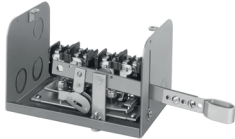

9038AG1

The Class 9038 Type A Open Tank level switch is a mechanical alternator designed to provide motor alternation in the operation of two motors.

Type C (Closed Tank, Bushing Mounted)

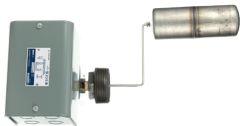

9038CG36

The Class 9038 Type C Closed Tank level switches are bushing mounted. Float movement is transmitted through a quad ring seal. Each switch consists of a basic switch, rod, and float.

Type C switches are attached to the tank by means of a 2-1/2 in. bushing. An external pointer indicates the float position within the tank when the unit is mounted. Switches come complete with bushing, stainless steel float, and rod.

Occasional replacement of the quad ring may be necessary.

Type D (Closed Tank, Flange Mounted, Top)



9038DG
9049ER5
9049EF1

Type D mechanical alternators are designed for applications where flange mounting is to be made at the top of a closed tank.

Commercial Pressure and Float Switches for Power Circuits



9036DG2



9036GG2

Selecting a Float Switch

Standard float switches have two contacts that close when the liquid rises above the designated level. This contact configuration is used for tank emptying applications. Float switches are also available with reverse (Form R) and double throw (Form H) contacts. Form R switches, used for tank filling applications, have two contacts that open when the liquid rises above the designated level. Form H switches, which can be used for both applications, have one normally open (N.O.) and one normally closed (N.C.) contact.

To select the proper Telemecanique Sensors float switch, determine the following:

- Type and shape of tank (open, closed, sump, etc.)
- Enclosure requirements
 - **NEMA Type 1:** For general purpose applications intended for indoor use.
 - **NEMA Type 4:** For watertight and dusttight applications for either indoor or outdoor use.
 - **NEMA Type 7 and 9:** For explosion proof applications. Suitable for Class I, Division 1 and 2, Groups C and D and Class II, Division 1 and 2, Groups E, F, and G hazardous locations.
- Total level change required
- Mounting requirements (such as flange mounting or screw-in bushing)
- Horsepower, phase, and voltage requirements
- Float material
 - Stainless steel (SS)
 - Plastic (available on 9036FG30 and as a Form for use with diesel fuel)
- Rod material
 - Brass
 - Stainless steel (SS)

In direct motor control applications, float switch ratings must be greater than or equal to the pump motor ratings.

NOTE: Contact the Sensor Competency Center when using float switches in liquids with a specific gravity different than water (1.0).

Specify the Class and Type when ordering float switches or accessory kits.

Selecting Floats and Rods

Class 9036 and Class 9038 Type A float switches are actuated with the Class 9049 Type A line of accessories. Select the float and rod material according to the corrosiveness of the liquid used in the application. Two types of float kits are offered:

- Tapped-at-top float (Class 9049 Type A6, A6S)
- Center-hole float (Class 9049 Type A6C, A6CS)

The tapped-at-top float is for applications requiring short lengths of tubing and small liquid level changes. The maximum tubing length is 12 ft (3.66 m). Adequate space must be available to allow for ceiling clearance when the level changes. The float must be buoyant enough to lift the tubing, stop collars, and switch lever. The rod has two stops, one above and one below the switch lever. The position of the stops determines the amount of water level change.



Commercial Pressure and Float Switches for Power Circuits

Float Switches — Class 9036, 9037, and 9038

The center-hole float is used in applications requiring long lengths of tubing and large liquid level changes. A compensating spring, used for longer lengths of tubing, supports the weight of the tubing and stops. When a compensating spring is used, the float must be buoyant enough to lift up the switch lever and heavy enough to trip the switch lever down. The rod has four stops. The position of the stops on the rod above and below the float determines the amount of water level change.

Temperature Ratings

Table 8 : Temperature Limitations for all Float Switches

Ambient	Min.	-22 °F (-30 °C)
	Max.	200 °F (93 °C)

Electrical Ratings

Table 9: Class 9036, 9037, and 9038 Electrical Ratings

Class	Type	Single Phase AC Ratings (hp)			Polyphase AC Ratings (hp)			DC (hp)			Control Circuit Rating
		115 V	230 V	460/575 V	115 V	230 V	460/575 V	32 V	115 V	230 V	
9036	D (2 pole)	2	3	—	3	5	1	0.25	0.5	0.5	A600
	G (2 pole)	2	3	5	3	5	5	0.5	1	1	A600
	G Form H (1 N.O., 1 N.C.)	1	2	2	—	—	—	—	0.5	0.5	A300
9037	E, H (2 pole)	2	3	—	3	5	1	0.25	0.5	0.5	A600
9038	All (2 pole)	2	3	—	3	5	1	0.25	0.5	0.5	A600

The following float switches are UL Listed:

- Class 9036 Types DG, DW, GG, GW
- Class 9037 Types EG, EW, HG, HW
- Class 9038 Types AG, AW, CG, CW, DG, DW

The following float switches are UL Listed for hazardous area:

- Class 9036 Types DR, GR
- Class 9037 Types ER, HR

Table 10: Control Duty Circuit Ratings (Form N5 or N25 only)

Contacts	AC — 50 or 60 Hz						DC			AC or DC Continuous Carrying Amperes
	V	Inductive, 35% Power Factor				Resistive, 75% Power Factor Make and Break Amperes	V	Inductive and Resistive		
		Make		Break				Make and Break Amperes		
		A	VA	A	VA			Single Throw	Double Throw	
SPDT Form N5	120	60	7200	6	720	6	120	0.55	0.22	10
	240	30	7200	3	720	3	250	0.27	0.11	10
	480	15	7200	1.5	720	1.5	600	0.10	—	10
	600	12	7200	1.2	720	1.2	—	—	—	—
DPDT Form N25	120	60	7200	6	720	6	125	0.22	0.22	10
	240	30	7200	3	720	3	250	0.11	0.11	10
	480	15	7200	1.5	720	1.5	600	—	—	10
	600	12	7200	1.2	720	1.2	—	—	—	—



Commercial Pressure and Float Switches for Power Circuits



Float Switches — Class 9036, 9037, and 9038

Class 9036 Type D and G Open Tank Float Switches

Table 11 lists Class 9036 float switches and modifications.

- When ordering a **factory installed modification**, add the Form number to the end of the float switch catalog number. For example, to select a 9036DG2 switch with reverse action, order 9036DG2R.
- **Field installed modifications**, when available, are ordered as kits.

Table 11: Class 9036 Float Switches

Specifications				
Description	2-pole, single-lever operated float switches			
Applications	Open industrial tanks and sump applications			
General Purpose		Heavy Duty		
				
Catalog Numbers				
Contact Action	Close on Liquid Rise	Open on Liquid Rise	Close on Liquid Rise	Open on Liquid Rise
NEMA Type 1 ^[1]	9036DG2	9036DG2R	9036GG2	9036GG2R
NEMA Type 4	9036DW31	9036DW31R	9036GW1 ^[2]	9036GW1R ^[2]
NEMA Type 7, 9	9036DR31	9036DR31R	9036GR1 ^[2]	—
NOTE: A compensating spring supports the weight of long rods that cannot be supported by center-hole floats. A compensating spring is standard on Types GR and GW, and can be ordered as a modification (Form C) on other Class 9036 Type D and G float switches.				
Modifications	Factory Installed		Field Installed	
	Class 9036 Form		Kit Catalog Number	
For Type D (General Purpose)				
Reverse action (Type DG)	R		9049A58	
Compensating spring and reverse action (Types DG, DR, and DW)	CR		—	
For Type G (Heavy Duty)				
Reverse action ^[3]	R		—	
Compensating spring (Type GG) ^[4]	C		9049A13	
1 N.O.–1 N.C. contact configuration	H		—	

^[1] Contact action can be converted in the field by installing the appropriate float rod lever.

^[2] Compensating spring standard. Use center-hole float accessories.

^[3] Type GG is field convertible without the use of a kit. Types GR and GW are not field convertible.

^[4] Compensating spring standard on Types GR and GW.

Commercial Pressure and Float Switches for Power Circuits

Float Switches — Class 9036, 9037, and 9038

Table 12 lists the trip forces and compensating spring requirements for Class 9036 Type D and G float switches. The trip force can be adjusted on the Type G switches by changing the lever length position.

Table 12: Maximum Trip Forces for Class 9036 Float Switches

Class 9036 Type and Form		DG2	DG2R	DW31	DW31R	DR31	DR31R	GG2		GG2R		GR1, GW1		
Lever Length Position		—	—	—	—	—	—	Short	Long	Short	Long	Short	Medium	Long
Force Up to Trip (oz)		9	8	8	8	8	8	33	21	30	22	24	22	20
Force Down to Trip (oz)		8	8	8	8	8	8	39	27	24	16	31	29	27
Maximum Supported Weight (oz)	Without Compensating Spring	6	4	5	5	5	5	25	13	18	11	19	17	16
	With Compensating Spring	60	60	66	66	66	66	[1]	100	[1]	150	80	72	64

^[1] The compensating spring is not effective in combination with short lever length position.

Figure 3: Lever Length

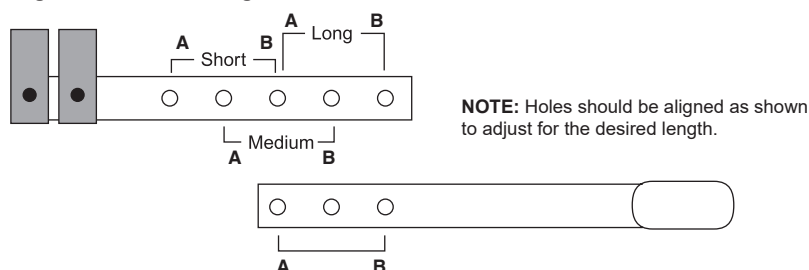

Table 13 lists Class 9049 accessory kits, which are ordered separately from Class 9036 Type D and G float switches. A **float kit** is required; a tubing kit and replacement float do not provide all needed parts.

Table 13: Class 9049 Accessories for Class 9036 Type D and G Float Switches (weight in oz)

Accessory Kits	Tapped-at-Top Floats (#304 SS)		Center-Hole Floats (#304 SS) ^[1]		Additional Tubing (#303 SS) ^[2]	
	All Except GW, GR, and Form C		GW, GR, and Form C		All	
Used on Class 9036 Float Switch Types	All Except GW, GR, and Form C		GW, GR, and Form C		All	
Catalog Number	9049A6	9049A6S	9049A6C	9049A6CS	9049T1	9049T1S
Tubing (rod)	5 ft brass	5 ft SS	5 ft brass	5 ft SS	2.5 ft brass	2.5 ft SS
Net buoyancy in water, 7 in. float ^[3]	60	60	70	70	—	—
Combined weight of stops	3	3	6	6	—	—
Number of stops	2	2	4	4	—	—
Weight of 5 ft rod, included	18.5	16.9	18.5	16.9	—	—
Weight per ft of extra rod	3.7	3.4	3.7	3.4	3.7	3.4

^[1] Require the use of the 9049A6 or 9049A6S kit. The additional tubing only attaches to other lengths of tubing.

^[2] Additional tubing kits add on to the float accessory kits and include a connector. Maximum recommended tubing length: **Tapped-at-top float:** 12.5 ft (3810 mm); **Center-hole float:** 30 ft (9144 mm).

^[3] Net buoyancy calculated with float 80% submerged, allowing for a 20% operating margin. Buoyancy data calculated for use in water. Consult the Sensor Competency Center for buoyancy data in media having specific gravity different than water (1.0).

When ordering, first specify the desired accessory kit, then as a second item give the number of additional tubing kits required. For example, to get a 9049A6C kit with 15 ft of tubing, specify:

- A. 9049A6C, quantity = 1 (includes 5 ft of tubing)
- B. 9049T1, quantity = 4 (2.5 ft of tubing each, for a total of 10 additional ft)

Example	Calculation example	Float buoyancy	70.0 oz
System has 15 ft of brass rod, 4 stops, and a center hole float. Buoyancy is positive, so no compensating spring is required	Measuring 15 ft of tank depth	Total weight	(61.5 oz)
		Weight of stops:	(6.0 oz)
		Weight of 5 ft of brass rod (included):	(18.5 oz)
		Weight of 10 ft of brass rod (separate):	(37.0 oz)
		Buoyancy	8.5 oz

Commercial Pressure and Float Switches for Power Circuits

Float Switches — Class 9036, 9037, and 9038

Figure 4: Type DG Dimensions

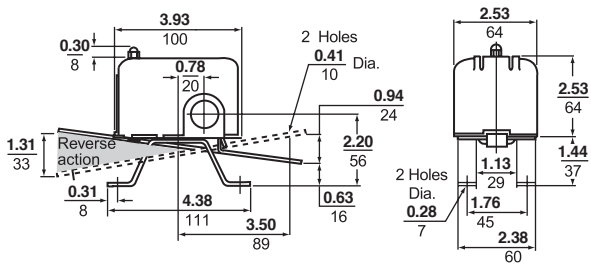

Dual Dimensions: $\frac{\text{in.}}{\text{mm}}$

Figure 5: Types DR/DW Dimensions

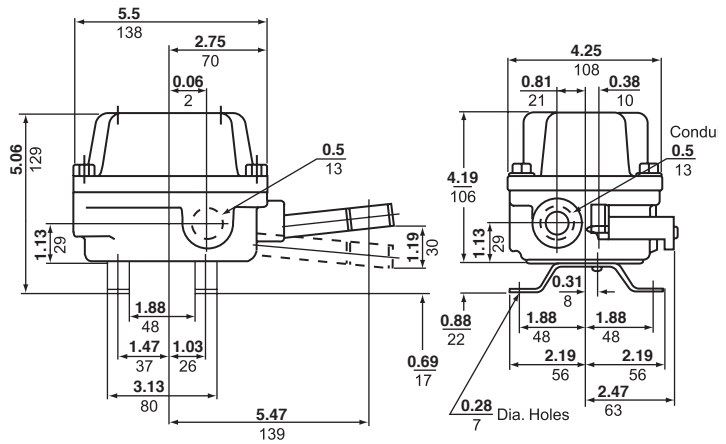
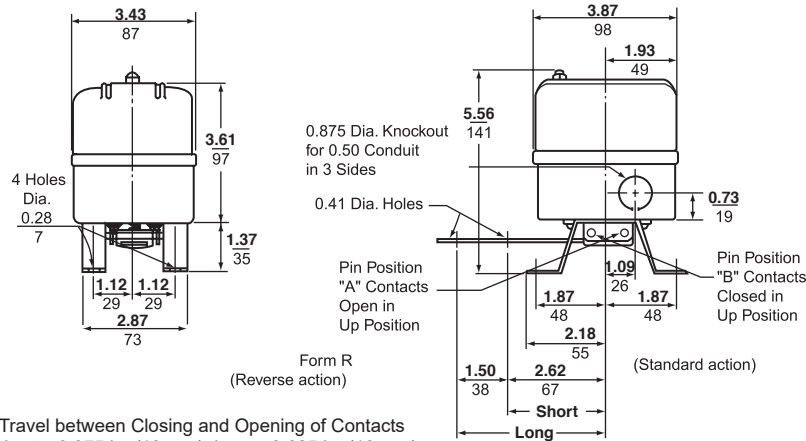
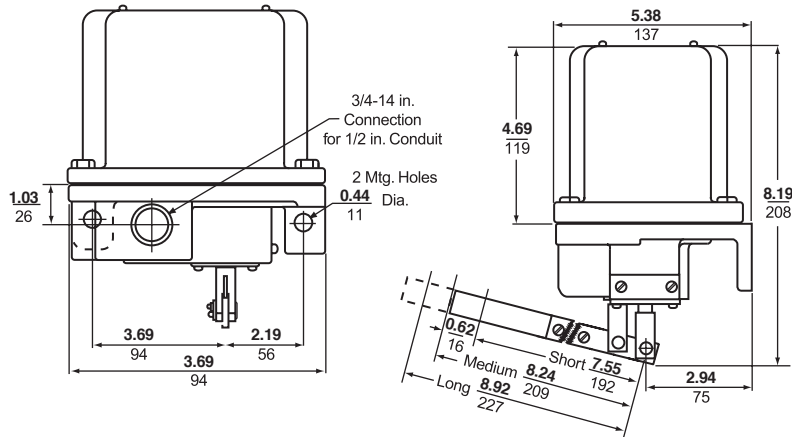

Figure 6: Type GG Dimensions



Lever Arm Travel between Closing and Opening of Contacts
 Standard: short = 0.375 in. (10 mm), long = 0.625 in. (16 mm)
 Form R: short = 0.5 in. (13 mm), long = 0.75 in. (19 mm)

Figure 7: Types GR/GW Dimensions



Float Lever Travel between Closing and Opening of Contacts:
 short = 1 in. (25 mm), medium = 1.12 (28 mm), long = 1.25 in. (31.8)

Commercial Pressure and Float Switches for Power Circuits

Float Switches — Class 9036, 9037, and 9038

Class 9036 Type FG and Class 9049 Accessories

Class 9036 Type FG30 pedestal-style sump pump switches provide:

- Liquid level control with pumps operated by an electric motor, either directly or through a magnetic starter
- Activation of alarms in liquid level control systems
- Forward or reverse action (field selectable)

The upward or downward movement of the lever arm controls the On and Off positions corresponding to the water level changes required to turn the pump or alarm on and off.

Table 14: Class 9036 Type FG30 Pedestal-Style Sump Pump Switch and Accessory Kits



Catalog Number	Pedestal-style Sump Pump Switch		Accessory Kits	
	9036FG30		9049A60	9049A61
Description	2-pole, pedestal-style sump pump switch		Plastic center hole float	33.75 in. aluminum rod, 2 float stop assemblies, and attaching hardware
Quantity Required	1		1	1
NEMA Type	NEMA Type 1		—	—
Contact Action	Contacts close on liquid rise		—	—
Rod Length	—		—	33.75 in. (cannot be lengthened)
Voltage	120/240 Vac		—	—
Horsepower Rating	Single phase	2 hp @ 120 Vac	3 hp @ 240 Vac	—
	Polyphase	3 hp @ 120 Vac	5 hp @ 240 Vac	—



Example:

9036FG
9049A60
9049A61

Commercial Pressure and Float Switches for Power Circuits

Float Switches — Class 9036, 9037, and 9038

Class 9037 Type E Closed Tank Float Switches

Class 9037 closed tank float switches are used primarily on condensate pumps but may also be installed on closed industrial and diesel fuel day tanks. There are two types of Class 9037 float switches:

- Type E (flange mounted)
- Type H (with screw-in bushing)

Class 9037 Type E Flange-Mounted Float Switches

Table 15 contains ordering information for Class 9037 Type E float switches. Order the rod and float accessory kits separately. Contact the Sensor Competency Center when using Class 9037 float switches in liquids with a different specific gravity than water (1.0).

Table 15: Class 9037 Type E Float Switches

Specifications		
Application	Closed industrial tanks Flange mounted	
Float movement	Transmitted through a quad ring seal, which may need occasional replacement	
Tank Pressure	Up to 50 psi	
Temperature	Ambient	Up to 200 °F
	Media	Buna-N seal: up to 215 °F. Viton® seal: up to 250 °F.
Contact Operation	Determined by the float and rod mounting position	
Float Travel	Determined by the post length	

Float Position 1

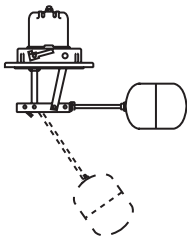

Float Position 2

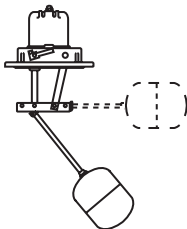

Float Position 3

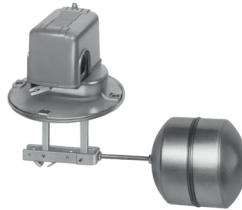
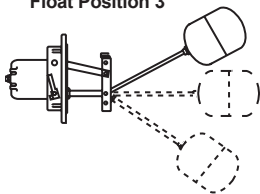

Catalog Numbers

Post Length (L), in. (mm)	2.63 (67)		4.69 (119)	
	Minimum	Maximum	Minimum	Maximum
Water Level Change				
NEMA 1	9037EG8	9037EG9	9037EG10	9037EG13
NEMA 4	--	9037EW9	--	9037EW13
NEMA 7, 9	--	9037ER9	--	
Float Position⁽¹⁾	1	1, 2, 3	1	1, 2, 3

Float Kits

Material	Catalog Number
#304 Stainless Steel	9049EF1
#316 Stainless Steel	9049EF2

⁽¹⁾ For more information on float position, refer to pages 50–51.

For rod kit catalog numbers, refer to pages 50 and 51.

To receive all components packaged in a single carton, specify:

- Float switch Class, Type, and Form
- “R” and the rod number
- “F” and the float number

For example, to receive one each of 9037EG8, 9049ER1, and 9049EF1, specify **9037EG8R1F1**



Commercial Pressure and Float Switches for Power Circuits

Float Switches — Class 9036, 9037, and 9038

Figure 8: Type EG Dimensions

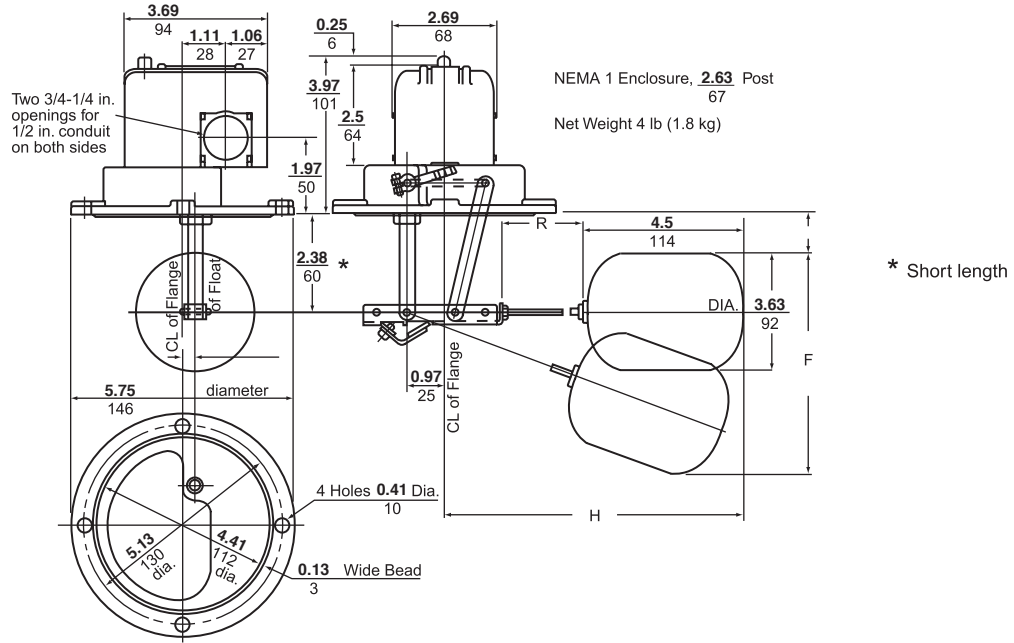
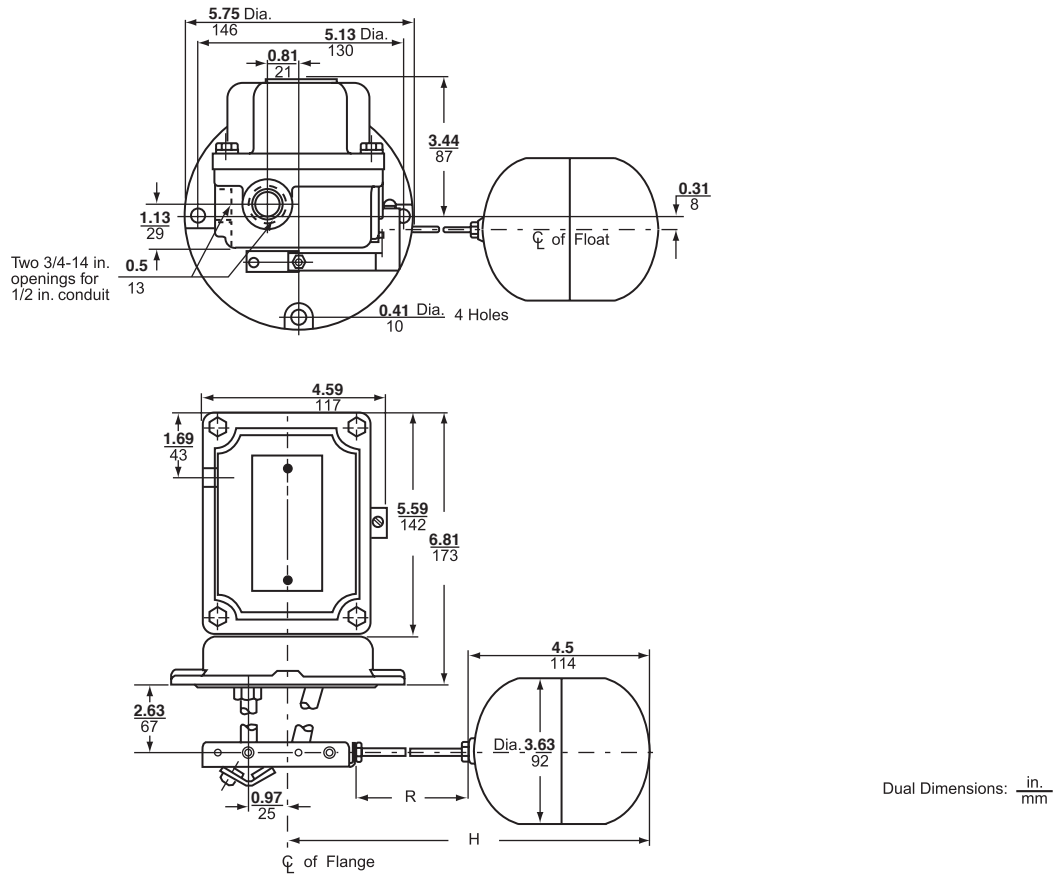

Figure 9: Type ER/EW Dimensions



Commercial Pressure and Float Switches for Power Circuits

Float Switches — Class 9036, 9037, and 9038

Class 9037 Type E Closed Tank Rod Kits

Position 1 Operation

In Position 1, the contacts *close* when the liquid rises. Select rod kits from Table 16.

Table 16: Class 9049 Rod Kits—Position 1 Operation (Contacts *Close* on Liquid Rise)

Catalog Numbers		Rod Kits						
Dimension in. (mm)	For Use on Float Switch Types	9049ER1	9049ER2	9049ER3	9049ER5	9049ER7	9049ER12	
R	EG8, EW8, ER8, EG10, EW10, ER10	1.75 (44)	2.5 (64)	3.25 (83)	5.25 (133)	7.25 (184)	12.25 (311)	
	EG9, EW9, ER9, EG13, EW13, ER13	1.75 (44)	2.5 (64)	3.25 (83)	5.25 (133)	7.25 (184)	12.25 (311)	
H	EG8, EW8, ER8, EG10, EW10, ER10	8.25 (210)	9 (229)	9.5 (241)	11.75 (298)	13.75 (349)	18.75 (476)	
	EG9, EW9, ER9, EG13, EW13, ER13	7.5 (191)	8.25 (210)	9 (229)	11 (279)	12 (305)	18 (457)	
A	Min.	EG8, EW8, ER8	1 (25)	1 (25)	1 (25)	1 (25)	1 (25)	1 (25)
		EG9, EW9, ER9	1 (25)	1 (25)	1 (25)	1 (25)	1 (25)	1 (25)
		EG10, EW10, ER10	3.06 (78)	3.06 (78)	3.06 (78)	3.06 (78)	3.06 (78)	3.06 (78)
		EG13, EW13, ER13	3.06 (78)	3.06 (78)	3.06 (78)	3.06 (78)	3.06 (78)	3.06 (78)
	Max.	EG8, EW8, ER8	2 (51)	2 (51)	2 (51)	2.5 (64)	3 (76)	4.25 (108)
		EG9, EW9, ER9	4 (102)	4.5 (114)	5 (127)	6 (152)	7.5 (191)	9.5 (241)
		EG10, EW10, ER10	4.06 (103)	4.06 (103)	4.06 (103)	4.56 (116)	5.06 (129)	6.31 (160)
		EG13, EW13, ER13	6.06 (154)	6.56 (167)	7.06 (179)	8.06 (205)	9.56 (243)	11.56 (294)
F	Min.	EG8, EW8, ER8, EG10, EW10, ER10	4.75 (121)	4.75 (121)	4.75 (121)	4.75 (121)	5 (127)	5.75 (146)
		EG9, EW9, ER9, EG13, EW13, ER13	6 (152)	6.25 (159)	6.25 (159)	6.5 (165)	6.5 (165)	9 (229)
	Max.	EG8, EW8, ER8, EG10, EW10, ER10	6 (152)	6.25 (159)	6.5 (165)	6.75 (171)	7.25 (184)	9 (229)
		EG9, EW9, ER9, EG13, EW13, ER13	9 (229)	9.75 (248)	10.25 (260)	11.5 (292)	13 (330)	17.5 (445)
Water Level Change	Min.	EG8, EW8, ER8, EG10, EW10, ER10	1.75 (44)	1.75 (44)	1.75 (44)	1.75 (44)	2 (51)	2.75 (70)
		EG9, EW9, ER9, EG13, EW13, ER13	3 (76)	3.25 (83)	3.25 (83)	3.5 (89)	3.5 (89)	6 (152)
	Max.	EG8, EW8, ER8, EG10, EW10, ER10	3 (76)	3.25 (83)	3.5 (89)	3.75 (95)	4.25 (108)	6 (152)
		EG9, EW9, ER9, EG13, EW13, ER13	6 (152)	6.75 (171)	7.25 (184)	8.5 (216)	10 (254)	14.5 (368)

Figure 10: Float Position 1

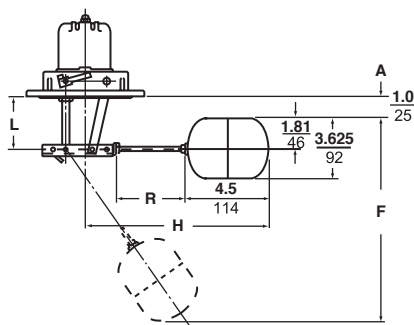

Figure 11: Float Position 2

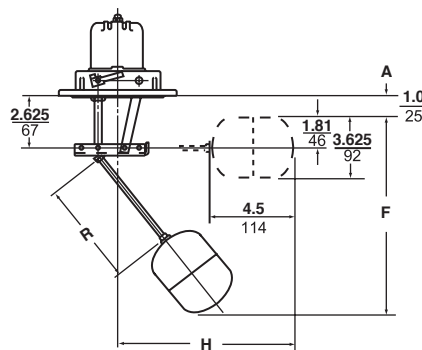
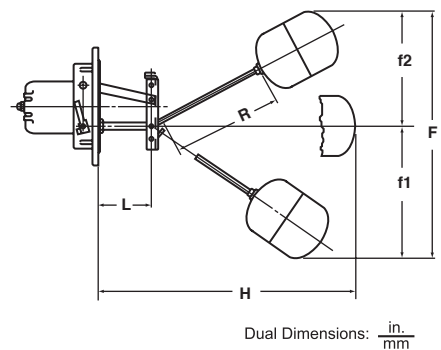

Figure 12: Float Position 3



Commercial Pressure and Float Switches for Power Circuits

Float Switches — Class 9036, 9037, and 9038

Position 2 Operation

In Position 2, the contacts *open* when the liquid rises. Select rod kits from Table 17.

Table 17: Class 9049 Rod Kits — Position 2 Operation (Contacts *Open* on Liquid Rise)

Catalog Numbers		Rod Kits					
Dimension in. (mm)	For Use on Float Switch Types	9049ER1	9049ER2	9049ER3	9049ER5	9049ER7	9049ER12
R	EG9, EW9, ER9, EG13, EW13, ER13	1.75 (44)	2.50 (64)	3.25 (83)	5.25 (133)	7.25 (184)	12.25 (311)
H	EG9, EW9, ER9, EG13, EW13, ER13	7.50 (191)	8.25 (210)	9.00 (229)	11.00 (279)	13.00 (330)	18.00 (457)
A	Min.	EG9, EW9, ER9	1.00 (25)	1.00 (25)	1.00 (25)	1.00 (25)	1.00 (25)
		EG13, EW13, ER13	3.06 (78)	3.06 (78)	3.06 (78)	3.06 (78)	3.06 (78)
	Max.	EG9, EW9, ER9	3.00 (76)	3.50 (89)	4.00 (102)	5.00 (127)	6.00 (152)
		EG13, EW13, ER13	5.06 (129)	5.56 (141)	6.06 (154)	7.06 (179)	8.06 (205)
F	Min.	EG9, EW9, ER9, EG13, EW13, ER13	5.25 (133)	5.75 (146)	6.00 (152)	6.75 (171)	7.75 (197)
	Max.	EG9, EW9, ER9, EG13, EW13, ER13	7.25 (184)	8.25 (210)	9.00 (229)	10.75 (273)	12.75 (324)
Water Level Change	Min.	EG9, EW9, ER9, EG13, EW13, ER13	2.75 (70)	2.75 (70)	3.00 (76)	3.75 (95)	4.75 (121)
	Max.	EG9, EW9, ER9, EG13, EW13, ER13	4.25 (108)	5.25 (133)	6.00 (152)	7.75 (197)	9.00 (229)

Position 3 Operation

In Position 3, the contacts can be set to open (standard) or close (sump) on liquid rise by turning the control switch 180° around its horizontal center line. Select rod kits from Table 18.

Table 18: Class 9049 Rod Kits—Position 3 Operation (Contact Operation Adjustable)

Catalog Numbers		Rod Kits					
Dimension in. (mm)	For Use on Float Switch Types	9049ER1	9049ER2	9049ER3	9049ER5	9049ER7	9049ER12
R	EG9, EW9, ER9, EG13, EW13, ER13	1.75 (44)	2.50 (64)	3.25 (83)	5.25 (133)	7.25 (184)	12.25 (311)
H	EG9, EW9, ER9	9.00 (229)	9.75 (248)	10.50 (267)	12.50 (318)	14.50 (368)	19.50 (495)
	EG13, EW13, ER13	11.00 (279)	11.75 (298)	12.50 (318)	14.50 (368)	16.50 (419)	21.50 (546)
f1 or f2	Min.	EG9, EW9, ER9, EG13, EW13, ER13	2.75 (70)	2.75 (70)	3.00 (76)	3.50 (89)	3.75 (95)
	Max.	EG9, EW9, ER9, EG13, EW13, ER13	4.50 (114)	4.50 (114)	5.00 (127)	6.00 (152)	7.00 (178)
F	Min.	EG9, EW9, ER9, EG13, EW13, ER13	5.50 (140)	5.50 (140)	6.00 (152)	7.00 (178)	7.50 (191)
	Max.	EG9, EW9, ER9, EG13, EW13, ER13	9.00 (229)	9.00 (229)	10.00 (254)	12.00 (305)	14.00 (356)
Water Level Change	Min.	EG9, EW9, ER9, EG13, EW13, ER13	2.25 (57)	2.25 (57)	2.75 (70)	3.75 (95)	4.25 (108)
	Max.	EG9, EW9, ER9, EG13, EW13, ER13	5.75 (146)	5.75 (146)	6.75 (171)	8.75 (222)	10.75 (273)

Commercial Pressure and Float Switches for Power Circuits

Float Switches — Class 9036, 9037, and 9038



Class 9037 Type H with Screw-in Bushing

Table 19 contains ordering information for Class 9037 Type H float switches and factory installed modifications. Contact the Sensor Competency Center when using float switches in liquids with a different specific gravity than water (1.0).

When ordering factory installed modifications, add the Form number to the end of the float switch catalog number. For example, to select a 9037HG36 switch with reverse action, order 9037HG36R.

Table 19: Class 9037 Type H Float Switches

Specifications										
Application	Condensate pumps A 2.5 in. cast-iron bushing attaches the float switch to the tank									
Float movement	Transmitted through a nitrile rubber seal such as a Buna-N quad ring. Occasional replacement may be necessary.									
Tank Pressure	Up to 50 psi									
Temperature	Ambient	Up to 200 °F								
	Media	Buna-N seal: up to 215 °F. Viton® seal: media up to 250 °F.								
Contact Operation	Close on liquid rise (standard) Open on liquid rise (Form R)									
Float Travel	Determined by the float rod angle. An external pointer indicates the float position.									
Materials (Standard)	#304 SS float, #316 SS rod, 2.5 in. cast iron bushing, brass sealing connector, Buna-N quad ring packing.									
Catalog Numbers										
Float Rod Angle	45°		90° offset							
Water Level Change Minimum–Maximum, in. (mm)	2.00–5.00 (52–127)		2.50–5.00 (64–127)		3.75–7.00 (95–178)		4.25–8.25 (108–210)		6.00–11.50 (152–292)	
Float Position ^[1]	Left	Right	Left	Right	Left	Right	Left	Right	Left	Right
NEMA Type 1	9037HG34	9037HG33	9037HG36	9037HG35	9037HG38	9037HG37	9037HG30	9037HG39	9037HG32	9037HG31
NEMA Type 4	9037HW34	9037HW33	9037HW36	9037HW35	---	9037HW37	9037HW30	---	9037HW32	9037HW31
NEMA Type 7, 9	---	9037HR33	9037HR36	---	9037HR38	---	9037HR30	---	9037HR32	---
CL to CL in. (mm)	---		3 (76)		4.25 (108)		5 (127)		7 (178)	
Modifications										Form
Omit 2.5 in. bushing										F3
Omit float										L
Reverse action: contacts open on liquid rise										R ^[2]
Viton packing, 5 oz float (diesel fuel, Types HG, HW, HR30, 31, 32, 37, 38, 39 only)										Z19
Viton packing, for media temperature up to 250 °F										Z20
Viton packing, #316 SS float										Z21
Pack of 8 pcs										C8

^[1] Viewed from the front of the switch, facing the indicator scale.

^[2] Type HG is field modifiable. Type HR and HW cannot be modified in the field.

NOTE: For replacement floats, see “Class 9049 Accessories” on page 55.

Commercial Pressure and Float Switches for Power Circuits

Float Switches — Class 9036, 9037, and 9038

Table 20 lists the float travel distances for the screw-in float switches. Refer to Figure 13.

Figure 13: Travel Dimensions

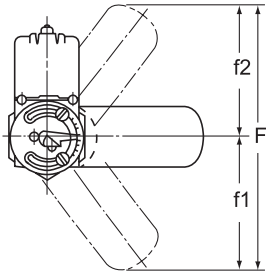

Table 20: Type H Float Travel Distances, in. (mm)

Float Rod Angle	R	H ⁽¹⁾	f1		f2		F	
			Minimum	Maximum	Minimum	Maximum	Minimum	Maximum
45°	—	6.22 (158)	2.25 (57)	4.50 (114)	2.00 (52)	4.50 (110)	4.25 (108)	9.00 (229)
90° offset	3.00 (76)	4.25 (108)	2.75 (70)	4.25 (108)	2.25 (57)	4.25 (108)	5.00 (127)	7.50 (191)
90° offset	4.25 (108)	5.50 (140)	3.50 (89)	5.50 (140)	2.75 (70)	4.00 (102)	6.25 (159)	9.50 (241)
90° offset	5.00 (127)	6.25 (159)	3.75 (95)	6.25 (159)	3.00 (76)	4.50 (110)	6.75 (171)	10.75 (273)
90° offset	7.00 (178)	8.25 (210)	4.75 (121)	8.25 (210)	3.75 (95)	5.75 (146)	8.50 (216)	14.00 (356)

⁽¹⁾ Clearance from centerline of hub to side of tank.

Figure 14: Type HG—45° Angle Dimensions

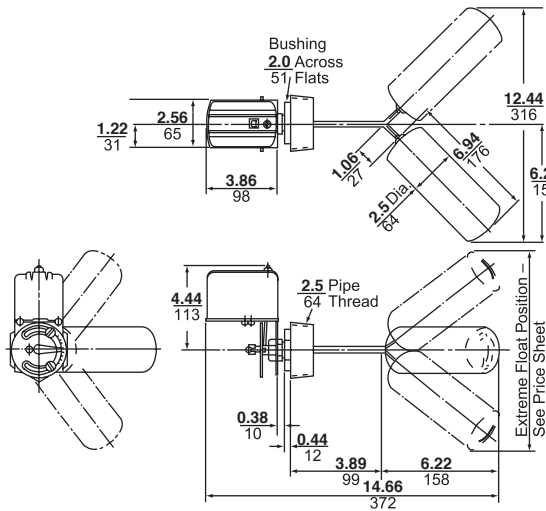

Figure 15: Type HG—90° Offset Dimensions

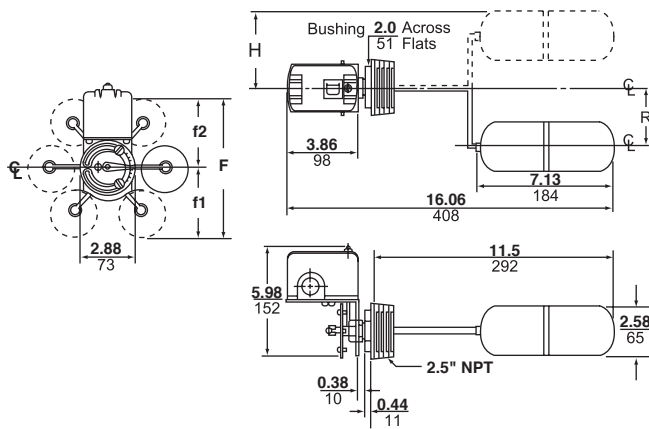

Figure 16: Type HR/HW—45° Angle Dimensions

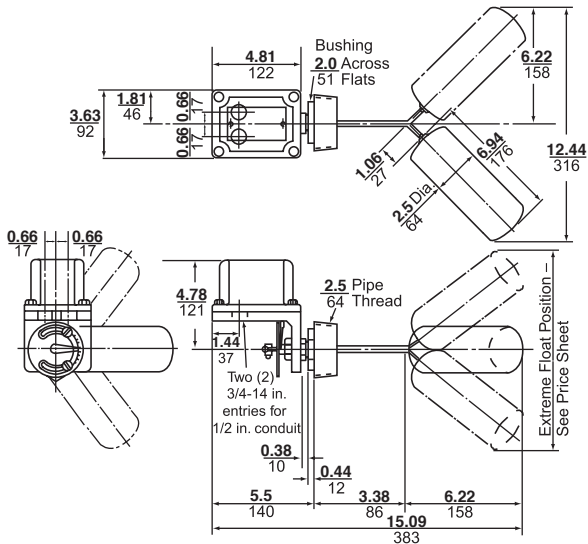
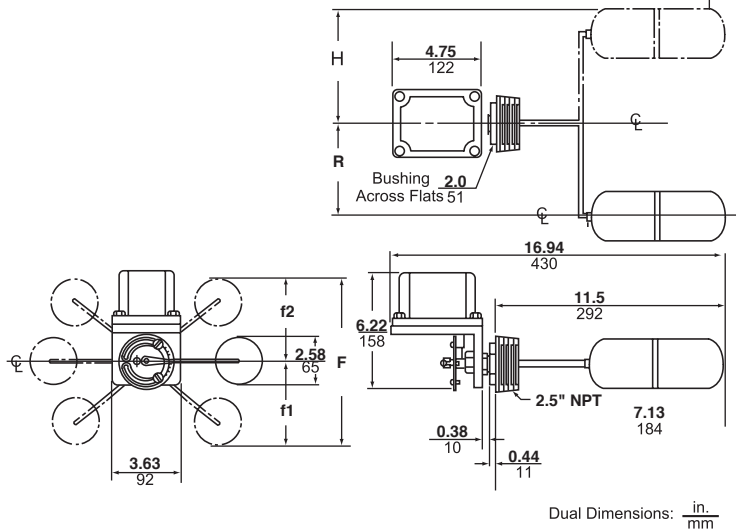

Figure 17: Type HR/HW—90° Offset Dimensions



Dual Dimensions: $\frac{\text{in.}}{\text{mm}}$



Commercial Pressure and Float Switches for Power Circuits

Float Switches — Class 9036, 9037, and 9038

Class 9038 Type A Mechanical Alternators

Class 9038 mechanical alternators provide a simple, positive means of mechanically alternating two pumps or motors. These alternators are used on devices that are installed in a duplex system with a common tank. There are three types of Class 9038 mechanical alternators:

- Type A (open tank and sump)
- Type C (with bushing)
- Type D (flange mounted, vertical)

When liquid level rises to the first level, one pump turns on. Both pumps automatically turn on when a peak condition occurs and the liquid level continues to rise. If Form N5 or N25 is present, and the water level continues to rise, a high water alarm is activated.

Mechanical alternators can be ordered with a manual transfer selector switch (Form N3), which allows the operator to select which pump cuts in first. The second pump only operates under peak demand conditions or if the first pump fails. When the switch is disengaged, the alternator reverts to normal operation. Another option (Form N4) allows the alternator to be used as a two-level non-alternating unit.

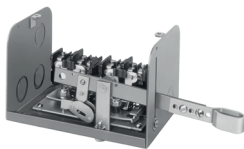

9038AG1

Class 9038 Type A Open and Sump Tank Mechanical Alternators

Table 21 contains ordering information for Class 9038 Type A mechanical alternators, including factory installed modifications. Order float accessories separately. Contact the Sensor Competency Center when using Class 9038 alternators in liquids with a different specific gravity than water (1.0).

When ordering a factory modification, add the Form number to the end of the mechanical alternator catalog number. For example, to select a 9038AG1 alternator with reverse action, order 9038AG1R.

Table 21: Class 9038 Type A Mechanical Alternators

Specifications	
Application	Open and sump tanks using duplex pumps
Float Movement	Float operated
Ambient Temperature	-22 to +200 °F
Contact Operation	Close on liquid rise (standard) Open on liquid rise (Form R)
Catalog Numbers	
NEMA 1	9038AG1
NEMA 4 (compensating spring standard)	9038AW1
NEMA 7, 9 (compensating spring standard)	9038AR1
Modifications	
NOTE: Factory installed only.	Form
Compensating spring (Type AG)	C (field installable)
Two-level, non-alternating unit	N4
High water alarm circuit (single pole)	N5

Commercial Pressure and Float Switches for Power Circuits

Float Switches — Class 9036, 9037, and 9038

Table 22 lists the operating forces for Class 9038 Type A alternators. Use this table when selecting additional tubing or when selecting floats and rods for accessories made by other manufacturers.

Table 22: Class 9038 Type A Operating Forces

Catalog Number	9038AG1		9038AG1R		9038AR1/9038AW1	9038AR1R/9038AW1R	
	Minimum	Maximum	Minimum	Maximum	Standard	Standard	
Lever Length Position							
Force Up to Trip (oz), without Form C ^[1]	18	16	14	11	-	-	
Force Down to Trip (oz), without Form C ^[1]	20	17	16	12	-	-	
Maximum Rod Length Supported by the Compensating Spring ft (m) ^[2]	Brass	10 (3.05)	8 (2.44)	7 (2.13)	6 (1.83)	16 (4.88)	19 (5.79)
	Stainless Steel	12 (3.66)	10 (3.05)	8 (2.44)	7 (2.13)	20 (6.1)	23 (7.01)
Maximum Weight of Tubing and Stops Supported by the Compensating Spring (oz)	47	41	33	30	74	85	

^[1] Add 2 oz for high water alarm (Form N5 or N25).

^[2] Rod length determined using Class 9049 rod material (0.38 in. / 10 mm O.D. tubing).

^[3] Other types of rod must be weighed and compared to the "Maximum Weight of Tubing and Stops" row above.

Accessory Kits

Table 23 lists the Class 9049 accessory kits for Class 9038 Type A alternators. The accessories are ordered separately from the alternators. Order tapped-at-top floats for Type AG1 (except form C) and center-hole floats for Types AG1C, AW1, and AR1.

Table 23: Class 9049 Accessories for Class 9038 Type A Float Switches (weight in oz)

Accessory Kits	Tapped-at-Top Floats (#304 SS)		Center-Hole Floats (#304 SS)		Additional Tubing ^[1]	
	9049A6	9049A6S	9049A6C	9049A6CS	9049T1	9049T1S
Catalog Numbers						
Tubing	5 ft brass	5 ft SS	5 ft brass	5 ft SS	2.5 ft brass	2.5 ft SS
Net buoyancy in water, 7 in. float ^[2]	60	60	70	70	—	—
Total weight of stops	3	3	6	6	—	—
Number of stops	2	2	4	4	—	—
Weight of 5 ft rod, included	18.5	16.9	18.5	16.9	—	—
Weight per ft of extra rod	—	—	—	—	3.7	3.4

^[1] Additional tubing kits add on to the float accessory kits and include a connector. Maximum recommended tubing length for tapped-at-top float: 12.5 ft (3810 mm).

^[2] Net buoyancy calculated with float 80% submerged, allowing for a 20% operating margin. Buoyancy data calculated for use in water. Contact the Sensor Competency Center for buoyancy data in media having specific gravity different than water (1.0).

When ordering float accessories, first specify the desired accessory kit, then as a second item, give the catalog number and the quantity of the additional tubing kits required. For example, for a 9049A6C kit with 15 ft of tubing, specify:

- A. 9049A6C, quantity = 1 (includes 5 ft of tubing)
- B. 9049T1, quantity = 4 (2.5 ft of tubing each, for a total of 10 additional ft)

Figure 18: Type AG1 Dimensions

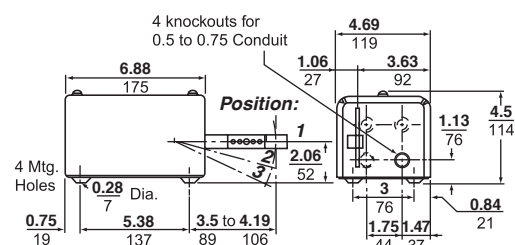
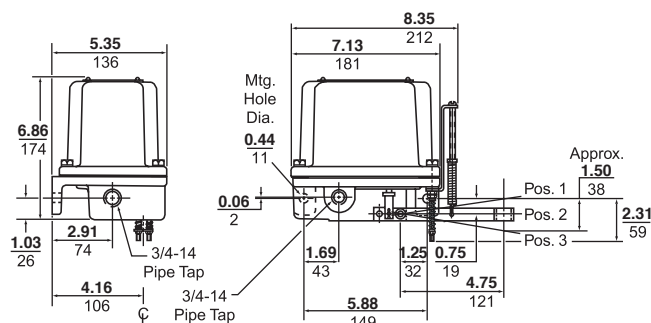

Figure 19: Type AR1/AW1 Dimensions



Commercial Pressure and Float Switches for Power Circuits

Float Switches — Class 9036, 9037, and 9038

Class 9038 Type C Mechanical Alternators with Bushing

Table 24 contains ordering information for Class 9038 Type C mechanical alternators. Contact the Sensor Competency Center when using Class 9038 alternators in liquids with a different specific gravity than water (1.0).

When ordering a factory modification, add the Form number to the end of the alternator catalog number. For example, to select a 9038CG36 alternator with reverse action, select 9038CG36R.

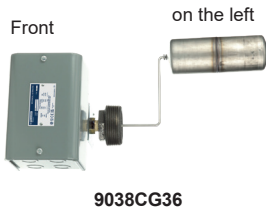

Table 24: Class 9038 Type C Mechanical Alternators Specifications

Specifications	
Application	Closed tanks using duplex, condensate pumps A 2.5 in. cast iron bushing attaches the float switch to the tank
Float movement	Transmitted through a nitrile rubber seal such as a Buna-N quad ring. Occasional seal replacement may be necessary.
Tank Pressure	Up to 50 psi
Ambient Temperature	-22 to +200 °F
Media Temperature (Minimum)	Solidification point of the medium in the tank, down to -22 °F
Contact Operation	Close on liquid rise (standard) Open on liquid rise (Form R)
Float Travel	Float travel is determined by the rod length. An external pointer indicates the float position. For more information on float travel and position, see "Float Travel" on page 61.
Materials (Standard)	#304 SS float, #316 SS rod, 2.5 in. cast iron bushing, brass sealing connector, Buna-N quad ring packing

Catalog Numbers

Float Position ^[1]	Left			Right			
Water Level Change, Minimum–Maximum	in. (mm)	6.5–13 (165–330)	4–7.75 (102–197)	4.75–9.25 (121–235)	6.5–13 (165–330)	4–7.75 (102–197)	4.75–9.25 (121–235)
NEMA 1		9038CG32	9038CG34	9038CG36	9038CG31	9038CG33	9038CG35
NEMA 4		9038CW32	9038CW34	9038CW36	9038CW31	9038CW33	9038CW35
NEMA 7, 9		9038CR32	9038CR34	9038CR36	9038CR31	---	---

Modifications	Form
Omit 2.5 in. cast iron bushing	F3
Omit float	L
Two-level, non-alternating unit	N4 ^[2]
High water alarm circuit, single pole (Type CG only)	N5 ^[2]
High water alarm circuit, two pole (Type CG only)	N25 ^[2]
Reverse action: contacts open on liquid rise	R ^[2]
Fluorocarbon polymer such as Viton® packing, 5 oz float (diesel fuel, Type CG only)	Z19
Fluorocarbon polymer such as Viton packing, for media temperature up to 250 °F	Z20
Fluorocarbon polymer such as Viton packing, #316 SS float for liquid temperatures up to 250 °F	Z21

^[1] Viewed from front of alternator, facing indicator scale.

^[2] Factory installed only.

NOTE: For replacement floats, refer to page 55.



Commercial Pressure and Float Switches for Power Circuits

Float Switches — Class 9036, 9037, and 9038

Table 25 lists the float travel distances for the screw-in float switches. Refer to Figure 20.

Table 25: Type C Float Travel Adjustments, in. (mm)

R	A		B		C		D		F	
	Min.	Max.	Min.	Max.	Min.	Max.	Min.	Max.	Min.	Max.
4.25 (108) ^[1]	2 (51)	3.5 (89)	3.5 (89)	4.75 (121)	2.5 (64)	3.75 (95)	3.5 (89)	4.75 (121)	7 (178)	9.5 (241)
5 (127) ^[2]	2.25 (57)	3.75 (95)	4 (102)	5.25 (133)	2.75 (70)	3 (76)	4 (102)	5.25 (133)	8 (203)	10.5 (267)
7 (178) ^[3]	2.5 (64)	5 (127)	5 (127)	7 (178)	2 (51)	4 (102)	5 (152)	7 (178)	10 (254)	14 (495)

^[1] CG33, CG34, CW33, CW34, CR33, CR34

^[2] CG35, CG36, CW35, CW36, CR35, CR36

^[3] CG31, CG32, CW31, CW32, CR31, CR32

Figure 20: Travel Dimensions

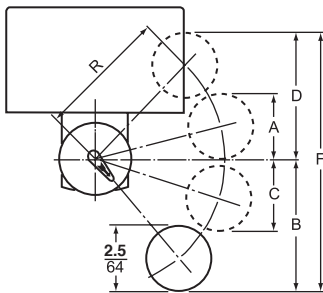

Figure 21: Type CG Dimensions

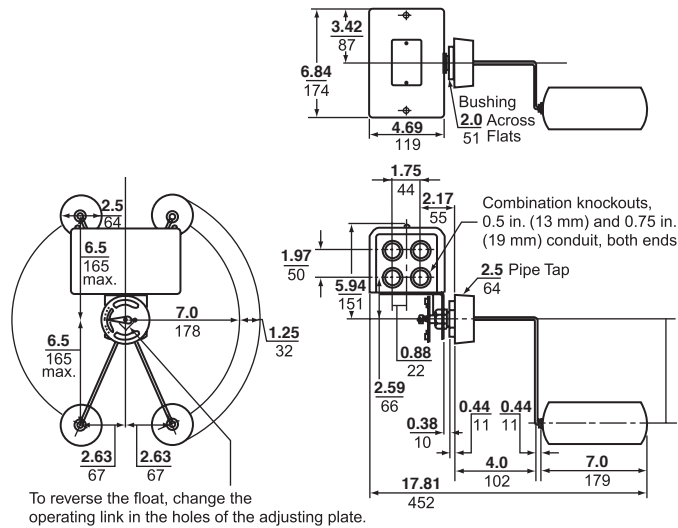
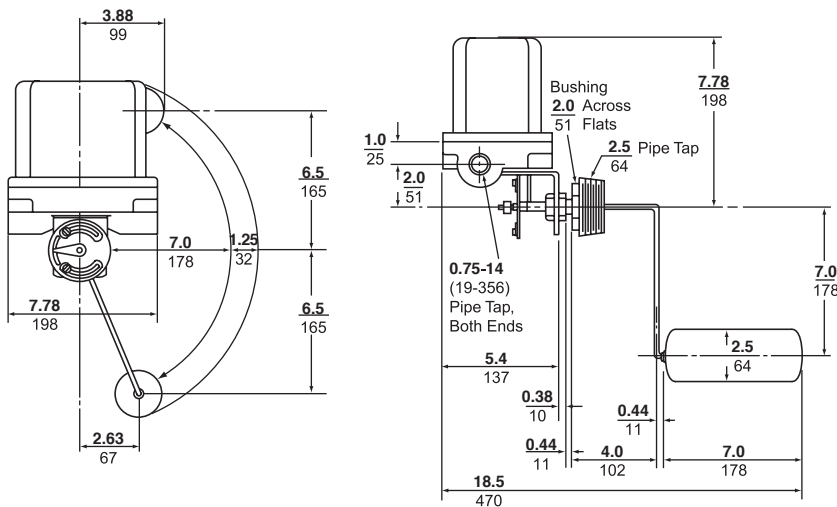

Figure 22: Type CR/CW Dimensions



Commercial Pressure and Float Switches for Power Circuits

Float Switches — Class 9036, 9037, and 9038



9038DG
9049ER5
9049EF1

Class 9038 Type D Flange-Mounted Mechanical Alternators

Flange Mounted

Table 26 contains ordering information for Class 9038 Type D alternators, factory modifications, and float kits. Order rod and float accessory kits separately. Contact the Sensor Competency Center when using Class 9038 alternators in liquids with a different specific gravity than water (1.0).

When ordering a factory modification, add the Form number to the end of the alternator Type number. For example, to select a 9038DG7 alternator with manual transfer, order 9038DG7N3.

Table 26: Class 9038 Type D Mechanical Alternators

Specifications	
Application	Industrial closed tanks using duplex, condensate pumps Top mounted only
Float movement	Transmitted through a quad ring seal (occasional replacement may be necessary)
Tank Pressure	Up to 50 psi
Media Temperature	Viton® seal: up to 250 °F
Contact Operation	Close on liquid rise or open on liquid rise (field reversible)
Float Travel	Determined by the length of the hinge post and rod and by the float position For more information on float travel and position, see "Float Travel" on page 61 the following page.

Catalog Numbers

Hinge Post Length (V) in. (mm)	2.63 (67)		4.69 (119)	
	Minimum	Maximum	Minimum	Maximum
Water Level Change				
NEMA 1	9038DG7	9038DG8	9038DG9	9038DG10
NEMA 4	9038DW7	9038DW8	---	---
NEMA 7, 9	---	9038DR8	---	---

Modifications

NOTE: Factory installed only.

Two-level, non-alternating unit

High water alarm circuit (Type DG only)

Form

N4

N5

Float Kits

Material	Diameter in. (mm)	Length in. (mm)	Catalog Number
#304 stainless steel	3.62 (92)	4.5 (114)	9049EF1
#316 stainless steel	3.62 (92)	4.5 (114)	9049EF2

NOTE: The following float kits are available but are not recommended for use with 9038D mechanical alternators. The float travel dimensions shown in this catalog for 9038D devices do not apply when using these floats. A correction factor appears in the footnote of Tables 27–30 on pages 61 and 63.

#304 stainless steel	2.5 (64)	7 (178)	9049HF3
#316 stainless steel	2.5 (64)	7 (178)	9049HF4

PUMPTROL™

Commercial Pressure and Float Switches for Power Circuits

Float Switches — Class 9036, 9037, and 9038

Class 9049 Rod Kits for Class 9038 Type D

Float Travel

Float travel is determined by the length of the hinge post and rod and by the float position. The float may be operated in three different positions. In Position 1, the contacts close when the liquid rises. In Position 2, the contacts open when the liquid rises. Use Table 27 to select the appropriate rod kit when ordering Class 9038 Types DG7, DW7, or DR7 alternators.

Table 27: Class 9049 Rod Kits for Class 9038 Type DG7, DW7, and DR7 Alternators

Float Travel for Class 9038 Types DG7, DW7, and DR7 Alternators Minimum Water Level Change (V = 2.63 in. / 67 mm)						
Catalog No.	9049ER1	9049ER2	9049ER3	9049ER5	9049ER7	9049ER12
Dimensions in. (mm)						
R	1.75 (44)	2.5 (64)	3.25 (83)	5.25 (133)	7.25 (184)	12.25 (311)
H⁽¹⁾	8.25 (210)	9 (229)	9.5 (241)	11.75 (298)	13.75 (349)	18.75 (476)
A	Min.	0.75 (19)	0.63 (16)	0.5 (13)	0.13 (3)	0.38 (10)
	Max.	0.63 (16)	0.38 (10)	0.25 (6)	0.0 (0)	1.5 (38)
B	Min.	5 (127)	5.38 (137)	5.5 (140)	6.38 (162)	7 (178)
	Max.	5 (127)	5.25 (133)	5.5 (140)	6.25 (159)	7 (178)
C	Min.	4 (102)	4.25 (108)	4.38 (111)	5 (127)	5.5 (140)
	Max.	4.25 (108)	4.5 (114)	4.63 (118)	5.13 (130)	5.75 (146)
D	Min.	1.75 (44)	1.75 (44)	1.75 (44)	1.75 (44)	1.75 (44)
	Max.	1.5 (38)	1.38 (35)	1.25 (32)	1 (25)	0.88 (22)
F	Min.	6.75 (171)	7.13 (181)	7.25 (184)	8.13 (207)	8.75 (222)
	Max.	6.5 (165)	6.63 (168)	6.75 (171)	7.25 (184)	7.88 (200)
G	Min.	1 (25)	1 (25)	1 (25)	1 (25)	1 (25)
	Max.	1.5 (38)	1.5 (38)	1.5 (38)	1.75 (44)	2 (51)

⁽¹⁾Add 2.5 in. (64 mm) to H when using HF3 or HF4 floats.

Figure 23: Travel Dimensions

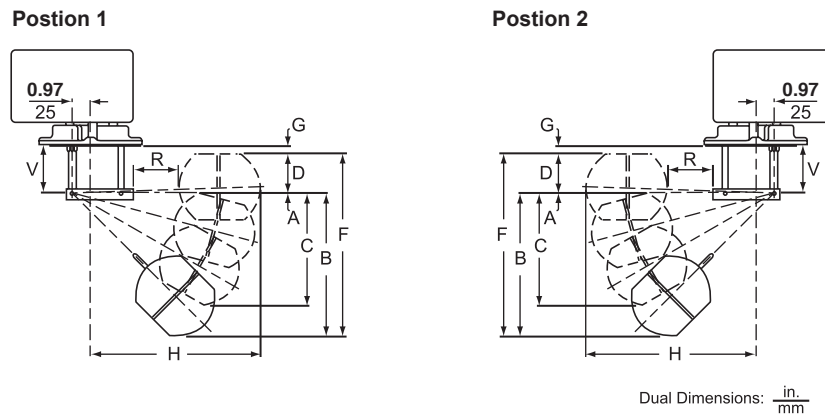

Commercial Pressure and Float Switches for Power Circuits

Float Switches — Class 9036, 9037, and 9038

Use the following table to select the appropriate rod kit when ordering Class 9038 Types DG8, DW8, or DR8 alternators.

Table 28: Class 9049 Rod Kits for Use on Class 9038 Types DG8, DW8, and DR8 Alternators

Float Travel for Class 9038 Types DG8, DW8, and DR8 Alternators Minimum Water Level Change (V = 2.63 in. / 67 mm)							
Catalog No.	9049ER1	9049ER2	9049ER3	9049ER5	9049ER7	9049ER12	
Dimensions in. (mm)							
R	1.75 (44)	2.5 (64)	3.25 (83)	5.25 (133)	7.25 (184)	12.25 (311)	
H ^[1]	7.5 (191)	8.25 (210)	9 (229)	11 (279)	13 (330)	18 (457)	
A	Min.	0.0 (0)	0.5 (13)	1 (25)	2 (51)	3 (76)	5.5 (140)
	Max.	1.25 (32)	1.5 (38)	2 (51)	3 (76)	4 (102)	6.5 (165)
B	Min.	8 (203)	8.75 (222)	9.5 (241)	11.5 (292)	13.5 (343)	18.5 (470)
C	Min.	6.5 (165)	7 (178)	7.75 (197)	9.5 (241)	11 (279)	14.75 (375)
	Max.	6.5 (165)	7 (178)	7.5 (1910)	9 (229)	10.75 (273)	15 (381)
D ^[2]	Min.	2 (51)	1.75 (44)	1.5 (38)	1.25 (32)	0.75 (19)	0.5 (13)
	Max.	0.5 (13)	0.25 (6)	0.0 (0)	0.75 (19)	1.75 (44)	4.25 (108)
F	Min.	10 (254)	10.5 (267)	11 (279)	12.75 (324)	14.25 (362)	19 (483)
	Max.	8.5 (216)	9 (229)	9.5 (241)	10.75 (273)	11.75 (298)	14.25 (362)
G	Min.	1.5 (38)	1.5 (38)	1.75 (44)	2 (51)	2 (51)	2.25 (57)
	Max.	2.5 (64)	2.75 (70)	3 (76)	3.75 (95)	4.5 (114)	6.25 (159)

^[1] Add 2.5 in. (64 mm) to H when using HF3 or HF4 floats.

^[2] D is negative when the top of the float is below the horizontal centerline.

Use the following table to select the appropriate rod kit when ordering Class 9038 Types DG9, DW9, or DR9 alternators.

Table 29: Class 9049 Rod Kits for Class 9038 Type DG9, DW9, and DR9 Alternators

Float Travel for Class 9038 Types DG9, DW9, and DR9 Alternators Minimum Water Level Change (V = 4.69 in. / 119 mm)							
Catalog No.	9049ER1	9049ER2	9049ER3	9049ER5	9049ER7	9049ER12	
Dimensions in. (mm)							
R	1.75 (44)	2.5 (64)	3.25 (83)	5.25 (133)	7.25 (184)	12.25 (311)	
H ^[1]	8.25 (210)	9 (229)	9.5 (241)	11.75 (298)	13.75 (349)	18.75 (476)	
A	Min.	1 (25)	1 (25)	0.88 (22)	0.63 (16)	0.25 (6)	0.13 (3)
	Max.	0.5 (13)	0.13 (3)	0.0 (0)	0.88 (22)	1.63 (41)	2.88 (73)
B	Min.	5.25 (133)	5.75 (146)	6 (152)	7.25 (184)	8.25 (210)	10.75 (273)
	Max.	5.25 (133)	5.63 (143)	5.88 (149)	7.13 (181)	8.25 (210)	11 (279)
C	Min.	4.5 (114)	4.75 (121)	5 (127)	5.75 (146)	6.5 (165)	8.38 (213)
	Max.	4.5 (114)	4.75 (121)	5 (127)	5.88 (149)	6.75 (171)	8.5 (216)
D	Min.	2 (51)	2 (51)	2 (51)	2 (51)	1.88 (48)	1.63 (41)
	Max.	1.5 (38)	1.25 (32)	1.13 (29)	0.75 (19)	0.5 (13)	0.5 (13)
F	Min.	7.25 (184)	7.75 (197)	8 (203)	9.25 (235)	10.13 (257)	12.38 (314)
	Max.	6.75 (171)	6.88 (175)	7 (178)	7.88 (200)	8.75 (222)	11.5 (292)
G	Min.	3 (76)	3 (76)	3 (76)	3 (76)	3.25 (83)	4 (102)
	Max.	3.75 (95)	4 (102)	4 (102)	4.38 (111)	4.63 (117)	5.75 (146)

^[1] Add 2.5 in. (64 mm) to H when using HF3 or HF4 floats.



Commercial Pressure and Float Switches for Power Circuits

Float Switches — Class 9036, 9037, and 9038

Use the following table to select the appropriate rod kit when ordering Class 9038 Type DG10, DW10, or DR10 alternators.

Table 30: Class 9049 Rod Kits for Class 9038 Type DG10, DW10, and DR10 Alternators

Float Travel for Class 9038 Types DG10, DW10, and DR10 Alternators Minimum Water Level Change (V = 4.69 in. / 119 mm)						
Dimensions in. (mm)	9049ER1	9049ER2	9049ER3	9049ER5	9049ER7	9049ER12
R	1.75 (44)	2.5 (64)	3.25 (83)	5.25 (133)	7.25 (184)	12.25 (311)
H^[1]	7.5 (191)	8.25 (210)	9 (229)	11 (279)	13 (330)	18 (457)
A	Min.	0.5 (13)	1 (25)	1.5 (38)	2.5 (64)	6 (152)
	Max.	1.5 (38)	2 (51)	2.5 (64)	4 (102)	9.25 (235)
B	Min	8 (203)	8.75 (222)	9.5 (241)	11.5 (292)	18.5 (470)
C	Min.	7 (178)	7.75 (194)	8.25 (210)	10 (254)	15.5 (394)
	Max.	7 (178)	7.5 (191)	8.25 (210)	10 (254)	17 (432)
D^[2]	Min.	1.75 (44)	1.75 (44)	1.5 (38)	1 (25)	0.5 (13)
	Max.	0.5 (13)	0.25 (6)	0.0 (0)	1 (25)	2.75 (70)
F	Min.	8.75 (222)	10.5 (267)	11 (279)	12.75 (324)	19 (483)
	Max.	8.5 (216)	9 (229)	9.5 (241)	10.5 (267)	15.75 (400)
G	Min.	3.25 (83)	3.5 (89)	3.5 (89)	3.75 (95)	4.75 (121)
	Max.	4.75 (121)	5 (127)	5.25 (133)	6 (152)	8.5 (216)

^[1] Add 2.5 in. (64 mm) to H when using HF3 or HF4 floats.

^[2] D is negative when the top of the float is below the horizontal centerline.

Figure 24: Type DG Dimensions

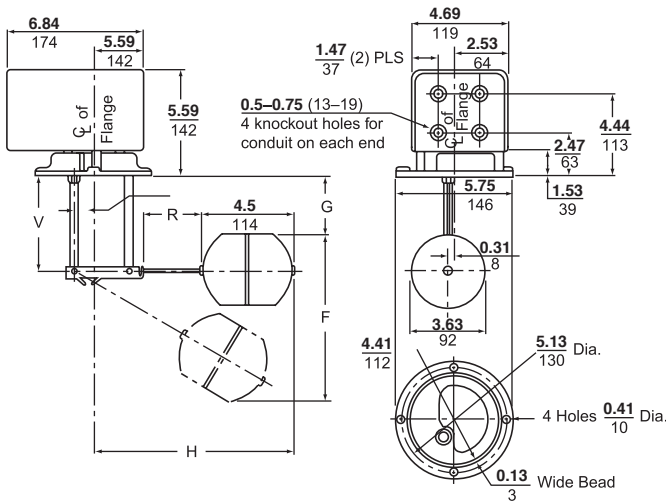
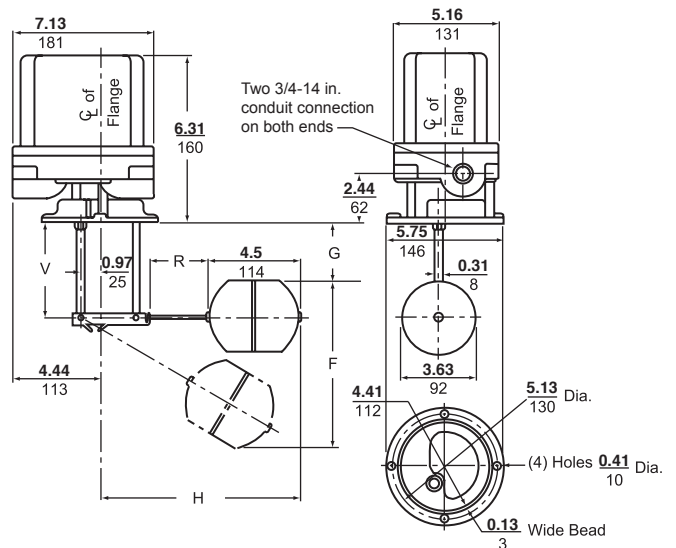

Figure 25: Type DR/DW Dimensions



Note: The recommended size of hole in the tank for the entry of the float and mounting of the control is 4.19 (106). Floats shown are Type EF, 4.5 (114) long. Add 2.5 (64) to H if using Type HF Floats, which are 7.0 (178) long.

Commercial Pressure and Float Switches for Power Circuits

Float Switches — Class 9036, 9037, and 9038

Class 9049 Accessories and Class 9998 Renewal Parts Kits

Table 31: Class 9049 Accessories

Catalog Number	Description	Equipment To Be Serviced
9049A6	7 in. Tapped at Top #304 Stainless Steel Float, 5 ft Brass Rod, 2 Stops	All 9036, 9038A
9049A6C	7 in. Center Hole #304 Stainless Steel Float, 5 ft Brass Rod, 4 Stops	All 9036, 9038A
9049A6CS	7 in. Center Hole #316 Stainless Steel Float, 5 ft Stainless Steel Rod, 4 Stainless Steel Stops	All 9036, 9038A
9049A6S	7 in. Tapped at Top #316 Stainless Steel Float, 5 ft Stainless Steel Rod, 2 Stainless Steel Stops	All 9036, 9038A
9049A13	Compensating Spring	9036GG
9049A54	Mounting Bracket—Replacing Obsolete 9036A with 9036G	9036GG
9049A55	Mounting Bracket—Replacing 9036A (S or F1) with 9036G	9036GG
9049A58	Form R Lever	9036DG
9049EF1	#304 Stainless Steel Float (do not remove ballast)	9037E, 9038D
9049EF2	#316 Stainless Steel Float (do not remove ballast)	9037E, 9038D
9049ER1	1-3/4 in. Stainless Steel Rod	9037E, 9038D
9049ER2	2-1/2 in. Stainless Steel Rod	9037E, 9038D
9049ER3	3-1/4 in. Stainless Steel Rod	9037E, 9038D
9049ER5	5-1/4 in. Stainless Steel Rod	9037E, 9038D
9049ER7	7-1/4 in. Stainless Steel Rod	9037E, 9038D
9049ER12	12-1/4 in. Stainless Steel Rod	9037E, 9038D
9049GF1	#304 Stainless Steel Float (do not remove ballast)	9037G
9049HF3	#304 Stainless Steel Float (do not remove ballast)	9037H, 9038C, D ⁽¹⁾
9049HF4	#316 Stainless Steel Float (do not remove ballast)	9037H, 9038C, D ⁽¹⁾
9049T1	Additional Rod Kit: One 2-1/2 ft Section of Brass Rod, Connector	9049A6, A6C
9049T1S	Additional Rod Kit: One 2-1/2 ft Section of Stainless Steel Rod, Connector	9049A6S, A6CS
9049UMS1	Universal Mounting Bracket	All 9036; 9038AG, AR, AW

⁽¹⁾ Not recommended for 9038D mechanical alternators. 9049EF1 (#304 SS) and 9049EF2 (#316 SS) are recommended instead.

Renewal parts are generally available for Pump Control products with a current date code or with a numerical date code (such as 172, which corresponds to the first quarter of 1972). Parts are no longer available for devices manufactured before 1965.

Commercial Pressure and Float Switches for Power Circuits

Float Switches — Class 9036, 9037, and 9038

Références, ordre alphabétique

9013FHG2 30	9013FHG39 31	9013FRG33 27	9013FSG29 24	9013GHG3 35
9013FHG3 30	9013FHG42 31	9013FRG58 28	9013FSG42 24	9013GHG5 36
9013FHG4 30, 32	9013FHG44 31	9013FRG62 29	9013FSG49 24	9013GHG6 37
9013FHG9 30	9013FHG49 31	9013FRG63 29	9013FSG52 24	9013GHR1 35
9013FHG12 30	9013FHG52 31	9013FRG72 29	9013FSW2 23	9013GHR2 35
9013FHG13 30	9013FHG54 31	9013FRG73 29	9013FSW29 24	9013GHR4 37
9013FHG14 31	9013FHG59 31	9013FRG89 29	9013FTG2 25	9013GHW2 36
9013FHG19 31	9013FRG2 27	9013FRG92 29	9013FTW2 25	9013GHW5 37
9013FHG22 30	9013FRG9 27	9013FRG93 29	9013FYG 4, 32	9013GMG2 33
9013FHG24 30	9013FRG12 27	9013FSG2 23	9013FYG2 26	9013GSB2 33
9013FHG29 30	9013FRG22 27	9013FSG9 23, 24	9013FYW2 26	9013GSG2 33
9013FHG32 30	9013FRG23 27	9013FSG10 23	9013GHB2 34	9013GSG3 33
9013FHG33 30	9013FRG29 28	9013FSG20 23	9013GHG1 35	9013GSR2 34
9013FHG34 31	9013FRG32 27	9013FSG22 24	9013GHG2 35	9013GSW2 34

9036DG2 44	9036DR31R 44	9036FG30 47	9036GR1 44	9036GW1R 44
9036DG2R 44	9036DW31 44	9036GG2 44	9036GW1 44	
9036DR31 44	9036DW31R 44	9036GG2R 44		

9037EG8 48	9037EW9 48	9037HG34 52	9037HW30 52	9037HW36 52
9037EG8R1F1 48	9037EW13 48	9037HG35 52	9037HW31 52	9037HW37 52
9037EG9 48	9037HG30 52	9037HG36 52	9037HW32 52	
9037EG10 48	9037HG31 52	9037HG37 52	9037HW33 52	
9037EG13 48	9037HG32 52	9037HG38 52	9037HW34 52	
9037ER9 48	9037HG33 52	9037HG39 52	9037HW35 52	

9038AG1 54, 55	9038CG31 56	9038CR31 56	9038CW33 56	9038DG9 58
9038AG1R 55	9038CG32 56	9038CR32 56	9038CW34 56	9038DG10 58
9038AR1 54, 55	9038CG33 56	9038CR34 56	9038CW35 56	9038DR8 58
9038AR1R 55	9038CG34 56	9038CR36 56	9038CW36 56	9038DW7 58
9038AW1 54, 55	9038CG35 56	9038CW31 56	9038DG7 58	9038DW8 58
9038AW1R 55	9038CG36 56	9038CW32 56	9038DG8 58	

9049A6 8, 45, 55, 62	9049A55 62	9049ER1 15, 48, 50, 51, 59, 60, 61, 62	9049ER5 15, 48, 50, 51, 59, 60, 61, 62	9049GF1 62
9049A6C 8, 45, 55, 62	9049A58 44, 62	9049ER2 15, 48, 50, 51, 59, 60, 61, 62	9049ER7 15, 48, 50, 51, 59, 60, 61, 62	9049HF3 15, 48, 58, 62
9049A6CS 8, 45, 55, 62	9049A60 9, 47	9049ER3 15, 48, 50, 51, 59, 60, 61, 62	9049ER12 15, 48, 50, 51, 59, 60, 61, 62	9049HF4 15, 48, 58, 62
9049A6S 8, 45, 55, 62	9049A61 9, 47			9049T1 8, 45, 55, 62
9049A13 44, 62	9049EF1 15, 48, 58, 62			9049T1S 8, 45, 55, 62
9049A54 62	9049EF2 15, 48, 58, 62			9049UMS1 9, 62



www.tesensors.com

The information provided in this catalogue contains description of products sold by TMSS France, its subsidiaries and other affiliated companies ("Offer") with technical specifications and technical characteristics of the performance of the corresponding Offer.

The content of this document is subject to revision at any time without notice due to continued progress in methodology, design and manufacturing.

To the extent permitted by applicable law, no responsibility or liability is assumed by TMSS France, its subsidiaries and other affiliated companies for any type of damage arising out of or in connexion with (a) informational content of this catalogue not conforming with or exceeding the technical specifications, or (b) any error contained in this catalogue, or (c) any use, decision, act or omission made or taken on the basis of or in reliance on any information contained or referred to in this catalogue.

NEITHER TMSS FRANCE, ITS SUBSIDIARIES, NOR ITS OTHER AFFILIATES, AS THE CASE MAYBE, MAKE NO WARRANTY OR REPRESENTATION OF ANY KIND, WHETHER EXPRESS OR IMPLIED, AS TO WHETHER THIS CATALOGUE OR ANY INFORMATION CONTAINED THEREIN SUCH AS PRODUCTS WILL MEET REQUIREMENTS, EXPECTATIONS OR PURPOSE OF ANY PERSON MAKING USE THEREOF.

Telemecanique™ Sensors is a trademark of Schneider Electric Industries SAS used under license by TMSS France. Any other brands or trademarks referred to in this catalogue are property of TMSS France or, as the case may be, of its subsidiaries or other affiliated companies. All other brands are trademarks of their respective owners. This catalogue and its content are protected under applicable copyright laws and provided for informative use only.

No part of this catalogue may be reproduced or transmitted in any form or by any means (electronic, mechanical, photocopying, recording, or otherwise), for any purpose, without the prior written permission of TMSS France. Copyright, intellectual, and all other proprietary rights in the content of this catalogue (including but not limited to audio, video, text, and photographs) rests with TMSS France, its subsidiaries, and other affiliated companies or its licensors. All rights in such content not expressly granted herein are reserved. No rights of any kind are licensed or assigned or shall otherwise pass to persons accessing this information.

As standards, specifications and design change from time to time, please ask for confirmation of the information given in this publication.

©2023, TMSS France, All Rights Reserved.

TMSS France
Head Office
35 rue Joseph Monier
F-92500 Rueil-Malmaison – France

TES ELECTRIC US, LLC
1875 Founders Dr.
Kettering, OH 45420 - United States of America
customer-support-NA@tesensors.com
(833)-737-1405

September 2023 - V1.1

TESEBRC000022EN