

RACK INSTALLATION

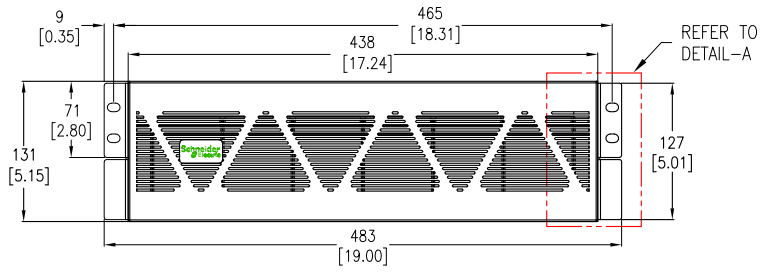

FRONT VIEW

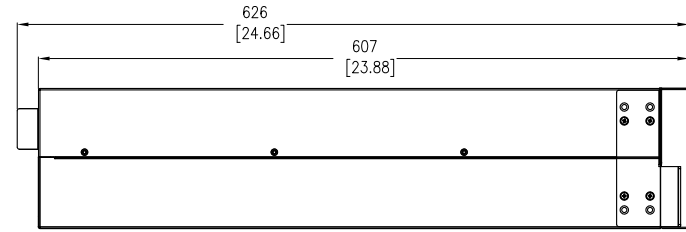

SIDE VIEW

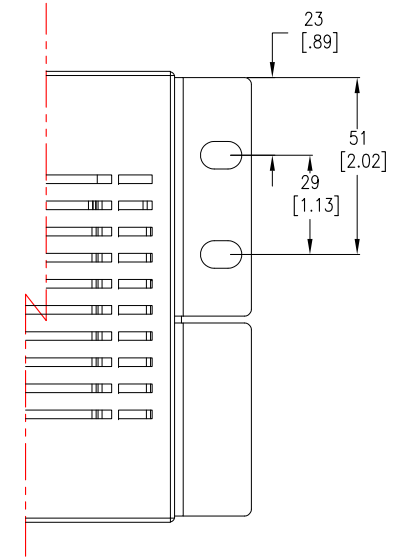

DETAIL-A (ENLARGED)

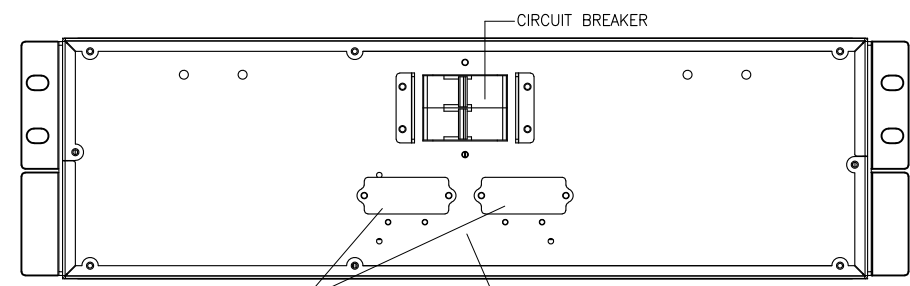

BATTERY CONNECTOR (COVER NOT SHOWN) GROUND SCREW

REAR VIEW (ENLARGED)

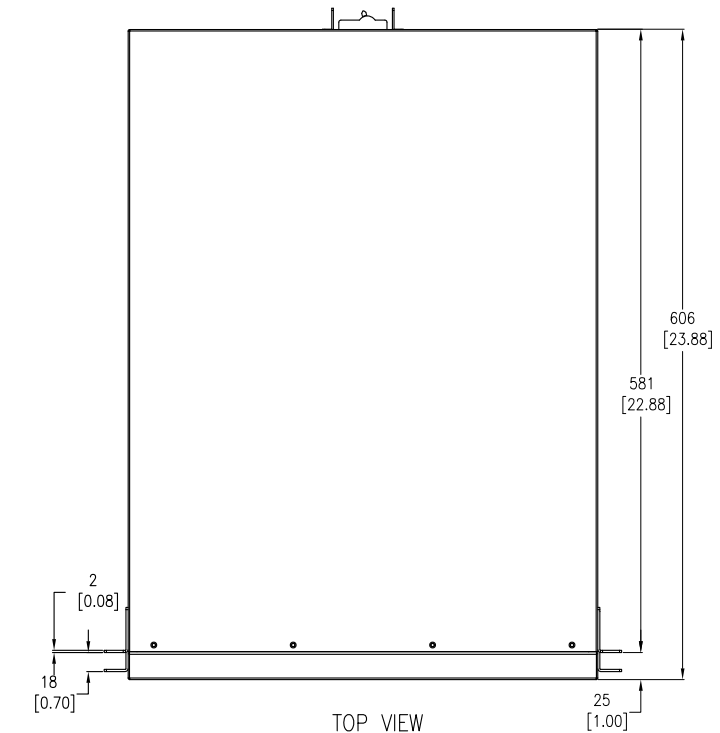

TOP VIEW

ISOMETRIC VIEW

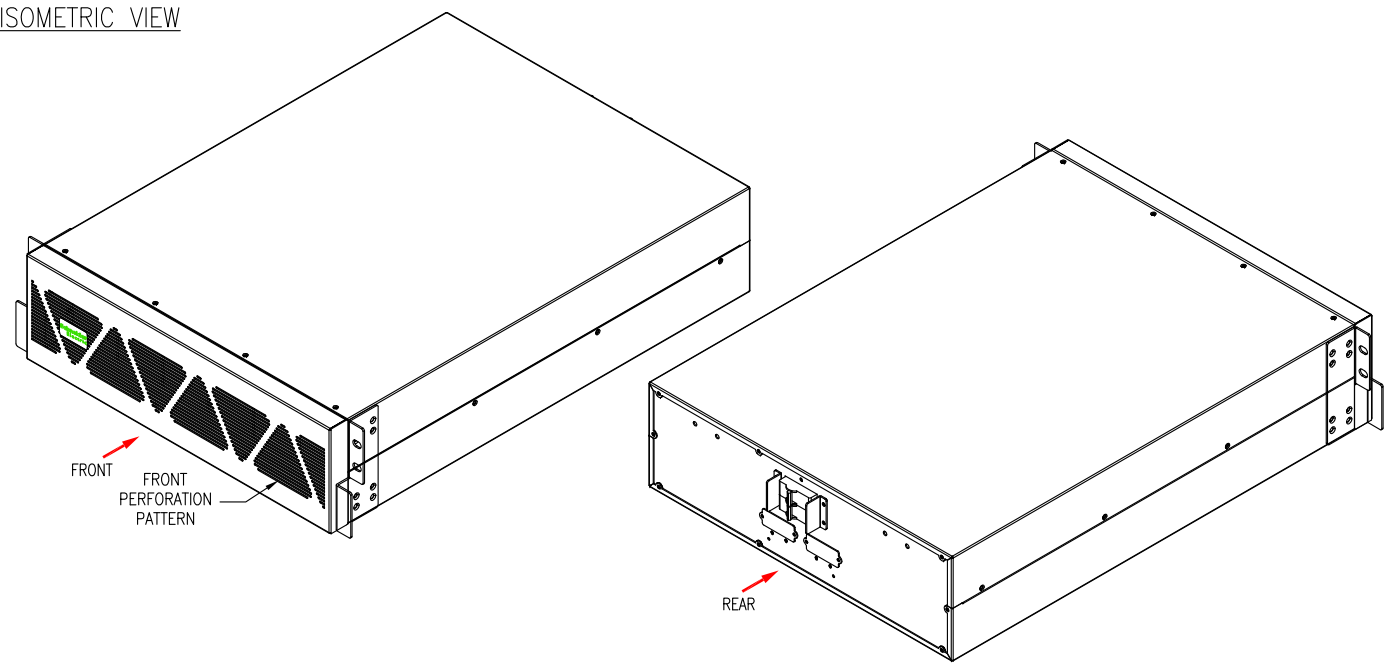

Battery Specification:	
Battery Type	Battery Bank Voltage
Sealed Maintenance Free (SMF): 1 string of 12V, 9Ah x 20	240 VDC

NOTES:

1. INSTALLATION SHALL COMPLY WITH ALL APPLICABLE NATIONAL AND LOCAL ELECTRICAL REGULATIONS.
2. REFER TO PRODUCT MANUALS FOR ADDITIONAL DETAILS PRIOR TO INSTALLATION AND SITE PREPARATION WORK.
3. ALL DIMENSIONS ARE IN MILLIMETERS [INCHES], UNLESS OTHERWISE SPECIFIED. DIMENSIONS EXCLUDE SCREWS AND PROTRUDING PARTS.
4. CABLE ENTRY IS FROM REAR SIDE OF UNIT.
5. NET WEIGHT OF THE UNIT 63.0kg [138.89 lb].
6. BATTERY CABLE IS PROVIDED WITH THE UNIT.

THIS DRAWING AND SPECIFICATIONS HEREIN ARE THE PROPERTY OF SCHNEIDER ELECTRIC AND SHALL NOT BE COPIED, REPRODUCED OR USED IN WHOLE OR IN PART, AS THE BASIS FOR THE MANUFACTURE OR SALE OF ITEMS WITHOUT WRITTEN PERMISSION FROM SCHNEIDER ELECTRIC. THIS DRAWING IS BASED UPON LATEST AVAILABLE INFORMATION AND IS SUBJECT TO CHANGE WITHOUT NOTICE.



TITLE: SE Easy UPS ON-LINE
SRVS RACKMOUNT BATTERY PACK FOR 5/6/10 kVA
EXTENDED RUNTIME MODEL 240V
GENERAL ARRANGEMENT

PROJECT: SUBMITTAL DRAWING SHEET 1 OF 1

DWG NO: SRVS240RLBP-9A REV. 0

DRAWN:	ASHISH	17-MAR-23	FIRST ANGLE PROJECTION
ENGINEER:	M LIPARE	17-MAR-23	
APPROVED:	PRITHIVIRAJ	17-MAR-23	