

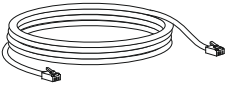
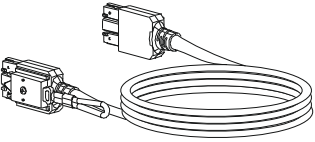
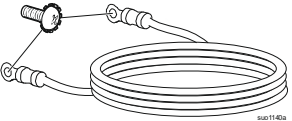
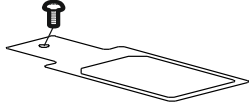

APC™ Smart-UPS™ Ultra Battery Pack Extension Cable SRTL016

Package Contents

| | | | |
|-------------------------------------------------------------------------------------------------------------------------------|---------------------------------------------------------------------------------------------------------------------------|-----------------------------------------------------------------------------------------------------------------------------------------------------------------|-----------------------------------------------------------------------------------------------------------------------------------------------------------------------|
| <p>A Communication cable (15 ft)</p>  | <p>B Extension cable (15 ft)</p>  | <p>C Ground wire (15 ft) with 2 nos. screws for securing the wire</p>  | <p>D Interconnection bracket with 1 no. screw for securing the bracket</p>  |
|-------------------------------------------------------------------------------------------------------------------------------|---------------------------------------------------------------------------------------------------------------------------|-----------------------------------------------------------------------------------------------------------------------------------------------------------------|-----------------------------------------------------------------------------------------------------------------------------------------------------------------------|

Installation

 **CAUTION**

RISK OF ELECTRIC SHOCK

- Do not connect the XLBP extension cable to the UPS/XLBP till the interconnection bracket is installed.
- Remove the interconnection bracket only after disconnecting the connector from the UPS/XLBP.

Failure to follow these instructions can result in minor or moderate injury and equipment damage.

NOTE: UPS model SRTL5KRM2Ux is used for purpose of illustration. The installation steps remain the same for SRTL8KRM4Ux and SRTL10KRM4Ux.

Single XLBP

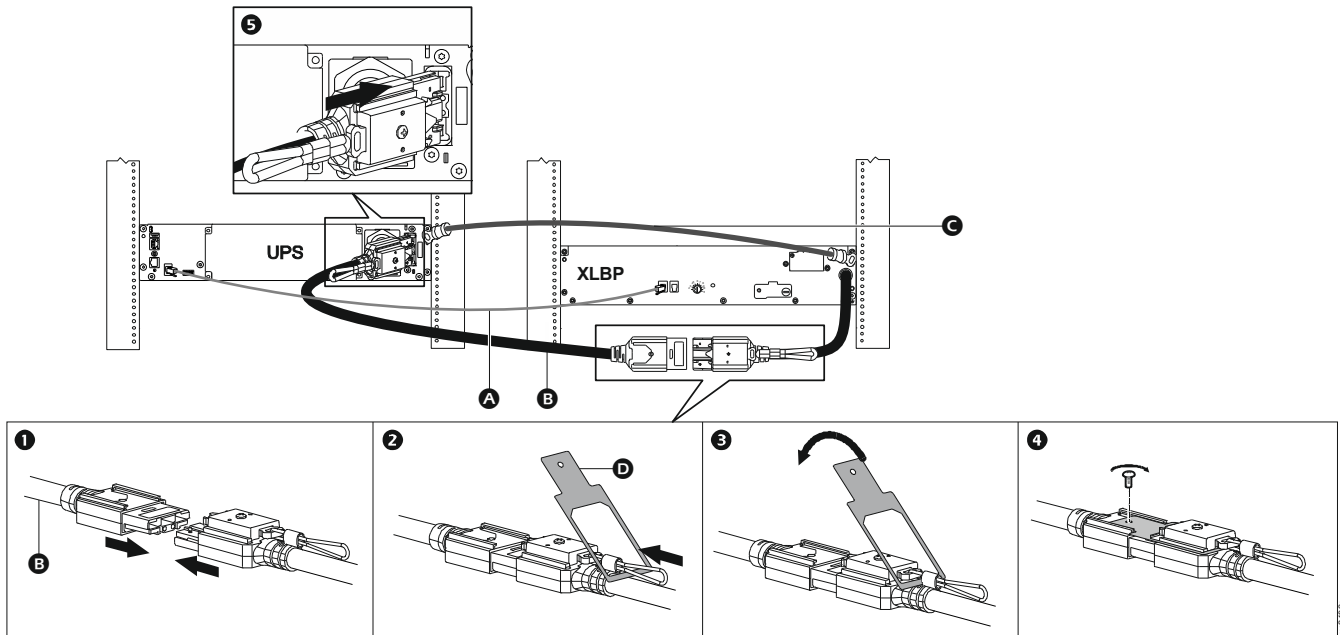

Multiple XLBPs

