



by Schneider Electric

Installation Guide Smart-UPS™ RT Replacement Battery Module APCRBC170/APCRBC171

Important Safety Instructions

Read the instructions carefully and look at the equipment to become familiar with the device before trying to install, operate, service or maintain it. The following special messages may appear throughout this document or on the equipment to warn of potential hazards or to call attention to information that clarifies or simplifies a procedure.



The addition of this symbol to either a “Danger” or “Warning” safety label indicates that an electrical hazard exists which will result in personal injury if the instructions are not followed.



This is the safety alert symbol. It is used to alert you to potential personal injury hazards. Obey all safety messages that follow this symbol to avoid possible injury or death.

DANGER

DANGER indicates a hazardous situation which, if not avoided, **will result in death** or serious injury.

WARNING

WARNING indicates a hazardous situation which, if not avoided, **could result in death** or serious injury.

CAUTION

CAUTION indicates a hazardous situation which, if not avoided, **could result in minor or moderate injury**.

NOTICE

NOTICE is used to address practices not related to physical injury.

Product Handling Guidelines



<18 kg
<40 lb



18-32 kg
40-70 lb



32-55 kg
70-120 lb



>55 kg
>120 lb



Safety and General Information

- Adhere to all local and national electrical codes.
- Always recycle used batteries.
- For information on recycling used battery modules, refer to the Battery Disposal Information sheet included with the replacement battery module.
- Recycle the package materials or save them for reuse.
- Before replacing batteries, remove conductive jewelry such as chains, wrist watches, and rings. High energy through conductive materials could cause severe burns.
- Do not dispose of battery or batteries in a fire. The batteries may explode.
- Do not open or mutilate batteries. Released electrolyte is harmful to the skin and eyes, and may be toxic.
- Servicing of user replaceable batteries should to be performed or supervised by personnel knowledgeable about batteries and required precautions.
- A battery can present a risk of electric shock and burns by high short-circuit current.
- Failed batteries can reach temperatures that exceed the burn thresholds for touchable surfaces.

Battery safety

⚠ CAUTION

RISK OF HYDROGEN SULPHIDE GAS AND EXCESSIVE SMOKE

- Replace the battery at least every 5 years or at the end of its service life, whichever is earlier.
- Replace the battery immediately when the UPS indicates battery replacement is necessary.
- Replace batteries with the same number and type of batteries as originally installed in the equipment.
- Replace the battery immediately when the UPS indicates a battery over-temperature condition, or when there is evidence of electrolyte leakage. Power off the UPS, unplug it from the AC input, and disconnect the batteries. Do not operate the UPS until the batteries have been replaced.
- *Replace all battery modules (including the modules in External Battery Packs) which are older than one year, when installing additional battery packs or replacing the battery module(s).

Failure to follow these instructions can result in minor or moderate injury and equipment damage.

* Contact APC by Schneider Electric Worldwide Customer Support to determine the age of the installed battery modules.

Replace Battery Modules

⚠ CAUTION

RISK OF FALLING OBJECTS



- The equipment is heavy. Each APCRBC170 battery module weighs 16.5kg (36.4 lb). Each APCRBC171 battery module weighs 25.1 kg (55.3 lb).
- Always practice safe lifting techniques adequate for the weight of the equipment.
- Adhere to all local and national electrical codes.
- Use the battery module handle to slide the battery modules in or out of the UPS and external battery pack (XLBP).
- Do not use the handle to lift or carry the battery module.

Failure to follow these instructions can result in minor or moderate injury and equipment damage.

Note: The batteries will charge to 90% capacity in the first 4 hours of operation on utility power. Do not expect full runtime capability during this initial charge period.

UPS	XLBP	RBC	Rail Kit
SURT5KXLI-CH SURT6KXLI-CH	SURT192XLBPG	APCRBC170	SURTRKG1
SURT8KXLI-CH SURT10KXLI-CH	SURT192XLBPG1	APCRBC171	
SRTG5KXLI SRTG5KXLT SRTG6KXLI		APCRBC170	SRTGRK1

Package Contents

<p>Installation manual</p>  <p>(x1)</p>	<p>Packing list</p>  <p>(x1)</p>
--	---

SURT192XLBPG models

1

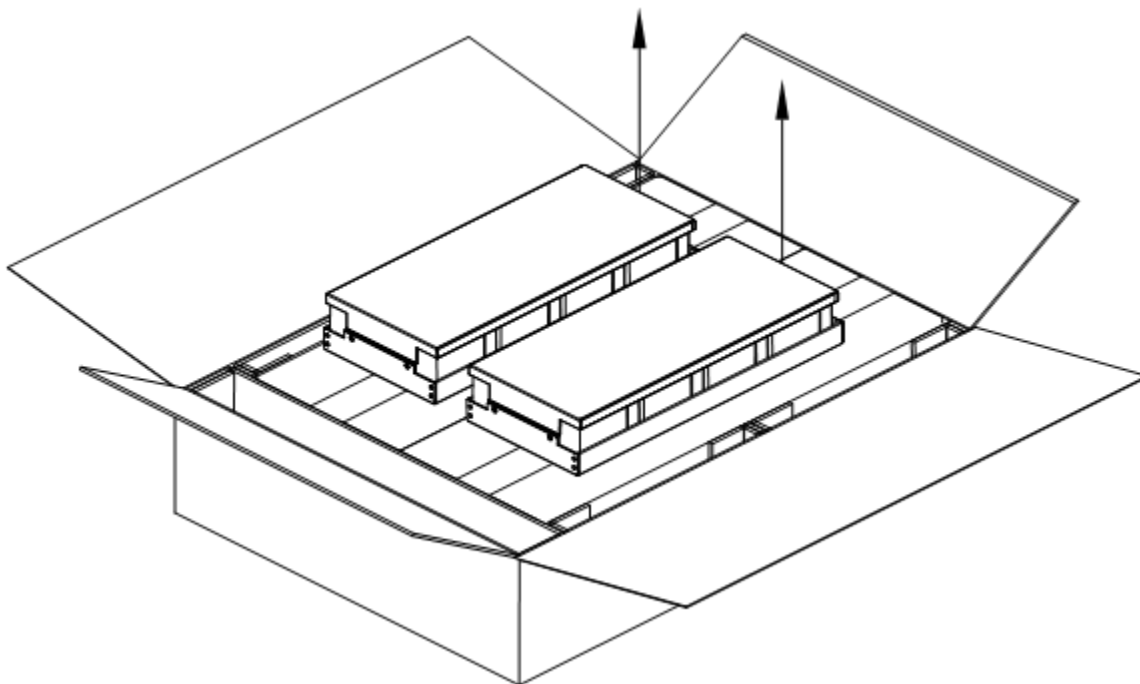

2

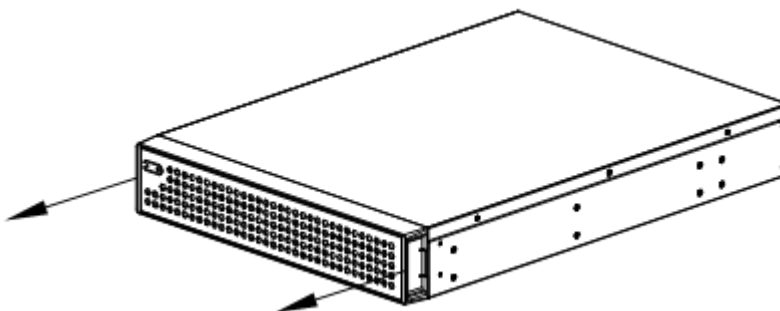

3

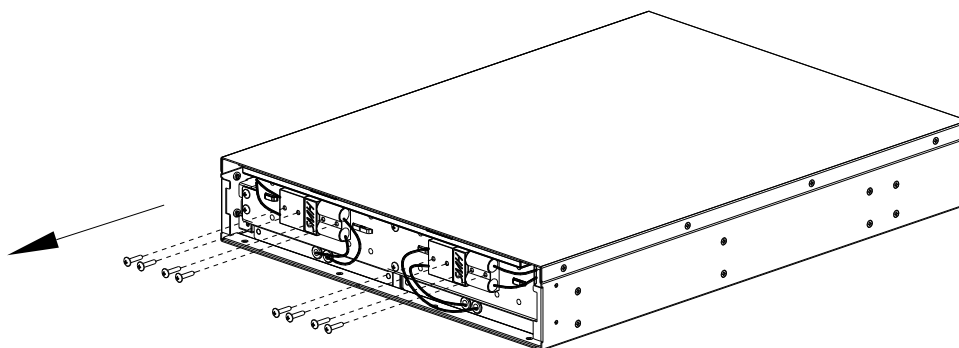

4

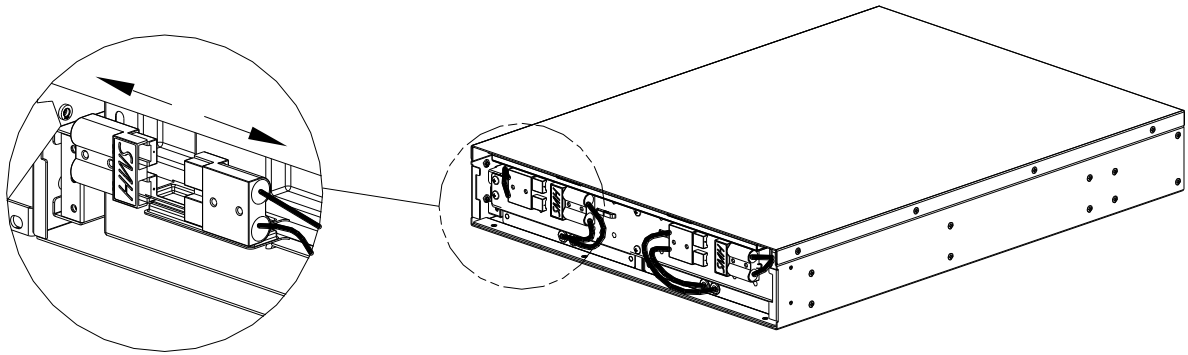

5

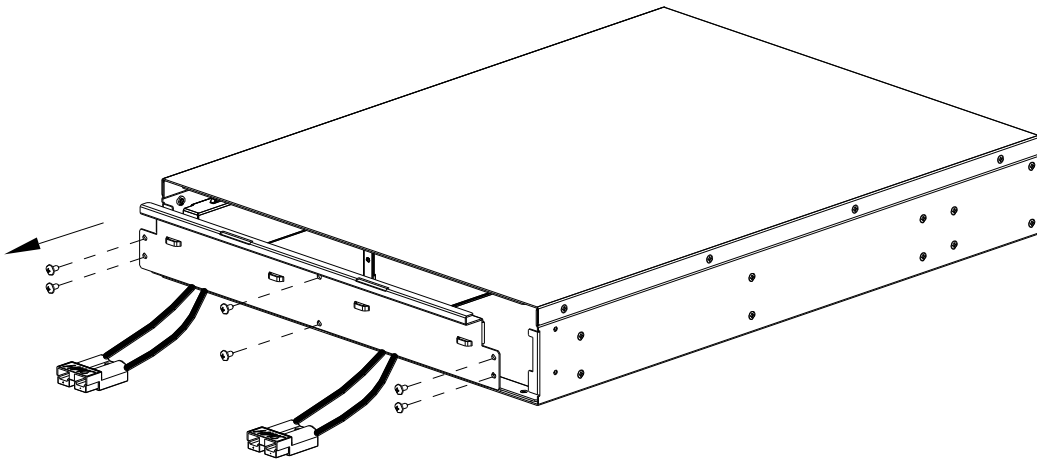

6

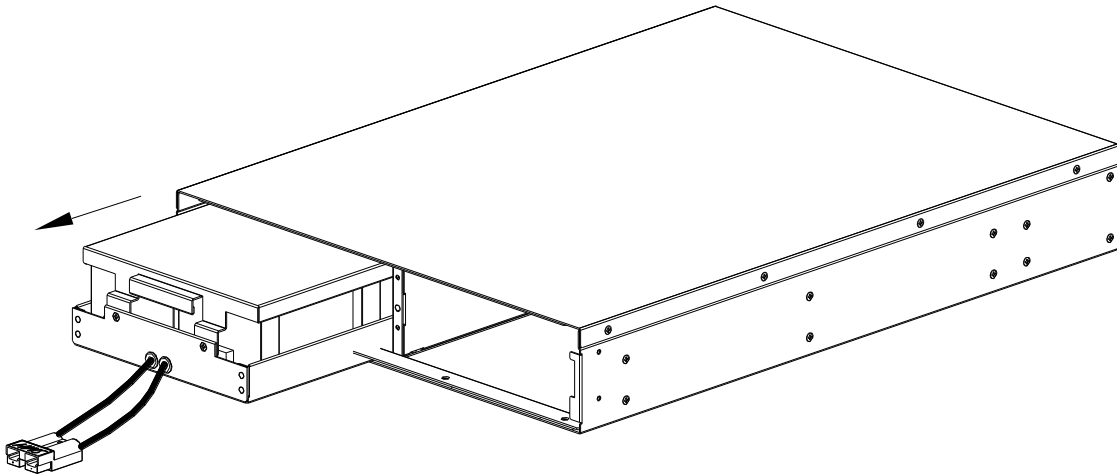

7

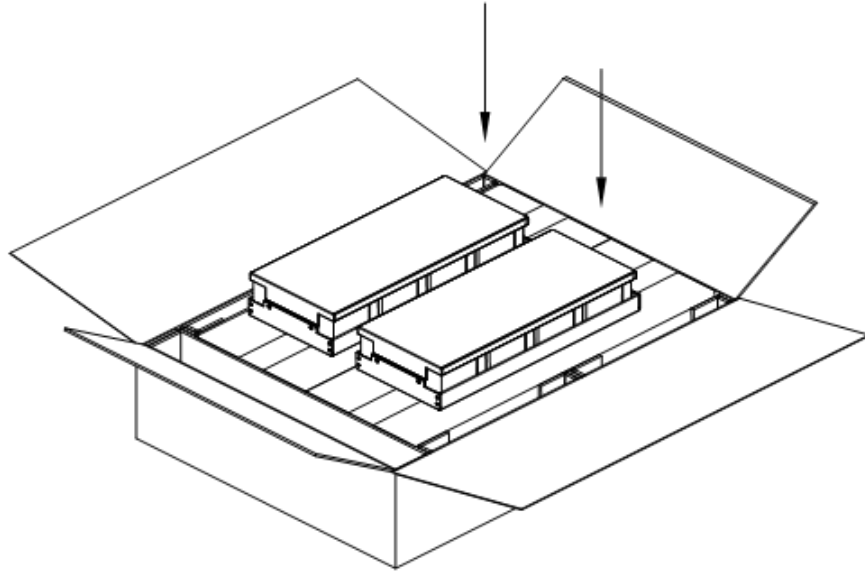

8

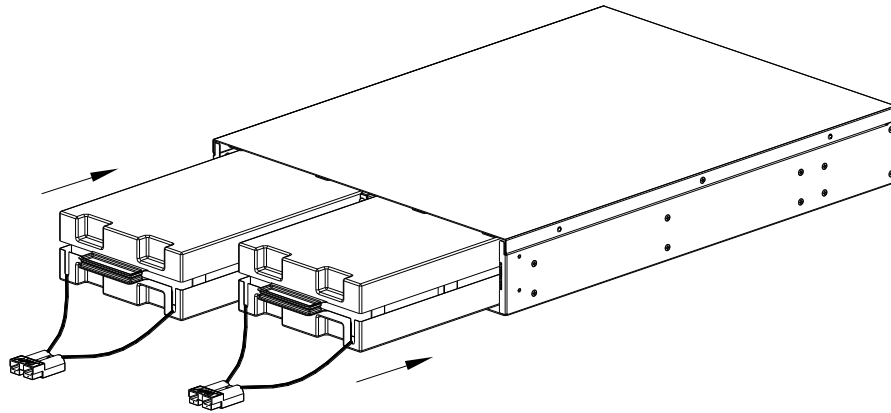

9

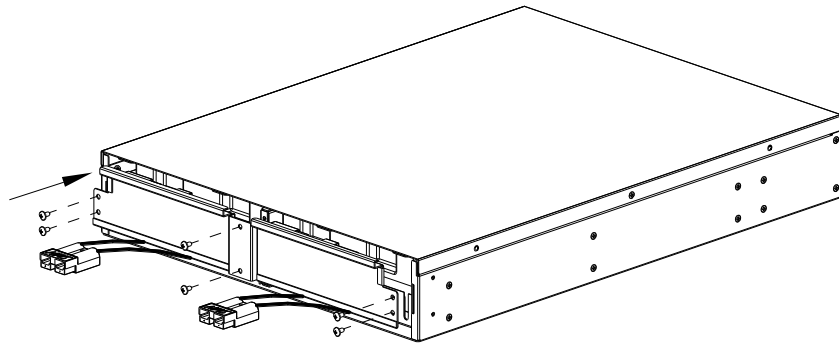

10

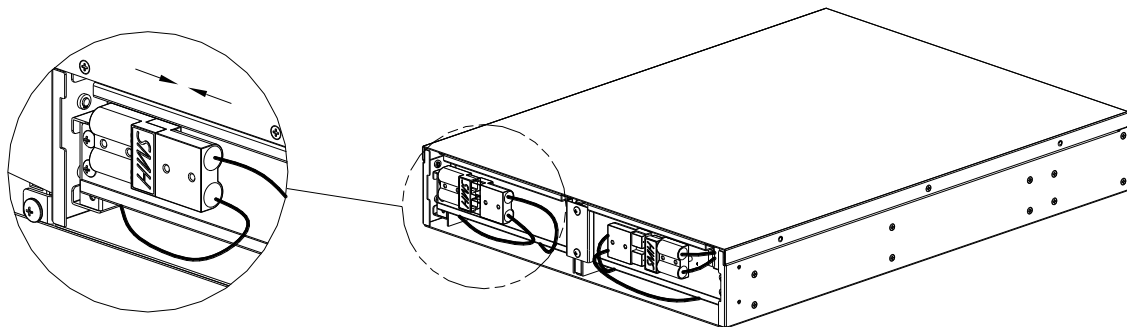

11

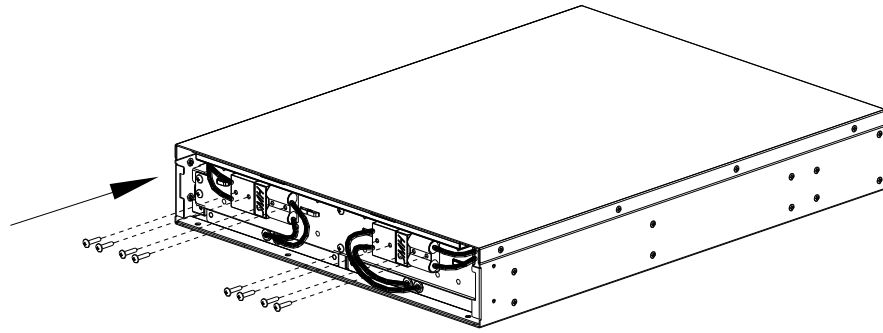

12

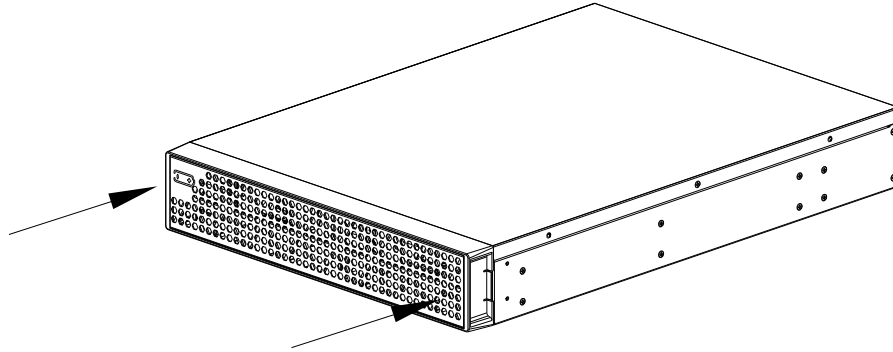

SURT5K / SURT6K / SRTG5K / SRTG6K XLI and SRTG5KXLT models

1

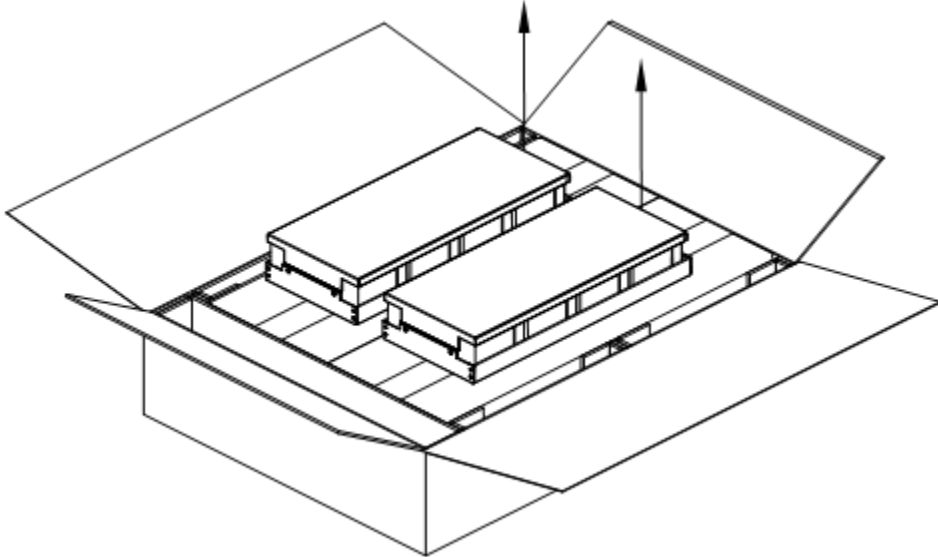

2

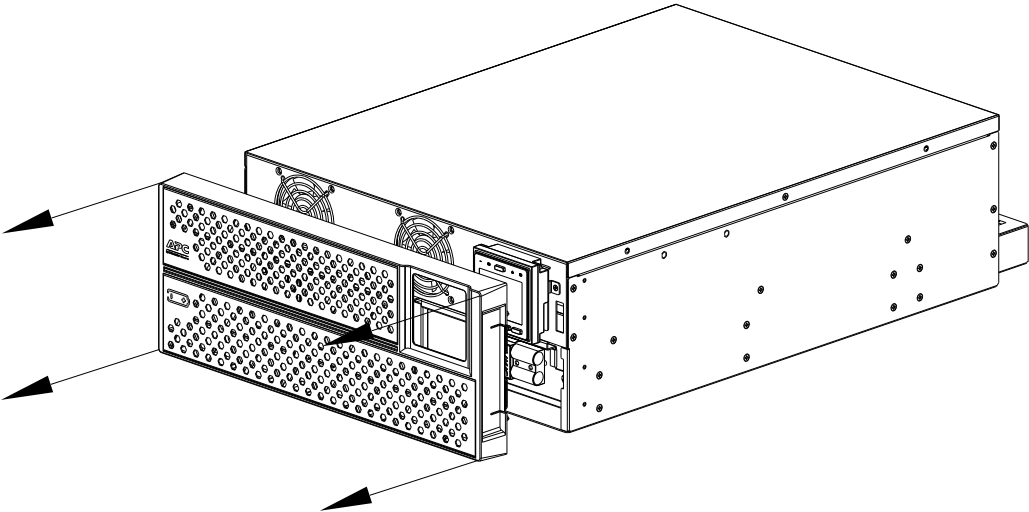

3

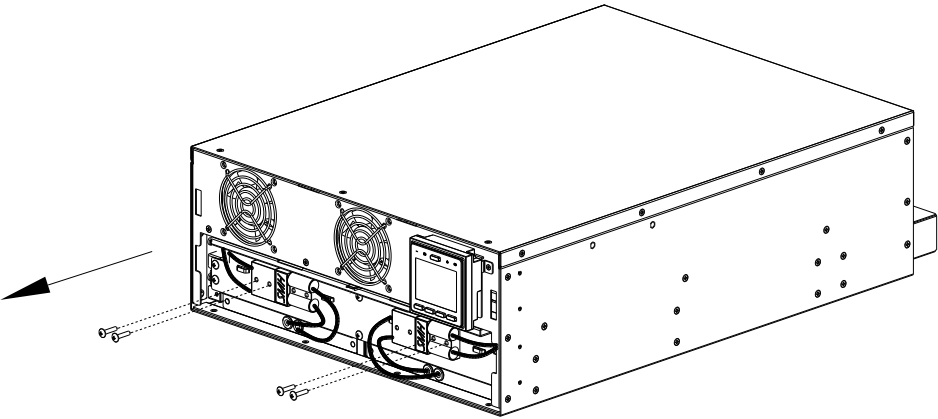

4

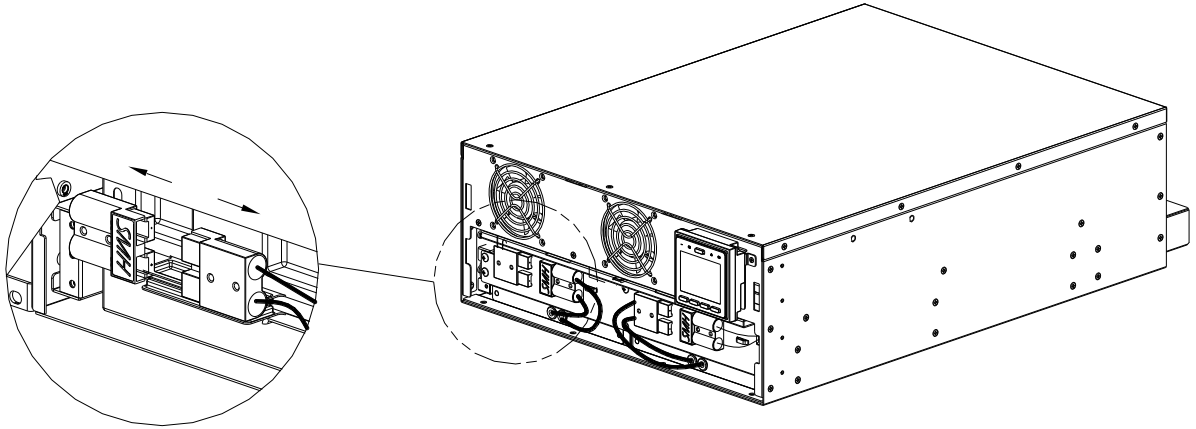

5

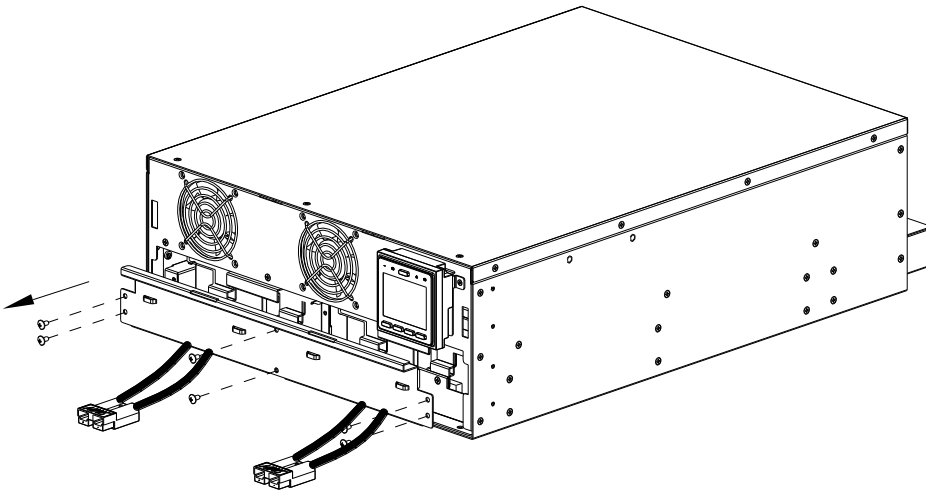

6

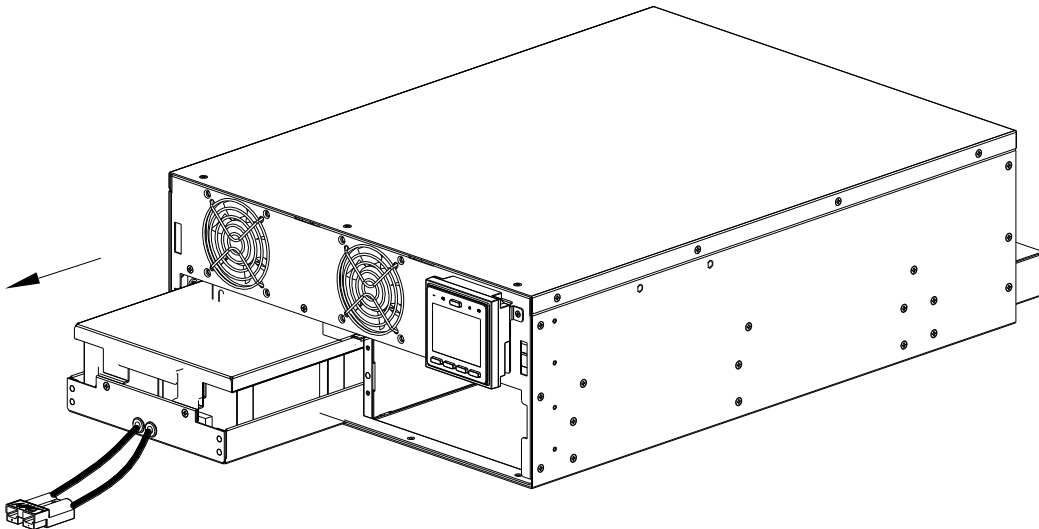

7

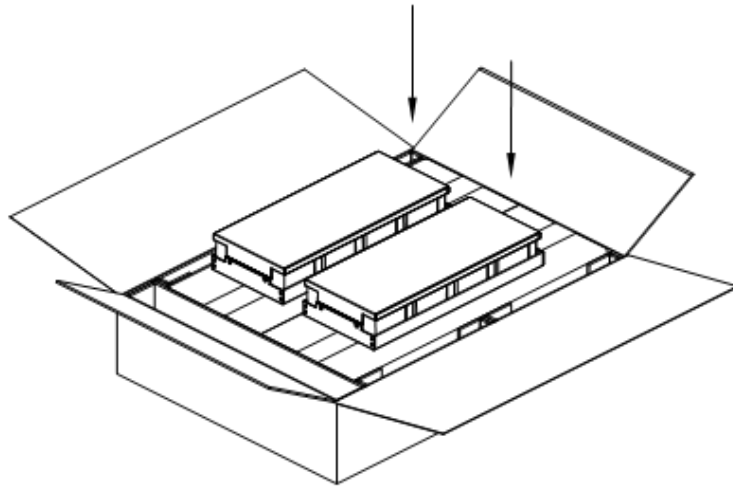

8

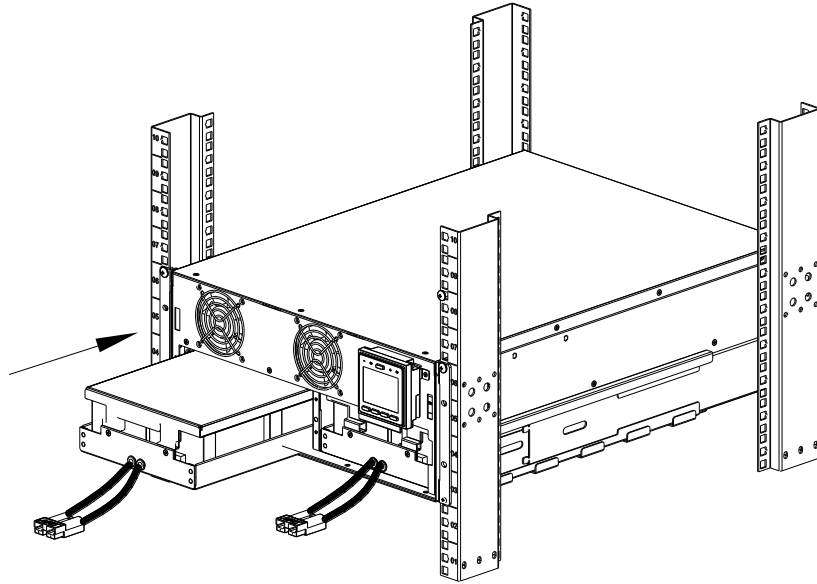

9

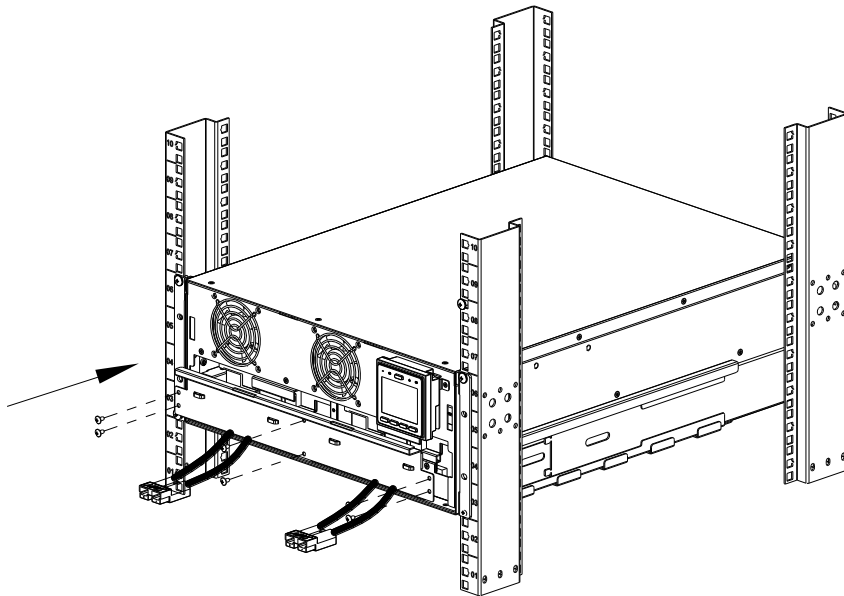

10

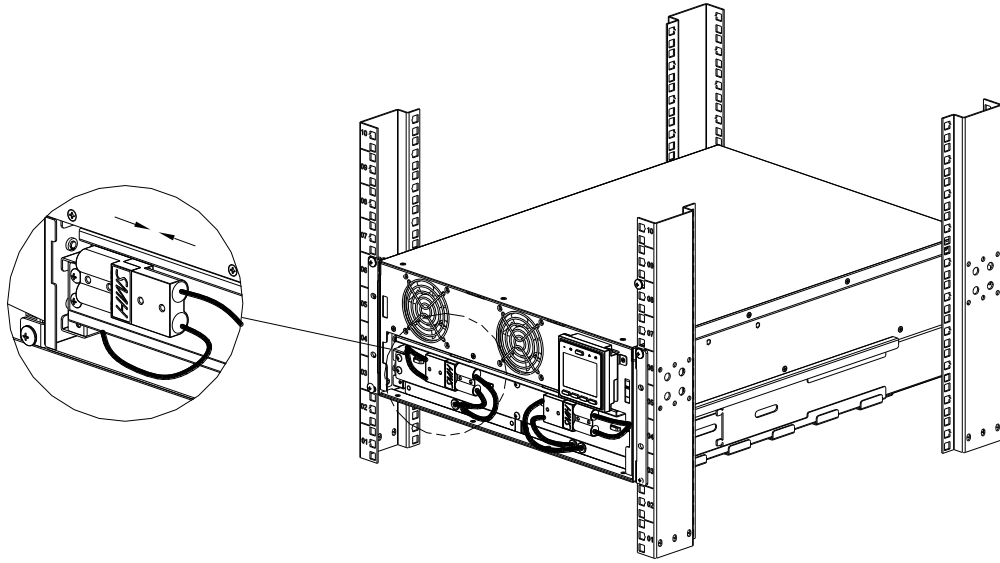

11

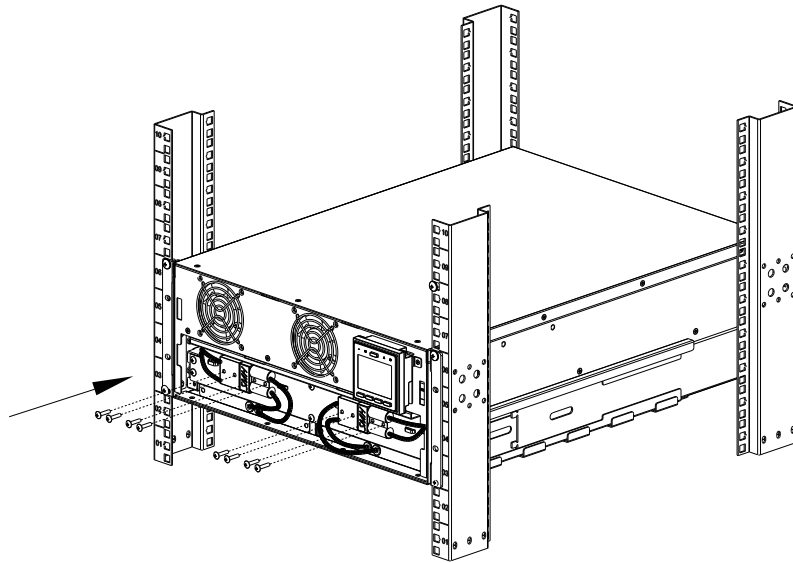

12

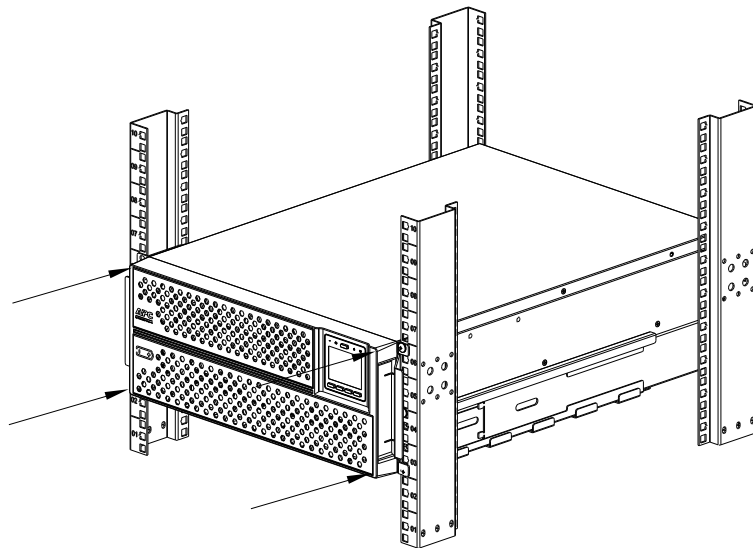

SURT192XLBPG1 models

1

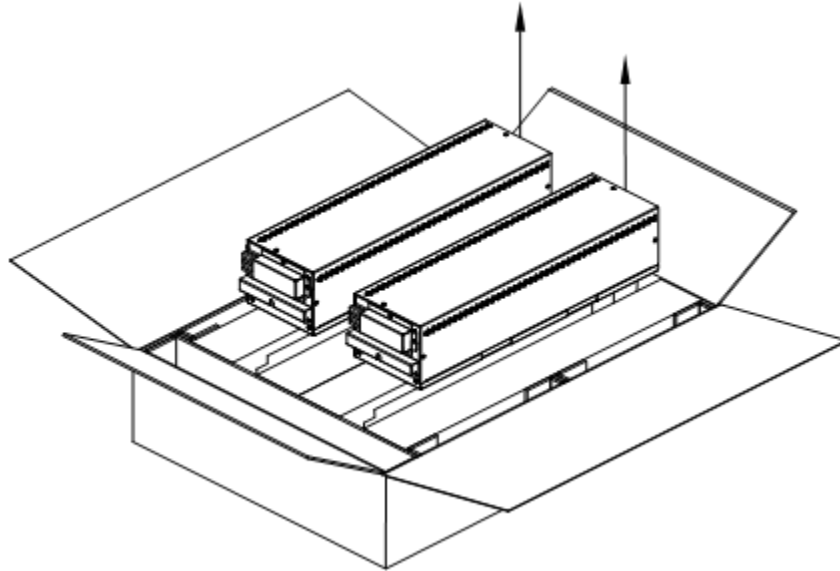

2

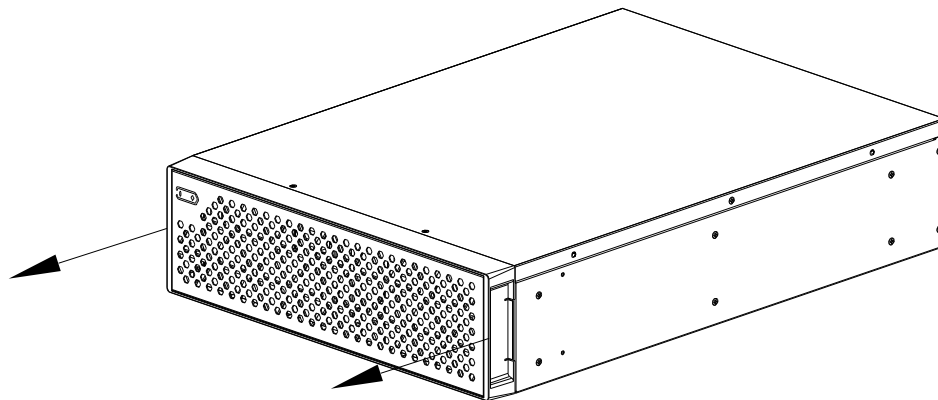

3

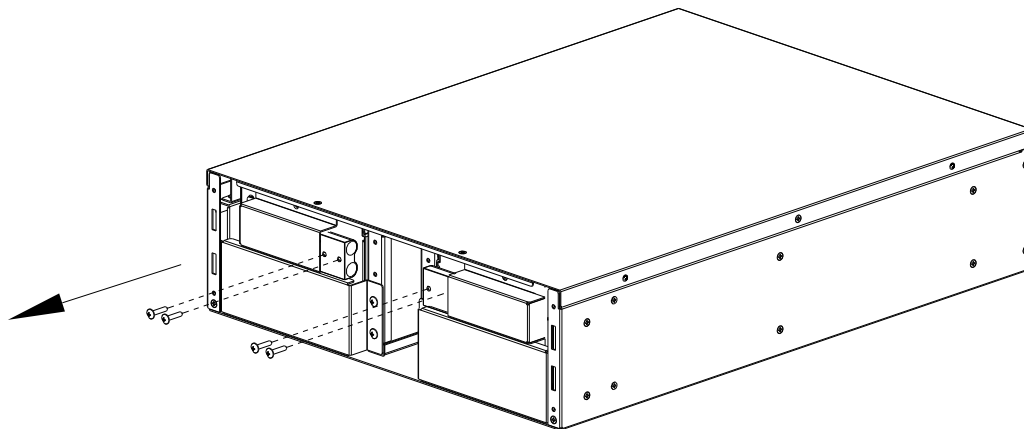

4

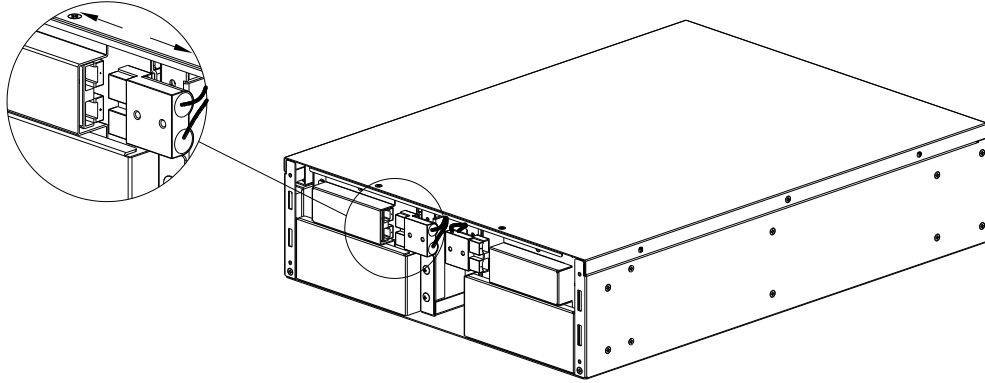

5

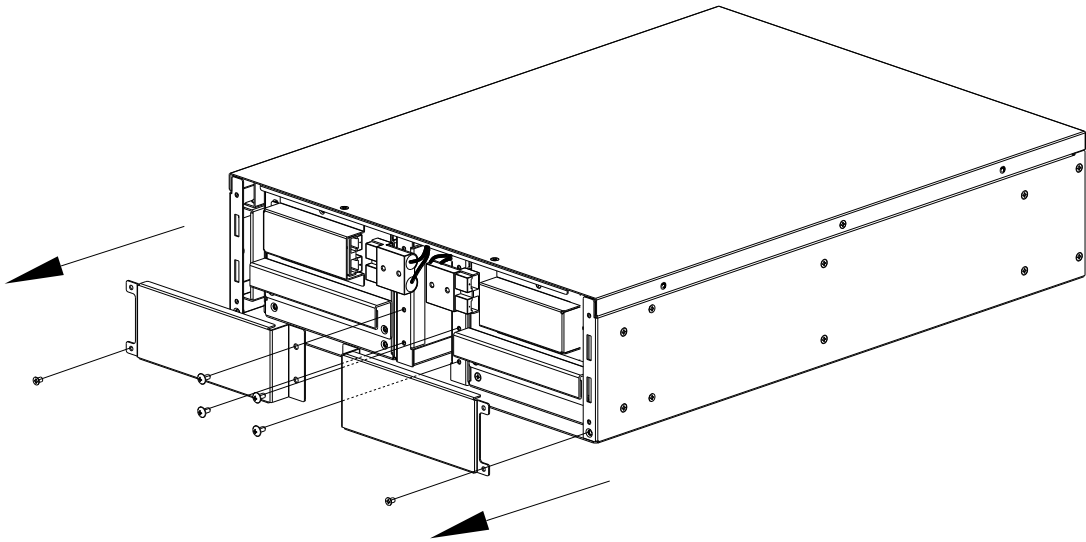

6

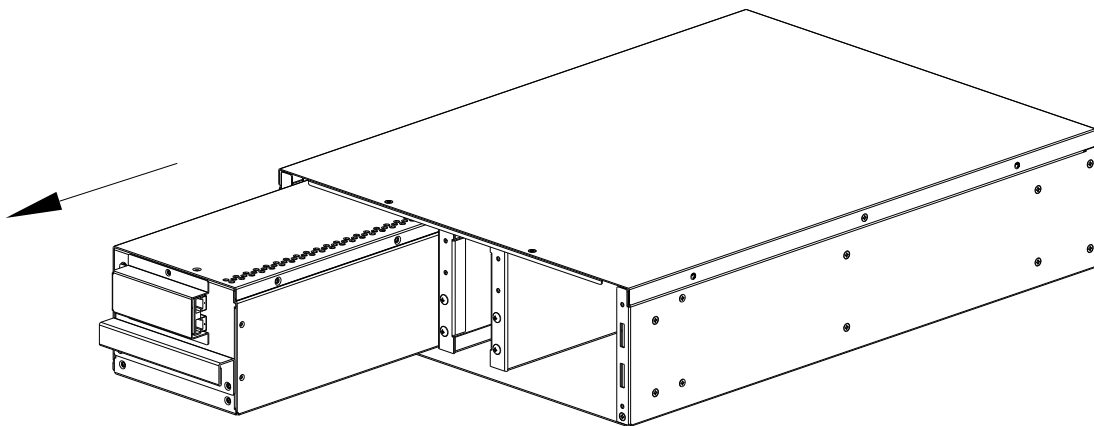

7

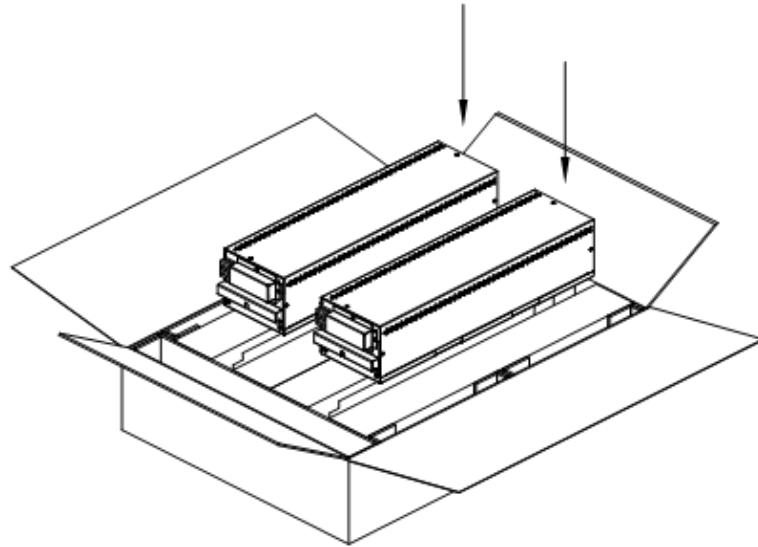

8

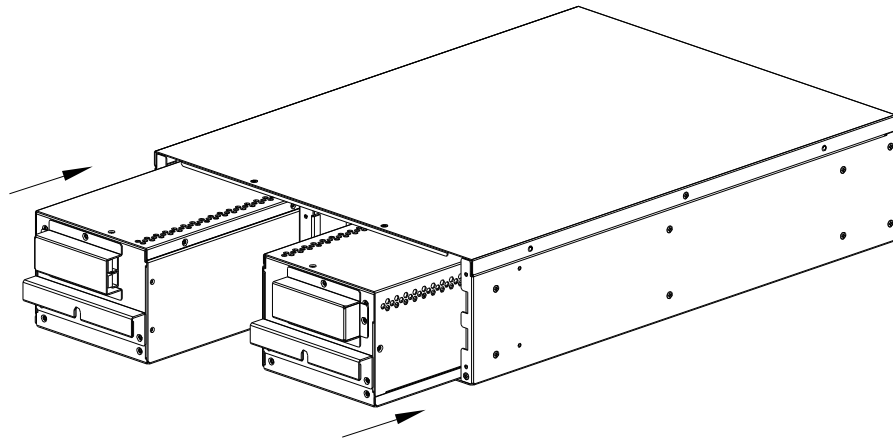

9

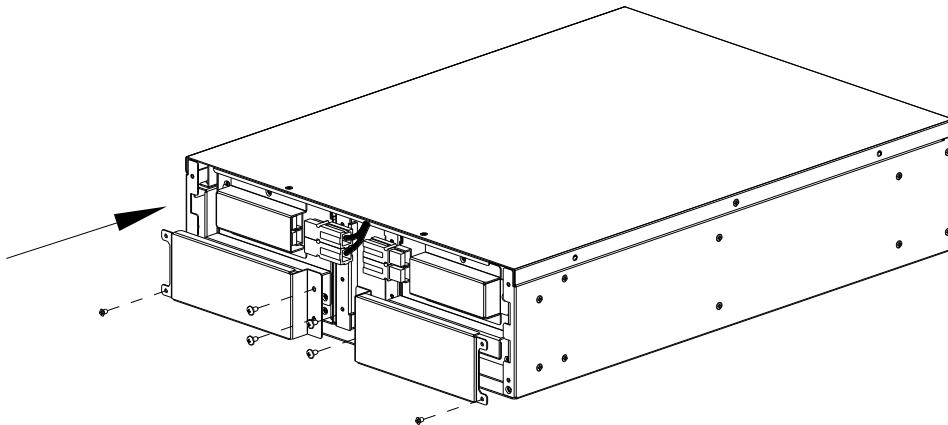

10

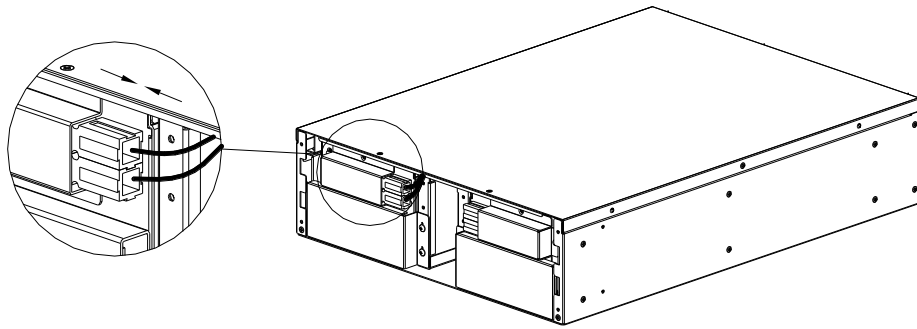

11

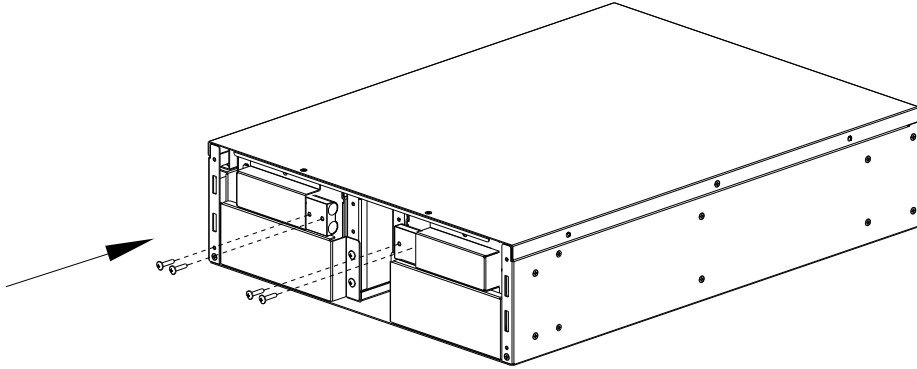

12

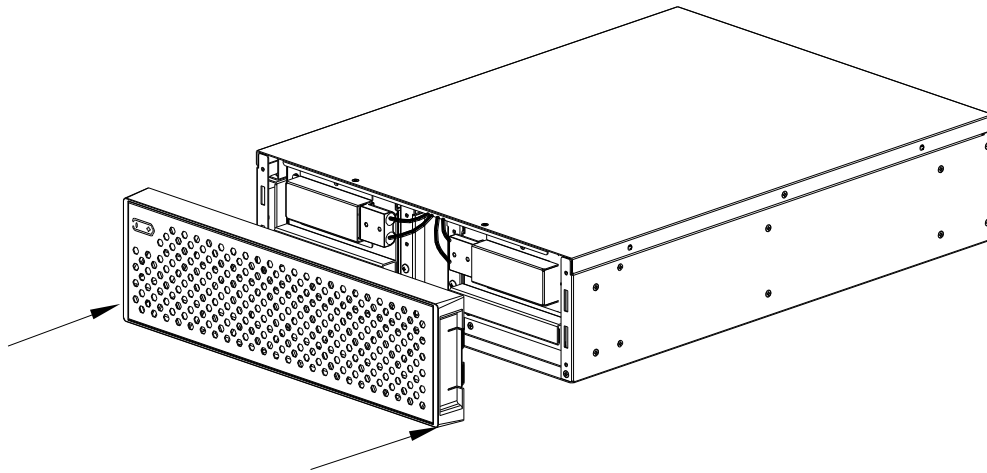

Check/modify the RBC installation date

Use the UP/DOWN arrow buttons to navigate to the Config Menu > Battery > Installation Date.

APC by Schneider Electric Worldwide Customer Support

Customer support for this or any other APC™ by Schneider Electric product is available at no charge in any of the following ways:

- Visit the APC by Schneider Electric web site to access documents in the APC by Schneider Electric Knowledge Base and to submit customer support requests.
 - **www.apc.com** (Corporate Headquarters)
Connect to localized APC by Schneider Electric web sites for specific countries, each of which provides customer support information.
 - **www.apc.com/support/**
Global support searching APC by Schneider Electric Knowledge Base and using e-support.
- Contact APC by Schneider Electric Customer Support Center by telephone or e-mail.
 - Local, country specific centers: go to **www.apc.com/support/contact** for contact information.

For information on how to obtain local customer support, contact the APC by Schneider Electric representative or other distributor from whom you purchased your APC by Schneider Electric product.

Customer support and warranty information are available on the APC by Schneider Electric web site, **www.apc.com**.

© 2020 APC by Schneider Electric. APC, the APC logo, and Smart-UPS are owned by Schneider Electric Industries S.A.S., or their affiliated companies. All other trademarks are property of their respective owners.

EN 990-6206
09/2020