



by Schneider Electric

Installation Smart-UPS™ RT SRTG15K-SRTG20K Tower/Rack-Mount

Important Safety Instructions

SAVE THESE INSTRUCTIONS: This manual contains important instructions that should be followed during installation and maintenance of the Smart UPS and batteries. Read these instructions carefully and look at the equipment to become familiar with the device before trying to install, operate, service or maintain it. The following special messages may appear throughout this document or on the equipment to warn of potential hazards or to call attention to information that clarifies or simplifies a procedure.



The addition of this symbol to either a “Danger” or “Warning” safety label indicates that an electrical hazard exists which will result in personal injury if the instructions are not followed.



This is the safety alert symbol. It is used to alert you to potential personal injury hazards. Obey all safety messages that follow this symbol to avoid possible injury or death.

DANGER

DANGER indicates a hazardous situation which, if not avoided, **will result in death or serious injury**.

WARNING

WARNING indicates a hazardous situation which, if not avoided, **could result in death or serious injury**.

CAUTION

CAUTION indicates a hazardous situation which, if not avoided, **could result in minor or moderate injury**.

NOTICE

NOTICE is used to address practices not related to physical injury.

Product Handling Guidelines



<18 kg
<40 lb



18-32 kg
40-70 lb



32-55 kg
70-120 lb



>55 kg
>120 lb



Safety and General Information

Inspect the package contents upon receipt. Notify the carrier and dealer if there is any damage.

- Changes and modifications to this unit not expressly approved by APC by Schneider Electric could void the warranty.
- This unit is intended only for indoor use in a controlled environment.
- Do not operate this unit in direct sunlight, in contact with fluids, or where there is excessive dust or humidity.
- Be sure the air vents on this unit are not blocked. Allow adequate space for proper ventilation.
- For a UPS with a factory installed power cord, connect the UPS power cable directly to a wall outlet. Do not use surge protectors or extension cords.
- The battery typically lasts for two to five years. Environmental factors impact battery life. Elevated ambient temperatures, poor quality utility power, causing frequent short duration discharges will shorten battery life.
- Up to 4 external battery packs (XLBP) can be connected to the UPS in parallel. The number of external battery packs connected can be set using the LCD display.

Note: For each XLBP added, increased recharge time will be required.

- The equipment is heavy. Always practice safe lifting techniques adequate for the weight of the equipment.
- The batteries are heavy. Remove the batteries before installing the UPS and external battery packs (XLBPs), in a rack.
- Always install XLBPs at the bottom in rack-mount configurations. The UPS must be installed above the XLBPs.
- Always install peripheral equipment above the UPS in rack-mount configurations.
- Additional safety information can be found in the Safety Guide supplied with this unit.
- Battery breaker must be turned off when the UPS is not operating for a long time.

Deenergizing safety

The UPS contains separate battery pack and may present a shock hazard even when disconnected from the branch circuit (mains). The AC output connectors may be energized by remote or automatic control at any time.

Before installing or servicing the equipment check that the:

- Input wall circuit breaker is in the OFF position.
- Internal UPS batteries are removed.
- XLBP battery modules are disconnected.

Electrical safety

- For models with a hardwired input, the connection to the branch circuit (mains) must be performed by a qualified electrician.
- 230 V models only: In order to maintain compliance with the EMC directive for products sold in Europe, output cords attached to the UPS must not exceed 10 meters in length.
- The protective earth conductor for the UPS carries the leakage current from the load devices (computer equipment). An insulated ground conductor is to be installed as part of the branch circuit that supplies the input power to the UPS. The conductor must have the same size and insulation material as the grounded and ungrounded branch circuit supply conductors. The conductor will typically be green and with or without a yellow stripe.
- The UPS input ground conductor must be properly bonded to protective earth at the service panel.
- If the UPS input power is supplied by a separately derived system, the ground conductor must be properly bonded at the supply transformer or motor generator set.

Battery safety

⚠ CAUTION

RISK OF FALLING OBJECTS

- The equipment is heavy. Each battery module weighs 24.5 kg (54 lb).
- Always practice safe lifting techniques adequate for the weight of the equipment.
- Remove the battery modules before installing the UPS.
- Use the battery module handle to slide the battery modules in or out of the UPS.
- Do not use the battery module handle to lift or carry the battery module.

Failure to follow these instructions can result in equipment damage and minor or moderate injury.

⚠ CAUTION

RISK OF HYDROGEN SULPHIDE GAS AND EXCESSIVE SMOKE

- Replace the battery at least every 5 years or at the end of its service life, whichever is earlier.
- Replace the battery immediately when the UPS indicates battery replacement is necessary. Replace batteries with the same number and type of batteries as originally installed in the equipment.
- Replace the battery immediately when the UPS indicates a battery over temperature condition, or when there is evidence of electrolyte leakage. Power off the UPS, unplug it from the AC input, and disconnect the batteries. Do not operate the UPS until the batteries have been replaced.
- *Replace all battery modules (including the modules in External Battery Packs) which are older than one year, when installing additional battery packs or replacing the battery module(s).

Failure to follow these instructions can result in minor or moderate injury and equipment damage.

* Contact APC by Schneider Electric Customer Support to determine the age of the installed battery modules.

- Before replacing batteries, remove conductive jewelry such as chains, wrist watches, and rings. High energy through conductive materials could cause severe burns.
- Do not lay tools or metal parts on top of batteries.
- Do not dispose of battery or batteries in a fire. The batteries may explode.
- Do not open or mutilate batteries. Released electrolyte is harmful to the skin and eyes, and may be toxic.
- Servicing of user replaceable batteries should to be performed or supervised by personnel knowledgeable about batteries and required precautions. Keep unauthorized personnel away from batteries.
- A battery can present a risk of electric shock and burns by high short-circuit current. The following precautions should be observed when working on batteries
 - a) Disconnect the charging source prior to connecting or disconnecting battery terminals.
 - b) Do not wear any metal objects including watches and rings.
 - c) Do not lay tools or metal parts on top of batteries.
 - d) Use tools with insulated handles.
 - e) Wear rubber gloves and boots.
 - f) Determine if battery is either intentionally or inadvertently grounded. Contact with any part of a grounded battery can result in electric shock and burns by high short-circuit current. The risk of such hazards can be reduced if grounds are removed during installation and maintenance by a skilled person.
- Failed batteries can reach temperatures that exceed the burn thresholds for touchable surfaces.

Hardwire safety

- Verify that all branch circuit (mains) and low voltage (control) circuits are deenergized, and locked out before installing cables or making connections, whether in the junction box or to the UPS.

- Wiring by a qualified electrician is required.
- Check national and local codes before wiring.
- Strain relief is required for all hardwiring (not supplied). Snap in type strain reliefs are recommended.
- All openings that allow access to UPS hardwire terminals must be covered. Failure to do so may result in personal injury or equipment damage.
- Select wire size and connectors according to national and local codes.

General information

- The model and serial numbers are located on a small, rear panel label.
- Always recycle used batteries.
- Recycle the package materials or save them for reuse.











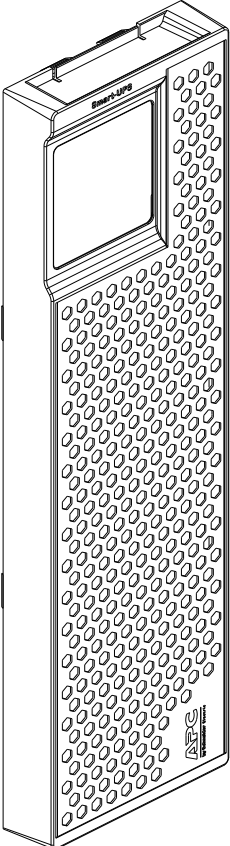
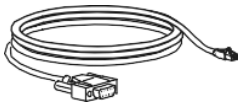

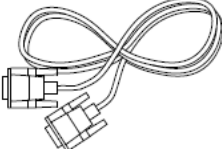
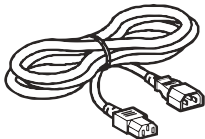
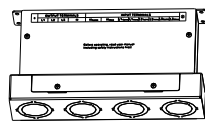

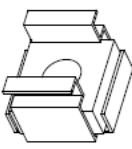
Radio frequency warning

This UPS is a category C3 product as per IEC 62040-2, meant for commercial and industrial application in the second environment installation restrictions or additional measures may be needed to prevent disturbances.

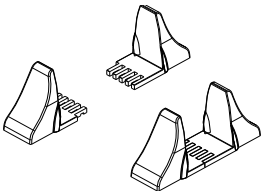
Package Contents

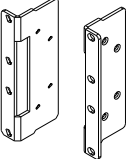
Inspect the contents upon receipt. Notify the carrier and dealer if the unit is damaged.

Included with all models:

<p>Front bezel</p>  <p>(x1)</p>	<p>RJ45 to DB9 cable</p>  <p>(x1)</p> <p>USB cable</p>  <p>(x1)</p> <p>Parallel cable</p>  <p>(x1)</p> <p>C19/C20, 16 A, 1.5 m</p>  <p>(x1)</p> <p>Terminal box</p>  <p>(x1)</p> <p>M4x8 screws to secure the terminal box to the UPS</p>  <p>(x4)</p>	<p>M5 Floating nut to secure the UPS to the pillar</p>  <p>(x4)</p> <p>M5x12 Phillips flat head screw to secure the UPS to the pillar</p>  <p>(x4)</p> <p>M4x6 flat head screws to secure the rack-mount brackets to the UPS</p>  <p>(x8)</p> <p>M4x8 screws to secure the jumper to the UPS</p>  <p>(x3)</p> <p>M6x12 screws to secure the jumper to the UPS</p>  <p>(x2)</p>	<p>Stabilizer bracket</p>  <p>(x2pairs)</p> <p>Stabilizer bracket connectors</p>  <p>(x2)</p> <p>Rack-mount brackets</p>  <p>(x1pair)</p> <p>Installation manual</p>  <p>(x1)</p> <p>Packing list</p>  <p>(x1)</p> <p>Factory routine test report</p>  <p>(x1)Factory routine test report</p>
---	---	--	--

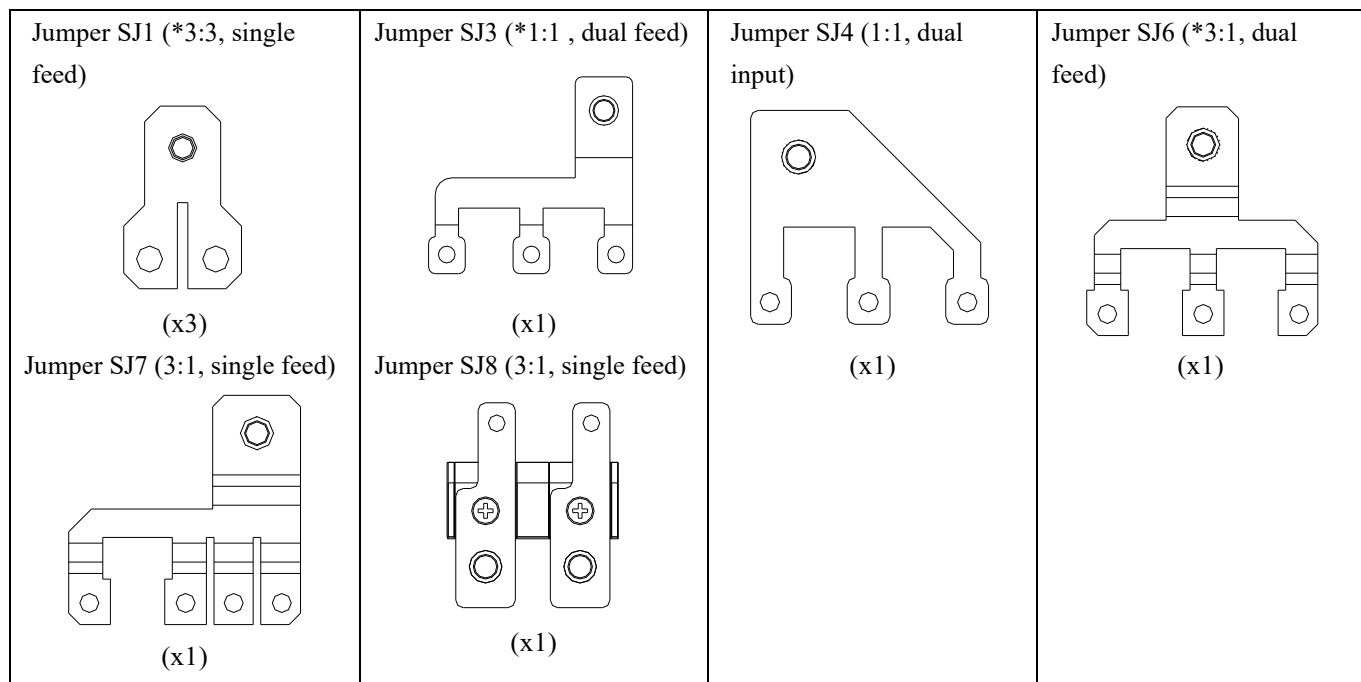





*1:1: 1 phase input / 1 phase output



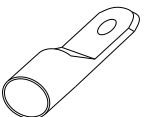

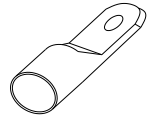

*3:1: 3 phase input / 1 phase output

*3:3: 3 phase input / 3 phase output

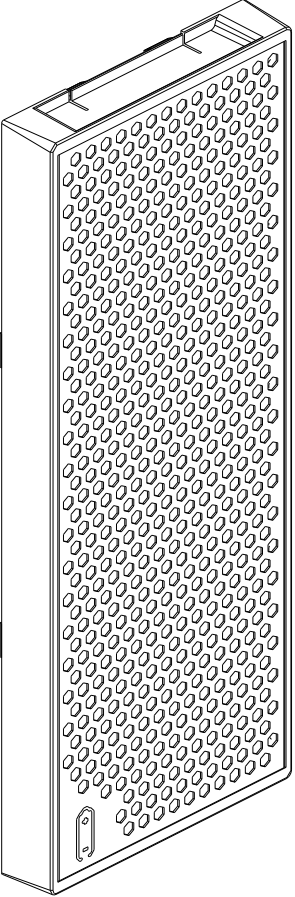
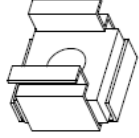
Hereinafter referred to as “1:1”, “3:1” and “3:3”.

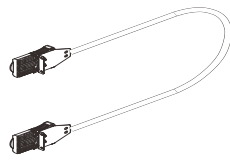
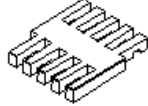
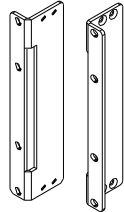

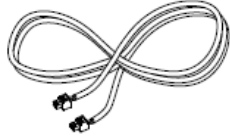
For SRTG15KXLI			
<p>Terminal</p>  <p>16 mm² - Φ6 mm - x3 25 mm² - Φ6 mm - x5</p>	<p>Heat shrink tube</p>  <p>Φ8x30 - x3 Φ10x30 - x5</p>		
For SRTG20KXLI			
<p>Terminal</p>  <p>25 mm² - Φ6 mm - x3 35 mm² - Φ6 mm - x5</p>	<p>Heat shrink tube</p>  <p>Φ10x30 - x3 Φ12x35 - x5</p>		

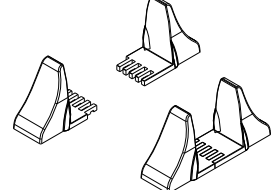
Included in the battery pack supplied with the UPS

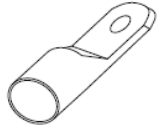

<p>Front bezel</p>  <p>(x1)</p>	<p>M5 Floating nut to secure the UPS to the pillar</p>  <p>(x4)</p> <p>M4x10 flat head screws to secure the rack-mount brackets to battery Pack.</p>  <p>(x8)</p> <p>M5x12 Phillips flat head screw to secure the UPS to the pillar</p>  <p>(x4)</p> <p>Battery cable 0.64m</p>  <p>(x1)</p>	<p>Stabilizer bracket connectors</p>  <p>(x8)</p> <p>Rack-mount brackets</p>  <p>(x1 pair)</p> <p>Ground wire 0.64m</p>  <p>(x1)</p> <p>Battery pack temperature sensor wire 0.64m</p>  <p>(x1)</p>	<p>Installation manual</p>  <p>(x1)</p> <p>Packing list</p>  <p>(x1)</p> <p>Stabilizer bracket</p>  <p>(x2 pairs)</p>
---	--	---	--

Recommended terminals and heat shrink tubings (not supplied)

For SRTG15KXLI

Terminal 	3:1	10 mm ² - Φ6 mm - x4
		16 mm ² - Φ6 mm - x3
		25 mm ² - Φ6 mm - x5
	3:3	6 mm ² - Φ6 mm - x5
		10 mm ² - Φ6 mm - x9
Heat shrink tube 	3:1	Φ8x30 - x7
		Φ10x30 - x5
	3:3	Φ6x30 - x5
		Φ8x30 - x9

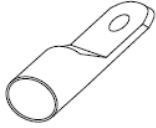
For SRTG20KXLI

Terminal 	3:1	16 mm ² - Φ6 mm - x4
		25 mm ² - Φ6 mm - x3
		35 mm ² - Φ6 mm - x5
	3:3	10 mm ² - Φ6 mm - x5
		16 mm ² - Φ6 mm - x9
Heat shrink tube 	3:1	Φ8x30 - x4
		Φ10x30 - x3
		Φ12x35 - x5
	3:3	Φ8x30 - x14

Specifications

For additional specifications refer to the APC by Schneider Electric Web site, www.apc.com.

Environmental

Temperature	Operating	0 to 40 °C (32 to 104 °F)
	Storage	-15 to 45 °C (5 to 113 °F)
Maximum Elevation	Operating	0 - 3,000 m (0 - 10,000 ft) 0 - 1,000 m no derating; 1,000 to 3,000 m, power reduction of 1%/100 m
	Storage	0 to 15,000 m (0 to 50,000 ft)
Humidity		0% to 95% relative humidity, non-condensing
International Protection Code		IP20
Applicable Standard		IEC 62040-1
Pollution Degree		2
Overvoltage category		II
Applicable power grid power distribution system		IT/TT/TN
<p>Note: Charge the battery modules every six months during storage. Environmental factors impact battery life. Elevated ambient temperatures, high humidity, poor quality mains power, causing frequent short duration discharges will shorten battery life.</p>		

Physical

The UPS is heavy. Follow all lifting guidelines.

	SRTG15KXLI / SRTG20KXLI
Unit weight without packaging	142.5 kg
Unit weight with packaging	157.2 kg
Unit dimensions without packaging Height x Width x Depth	306 x 440 x 700 mm (12.0 x 17.3 x 27.6 in.) *D1=625 mm (24.60 in); *D2=835 mm (32.87 in)
Unit dimensions with packaging Height x Width x Depth	535 x 590 x 790 mm (21.1 x 23.2 x 31.1 in.)
Screw of grounding	M6*2
The model and serial numbers are on a small label located on the rear panel.	

*** Details of D1 and D2**

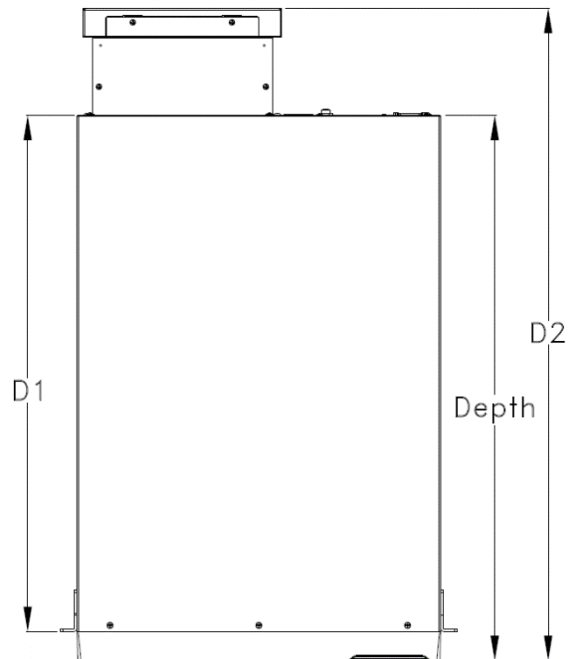

Battery

UPS model	SRTG15KXLI / SRTG20KXLI
XLBP model	SRTG192XLBP2
Replacement battery module This UPS has replaceable battery modules. Refer to the appropriate replacement battery user manual for installation instructions. Contact your dealer or go the APC by Schneider Electric Web site, www.apc.com. for information on replacement batteries.	APCRBC172
Total voltage of battery pack for the UPS Ah rating	±192 VDC 9 Ah
Battery type	Sealed Maintenance Free Valve Regulated Lead Acid
Max. number of battery pack	4 battery packs excluding the one supplied with UPS
XLBP cable length	0.64 m

UPS model	SRTG15KXLI / SRTG20KXLI
Number of batteries	1 - 5 (including the one supplied with UPS)
Ah rating	9 Ah
Charger current	1.8 - 5 A
Max. charger current*	5 A

* refers to $I_{\text{charge}} = 0.2 \times (\text{AH of each battery pack}) \times (\text{No of battery packs})$

UPS	XLBP	RBC	Parallel Kit	Rail Kit
SRTG15KXLI SRTG20KXLI	SRTG192XLBP2	APCRBC172	SRTGPK01	SRTGRK1 for UPS Power Module SRTGRK2 for Battery Pack

Electrical

Model	Rating
SRTG15KXLI	15 kVA / 15 kW
SRTG20KXLI	20 kVA / 20 kW

Output

Output Frequency	50/60 Hz \pm 4 Hz
Nominal Output Voltage	Phase to neutral : 220/230/240 VAC (1:1 & 3:1) Phase to phase : 380/400/415 VAC (3:3)
Output short-circuit RMS current	350A
Output short-circuit peak current	450A
Output short circuit time	>500ms

Input

Input Frequency	38 to 72 Hz
Nominal Input Voltage	Phase to neutral : 220/230/240 VAC (1:1) Phase to phase : 380/400/415 VAC (3:1 & 3:3)

Rack Mount Installation

Refer to the Rail Kit Installation Guide for instructions on rail installation.

⚠ CAUTION

RISK OF FALLING OBJECTS

- The equipment is heavy. Always practice safe lifting techniques adequate for the weight of the equipment.
- Always use the recommended number of screws to secure brackets to the UPS.
- Always use the recommended number of screws and cage nuts to secure the UPS to the rack.
- Always install the UPS at the bottom of the rack.
- Always install the XLBP below the UPS in the rack.

Failure to follow these instructions can result in equipment damage and minor or moderate injury.

- 1 Install the battery pack in the rack before installing the UPS in the rack.
Refer to the installation manual provided with the battery pack for detailed instructions.

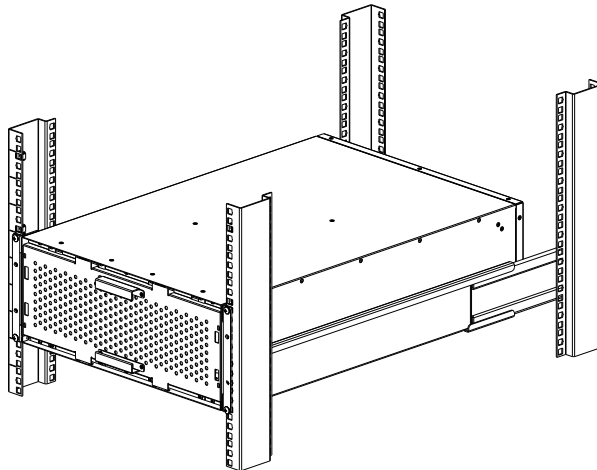

- 2 Secure the front of rail (SRTGRK1) with 6 (M5x12) screws.

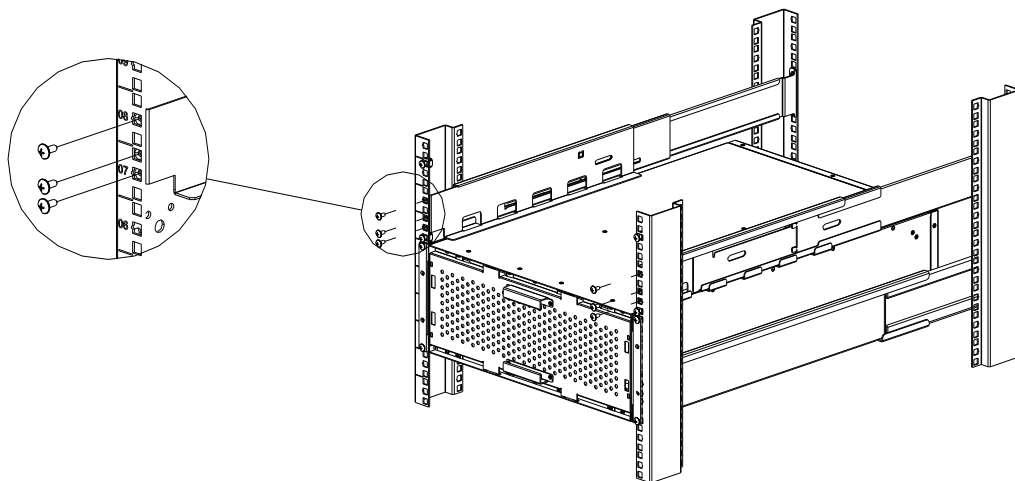

- 3 Secure the back of rail (SRTGRK1) with 6 (M5x12) screws.

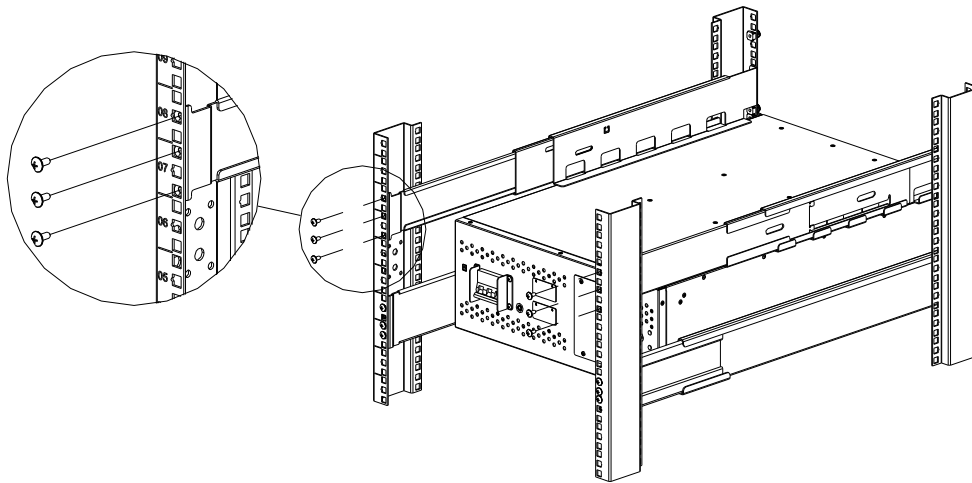

- 4 Secure the brackets on UPS module with 8 (M4x6) screws.

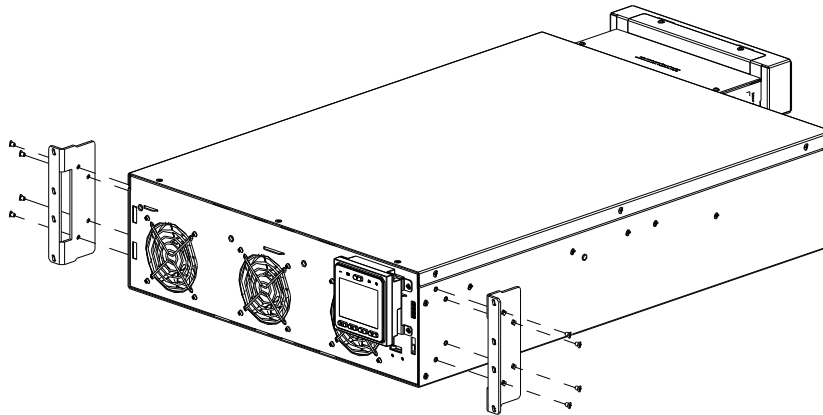

- 5 Rest the UPS module on the rail shelves.
Slide the UPS into the rack.

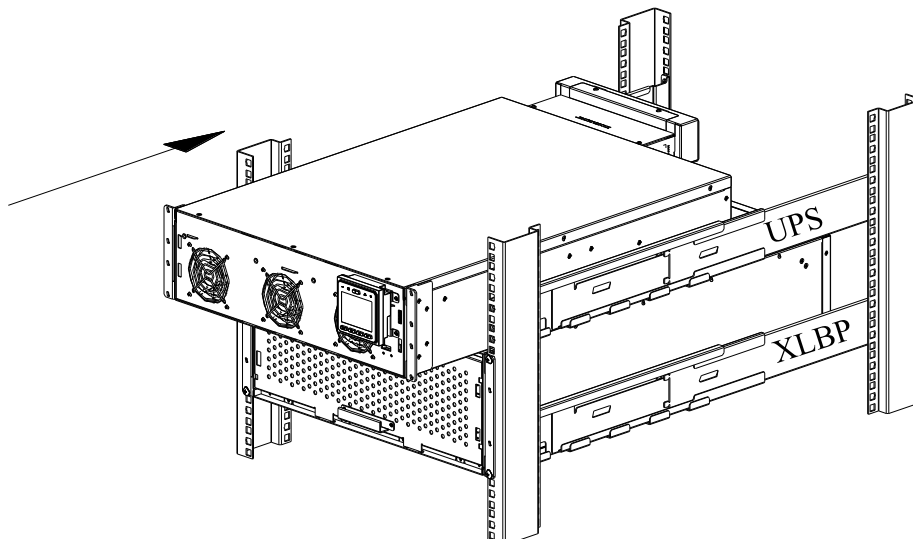

- 6 Secure brackets to the rack with 4 (M5x12) screws.

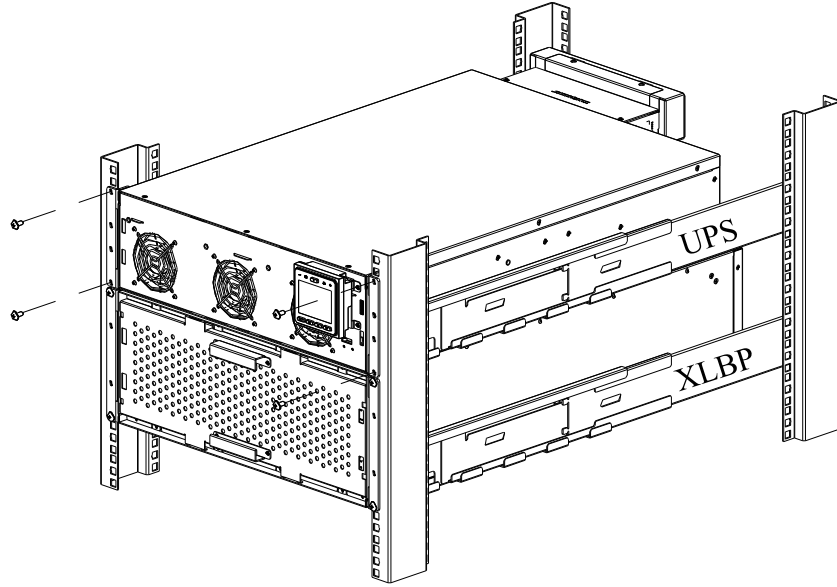

- 7 Install the front bezel of both the battery pack and the UPS.

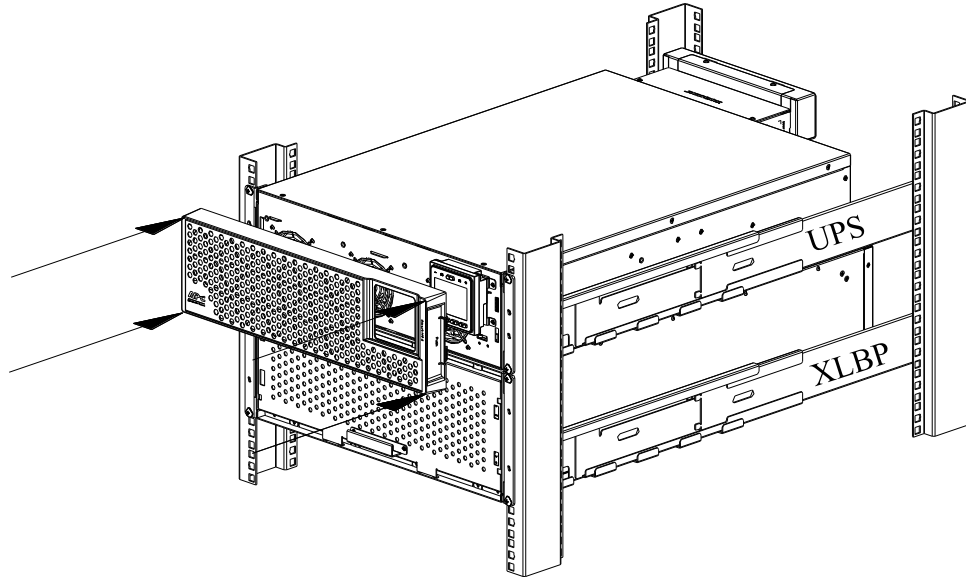

Tower Installation

⚠ CAUTION

RISK OF FALLING OBJECTS

- The equipment is heavy. Each battery module weighs 24.5 kg (54 lb).
- Always practice safe lifting techniques adequate for the weight of the equipment.
- Remove the battery modules before installing the UPS.
- Use the battery module handle to slide the battery modules in or out of the UPS.
- Do not use the battery module handle to lift or carry the battery module.

Failure to follow these instructions can result in equipment damage and minor or moderate injury.

- 1 Assemble UPS stabilizer bracket.

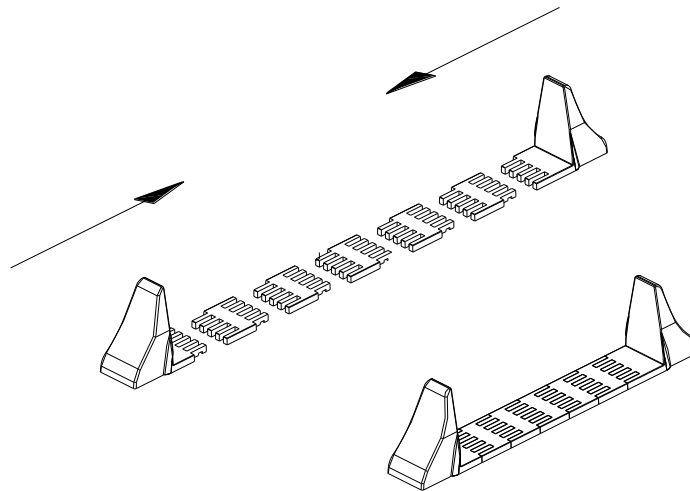

- 2 Remove the screws securing the battery compartment door and remove the battery compartment door.

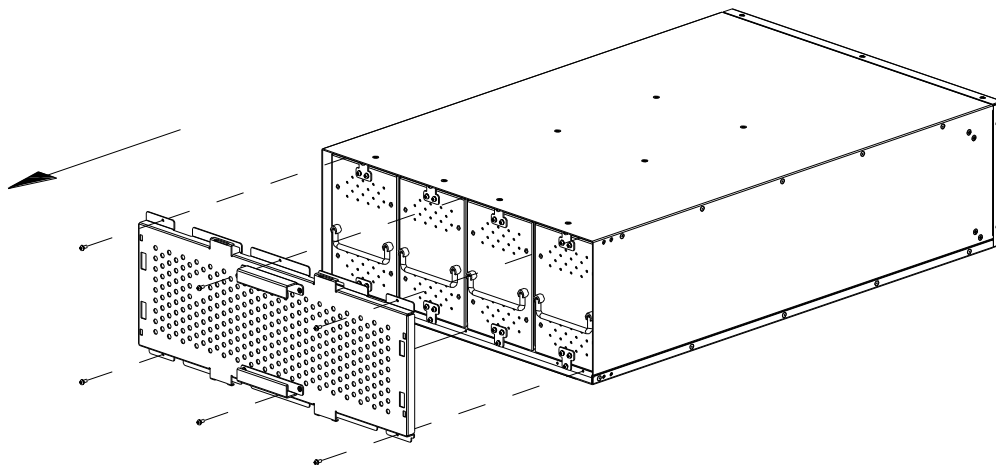

- 3 Remove the screws securing the battery modules.

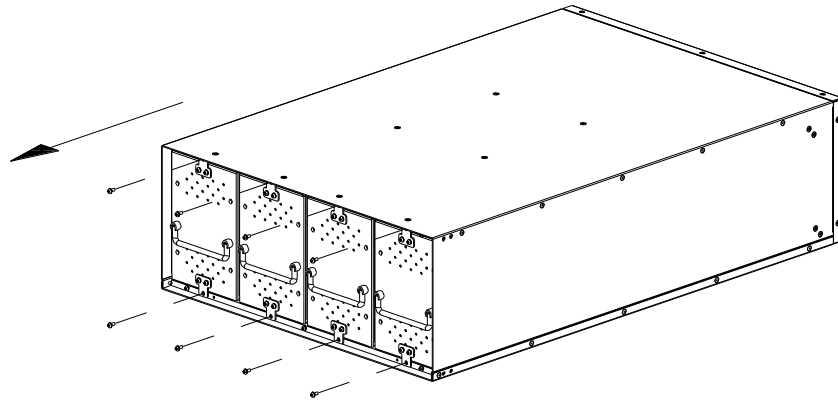

- 4 Remove the battery modules from the battery pack.

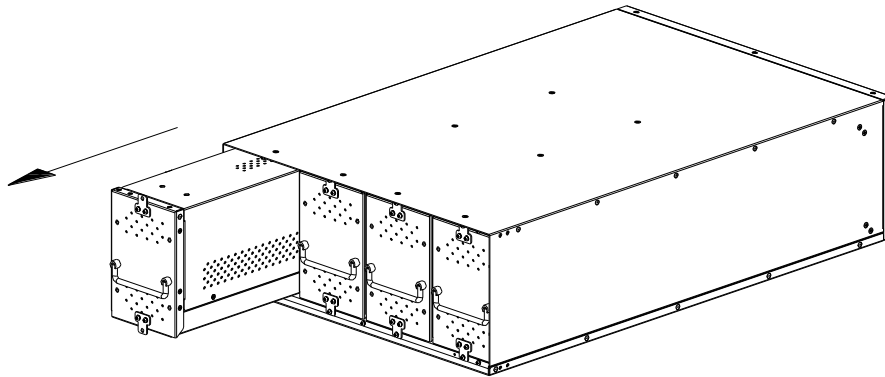

- 5 Change orientation of battery pack to tower orientation.

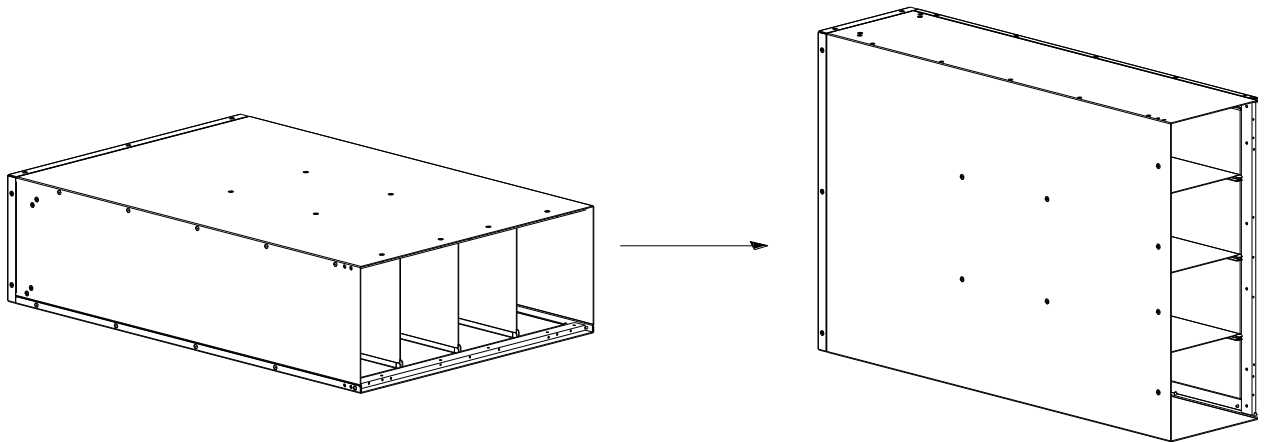

- 6 Change the orientation of the UPS to tower orientation.

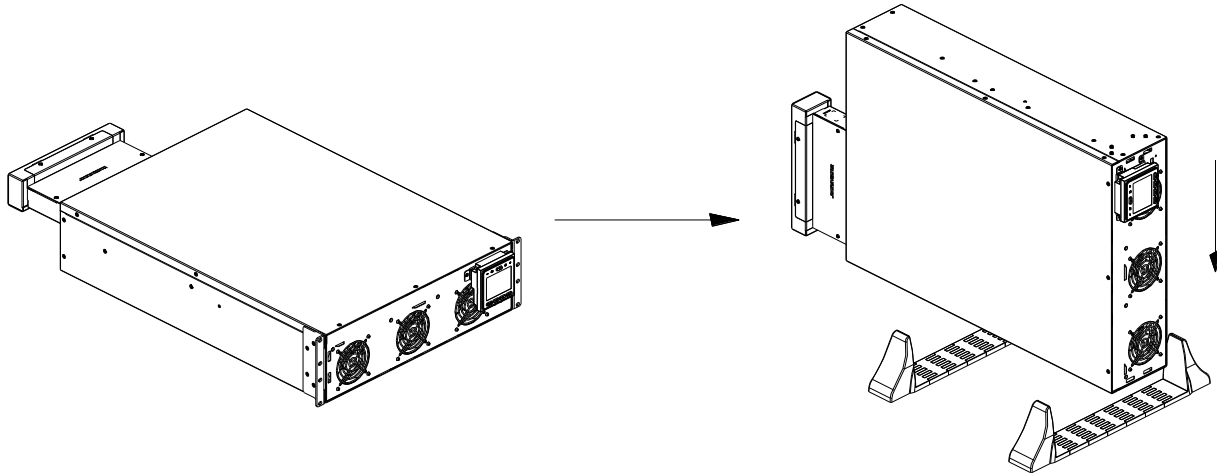

- 7 Install the UPS module and battery pack on the stabilizer brackets.

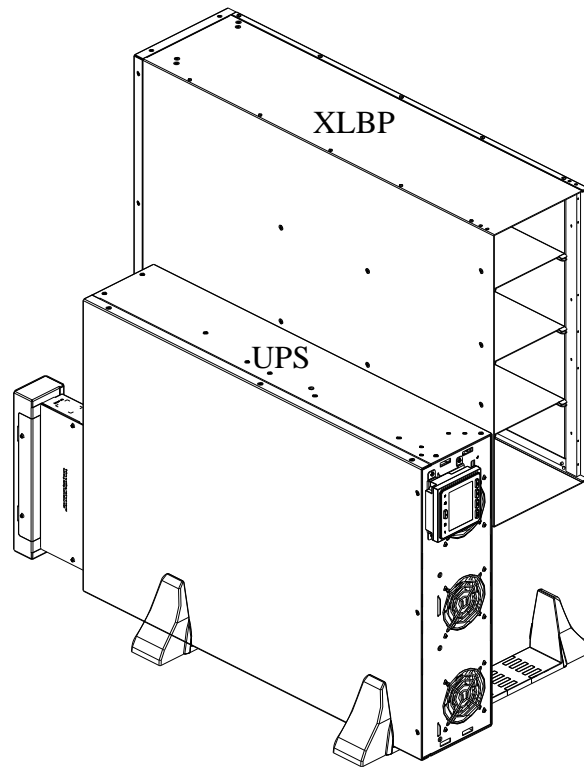

- 8 Install 4 battery modules into battery pack.

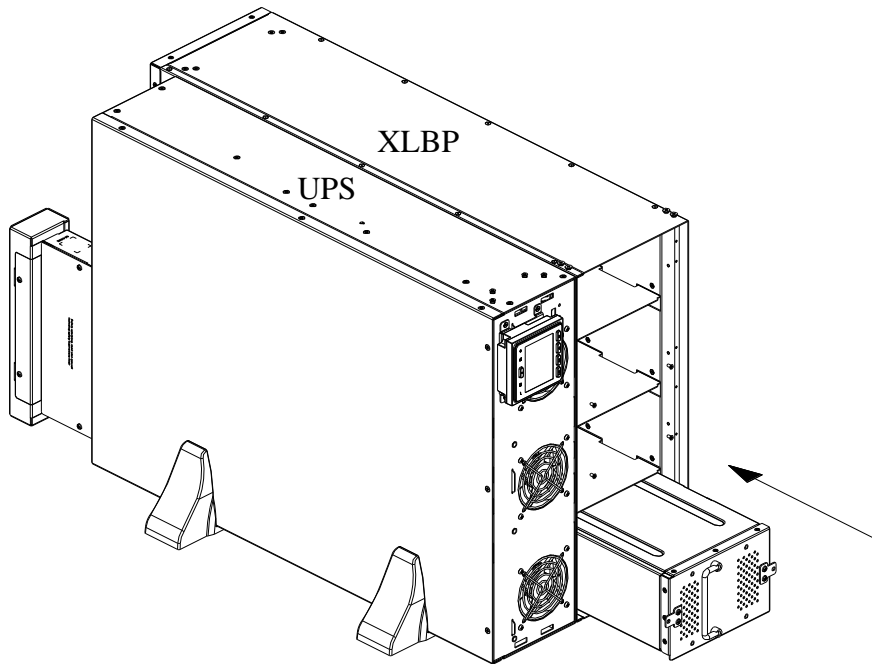

- 9 Secure the battery modules of the battery pack with 8 screws.

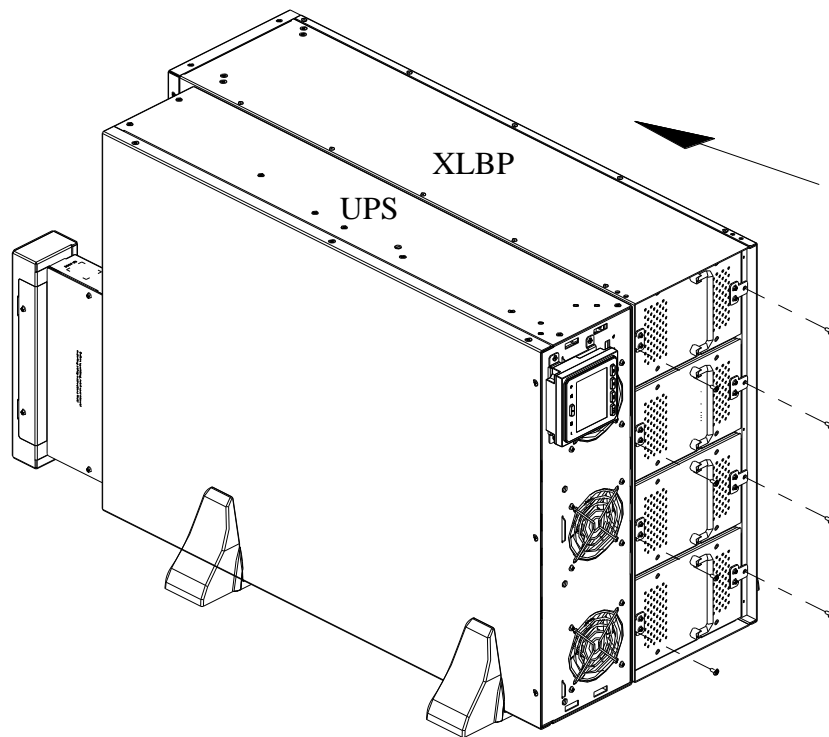

- 10 Secure the battery compartment door to the battery pack with 6 screws.

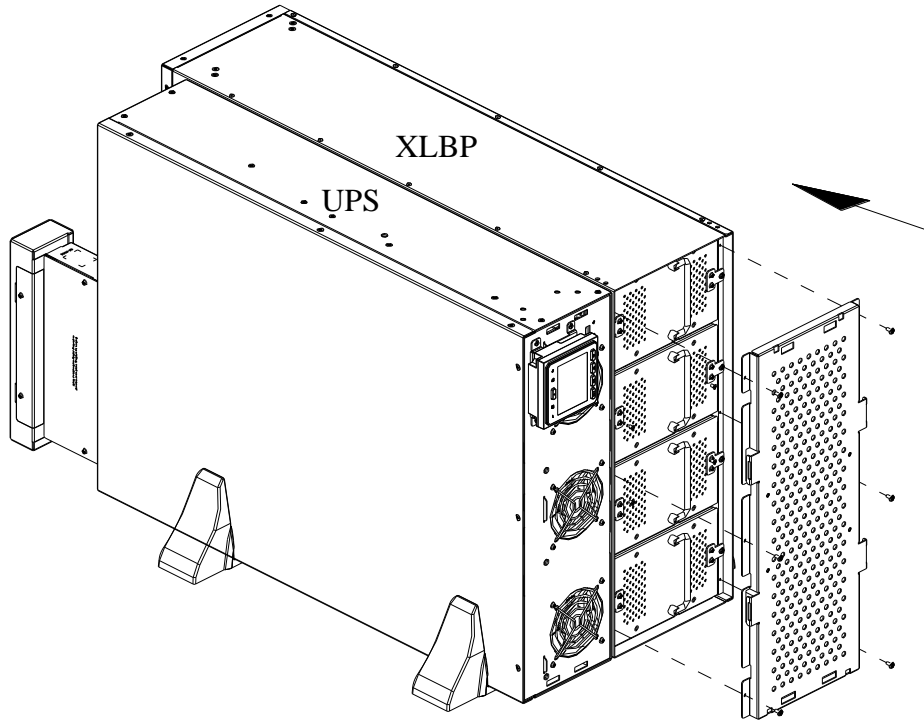

- 11 Rotate the LCD of UPS module 90 degrees to the right.

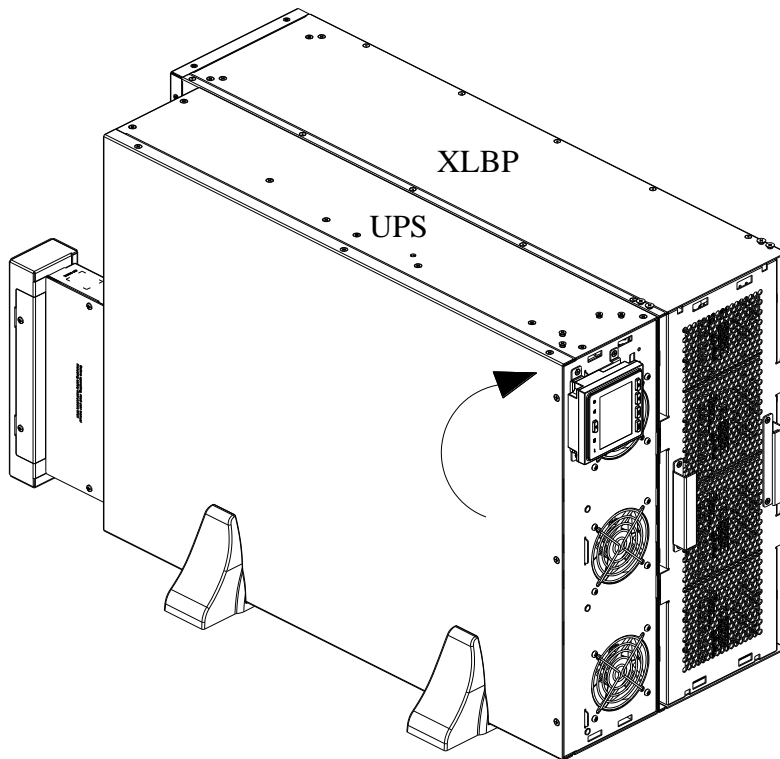

12 Install the front bezel of UPS module.

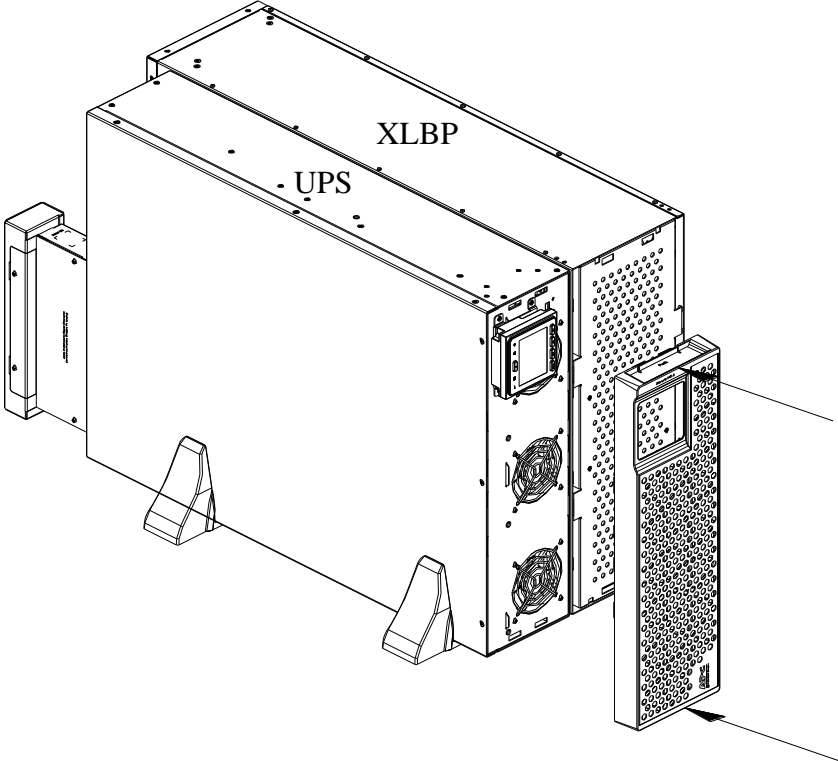

13 Install the front bezel of battery pack.

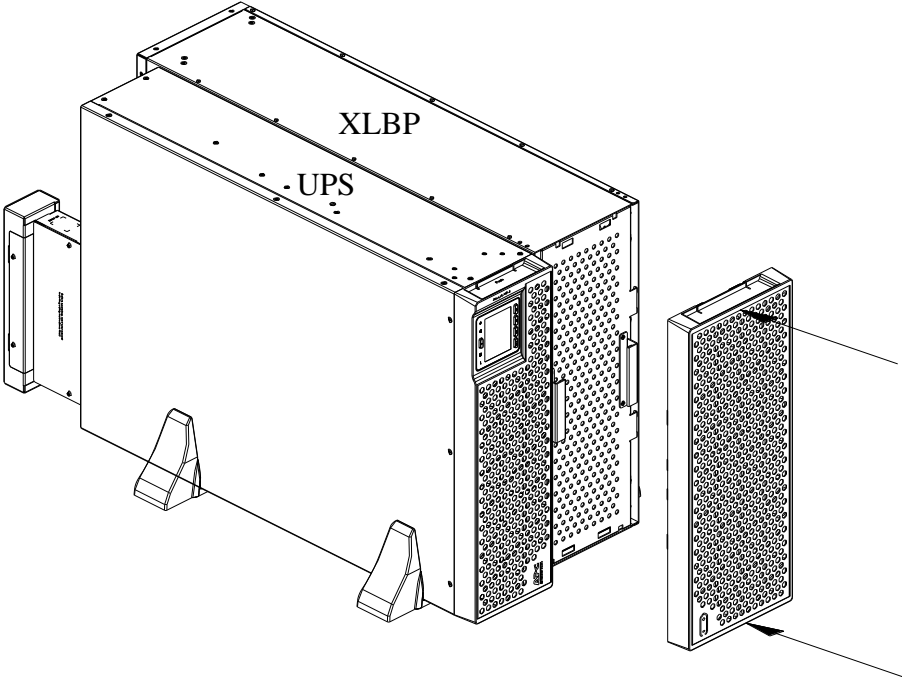

Front Panel Features

- 1 Front bezel
- 2 LCD module

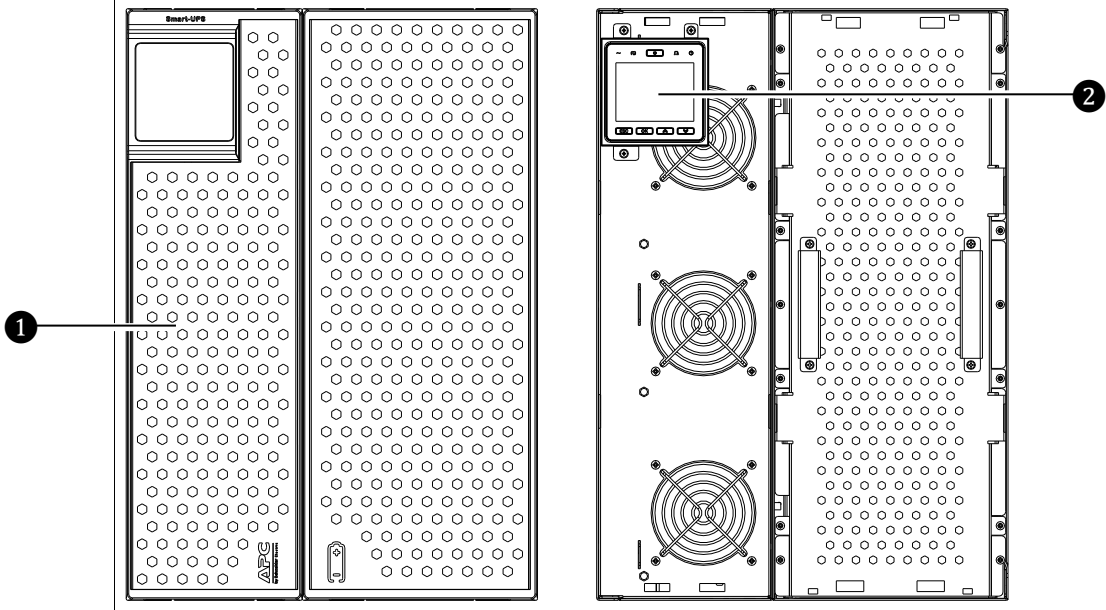
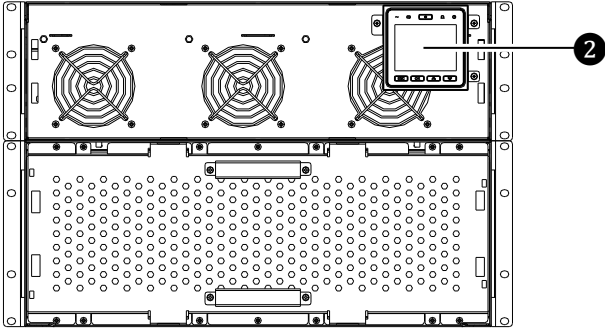
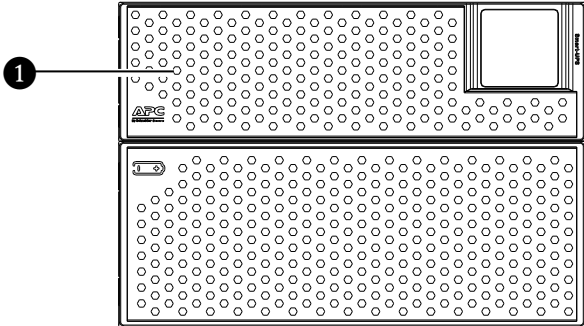

Key to identify rear panel features

①	EPO terminal	The Emergency Power Off (EPO) terminal allows the user to connect the UPS to a central EPO system.
②	MBS terminal	Maintenance bypass signal. Connect MBS cable to UPS before maintenance switch turned on. Pull out the MBS terminal when necessary to maintain the UPS.
③	BAT_T terminal	Battery temperature sensor. Connect the battery pack temperature sensor cable between ③ and ⑬.
④	RS232 port	The serial com port is used to communicate with the UPS. Use only interface kits supplied or approved by APC by Schneider Electric. Any other serial interface cable will be incompatible with the UPS connector. Note: Remote firmware upgrade facility for this UPS model is not available, user needs to use RS232 port for firmware upgrade.
⑤	USB port	Communication interface only.
⑥	Parallel Port	Parallel communication port.
⑦	Input/Output hardwire terminals	Remove the cover to connect input and output wires to the hardwire terminal blocks.
⑧	Output socket with circuit breaker.	Connect electronic devices to these outlets.
⑨	Battery Connector	External Battery input connector.
⑩	Smart Slot	The Smart Slot can be used to connect optional management accessories.
⑪	Ground screw	Connect to ground.
⑫	Battery breaker	Connects or disconnects batteries.
⑬	BAT_T	Battery temperature sensor.
⑭	Battery connector	Enables connection of battery pack to UPS or connection of additional battery packs.
⑮	Ground screw	Connect to ground.
⑯	Battery Fuse	2 nos. of 100 A / 500 Vdc fuse.

Hardwire the UPS

⚠ WARNING

RISK OF ELECTRIC SHOCK

The output sockets or terminals of the Smart-UPS can be energized when input voltage is applied to the unit.

Failure to follow these instructions can result in death or serious injury and equipment damage.

⚠ CAUTION

RISK OF ELECTRIC SHOCK

- Adhere to all national and local electrical codes.
- All electrical work must be performed by qualified electrician.
- Turn off all power to this equipment before working on the equipment. Practice lockout/tagout procedures.
- Always connect the UPS to a grounded outlet.
- Do not wear jewelry when working with electrical equipment.
- Ensure that line, neutral and ground cables of the input and output terminals are connected.
- Actual wire size must comply with required amp capacity and national and local electrical codes.
- Recommended input terminal screw torque: 4.5 Nm (40 lb-in).
- All openings that allow access to UPS hardwire terminals must be covered.
- Select wire size and connectors according to national and local codes.

Failure to follow these instructions can result in equipment damage and minor or moderate injury.

⚠ CAUTION

RISK OF FIRE

The UPS must be wired into a branch circuit, equipped with a circuit breaker rated as recommended in this manual.

Failure to follow these instructions can result in equipment damage and minor or moderate injury.

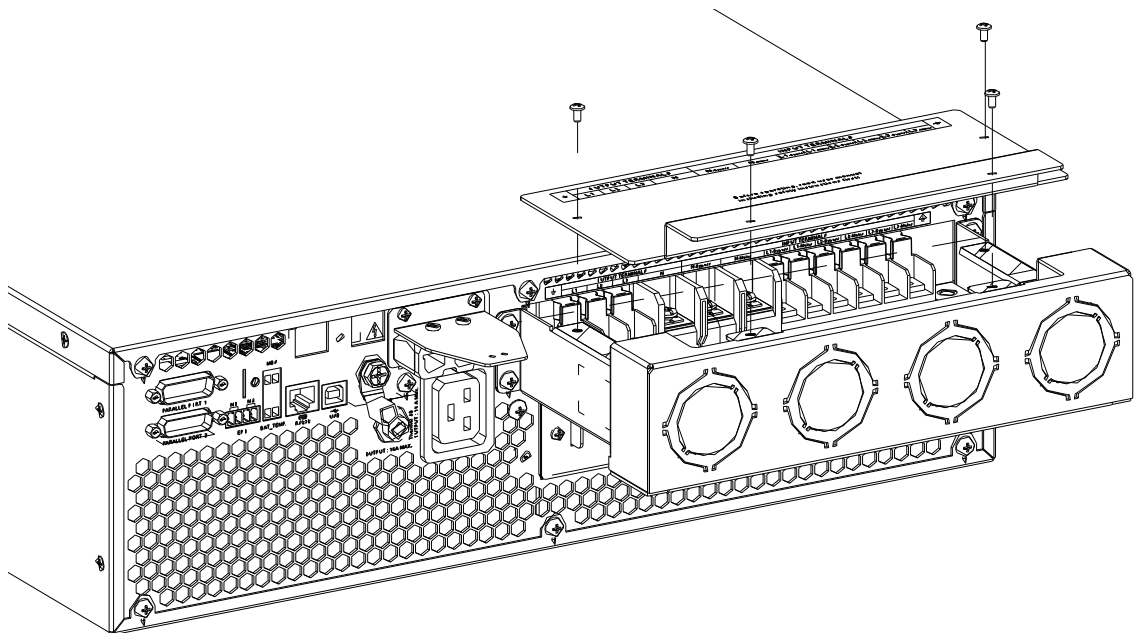

1. Install a utility circuit breaker in accordance with local electrical codes.
2. Switch the utility circuit breaker OFF, to be sure that the UPS is isolated before working on it.
3. Locate the hardwire terminal block cover on the rear panel of the UPS.
4. Remove the screws securing the cover and remove the cover.
5. Remove the appropriate jumpers for input power source compatibility and output wiring options. Refer to “Wiring specifications” on next page in this manual.
6. Insert the cables through the cable holes to the terminal blocks. Connect the ground wire first before connecting any other wire. Refer to “Wiring specifications” on next page in this manual.
7. Use an appropriate strain relief (not supplied), on the hardwired input and output power cables.
8. Replace the hardwire terminal block cover removed in step 3.

Wiring Specifications

⚠ CAUTION

RISK OF ELECTRIC SHOCK

- Adhere to all national and local electrical codes.
- Wiring should be performed by a qualified electrician.
- The UPS must be connected to a branch circuit, equipped with a circuit breaker rated as specified in the tables below.





Failure to follow these instructions can result in equipment damage and minor or moderate injury.

⚠ CAUTION

RISK OF FIRE

- In the case of “Dual input” operation, make sure the wire jumpers between each input lines have been removed.
- The AC input and the AC bypass supplies must be referenced to the same neutral point.

Failure to follow these instructions can result in equipment damage and minor or moderate injury.

Input Connections	Output Connections
Mains Input Single-Phase: Wire to L1-Mains, N-Mains, and  Three-Phase: Wire to L1-Mains, L2-Mains, L3-Mains, N-Mains, and 	Hardwire Single-Phase: Wire to L1, N, and  Three-Phase: Wire to L1, L2, L3, N, and 
Bypass Input (optional) Single-Phase: Wire to L1-Bypass, N-Bypass Three-Phase: Wire to L1-Bypass, L2-Bypass, L3-Bypass, N-Bypass	

Single Feed

	Wiring	Number of Phases	Voltage	Current Full Load*** (maximum)	External Input Circuit Breaker (typical)	Wire Size* (typical)
SRTG15KXLI	Input	1	220/230/240 VAC	100.2 A	100 A not required	25 mm ² 16 mm ²
	Output	1	220/230/240 VAC	68.2 A		
	Input	3	380/400/415 VAC	33.5 A each phase	100 A** not required	25 mm ² ** 16 mm ²
Output	1	220/230/240 VAC	68.2 A			
SRTG20KXLI	Input	3	380/400/415 VAC	33.5 A each phase	40 A each phase not required	10 mm ² 6 mm ²
	Output	3	380/400/415 VAC	22.8 A each phase		
	Input	1	220/230/240 VAC	124.1 A	125 A not required	35 mm ² 25 mm ²
	Output	1	220/230/240 VAC	90.9 A		
	Input	3	380/400/415 VAC	41.5 A each phase		
Output	1	220/230/240 VAC	90.9 A			
Input	3	380/400/415 VAC	41.5 A each phase	50 A each phase not required	16 mm ² 10 mm ²	
Output	3	380/400/415 VAC	30.4 A each phase			

Dual Feed

	Wiring	Number of Phases	Voltage	Current Full Load*** (maximum)	External Input Circuit Breaker Mains (typical)	External Input Circuit Breaker Bypass (typical)	Wire Size Mains* (typical)	Wire Size Bypass* (typical)
SRTG15K XLI	Input Output	1 1	220/230/240 VAC 220/230/240 VAC	100.2 A 68.2 A	100A not required	100A not required	25 mm ² 16 mm ²	25 mm ² 16 mm ²
	Input Output	3 1	380/400/415 VAC 220/230/240 VAC	33.5 A each phase 68.2 A	40 A each phase not required	100 A ** not required	10 mm ² 16 mm ²	25 mm ² ** 16 mm ²
	Input Output	3 3	380/400/415 VAC 380/400/415 VAC	33.5 A each phase 22.8 A each phase	40 A each phase not required	40 A each phase not required	10 mm ² 6 mm ²	10 mm ² 6 mm ²
SRTG20K XLI	Input Output	1 1	220/230/240 VAC 220/230/240 VAC	124.1 A 90.9 A	125 A not required	125 A not required	35 mm ² 25 mm ²	35 mm ² 25 mm ²
	Input Output	3 1	380/400/415 VAC 220/230/240 VAC	41.5 A each phase 90.9 A	50 A each phase not required	125 A ** not required	16 mm ² 25 mm ²	35 mm ² ** 25 mm ²
	Input Output	3 3	380/400/415 VAC 380/400/415 VAC	41.5 A each phase 30.4 A each phase	50 A each phase not required	50 A each phase not required	16 mm ² 10 mm ²	16 mm ² 10 mm ²

*Terminal screw tightening torque: 4.5Nm (40 lb-in).

**Use cables and input circuit breakers rated for specifications listed in these tables.

Note: Units configured for three phase input and single phase output operation, the entire load connected to the UPS will transfer to L1 and Neutral of the three phase input when the UPS is operating in Bypass mode.

***The current is specified at nominal input voltage.

Input / Output Wiring Options

⚠ CAUTION

RISK OF ELECTRIC SHOCK AND EQUIPMENT DAMAGE

- All electrical work must be performed by a qualified electrician.
- Turn off all power to this equipment before working on the equipment. Practice lockout/tagout procedures.
- Do not wear jewelry when working with electrical equipment.

Failure to follow these instructions can result in equipment damage and minor or moderate injury.

Input/Output wiring overview: Refer to the diagrams on the following pages for input/output wiring options.

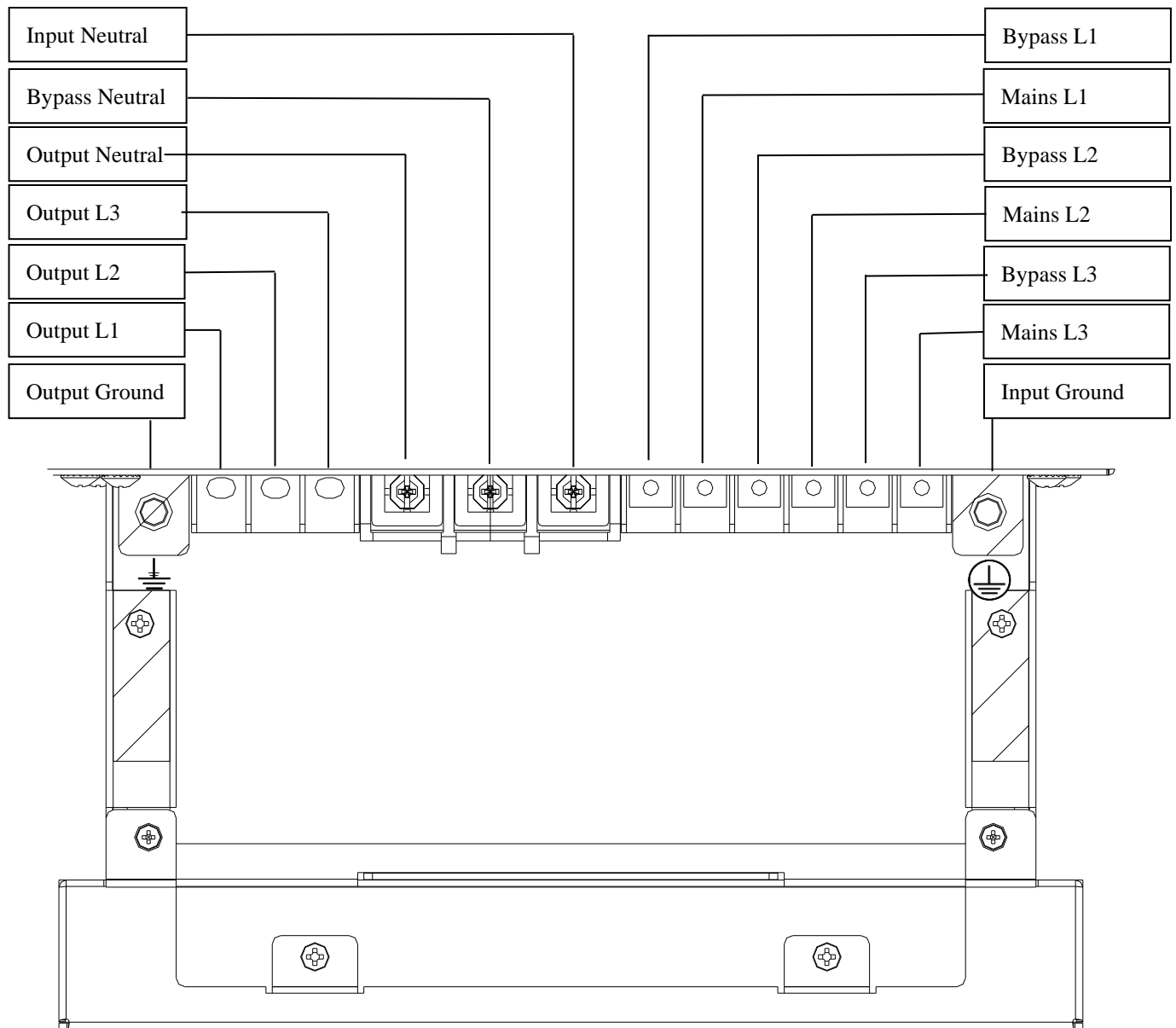

Jumpers illustration:

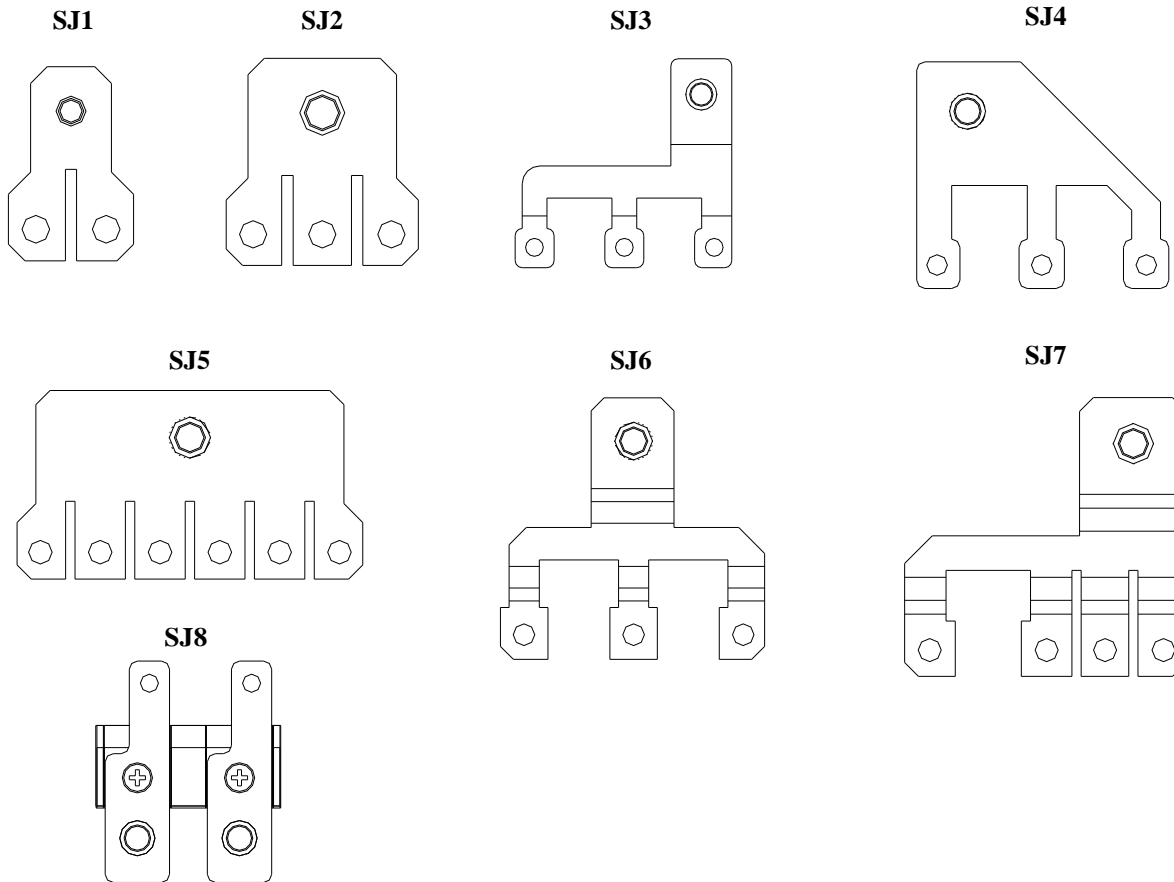

Power I/O Configuration Input:Output	Input/Output Jumper configurations								
	Separate Bypass Feed	Input Jumpers							Output Jumpers
		SJ1	SJ3	SJ4	SJ5	SJ6	SJ7	SJ8	SJ2
1:1*	No				✓				✓
1:1	Yes		✓	✓					✓
3:1	No						✓	✓	✓
3:1	Yes					✓			✓
3:3	No	✓							
3:3	Yes								
	*Factory Default								

Input wiring 1:1 single feed (Factory Default)

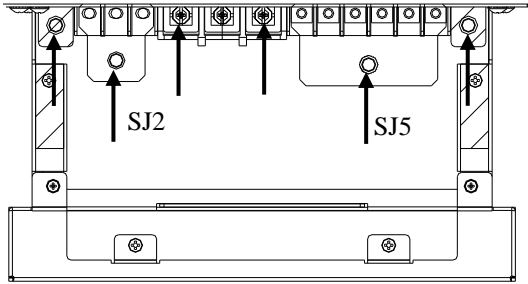

Input wiring 1:1 dual feed

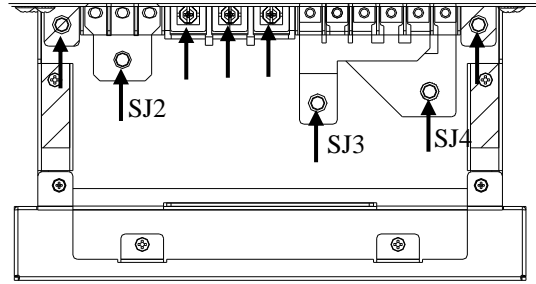

Input wiring 3:1 single feed

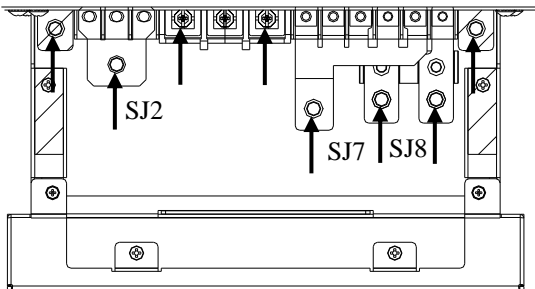

Input wiring 3:1 dual feed

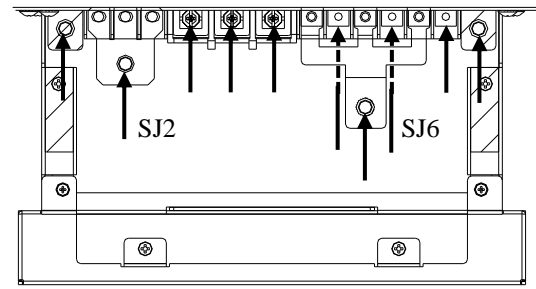

Input wiring 3:3 single feed

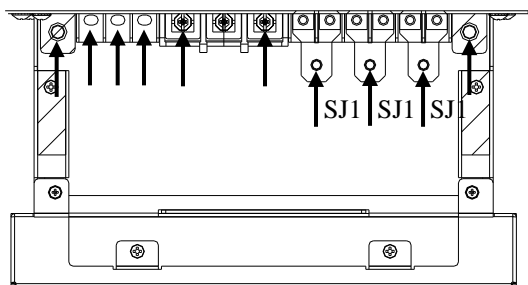

Input wiring 3:3 dual feed

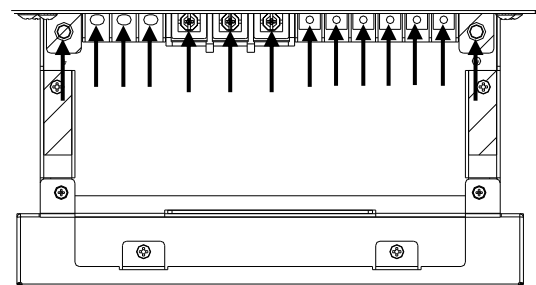

Wiring Options for Parallel Operation of UPS

Wiring specification:

	Number of Phases	Wiring		Voltage	Mains circuit		SRTG15KXLI		SRTG20KXLI		MBS Wire Size (typical)	
					Current Full Load (maximum)	Wire Size (typical)	Current Full Load (maximum)	Wire Size (typical)	Current Full Load (maximum)	Wire Size (typical)		
Single Feed	1:1	Input		220/230/240 VAC	248.2 A	120 mm ²	100.2 A	25 mm ²	124.1 A	35 mm ²	0.3 mm ²	
		Output		220/230/240 VAC	181.8 A	70 mm ²	68.2 A	16 mm ²	90.9 A	25 mm ²		
	3:1	Input	L1/N	380/400/415 VAC	248.2 A	120 mm ²	100.2 A	25 mm ²	124.1 A	35 mm ²		
			L2/L3		83 A each phase	25 mm ²	33.5 A each phase	25 mm ²	41.5 A each phase	35 mm ²		
	Output				220/230/240 VAC	181.8 A	70 mm ²	68.2 A	16 mm ²	90.9 A		25 mm ²
	3:3	Input		380/400/415 VAC		83 A each phase	25 mm ²	33.5 A each phase	10 mm ²	41.5 A each phase		16 mm ²
		Output		380/400/415 VAC		60.8 A each phase	25 mm ²	22.8 A each phase	6 mm ²	30.4 A each phase		10 mm ²
	Dual Feed	1:1	Input		220/230/240 VAC	248.2 A	120 mm ²	100.2 A	25 mm ²	124.1 A		35 mm ²
Output			220/230/240 VAC	181.8 A	70 mm ²	68.2 A	16 mm ²	90.9 A	25 mm ²			
3:1		Input	Mains	380/400/415 VAC	83 A each phase	25 mm ²	33.5 A each phase	10 mm ²	41.5 A each phase	16 mm ²		
			BPS*		248.2 A	120 mm ²	100.2 A	25 mm ²	124.1 A	35 mm ²		
Output				220/230/240 VAC	181.8 A	70 mm ²	68.2 A	16 mm ²	90.9 A	25 mm ²		
3:3		Input		380/400/415 VAC		83 A each phase	25 mm ²	33.5 A each phase	10 mm ²	41.5 A each phase	16 mm ²	
		Output		380/400/415 VAC		60.8 A each phase	25 mm ²	22.8 A each phase	6 mm ²	30.4 A each phase	10 mm ²	

*BPS mains Bypass

Emergency power off wiring

(Take 4 parallel units as an example)

Using NO contacts:

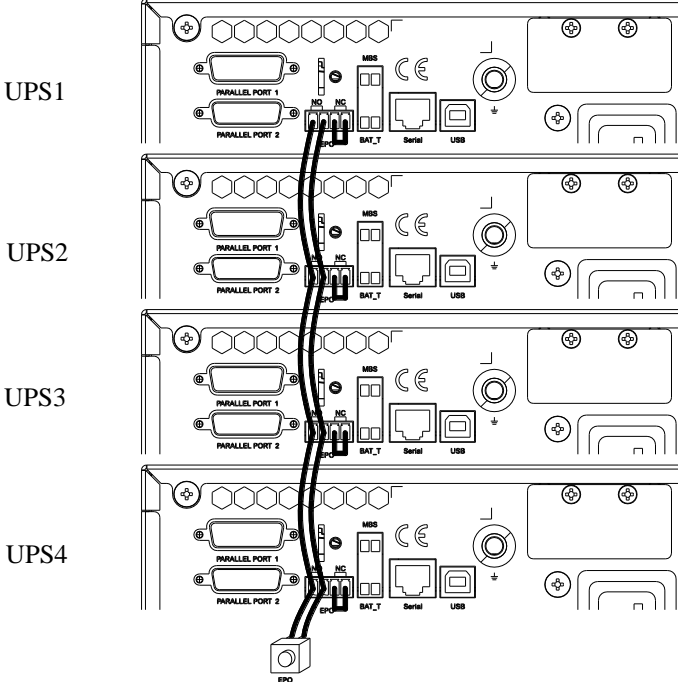

Using NC contacts:

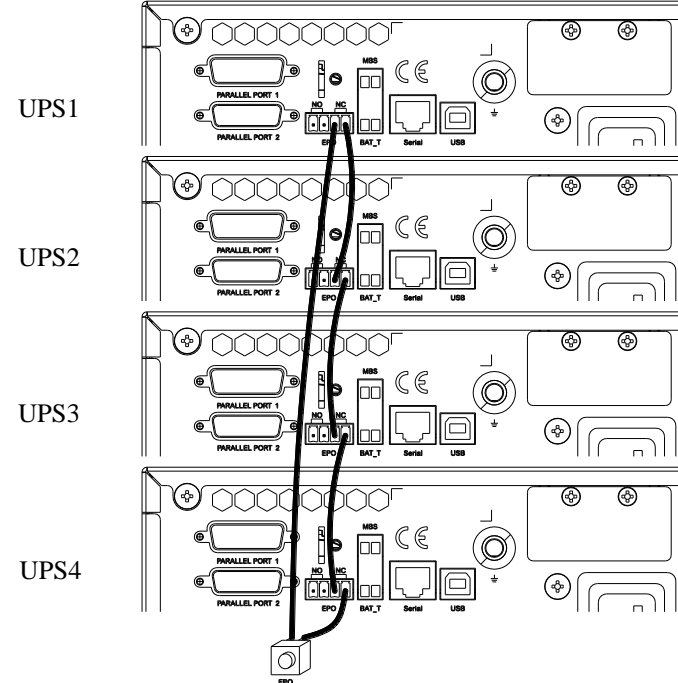

Communication cable wiring

(Take 4 parallel units as an example)

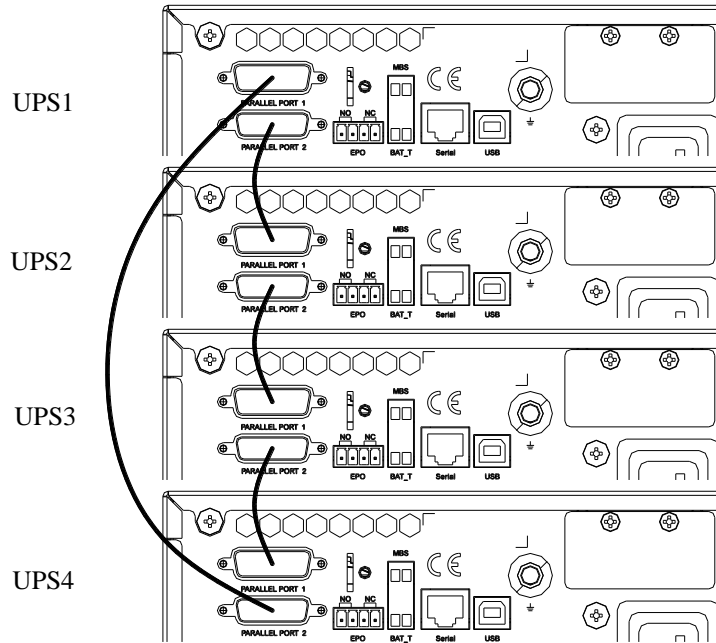

UPS Display Interface

1	Alert LED
2	Battery status icon
3	DOWN button
4	UP button
5	OK button
6	ESC button
7	Load icon
8	UPS status information
9	Operation mode information
10	Online LED
11	On Battery LED
12	POWER ON/OFF button
13	Bypass LED

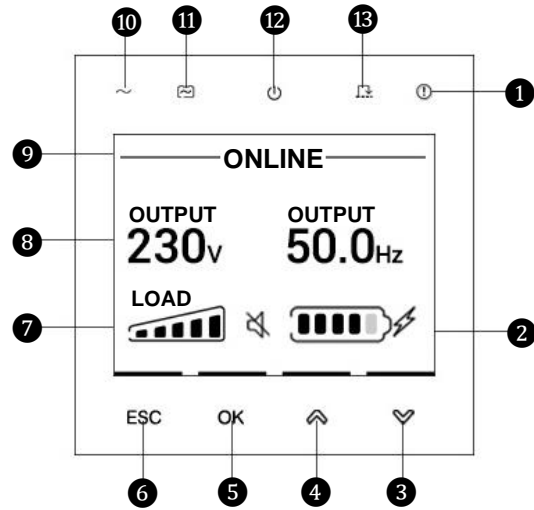

Load icon: The approximate load capacity percentage is indicated by the number of load bar sections illuminated. Each bar represents 20% of the load capacity.



Mute icon: Indicates the audible alarm is disabled/mute.

UPS status information

The status information field provides key information on the status of the UPS.



The **Mains Screen** will scroll through the following parameters :

- Input Voltage
- Input Frequency
- Output Voltage
- Output Current
- Output Frequency
- Load Active Power
- Load Apparent Power
- Load Rate
- Battery Temperature
- Battery Capacity
- Battery Runtime
- Ambient Temp.

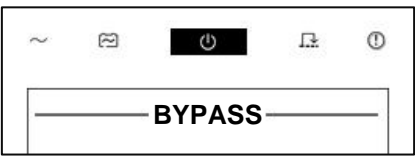

In the case of a UPS event, status updates will be displayed defining the event or condition that has occurred.

The display screen illuminates amber to indicate a precaution and red to indicate an Alert depending on the severity of the event or condition.

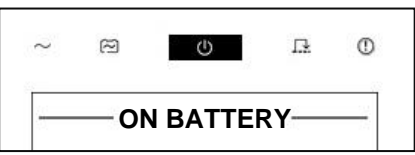
Operation mode icons

	<p>On-Line mode: The UPS is supplying conditioned mains power to connected equipment.</p>
	<p>Bypass mode: The UPS is in Bypass mode and the connected equipment will receive mains power as long as the input voltage and frequency are within the configured limits. The UPS will not switch from Bypass mode to Battery mode if mains power is not available.</p>
	<p>Green mode: In Green mode mains power is sent directly to the load. In the event of a mains power outage, there will be an interruption in power to the load of up to 10ms while the UPS switches to On-Line or Battery mode. When enabling Green mode consideration should be given to devices that may be sensitive to power fluctuations.</p>
	<p>Battery mode: The UPS is supplying battery power to connected equipment.</p>

Battery status icons

	<p>Battery Capacity: Indicates the battery power.</p>
	<p>Battery Charge In Progress: Indicates the battery is charging.</p>

Display interface operation

Use the UP/DOWN buttons to scroll through the options. Press the OK button to accept the selected option. Press the ESC button to return to the previous menu.

Menu overview

The display interface has Standard and Advanced menu screens. The preference for Standard or Advanced menu selections is made during initial installation and can be changed at any time through the Configuration menu.

The Standard menus include the most commonly used options. The Advanced menus provide additional options.

Note: Actual menu screens may differ by model and firmware version. Refer to the UPS Operation Manual for menu configuration details.

APC by Schneider Electric Worldwide Customer Support

Customer support for this or any other APC™ by Schneider Electric product is available at no charge in any of the following ways:

- Visit the APC by Schneider Electric Web site to access documents in the APC by Schneider Electric Knowledge Base and to submit customer support requests.
 - www.apc.com (Corporate Headquarters)
Connect to localized APC by Schneider Electric Web sites for specific countries, each of which provides customer support information.
 - www.apc.com/support/
Global support searching APC by Schneider Electric Knowledge Base and using e-support.
- Contact APC by Schneider Electric Customer Support Center by telephone or e-mail.
 - Local, country specific centers: go to www.apc.com/support/contact for contact information.

For information on how to obtain local customer support, contact the APC by Schneider Electric representative or other distributor from whom you purchased your APC by Schneider Electric product.

User Document Link

Refer the link or scan the QR code to access the user documentation:

SRTG15KXLI

<https://d.go2se.com/SRTG15KXLI>



SRTG20KXLI

<https://d.go2se.com/SRTG20KXLI>

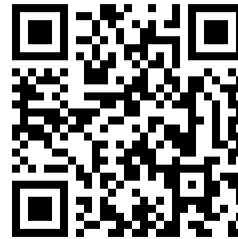

Customer support and warranty information are available on the APC by Schneider Electric Web site, www.apc.com.

© 2020 APC by Schneider Electric. APC, the APC logo, and Smart-UPS are owned by Schneider Electric Industries S.A.S., or their affiliated companies. All other trademarks are property of their respective owners.

EN 990-6203A
06/2023