

Robinson
Meier
Juilly & Associates

Sulqfls do#
Shwu#Jrelqvrq/#/H#
Ml|vrq#H#C dlqhw/#/H#



Structural Drawings For Seismic Anchorage

Prepared for:

Schneider Electric
Updated August 13, 2019
RMJ Job No. 19183
Valid Thru December 31, 2019

241 Joaquin Avenue
San Leandro, CA 94577
(510) 991-0977



GENERAL NOTES

DESIGN

This Design and design forces are based on 2012 IBC.
 This Document may only be used with the express written consent of the manufacturer listed below for the specific project site and installation location. This document is invalid without such consent.

Design Criteria:

Importance Factor1.5
 Maximum Value of $S_{DS}=2.0$, $a_p=1.0$, $R_p=2.5$, $\Omega_0=2.5$ (As req'd for anchorage to concrete), $z/h=0.0$ (Concrete slab on grade), $z/h=0.5$ (For Upper Levels)
 Forces per ASCE 7-10 section 13.3.1, Equations 13.3-1, 13.3-2 & 13.3-3.
 Note: For Site Specific S_{DS} , SEOR shall determine appropriate value to be utilized.

Dimensions: Refer to rough concrete surfaces, or top of slab, unless otherwise indicated.

Fasteners Expansion Anchors:

Anchor Diameter	Concrete Type	Min. f'c (psi)	Anchor Type	ICC Report No.	Min. Embed.	Min. Spacing	Min. Edge Dist.	Min. Conc. Thickness	Torque Test	Direction Tension
1/2"	Normal Weight	3,000	Hilti Kwik Bolt CS	ESR-1917	3 1/4"	6 1/2"	24"	6"	40 FT-LB	2,600 lb

Tension testing shall be done in the presence of the special inspector and a report of the test results shall be submitted to SEOR (After at least 24 hours have elapsed since installation, direct pull tension test or torque test at least 50% of the anchors.) Testing shall be done in the presence of Special Inspector, and a report shall be submitted to the enforcement agency.

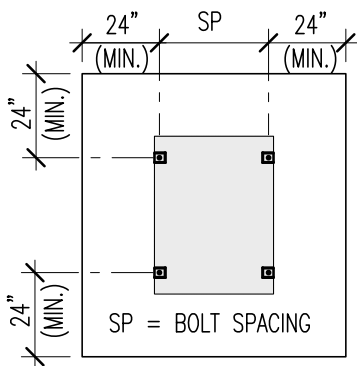

TYPICAL CONCRETE
EDGE DETAIL

Acceptance Criteria:

Direction Tension Test:

Anchor shall have maintain test load of (15) seconds & shall exhibit no discernable movement during the tension test, e.g., as evidenced by loosening of the washer under the nut.

Torque Test:

The applicable torque must be achieved within the following limits: wedge type: 1/2 turn of the nut.

*If any anchor fails testing, all anchors of the same type shall be tested, which are install by the same trade, not previously tested until twenty (20) consecutive anchors pass, then resume initial test frequency.

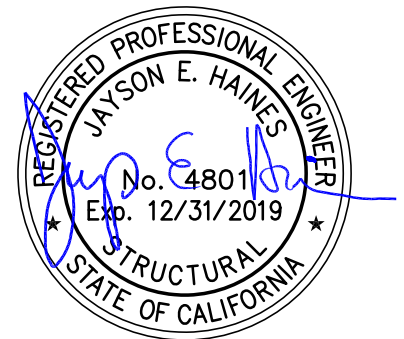

 Robinson Meier Juilly & Associates 241 Joaquin Avenue San Leandro CA 94577 510.991.0977	SCHNEIDER ELECTRIC NETSHELTER SX ANCHORAGE	Job No. 14109.01 & 19183
	LOW, MODERATE, AND HIGH SEISMIC REGIONS	Sheet No. (SK1)
	Signed by JH	Date Aug 2019

RACK MATRIX (Netshelter SX Series)

Model #	WidthXDepth	Height	U ref. per EIA-310	Weight	Anchor forces (lbs)			
					T _U	V _U	T _U	V _U
AR3abcXXXX AR9abcXXXX	600x1070	658	12	130	1220	440	625	660
		924	18	159	1220	440	625	660
		1198	24	196	1220	440	625	660
		1991	42	275	1220	440	625	660
		2124	45	300	1220	440	625	660
		2258	48	327	1220	440	625	660
		2347	50	196	1220	440	625	660
		2436	52	367	1220	440	625	660
		2525	54	389	1220	440	625	660
		600x1200	1198	24	212	1220	440	625
	600x1200	1991	42	295	1220	440	625	660
	600x1200	2124	45	322	1220	440	625	660
	600x1200	2258	48	350	1220	440	625	660
	600x1200	2347	50	372	1220	440	625	660
	600x1200	2436	52	394	1220	440	625	660
	600x1200	2525	54	417	1220	440	625	660
	750x1070	1198	24	235	1220	440	625	660
	750x1070	1991	42	335	1220	440	625	660
	750x1070	2124	45	365	1220	440	625	660
	750x1070	2258	48	398	1220	440	625	660
	750x1070	2347	50	422	1220	440	625	660
	750x1070	2436	52	447	1220	440	625	660
	750x1070	2525	54	474	1220	440	625	660
	750x1200	1198	24	251	1220	440	625	660
	750x1200	1991	42	355	1220	440	625	660
	750x1200	2124	45	387	1220	440	625	660
	750x1200	2258	48	422	1220	440	625	660
	750x1200	2347	50	447	1220	440	625	660
	750x1200	2436	52	474	1220	440	625	660
	750x1200	2525	54	502	1220	440	625	660
	800x1070	1198	24	249	1220	440	625	660
	800x1070	1991	42	355	1220	440	625	660
	800x1070	2124	45	387	1220	440	625	660
	800x1070	2258	48	422	1220	440	625	660
	800x1070	2347	50	447	1220	440	625	660
	800x1070	2436	52	474	1220	440	625	660
	800x1070	2525	54	502	1220	440	625	660
	800x1200	1198	24	265	1220	440	625	660
	800x1200	1991	42	375	1220	440	625	660
	800x1200	2124	45	409	1220	440	625	660
	800x1200	2258	48	446	1220	440	625	660
	800x1200	2347	50	472	1220	440	625	660
	800x1200	2436	52	501	1220	440	625	660
	800x1200	2525	54	531	1220	440	625	660
	600x900	658	12	119	1220	440	625	660
	600x900	924	18	148	1220	440	625	660

← Maximum anchor value for either a single unit or set of ganged units. 600 mm units must ganged at ground floor; Single 600mm units not allowed at ground floor.

AR3abc and AR9abc XXXXXX Series cabinets defined by:

a denotes depth:
 0 35.4" (900 mm) deep
 1 or 2 42.1" (1070 mm) deep
 3 47.2" (1200 mm) deep

b denotes width:
 0 or 1 23.6" (600mm) wide
 4 or 5 29.5" (750 mm) wide
 8 31.5" (800 mm) wide

c denotes height:
 0, 1 or 2 78.4" (1991 mm) high for 42U
 3 25.9" (658 mm) high for 12U
 4 47.2" (1198 mm) high for 24U
 5 83.6" (2124 mm) high for 45U
 6 36.4" (924 mm) high for 18U
 7 88.9" (2258 mm) high for 48U
 8 95.9" (2436 mm) high for 52U
 9 99.4" (2525 mm) high for 54U

Note: U designations are per EIA-310
 EIA is Electronic Industries Association

U reference is depth of cabinet per Electronic Industries Alliance.

FOR PLAN REFERENCE, SEE SHEET SK4

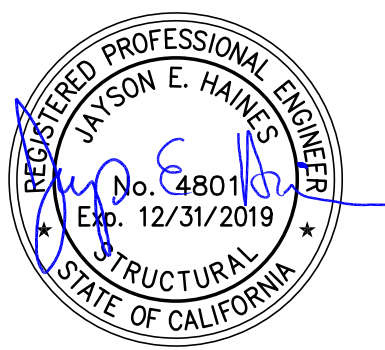

<p>Robinson Meier Julliy & Associates 241 Joaquin Avenue San Leandro CA 94577 510.991.0977</p>	<p>SCHNEIDER ELECTRIC NETSHELTER SX ANCHORAGE</p>	<p>Job No. 14109.01 & 19183</p>
	<p>LOW, MODERATE, AND HIGH SEISMIC REGIONS</p>	<p>Sheet No.</p>
	<p>Signed by JH Date Aug 2019</p>	<p>\$K10</p>

Test Loads:

Calculations are in accordance with the 2012 International Building Code.

The details are applicable to locations in the United States of California where S_{DS} is not greater than 2.0. For site specific S_{DS} , SEOR shall determine appropriate value to be utilized. Locations determined to be risk category IV not covered under this package.

Anchor forces shown on the drawings are factored loads that shall be used for strength design.

Package only covers only the supports & attachments of the unit to the structure.

RESPONSIBILITY OF STRUCTURAL ENGINEER OF RECORD

1. Verify that the concrete meets the requirements of the applicable ICC ESR.
2. Verify that the anchors are at an adequate distance from any slab opening or edges.
3. Verify that all new or existing anchors are at an adequate distance from the anchors shown in this pre-approval. The SEOR shall verify that there is no adverse interaction where other anchors are within 18" or $6 h_{ef}$ from the unit's anchors.
4. Verify the adequacy of the structure to support the weight and forces shown here in addition to all other weights and forces that are imposed on it.
5. Provide any supplementary structure required for strength and stability.
6. Verify that the installation is in conformance with the 2012 IBC and with the notes and details shown in this pre-approval. Verify that the equipment's actual weight, center of gravity location, anchor locations, anchor details and the material and gage of the unit where attachments are made conform with the information shown in this pre-approval.
7. If content weight is less than 33 pcf, maximum live loads permitted shall be posted.



 Robinson Meier Jully & Associates 241 Joaquin Avenue San Leandro CA 94577 510.991.0977	SCHNEIDER ELECTRIC NETSHELTER SX ANCHORAGE	Job No. 14109.01 & 19183
	LOW, MODERATE, AND HIGH SEISMIC REGIONS	Sheet No.
	Signed by JH Date Aug 2019	(SK2)

SEISMIC SUPPORT & ANCHORAGE

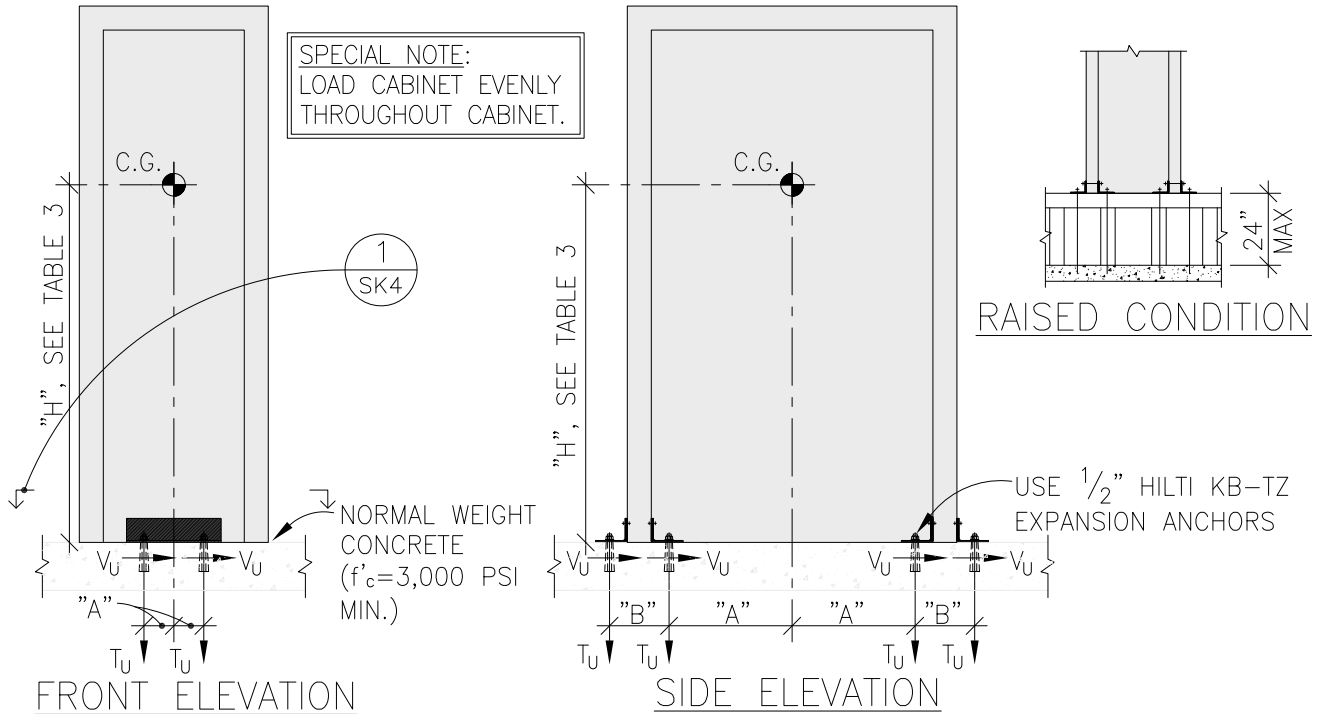

NOTES:

1. DESIGN CENTER OF GRAVITY AT 1/2 THE HEIGHT OF THE UNIT. (NOTE: ACTUAL CENTER OF GRAVITY DOES NOT EXCEED DESIGN HEIGHT.)
2. FORCES ARE DETERMINED PER 2012 INTERNATIONAL BUILDING CODE AND ASCE 7-10 STRENGTH DESIGN. ($S_{DS}=2.0$ (HIGH SEISMIC) 1.0 (LOW SEISMIC), $a_p=1.0$, $I_p=1.5$, $R_p=2.5$, $\Omega_0=2.5$, $z/h=0$ (GROUND LEVEL) & $z/h=.5$ (50% OF BLDG. HT.)).
3. SEE GENERAL NOTES FOR ALL OTHER CONDITIONS AND LIMITATIONS.
4. NETSHELTER SX EXTERIOR CABINET UNIT COVER COMPOSED OF 14 ga COLD ROLLED STEEL 29.4 ksi.
5. SIGN MUST BE POSTED INDICATING CABINET TOTAL WT. LIMITS LISTED IN THE TABLE 1.
6. WEIGHTS LISTED IN "TABLE 1" APPLY TO ALL UNITS IRRESPECTIVE OF SIZE.

MAXIMUM CABINET CONTENT WEIGHT LB (TABLE 1)

ALLOWABLE CABINET ADDED WEIGHT *ALL WEIGHTS GIVEN IN (LB) TABLE 1

MAX CABINET WT. (500)	LOW & MODERATE SEISMIC				HIGH SEISMIC			
	GROUND		UPPER		GROUND		UPPER	
	ON FLOOR	RAISED	ON FLOOR	RAISED	ON FLOOR	RAISED	ON FLOOR	RAISED
SINGLE UNIT	1,500	850	1,200	1,200	1,000	SS ¹	1,200	1,200
GANGED UNIT	2,000	2,000	1,200	1,200	1,500	1,500	1,200	1,200
12u/18u	600/900		600/900		600/900		600/900	

(INCLUDES Ω_0 FOR ANCHORAGE TO CONCRETE)



DIMENSIONS, AND DEMAND LOADING (TABLE 2)

COVERS ALL SCHNEIDER ELECTRIC NETSHELTER SX UNITS WITH-IN THE FOLLOWING DIMENSIONS FOR 600x1070 and 600x900 UNITS	CABINET DIMENSIONS		
	WIDTH (in.)	DEPTH (in.)	HEIGHT (in.)
	23.6-31.5	42.1-51.2	47.17-99.6
23.6	31.5-35.4	25.9-36.4	

<p>Robinson Meier Juilly & Associates 241 Joaquin Avenue San Leandro CA 94577 510.991.0977</p>	<p>SCHNEIDER ELECTRIC NETSHELTER SX ANCHORAGE</p>	<p>Job No. 14109.01 & 19183</p>
	<p>LOW, MODERATE, AND HIGH SEISMIC REGIONS</p>	<p>Sheet No. (SK3)</p>
	<p>Signed by MAS Date Aug 2019</p>	

NOTES:

- *POSITION BOLTS IN OUTER OR UPPER HALF OF SLOTTED BOLT HOLES WHERE APPLICABLE
- *SEE MANUFACTURE DRAWINGS FOR EXACT DIMENSIONS OF NETSHELTER SX CABINETS. AR3100 SHOWN FOR REFERENCE.
- *INTERNAL BRACKET INSTALLATION SHOWN HERE. CLIENT HAS OPTION TO USE EXTERNAL BRACKET INSTALLATION.

CONDITION SCHEDULE

CONDITION	SEE
CONCRETE SLAB	(SK6)
CONCRETE FILL OVER METAL DECK	(SK7)
RAISED COMP. FLOOR CONC. FILL METAL DECK	(SK8)
RAISED COMP. FLOOR CONC. SLAB	(SK9)

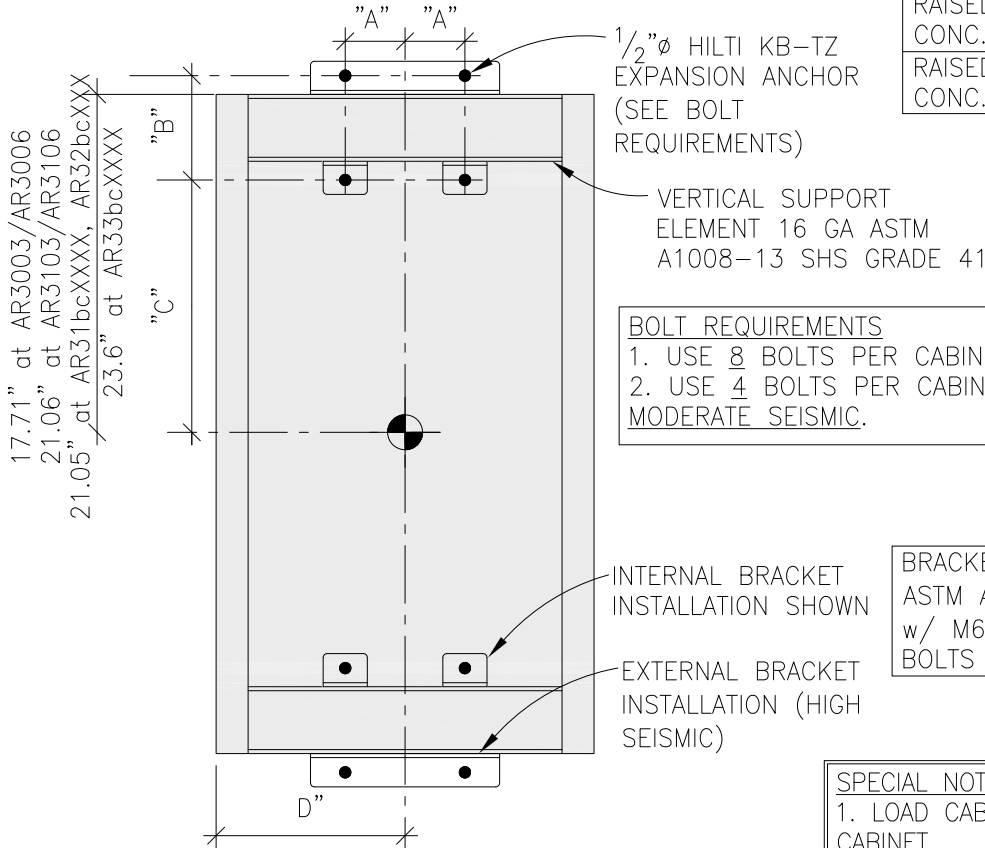

BOLT REQUIREMENTS

1. USE 8 BOLTS PER CABINET FOR HIGH SEISMIC.
2. USE 4 BOLTS PER CABINET FOR LOW AND MODERATE SEISMIC.

BRACKET MATERIAL (0.135" THK, ASTM A1008-13 SHS GRADE 41) w/ M6 (ISO 898-1 CLASS 10.9) BOLTS PROVIDED BY NETSHELTER.

SPECIAL NOTES:

1. LOAD CABINET EVENLY THROUGHOUT CABINET.
2. FOR HIGH SEISMIC USE 4 BRACKET SHOWN ON SK4.

SINGLE UNIT BOTTOM PLAN VIEW

PLAN

N.T.S.

1
SK4

ANCHOR BOLT DIMENSIONS TABLE 3

"H"	"A"	"B"	"C"	"D"
MAX (in.)	MAX (in.)	MAX (in.)	MAX (in.)	MAX (in.)
59.3"	3.74"	5.9"	15.03"	15.75"

WORST CASE VALUES



<p>Robinson Meier Juilly & Associates</p> <p>Structural Engineers</p> <p>241 Joaquin Avenue San Leandro CA 94577 510.991.0977</p>	<p>SCHNEIDER ELECTRIC NETSHELTER SX ANCHORAGE</p>	<p>Job No. 14109.01 & 19183</p>
	<p>LOW, MODERATE, AND HIGH SEISMIC REGIONS</p>	<p>Sheet No. (SK4)</p>
	<p>Signed by JH Date Aug 2019</p>	

NOTES:

- *POSITION BOLTS IN OUTER OR UPPER HALF OF SLOTTED BOLT HOLES WHERE APPLICABLE
- *SEE MANUFACTURE DRAWINGS FOR EXACT DIMENSIONS OF NETSHELTER SX CABINETS. AR3100 SHOWN FOR REFERENCE.
- *INTERNAL BRACKET INSTALLATION SHOWN HERE. CLIENT HAS OPTION TO USE EXTERNAL BRACKET INSTALLATION.

CONDITION SCHEDULE

CONDITION	SEE
CONCRETE SLAB	(SK6)
CONCRETE FILL OVER METAL DECK	(SK7)
RAISED COMP. FLOOR CONC. FILL METAL DECK	(SK8)
RAISED COMP. FLOOR CONC. SLAB	(SK9)

INSTALLATION FOR THE FOLLOWING CONDITIONS:

1. SEE BOLT REQUIREMENTS ON SK4 FOR ANCHORAGE REQUIREMENTS.

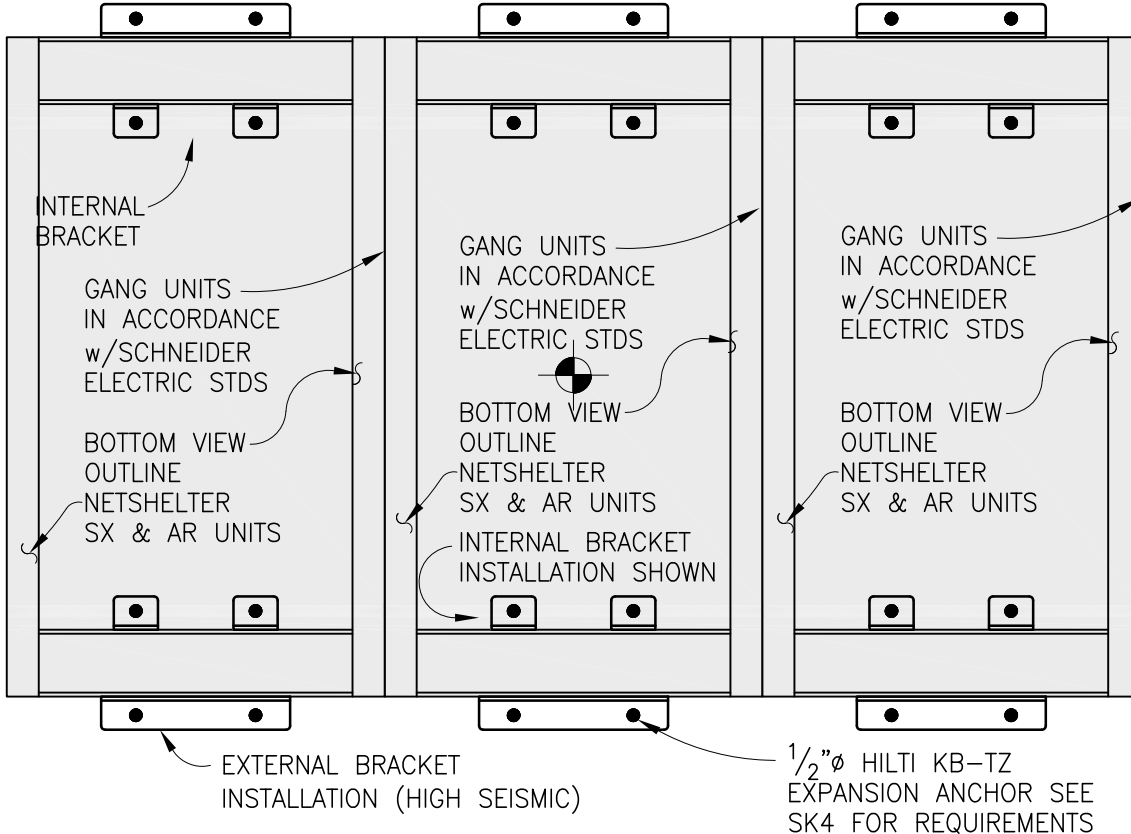

GANG UNIT BOTTOM PLAN VIEW (3 UNITS OR MORE GANGED TOGETHER)



PLAN

N.T.S.

1
SK5

SPECIAL NOTES:

1. LOAD CABINET EVENLY THROUGHOUT CABINET.
2. FOR HIGH SEISMIC USE 4 BRACKET SHOWN ON SK4 FOR EA UNIT.

<p>Robinson Meier Juilly & Associates 241 Joaquin Avenue San Leandro CA 94577 510.991.0977</p>	<p>SCHNEIDER ELECTRIC NETSHELTER SX ANCHORAGE</p>	<p>Job No. 14109.01 & 19183</p>
	<p>LOW, MODERATE, AND HIGH SEISMIC REGIONS</p>	<p>Sheet No. (SK5)</p>
	<p>Signed by JH Date Aug 2019</p>	

NOTE:
 OPTIONAL EXTERNAL
 INSTALLATION SHOWN DASHED.

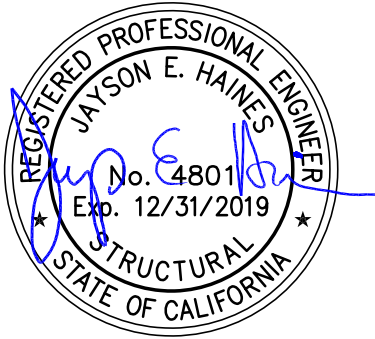
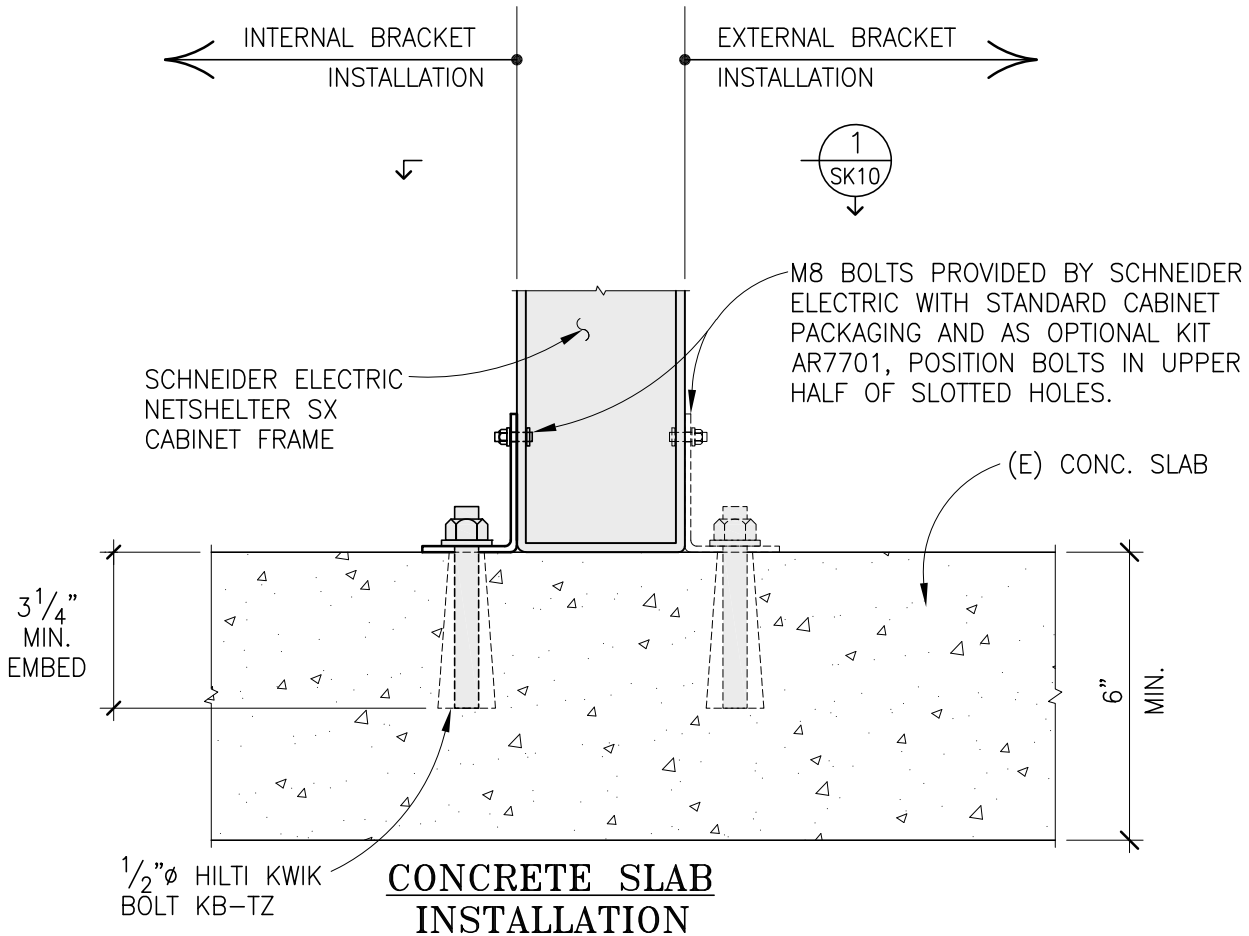

DETAIL

1
 SK6

3" = 1'-0"

 Robinson Meier Juilly & Associates 241 Joaquin Avenue San Leandro CA 94577 510.991.0977	SCHNEIDER ELECTRIC NETSHELTER SX ANCHORAGE	Job No. 14109.01 & 19183
	LOW, MODERATE, AND HIGH SEISMIC REGIONS	Sheet No. SK6
	Signed by JH	Date Aug 2019

NOTE:
 OPTIONAL EXTERNAL
 INSTALLATION SHOWN DASHED.

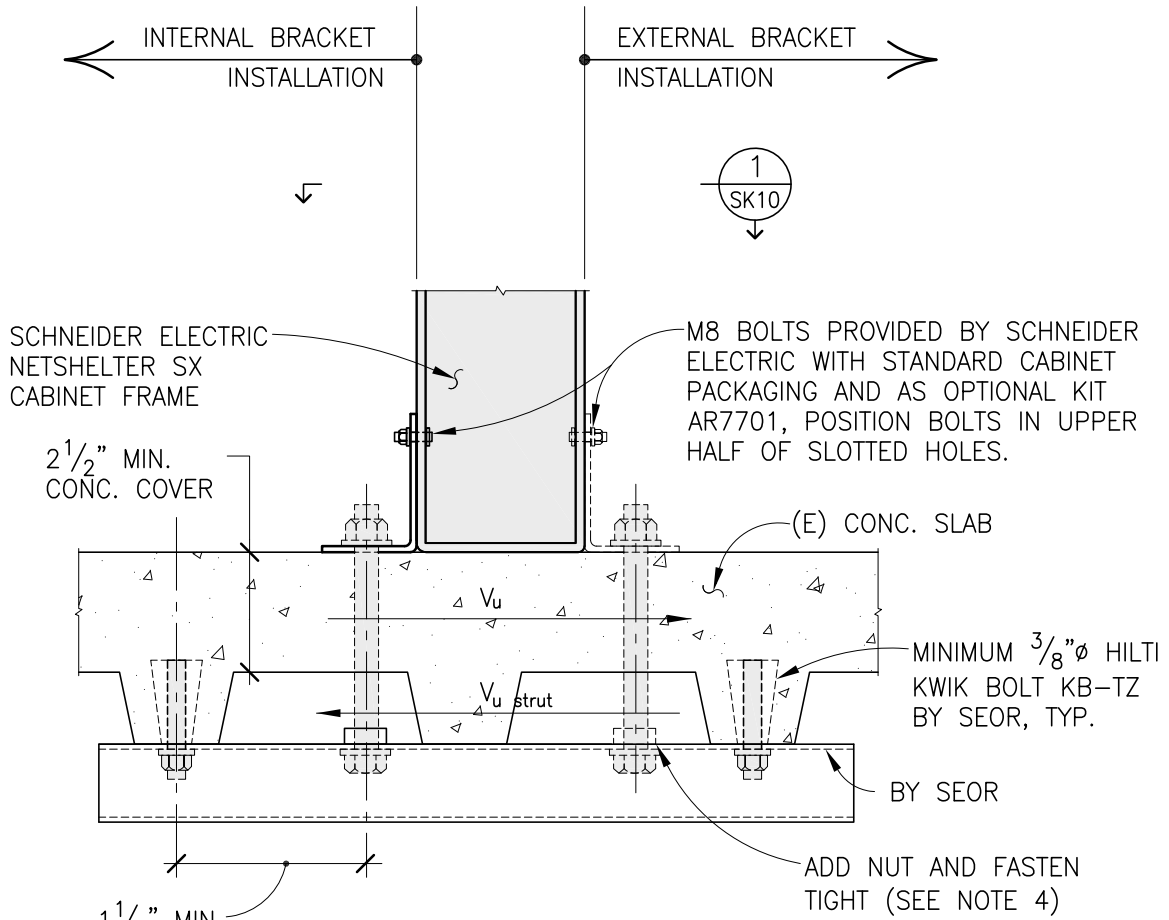

**CONCRETE FILL OVER METAL
 DECK INSTALLATION**

DETAIL 1
 3" = 1'-0" SK7



 Robinson Meier Juilly & Associates 241 Joaquin Avenue San Leandro CA 94577 510.991.0977	SCHNEIDER ELECTRIC NETSHELTER SX ANCHORAGE	Job No. 14109.01 & 19183
	LOW, MODERATE, AND HIGH SEISMIC REGIONS	Sheet No. SK7
	Signed by JH Date Aug 2019	

NOTE:
 OPTIONAL EXTERNAL
 INSTALLATION SHOWN DASHED.

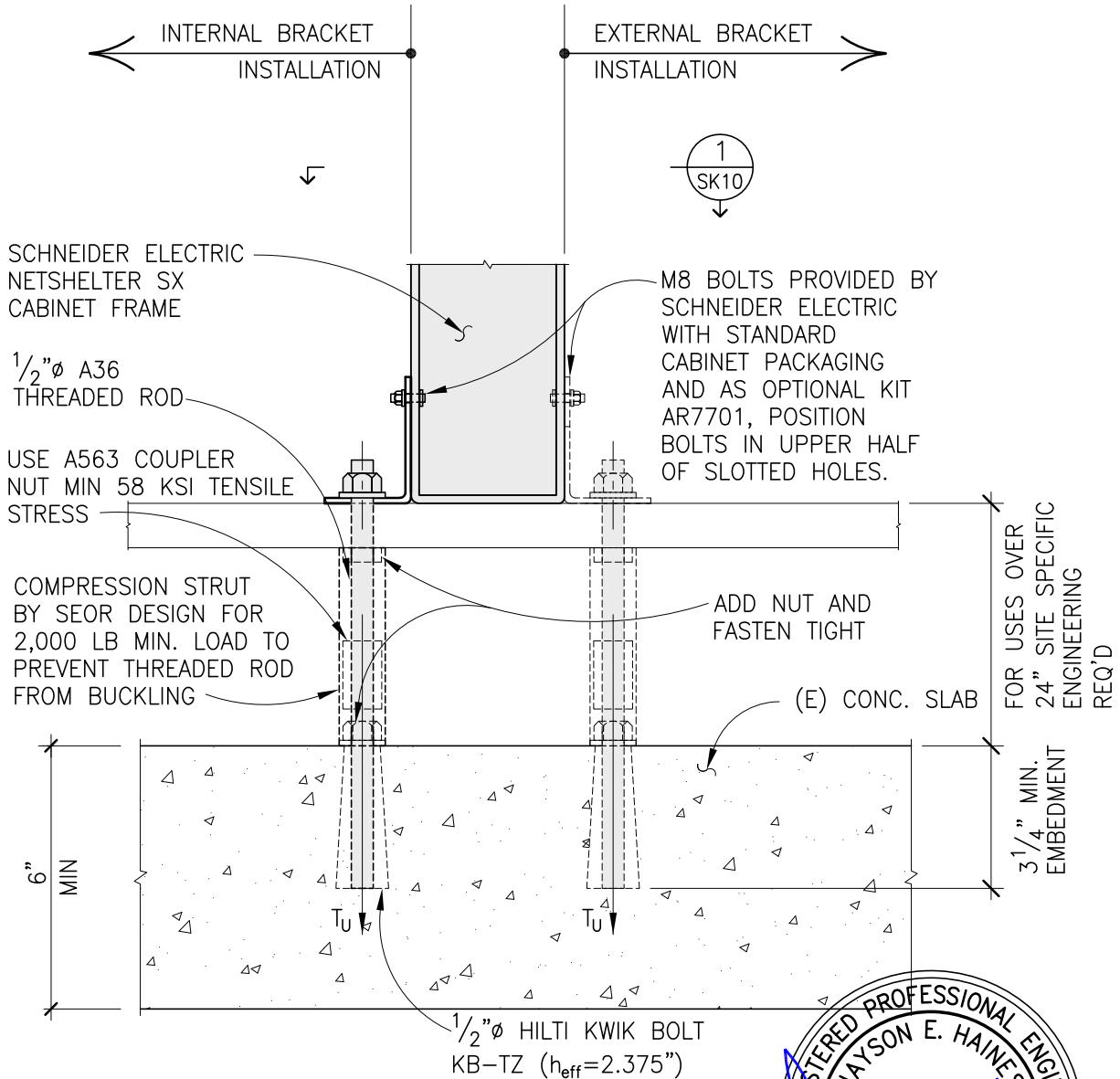

**RAISED COMPUTER OVER
 SLAB INSTALLATION**

DETAIL 1
 3" = 1'-0" SK9



FOR USES OVER
 24" SITE SPECIFIC
 ENGINEERING
 REQ'D
 3 1/4" MIN.
 EMBEDMENT

 Robinson Meier Jullily & Associates 241 Joaquin Avenue San Leandro CA 94577 510.991.0977	SCHNEIDER ELECTRIC NETSHELTER SX ANCHORAGE	Job No. 14109.01 & 19183
	LOW, MODERATE, AND HIGH SEISMIC REGIONS	Sheet No. SK9
	Signed by JH Date Aug 2019	

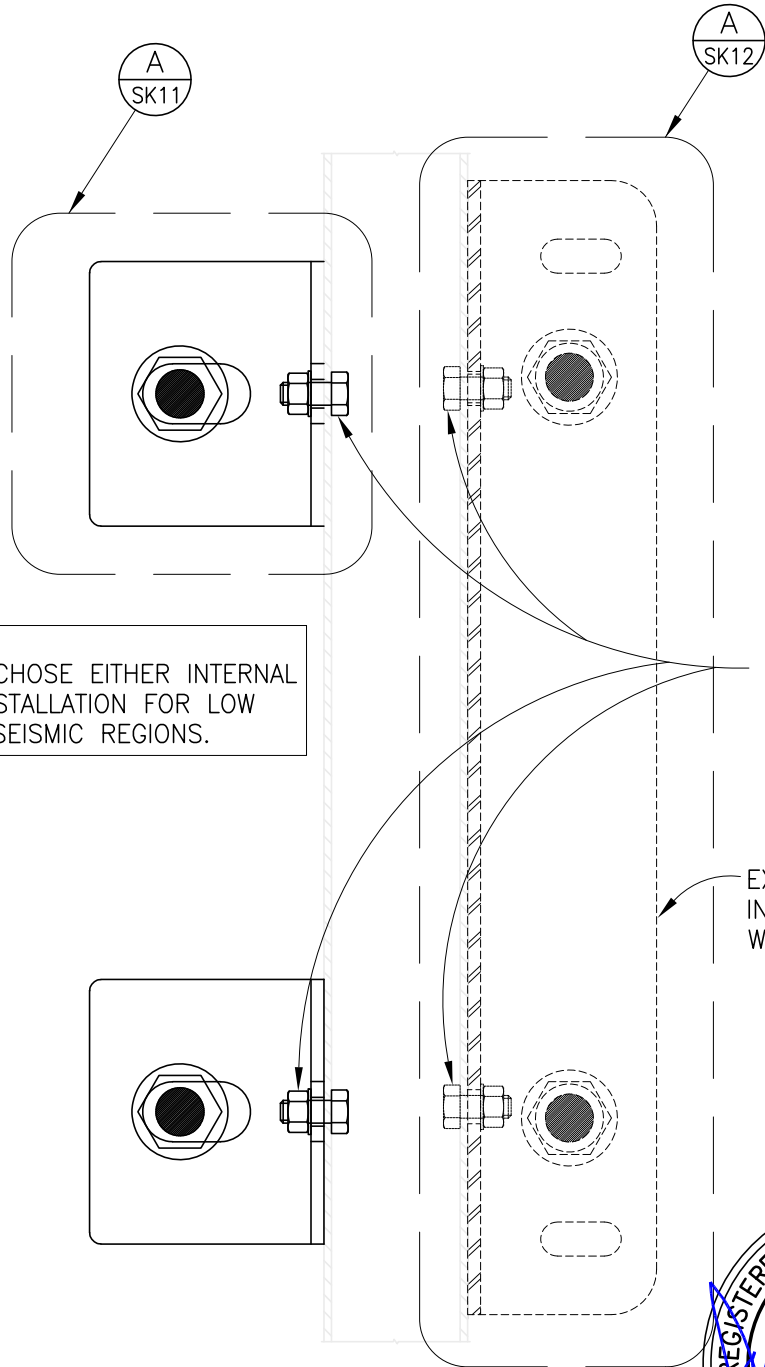

NOTE:
 CUSTOMER MAY CHOSE EITHER INTERNAL
 OR EXTERNAL INSTALLATION FOR LOW
 AND MODERATE SEISMIC REGIONS.

M6x12 HEX HEAD
 CAP SCREW GRADE
 10.9 STEEL ZINC
 PLATED ISO
 898-1, TYP.

EXTERIOR BRACKET
 INSTALLATION
 WHERE APPLICABLE

DETAIL **B**
 N.T.S. **SK10**



 Robinson Meier Juilly & Associates 241 Joaquin Avenue San Leandro CA 94577 510.991.0977	SCHNEIDER ELECTRIC NETSHELTER SX ANCHORAGE	Job No. 14109.01 & 19183
	LOW, MODERATE, AND HIGH SEISMIC REGIONS	Sheet No. (SK10)
	Signed by JH Date Aug 2019	

BRACKET SUPPLIED BY SCHNEIDER ELECTRIC (4 TOTAL) (0.118" THK PL ASTM A1008 SHS GRADE 41)

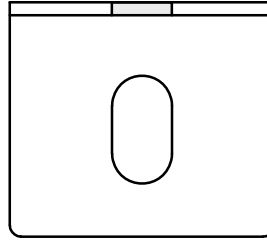
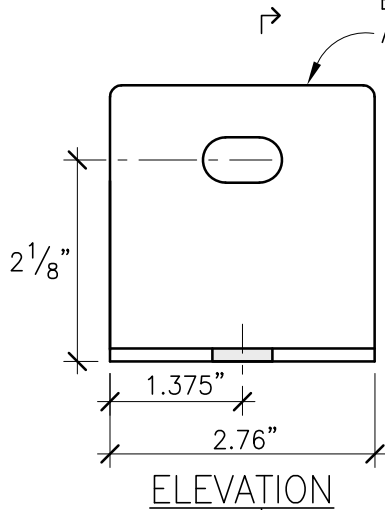

B
SK11

DETAIL
N.T.S.

A
SK11

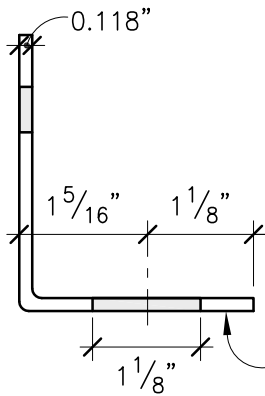

NOTE:
FOR EXACT BRACKET DIMENSION SEE APC NETSHELTER MANUFACTURE DRAWINGS.

ASTM A1008-13 SHS GRADE 41, TYP.

SECTION
DETAIL
N.T.S.

B
SK11



<p>Robinson Meier Jullily & Associates 241 Joaquin Avenue San Leandro CA 94577 510.991.0977</p>	<p>SCHNEIDER ELECTRIC NETSHELTER SX ANCHORAGE</p>	<p>Job No. 14109.01 & 19183</p>
	<p>LOW, MODERATE, AND HIGH SEISMIC REGIONS</p>	<p>Sheet No.</p>
	<p>Signed by JH Date Aug 2019</p>	<p>(SK11)</p>

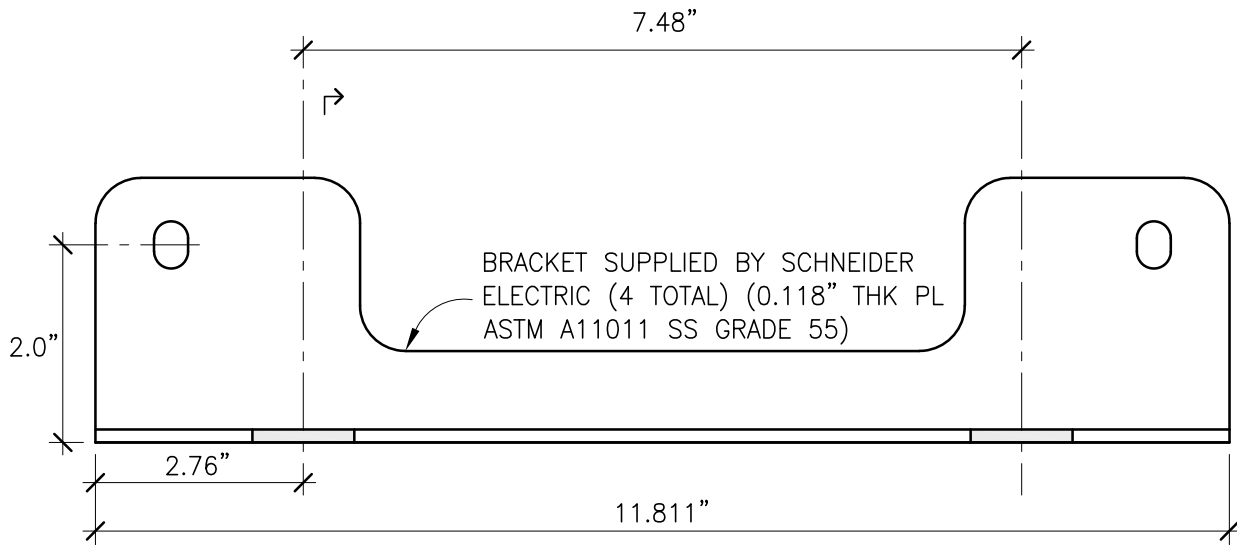

ELEVATION
DETAIL
 N.T.S. A
SK12

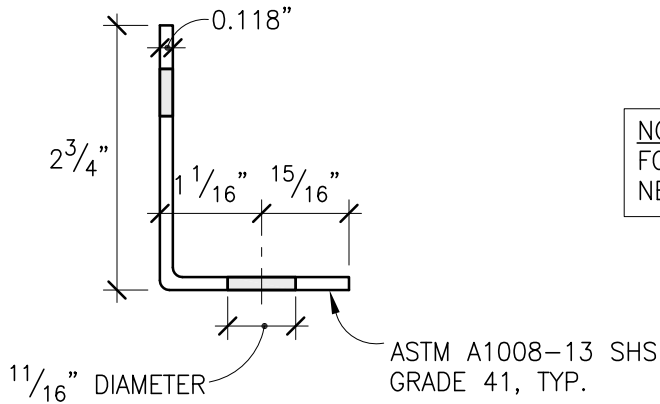

NOTE:
 FOR EXACT BRACKET DIMENSION SEE APC NETSHELTER MANUFACTURE DRAWINGS.

SECTION
DETAIL
 N.T.S. B
SK12



Robinson Meier Juilly & Associates Structural Engineers 241 Joaquin Avenue San Leandro CA 94577 510.991.0977	SCHNEIDER ELECTRIC NETSHELTER SX ANCHORAGE	Job No. 14109.01 & 19183
	LOW, MODERATE, AND HIGH SEISMIC REGIONS	Sheet No. SK12
	Signed by JH Date Aug 2019	

NOTE:
BOTH BRACKET ARE REQUIRED FOR SEISMIC REGIONS.

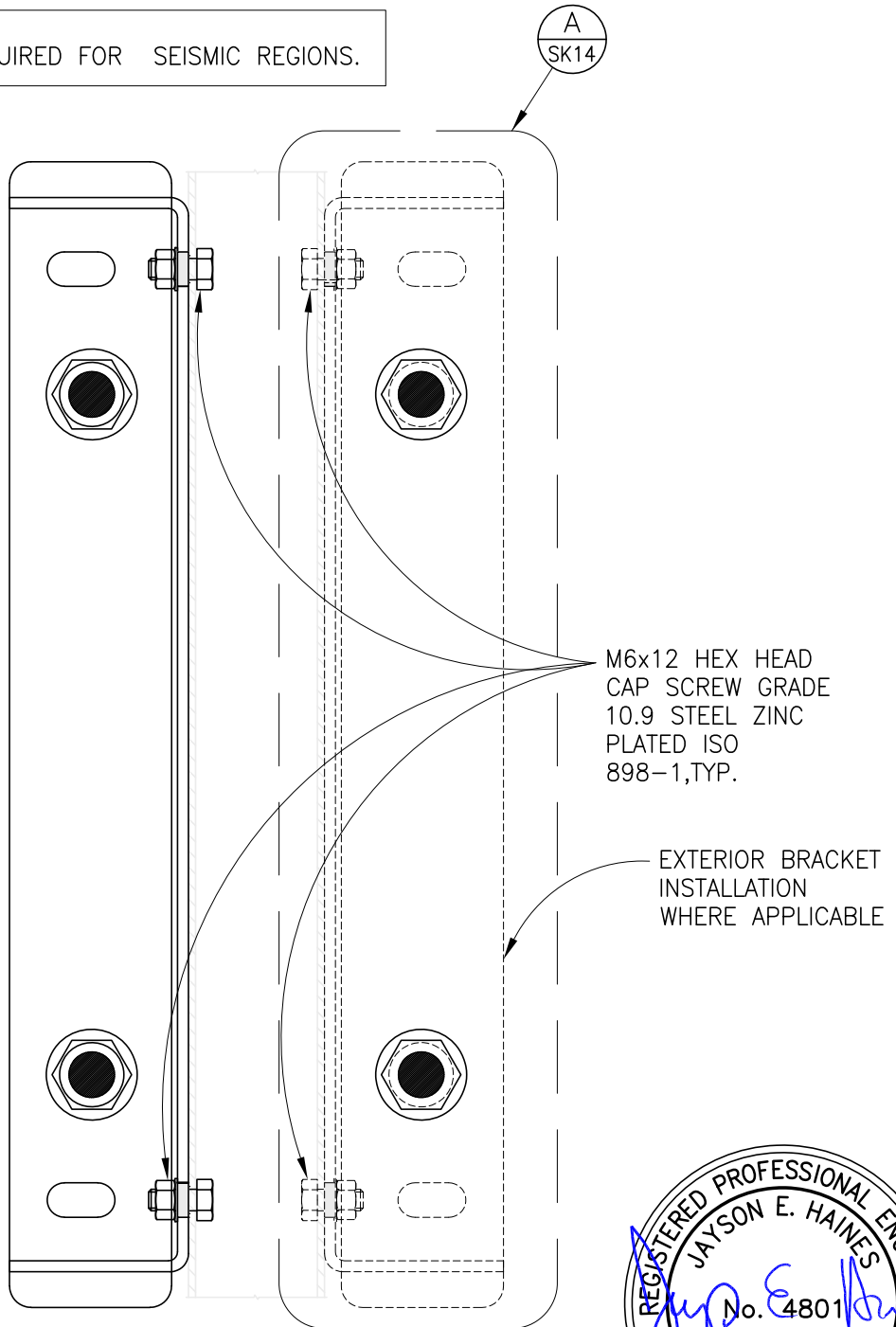

DETAIL A
N.T.S. SK13



 Robinson Meier Juilly & Associates Structural Engineers 241 Joaquin Avenue San Leandro CA 94577 510.991.0977	SCHNEIDER ELECTRIC NETSHELTER SX ANCHORAGE	Job No. 14109.01 & 19183
	LOW, MODERATE, AND HIGH SEISMIC REGIONS	Sheet No. SK13
	Signed by JH Date Aug 2019	

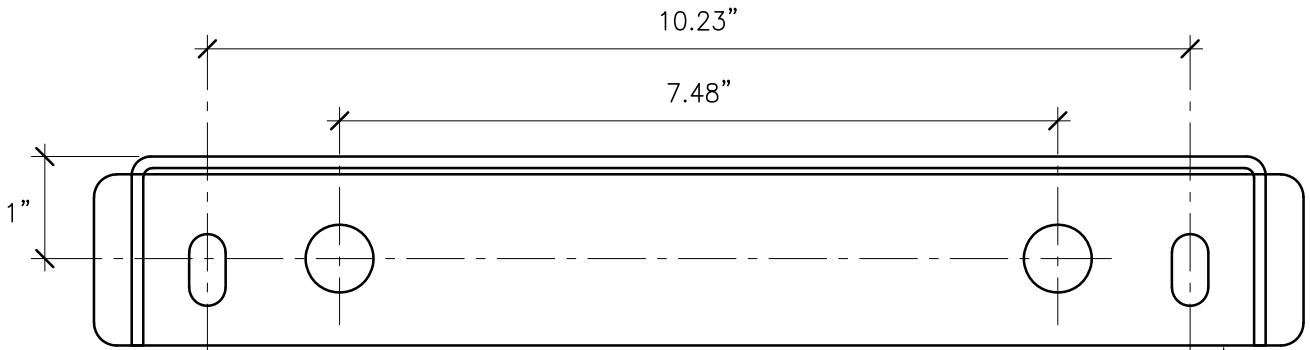

SEISMIC BRACKET PLAN

BRACKET SUPPLIED BY SCHNEIDER ELECTRIC (4 TOTAL) (0.135" THK PL A36 STEEL)

0.1182" GUSSET PL A36 STEEL

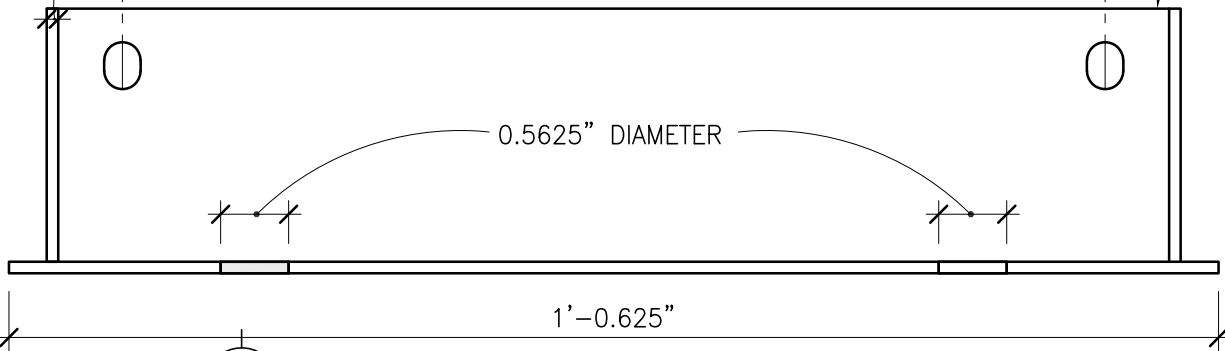

SEISMIC BRACKET ELEVATION

DETAIL

N.T.S.

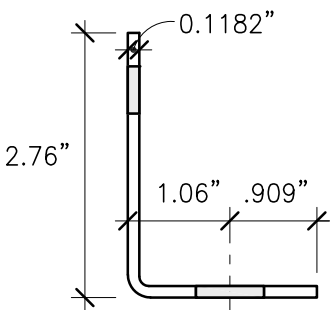

SECTION

N.T.S.



NOTE:
FOR EXACT BRACKET DIMENSION SEE APC NETSHELTER MANUFACTURE DRAWINGS.



 <p>Robinson Meier Juilly & Associates</p>	<p>Structural Engineers</p> <p>241 Joaquin Avenue San Leandro CA 94577 510.991.0977</p>

<p>SCHNEIDER ELECTRIC NETSHELTER SX ANCHORAGE</p>	
<p>LOW, MODERATE, AND HIGH SEISMIC REGIONS</p>	
<p>Signed by JH</p>	<p>Date Aug 2019</p>

<p>Job No. 14109.01 & 19183</p>
<p>Sheet No. </p>