

Acquisition card for U-Talk/Basic communications port

Installation and user manual

English

Français

APC[®]

by Schneider Electric



..... **i**

English version 1

Version française 9

5102922200-AC

990-5102922200AC

APC[®]

by Schneider Electric

Safety guidelines

The acquisition card can be installed and operated by all persons following the instructions given in this manual. However, if you encounter a problem, we recommend that you contact our after-sales support service.



It is imperative that the instructions be followed strictly.

Not adhering to these instructions may endanger personnel, result in damage and render the manufacturer's warranty void. All repair or maintenance operations must be carried out by our after-sales support personnel.

For more information on the **UPS**, please refer to its "installation and user manual".

Consignes de sécurité

L'installation et l'exploitation de la carte d'acquisition peuvent être réalisées par toute personne se conformant aux indications portées dans le présent manuel. Cependant, si vous rencontrez un problème, nous vous recommandons de consulter notre service après-vente.



Il est impératif de suivre les procédures décrites. Leur non respect peut entraîner des dangers pour les personnes, occasionner des dommages et annuler la garantie constructeur. Toute opération de dépannage ou de maintenance doit être effectuée par nos services.

Pour plus de détails concernant l'**ASI**, se référer au "manuel d'installation et d'utilisation" fourni avec l'appareil.

Sicherheitshinweise

Die Installierung und die Nutzung des Erfassungskarte können von jeder Person vorgenommen werden, die sich an die Anweisungen des vorliegenden Handbuchs hält. Doch, sollte es Probleme geben, setzen Sie sich bitte mit dem APC by Schneider Electric Kundendienst in Verbindung.



Es ist wichtig, die Einzelschritte zu befolgen. Ein Nichtbeachten kann zu Gefährdung von Personen, Schäden an der Anlage, sowie dem Verlust der Herstellergarantie führen. Arbeiten, die das Öffnen der Geräte notwendig machen, dürfen nur von Elektro-Fachpersonal durchgeführt werden.

Für weitergehende Informationen zur **USV**-Anlage möchten wir auf die Bedienungs- und Installationsanleitung **USV** hinweisen.

Consegne di sicurezza

L'installazione e la gestione della scheda di acquisizione possono essere realizzate da qualsiasi operatore che si conformi alle indicazioni riportate nel presente manuale. Eppure, se incontrate difficoltà, noi vi raccomandiamo di consultare il nostro servizio assistenza dopo vendita.



E' imperativo seguire rigorosamente le procedure descritte. Se non si rispettano queste procedure puo' essere pericoloso per le persone, cagionare danni ed annullare la garanzia del costruttore. Tutte le operazioni di riparazione o di manutenzione devono essere effettuate dai nostri servizi.

Per maggiori dettagli concernente l'**UPS**, riferirsi al "libretto d'installazione e d'istruzioni" fornito con questo apparecchio.

Consignas de seguridad

Cualquier persona que se conforme a las indicaciones establecidas en el presente manual podrá realizar la instalación y la explotación de la tarjeta de adquisición. Si ocurre un problema al poner en práctica los procedimientos descritos en este manual, le recomendamos consultar nuestro servicio de postventa.



Es imperativo respetar rigurosamente los procedimientos descritos. No respetar estos procedimientos puede acarrear peligro para las vidas humanas, ocasionar perjuicios y anular la garantía del fabricante. Toda operación de reparación o mantenimiento debe ser efectuada por nuestros servicios.

Para mayores detalles sobre el **SAI**, consultar el "manual de instalación e instrucciones" suministrado con el aparato.

Regras de segurança

A instalação e a exploração da carta de aquisição podem ser realizadas por qualquer pessoa que cumpra as indicações mencionadas no presente manual. Caso algum problema se apresente, recomendamos consultar nosso serviço após venda.



É imperativo que os procedimentos descritos sejam seguidos rigorosamente. O desrespeito dos mesmos procedimentos pode ocasionar perigos para as pessoas, causar avarias no aparelho, e anular a garantia do fabricante. Toda operação de conserto ou de manutenção deve ser efetuada por nossos serviços.

Para mais detalhes concernentes ao aparelho, referir-se ao "manual de instalação e de utilização" fornecido com o aparelho.

Veiligheidsvoorschriften

De verwervingskaart kan worden geïnstalleerd en bediend door elke persoon die de instructies in deze handleiding strikt opvolgt. Indien u een probleem, kunt u het beste contact opnemen met onze service afdeling.



Het is noodzakelijk dat u de instructies strikt opvolgt. Het niet opvolgen van deze instructies kan het personeel in gevaar brengen, resulteren in schade en de garantie komt te vervallen. Alle reparatie- en onderhoudswerkzaamheden moeten uitgevoerd worden door ons service personeel.

Voor meer informatie betreffende de UPS, zie de "installatie- en gebruikershandleiding".

Säkerhetsföreskrifter

Innsamlingskortet kan installeras och användas av alla som följer de instruktioner som ges i den här manualen. Om Du stöter på problem, rekommenderar vi att Du kontaktar vår serviceverkstad.



Det är mycket viktigt att Du noggrant följer instruktionerna i denna bruksanvisning. Om instruktionerna inte följs kan materialet skadas och bli farligt att använda. Dessutom upphör tillverkarens garanti att gälla. Reparationer och underhåll får endast utföras av kvalificerad fackman.

Mer utförlig information om materialet hittar Du i bruksanvisningen för installation och användning.

Sikkerhedsforskrifter

Opsamlingskortet kan installeres og bruges af alle personer, der følger instruktionerne i denne manual. Pas på ! Skulle De støde på problemer, til trods for at De har fulgt anvisningerne i vores instruktionsbog, bør De henvende Dem til vores kundeservice.



Det er absolut nødvendigt at følge anvisningerne i instruktionsbogen. Hvis De ikke overholder dem, risikerer De at udsætte Deres personal for fare, at apparatet bliver beskadiget, og at garantien i så fald bortfalder. Reparation og vedligeholdelse bør kun foretages af vore teknikere.

Ønsker De mere detaljerede oplysninger vedrørende apparatet, kan De finde dem i vores instruktionsbog, som bliver leveret sammen med apparatet.

Turvallisuusohjeet

Tunnistuspiirilevyn voi asentaa ja sitä voivat käyttää kaikki henkilöt tämän käyttöohjeen ohjeiden mukaisesti. Jos törmäätte ongelmiin seurattessanne käsikirjassa kuvattuja toimintaohjeita, suosittelemme huoltopalvelumme puoleen kääntymistä.



On ehdottoman tärkeää seurata tarkkaan käsikirjassa kuvattuja toimintaohjeita. Laiminlyönti saattaa aiheuttaa henkilölle vaaratilanteen, laite voi vaurioitua ja rakentajan takuu peruuntua. Kaikki korjaus- ja huoltotoimet on suoritettava oman henkilökuntamme kautta.

Laite mukana tulevasta "asentamista ja käyttöä käsittlevästä käsikirjasta" löydätte lisätietoja laitteesta.

Sikkerhedsforskrifter

Innsamlingskortet kan installeres og brukes av alle personer som følger instruksjonene i denne veiledningen. Dersom det oppstår problemer, bør du ta kontakt med vår serviceavdeling.



Det er ytterst viktig at du følger fremgangsmåten som er beskrevet i håndboken, til punkt og prikke. Operasjoner utført i strid med disse retningslinjene kan forårsake personskader eller skader på apparatet og annullere fabrikantens garanti. Alle reparasjons- og vedlikeholdsinngrep må utføres av vårt servicepersonale.

Trenger du flere opplysninger om apparatet, kan du slå opp i "Håndbok for installering og bruk" som følger med apparatet.

Contents

Presentation

Contents of package	2
Storage	2
Recycling of packing materials	2
Function	3
Overall view	3

Connection to a UPS

4

Installation

5

Operation

6

Troubleshooting

Operating anomalies	7
Cable replacement	7

Appendices

Glossary	8
Index	8

All APC by Schneider Electric products are protected by patents. They implement original technology which is not available to other competitors of APC by Schneider Electric.

To take evolving standards and technology into account, the technical characteristics contained in this document are not binding unless confirmed by APC by Schneider Electric.

This document may be reproduced only with the consent of APC by Schneider Electric. Authorised copies must be marked "Installation and user manual of the APC by Schneider Electric acquisition card for U-Talk/Basic communications port n° 5102922200".

Presentation

Contents of package

This optional equipment is made up of the following components (see figure 1):

- ▶ one acquisition card,
- ▶ one DB9/DB9 RS232 serial communications cable,
- ▶ one installation and user manual for the acquisition card (this document).

Storage

If the card is stored prior to installation, it should remain in the original packing in a dry place. The storage temperature range is -40°C to $+70^{\circ}\text{C}$.

Recycling of packing materials

Packing materials must be disposed of in compliance with applicable laws and regulations.

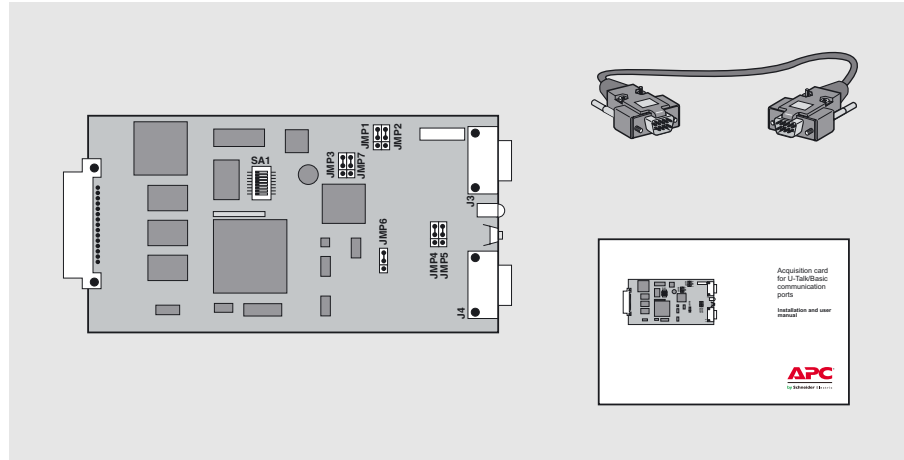

Fig. 1

Function

The acquisition card is an optional part of the **MultiSlot** module (see the installation and user manual for the **MultiSlot** module, ref. 5102919700).

The card acts as the interface between the I2C bus of the **MultiSlot** module and the supervised UPS (Uninterruptible Power Supply).

Using the APC by Schneider Electric proprietary protocol (U-Talk) it acquires measurements, status information and alarms from the UPS to which it is connected and transmits the data to the I2C bus of the **MultiSlot** module in which it is installed.

Overall view

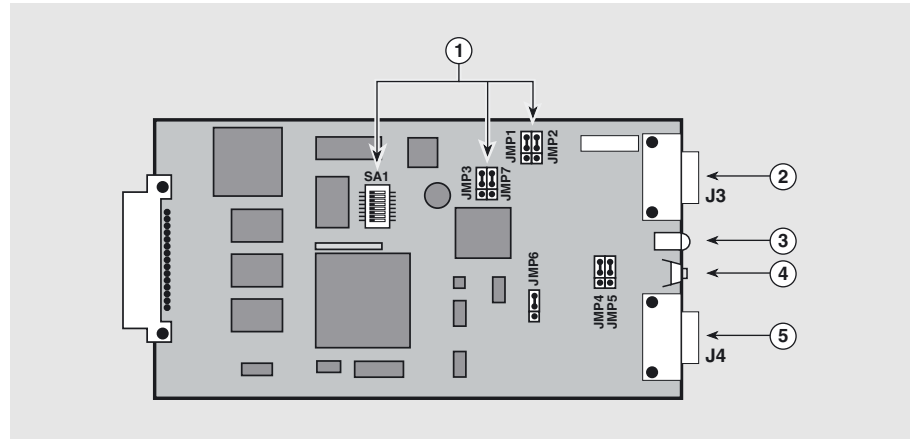

Fig. 2: Acquisition card for the MultiSlot module.

Key:

- ① jumpers and DIP switches for acquisition card settings,
- ② UPS U-Talk/Basic acquisition port,
- ③ green light indicating the operation of the acquisition card,
- ④ reset button,
- ⑤ unused port,

Jumpers JMP4, JMP5 and JMP6 are not used for this application.

Connection to a UPS

The default card settings are for this type of connection. Figure 3 shows the corresponding positions of the jumpers and DIP switches. Before changing any of the DIP switches on the SA1 block, the plastic protection sheet must be removed.

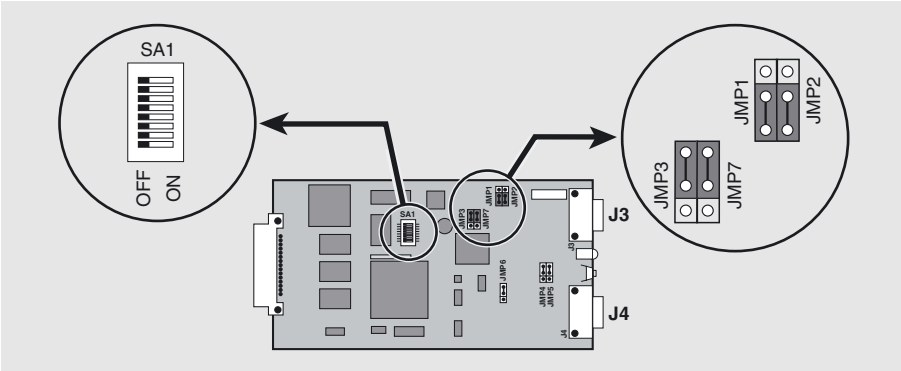

Fig. 3

Installation

The acquisition card may be installed in any of the four slots in the **MultiSlot** module. No particular order is required (see the manual of the **MultiSlot** module). Only the DB9 J3 connector on the acquisition card may be used for connection. Connector J4 is reserved for future applications.

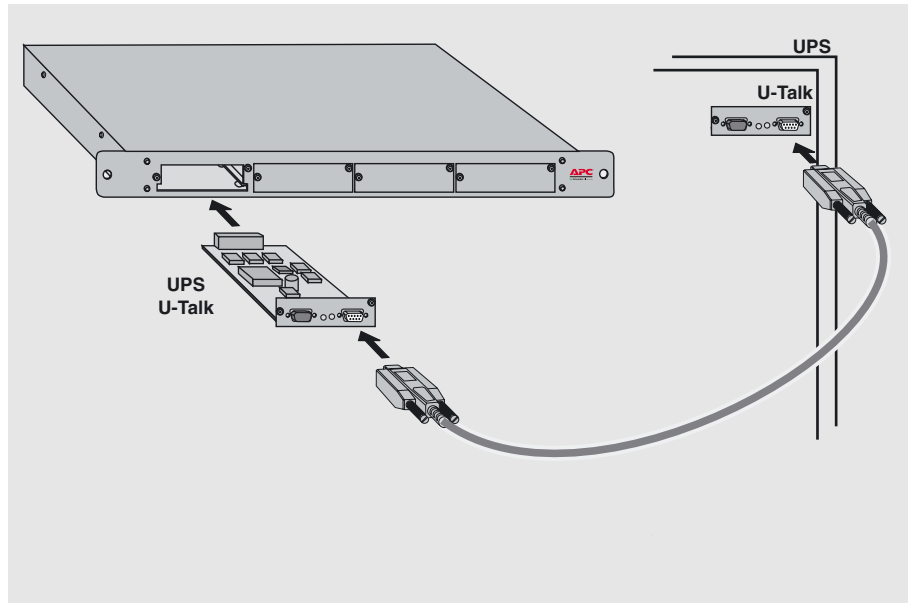

Fig. 4

Operation

When the acquisition card is installed in the **MultiSlot** module, the following occurs:

- ▶ the green light ③ on the acquisition card flashes once every second during the start-up phase,
- ▶ if communications cards are connected to the module, the green light ③ flashes more rapidly and irregularly during initialization of the dialogue on the I2C bus of the **MultiSlot** module,
- ▶ Once dialogue with the UPS has been initialized, the green light ③ flashes when data is exchanged between the UPS and the acquisition card,

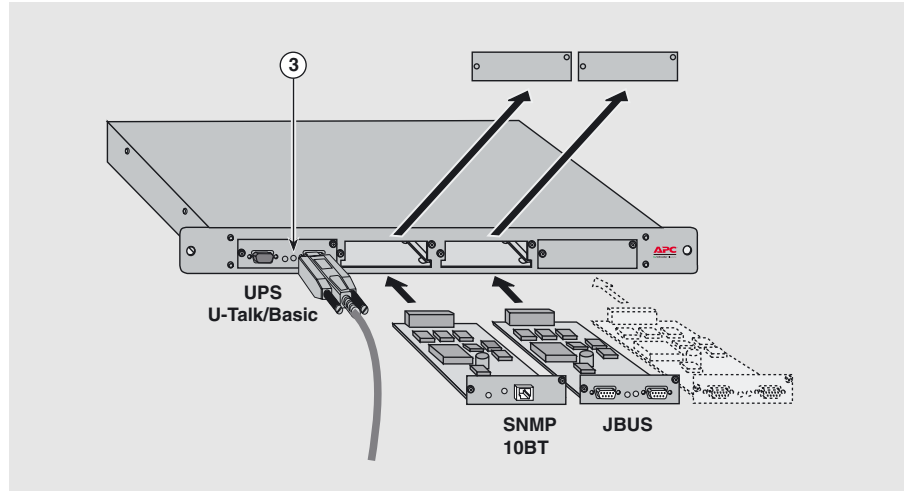

Fig. 5

Troubleshooting

Operating anomalies

AC-power problem

The green light ③ on the acquisition card remains off:

- ▶ check the supply of power to the **MultiSlot** module,
- ▶ check that the acquisition card is correctly installed (fully inserted) in the module,
- ▶ press the reset button ④ on the acquisition card.

Start-up problem

The green light ③ on the acquisition card remains on: press the reset button ④ on the acquisition card.

Cable replacement

If the communications cable supplied with the acquisition card is lost or damaged, a cable wired as indicated in figure 7 may be used.

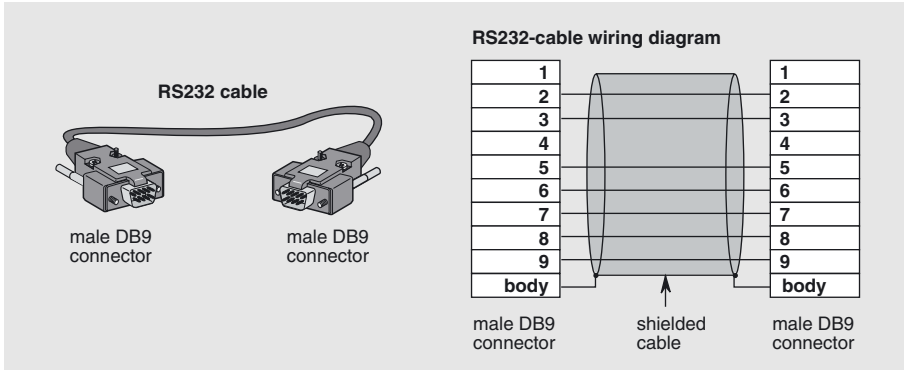

Fig. 6

If the problem continues, contact our after-sales support department.

Appendices

Glossary

Basic: information exchange protocol using dry contacts,

I2C: multi-point and multi-master communications protocol and bus,

JBus: master-slave communications protocol using a point-to-point (RS232) or multi-point (RS485) serial link,

SNMP: Ethernet communications protocol,

UPS: Uninterruptible Power Supply,

U-Talk: point-to-point ASCII communications protocol using an RS232 serial link. U-Talk is the APC by Schneider Electric proprietary protocol.

Index

UPS (connection)	4-5
Warnings (⚠)	i
Communications cable	2, 7
Contents of package	2
Settings	4
Troubleshooting	7