

# Fundamental Principles of Generators for Information Technology

## White Paper 93

Revision 1

by Robert Wolfgang

### > Executive summary

Every information technology (IT) professional that is responsible for the operation of computing equipment needs to ensure their data center or network room is prepared for extended utility power outages. Understanding the basic functions and concepts of standby generator systems helps provide a solid foundation allowing IT professionals to successfully specify, install, and operate critical facilities. This paper is an introduction to standby generators and subsystems that power a facility's critical electrical loads when the utility cannot.

### Contents

*Click on a section to jump to it*

The prime mover: Internal combustion engine	2
The alternator: The electrical generation component	5
The governor: AC output frequency and regulation	7
Voltage regulation	7
Switchgear & distribution	8
Multiple or parallel redundant generator systems	9
Overall system and compatibility design	10
Conclusion	10
Resources	11

## Introduction

A standby generator system is composed of two basic subsystems: (1) the generator, which is made up of the prime mover, the alternator, and the governor, and (2) the distribution system, which is made up of the automatic transfer switch (ATS) and associated switchgear and distribution. **Figure 1** illustrates a typical standby generator. This paper explains these major subsystems and their basic function, however, it is an introductory paper from a suite of related Schneider Electric papers on more advanced generator system topics, and provides references for readers interested in a more complete treatment of the subject.



**Figure 1**

*Standby generator*

 [Link to resource](#)  
**White Paper 90**  
*Allocating Data Center Energy  
 Costs and Carbon to IT Users*

When investing in a generator system one should be aware of the technological advantages afforded by today's systems, and the significant advances in reliability and functionality that have been made over the past 10-15 years. Older generator systems can often be retrofit to meet current requirements. See White Paper 90, *Essential Generator System Requirements for Next Generation Data Centers* for a further discussion on essential generator system requirements for today's mission critical facilities.

## The prime mover: Internal combustion engine

What is internal combustion? Chances are that an internal combustion engine powers the car you drive today. The internal combustion engine is the well-respected workhorse of the later half of the 20th century, and has carried this role into the new millennium. In basic terms an internal combustion engine converts its fuel source into mechanical motion via its internal moving parts. As outside air mixes with the fuel inside the engine these moving parts ignite the air / fuel mixture to create a controlled internal explosion (combustion) within cavities known as cylinders. Although there are numerous variations of the internal combustion engine, the most commonly used for standby generator systems is the 4-stroke engine. It is referred to as a 4-stroke because of the four distinct stages that occur in the combustion cycle. These stages include intake of the air / fuel mixture, compression of that mixture,

combustion or explosion, and exhaust. When referring to generators the engine is generally referred as the prime mover. The following describes the core attributes associated with the prime mover.

## Fuel

There are four main fuels used in internal combustion engines. These include diesel, natural gas, liquid petroleum (LP), and gasoline. The selection of a fuel type depends on variables such as storage, cost, and accessibility.

## Exhaust, emissions, and noise

The generator system exhaust is a significant issue when it comes to air and noise pollution. While the concept of attenuating noise and ducting exhaust air is straightforward, the environmental and regulatory issues are not. EGSA (Electrical Generating Systems Association) is a worldwide organization that offers a wealth of information about emissions and other standby generator considerations. Environmental laws, building permits, and duration of generator use vary considerably by locale. For example, the United States Federal Environmental Protection Agency (EPA) has delegated to each state the jurisdictional authority and discretion on how to achieve air quality goals established on the national level. Other countries have similar regulatory bodies that set limits on generator emissions. For instance, Defra (Department for Environment Food and Rural Affairs) sets policies for environmental protection in the United Kingdom. And in India the Ministry of Environment and Forests (MoEF) plays this role. If the facility is located in a stringent area, the generator system declarations on emissions may be required when applying for permits. Industry professionals are usually experienced with the approval process in the locations they serve.

Another matter subject to the acceptance of jurisdictional authorities is that of noise pollution. Local ordinances on noise pollution typically put it in context with the highest recordable background noise observable in a 24-hour period. Exhaust mufflers are generally categorized as industrial, residential, or critical. Critical offers the highest level of sound reduction. To spare the expense of a retrofit design, one should consider the noise rating of the system prior to purchase and have these numbers qualified by the zoning authority in the planning stages. Mechanical vibration also contributes to the overall noise level and the perception of noise for occupants in the surrounding area. Mounting and isolation techniques exist to minimize this concern.

A third matter that is important to discuss is that of aesthetics, since generators may be subject to the acceptance of local municipalities. Some municipalities have requirements in terms of placement of the generator, including requiring that it be housed within concrete / block walls that match the main building's appearance. This keeps the generator from being noticed and keeps it aesthetically neutral to the surrounding neighborhood.

## Combustion air intake

It is important that provisions for cool, clean airflow to the engine be incorporated into the room's design. It is also suggested that ample cool, fresh air be brought in for the comfort of the personnel. Often this requires large vents and possibly supplemental fans. Precautions should also be made to prevent rain, snow, and debris introduction into the system.

## Cooling

The majority of prime movers for generator applications are cooled with a radiator cooling system much like the cooling system in an automobile. A fan is used to move sufficient air

over the radiator to maintain moderate engine temperature. The waste heat is drawn off the radiator to the outside, with ductwork of the same cross-sectional area as the radiator face. The intake air opening (louvers into the room) is typically 25-50% larger than this ductwork. Rigorous maintenance of the cooling system is needed for reliable operation. Coolant hoses, coolant level, water pump operation, and antifreeze protection must be diligently reviewed for acceptable performance.

## Lubrication

Modern 4-stroke engines utilize full-flow filter systems, which pump the lube oil through externally mounted filters to prevent harmful particles and contaminants from damaging the moving parts or bearings. Make-up oil reservoirs are used to maintain proper oil level, and external oil coolers assist in preventing lubrication breakdown due to high temperatures.

## Filters: air and fuel

Air and fuel are critical elements for the reliable operation of the prime mover. It is essential that a proper maintenance schedule be followed. A system that includes dual redundant fuel lines and filters is a significant benefit in mission-critical applications where long runtime must be supported. This is because fuel lines and filters can be isolated and changed while the engine remains running. Not having spare parts for filters and other "consumables" can result in downtime.

Proactive monitoring of these filters is done with differential pressure indicators. They show the pressure difference across a filter or between two fuel lines during engine operation. When applied to air filters, these proactive monitoring devices are known as air restrict indicators. These provide a visual indication of the need to replace a dry-type intake air filter while the generator engine runs.

## Starter motor

The starting system is one of the most critical to the successful use of the generator. UPS systems with a few minutes of battery runtime are often present for mission-critical loads, so rapid startup is important. The minimum time to detect the power problem, start the prime mover, establish stable output frequency and voltage, and connect to loads is usually at least 10-15 seconds. However, many systems in use today do not reliably perform to this very quick deployment due to such factors as uncharged or stolen batteries. Other factors include improper maintenance and human error. Conscientious maintenance and design is absolutely critical to achieving a respectable success rate for generator system startups.

The majority of generator systems use a battery-operated starter motor, as in automotive applications, although pneumatic or hydraulic alternatives are sometimes found on the heaviest prime movers. The critical element in the conventional starter is clearly the battery system. For example, the battery-charging alternator present on some engines does nothing to prevent battery discharge during the unused periods. Providing a separate, automatic charging system with remote alarm is considered "best practice." It is also essential to keep the battery warm and corrosion-free.

Battery warming is accomplished with a heater that maintains lead acid battery electrolyte temperature. In cold climates, this will considerably increase the engine cranking current available to the starter motor. Batteries are rated in CCA (Cold Cranking Amperes), which specifies the amperes available for 30 seconds at 0°F (-17.8°C). At temperatures below 0°F (-17.8°C) and above 80°F (26.7°C), the reliability is very poor.

Engine block heaters also contribute to the startup success rate by reducing the frictional forces that the starter motor must work against when energized. Numerous studies have found startup failures to be the leading cause of generator system failures.

## The alternator: The electrical generation component

The function of the alternator is to convert mechanical energy from the prime mover into alternating current. This is similar to the alternator in an automobile, however in an automobile it is usually driven by a belt, whereas in a generator it is driven by the main drive shaft of the prime mover. A very basic alternator can be made from a loop of metal wire and a magnet. Electricity is produced when the loop of wire is moved through the magnetic field produced by the positive and negative poles of the magnet. Alternatively the magnetic field could move while the wire remains stationary. An alternator of this type would obviously produce a very small amount of electricity but is based on the same electrical principles as large alternators used in generators. Through the years, certain characteristics of alternator components have been improved to increase the efficiency, capacity and reliability of the alternator. Each of these characteristics is explained below. **Figure 2** illustrates the main components of a typical alternator found in a generator system.

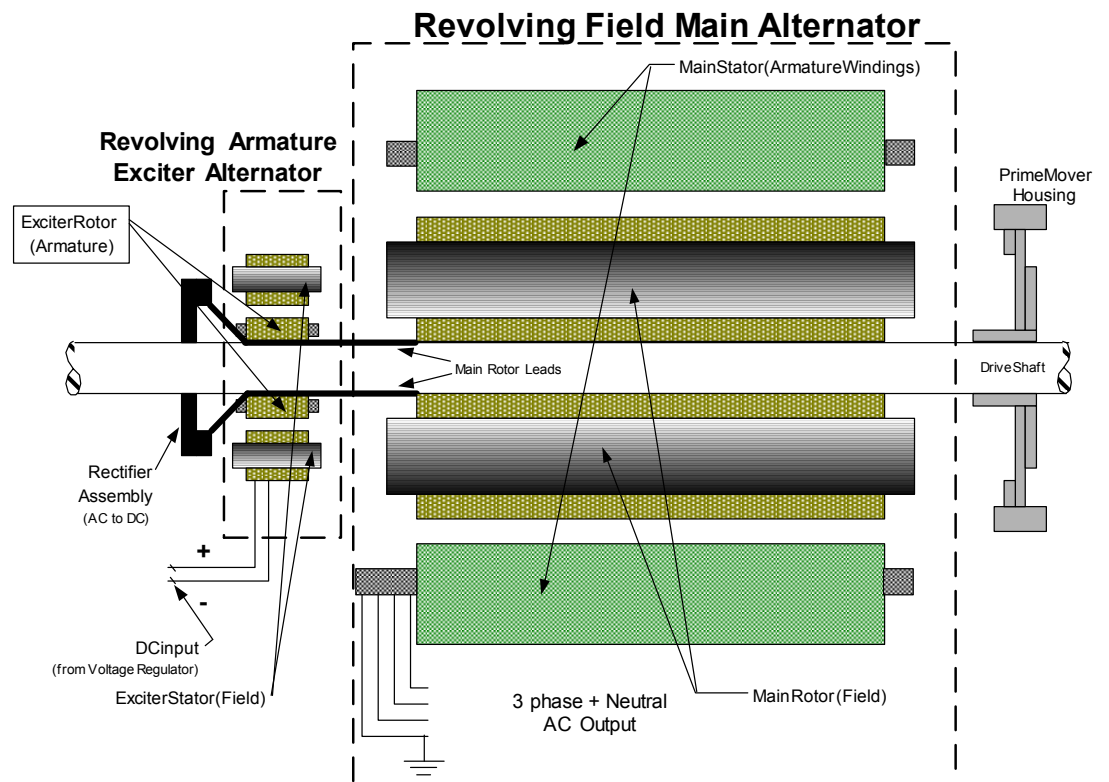

**Figure 2**

*Cross sectional view:  
self-excited, externally  
regulated, brushless  
alternator*

### Brushless

The brushless designation refers to the fact that this design requires no contacts placed against any revolving parts to transfer electrical energy to or from the components. Brushes in motors and very small generators may still be an acceptable design, but predictably the brushes wear out with use, and are impossible to inspect in a proactive manner. A large generator design that relies on brushes is not up to the reliability standards needed for mission-critical operation.

## Self-excited

In the example above a magnet was used to generate a magnetic field. For large alternators a much stronger magnetic field is required to generate large amounts of electricity. Similarly, a junkyard wouldn't be able to move large pieces of metal with a simple magnet; instead it uses an electromagnet hanging from a crane. An electromagnet is a magnet that is powered by electricity and in the case of modern alternators the magnet is "self-excited". Self-excited means the electricity used to create the electromagnetic field is created within the alternator itself thereby allowing the alternator to produce large amounts of electricity with no other energy other than that provided by the prime mover.

## Main stator or armature windings

The main stator or armature windings are the stationary coils of wire where the electricity for the critical loads is induced. The characteristics of the alternating current produced are related to the quantity and geometry of the coil windings. A large variety of configurations are available to deliver combinations of ampacity and voltage requirements.

Three phase windings are three separate coils arranged 120 degrees apart on the circumference of rotation. When the alternator's magnetic field has just one pair of North / South poles, one cycle of alternating current per phase is created per rotation of the prime mover. In other words, to produce 60 Hz AC, the prime mover needs to spin the alternator at 3600 RPM (revolutions per minute). This is a moderately high RPM for diesel generator systems, which will experience about twice the "wear and tear" as an engine running at 1800 RPM. By designing the alternator's magnetic field with four poles, the prime mover's RPM can be governed to 1800 RPM to yield the 60 Hz output. Generator systems with even lower RPM designs that incorporate 6 pole or 8 pole alternators (1200 RPM and 900 RPM respectively) are also available.

## Grounding

Grounding of the generator system and bonding of the neutral is a vital detail. It is imperative for both fault clearing and power quality that the method of grounding be consistent with the electrical code of the applicable region. For example, the United States uses the National Electrical Code (NEC) Article 250 Ref. 4 (or other additional standard for the jurisdiction).

Grounding is perhaps the most misunderstood and misapplied wiring aspect of facilities of all sizes. Applicable information is contained in IEEE<sup>1</sup> Standard 446-1995, IEEE Recommended Practice for Emergency and Standby Power Systems for Industrial and Commercial Applications (Orange Book). When powering sensitive electronic loads, serious consideration should also be given to the recommendations of the IEEE Standard 1100-1999, IEEE Recommended Practice for Powering and Grounding Electronic Equipment (Emerald Book).

## Temperature rating

Temperature rating of the alternator windings is another important specification, particularly for applications that could involve excessive environmental conditions of altitude, ambient temperature, or ventilation.

---

<sup>1</sup> IEEE (Institute of Electrical and Electronics Engineers) is a leading authority in wide range of technical areas including electric power. It is a non-profit, technical professional association of more than 360,000 individual members in approximately 175 countries. [www.ieee.org](http://www.ieee.org)

Over-sizing with a larger generator is sometimes used to hold down winding temperatures. Alternately, special insulation is available to withstand higher temperatures. The specific operating environment may have operational challenges and harsh conditions due to humidity, temperature, fungus, vermin, etc. Special designs and insulation for environmental threats are available, which assist in keeping the windings dry and avoiding deterioration of the insulation.

## The governor: AC output frequency and regulation

The governor maintains constant RPM of the prime mover under a variety of conditions by adjusting the fuel that feeds the prime mover. A stable AC frequency is required and is directly proportional to the accuracy and response time of the governor. This item is a key component in determining the AC output power quality.

Frequency variation and its impact on power quality is not a problem that users must contend with when connected to a stable utility grid. However, sensitive electronics are vulnerable to disruption due to abrupt changes in frequency under the influence of generator power. The generator's capability to produce a constant frequency is directly proportional to the RPM speed of the prime mover which is controlled by the governor. Many system designs exist, from simple spring-types to complex hydraulics and electronic systems that dynamically adjust the fuel throttle to keep the engine at constant RPM. Simply adding or removing loads, or cycling those loads on and off, creates conditions to which the governor must respond.

An isochronous (same speed) governor design maintains constant speed regardless of load level. Small variations on the speed of the prime mover still occur and their extent is a measure of the governor's stability. Today governor technology exists to maintain frequency regulation to within  $\pm 0.25\%$  with response times to changing loads on the order of 1 to 3 seconds. Today's electronic solid-state designs deliver high reliability and the needed frequency regulation for sensitive loads.

When two or more generators are paralleled for capacity or redundancy they must all be governed at the same speed using either the utility or another generator as the primary frequency reference. This is because if the two sources are out of synch, one of them will carry a larger fraction of the load, which will result in a needed correction.

Sophisticated electronic governor systems for paralleling have recently been developed that provide superior coordination and frequency stability under a variety of conditions. These advances are a welcome enhancement to the high availability requirements of today's data centers, due to their reliability, reduced maintenance, and coordination efforts.

The generator's fuel type, as well as the magnitude of potential step-load changes, will influence the selection of the governor. Because both these factors contribute to the accuracy and stability of the prime mover's speed, they must be considered in the overall design.

## Voltage regulation

The basic function of a voltage regulator is simply to control the voltage produced at the output of the alternator. The operation of the voltage regulator is vital to critical loads dependent on computer grade power. The goal is to configure a system with an appropriate response time to minimize sags and surges that occur as the load changes. Another issue to be aware of is the behavior of the regulator when subjected to non-linear loads such as older switch-mode power supplies. Non-linear loads draw current in a manner that is inconsistent with the voltage waveform, while resistive loads (like a light bulb) draw current in synch with the voltage waveform. Non-linear loads can interact negatively with a generator system thereby jeopardizing the availability of the critical load during standby operation.

EGSA 101E Section 5 defines the parameter of voltage regulation to be the “difference between the steady state no-load and full load voltage expressed as a percentage of the full load voltage.” There are three aspects of the alternator that determine voltage: the strength of the magnetic field, the speed at which the magnetic field is cut, and the number of windings (turns) in the coil. The latter two influences are constant in this discussion, which means that the voltage regulation is a function of altering the magnetic field to achieve the desired result.

Many technologies exist for monitoring the output voltage to provide the most appropriate power quality for data center use. Regardless of the regulator design, one should engineer for the “worst case scenario” that still yields less than the maximum tolerable variation in voltage. The factors that may contribute to worst-case situations include low voltage due to excess winding temperature or a high percentage of non-linear loads. Today’s data centers contain very few non-linear loads due to the prevalence of power factor corrected (PFC) power supplies. However, if the generator is to be used as back up for other building systems, non-linear loads should be identified to ensure proper generator system selection.

## Switchgear and distribution

The distribution of the generator’s output to the critical loads is another area that is very important to the system design. The IEEE Emerald Book (IEEE Standard 1100-1999) is recognized as a leading authority on powering sensitive equipment. Their recommended practice is to design the system per the IEEE Orange Book (IEEE Standard 446-1995). The IEEE Orange Book provides guidelines on automatic systems that monitor the utility source and initiate engine starting and transfer of the load to generator as soon as it is available and stable. This includes re-transfer of the load to utility when normal conditions are restored. Typically, all these functions are incorporated into a system known as an automatic transfer switch (ATS). Other common features include automatic generator test scheduling and a very important cool-down cycle for the generator after the utility is restored. Traditionally this hardware is sourced from a variety of vendors, including the generator manufacturers, distribution switchgear manufacturers, and specialists in ATS design. However, pre-engineered systems exist today that avoid the pitfalls of customized solutions including high total cost of ownership (TCO) and complexity. **Figure 3** illustrates the position of the ATS in the building's electrical distribution.

**Figure 3**

*Standby generator system with automatic transfer switch*

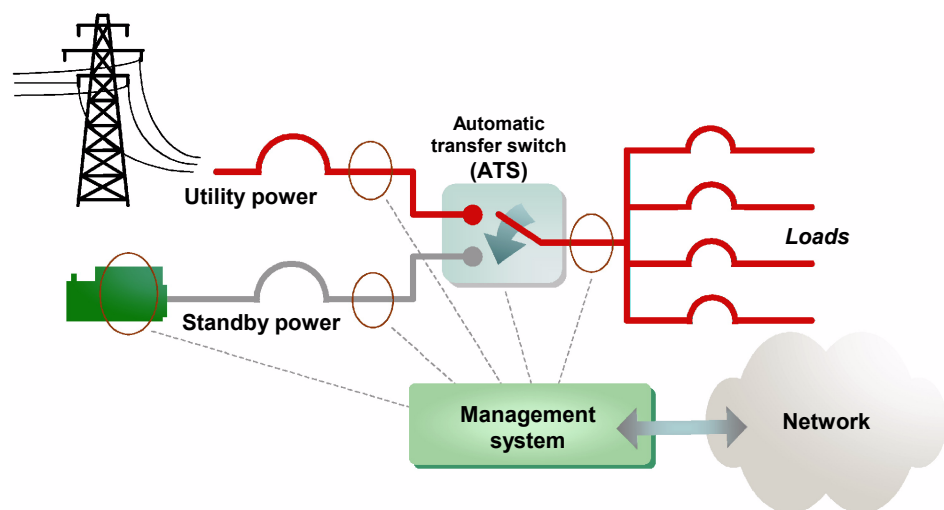

The system design must also take into account appropriate over-current protection. The contacts of the switching mechanism must be able to withstand inrush currents without welding. It is also important that the switch avoids overheating at full load current and is able to deliver appropriate short circuit current (current required to trip overcurrent protection



devices such as circuit breakers). Different switching schemes exist for re-transfer back to utility, known as open transition and closed transition. Open transition means that the load is first disconnected from utility before being connected to the generator. Closed transition means that the load is first connected to the generator and then disconnected from utility. This means that for a short period of time both the utility and generator are connected simultaneously. The closed transition type is more elaborate and minimizes momentary transfer interruptions.

## Multiple or parallel redundant generator systems

The question of "how many?" is closely related to the desired capacity and reliability of the system. A system with multiple (identical) smaller units that sum to the required peak load, with one additional unit, is known as N+1 redundant. An example, as illustrated in **Figure 4** is 3 x 800 kW generator systems synchronized together and supporting a 1.6 MW facility load, while having the third 800 kW in reserve.

**Figure 4**

*1.6 MW N+1 redundant isochronous generator system*

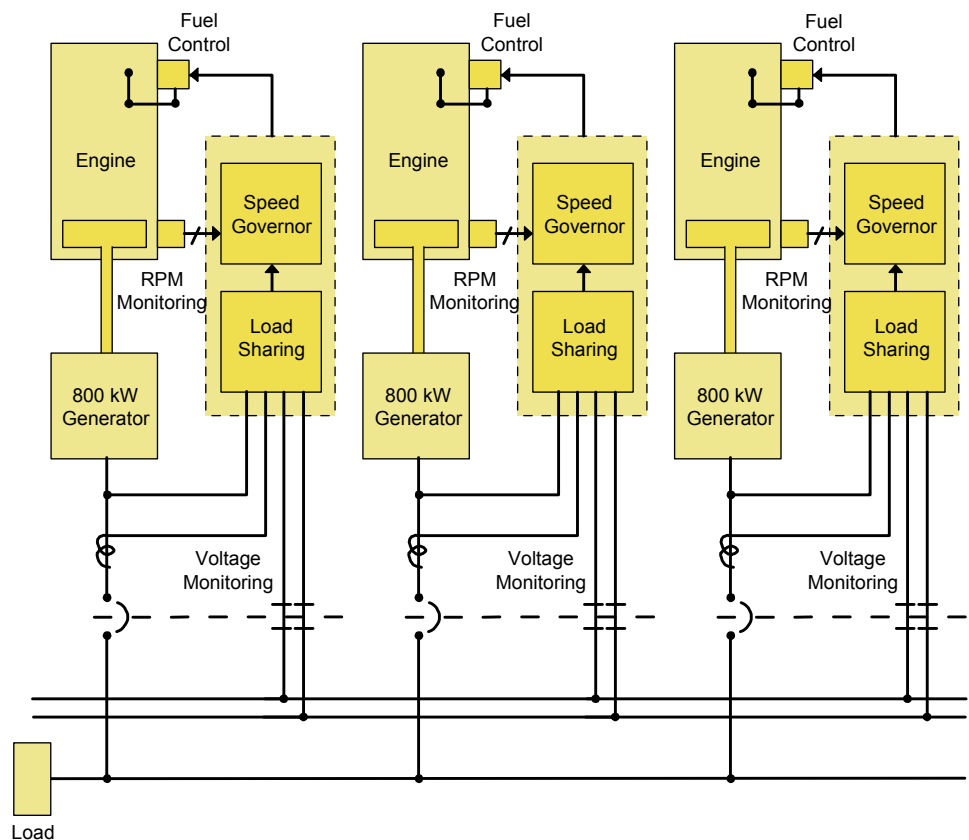

The initiation of their startup sequence fires up all three generators and synchronizes them together. A load of 1.6 MW can now be supported with N+1 redundancy. Paralleling switchgear will add cost, but increases the statistical reliability over a solitary prime mover. In this example the likelihood of more than one generator system being down at a given time is small compared to that of a single generator system. This is, of course, with the recognition that a common-cause failure, such as running out of fuel, can ruin a seemingly redundant plan.

Another key benefit to the building-block concept - adding up smaller systems to the size of the load - is its scalability. Growing facilities may elect to design a system with provisions to add more elements of capacity in the future, where space is allocated and ampacity of wiring

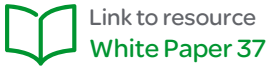

Link to resource

**White Paper 37**

*Avoiding Costs from Oversizing  
Data Center and Network Room  
Infrastructure*

## Overall system and compatibility design

is pre-selected at its eventual load. The capital cost and implied maintenance is deferred until the growth in the critical load warrants the investment. It is important to evaluate needs carefully and apply sound judgment to the selection in accordance with the earlier definitions. For more information on scalability see White Paper 37, *Avoiding Costs from Oversizing Data Center and Network Room Infrastructure*.

It is important to emphasize the influences of power factor, transfer switches, and UPS on the overall performance of the combined system. When multiple vendors are involved it is essential that all vendors in the project partake in a comprehensive installation testing and commissioning process. This type of plan can reveal unanticipated compatibility concerns before they influence the critical loads. Such testing should be done at a variety of loads, up to full 100% utilization. Often, load banks must be brought in to substitute for the intended loads. Be conscious of the fact that this may not represent the power factor of the computer loads. If specialized reactive load banks are not available, an additional test regimen should be performed with the actual loads once available.

One way to avoid the complexity and multi-vendor testing of customized generators, ATS, and UPS solutions is to specify a complete system that has been pre-engineered, manufactured and pre-tested under ISO 9000 standards by a single vendor. Another benefit of pre-engineered systems is the continually increasing quality and reliability as a result of standardized manufacturing techniques that drive out defects also known as reliability growth.

## Conclusion

The prime mover supplies the energy to the generator system, and requires an accurate governor to produce stable frequency under changing loads. The alternator, voltage regulator, and other controls are required to create and deliver quality AC to the transfer switch to be fed to the critical loads. Traditional generator systems can be complex in nature, leading to more costly engineering work and greater potential for failures. Alternative pre-engineered systems provide increased reliability through standardized manufacturing techniques.



## Acknowledgements

Special thanks to **Robert Wolfgang** for authoring the original content of this white paper.



## Resources

Click on icon to link to resource



### Allocating Data Center Energy Costs and Carbon to IT Users

White Paper 90



### Avoiding Costs from Oversizing Data Center and Network Room Infrastructure

White Paper 37



### White Paper Library

[whitepapers.apc.com](http://whitepapers.apc.com)



### TradeOff Tools™

[tools.apc.com](http://tools.apc.com)

## References

1. NFPA 110, Standard for Emergency and Standby Power Systems, 1999 Edition, National Fire Prevention Association, 1999 (<http://www.nfpa.org>)
2. NFPA 111, Standard on Stored Electrical Energy Emergency and Standby Power Systems, 1996 Edition  
National Fire Prevention Association, 1999
3. IEEE Standard 446-1995, IEEE Recommended Practice for Emergency and Standby Power Systems for Industrial and Commercial Applications (Orange Book) (<http://iee.org>)
4. IEEE Standard 1100-1999, IEEE Recommended Practice for Powering and Grounding Electronic Equipment. (Emerald Book)
5. IEEE Standard 602-1996, IEEE Recommended Practice for Electric Systems in Health Care Facilities, (White Book)
6. EGSA Standards 100, 101, & 404 (<http://www.egsa.org>)
7. "On-Site Power Generation," Electrical Generating Systems Association, 1998 ISBN 0-9625949-3-8



## Contact us

For feedback and comments about the content of this white paper:

Data Center Science Center  
[DCSC@Schneider-Electric.com](mailto:DCSC@Schneider-Electric.com)

If you are a customer and have questions specific to your data center project:

Contact your **Schneider Electric** representative