

FRONT VIEW

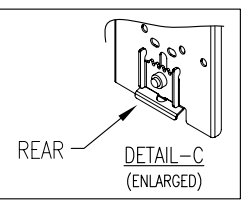

REAR DETAIL-C (ENLARGED)

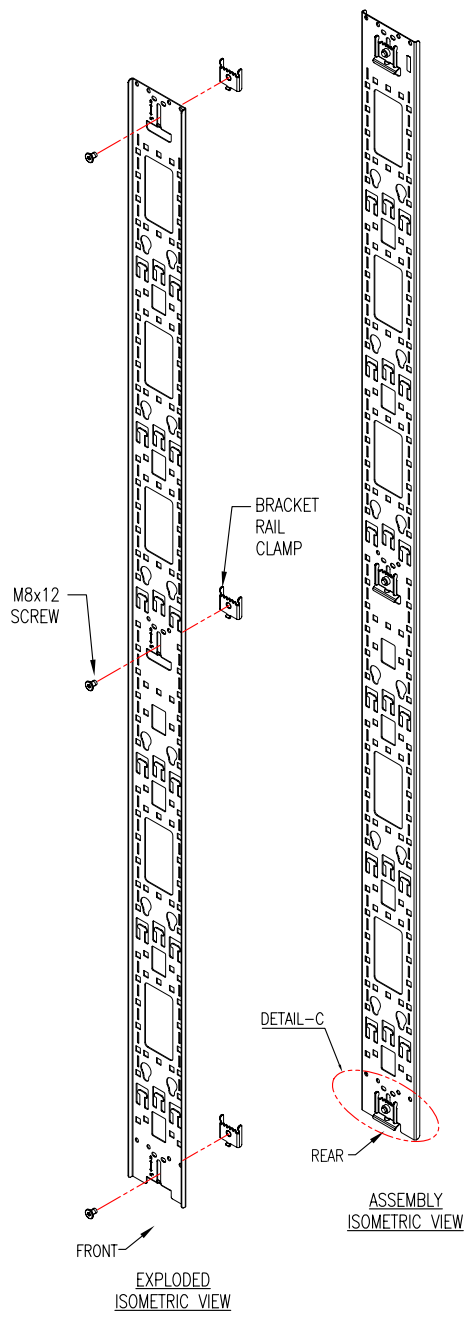
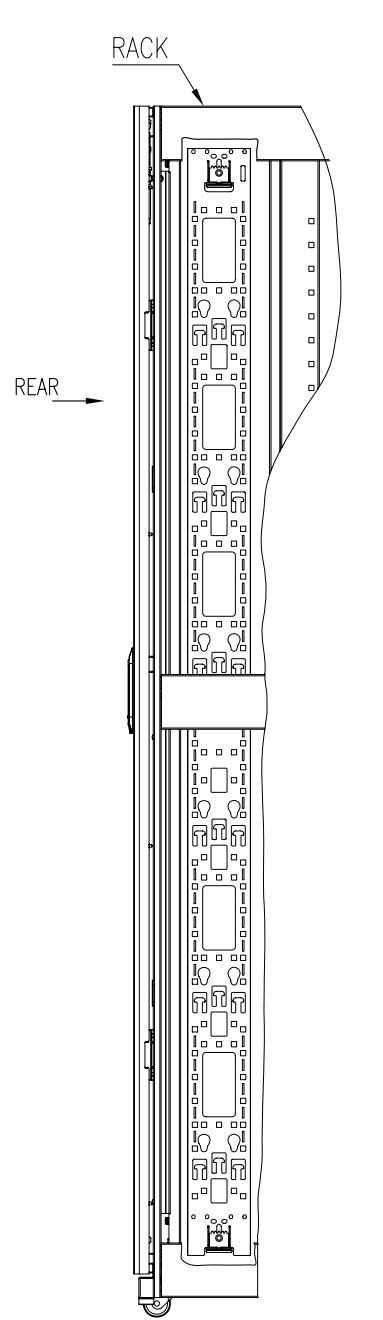

TYPICAL MOUNTING INSIDE THE RACK (RACK SIDE COVERS REMOVED)

NOTES:

1. INSTALLATION MUST COMPLY WITH NATIONAL AND LOCAL ELECTRICAL REGULATIONS.
2. PLEASE REFER TO THE PRODUCT MANUAL FOR DETAILS.
3. UNLESS OTHERWISE SPECIFIED, ALL DIMENSIONS ARE IN MILLIMETERS [INCHES].
4. NET WEIGHT OF UNIT IS 4.66 kg [10.25 lbs].

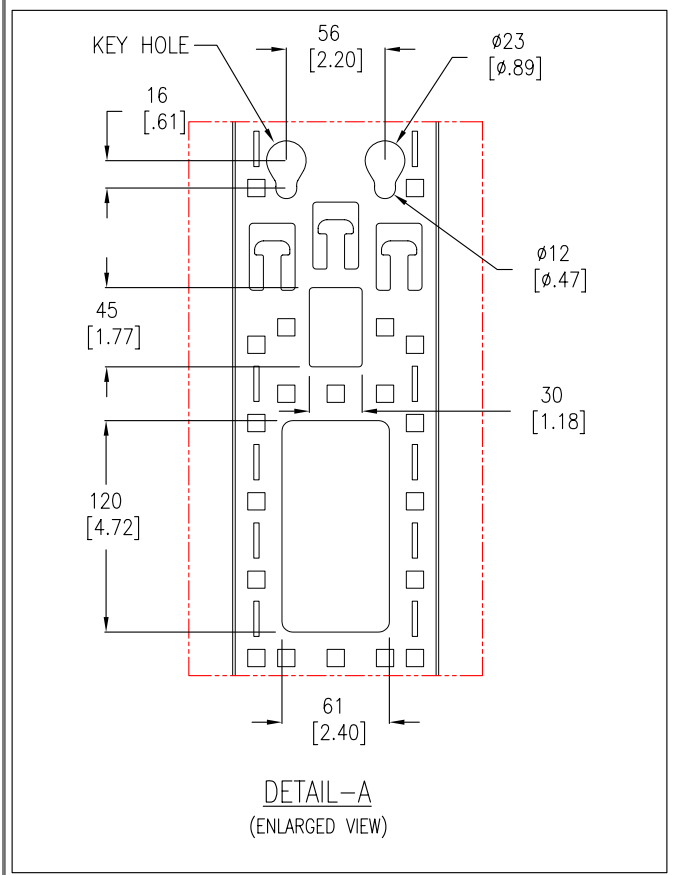

DETAIL-A (ENLARGED VIEW)

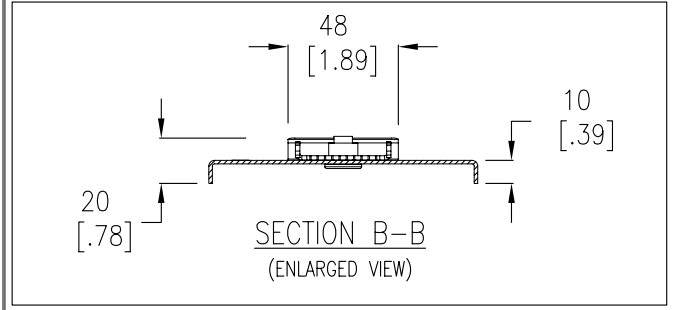

SECTION B-B (ENLARGED VIEW)

THIS DRAWING AND SPECIFICATIONS HEREIN ARE THE PROPERTY OF SCHNEIDER ELECTRIC AND SHALL NOT BE COPIED, REPRODUCED OR USED IN WHOLE OR IN PART, AS THE BASIS FOR THE MANUFACTURE OR SALE OF ITEMS WITHOUT WRITTEN PERMISSION FROM SCHNEIDER ELECTRIC. THIS DRAWING IS BASED UPON LATEST AVAILABLE INFORMATION AND IS SUBJECT TO CHANGE WITHOUT NOTICE.



TITLE: RACKS AND ACCESSORIES CABLE MANAGEMENT Vertical Cable Organizers, NetShelter SX-45U MAIN MECHANICAL	DWG NO: AR7552	REV: 0
PROJECT: SUBMITTAL DRAWINGS SHEET 1 OF 1	DRAWN BY: K.NAGENDRA ENGINEER: J.KUMMER	09-MAY-12 09-MAY-12
	APPROVED BY: S.VOCCIO	09-MAY-12
		FIRST ANGLE PROJECTION