

Galaxy VS

Maintenance Bypass Cabinet

Installation

GVSBPUSU150G, GVSBPUSU80G

Latest updates are available on the Schneider Electric website
5/2024



Legal Information

The information provided in this document contains general descriptions, technical characteristics and/or recommendations related to products/solutions.

This document is not intended as a substitute for a detailed study or operational and site-specific development or schematic plan. It is not to be used for determining suitability or reliability of the products/solutions for specific user applications. It is the duty of any such user to perform or have any professional expert of its choice (integrator, specifier or the like) perform the appropriate and comprehensive risk analysis, evaluation and testing of the products/solutions with respect to the relevant specific application or use thereof.

The Schneider Electric brand and any trademarks of Schneider Electric SE and its subsidiaries referred to in this document are the property of Schneider Electric SE or its subsidiaries. All other brands may be trademarks of their respective owner.

This document and its content are protected under applicable copyright laws and provided for informative use only. No part of this document may be reproduced or transmitted in any form or by any means (electronic, mechanical, photocopying, recording, or otherwise), for any purpose, without the prior written permission of Schneider Electric.

Schneider Electric does not grant any right or license for commercial use of the document or its content, except for a non-exclusive and personal license to consult it on an "as is" basis.

Schneider Electric reserves the right to make changes or updates with respect to or in the content of this document or the format thereof, at any time without notice.

To the extent permitted by applicable law, no responsibility or liability is assumed by Schneider Electric and its subsidiaries for any errors or omissions in the informational content of this document, as well as any non-intended use or misuse of the content thereof.

Table of Contents

Important Safety Instructions — SAVE THESE	
INSTRUCTIONS	5
FCC Statement	6
Safety Precautions	6
Additional Safety Precautions After Installation.....	8
Electrical Safety	8
Battery Safety	9
Specifications	11
Maximum Short Circuit Rating	11
Specifications for 480 V Systems	12
Trip Settings for 480 V	12
Recommended Upstream Protection 480 V	12
Recommended Cable Sizes 480 V	13
Specifications for 208 V Systems	14
Trip Settings for 200/208/220 V	14
Recommended Upstream Protection 200/208/220 V	14
Recommended Cable Sizes 200/208/220 V	15
Specifications for 400 V Systems	16
Trip Settings for 400/415 V	16
Recommended Upstream Protection 400/415 V	17
Recommended Cable Sizes 400/415 V.....	18
Recommended Bolt and Lug Sizes	19
Torque Specifications.....	19
Maintenance Bypass Cabinet Weights and Dimensions.....	20
Clearance	20
Environment.....	20
System Overview	21
Overview of Installation Kits	22
Optional Seismic Kit GVSOPT003	26
Optional Kirk Key Kit GVSOPT004.....	27
Installation Procedure for Top Cable Entry	28
Installation Procedure for Bottom Cable Entry	30
Prepare the Maintenance Bypass Cabinet and the UPS for Cables	31
Install the Conduit Box	34
Connect the Internal Power Cables	35
Install the Seismic Anchoring (Option)	37
Connect the Power Cables in a 10-80 kW Top Cable Entry System	39
Connect the Power Cables in a 100-150 kW Top Cable Entry System	41
Restrain the Cables	43
Connect the Power Cables in a Bottom Cable Entry System	45
Interconnect the UPS and the Maintenance Bypass Cabinet	46

Connect the Signal Cables	51
Final Installation	54
Decommission or Move the Maintenance Bypass Cabinet to a New Location	57

Important Safety Instructions — SAVE THESE INSTRUCTIONS

Read these instructions carefully and look at the equipment to become familiar with it before trying to install, operate, service or maintain it. The following safety messages may appear throughout this manual or on the equipment to warn of potential hazards or to call attention to information that clarifies or simplifies a procedure.



The addition of this symbol to a “Danger” or “Warning” safety message indicates that an electrical hazard exists which will result in personal injury if the instructions are not followed.



This is the safety alert symbol. It is used to alert you to potential personal injury hazards. Obey all safety messages with this symbol to avoid possible injury or death.

DANGER

DANGER indicates a hazardous situation which, if not avoided, **will result in death or serious injury.**

Failure to follow these instructions will result in death or serious injury.

WARNING

WARNING indicates a hazardous situation which, if not avoided, **could result in death or serious injury.**

Failure to follow these instructions can result in death, serious injury, or equipment damage.

CAUTION

CAUTION indicates a hazardous situation which, if not avoided, **could result in minor or moderate injury.**

Failure to follow these instructions can result in injury or equipment damage.

NOTICE

NOTICE is used to address practices not related to physical injury. The safety alert symbol shall not be used with this type of safety message.

Failure to follow these instructions can result in equipment damage.

Please Note

Electrical equipment should only be installed, operated, serviced, and maintained by qualified personnel. No responsibility is assumed by Schneider Electric for any consequences arising out of the use of this material.

A qualified person is one who has skills and knowledge related to the construction, installation, and operation of electrical equipment and has received safety training to recognize and avoid the hazards involved.

FCC Statement

NOTE: This equipment has been tested and found to comply with the limits for a Class A digital device, pursuant to Part 15 of the FCC Rules. These limits are designed to provide reasonable protection against harmful interference when the equipment is operated in a commercial environment. This equipment generates, uses, and can radiate radio frequency energy and, if not installed and used in accordance with the instruction manual, may cause harmful interference to radio communications. Operation of this equipment in a residential area is likely to cause harmful interference in which case the user will be required to correct the interference at his own expense.

Any changes or modifications not expressly approved by the party responsible for compliance could void the user's authority to operate the equipment.

Safety Precautions

DANGER

HAZARD OF ELECTRIC SHOCK, EXPLOSION, OR ARC FLASH

Read all instructions in the installation manual before installing or working on this product.

Failure to follow these instructions will result in death or serious injury.

DANGER

HAZARD OF ELECTRIC SHOCK, EXPLOSION, OR ARC FLASH

Do not install the product until all construction work has been completed and the installation room has been cleaned.

Failure to follow these instructions will result in death or serious injury.

DANGER

HAZARD OF ELECTRIC SHOCK, EXPLOSION, OR ARC FLASH

The product must be installed according to the specifications and requirements as defined by Schneider Electric. It concerns in particular the external and internal protections (upstream breakers, battery breakers, cabling, etc.) and environmental requirements. No responsibility is assumed by Schneider Electric if these requirements are not respected.

Failure to follow these instructions will result in death or serious injury.

DANGER

HAZARD OF ELECTRIC SHOCK, EXPLOSION, OR ARC FLASH

The UPS system must be installed according to local and national regulations. Install the UPS system according to:

- IEC 60364 (including 60364-4-41- protection against electric shock, 60364-4-42 - protection against thermal effect, and 60364-4-43 - protection against overcurrent), **or**
- NEC NFPA 70, **or**
- Canadian Electrical Code (C22.1, Part 1)

depending on which one of the standards apply in your local area.

Failure to follow these instructions will result in death or serious injury.

⚠ ⚠ DANGER

HAZARD OF ELECTRIC SHOCK, EXPLOSION, OR ARC FLASH

- Install the product in a temperature controlled indoor environment free of conductive contaminants and humidity.
- Install the product on a non-flammable, level and solid surface (e.g. concrete) that can support the weight of the system.

Failure to follow these instructions will result in death or serious injury.

⚠ ⚠ DANGER

HAZARD OF ELECTRIC SHOCK, EXPLOSION, OR ARC FLASH

The product is not designed for and must therefore not be installed in the following unusual operating environments:

- Damaging fumes
- Explosive mixtures of dust or gases, corrosive gases, or conductive or radiant heat from other sources
- Moisture, abrasive dust, steam or in an excessively damp environment
- Fungus, insects, vermin
- Salt-laden air or contaminated cooling refrigerant
- Pollution degree higher than 2 according to IEC 60664-1
- Exposure to abnormal vibrations, shocks, and tilting
- Exposure to direct sunlight, heat sources, or strong electromagnetic fields

Failure to follow these instructions will result in death or serious injury.

⚠ ⚠ DANGER

HAZARD OF ELECTRIC SHOCK, EXPLOSION, OR ARC FLASH

Do not drill or cut holes for cables or conduits with the gland plates installed and do not drill or cut holes in close proximity to the UPS system.

Failure to follow these instructions will result in death or serious injury.

⚠ ⚠ WARNING

HAZARD OF ARC FLASH

Do not make mechanical changes to the product (including removal of cabinet parts or drilling/cutting of holes) that are not described in the installation manual.

Failure to follow these instructions can result in death, serious injury, or equipment damage.

NOTICE

RISK OF OVERHEATING

Respect the space requirements around the product and do not cover the ventilation openings when the product is in operation.

Failure to follow these instructions can result in equipment damage.

Additional Safety Precautions After Installation

DANGER

HAZARD OF ELECTRIC SHOCK, EXPLOSION, OR ARC FLASH

Do not install the UPS system until all construction work has been completed and the installation room has been cleaned. If additional construction work is needed in the installation room after this product has been installed, turn off the product and cover the product with the protective packaging bag the product was delivered in.

Failure to follow these instructions will result in death or serious injury.

Electrical Safety

This manual contains important safety instructions that should be followed during the installation and maintenance of the UPS system.

DANGER

HAZARD OF ELECTRIC SHOCK, EXPLOSION, OR ARC FLASH

- Electrical equipment must be installed, operated, serviced, and maintained only by qualified personnel.
- Apply appropriate personal protective equipment (PPE) and follow safe electrical work practices.
- Disconnection devices for AC and DC must be provided by others, be readily accessible, and the function of the disconnect device marked for its function.
- Turn off all power supplying the UPS system before working on or inside the equipment.
- Before working on the UPS system, check for hazardous voltage between all terminals including the protective earth.
- The UPS contains an internal energy source. Hazardous voltage can be present even when disconnected from the mains supply. Before installing or servicing the UPS system, ensure that the units are OFF and that mains and batteries are disconnected. Wait five minutes before opening the UPS to allow the capacitors to discharge.
- The UPS must be properly earthed/grounded and due to a high leakage current, the earthing/grounding conductor must be connected first.

Failure to follow these instructions will result in death or serious injury.

When the UPS input is connected through external isolators that, when opened, isolate the neutral or when the automatic backfeed isolation is provided external to the equipment or is connected to an IT power distribution system, a label must be fitted at the UPS input terminals, and on all primary power isolators installed remotely from the UPS area and on external access points between such isolators and the UPS, by the user, displaying the following text (or equivalent in a language which is acceptable in the country in which the UPS system is installed):

DANGER

HAZARD OF ELECTRIC SHOCK, EXPLOSION, OR ARC FLASH

Risk of voltage backfeed. Before working on this circuit: Isolate the UPS and check for hazardous voltage between all terminals including the protective earth.

Failure to follow these instructions will result in death or serious injury.

Battery Safety

DANGER

HAZARD OF ELECTRIC SHOCK, EXPLOSION, OR ARC FLASH

- Battery circuit breakers must be installed according to the specifications and requirements as defined by Schneider Electric.
- Servicing of batteries must only be performed or supervised by qualified personnel knowledgeable of batteries and the required precautions. Keep unqualified personnel away from batteries.
- Disconnect charging source prior to connecting or disconnecting battery terminals.
- Do not dispose of batteries in a fire as they can explode.
- Do not open, alter, or mutilate batteries. Released electrolyte is harmful to the skin and eyes. It may be toxic.

Failure to follow these instructions will result in death or serious injury.

DANGER

HAZARD OF ELECTRIC SHOCK, EXPLOSION, OR ARC FLASH

Batteries can present a risk of electric shock and high short-circuit current. The following precautions must be observed when working on batteries

- Remove watches, rings, or other metal objects.
- Use tools with insulated handles.
- Wear protective glasses, gloves and boots.
- Do not lay tools or metal parts on top of batteries.
- Disconnect the charging source prior to connecting or disconnecting battery terminals.
- Determine if the battery is inadvertently grounded. If inadvertently grounded, remove source from ground. Contact with any part of a grounded battery can result in electric shock. The likelihood of such shock can be reduced if such grounds are removed during installation and maintenance (applicable to equipment and remote battery supplies not having a grounded supply circuit).

Failure to follow these instructions will result in death or serious injury.

DANGER

HAZARD OF ELECTRIC SHOCK, EXPLOSION, OR ARC FLASH

When replacing batteries, always replace with the same type and number of batteries or battery packs.

Failure to follow these instructions will result in death or serious injury.

▲ CAUTION**RISK OF EQUIPMENT DAMAGE**

- Mount the batteries in the UPS system, but do not connect the batteries until the UPS system is ready to be powered up. The time duration from battery connection until the UPS system is powered up must not exceed 72 hours or 3 days.
- Batteries must not be stored more than six months due to the requirement of recharging. If the UPS system remains de-energized for a long period, we recommend that you energize the UPS system for a period of 24 hours at least once every month. This charges the batteries, thus avoiding irreversible damage.

Failure to follow these instructions can result in injury or equipment damage.

Specifications

Maximum Short Circuit Rating

The maximum short circuit rating for the maintenance bypass cabinet is 65 kA RMS symmetrical.

Specifications for 480 V Systems

Trip Settings for 480 V

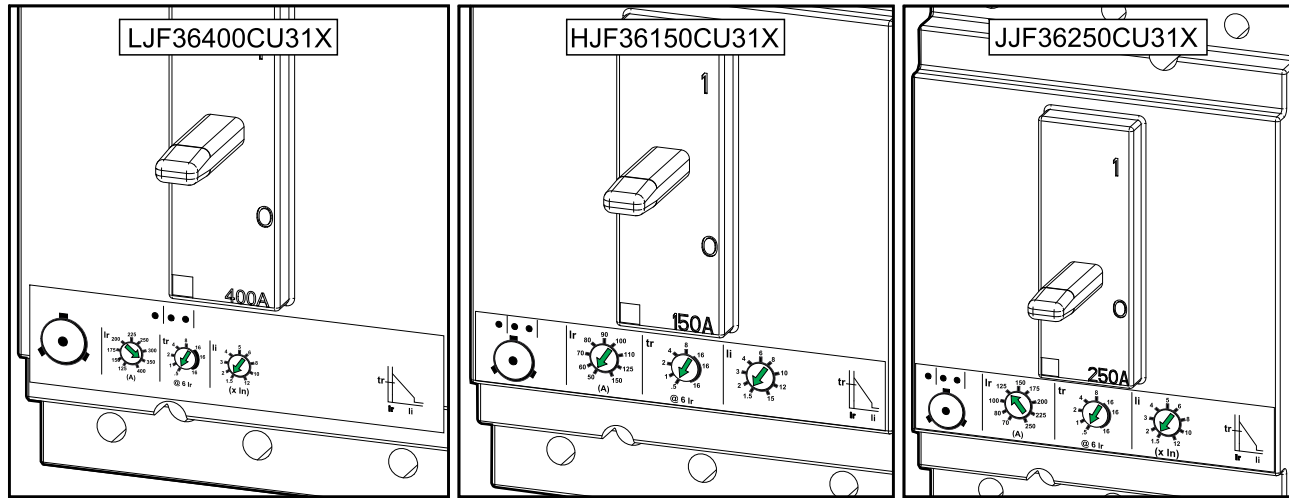

UPS rating	Breaker type		Ir (A)	tr at 6 lr	li (x In)	tr at 6 lr	li (x In)
	UIB/SSIB	MBB/UOB	UIB/SSIB/MBB/UOB	UIB/SSIB		MBB/UOB	
20 kW	HJF36150CU31X	HJF36150CU31X	50	1	4	0.5	4
30 kW	HJF36150CU31X	HJF36150CU31X	50	1	5	0.5	5
40 kW	HJF36150CU31X	HJF36150CU31X	70	1	5	0.5	5
50 kW	HJF36150CU31X	HJF36150CU31X	80	1	5	0.5	5
60 kW	HJF36150CU31X	HJF36150CU31X	100	1	12	0.5	12
80 kW	HJF36150CU31X	HJF36150CU31X	125	1	12	0.5	12
100 kW	LJF36400CU31X	JJF36250CU31X	175	1	8	0.5	10
120 kW	LJF36400CU31X	JJF36250CU31X	200	1	8	0.5	12
150 kW	LJF36400CU31X	JJF36250CU31X	250	1	8	0.5	12

Recommended Upstream Protection 480 V

UPS rating	20 kW		30 kW		40 kW		50 kW	
	Input	Bypass	Input	Bypass	Input	Bypass	Input	Bypass
Breaker type	HJF36100U31X							
Ir (A)	40	35	60	50	80	70	100	80
tr at 6 lr	0.5							
li (x In)	1.5							

UPS rating	60 kW		80 kW		100 kW		120 kW		150 kW	
	Input	Bypass	Input	Bypass	Input	Bypass	Input	Bypass	Input	Bypass
Breaker type	HJ-F36150-U31X	HJ-F36100-U31X	JJ-F36250-U31X	HJ-F36150-U31X	JJF36250U31X				LJ-F36400-U31X	JJ-F36250-U31X
Ir (A)	125	100	175	125	200	175	250	200	300	250
tr at 6 lr	0.5									
li (x In)	1.5									

Recommended Cable Sizes 480 V

⚠️ ⚠️ DANGER

HAZARD OF ELECTRIC SHOCK, EXPLOSION, OR ARC FLASH

All wiring must comply with all applicable national and/or electrical codes. The maximum allowable cable size is 4/0 AWG.

Failure to follow these instructions will result in death or serious injury.

NOTE: Overcurrent protection is to be provided by others.

Cable sizes in this manual are based on Table 310.15 (B)(16) of the National Electrical Code (NEC) with the following assertions:

- 90 °C (194 °F) conductors (75 °C (167 °F) termination)
- An ambient temperature of 30 °C (86 °F)
- Use of copper conductors

If the ambient temperature is greater than 30 °C (86 °F), larger conductors are to be selected in accordance with the correction factors of the NEC.

Equipment grounding conductors (PE in this manual) are sized in accordance with NEC Article 250.122 and Table 250.122.

UPS rating	20 kW	30 kW	40 kW	50 kW	60 kW	80 kW	100 kW	120 kW	150 kW
Input phases (AWG/kcmil)	8	6	4	3	1	2/0	2 x 1/0	2 x 1/0	2 x 1/0
Input PE (AWG/kcmil)	10	8	8	6	6	6	4	2 x 4	2 x 3
Bypass/output phases (AWG/kcmil)	10	8	6	4	3	1	2/0	2 x 1/0	2 x 1/0
Bypass PE/output PE (AWG/kcmil)	10	10	8	8	8	6	6	2 x 6	2 x 4
Neutral (AWG/kcmil)	6	4	2	1/0	2/0	2 x 1/0	2 x 1/0	4 x 1/0	4 x 1/0
DC +/- (AWG/kcmil)	4 ²	2 ²	1/0 ²	1/0 ³	2/0 ³	4/0 ³	2 x 1/0 ³	2 x 3/0 ³	2 x 4/0 ³
DC PE (AWG/kcmil)	8	6	6	6	6	4	4	3	2 x 2

NOTE: The DC cable sizes given here are recommendations – Always follow the specific instructions in the battery solution documentation for DC +/- and DC PE cable sizes.

NOTE: For 120 kW, use two separate conduits for each of the input, bypass, and output cable sets. Organize cables as illustrated in each conduit to avoid eddy currents (heating).

NOTE: For 150 kW, use two separate conduits for each of the input, bypass, output, and DC cable sets. Organize cables as illustrated in each conduit to avoid eddy currents (heating).

Cable Organization in Separate Conduits for Input/Bypass/Output and DC

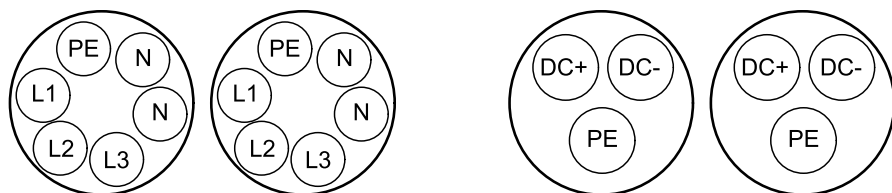

1. Neutral conductor is sized to handle 1.73 times phase current in case of high harmonic content from non-linear loads. If low or no harmonic currents are expected, neutral conductor can be sized as phase conductor.
2. 20-40 kW: DC cables are sized according to 32 battery blocks.
3. 50 kW and higher: DC cables are sized according to 40 battery blocks.

Specifications for 208 V Systems

Trip Settings for 200/208/220 V

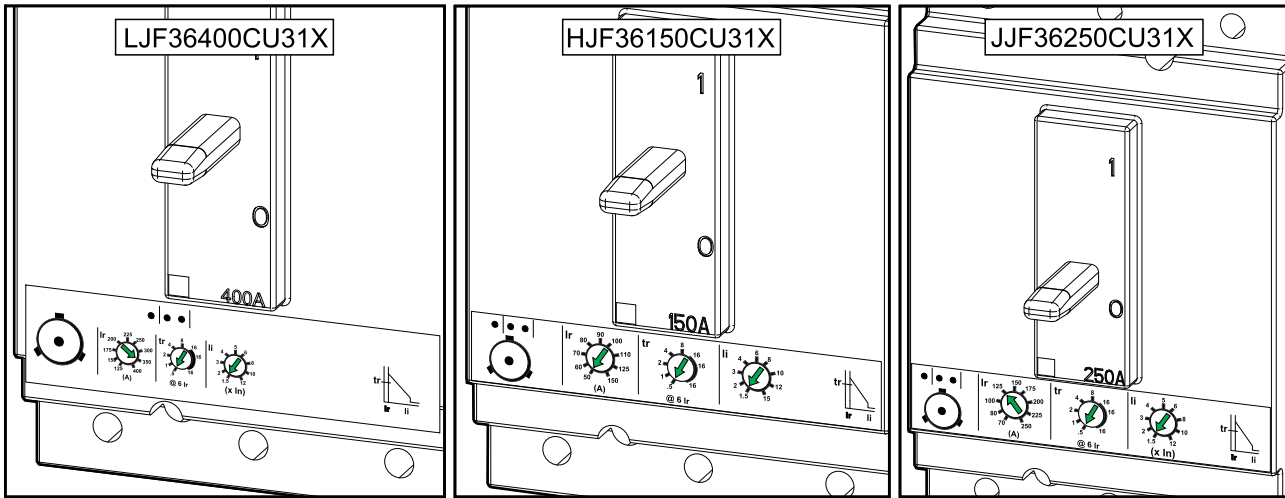

UPS rating	Breaker type		Ir (A)		tr at 6 lr	li (x In)	tr at 6 lr	li (x In)
	UIB/SSIB	MBB/UOB	UIB	SSIB/ MBB/UOB	UIB/SSIB		MBB/UOB	
10 kW	HJF36150CU31X	HJF36150CU31X	50	50	1	4	0.5	4
15 kW	HJF36150CU31X	HJF36150CU31X	60	60	1	5	0.5	5
20 kW	HJF36150CU31X	HJF36150CU31X	80	80	1	5	0.5	5
25 kW	HJF36150CU31X	HJF36150CU31X	100	100	1	5	0.5	5
30 kW	HJF36150CU31X	HJF36150CU31X	125	110	1	12	0.5	12
40 kW	HJF36150CU31X	HJF36150CU31X	150	150	1	12	0.5	12
50 kW	LJF36400CU31X	JJF36250CU31X	200	200	1	8	0.5	10
60 kW	LJF36400CU31X	JJF36250CU31X	250	225	1	8	0.5	12
75 kW	LJF36400CU31X	JJF36250CU31X	300	250	1	8	0.5	12

Recommended Upstream Protection 200/208/220 V

UPS rating	10 kW		15 kW		20 kW		25 kW	
	Input	Bypass	Input	Bypass	Input	Bypass	Input	Bypass
Breaker type	HJF36100U31X						HJF36150-U31X	HJF36100-U31X
Ir (A)	50	40	80	60	100	80	125	100
tr at 6 lr	0.5							
li (x In)	1.5							

UPS rating	30 kW		40 kW		50 kW		60 kW		75 kW	
	Input	Bypass	Input	Bypass	Input	Bypass	Input	Bypass	Input	Bypass
Breaker type	HJF36150U31X		JJ-F36250-U31X	HJ-F36150-U31X	JJF36250U31X		LJ-F36400-U31X	JJ-F36250-U31X	LJF36400U31X	
Ir (A)	150	110	200	150	250	200	300	225	350	300
tr at 6 lr	0.5									
li (x In)	1.5									

Recommended Cable Sizes 200/208/220 V

⚡ ⚠ DANGER

HAZARD OF ELECTRIC SHOCK, EXPLOSION, OR ARC FLASH

All wiring must comply with all applicable national and/or electrical codes. The maximum allowable cable size is 4/0 AWG.

Failure to follow these instructions will result in death or serious injury.

NOTE: Overcurrent protection is to be provided by others.

Cable sizes in this manual are based on Table 310.15 (B)(16) of the National Electrical Code (NEC) with the following assertions:

- 90 °C (194 °F) conductors (75 °C (167 °F) termination)
- An ambient temperature of 30 °C (86 °F)
- Use of copper conductors

If the ambient temperature is greater than 30 °C (86 °F), larger conductors are to be selected in accordance with the correction factors of the NEC.

Equipment grounding conductors (PE in this manual) are sized in accordance with NEC Article 250.122 and Table 250.122.

UPS rating	10 kW	15 kW	20 kW	25 kW	30 kW	40 kW	50 kW	60 kW	75 kW
Input phases (AWG/kcmil)	8	4	3	2	1/0	2 x 1/0	2 x 1/0	2 x 1/0	2 x 2/0
Input PE (AWG/kcmil)	10	8	8	6	6	6	2 x 4	2 x 4	2 x 3
Bypass/output phases (AWG/kcmil)	8	6	4	3	2	1/0	2 x 1/0	2 x 1/0	2 x 1/0
Bypass PE/output PE (AWG/kcmil)	10	10	8	8	6	6	2 x 6	2 x 4	2 x 4
Neutral (AWG/kcmil) 4	6	3	1	2/0	2 x 1/0	2 x 1/0	2 x 2/0	4 x 1/0	4 x 1/0
DC +/- (AWG/kcmil)	10 ⁵	6 ⁵	4 ⁵	4 ⁵	2 ⁵	1/0 ⁵	2/0 ⁵	4/0 ⁵	2 x 1/0 ⁵
DC PE (AWG/kcmil)	10	10	8	8	6	6	6	4	4

NOTE: The DC cable sizes given here are recommendations – Always follow the specific instructions in the battery solution documentation for DC +/- and DC PE cable sizes.

NOTE: For 50 kW, 60 kW, and 75 kW, use two separate conduits for each of the input, bypass, and output cable sets. Organize cables as illustrated in each conduit to avoid eddy currents (heating).

Cable Organization in Separate Conduits for Input/Bypass/Output and DC

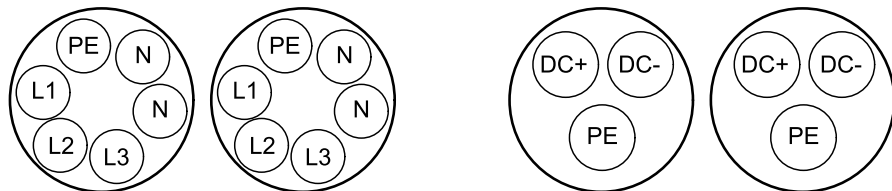

4. Neutral conductor is sized to handle 1.73 times phase current in case of high harmonic content from non-linear loads. If low or no harmonic currents are expected, neutral conductor can be sized as phase conductor.
5. DC cables are sized according to 32 battery blocks.

Specifications for 400 V Systems

Trip Settings for 400/415 V

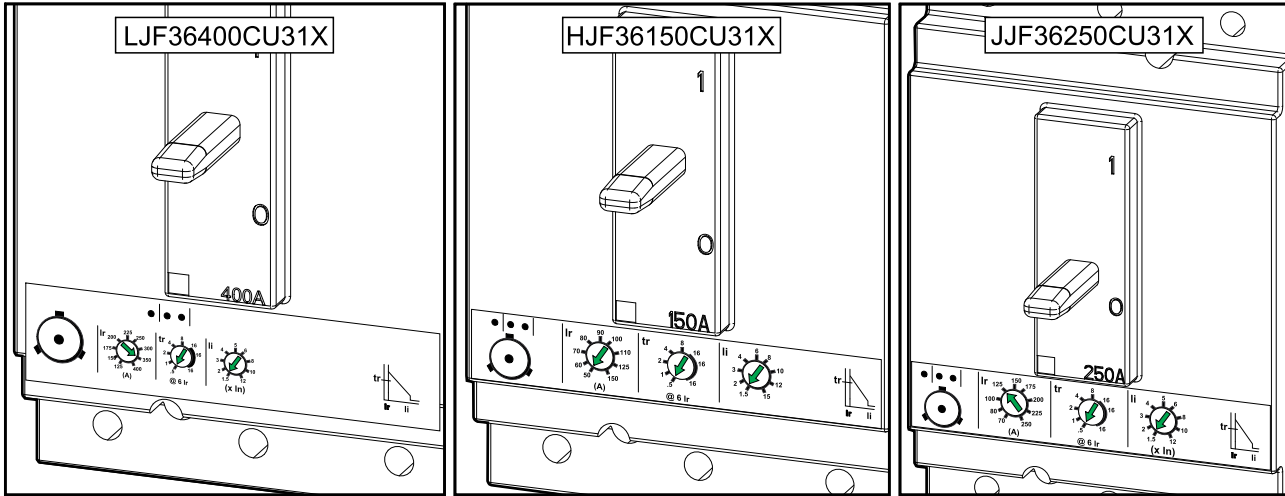

UPS rating	Breaker type		Ir (A)		tr at 6 lr	li (x In)	tr at 6 lr	li (x In)
	UIB/SSIB	MBB/UOB	UIB	SSIB/ MBB/UOB	UIB/SSIB	MBB/UOB		
10 kW	HJF36150CU31X	HJF36150CU31X	50	50	1	4	0.5	4
15 kW	HJF36150CU31X	HJF36150CU31X	50	50	1	4	0.5	4
20 kW	HJF36150CU31X	HJF36150CU31X	50	50	1	4	0.5	4
30 kW	HJF36150CU31X	HJF36150CU31X	60	60	1	5	0.5	5
40 kW	HJF36150CU31X	HJF36150CU31X	80	80	1	5	0.5	5
50 kW	HJF36150CU31X	HJF36150CU31X	100	100	1	5	0.5	5
60 kW	HJF36150CU31X	HJF36150CU31X	125	110	1	12	0.5	12
80 kW	HJF36150CU31X	HJF36150CU31X	150	150	1	12	0.5	12
100 kW	LJF36400CU31X	JJF36250CU31X	200	200	1	8	0.5	10
120 kW	LJF36400CU31X	JJF36250CU31X	250	225	1	8	0.5	12
150 kW	LJF36400CU31X	JJF36250CU31X	300	250	1	8	0.5	12

Recommended Upstream Protection 400/415 V

UPS rating	10 kW		15 kW		20 kW		30 kW		40 kW		50 kW	
	Input	By-pass	Input	By-pass	Input	By-pass	Input	By-pass	Input	By-pass	Input	By-pass
Breaker type	HJF36060U31X				HJF36100U31X						HJ-F3615-0U31X	HJ-F3610-0U31X
I _r (A)	25	20	35	30	50	40	80	60	100	80	125	100
tr at 6 I _r	0.5											
li (x I _n)	1.5											

UPS rating	60 kW		80 kW		100 kW		120 kW		150 kW	
	Input	Bypass	Input	Bypass	Input	Bypass	Input	Bypass	Input	Bypass
Breaker type	HJF36150U31X		JJ-F36250-U31X	HJ-F36150-U31X	JJF36250U31X		LJ-F36400-U31X	JJ-F36250-U31X	LJF36400U31X	
I _r (A)	150	110	200	150	250	200	300	225	350	300
tr at 6 I _r	0.5									
li (x I _n)	1.5									

Recommended Cable Sizes 400/415 V

⚡⚠ DANGER

HAZARD OF ELECTRIC SHOCK, EXPLOSION, OR ARC FLASH

All wiring must comply with all applicable national and/or electrical codes. The maximum allowable cable size is 4/0 AWG.

Failure to follow these instructions will result in death or serious injury.

NOTE: Overcurrent protection is to be provided by others.

Cable sizes in this manual are based on Table 310.15 (B)(16) of the National Electrical Code (NEC) with the following assertions:

- 90 °C (194 °F) conductors (75 °C (167 °F) termination)
- An ambient temperature of 30 °C (86 °F)
- Use of copper conductors

If the ambient temperature is greater than 30 °C (86 °F), larger conductors are to be selected in accordance with the correction factors of the NEC.

Equipment grounding conductors (PE in this manual) are sized in accordance with NEC Article 250.122 and Table 250.122.

UPS rating	10 kW	15 kW	20 kW	30 kW	40 kW	50 kW	60 kW	80 kW	100 kW	120 kW	150 kW
Input phases (AWG/kcmil)	8	8	8	4	3	2	1/0	2 x 1/0	2 x 1/0	2 x 1/0	2 x 2/0
Input PE (AWG/kcmil)	10	10	10	8	8	6	6	6	2 x 4	2 x 4	2 x 3
Bypass/output phases (AWG/kcmil)	8	8	8	6	4	3	2	1/0	2 x 1/0	2 x 1/0	2 x 1/0
Bypass PE/output PE (AWG/kcmil)	10	10	10	10	8	8	6	6	2 x 6	2 x 4	2 x 4
Neutral (AWG/kcmil) <small>6</small>	8	8	6	3	1	2/0	2 x 1/0	2 x 1/0	2 x 2/0	4 x 1/0	4 x 1/0
DC +/- (AWG/kcmil)	10 ⁷	8 ⁷	4 ⁷	2 ⁷	1/0 ⁷	1/0 ⁸	2/0 ⁸	4/0 ⁸	2 x 1/0 ⁸	2 x 3/0 ⁸	2 x 4/0 ⁸
DC PE (AWG/kcmil)	10	10	8	6	6	6	6	4	4	3	2 x 2

NOTE: The DC cable sizes given here are recommendations – Always follow the specific instructions in the battery solution documentation for DC +/- and DC PE cable sizes.

NOTE: For 100 and 120 kW, use two separate conduits for each of the input, bypass, and output cable sets. Organize cables as illustrated in each conduit to avoid eddy currents (heating).

NOTE: For 150 kW, use two separate conduits for each of the input, bypass, output, and DC cable sets. Organize cables as illustrated in each conduit to avoid eddy currents (heating).

Cable Organization in Separate Conduits for Input/Bypass/Output and DC

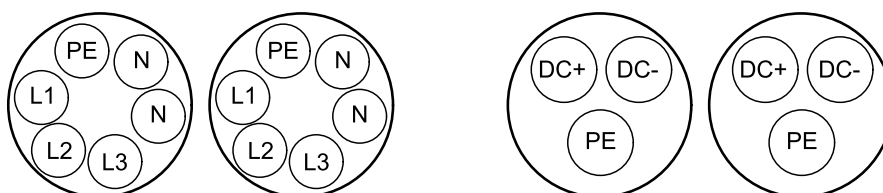

6. Neutral conductor is sized to handle 1.73 times phase current in case of high harmonic content from non-linear loads. If low or no harmonic currents are expected, neutral conductor can be sized as phase conductor.
 7. 20-40 kW: DC cables are sized according to 32 battery blocks.
 8. 50 kW and higher: DC cables are sized according to 40 battery blocks.

Recommended Bolt and Lug Sizes

NOTICE

RISK OF EQUIPMENT DAMAGE

Use only UL approved compression cable lugs.

Failure to follow these instructions can result in equipment damage.

Copper — One Hole Cable Lugs

Cable size	Bolt size	Cable lug type	Crimping tool	Die
10 AWG	M8 x 35 mm	LCA10-56-L	NA	NA
8 AWG	M8 x 35 mm	LCA8-56-L	CT-720	CD-720-1 Red P21
6 AWG	M8 x 35 mm	LCA6-56-L	CT-720	CD-720-1 Blue P24
4 AWG	M8 x 35 mm	LCA4-56-L	CT-720	CD-720-1 Gray P29
3 AWG	M8 x 35 mm	LCA4-56-L	CT-720	CD-720-1 Gray P29
2 AWG	M8 x 35 mm	LCA2-56-Q	CT-720	CD-720-1 Brown P33
1 AWG	M8 x 35 mm	LCA1-56-E	CT-720	CD-720-2 Green P37
1/0 AWG	M8 x 35 mm	LCA1/0-56-X	CT-720	CD-720-2 Pink P42
2/0 AWG	M8 x 35 mm	LCA2/0-56-X	CT-720	CD-720-2 Black P45
3/0 AWG	M8 x 35 mm	LCA3/0-56-X	CT-720	CD-720-2 Orange P50
4/0 AWG	M8 x 35 mm	LCA4/0-56-X	CT-720	CD-720-3 Purple P54

Copper — Two Hole Cable Lugs

Cable size	Bolt size	Cable lug type	Crimping tool	Die
6 AWG	M10 x 35 mm	LCC6-12-L	CT-930	CD-920-6 Blue P24
4 AWG	M10 x 35 mm	LCC4-12-L	CT-930	CD-920-4 Gray P29
3 AWG	M10 x 35 mm			
2 AWG	M10 x 35 mm	LCC2-12-Q	CT-930	CD-920-2 Brown P33
1 AWG	M10 x 35 mm	LCC1-12-E	CT-930	CD-920-1 Green P37
1/0 AWG	M10 x 35 mm	LCC1/0-12-X	CT-930	CD-920-1/0 Pink P42
2/0 AWG	M10 x 35 mm	LCC2/0-12-X	CT-930	CD-920-2/0 Black P45
3/0 AWG	M10 x 35 mm	LCC3/0-12-X	CT-930	CD-920-3/0 Orange P50
4/0 AWG	M10 x 35 mm	LCC4/0-12-X	CT-930	CD-920-4/0 Purple P54

Torque Specifications

Bolt size	Torque
M4	1.7 Nm (1.25 lb-ft / 15 lb-in)
M5	2.2 Nm (1.62 lb-ft / 19.5 lb-in)
M6	5 Nm (3.69 lb-ft / 44.3 lb-in)
M8	17.5 Nm (12.91 lb-ft / 154.9 lb-in)
M10	30 Nm (22 lb-ft / 194.7 lb-in)
M12	50 Nm (36.87 lb-ft / 442.5 lb-in)

Maintenance Bypass Cabinet Weights and Dimensions

Commercial reference	Weight kg (lbs)	Height mm (in)	Width mm (in)	Depth mm (in)
GVSBPUSU80G	110 (243)	1485 (58.46)	318 (12.52)	850 (33.46)
GVSBPUSU150G	120 (265)	1485 (58.46)	318 (12.52)	850 (33.46)

Clearance

NOTE: Clearance dimensions are published for airflow and service access only. Consult with the local safety codes and standards for additional requirements in your local area.

Front View of the UPS and the Maintenance Bypass Cabinet

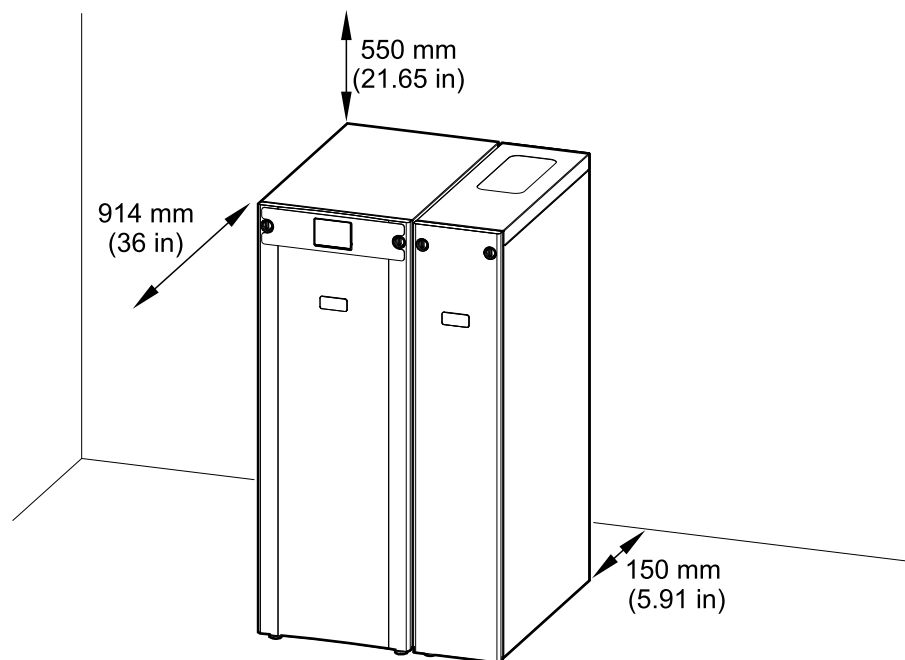

Environment

	Operating	Storage
Temperature	0 °C to 40 °C (32 °F to 104 °F)	-25 °C to 55 °C (-13 °F to 131 °F)
Relative humidity	5-95% non-condensing	10-80% non-condensing
Elevation	0-3000 m (0-10000 feet)	
Protection class	IP20	
Color	RAL 9003, gloss level 85%	

System Overview

UIB	Unit input breaker
SSIB	Static switch input breaker
MBB	Maintenance bypass breaker
IMB	Internal maintenance breaker
UOB	Unit output breaker

NOTE: The internal maintenance breaker IMB* in the UPS cannot be used with a maintenance bypass cabinet and the internal maintenance breaker IMB* must be padlocked in the open position.

Single Mains UPS System

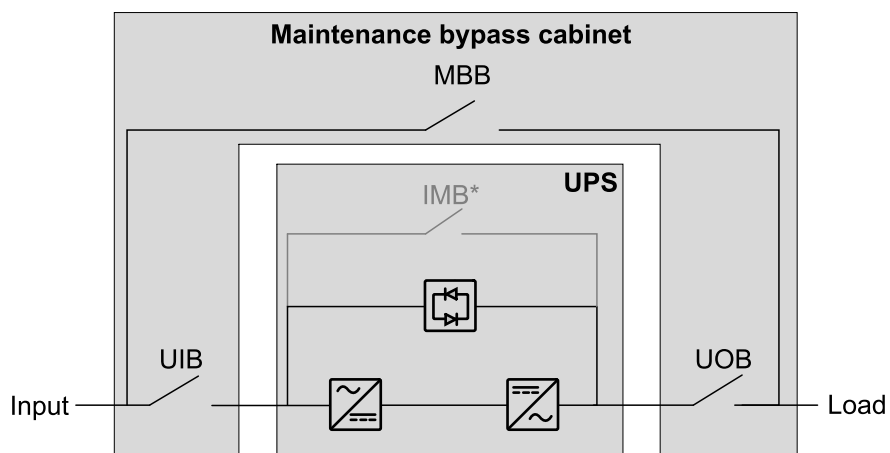

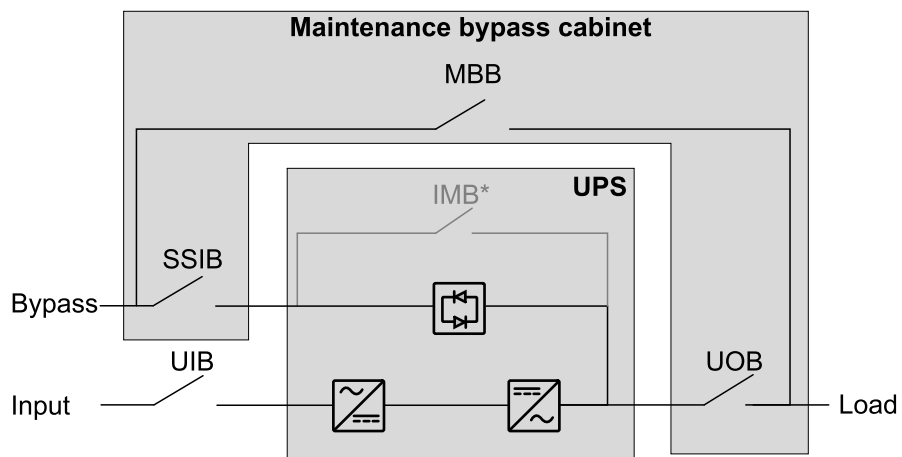

Dual Mains UPS System





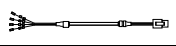
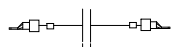
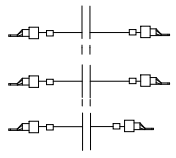
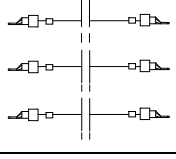
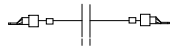

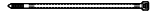



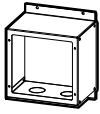

Overview of Installation Kits

Installation Kit 0M-100265 for 10-80 kW Maintenance Bypass Cabinet





Part	Used in	Number of units
0W49284 signal cable	Connect the Signal Cables, page 51.	1 
0W49283 signal cable		1 
0W99053 UPS PE cable	Connect the Power Cables in a 10-80 kW Top Cable Entry System, page 39 or Connect the Power Cables in a Bottom Cable Entry System, page 45.	1 
0W99055 UPS output cables		1 
0W99056 UPS input/UPS bypass cables		1 
0W99054 UPS neutral cable		1 
M8 nut with washer		10 
M8 x 25 mm bolt with washer		10 
Cable ties		10 

Installation Kit 0H-1717

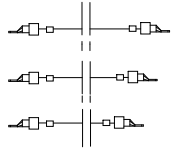

Only for installation with UPS for internal batteries.

Part	Used in	Number of units
Conduit box	Install the Conduit Box, page 34	1 
Rear plate		1 
UPS input/UPS bypass cables 0W12758		1 
UPS output cables 0W12761		1 
M4 x 10 mm screw with washer		4 
M8 nut with washer		3 
M8 x 25 mm bolt with washer		3 
M6 x 16 mm screw with washer		9 
M6 nut with washer		9 
Support for side panel		Prepare the Maintenance Bypass Cabinet and the UPS for Cables, page 31 10 



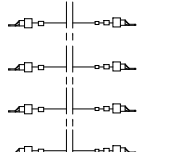

Installation Kit 0M-100247 for 100-150 kW Maintenance Bypass Cabinet

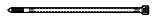
Part	Used in	Number of units
0W49195 UPS input cables (for dual mains)	Connect the Power Cables in a 100-150 kW Top Cable Entry System, page 41.	1 
M8 nut with washer		6 
M8 x 25 mm bolt with washer		6 
Cable ties		10 



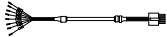

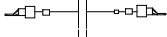
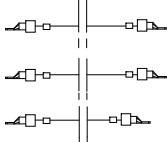
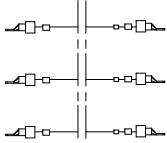
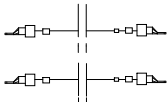
Installation Kit 0M-100250 for 100-150 kW Maintenance Bypass Cabinet

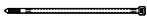
Part	Used in	Number of units
0W49194 UPS DC cables	Connect the Power Cables in a 100-150 kW Top Cable Entry System, page 41	1 
M8 nut with washer		6 
M8 x 25 mm bolt with washer		6 
Cable ties		10 









Installation Kit 0M-100264 for 100-150 kW Maintenance Bypass Cabinet

Part	Used in	Number of units
0W49284 signal cable	Connect the Signal Cables, page 51.	1 
0W49283 signal cable		1 
0W99057 UPS PE cable	Connect the Power Cables in a 100-150 kW Top Cable Entry System, page 41, or Connect the Power Cables in a Bottom Cable Entry System, page 45.	1 
0W12375 UPS output cables		1 
0W99058 UPS input/UPS bypass cables		1 
0W99052 UPS neutral cable		1 
M8 nut with washer		11 
M8 x 25 mm bolt with washer	11 	
Cable ties	10 	

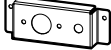
Optional Seismic Kit GVSOPT003

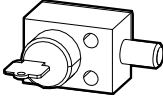
Part	Used in	Number of units
Rear anchor	Install the Seismic Anchoring (Option), page 37 and Final Installation, page 54.	1 
Front anchoring bracket		1 
Rear anchoring bracket		1 
M8 x 20 mm bolt		6 

Optional Kirk Key Kit GVSOPT004

Part	Used in	Number of units
Support plate	The optional kirk key kit must be installed by a Schneider Electric field service representative. Contact Schneider Electric.	2 
Flathead screw		8 
Push-button		1 
Top support plate		1 
Electromechanical key interlock (SKRU)		1 
Mechanical key interlock		2 
Label		1 <div data-bbox="1295 1111 1458 1167" style="border: 1px solid black; padding: 2px; width: fit-content;">Push this button to release the key</div>
M6 nut with washer		2 
0W12675 signal cable		1 
0W49239 signal cable		1 

Installation Procedure for Top Cable Entry

Installation without Conduit Box – Single Mains

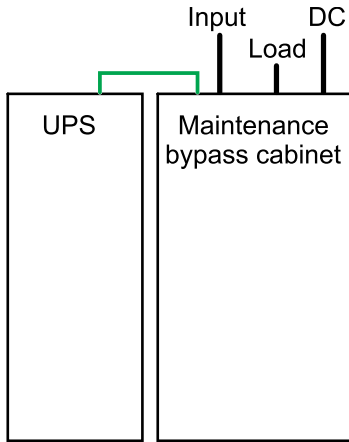

Installation with Conduit Box – Single Mains

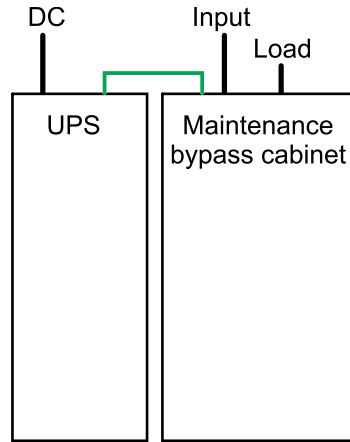

Installation without Conduit Box – Dual Mains

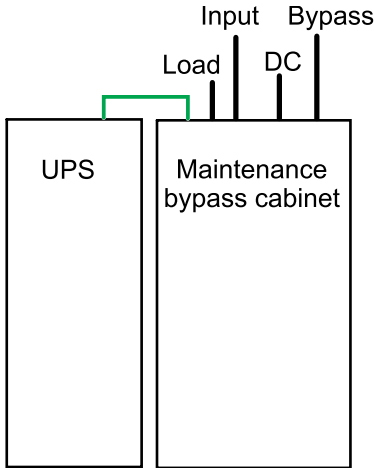

Installation with Conduit Box – Dual Mains

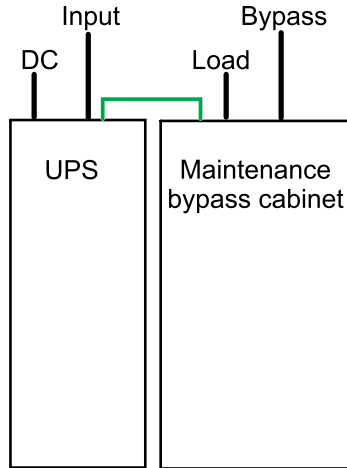

— Signal cable
 — Power cable

⚠ WARNING

TIP HAZARD

Do not remove the transportation brackets from the maintenance bypass cabinet until it is time to anchor it to the floor or interconnect it with the UPS.

Failure to follow these instructions can result in death, serious injury, or equipment damage.

1. Follow the UPS manual to prepare the UPS for installation.
2. Prepare the Maintenance Bypass Cabinet and the UPS for Cables, page 31.
3. For system with conduit box: Install the Conduit Box, page 34
4. Connect the Internal Power Cables, page 35.
5. Install the Seismic Anchoring (Option), page 37.

6. Perform one of the following:
 - Connect the Power Cables in a 10-80 kW Top Cable Entry System, page 39, or
 - Connect the Power Cables in a 100-150 kW Top Cable Entry System, page 41.
7. Interconnect the UPS and the Maintenance Bypass Cabinet, page 46.
8. Connect the Signal Cables, page 51.
9. Final Installation, page 54.
10. Follow the UPS installation manual to connect the power cables from the maintenance bypass cabinet in the UPS and to complete the rest of the UPS installation.

For moving or decommissioning the maintenance bypass cabinet after installation has been completed, see [Decommission or Move the Maintenance Bypass Cabinet to a New Location](#), page 57.

Installation Procedure for Bottom Cable Entry

Single Mains

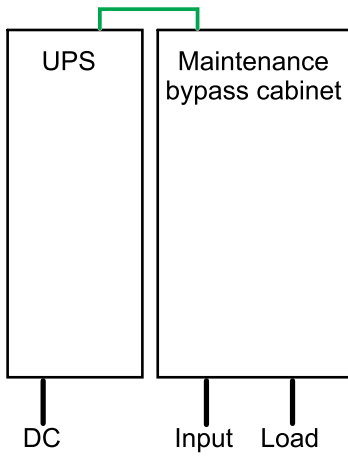

Dual Mains

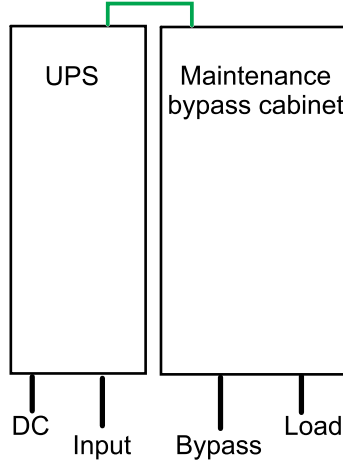

— Signal cable
 — Power cable

⚠ WARNING

TIP HAZARD

Do not remove the transportation brackets from the maintenance bypass cabinet until it is time to anchor it to the floor or interconnect it with the UPS.

Failure to follow these instructions can result in death, serious injury, or equipment damage.

1. Follow the UPS manual to prepare the UPS for installation.
2. Prepare the Maintenance Bypass Cabinet and the UPS for Cables, page 31.
3. For system with conduit box: Install the Conduit Box, page 34
4. Connect the Internal Power Cables, page 35.
5. Install the Seismic Anchoring (Option), page 37.
6. Connect the Power Cables in a Bottom Cable Entry System, page 45.
7. Interconnect the UPS and the Maintenance Bypass Cabinet, page 46.
8. Connect the Signal Cables, page 51.
9. Final Installation, page 54.
10. Follow the UPS installation manual to connect the power cables from the maintenance bypass cabinet in the UPS and to complete the rest of the UPS installation.

For moving or decommissioning the maintenance bypass cabinet after installation has been completed, see Decommission or Move the Maintenance Bypass Cabinet to a New Location, page 57.

Prepare the Maintenance Bypass Cabinet and the UPS for Cables

⚠ DANGER

HAZARD OF ELECTRIC SHOCK, EXPLOSION, OR ARC FLASH

Do not drill or cut holes for power cables or conduits with the gland plate installed and do not drill or cut holes in close proximity to the maintenance bypass cabinet.

Failure to follow these instructions will result in death or serious injury.

1. Remove the front panel from the maintenance bypass cabinet.

Front View of the Maintenance Bypass Cabinet

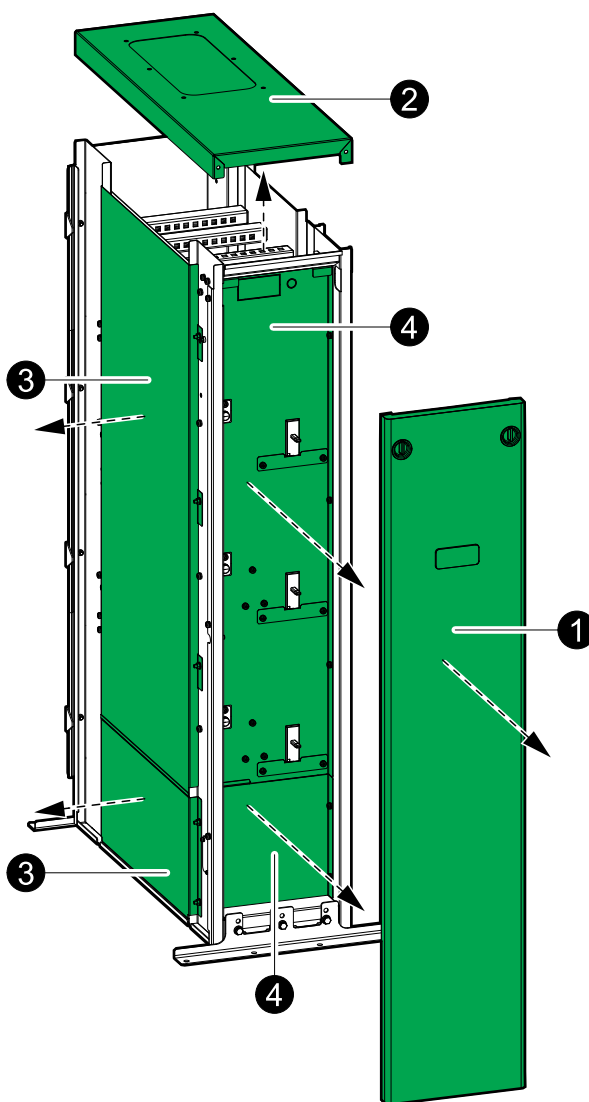

2. Remove the top cover from the maintenance bypass cabinet.
3. Remove the upper and lower left side plate from the maintenance bypass cabinet.
4. Remove the lower and upper front plate from the maintenance bypass cabinet.

5. Remove the transparent plate above the top breaker.

Front View of the Maintenance Bypass Cabinet

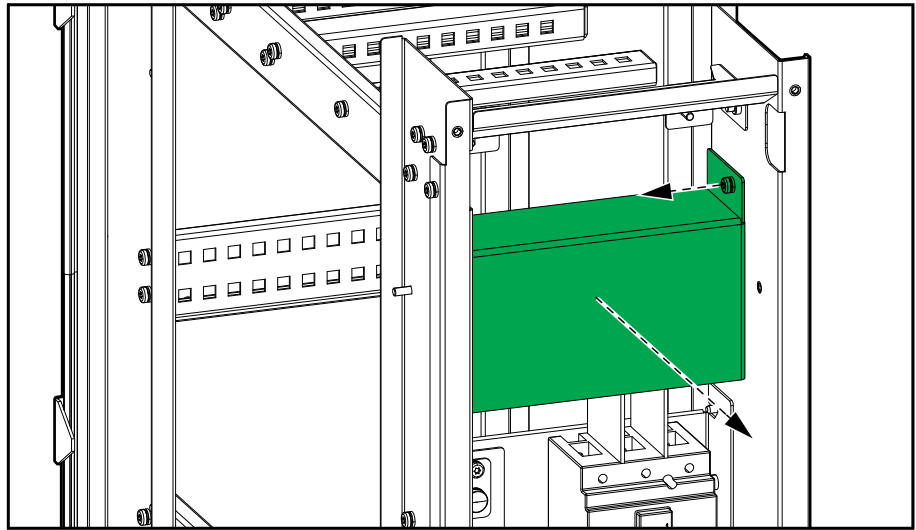

6. **Only for bottom cable entry in 100-150 kW maintenance bypass cabinet:** Remove the indicated busbars and insulators in the maintenance bypass cabinet for more cable routing space.

Left Side View of the 100-150 kW Maintenance Bypass Cabinet

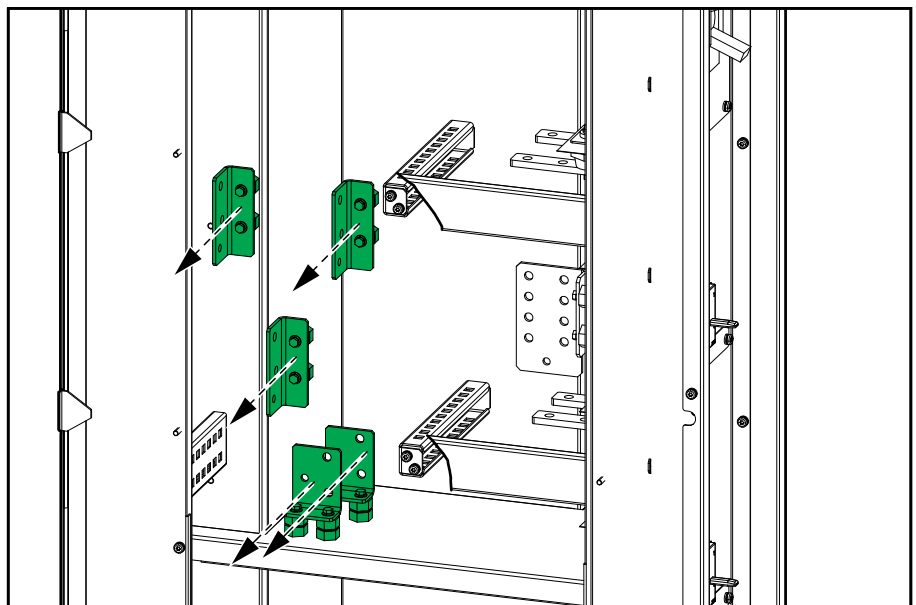

7. Remove the right side panel from the UPS and reinstall the side panel on the right side of the maintenance bypass cabinet. For installation with a UPS for internal batteries, install the 10 supports (A) from installation kit 0H-1717. Reuse the screws from the UPS.

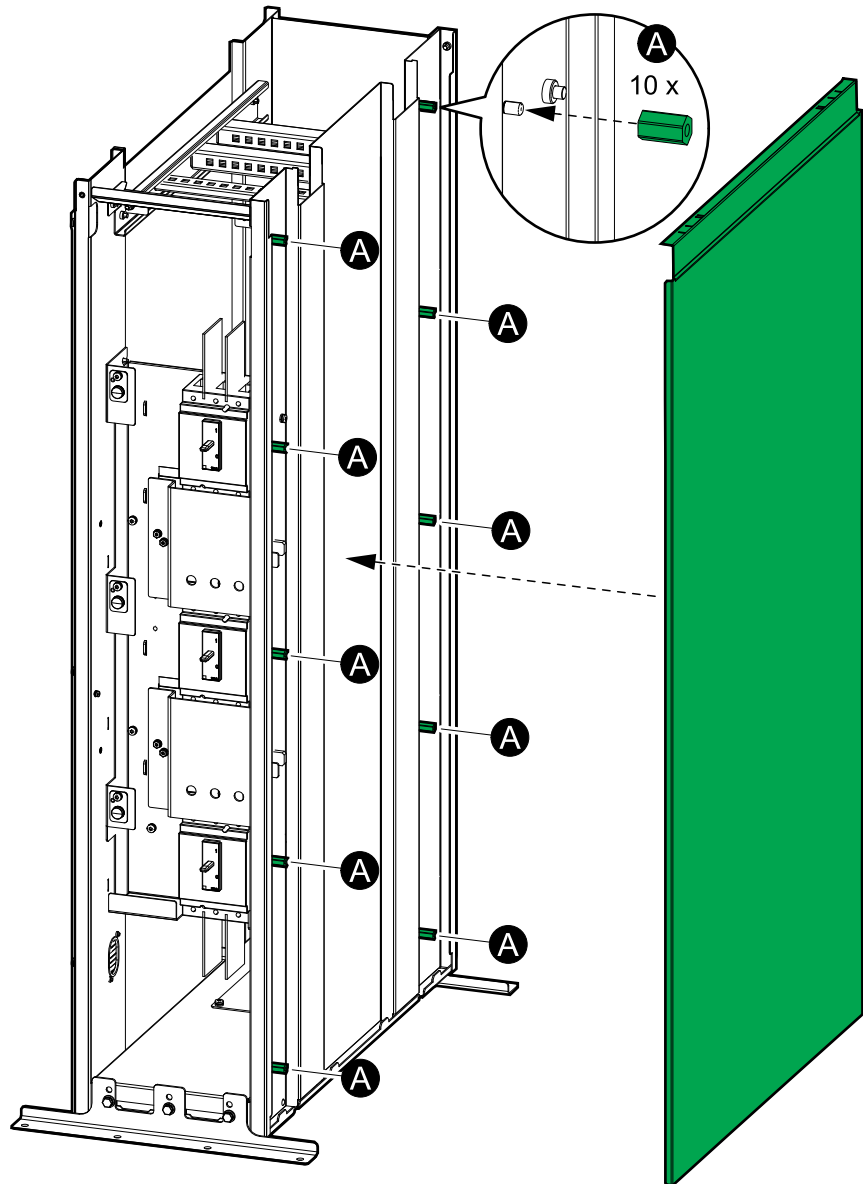

8. Only for top cable entry system:

- a. Remove the gland plate from the top cover of the maintenance bypass cabinet.
- b. Drill or punch holes for power cables or conduits in the gland plate. Conduits are not provided.
- c. Reinstall the gland plate in the top cover of the maintenance bypass cabinet.

9. Only for bottom cable entry system:

- a. Remove the gland plate from the bottom of the maintenance bypass cabinet.
- b. Drill or punch holes for power cables or conduits in the gland plate. Conduits are not provided.
- c. Reinstall the gland plate in the bottom of the maintenance bypass cabinet.

10. Reinstall the top cover on the maintenance bypass cabinet with four screws.

Install the Conduit Box

1. Remove the middle rear plate on the maintenance bypass cabinet. Save the nuts for installing the conduit box.
2. Remove the knockouts from the conduit box.
3. Install the conduit box on the maintenance bypass cabinet with the nuts from step 1.
4. Install the provided UPS input/UPS bypass cables 0W12758 and UPS output cables 0W12761 in the conduit box.
5. Install the rear plate on the conduit box

Rear View of the Maintenance Bypass Cabinet

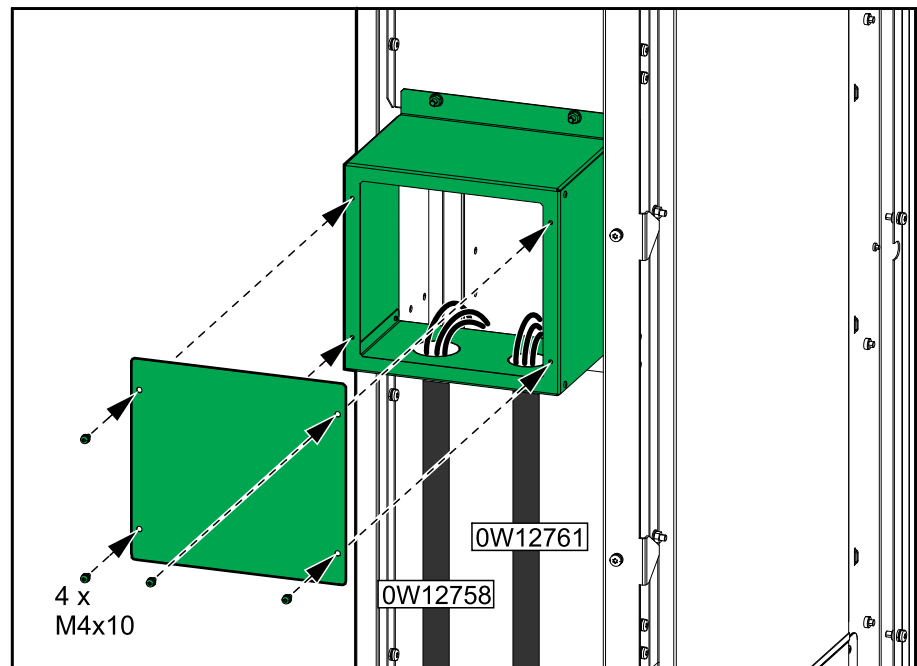

Connect the Internal Power Cables

Fasten the cables to the beam with a cable tie where marked with an (A) in the illustrations.

1. Connect the provided UPS PE cable to the PE busbar and route the cable out through the left side or through the rear of the maintenance bypass cabinet.
2. Connect the provided UPS N cable to the N busbar and route the cable out through the left side or through the rear of the maintenance bypass cabinet.

Left Side View of the Maintenance Bypass Cabinet without Conduit Box

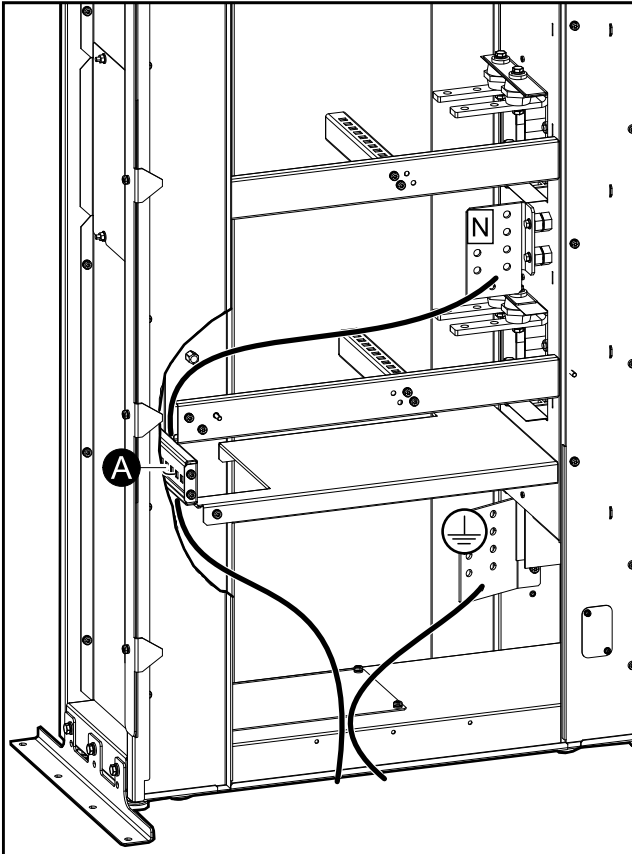

Left Side View of the Maintenance Bypass Cabinet with Conduit Box

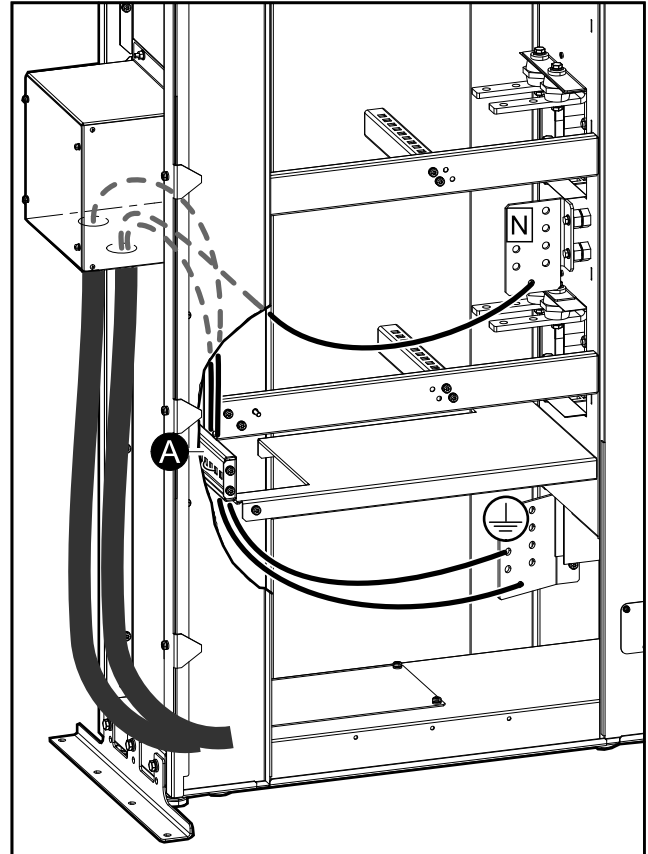

3. Perform one of the following:
 - **Only for single mains system:** Connect the provided UPS input cables to the unit input breaker UIB (L1, L2, L3) and route the cables out through the left side or through the rear of the maintenance bypass cabinet.
 - **Only for dual mains system:** Connect the provided UPS bypass cables to the static switch input breaker SSIB (L1, L2, L3) and route the cables out through the left side or through the rear of the maintenance bypass cabinet.

Maintenance Bypass Cabinet without Conduit Box Maintenance Bypass Cabinet with Conduit Box

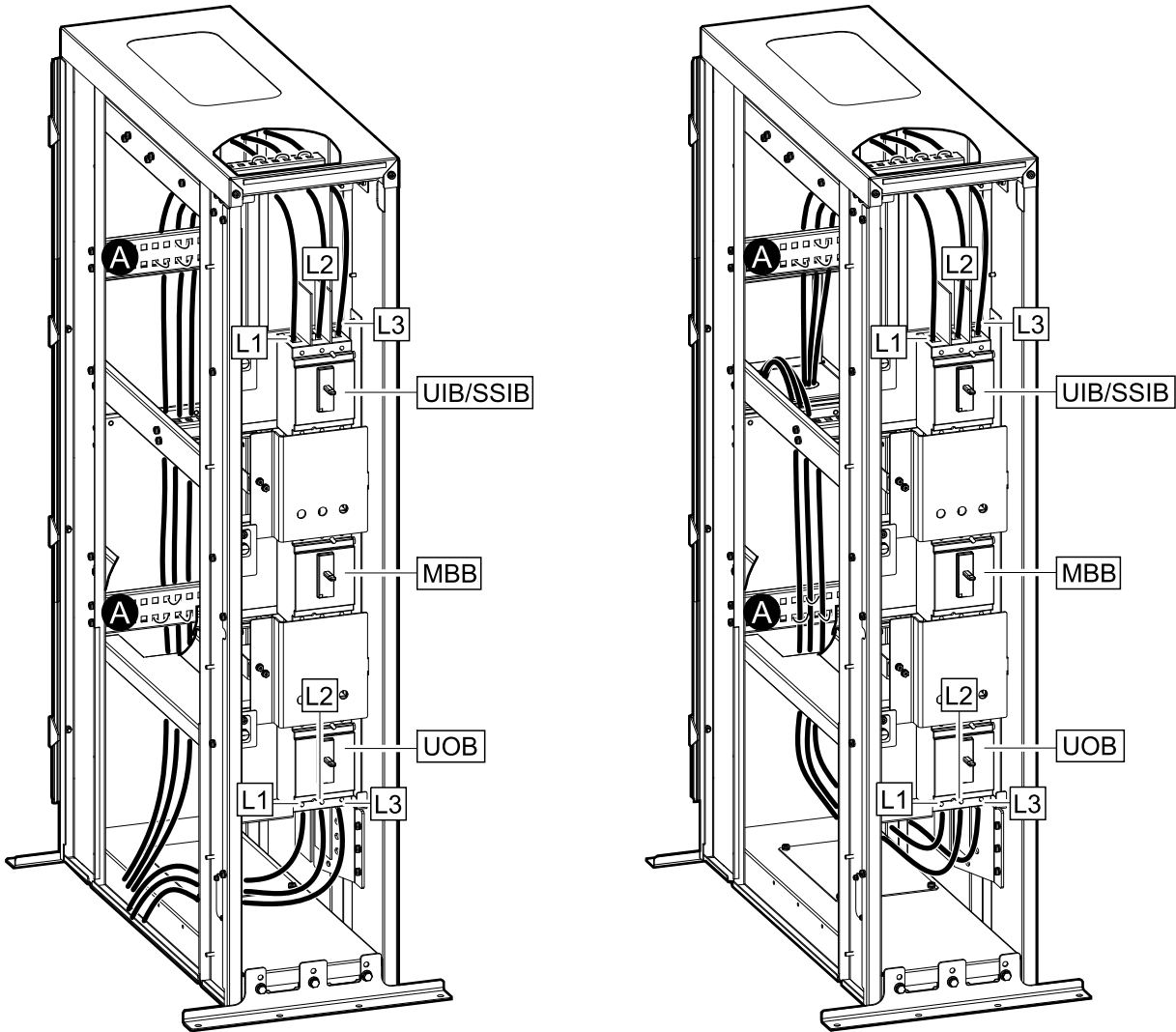

4. Connect the provided UPS output cables to the unit output breaker UOB (L1, L2, L3) and route the cables out through the left side or through the rear of the maintenance bypass cabinet.

Install the Seismic Anchoring (Option)

Use the optional installation kits GVSOPT002 (shipped with the UPS) and GVSOPT003 for this procedure.

1. Interconnect the rear anchors for the UPS (on the left) and the maintenance bypass cabinet (on the right) with the interconnection plate and four M8 bolts (provided).
2. Mount the rear anchor(s) to the floor. Use appropriate hardware for the floor type – the hole diameter in the rear anchor is $\varnothing 14$ mm.

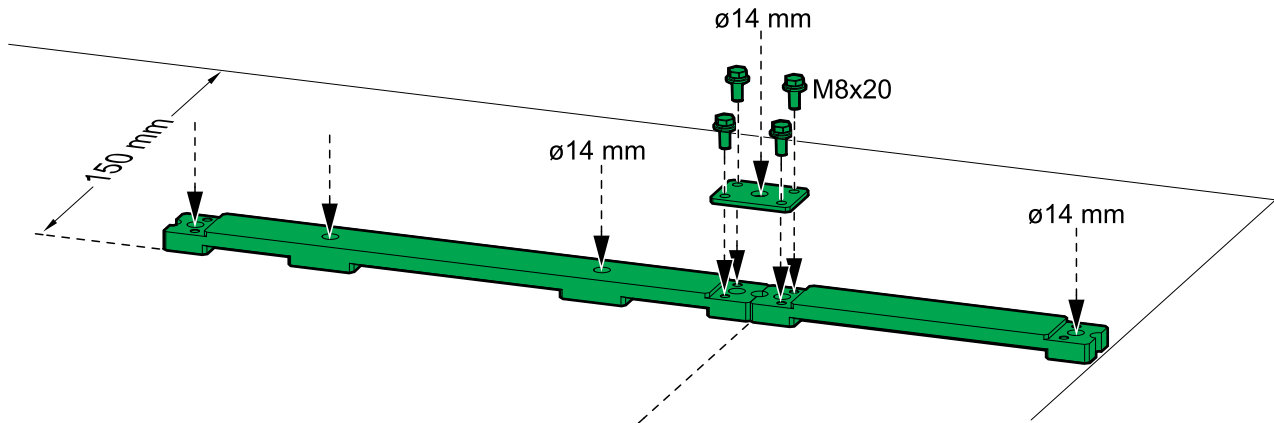

3. Remove the transportation brackets from the maintenance bypass cabinet.
4. Install the rear anchoring brackets on the UPS and the maintenance bypass cabinet with the M8 bolts (provided).

Rear View of the Maintenance Bypass Cabinet

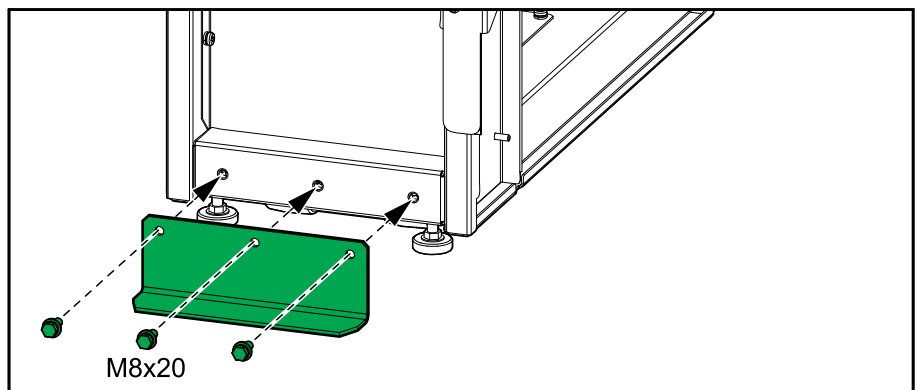

5. Push the maintenance bypass cabinet into position so the rear anchoring bracket connects to the rear anchor. The front anchoring bracket is installed in the final installation steps.

NOTE: Do not push the UPS into position yet.

Rear View of the Maintenance Bypass Cabinet

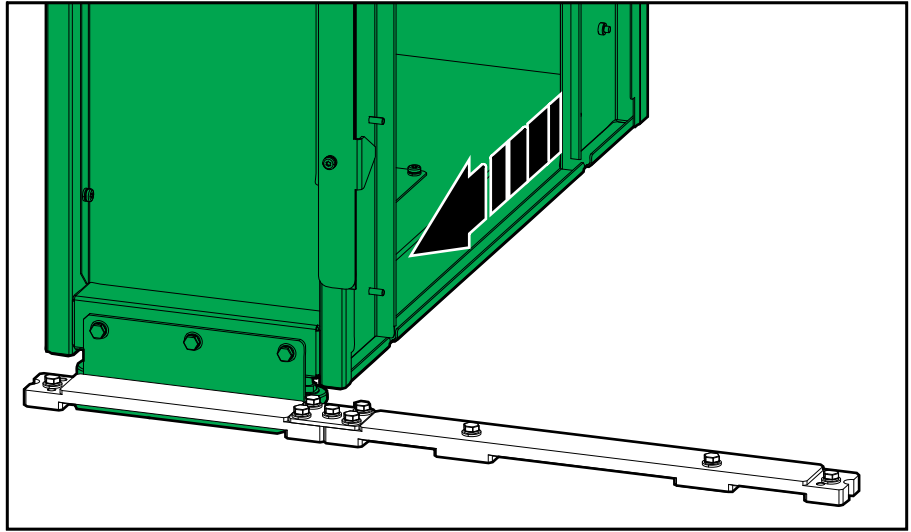

Connect the Power Cables in a 10-80 kW Top Cable Entry System

1. The power cables must be restrained with 3/8 nylon rope:
 - a. Tie the power cables to the beams with rope as illustrated. Make sure that the rope holds the cables tightly in place. Note that L2 is routed under the beam and L1 and L3 is routed over the beam in front of the busbars.
 - b. Tie the power cables together with rope as illustrated halfway between the two beams. See *Restrain the Cables*, page 43 for restrain method.

Left Side View of the Maintenance Bypass Cabinet – Single Mains

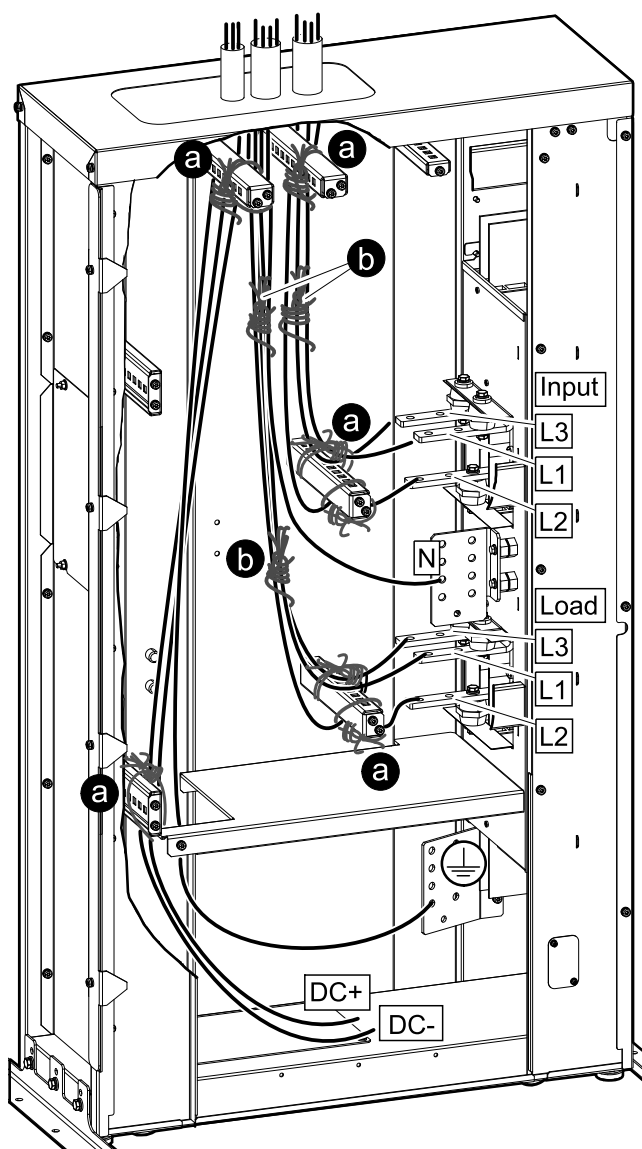

Left Side View of the Maintenance Bypass Cabinet – Dual Mains

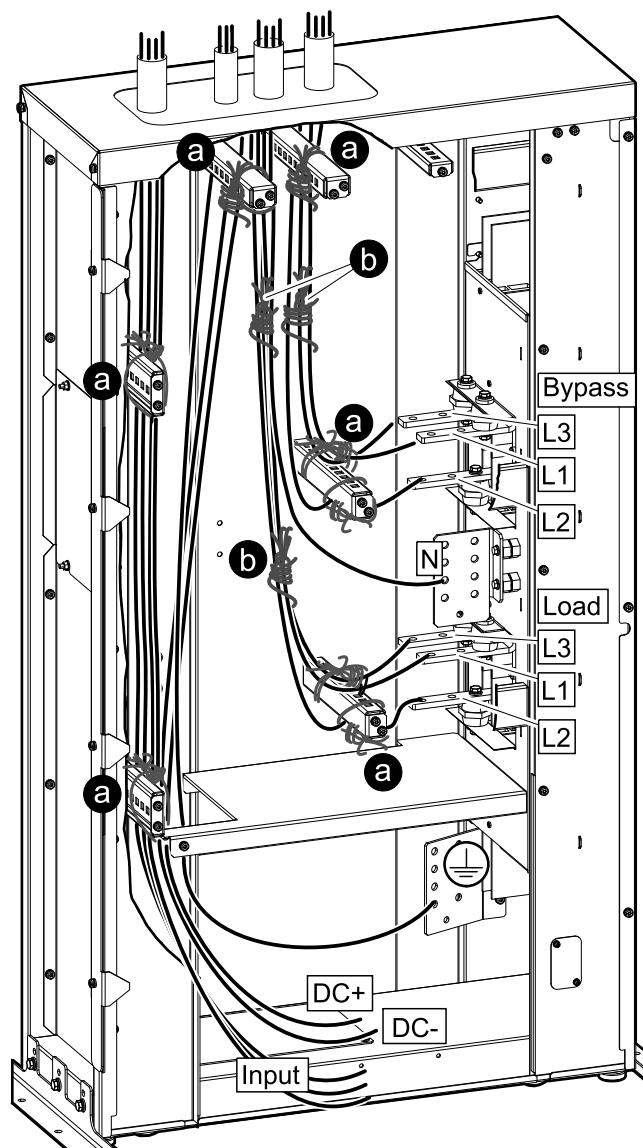

2. Perform one of the following:
 - **Only for single mains system:** Route the input cables and load cables through the top of the maintenance bypass cabinet and connect to the PE busbar, the input busbars, and the load busbars.
 - **Only for dual mains system:** Route the bypass cables and load cables through the top of the maintenance bypass cabinet and connect to the PE busbar, bypass busbars, and the load busbars.
3. **Only for dual mains system:**
 - **For top cable entry without conduit box:** Route the input cables through the top of the maintenance bypass cabinet and to the bottom of the maintenance bypass cabinet. When the UPS has been installed, route the input cables through the left side into the UPS. Follow the UPS installation manual to connect the input cables.
 - **For top cable entry with conduit box:** When the UPS has been installed, route the input cables through the conduit box of the UPS. Follow the UPS installation manual to connect the input cables.
4. Perform one of the following:
 - **For top cable entry without conduit box:** Route the DC cables through the top of the maintenance bypass cabinet and to the bottom of the maintenance bypass cabinet. When the UPS has been installed, route the DC cables through the left side into the UPS. Follow the UPS installation manual to connect the DC cables.
 - **For top cable entry with conduit box:** When the UPS has been installed, route the DC cables through the conduit box of the UPS. Follow the UPS installation manual to connect the DC cables.

Connect the Power Cables in a 100-150 kW Top Cable Entry System

1. The power cables must be restrained with 3/8 nylon rope:
 - a. Tie the power cables to the beams with rope as illustrated. Make sure that the rope holds the cables tightly in place. Note that L2 is routed under the beam and L1 and L3 is routed over the beam in front of the busbars.
 - b. Tie the power cables together with rope as illustrated halfway between the two beams. See *Restrain the Cables*, page 43 for restrain method.

Left Side View of the Maintenance Bypass Cabinet – Single Mains

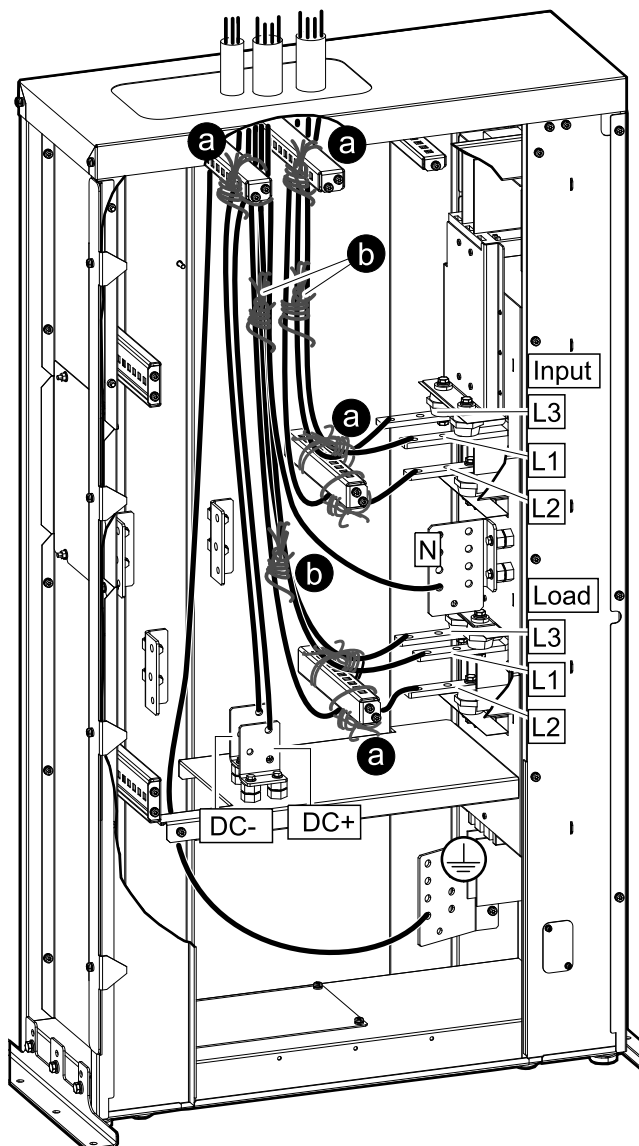

Left Side View of the Maintenance Bypass Cabinet – Dual Mains

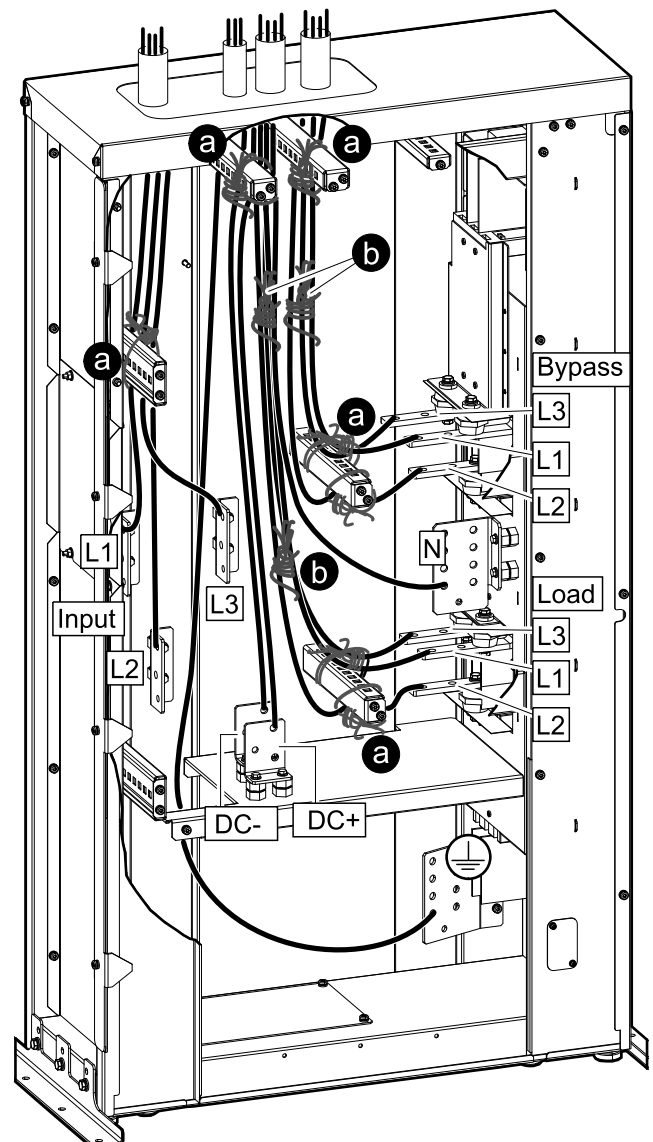

2. Perform one of the following:
 - **Only for single mains system:** Route the input cables and the load cables through the top of the maintenance bypass cabinet and connect to the PE busbar, the input busbars and the load busbars.
 - **Only for dual mains system:** Route the input cables, the bypass cables and the load cables through the top of the maintenance bypass cabinet and connect to the PE busbar, the input busbars, the bypass busbars, and the load busbars.
3. Route the DC cables through the top of the maintenance bypass cabinet and connect to the PE busbar and the DC busbars (DC+, DC-).
4. Connect the provided UPS DC cables to the DC busbars (DC+, DC-) and route the cables out through the left side of the maintenance bypass cabinet. Fasten the cables to the beam with cable ties.
5. **Only for dual mains system:** Connect the provided UPS input cables to the input busbars and route the cables out through the left side of the maintenance bypass cabinet. Fasten the cables to the beam with cable ties.

Left Side View of the Maintenance Bypass Cabinet

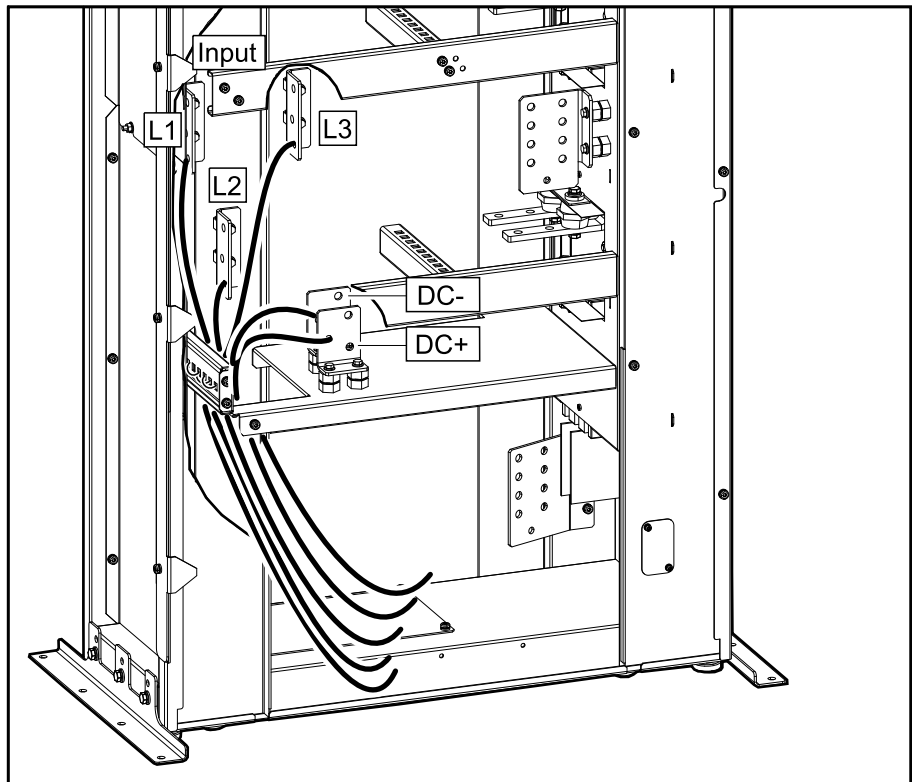

Restrain the Cables

Use 3/8 in nylon rope to restrain the cables.

1. Wrap the rope around the cables (a). Wrap the cables four times leaving 1 m (3 ft) of excess rope at the first end (b). Pull rope (c) taut.

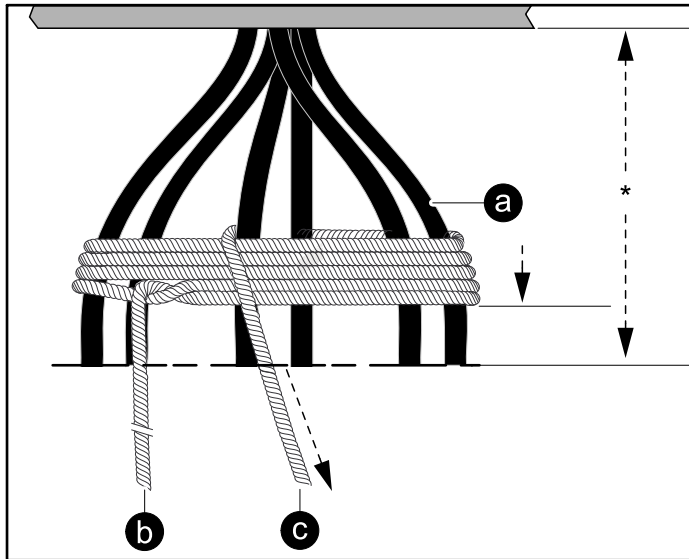

* Unsupported cable length.

2. Wrap rope (a) several times until the space between the first two sets of cables is completely filled. Weave final rope loop underneath the previous loop (b). Bring rope (c) through the other open area and pull the rope taut.

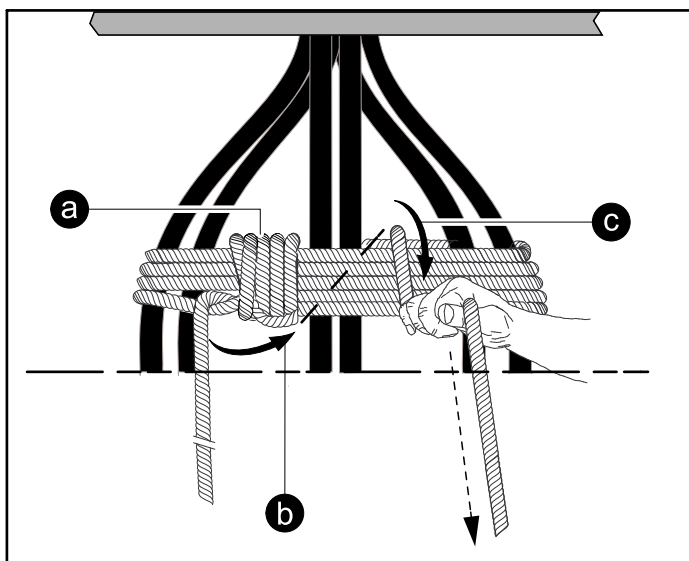

3. Wrap rope (a) several times until the space between the second and the third set of cables is completely filled. Wave the final rope loop (b) underneath the previous loop as shown. Pull the rope taut.

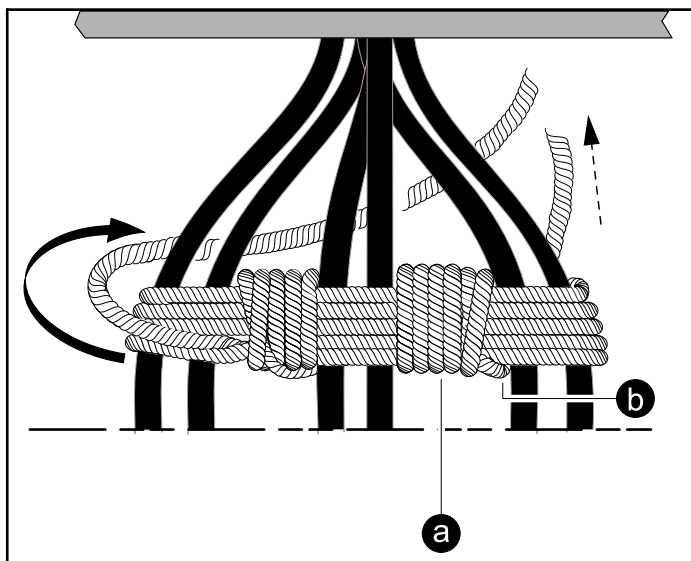

4. Tie rope End 1 and End 2 together as shown. The rope must be taut. Cut off excess rope and tape ends to prevent fraying.

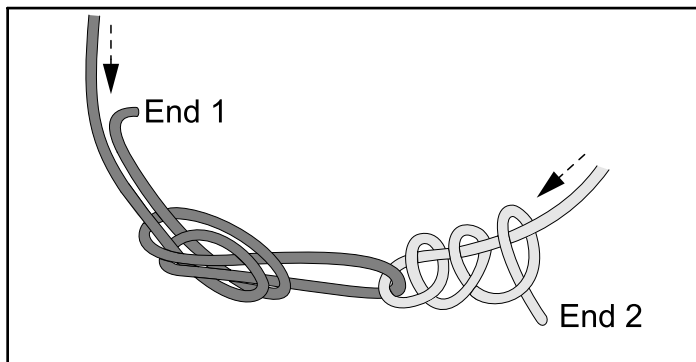

5. Repeat the procedure where needed.

Connect the Power Cables in a Bottom Cable Entry System

NOTE: DC cables are routed through the bottom or through the conduit box of the UPS. Follow the UPS installation manual to install the DC cables.

NOTE: Input cables in dual mains systems are routed through the bottom or through the conduit box of the UPS. Follow the UPS installation manual to install the input cables.

1. Perform one of the following:
 - **Only for single mains system:** Route the input cables and the load cables through the bottom of the maintenance bypass cabinet and connect to the PE busbar, the input busbars, and the load busbars.
 - **Only for dual mains system:** Route the bypass cables and the load cables through the bottom of the maintenance bypass cabinet and connect to the PE busbar, the bypass busbars, and the load busbars.
2. The power cables must be restrained with 3/8 nylon rope:
 - a. Tie the power cables to the beams with rope as illustrated. Make sure that the rope holds the cables tightly in place. Note that L2 is routed under the beam and L1 and L3 is routed over the beam in front of the busbars.

Left Side View of the Maintenance Bypass Cabinet – Single Mains

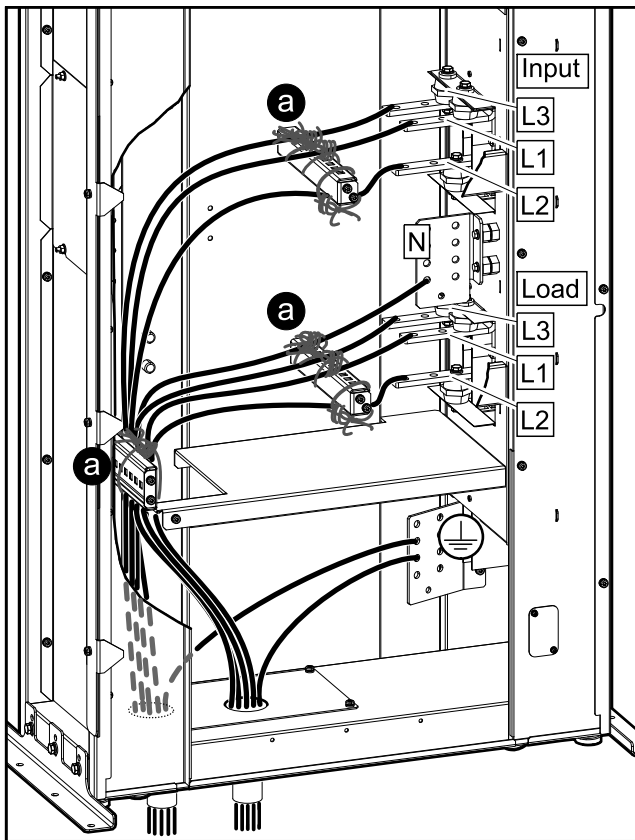

Left Side View of the Maintenance Bypass Cabinet – Dual Mains

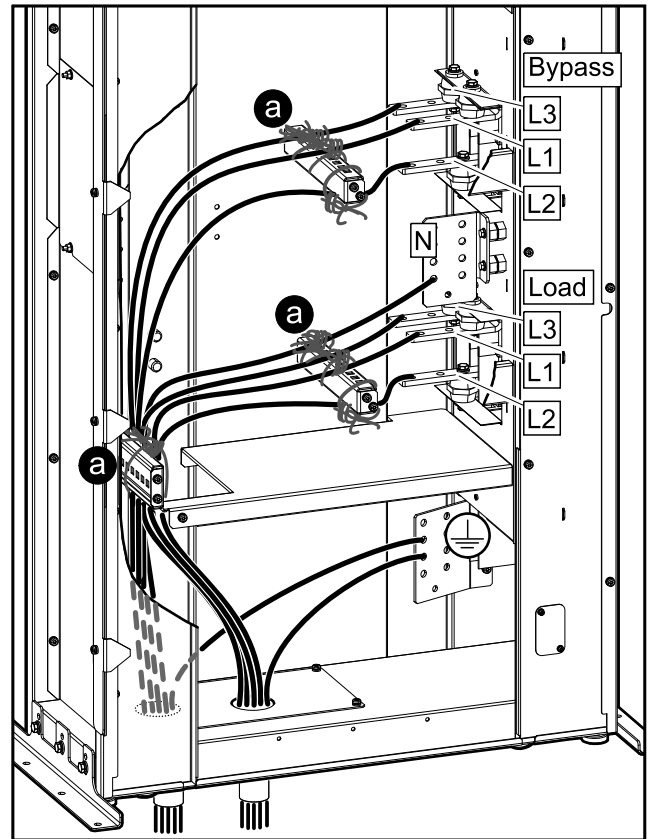

Interconnect the UPS and the Maintenance Bypass Cabinet

1. Reinstall the left upper side plate and the transparent plate on the maintenance bypass cabinet.

Left Side View of the Maintenance Bypass Cabinet

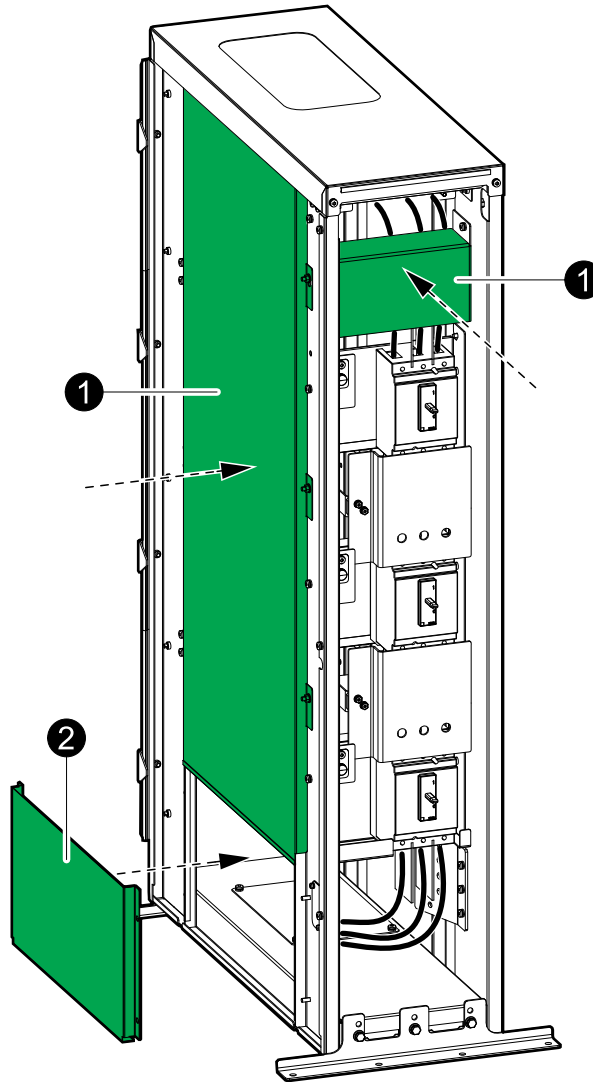

2. **Only with conduit box:** Reinstall the left lower side plate.
3. Remove the transportation brackets from the maintenance bypass cabinet, if not already removed for seismic anchoring.

4. Remove the three interconnection screws from the left side of the maintenance bypass cabinet. Save for interconnection.

Front View of the UPS and the Maintenance Bypass Cabinet

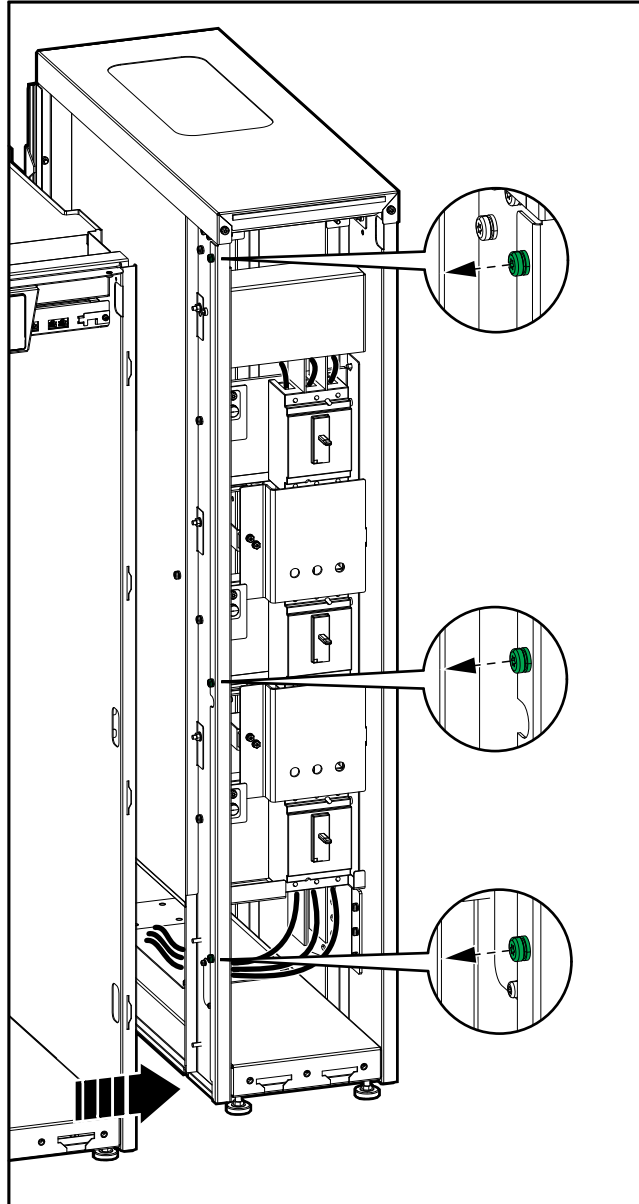

5. Position the UPS close to the maintenance bypass cabinet with a little free space between the cabinets.

6. Push the UPS into place up against the maintenance bypass cabinet. The rear bracket on the maintenance bypass cabinet must connect to the UPS.

Rear View of the Maintenance Bypass Cabinet and the UPS

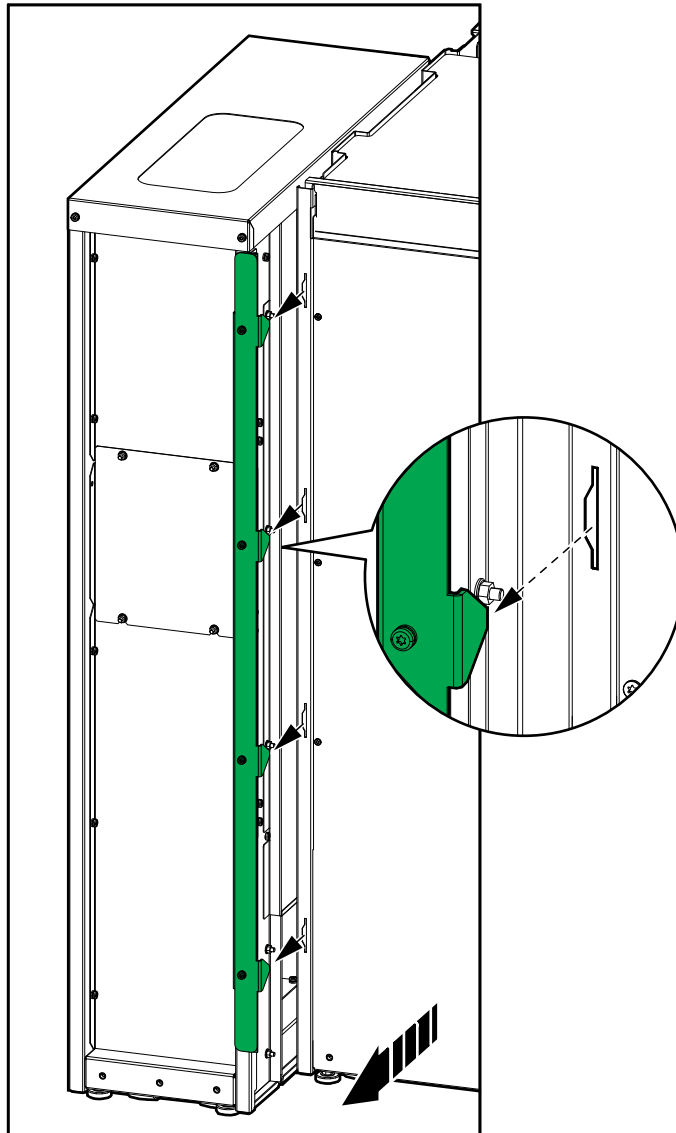

7. Install the three interconnection screws between the UPS and the maintenance bypass cabinet as shown.

Front View of the UPS and the Maintenance Bypass Cabinet

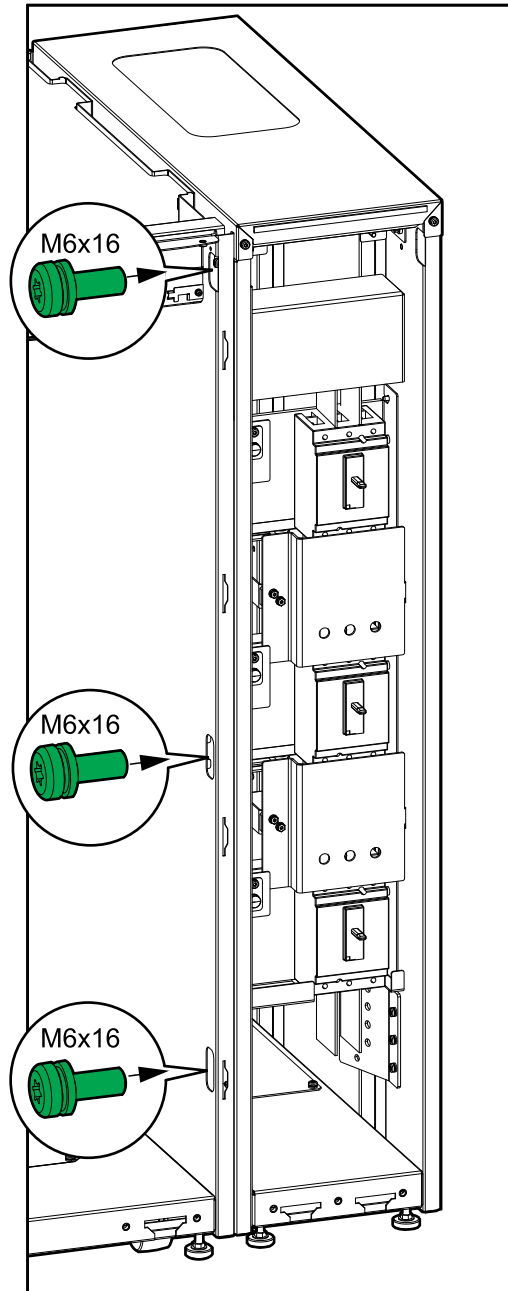

- Lower the front and rear leveling feet on the UPS and the maintenance bypass cabinet with a wrench until they connect with the floor. Use a bubble-leveler to check that the UPS and maintenance bypass cabinet are level.

Front View of the UPS

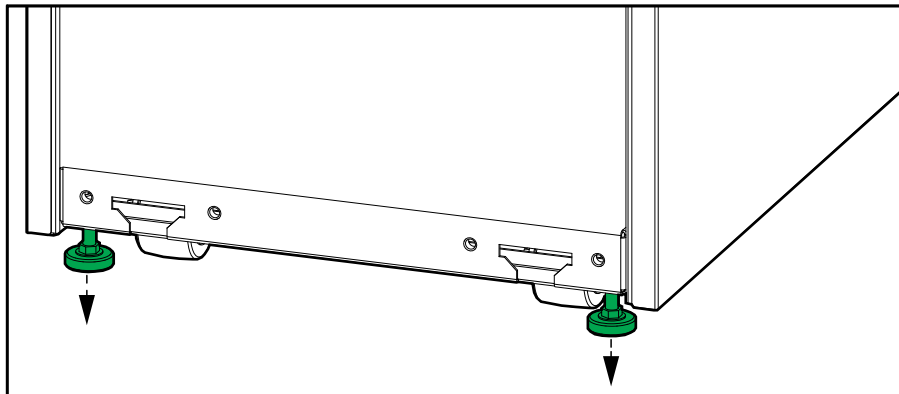

▲ CAUTION

RISK OF EQUIPMENT DAMAGE

Do not move the cabinet after the leveling feet have been lowered.

Failure to follow these instructions can result in injury or equipment damage.

Connect the Signal Cables

1. Connect the provided Class 2/SELV signal cable 0W49283 to board 640-4864 in the UPS as shown.

Single Mains System

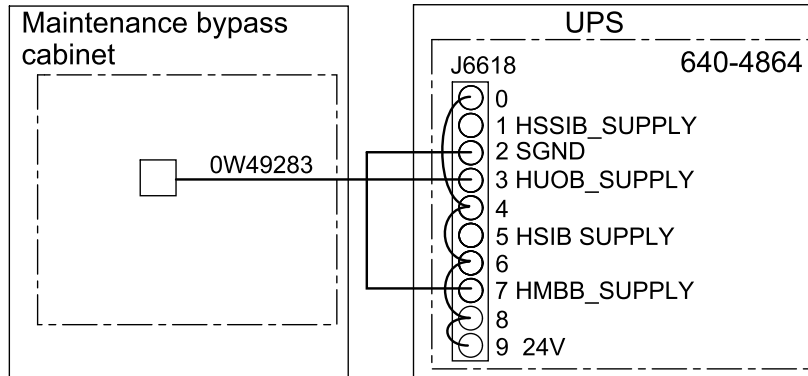

Dual Mains System

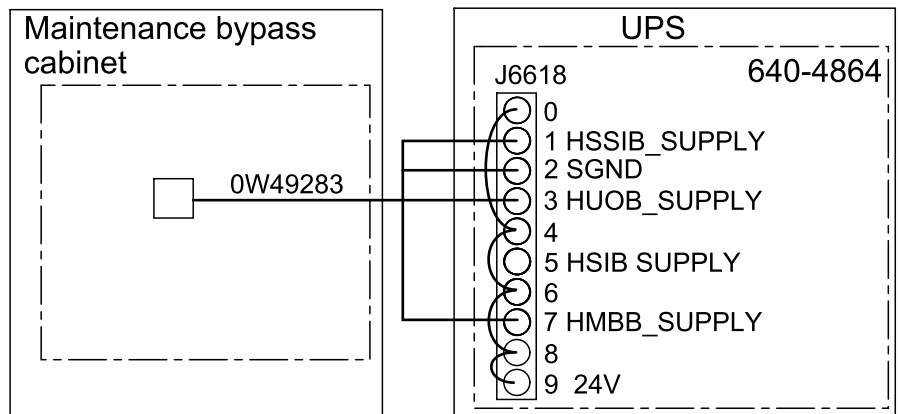

2. Connect the non-Class 2/non-SELV signal cable 0W49284 to board 640-4843 in the UPS as shown.

Single Mains System

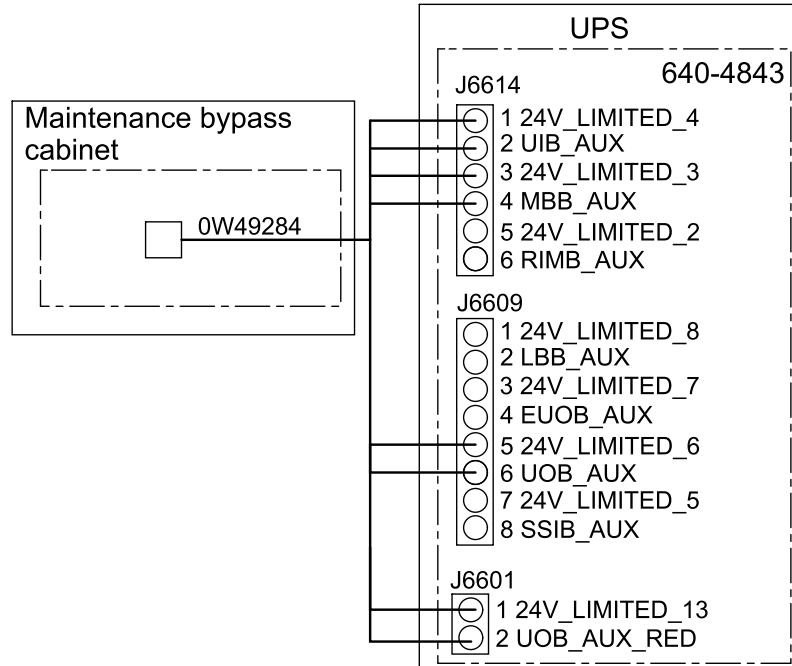

Dual Mains System

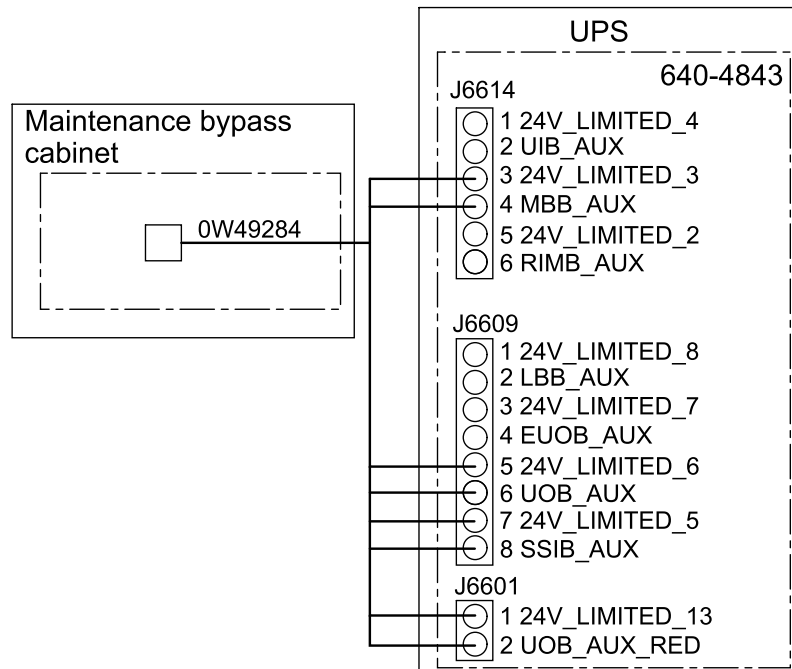

3. Route the signal cables down through the cable channel in the right side of the UPS and into the maintenance bypass cabinet through the cable entry opening.

4. Connect the signal cables at the cable connection point in the maintenance bypass cabinet.

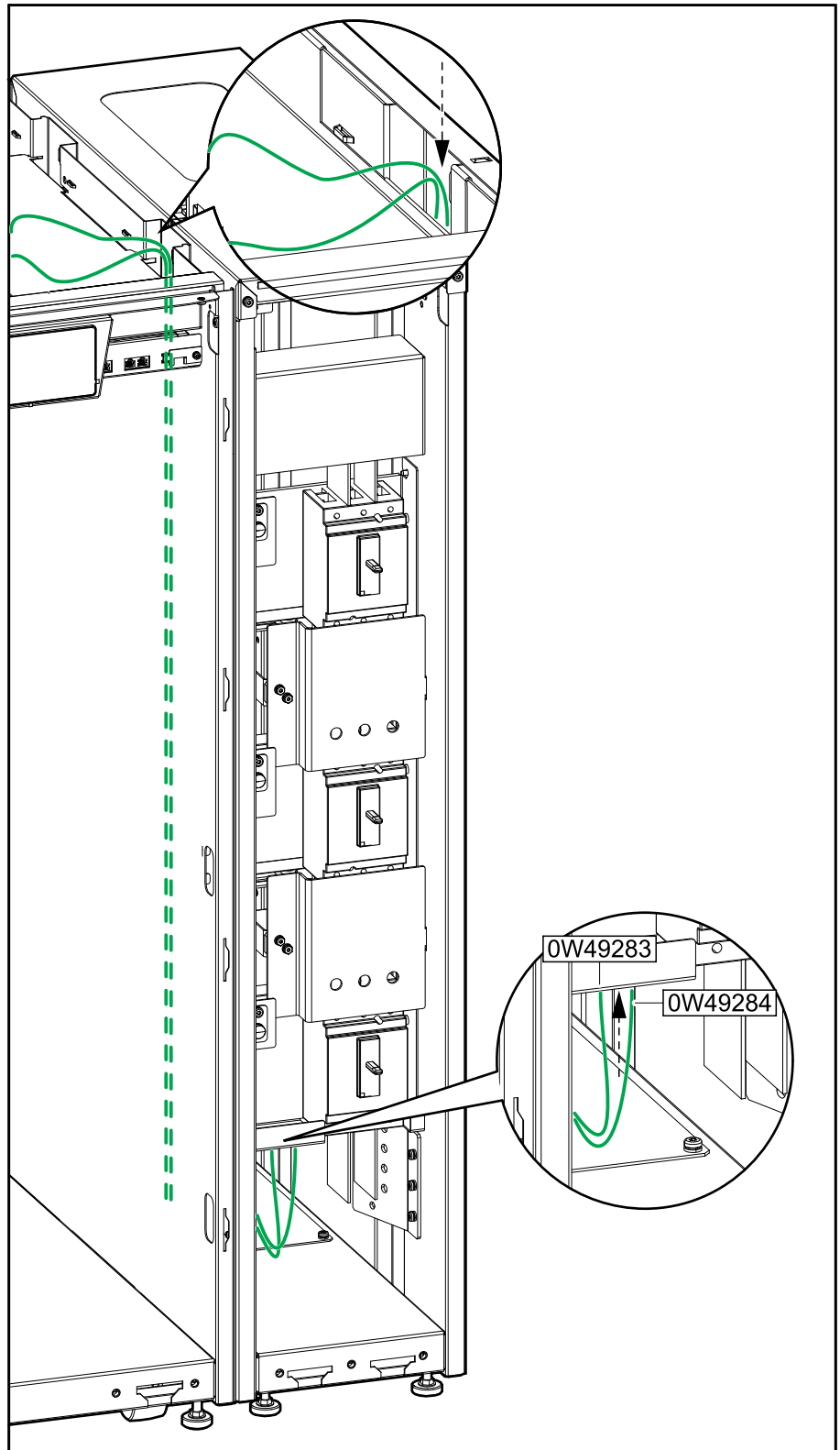

Final Installation

1. Reinstall the upper and lower front plate.

Front View of the Maintenance Bypass Cabinet

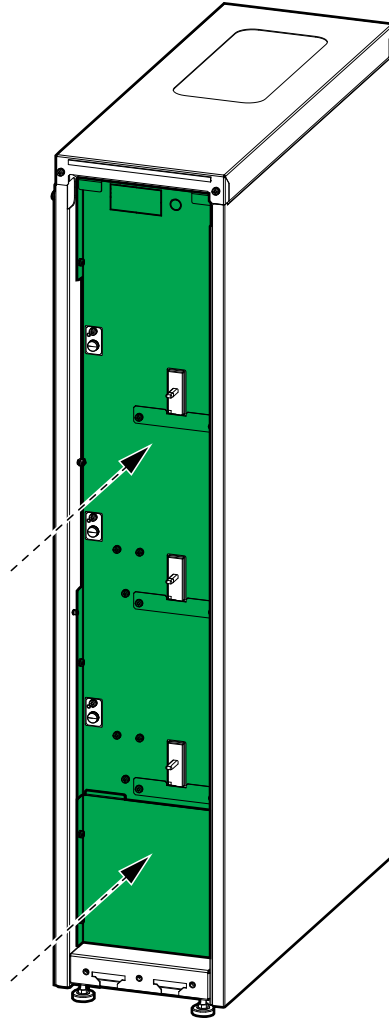

2. **Only for dual mains:** Add the labels SSIB, HSSIB, and the diagram label on the upper front plate. The labels are provided with this manual.

Front View of the Maintenance Bypass Cabinet – Single Mains

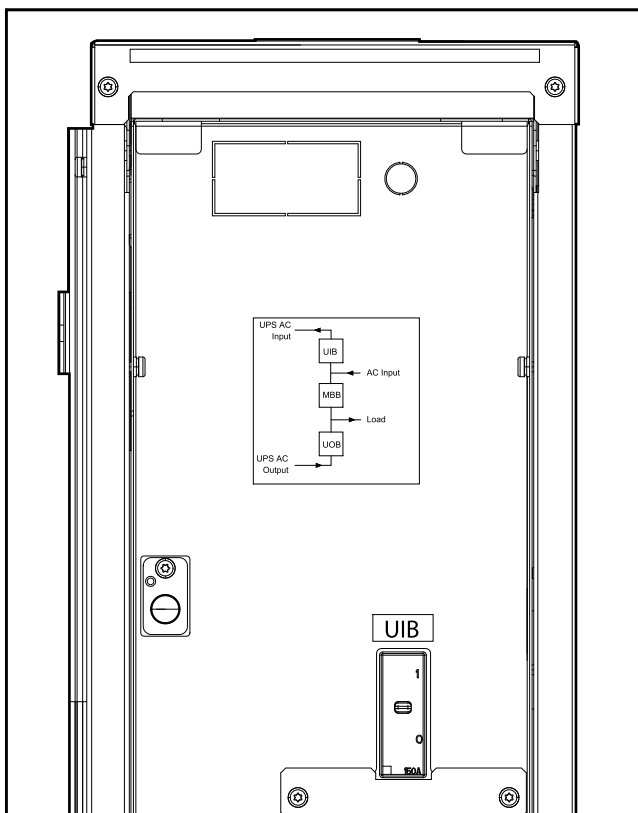

Front View of the Maintenance Bypass Cabinet – Dual Mains

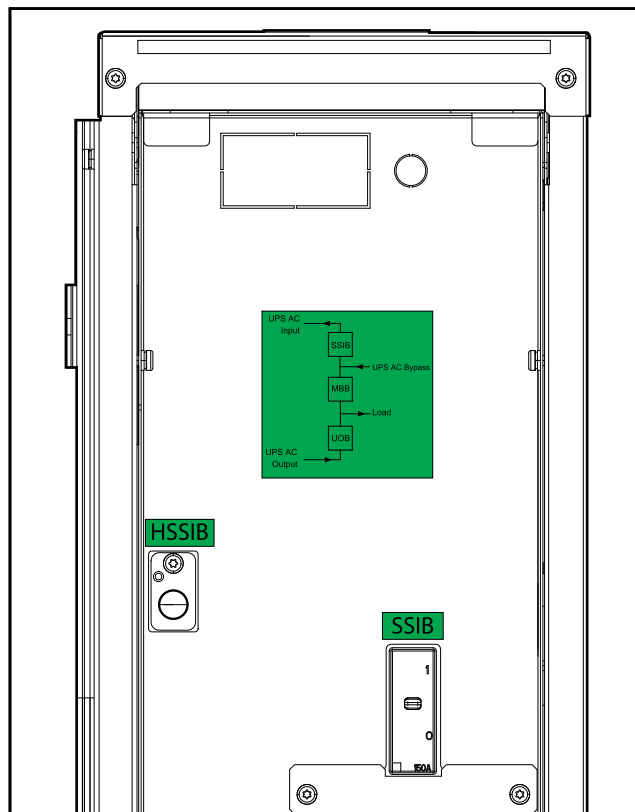

3. **Only for seismic anchoring:**

- a. Install the seismic front anchoring bracket on the maintenance bypass cabinet with the provided M8 bolts.
- b. Mount the seismic front anchoring bracket on the maintenance bypass cabinet to the floor. Use appropriate hardware for the floor type – the hole diameter in the front anchoring bracket is $\varnothing 18$ mm.

Front View of the Maintenance Bypass Cabinet

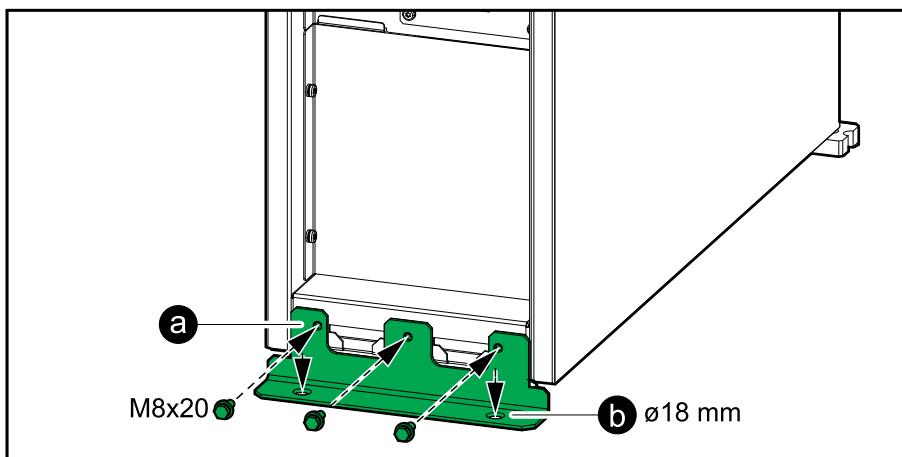

4. Reinstall the front panel on the maintenance bypass cabinet:
 - a. Insert the two tabs in the bottom of the front panel in the maintenance bypass cabinet at a tilted angle.
 - b. Reconnect the front panel strap to the maintenance bypass cabinet.
 - c. Close the front panel and lock with the two locking knobs.

Front Right View of the Maintenance Bypass Cabinet

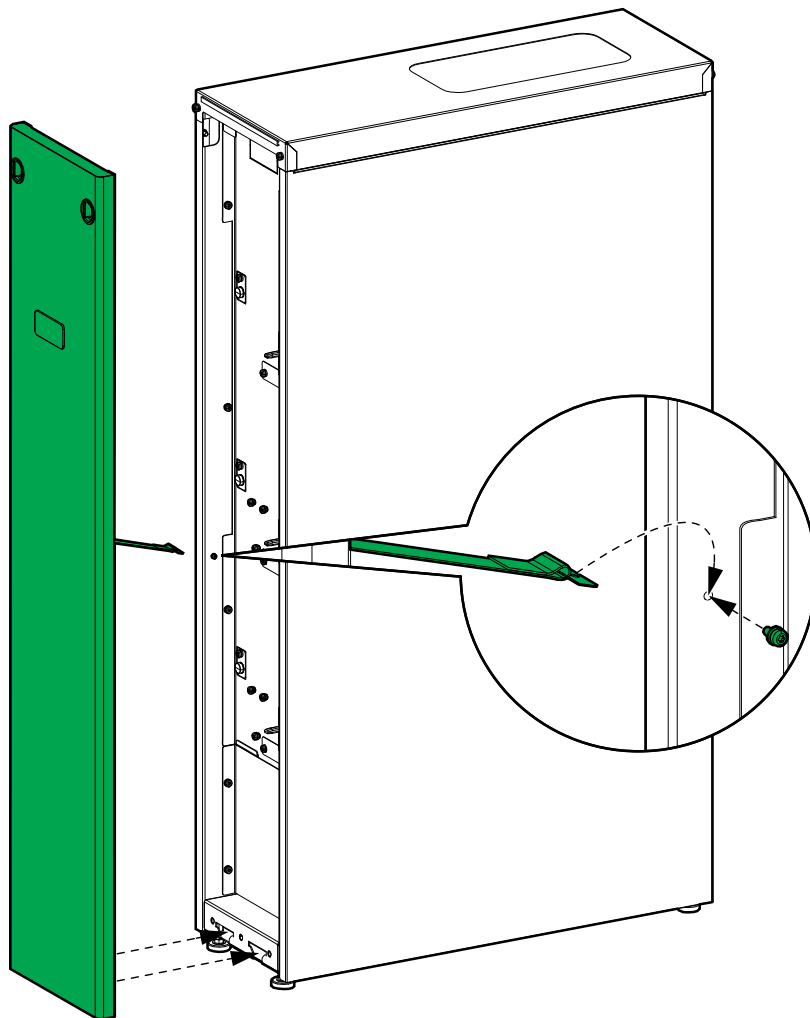

5. Follow the UPS installation manual to connect the internal power cables in the UPS.

Decommission or Move the Maintenance Bypass Cabinet to a New Location

NOTE: Follow the instructions in the UPS installation manual to prepare the UPS for being moved/decommissioned.

1. Shut down the UPS system completely.
2. Lockout/Tagout all breakers in the maintenance bypass cabinet and the upstream switchgear in the OFF (open) position.
3. Lockout/Tagout all battery breakers in the switchgear/battery solution in the OFF (open) position.
4. Remove the front panels from the maintenance bypass cabinet and the UPS.
5. If present, Lockout/Tagout the backfeed breaker BF2 in the OFF (open) position on the UPS.
6. Remove the lower and upper front plate from the maintenance bypass cabinet.

Front View of the Maintenance Bypass Cabinet

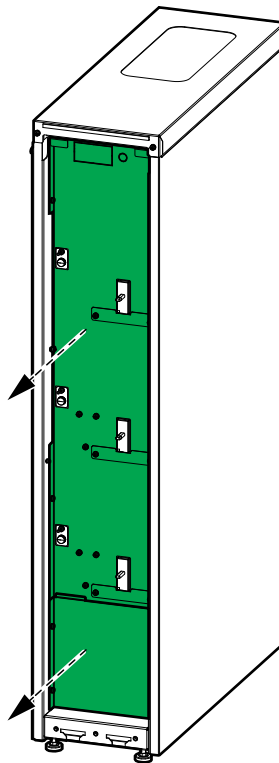

⚡ ⚠ DANGER

HAZARD OF ELECTRIC SHOCK, EXPLOSION, OR ARC FLASH

- Do not remove any other plates or panels while there is power on the system.
- Before any work activity is started it must be confirmed with measurements directly on the terminals that no power is present.

Failure to follow these instructions will result in death or serious injury.

7. On the maintenance bypass cabinet, measure for and verify ABSENCE of voltage with a multimeter probe through the holes in the transparent plate for input/bypass and load.

⚡⚠ DANGER

HAZARD OF ELECTRIC SHOCK, EXPLOSION, OR ARC FLASH

Measure for and verify ABSENCE of voltage with a multimeter probe through the holes in the transparent plate for input/bypass and load.

Failure to follow these instructions will result in death or serious injury.

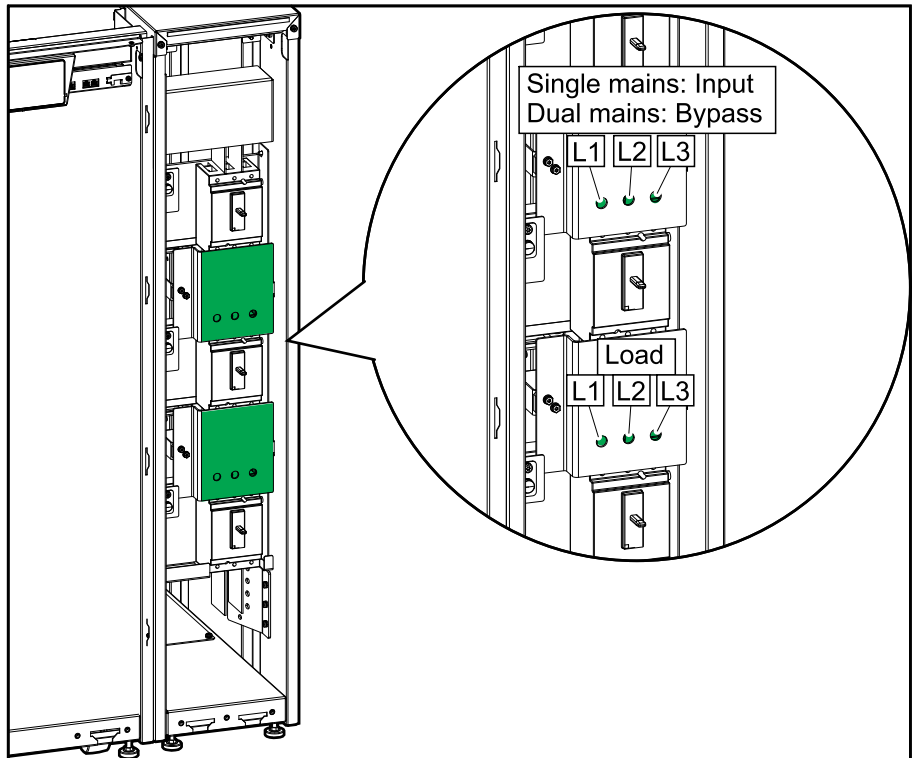

8. On the UPS, measure for and verify ABSENCE of voltage with a multimeter probe on each busbar or terminal for input, bypass, output, neutral, and DC. See UPS installation manual for details.

⚡⚠ DANGER

HAZARD OF ELECTRIC SHOCK, EXPLOSION, OR ARC FLASH

Measure for and verify ABSENCE of voltage on each busbar or terminal for input/bypass/output/neutral/DC busbar before continuing.

Failure to follow these instructions will result in death or serious injury.

9. On the UPS, disconnect and remove the internal power cables coming from the maintenance bypass cabinet. See the UPS installation manual and *Connect the Internal Power Cables*, page 35 for details. Save all parts for reinstallation.
10. Remove the screws in the front that interconnect the UPS and the maintenance bypass cabinet externally. See *Interconnect the UPS and the Maintenance Bypass Cabinet*, page 46 for details. Save all parts for reinstallation.
11. On the UPS, disconnect and remove any signal cables from the UPS. See the UPS installation manual for details.

12. If present, remove the seismic front anchoring bracket from the UPS and the maintenance bypass cabinet. Save for reinstallation.
13. Reinstall the front panel on the UPS.
14. Raise the feet of the UPS until the casters have full contact with the floor.
15. Move the UPS out of the way of the maintenance bypass cabinet by rolling it on the casters.

▲ WARNING
TIPPING HAZARD
<ul style="list-style-type: none">• The casters of the UPS are exclusively for transport on flat, even, hard, and horizontal surfaces.• The casters of the UPS are intended for transport over short distances (i.e. inside the same building).• Move at a slow pace and pay close attention on the floor conditions and the balance of the UPS.
Failure to follow these instructions can result in death, serious injury, or equipment damage.

16. The maintenance bypass cabinet can tip over easily when not interconnected with the UPS or mounted to the floor. Take appropriate precautions to avoid the maintenance bypass cabinet tipping over. If the original front transportation bracket is available and in undamaged condition, install the front transportation bracket on the maintenance bypass cabinet to increase stability.

▲ WARNING
TIPPING HAZARD
The maintenance bypass cabinet can tip over easily when not interconnected with the UPS or mounted to the floor. Take appropriate precautions to avoid the maintenance bypass cabinet tipping over.
Failure to follow these instructions can result in death, serious injury, or equipment damage.

Front View of the Maintenance Bypass Cabinet

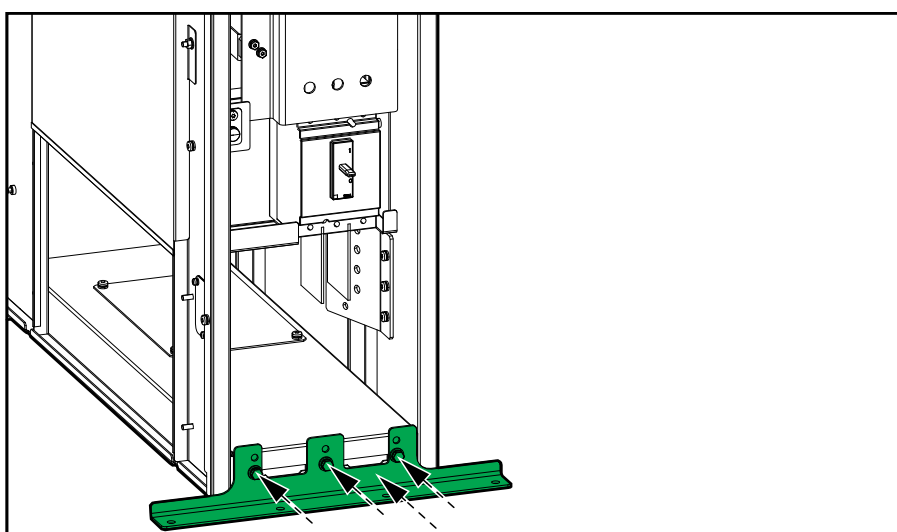

17. Remove the right side panel from the maintenance bypass cabinet and reinstall the right side panel on the UPS. See Prepare the Maintenance Bypass Cabinet and the UPS for Cables, page 31 for details.
18. Remove the left side plates from the maintenance bypass cabinet.

19. Measure for and verify ABSENCE of voltage on each input/bypass/load/neutral/DC busbar in the maintenance bypass cabinet before continuing.

⚡ ⚠ DANGER

HAZARD OF ELECTRIC SHOCK, EXPLOSION, OR ARC FLASH

Measure for and verify ABSENCE of voltage on each input/bypass/load/neutral/DC busbar before continuing.

Failure to follow these instructions will result in death or serious injury.

Left Side View of the 10-80 kW Maintenance Bypass Cabinet – Single Mains

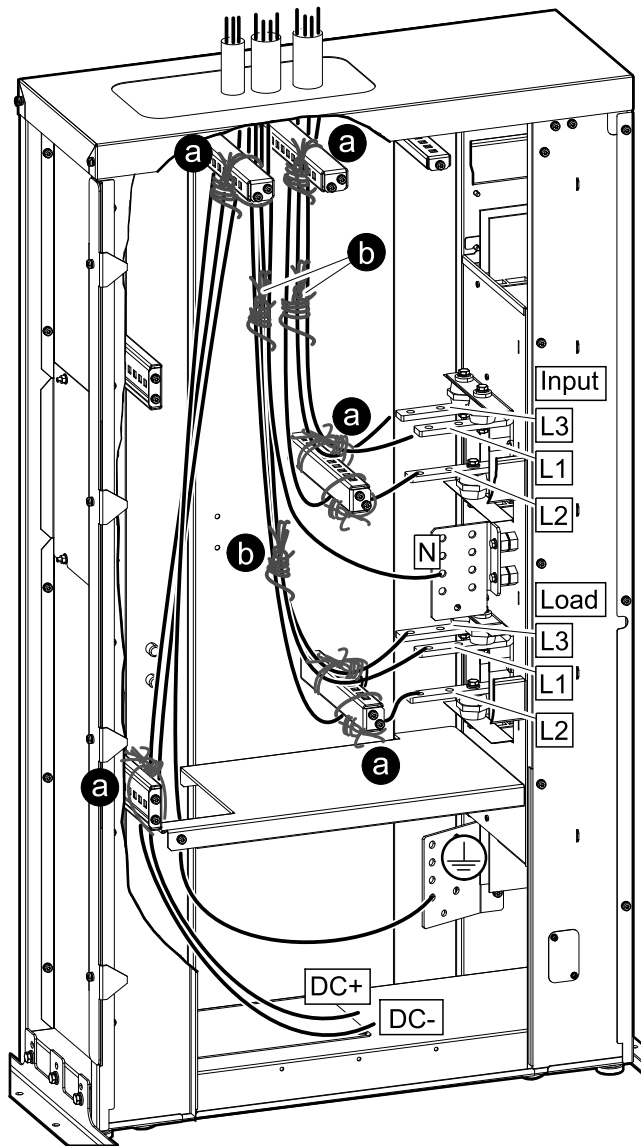

Left Side View of the 10-80 kW Maintenance Bypass Cabinet – Dual Mains

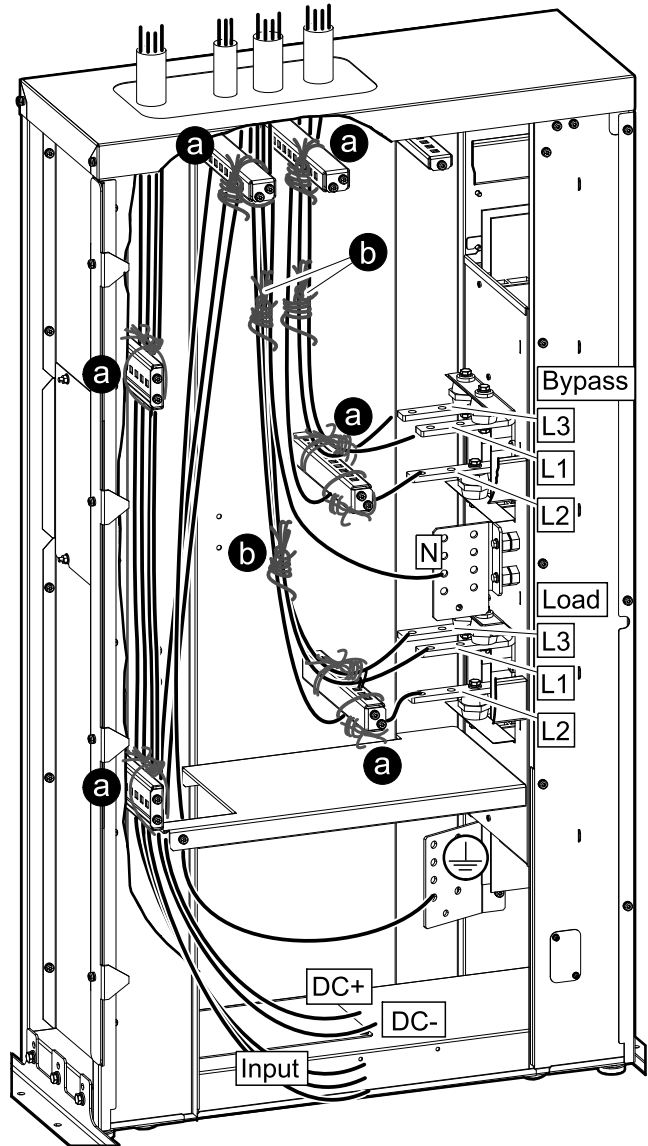

Left Side View of the 100-150 kW Maintenance Bypass Cabinet – Single Mains

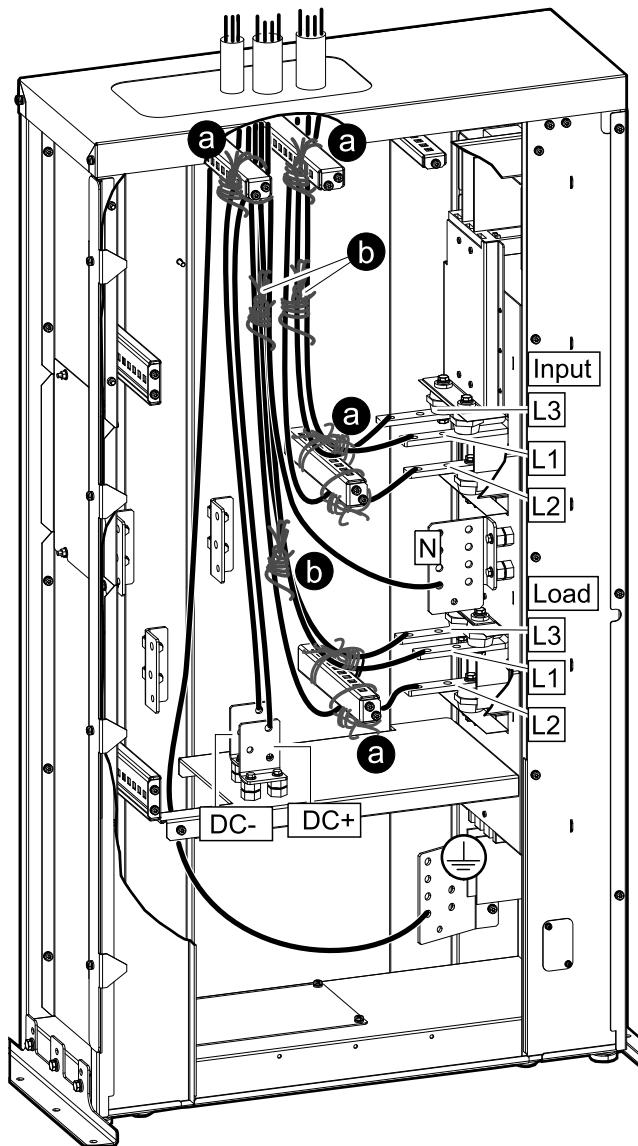

Left Side View of the 100-150 kW Maintenance Bypass Cabinet – Dual Mains

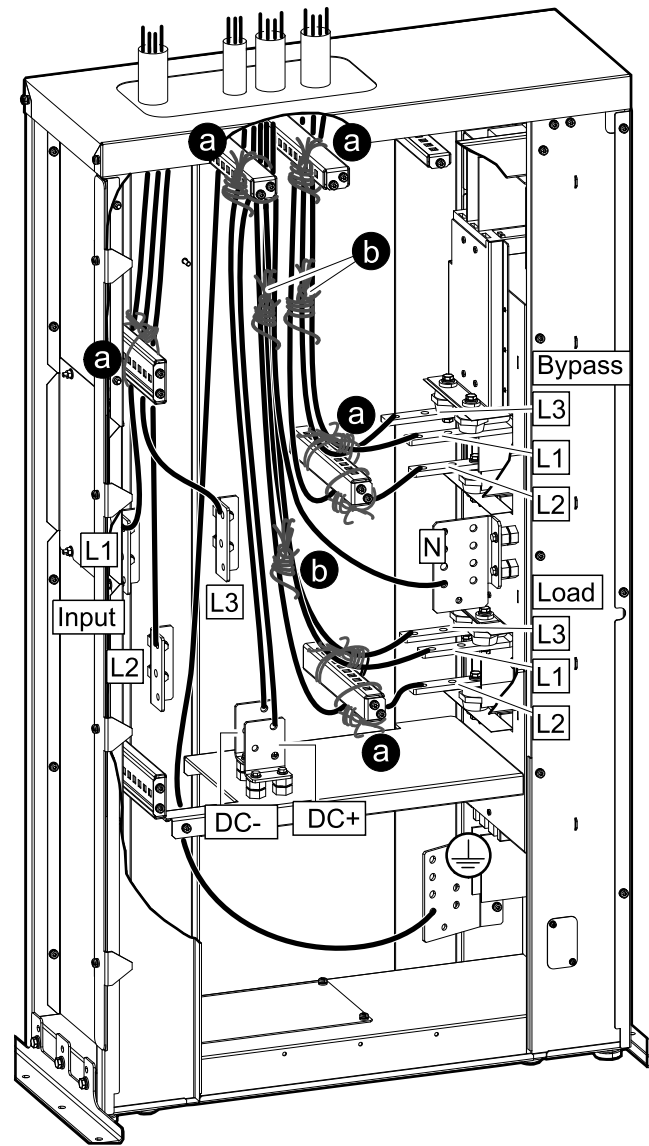

20. Disconnect and remove the power cables from the maintenance bypass cabinet. See *Connect the Power Cables in a 10-80 kW Top Cable Entry System*, page 39, *Connect the Power Cables in a 100-150 kW Top Cable Entry System*, page 41, or *Connect the Power Cables in a Bottom Cable Entry System*, page 45 for details.
21. Disconnect and remove the signal cables from the maintenance bypass cabinet. See *Connect the Signal Cables*, page 51 for details.
22. Reinstall the left side plates on the maintenance bypass cabinet.
23. Reinstall the front panel on the maintenance bypass cabinet.
24. Raise the feet of the maintenance bypass cabinet until the casters have full contact with the floor.

25. You can now move the maintenance bypass cabinet by rolling it over the floor on the casters.

⚠ WARNING

TIPPING HAZARD

- The casters of the maintenance bypass cabinet are exclusively for transport on flat, even, hard, and horizontal surfaces.
- The casters of the maintenance bypass cabinet are intended for transport over short distances (i.e. inside the same building).
- Move at a slow pace and pay close attention on the floor conditions and the balance of the maintenance bypass cabinet.

Failure to follow these instructions can result in death, serious injury, or equipment damage.

26. If present, remove the rear seismic anchoring bracket from the maintenance bypass cabinet and remove the seismic anchors from the floor. Save for reinstallation.
27. The maintenance bypass cabinet can tip over easily when not interconnected with the UPS or mounted to the floor. Take appropriate precautions to avoid the maintenance bypass cabinet tipping over. If the original rear transportation bracket is available and in undamaged condition, install the rear transportation bracket on the maintenance bypass cabinet to increase stability.

⚠ WARNING

TIPPING HAZARD

The maintenance bypass cabinet can tip over easily when not interconnected with the UPS or mounted to the floor. Take appropriate precautions to avoid the maintenance bypass cabinet tipping over during handling and preparation for transport/shipment.

Failure to follow these instructions can result in death, serious injury, or equipment damage.

Rear View of the Maintenance Bypass Cabinet

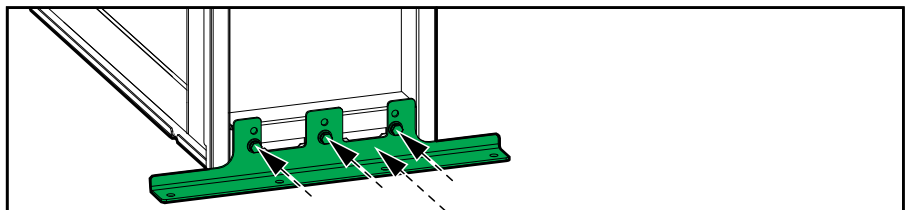

28. **For transport over longer distances or in conditions that are not suitable for the casters of the maintenance bypass cabinet:**

▲ WARNING

TIPPING HAZARD

For transport over longer distances or in conditions that are not suitable for the casters of the maintenance bypass cabinet, ensure:

- that personnel performing the transport have necessary skill and have received adequate training;
- to use appropriate tools to safely lift and transport the maintenance bypass cabinet;
- to protect the product against damage by using appropriate protection (like wrapping or packaging).

Failure to follow these instructions can result in death, serious injury, or equipment damage.

Transportation requirements:

- Mount the maintenance bypass cabinet in a vertical position in the center of a suitable pallet with minimum pallet dimensions: ? mm x ? mm. The pallet must be suitable for the weight of the maintenance bypass cabinet: 110-120 kg (243-265 lbs).
- Use appropriate means of fixation to mount the maintenance bypass cabinet to the pallet.
- The original shipping pallet in combination with the original transportation brackets can be reused, if in undamaged condition.

▲ DANGER

TIPPING HAZARD

- The maintenance bypass cabinet must be appropriately fixed to the pallet immediately after being placed on the pallet.
- The fixation hardware must be strong enough to withstand vibrations and shocks during loading, transport, and unloading.

Failure to follow these instructions will result in death or serious injury.

▲ WARNING

UNEXPECTED EQUIPMENT BEHAVIOR

Do not lift the maintenance bypass cabinet with a forklift/pallet truck directly on the frame as it may bend or damage the frame.

Failure to follow these instructions can result in death, serious injury, or equipment damage.

29. Perform one of the following:

- Decommission the maintenance bypass cabinet, OR
- Move the maintenance bypass cabinet to a new location to install it.

30. **Only for installing the maintenance bypass cabinet in a new location:** Follow the installation manual to install the maintenance bypass cabinet in the new location. See Installation Procedure for Top Cable Entry, page 28 or Installation Procedure for Bottom Cable Entry, page 30 for installation overview. Startup must only be performed by Schneider Electric.

⚡ ⚠ DANGER**HAZARD OF ELECTRIC SHOCK, EXPLOSION, OR ARC FLASH**

Startup must only be performed by Schneider Electric.

Failure to follow these instructions will result in death or serious injury.

Schneider Electric
35 rue Joseph Monier
92500 Rueil Malmaison
France

+ 33 (0) 1 41 29 70 00



As standards, specifications, and design change from time to time,
please ask for confirmation of the information given in this publication.

© 2018 – 2024 Schneider Electric. All rights reserved.

990-5909C-001