

Easy UPS 3S Parallel Maintenance Bypass Panel

10-40 kVA

Installation

03/2020



Legal Information

The Schneider Electric brand and any trademarks of Schneider Electric SE and its subsidiaries referred to in this guide are the property of Schneider Electric SE or its subsidiaries. All other brands may be trademarks of their respective owners.

This guide and its content are protected under applicable copyright laws and furnished for informational use only. No part of this guide may be reproduced or transmitted in any form or by any means (electronic, mechanical, photocopying, recording, or otherwise), for any purpose, without the prior written permission of Schneider Electric.

Schneider Electric does not grant any right or license for commercial use of the guide or its content, except for a non-exclusive and personal license to consult it on an "as is" basis. Schneider Electric products and equipment should be installed, operated, serviced, and maintained only by qualified personnel.

As standards, specifications, and designs change from time to time, information contained in this guide may be subject to change without notice.

To the extent permitted by applicable law, no responsibility or liability is assumed by Schneider Electric and its subsidiaries for any errors or omissions in the informational content of this material or consequences arising out of or resulting from the use of the information contained herein.



Go to <http://www.productinfo.schneider-electric.com/portals/ui/easyups3s/> for translations.

Rendez-vous sur <http://www.productinfo.schneider-electric.com/portals/ui/easyups3s/> pour accéder aux traductions.

Vaya a <http://www.productinfo.schneider-electric.com/portals/ui/easyups3s/> para obtener las traducciones.

Gehe zu <http://www.productinfo.schneider-electric.com/portals/ui/easyups3s/> für Übersetzungen.

Vai a <http://www.productinfo.schneider-electric.com/portals/ui/easyups3s/> per le traduzioni.

Vá para <http://www.productinfo.schneider-electric.com/portals/ui/easyups3s/> para obter as traduções.

Перейдите по ссылке <http://www.productinfo.schneider-electric.com/portals/ui/easyups3s/> для просмотра переводов.

前往 <http://www.productinfo.schneider-electric.com/portals/ui/easyups3s/> 查看译文。

前往 <http://www.productinfo.schneider-electric.com/portals/ui/easyups3s/> 查看譯文。

Table of Contents

Important Safety Instructions — SAVE THESE	
INSTRUCTIONS	5
Electromagnetic Compatibility	6
Safety Precautions	6
Electrical Safety.....	8
Overview of UPS System with Parallel Maintenance Bypass	
Panel.....	9
Specifications for 400 V Systems	11
Specifications for 208 V Systems	12
Specifications	13
Recommended Bolts and Cable Lugs	13
Torque Specifications.....	13
Parallel Maintenance Bypass Panel Weights and Dimensions.....	13
Clearance	13
Environment.....	14
Installation Procedure	15
Mount the Maintenance Bypass Panel to the Wall	16
Prepare the Maintenance Bypass Panel for Cables.....	18
Connect the Power Cables.....	19
Connect the Signal Cables.....	20

Important Safety Instructions — SAVE THESE INSTRUCTIONS

Read these instructions carefully and look at the equipment to become familiar with it before trying to install, operate, service or maintain it. The following safety messages may appear throughout this manual or on the equipment to warn of potential hazards or to call attention to information that clarifies or simplifies a procedure.



The addition of this symbol to a “Danger” or “Warning” safety message indicates that an electrical hazard exists which will result in personal injury if the instructions are not followed.



This is the safety alert symbol. It is used to alert you to potential personal injury hazards. Obey all safety messages with this symbol to avoid possible injury or death.

DANGER

DANGER indicates a hazardous situation which, if not avoided, **will result in death or serious injury.**

Failure to follow these instructions will result in death or serious injury.

WARNING

WARNING indicates a hazardous situation which, if not avoided, **could result in death or serious injury.**

Failure to follow these instructions can result in death, serious injury, or equipment damage.

CAUTION

CAUTION indicates a hazardous situation which, if not avoided, **could result in minor or moderate injury.**

Failure to follow these instructions can result in injury or equipment damage.

NOTICE

NOTICE is used to address practices not related to physical injury. The safety alert symbol shall not be used with this type of safety message.

Failure to follow these instructions can result in equipment damage.

Please Note

Electrical equipment should only be installed, operated, serviced, and maintained by qualified personnel. No responsibility is assumed by Schneider Electric for any consequences arising out of the use of this material.

A qualified person is one who has skills and knowledge related to the construction, installation, and operation of electrical equipment and has received safety training to recognize and avoid the hazards involved.

Electromagnetic Compatibility

NOTICE

RISK OF ELECTROMAGNETIC DISTURBANCE

This is a product Category C3 according to IEC 62040-2. This is a product for commercial and industrial applications in the second environment - installation restrictions or additional measures may be needed to prevent disturbances. The second environment includes all commercial, light industry, and industrial locations other than residential, commercial, and light industrial premises directly connected without intermediate transformer to a public low-voltage mains supply. The installation and cabling must follow the electromagnetic compatibility rules, e.g.:

- the segregation of cables,
- the use of shielded or special cables when relevant,
- the use of grounded metallic cable tray and supports.

Failure to follow these instructions can result in equipment damage.

Safety Precautions

DANGER

HAZARD OF ELECTRIC SHOCK, EXPLOSION, OR ARC FLASH

Read all instructions in the installation manual before installing or working on this product.

Failure to follow these instructions will result in death or serious injury.

DANGER

HAZARD OF ELECTRIC SHOCK, EXPLOSION, OR ARC FLASH

Do not install the product until all construction work has been completed and the installation room has been cleaned.

Failure to follow these instructions will result in death or serious injury.

DANGER

HAZARD OF ELECTRIC SHOCK, EXPLOSION, OR ARC FLASH

The product must be installed according to the specifications and requirements as defined by Schneider Electric. It concerns in particular the external and internal protections (upstream breakers, battery breakers, cabling, etc.) and environmental requirements. No responsibility is assumed by Schneider Electric if these requirements are not respected.

Failure to follow these instructions will result in death or serious injury.

DANGER

HAZARD OF ELECTRIC SHOCK, EXPLOSION, OR ARC FLASH

The UPS system must be installed according to local and national regulations. Install the UPS according to:

- IEC 60364 (including 60364-4-41 - protection against electric shock, 60364-4-42 - protection against thermal effect, and 60364-4-43 - protection against overcurrent), or
- NEC NFPA 70, or
- Canadian Electrical Code (C22.1, Part 1)

depending on which one of the standards apply in your local area.

Failure to follow these instructions will result in death or serious injury.

DANGER

HAZARD OF ELECTRIC SHOCK, EXPLOSION, OR ARC FLASH

- Install the product in a temperature controlled indoor environment free of conductive contaminants and humidity.
- Install the product on a non-flammable, level and solid surface (e.g. concrete) that can support the weight of the system.

Failure to follow these instructions will result in death or serious injury.

DANGER

HAZARD OF ELECTRIC SHOCK, EXPLOSION, OR ARC FLASH

The product is not designed for and must therefore not be installed in the following unusual operating environments:

- Damaging fumes
- Explosive mixtures of dust or gases, corrosive gases, or conductive or radiant heat from other sources
- Moisture, abrasive dust, steam or in an excessively damp environment
- Fungus, insects, vermin
- Salt-laden air or contaminated cooling refrigerant
- Pollution degree higher than 2 according to IEC 60664-1
- Exposure to abnormal vibrations, shocks, and tilting
- Exposure to direct sunlight, heat sources, or strong electromagnetic fields

Failure to follow these instructions will result in death or serious injury.

DANGER

HAZARD OF ELECTRIC SHOCK, EXPLOSION, OR ARC FLASH

Do not drill or cut holes for cables or conduits with the gland plates installed and do not drill or cut holes in close proximity to the UPS.

Failure to follow these instructions will result in death or serious injury.

WARNING

HAZARD OF ARC FLASH

Do not make mechanical changes to the product (including removal of cabinet parts or drilling/cutting of holes) that are not described in the installation manual.

Failure to follow these instructions can result in death, serious injury, or equipment damage.

NOTICE

RISK OF OVERHEATING

Respect the space requirements around the product and do not cover the ventilation openings when the product is in operation.

Failure to follow these instructions can result in equipment damage.

Electrical Safety

This manual contains important safety instructions that should be followed during the installation and maintenance of the UPS system.

DANGER

HAZARD OF ELECTRIC SHOCK, EXPLOSION, OR ARC FLASH

- Electrical equipment must be installed, operated, serviced, and maintained only by qualified personnel.
- Apply appropriate personal protective equipment (PPE) and follow safe electrical work practices.
- Disconnection devices for AC and DC must be provided by others, be readily accessible, and the function of the disconnect device marked for its function.
- Turn off all power supplying the UPS system before working on or inside the equipment.
- Before working on the UPS system, check for hazardous voltage between all terminals including the protective earth.
- The UPS contains an internal energy source. Hazardous voltage can be present even when disconnected from the mains supply. Before installing or servicing the UPS system, ensure that the units are OFF and that mains and batteries are disconnected. Wait five minutes before opening the UPS to allow the capacitors to discharge.
- The UPS must be properly earthed/grounded and due to a high leakage current, the earthing/grounding conductor must be connected first.

Failure to follow these instructions will result in death or serious injury.

When the UPS input is connected through external isolators that, when opened, isolate the neutral or when the automatic backfeed isolation is provided external to the equipment or is connected to an IT power distribution system, a label must be fitted at the UPS input terminals, and on all primary power isolators installed remotely from the UPS area and on external access points between such isolators and the UPS, by the user, displaying the following text (or equivalent in a language which is acceptable in the country in which the UPS system is installed):

DANGER

HAZARD OF ELECTRIC SHOCK, EXPLOSION, OR ARC FLASH

Risk of voltage backfeed. Before working on this circuit: Isolate the UPS and check for hazardous voltage between all terminals including the protective earth.

Failure to follow these instructions will result in death or serious injury.

Overview of UPS System with Parallel Maintenance Bypass Panel

UIB	Unit input breaker
SSIB	Static switch input breaker
UOB	Unit output breaker
MBB	Maintenance bypass breaker
BB	Battery breaker

Single Mains System

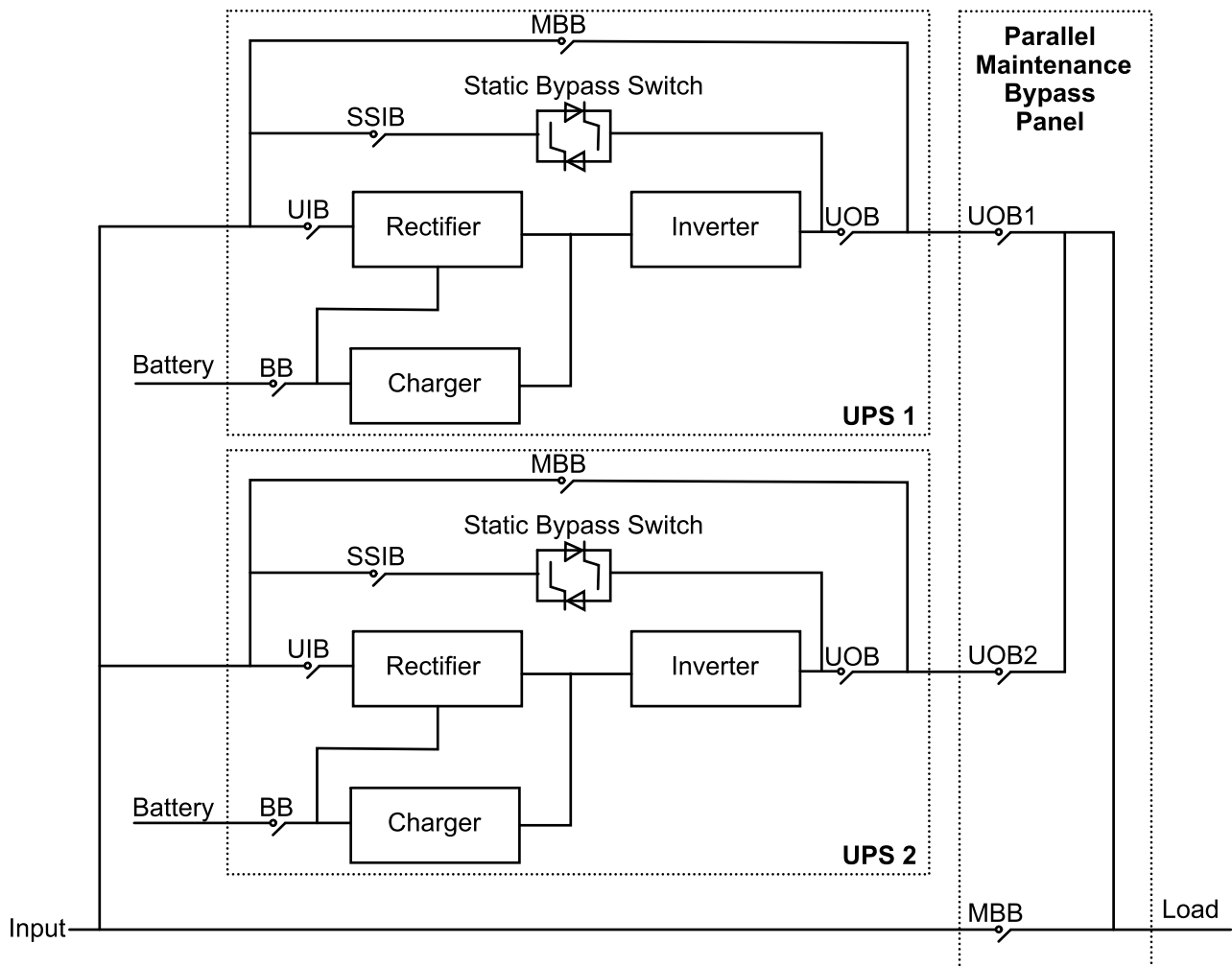

Dual Mains System

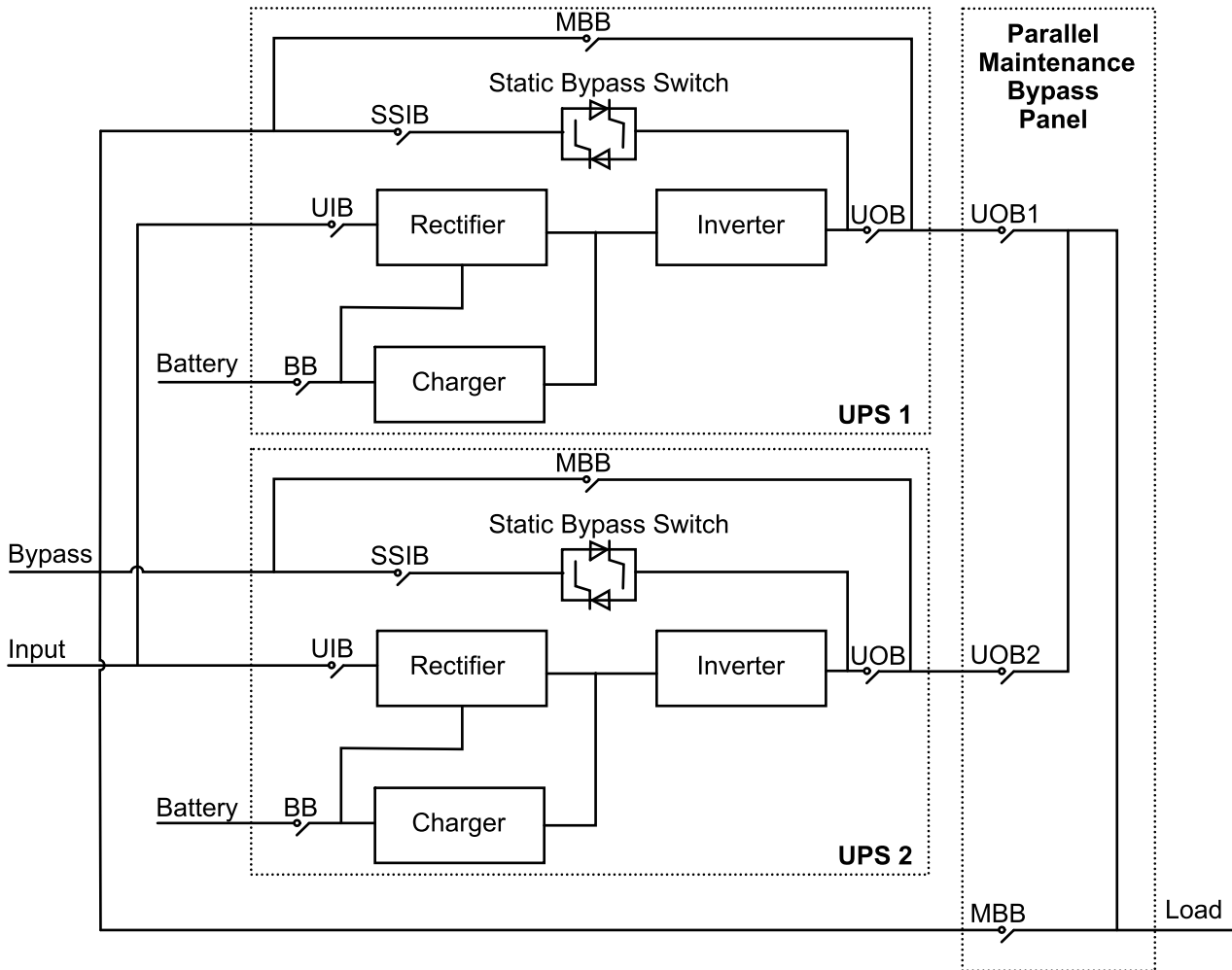

Specifications for 400 V Systems

Maximum Input Short-Circuit Withstand

The maximum input short-circuit withstand for the parallel maintenance bypass panel is ICC=10 kA.

Recommended Cable Sizes

Cable sizes in this manual are based on:

- Single core cables type U1000 R02V
- Specific to AC cables: Maximum length 70 m with a line voltage drop <3% installed on perforated cable trays, XLPE-type insulation, single layer trefoil formation, THDI between 15% and 33% , 35 °C at 400 V grouped in four touching cables

UPS	Cable	Cable Size per Phase (mm ²)
10 kVA	UPS 1 Output/UPS 2 output	6
	System input	16
	System output	16
	PE	10
15 kVA	UPS 1 Output/UPS 2 output	6
	System input	16
	System output	16
	PE	10
20 kVA	UPS 1 Output/UPS 2 output	10
	System input	25
	System output	25
	PE	10
30 kVA	UPS 1 Output/UPS 2 output	16
	System input	35
	System output	35
	PE	16
40 kVA	UPS 1 Output/UPS 2 output	25
	System input	50
	System output	50
	PE	16

Specifications for 208 V Systems

Maximum Input Short-Circuit Withstand

The maximum input short-circuit withstand for the parallel maintenance bypass panel is ICC=10 kA.

Recommended Cable Sizes

Cable sizes in this manual are based on:

- Single core cables type U1000 R02V
- Specific to AC cables: Maximum length 70 m with a line voltage drop <3% installed on perforated cable trays, XLPE-type insulation, single layer trefoil formation, THDI between 15% and 33%, 35 °C at 208 V grouped in four touching cables

UPS	Cable	Cable Size per Phase (mm ²)
10 kVA	UPS 1 Output/UPS 2 output	10
	System input	25
	System output	25
	PE	10
15 kVA	UPS 1 Output/UPS 2 output	16
	System input	35
	System output	35
	PE	16
20 kVA	UPS 1 Output/UPS 2 output	25
	System input	50
	System output	50
	PE	16

Specifications

Recommended Bolts and Cable Lugs

Cable Size (mm ²)	Bolt Size	Cable Lug Type
6	M6	KST TLK6-6
10	M6	KST TLK10-6
16	M6	KST TLK16-6
25	M6	KST DRNB6-25
35	M6	KST TLK35-6
50	M8	KST TLK50-8

Torque Specifications

Bolt size	Torque
M6	5 Nm
M8	12 Nm

Parallel Maintenance Bypass Panel Weights and Dimensions

	Weight kg	Height mm	Width mm	Depth mm
10–40 kVA Parallel Maintenance Bypass Panel	30	600	550	220

Clearance

NOTE: Clearance dimensions are published for airflow and service access only. Consult with the local safety codes and standards for additional requirements in your local area.

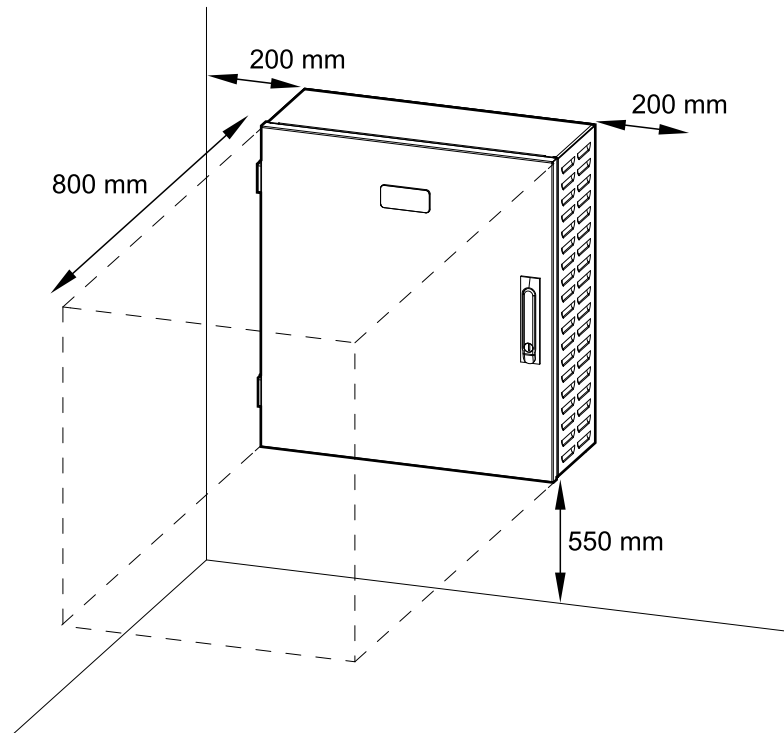

Environment

	Operating	Storage
Temperature	0 °C to 40 °C (32 °F to 104 °F)	-25 °C to 55 °C (-13 °F to 131 °F)
Relative humidity	0-95% non-condensing	0-95% non-condensing
Elevation	0-3000 m (0-10000 feet)	
Protection class	IP20	
Color	RAL 9003, gloss level 85%	

Installation Procedure

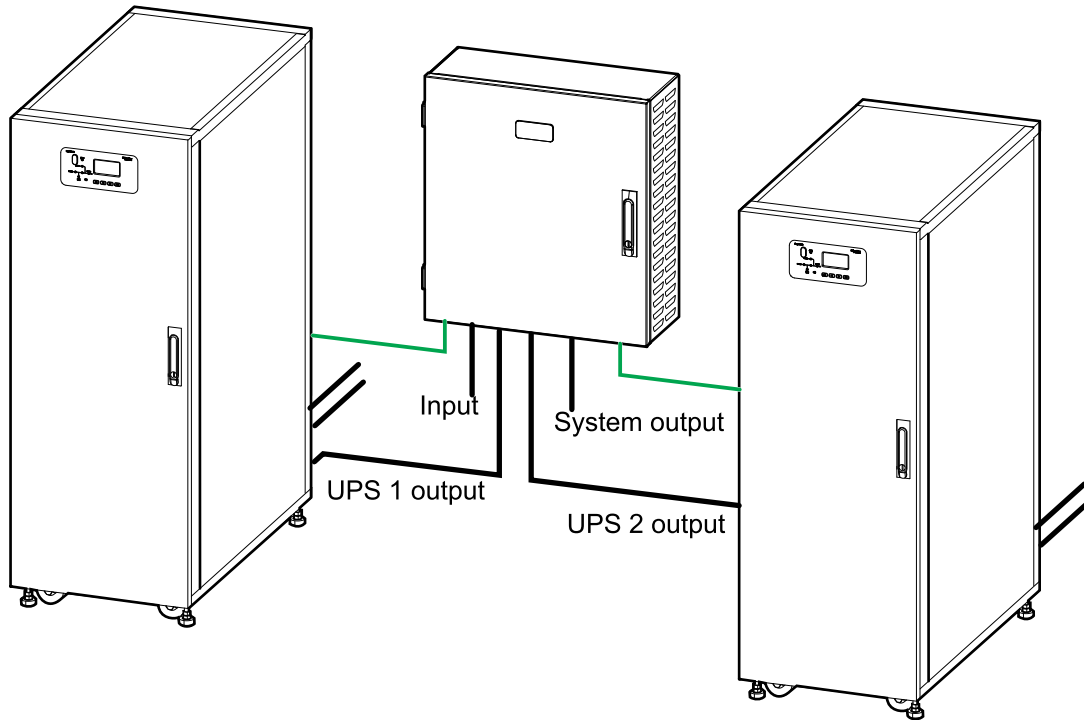

— Signal cable
— Power cable

1. *Mount the Maintenance Bypass Panel to the Wall, page 16.*
2. *Prepare the Maintenance Bypass Panel for Cables, page 18.*
3. *Connect the Power Cables, page 19.*
4. *Connect the Signal Cables, page 20.*

Mount the Maintenance Bypass Panel to the Wall

⚠ CAUTION

RISK OF INJURY OR EQUIPMENT DAMAGE

- Mount the maintenance bypass panel to a wall or a rack that is structurally sound and able to support the weight of the unit.
- Use appropriate hardware for the wall/rack type.

Failure to follow these instructions can result in injury or equipment damage.

1. Measure and mark the four mounting hole locations on the wall.

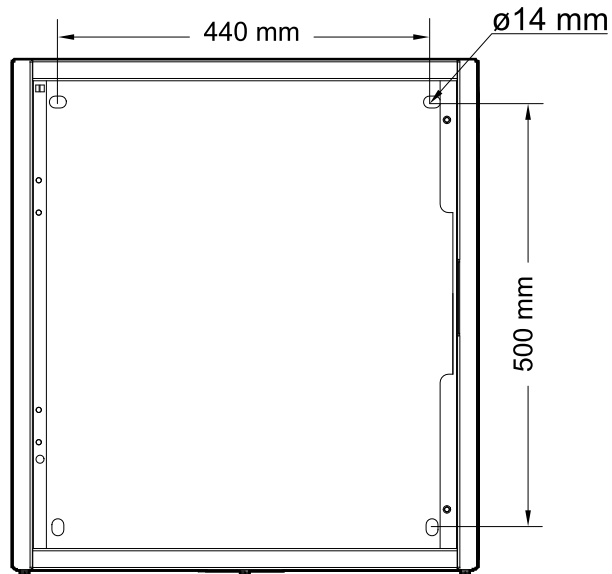

2. Drill holes in each of the four marked locations and mount the anchor bolts.

3. Remove the screws and open the inner door in the maintenance bypass panel.

Front View of the Maintenance Bypass Panel

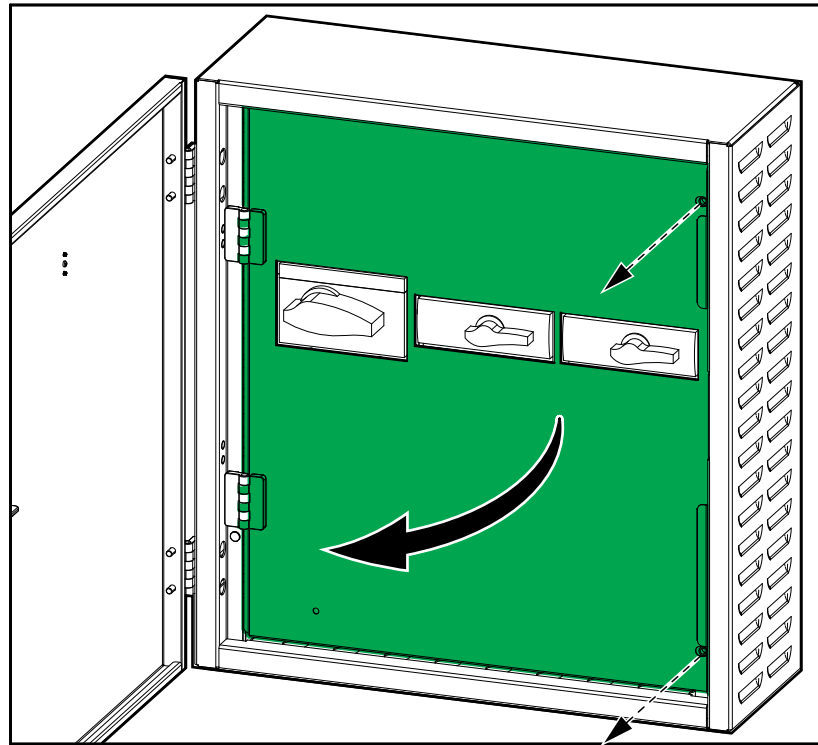

4. Lift the maintenance bypass panel, position it against the wall and line it up with the four anchor bolts. Mount the maintenance bypass panel to the wall.

Prepare the Maintenance Bypass Panel for Cables

⚠ DANGER

HAZARD OF ELECTRIC SHOCK, EXPLOSION, OR ARC FLASH

Do not drill or punch holes with the gland plates installed and do not drill or punch holes in close proximity to the maintenance bypass cabinet.

Failure to follow these instructions will result in death or serious injury.

1. Loosen the six bolts from the bottom gland plate and remove the gland plate.

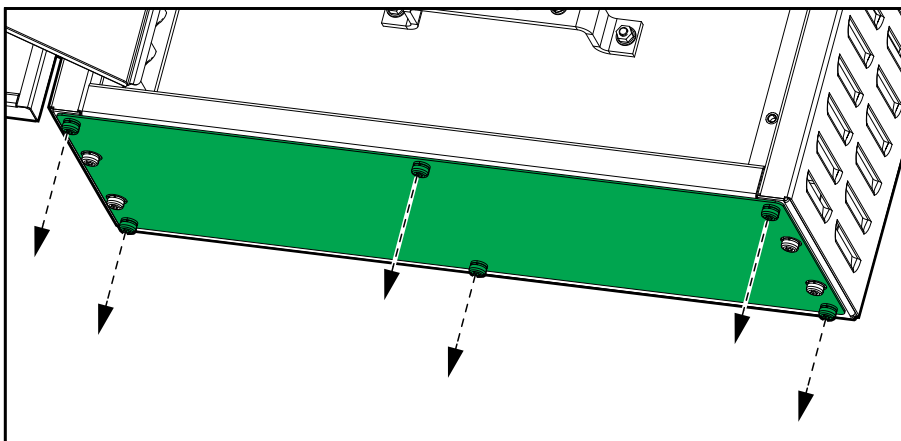

2. Drill or punch holes for cables or grommets.

⚠ DANGER

HAZARD OF ELECTRIC SHOCK, EXPLOSION, OR ARC FLASH

Ensure that there are no sharp edges that can damage the cables.

Failure to follow these instructions will result in death or serious injury.

3. Install grommets (if applicable) and reinstall the gland plate(s).

Connect the Power Cables

1. Connect the PE cables to the PE busbar.

Front View of the Maintenance Bypass Panel

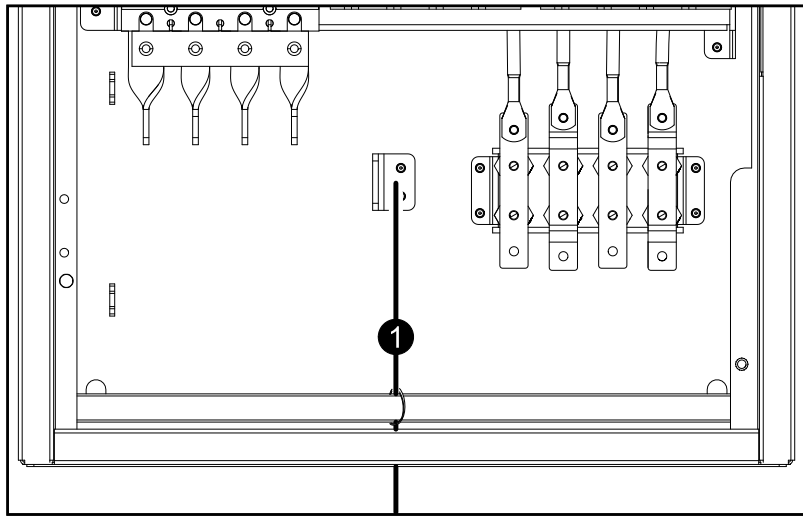

2. Connect the input cables to the maintenance bypass switch MBB.

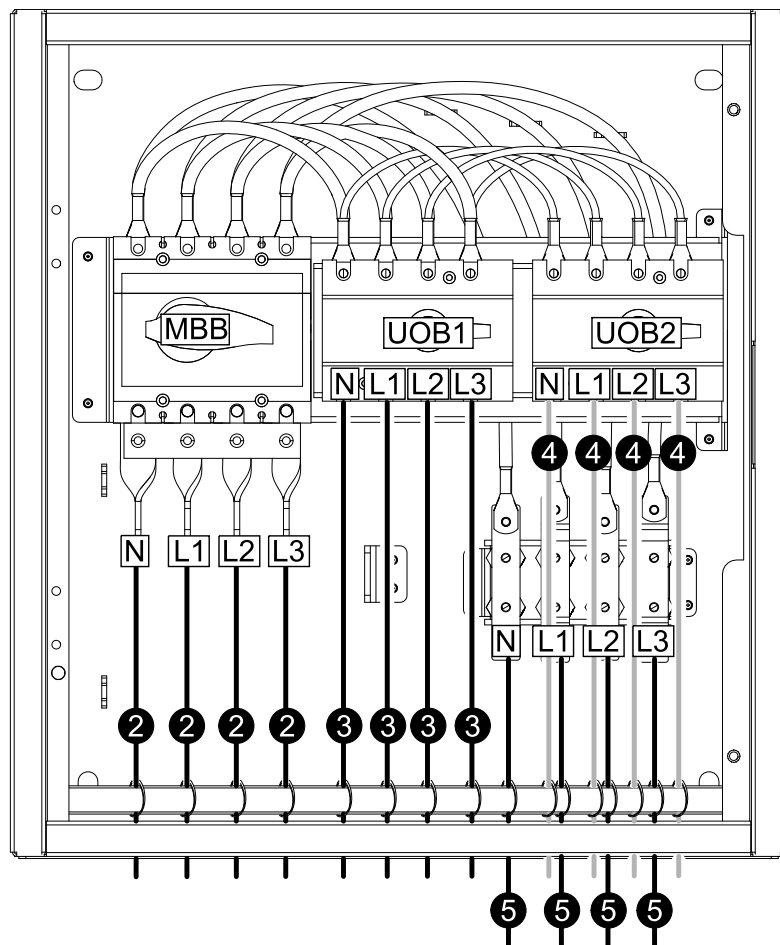

3. Connect the UPS 1 output cables to the unit output switch 1 UOB1.
4. Connect the UPS 2 output cables to the unit output switch 2 UOB2.
5. Connect the system output cables to the system output cables landings.
6. Fasten the cables with cable ties (provided) to the cable reliefs.

Connect the Signal Cables

NOTE: Route the signal cables separately from the power cables.

1. Remove the plastic cover of the maintenance bypass switch MBB to get access to the auxiliary switches.

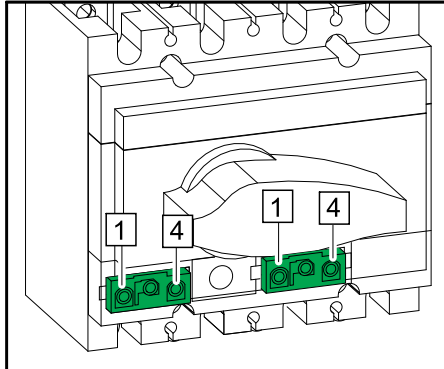

2. Connect signal cables 18 AWG (not supplied) between the maintenance bypass switch MBB and UPS 1 and UPS 2. Use one of the two methods shown below.

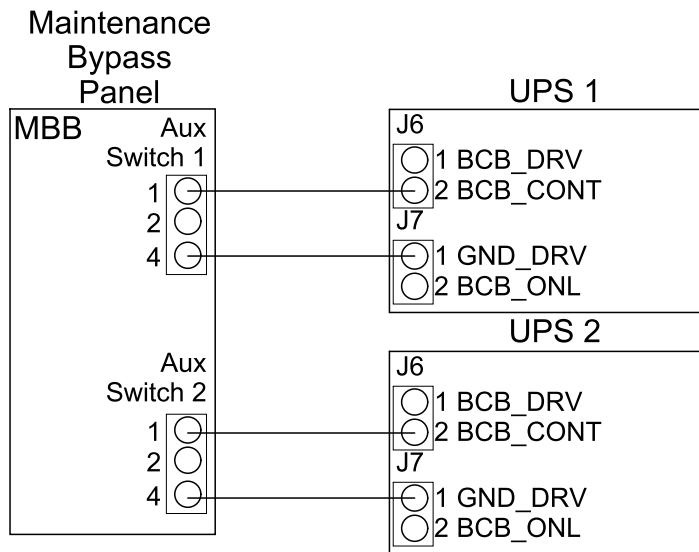
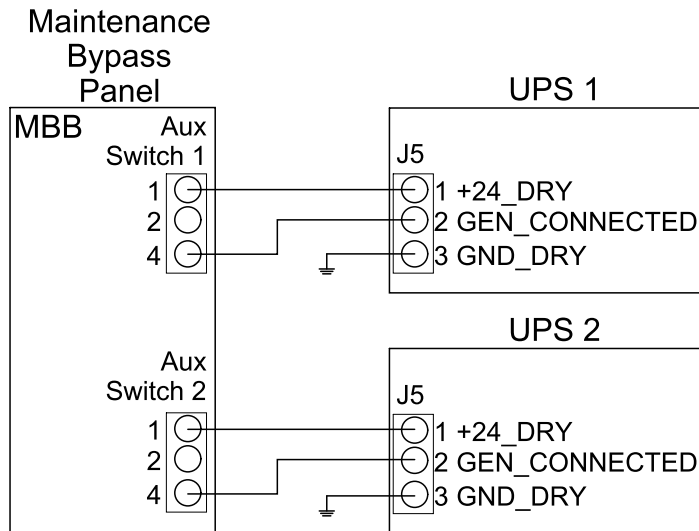

3. Fasten the signal cables to the cable reliefs.

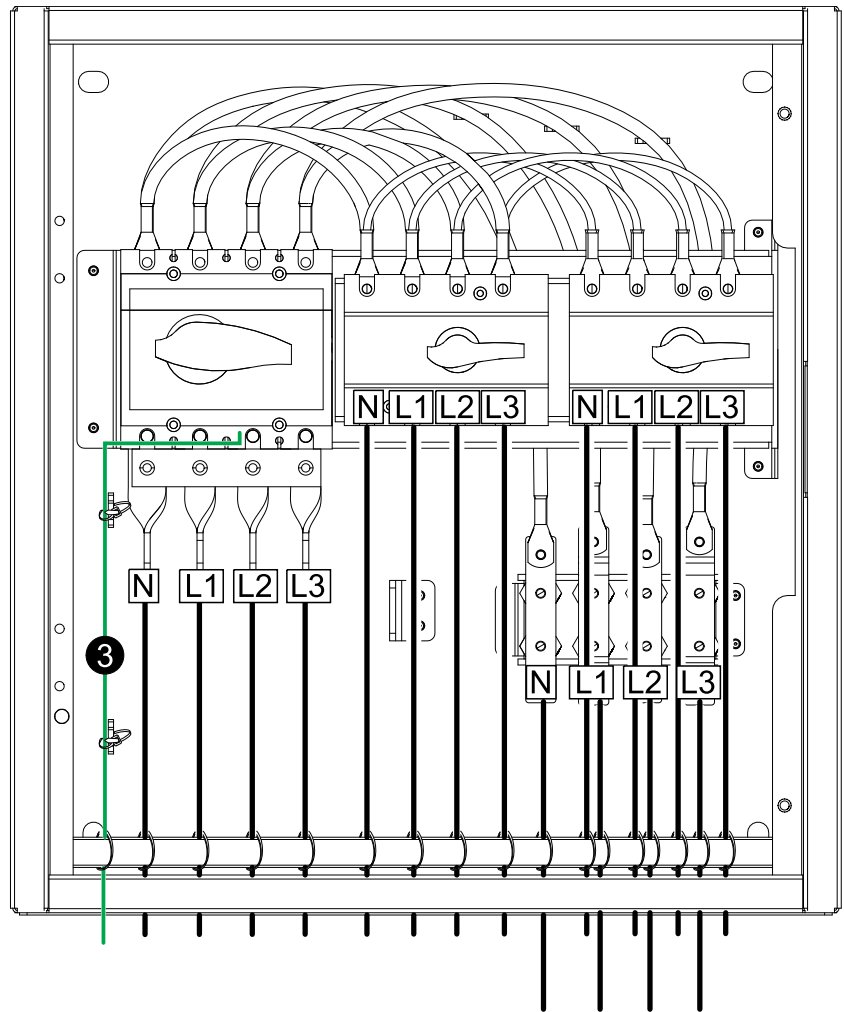

Printed in:
Schneider Electric
35 rue Joseph Monier
92500 Rueil Malmaison – France
+ 33 (0) 1 41 29 70 00

Schneider Electric
35 rue Joseph Monier
92500 Rueil Malmaison
France

+ 33 (0) 1 41 29 70 00



As standards, specifications, and design change from time to time,
please ask for confirmation of the information given in this publication.

© 2018 – 2020 Schneider Electric. All rights reserved.

990-91190A-001