

Easy UPS 3S for External Batteries

10-30 kVA 3:1

Installation

E3SUPS10K3I, E3SUPS15K3I, E3SUPS20K3I, E3SUPS30K3I

Latest updates are available on the Schneider Electric website
6/2023



Legal Information

The Schneider Electric brand and any trademarks of Schneider Electric SE and its subsidiaries referred to in this guide are the property of Schneider Electric SE or its subsidiaries. All other brands may be trademarks of their respective owners.

This guide and its content are protected under applicable copyright laws and furnished for informational use only. No part of this guide may be reproduced or transmitted in any form or by any means (electronic, mechanical, photocopying, recording, or otherwise), for any purpose, without the prior written permission of Schneider Electric.

Schneider Electric does not grant any right or license for commercial use of the guide or its content, except for a non-exclusive and personal license to consult it on an "as is" basis. Schneider Electric products and equipment should be installed, operated, serviced, and maintained only by qualified personnel.

As standards, specifications, and designs change from time to time, information contained in this guide may be subject to change without notice.

To the extent permitted by applicable law, no responsibility or liability is assumed by Schneider Electric and its subsidiaries for any errors or omissions in the informational content of this material or consequences arising out of or resulting from the use of the information contained herein.



Find the manuals here:
Trouvez les manuels ici:
在这里找到手册
Hier finden Sie die Handbücher:
Encuentre los manuales aquí:
Encontre os manuais aqui:



<https://www.productinfo.schneider-electric.com/easyups3s/>

Table of Contents

Important Safety Instructions — SAVE THESE	
INSTRUCTIONS	5
Electromagnetic Compatibility	6
Safety Precautions	6
Electrical Safety	9
Battery Safety	10
Symbols Used in the Product	12
Specifications	13
Input Specifications	13
Bypass Specifications	13
Output Specifications	14
Battery Specifications	14
Required Upstream and Downstream Protection and Cable Sizes	14
Recommended Bolts and Cable Lugs	17
Torque Specifications	17
Weights and Dimensions	18
Shipping Weights and Dimensions	18
Clearance	18
Environmental	19
Compliance	20
Overview	21
Overview of Single UPS	21
Overview of 1+1 Redundant Parallel System with Common Battery Bank	22
Overview of Parallel System	23
Receiving	26
Remove the UPS from the Pallet	26
Connect the Power Cables	29
Connect the Power Cables in the 10-15 kVA UPS	29
Connect the Power Cables in the 20-30 kVA UPS	30
Communication Interfaces	32
Input Contacts and Output Relays	33
Connect the Signal Cables in Parallel Systems	34
Backfeed Protection	35
Appendix: Switch/Breaker Details	38

Important Safety Instructions — SAVE THESE INSTRUCTIONS

Read these instructions carefully and look at the equipment to become familiar with it before trying to install, operate, service or maintain it. The following safety messages may appear throughout this manual or on the equipment to warn of potential hazards or to call attention to information that clarifies or simplifies a procedure.



The addition of this symbol to a “Danger” or “Warning” safety message indicates that an electrical hazard exists which will result in personal injury if the instructions are not followed.



This is the safety alert symbol. It is used to alert you to potential personal injury hazards. Obey all safety messages with this symbol to avoid possible injury or death.

DANGER

DANGER indicates a hazardous situation which, if not avoided, **will result in death or serious injury.**

Failure to follow these instructions will result in death or serious injury.

WARNING

WARNING indicates a hazardous situation which, if not avoided, **could result in death or serious injury.**

Failure to follow these instructions can result in death, serious injury, or equipment damage.

CAUTION

CAUTION indicates a hazardous situation which, if not avoided, **could result in minor or moderate injury.**

Failure to follow these instructions can result in injury or equipment damage.

NOTICE

NOTICE is used to address practices not related to physical injury. The safety alert symbol shall not be used with this type of safety message.

Failure to follow these instructions can result in equipment damage.

Please Note

Electrical equipment should only be installed, operated, serviced, and maintained by qualified personnel. No responsibility is assumed by Schneider Electric for any consequences arising out of the use of this material.

A qualified person is one who has skills and knowledge related to the construction, installation, and operation of electrical equipment and has received safety training to recognize and avoid the hazards involved.

Per IEC 62040-1: "Uninterruptible power systems (UPS) -- Part 1: Safety Requirements," this equipment, including battery access, must be inspected, installed and maintained by a skilled person.

The skilled person is a person with relevant education and experience to enable him or her to perceive risks and to avoid hazards which the equipment can create (reference IEC 62040, section 3.102).

Electromagnetic Compatibility

NOTICE

RISK OF ELECTROMAGNETIC DISTURBANCE

This is a product Category C3 according to IEC 62040-2. This is a product for commercial and industrial applications in the second environment - installation restrictions or additional measures may be needed to prevent disturbances. The second environment includes all commercial, light industry, and industrial locations other than residential, commercial, and light industrial premises directly connected without intermediate transformer to a public low-voltage mains supply. The installation and cabling must follow the electromagnetic compatibility rules, e.g.:

- the segregation of cables,
- the use of shielded or special cables when relevant,
- the use of grounded metallic cable tray and supports.

Failure to follow these instructions can result in equipment damage.

Safety Precautions

⚠ DANGER

HAZARD OF ELECTRIC SHOCK, EXPLOSION, OR ARC FLASH

All safety instructions in this document must be read, understood and followed.

Failure to follow these instructions will result in death or serious injury.

⚠ DANGER

HAZARD OF ELECTRIC SHOCK, EXPLOSION, OR ARC FLASH

Read all instructions in the Installation Manual before installing or working on this UPS system.

Failure to follow these instructions will result in death or serious injury.

⚠ DANGER

HAZARD OF ELECTRIC SHOCK, EXPLOSION, OR ARC FLASH

Do not install the UPS system until all construction work has been completed and the installation room has been cleaned.

Failure to follow these instructions will result in death or serious injury.

⚠ DANGER

HAZARD OF ELECTRIC SHOCK, EXPLOSION, OR ARC FLASH

- The product must be installed according to the specifications and requirements as defined by Schneider Electric. It concerns in particular the external and internal protections (upstream breakers, battery breakers, cabling, etc.) and environmental requirements. No responsibility is assumed by Schneider Electric if these requirements are not respected.
- After the UPS system has been electrically wired, do not start up the system. The start-up requirements depend on the installation country. For countries with bundled start-up service, start-up must be performed by Schneider Electric.

Failure to follow these instructions will result in death or serious injury.

⚠ DANGER

HAZARD OF ELECTRIC SHOCK, EXPLOSION, OR ARC FLASH

The UPS system must be installed according to local and national regulations. Install the UPS according to:

- IEC 60364 (including 60364-4-41 - protection against electric shock, 60364-4-42 - protection against thermal effect, and 60364-4-43 - protection against overcurrent), **or**
- NEC NFPA 70, **or**
- Canadian Electrical Code (C22.1, Part 1)

depending on which one of the standards apply in your local area.

Failure to follow these instructions will result in death or serious injury.

⚠ DANGER

HAZARD OF ELECTRIC SHOCK, EXPLOSION, OR ARC FLASH

- Install the UPS system in a temperature controlled indoor environment free of conductive contaminants and humidity.
- Install the UPS system on a non-flammable, level and solid surface (e.g. concrete) that can support the weight of the system.

Failure to follow these instructions will result in death or serious injury.

⚠ DANGER

HAZARD OF ELECTRIC SHOCK, EXPLOSION, OR ARC FLASH

The UPS is not designed for and must therefore not be installed in the following unusual operating environments:

- Damaging fumes
- Explosive mixtures of dust or gases, corrosive gases, or conductive or radiant heat from other sources
- Moisture, abrasive dust, steam or in an excessively damp environment
- Fungus, insects, vermin
- Salt-laden air or contaminated cooling refrigerant
- Pollution degree higher than 2 according to IEC 60664-1
- Exposure to abnormal vibrations, shocks, and tilting
- Exposure to direct sunlight, heat sources, or strong electromagnetic fields

Failure to follow these instructions will result in death or serious injury.

⚠ DANGER**HAZARD OF ELECTRIC SHOCK, EXPLOSION, OR ARC FLASH**

Do not drill or cut holes for cables or conduits with the gland plates installed and do not drill or cut holes in close proximity to the UPS.

Failure to follow these instructions will result in death or serious injury.

⚠ WARNING**HAZARD OF ARC FLASH**

Do not make mechanical changes to the product (including removal of cabinet parts or drilling/cutting of holes) that are not described in the Installation Manual.

Failure to follow these instructions can result in death, serious injury, or equipment damage.

NOTICE**RISK OF OVERHEATING**

Respect the space requirements around the UPS system and do not cover the product's ventilation openings when the UPS system is in operation.

Failure to follow these instructions can result in equipment damage.

NOTICE**RISK OF EQUIPMENT DAMAGE**

The UPS must use an external regenerative braking kit to dissipate energy when connected to regenerative loads including photovoltaic systems and speed drives.

Failure to follow these instructions can result in equipment damage.

Electrical Safety

⚠ DANGER

HAZARD OF ELECTRIC SHOCK, EXPLOSION, OR ARC FLASH

- Electrical equipment must be installed, operated, serviced, and maintained only by qualified personnel.
- Apply appropriate personal protective equipment (PPE) and follow safe electrical work practices.
- Turn off all power supplying the UPS system before working on or inside the equipment.
- Before working on the UPS system, check for hazardous voltage between all terminals including the protective earth.
- The UPS contains an internal energy source. Hazardous voltage can be present even when disconnected from the mains supply. Before installing or servicing the UPS system, ensure that the units are OFF and that mains and batteries are disconnected. Wait five minutes before opening the UPS to allow the capacitors to discharge.
- A disconnection device (e.g. disconnection circuit breaker or switch) must be installed to enable isolation of the system from upstream power sources in accordance with local regulations. The disconnection device must be easily accessible and visible.
- The UPS must be properly earthed/grounded and due to a high leakage current, the earthing/grounding conductor must be connected first.

Failure to follow these instructions will result in death or serious injury.

⚠ DANGER

HAZARD OF ELECTRIC SHOCK, EXPLOSION, OR ARC FLASH

In systems where backfeed protection is not part of the standard design, an automatic isolation device (backfeed protection option or other device meeting the requirements of IEC/EN 62040-1 or UL1778 5th Edition – depending on which of the two standards apply to your local area) must be installed to prevent hazardous voltage or energy at the input terminals of the isolation device. The device must open within 15 seconds after the upstream power supply fails and must be rated according to the specifications.

Failure to follow these instructions will result in death or serious injury.

When the UPS input is connected through external isolators that, when opened, isolate the neutral or when the automatic backfeed isolation is provided external to the equipment or is connected to an IT power distribution system, a label must be fitted at the UPS input terminals, and on all primary power isolators installed remote from the UPS area and on external access points between such isolators and the UPS, by the user, displaying the following text (or equivalent in a language which is acceptable in the country in which the UPS system is installed):

⚠ DANGER

HAZARD OF ELECTRIC SHOCK, EXPLOSION, OR ARC FLASH

Risk of Voltage Backfeed. Before working on this circuit: Isolate the UPS and check for hazardous voltage between all terminals including the protective earth.

Failure to follow these instructions will result in death or serious injury.

⚠ CAUTION**RISK OF ELECTRICAL DISTURBANCE**

This product can cause a DC current in the PE conductor. Where a residual current-operated protective device (RCD) is used for protection against electrical shock, only an RCD of Type B is allowed on the supply side of this product.

Failure to follow these instructions can result in injury or equipment damage.

Battery Safety**⚠⚠ DANGER****HAZARD OF ELECTRIC SHOCK, EXPLOSION, OR ARC FLASH**

- Battery circuit breakers must be installed according to the specifications and requirements as defined by Schneider Electric.
- Servicing of batteries must only be performed or supervised by qualified personnel knowledgeable of batteries and the required precautions. Keep unqualified personnel away from batteries.
- Disconnect charging source prior to connecting or disconnecting battery terminals.
- Do not dispose of batteries in a fire as they can explode.
- Do not open, alter, or mutilate batteries. Released electrolyte is harmful to the skin and eyes. It may be toxic.

Failure to follow these instructions will result in death or serious injury.

⚠⚠ DANGER**HAZARD OF ELECTRIC SHOCK, EXPLOSION, OR ARC FLASH**

Batteries can present a risk of electric shock and high short-circuit current. The following precautions must be observed when working on batteries

- Remove watches, rings, or other metal objects.
- Use tools with insulated handles.
- Wear protective glasses, gloves and boots.
- Do not lay tools or metal parts on top of batteries.
- Disconnect the charging source prior to connecting or disconnecting battery terminals.
- Determine if the battery is inadvertently grounded. If inadvertently grounded, remove source from ground. Contact with any part of a grounded battery can result in electric shock. The likelihood of such shock can be reduced if such grounds are removed during installation and maintenance (applicable to equipment and remote battery supplies not having a grounded supply circuit).

Failure to follow these instructions will result in death or serious injury.

⚠⚠ DANGER**HAZARD OF ELECTRIC SHOCK, EXPLOSION, OR ARC FLASH**

When replacing batteries, always replace with the same type and number of batteries or battery packs.

Failure to follow these instructions will result in death or serious injury.















▲ CAUTION

RISK OF EQUIPMENT DAMAGE

- Mount the batteries in the UPS system, but do not connect the batteries until the UPS system is ready to be powered up. The time duration from battery connection until the UPS system is powered up must not exceed 72 hours or 3 days.
- Batteries must not be stored more than six months due to the requirement of recharging. If the UPS system remains de-energized for a long period, we recommend that you energize the UPS system for a period of 24 hours at least once every month. This charges the batteries, thus avoiding irreversible damage.

Failure to follow these instructions can result in injury or equipment damage.

Symbols Used in the Product

	This is the earthing/ground symbol.
	This is the protective earth/equipment grounding conductor symbol.
	This is the direct current symbol. It is also referred to as DC.
	This is the alternating current symbol. It is also referred to as AC.
	This is the positive polarity symbol. It is used to identify the positive terminal(s) of equipment which is used with, or generates direct current.
	This is the negative polarity symbol. It is used to identify the negative terminal(s) of equipment which is used with, or generates direct current.
	This is the battery symbol.
	This is the static switch symbol. It is used to indicate switches that are designed to connect or disconnect the load to or from the supply respectively without the existence of moving parts.
	This is the AC/DC converter (rectifier) symbol. It is used to identify an AC/DC converter (rectifier) and, in case of plug-in devices, to identify the relevant receptacles.
	This is the DC/AC converter (inverter) symbol. It is used to identify an DC/AC converter (inverter) and, in case of plug-in devices, to identify the relevant receptacles.
	This is the input symbol. It is used to identify an input terminal when it is necessary to distinguish between inputs and outputs.
	This is the output symbol. It is used to identify an output terminal when it is necessary to distinguish between inputs and outputs.
	This is the switch disconnecter symbol. It is used to identify the disconnecting device in the form of switch.
	This is the circuit breaker symbol. It is used to identify the disconnecting device in the form of circuit breaker that protects the equipment from short circuit or heavy load current. It opens the circuits once the current flow crosses its maximum limit.

Specifications

Input Specifications

	10 kVA			15 kVA			20 kVA			30 kVA		
Voltage (V)	380	400	415	380	400	415	380	400	415	380	400	415
Connections	L1, L2, L3, N, PE											
Input voltage range (V)	304–477											
Frequency range (Hz)	45–65											
Nominal input current (A)	16	15	15	24	23	22	32	31	30	48	46	44
Maximum input current (A)	19	18	18	29	28	26	38	37	36	58	55	53
Input current limitation (A)	22	20	20	33	31	30	44	42	41	65	63	60
Total harmonic distortion (THDI)	<4% for 10 kVA UPS <5% for 15–30 kVA UPS											
Input power factor	> 0.99											
Maximum input shortcircuit withstand	I _{cc} =10 kA											
Protection	Circuit breaker and fuse									Fuse		
Ramp-in	15 seconds											

Bypass Specifications

	10 kVA			15 kVA			20 kVA			30 kVA		
Voltage (V)	220	230	240	220	230	240	220	230	240	220	230	240
Connections	L, N, PE											
Overload capacity	125% continuous 125–130% for 10 minutes 130–150% for 1 minute >150% for 300 milliseconds											
Minimum bypass voltage (V)	176	184	192	176	184	192	176	184	192	176	184	192
Maximum bypass voltage (V)	253	264	276	253	264	276	253	264	276	253	264	276
Frequency (Hz)	50 or 60											
Nominal bypass current (A)	46	43	42	69	66	63	91	87	84	137	131	125
Maximum input short circuit withstand	I _{cc} =10 kA											

Output Specifications

	10 kVA			15 kVA			20 kVA			30 kVA		
Voltage (V)	220	230	240	220	230	240	220	230	240	220	230	240
Connections	L, N, PE											
Overload capacity	110% for 60 minutes 125% for 10 minutes 150% for 1 minute >150% for less than 200 milliseconds											
Output voltage tolerance	± 1%											
Dynamic load response	40 milliseconds											
Output power factor	1.0						1.0 ¹					
Nominal output current (A)	46	43	42	69	66	63	91	87	84	137	131	125
Output short circuit current	154 A/242 ms			168 A/242 ms			236 A/247 ms			339 A/239 ms		
Total harmonic distortion (THDU)	<1% at 100% balanced linear load <5.5% at 100% non-linear load											
Output frequency (Hz)	50 or 60											
Slew rate (Hz/sec)	Programmable: 0.1 to 5.0. Default is 2.0.											
Output performance classification (according to EN62040-3)	VFI-SS-111											

Battery Specifications

	10 kVA	15 kVA	20 kVA	30 kVA
Charging power	Programmable from 1% to 20% of UPS capacity. Default is 10%.			
Maximum charging power (W)	2000	3000	4000	6000
Nominal battery voltage (16–20 blocks) (VDC)	± 192 to ± 240			
Nominal float voltage (16–20 blocks) (VDC)	± 216 to ± 270			
End of discharge voltage (16–20 blocks) (full load) (VDC)	± 158 to ± 198			
End of discharge voltage (16–20 blocks) (no load) (VDC)	± 168 to ± 210			
Battery current at full load and nominal battery voltage (16–20 blocks) (A)	28–22	42–33	55–44	83–66
Battery current at full load and minimum battery voltage (16–20 blocks) (A)	34–27	50–40	67–54	101–81
Temperature compensation (per cell)	Programmable from 0–5 mV. Default is 3 mV.			
Ripple current	< 5% C10			

Required Upstream and Downstream Protection and Cable Sizes

NOTE: Overcurrent protection must be provided by others.

Cable sizes in this manual are based on table B.52.5 of IEC 60364-5-52 with the following assertions:

1. When ambient temperature is below 30 °C. When the ambient temperature is above 30 °C, the power factor is 0.9.

- 90 °C conductors
- An ambient temperature of 30 °C
- Use of copper conductors
- Installation method C
- PE size is based on table 54.2 of IEC 60364-5-54
- Specific to AC cables: Maximum length 70 m with a line voltage drop <3% installed on perforated cable trays, XLPE-type insulation, single layer trefoil formation, THDI between 15% and 33% , 35 °C at 400 V grouped in four touching cables
- Specific to DC cables: Maximum length 15 m with a line voltage drop <1%

NOTE: If neutral conductor is expected to carry a high current, due to line-neutral non-linear load, the circuit breaker must be rated according to expected neutral current.

NOTE: If the ambient temperature is greater than 30 °C, large conductors are to be used in accordance with the correction factors of the IEC.

10 kVA UPS

	Breaker type	Cable size per phase (mm ²)	PE cable size (mm ²)
Input – single mains Input – dual mains	iC65H-C-50A / C60H-C-50A iC65H-C-20A / C60H-C-20A	16 6	16 6
Bypass	iC65H-C-50A / C60H-C-50A	16	16
Output	C65N-B-2P-25A/ C60N-B-2P-25A	16	16
Battery	Compact NSX100F DC TM50D - 3P	8	8

15 kVA UPS

	Breaker type	Cable size per phase (mm ²)	PE cable size (mm ²)
Input – single mains Input – dual mains	C120H-C-80A / NSX100F TM80C 80A iC65H-C-32A / C60H-C-32A	25 6	16 6
Bypass	C120H-C-80A / NSX100F TM80C 80A	25	16
Output	C65N-B-2P-25A/ C60N-B-2P-25A	25	16
Battery	Compact NSX100F DC TM63D - 3P	8	8

20 kVA UPS

	Breaker type	Cable size per phase (mm ²)	PE cable size (mm ²)
Input – single mains Input – dual mains	C120H-C-100A / NSX100F TM100C 100A iC65H-C-40A / C60H-C-40A	35 10	16 10
Bypass	C120H-C-100A / NSX100F TM100C 100A	35	16
Output	C65N-B-2P-32A/ C60N-B-2P-32A	35	16
Battery	Compact NSX100F DC TM80D - 3P	16	16

30 kVA UPS

	Breaker type	Cable size per phase (mm ²)	PE cable size (mm ²)
Input – single mains Input – dual mains	Compact NSX160F TM160C 160A iC65H-C-63A / C60H-C-63A / C120H-C-63A	50 16	25 16
Bypass	Compact NSX160F TM160C 160A	50	25
Output	C65N-B-2P-50A/ C60N-B-2P-50A	50	25
Battery	Compact NSX160F DC TM125D - 3P	25	16

NOTE:

- These protection device ensures discrimination for each of the Easy 3S output circuits.
- If the recommended downstream protection is not installed and a short-circuit occurs, the result may be a break longer than 50 ms on all the other output circuits.
- The recommended output branch breakers are for reference only. Whether to include the output branch breakers in your circuit depends on your use cases.

Recommended Bolts and Cable Lugs

Cable Size (mm ²)	Bolt Size	Cable Lug Type	Note
6	M5	KST TLK6-5	If the recommended lug type is not available, use a local M5 lug type as a substitute.
8	M5	KST RNBS8-5	
10	M6	KST TLK10-6	If the recommended lug type is not available, use a local M6 lug type as a substitute.
16	M6	KST TLK16-6	
25	M6	KST DRNB6-25	
35	M6	KST TLK35-6	
50	M8	KST TLK50-8	If the recommended lug type is not available, use a local M8 lug type as a substitute.

Torque Specifications

Bolt Size	Torque
M5	4 Nm
M6	5 Nm
M8	12 Nm

Weights and Dimensions

UPS	Weight kg	Height mm	Width mm	Depth mm
10 kVA 3:1 UPS for external batteries	36	530	250	700
15 kVA 3:1 UPS for external batteries	36	530	250	700
20 kVA 3:1 UPS for external batteries	58	770	250	800
30 kVA 3:1 UPS for external batteries	60	770	250	800

Shipping Weights and Dimensions

UPS	Weight kg	Height mm	Width mm	Depth mm
10 kVA 3:1 UPS for external batteries	50	772	400	857
15 kVA 3:1 UPS for external batteries	50	772	400	857
20 kVA 3:1 UPS for external batteries	75	1015	400	982
30 kVA 3:1 UPS for external batteries	77	1015	400	982

Clearance

NOTE: Clearance dimensions are published for airflow and service access only. Consult with the local safety codes and standards for additional requirements in your local area.

NOTE: If the UPS is installed without side access (Option A*), the length of the cables connected to the UPS must allow for rolling out the UPS.

Clearance for UPS for External Batteries

Option A*

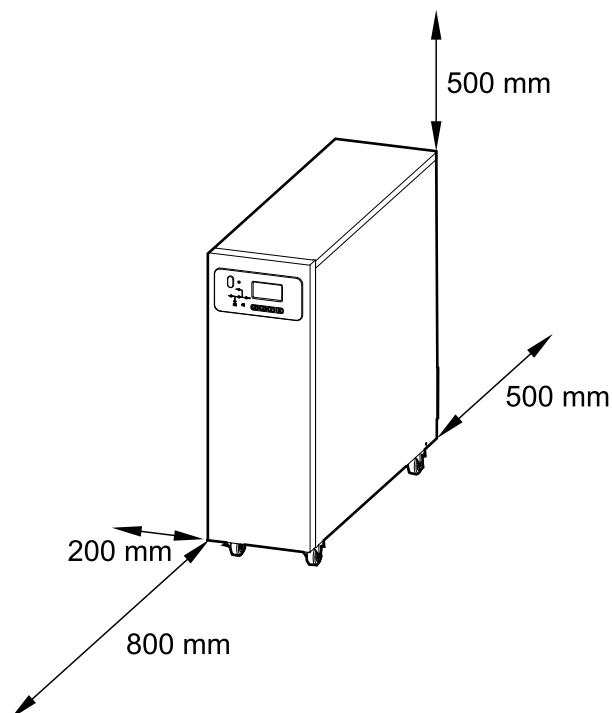

Option B

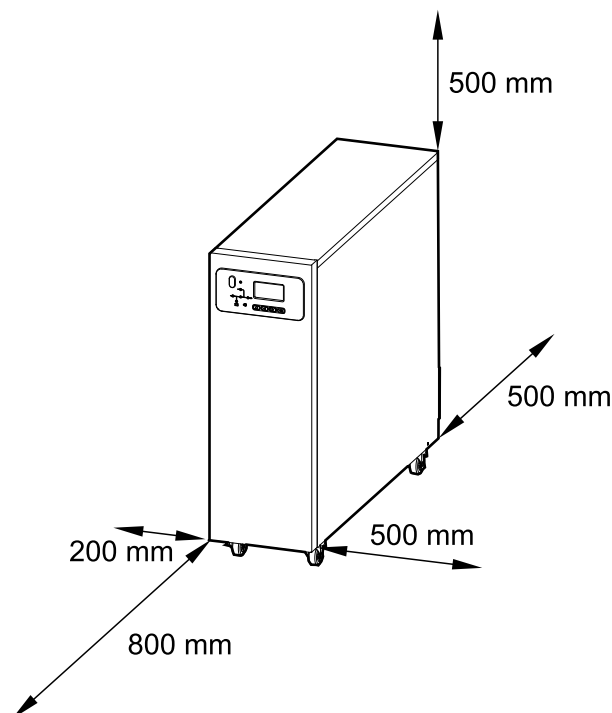

NOTE: 200 mm left side clearance is required when the UPS is placed next to a wall to allow the front door to open properly.

Environmental

	Operation	Storage
Temperature	0 °C to 40 °C 20 °C to 25 °C (optimal operation temperature for batteries)	-15 °C to 40 °C for systems with batteries -25 °C to 55 °C for systems without batteries
Relative humidity	0–95% non-condensing	
Elevation derating according to IEC 62040–3	1000 m: 1.000 1500 m: 0.975 2000 m: 0.950	< 15000 m above sea level (or in an environment with equivalent air pressure)
Audible noise	10–20 kVA 400 V: <60 dBA at full load 30–40 kVA 400 V: <63 dBA at full load 10–20 kVA 208 V: <63 dBA at full load	
Protection class	IP20 (dust filter as standard)	
Color	RAL 9003	

Compliance

Safety	IEC 62040-1:2017, Edition 2.0, Uninterruptible power systems (UPS) – Part 1: Safety requirements IEC 62040-1: 2008-6, 1st edition, Uninterruptible Power Systems (UPS) – Part 1: General and safety requirements for UPS IEC 62040-1:2013-01, 1st edition amendment 1
EMC/EMI/RFI	IEC 62040-2:2016, Edition 3.0, Uninterruptible power systems (UPS) – Part 2: Electromagnetic compatibility (EMC) requirements. IEC 62040-2:2005-10, 2nd edition, Uninterruptible Power Systems (UPS) – Part 2: Electromagnetic compatibility (EMC) requirements
Performance	IEC 62040-3: 2011-03, 2nd edition Uninterruptible Power Systems (UPS) - Part 3: Method of specifying the performance and test requirements
Markings	CE, RCM, EAC, WEEE, UKCA
Transportation	ISTA 2B
Pollution degree	2
Overvoltage category	III
Earthing system	TN, TT, or IT

Overview

Overview of Single UPS

UIB	Unit input breaker/switch
SSIB	Static switch input breaker/switch
UOB	Unit output breaker/switch
MBB	Maintenance bypass breaker/switch
BB	Battery breaker/switch

NOTE: Refer to Appendix: Switch/Breaker Details, page 38 for the disconnecting device type.

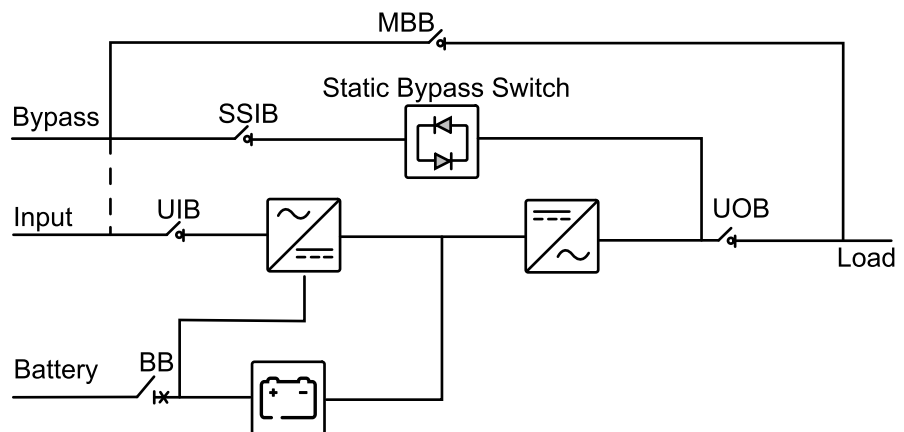

Overview of 1+1 Redundant Parallel System with Common Battery Bank

MIB	Mains input breaker/switch
BIB	Bypass input breaker/switch
UIB	Unit input breaker/switch
SSIB	Static switch input breaker/switch
UOB	Unit output breaker/switch
Ext. UOB	External unit output breaker/switch
MBB	Maintenance bypass breaker/switch
Ext. MBB	External maintenance bypass breaker/switch
BB1	Battery breaker/switch 1
BB2	Battery breaker/switch 2

NOTE: Refer to Appendix: Switch/Breaker Details, page 38 for the disconnecting device type.

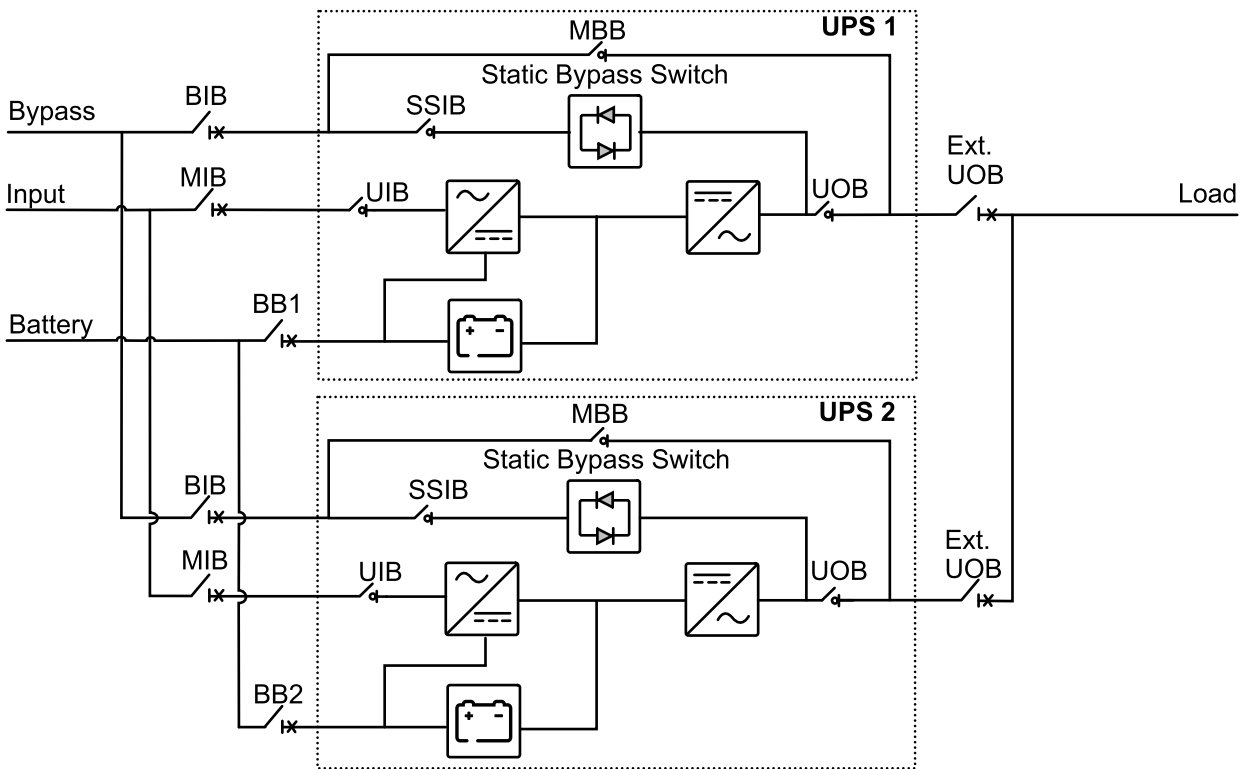

Overview of Parallel System

MIB	Mains input breaker/switch
BIB	Bypass input breaker/switch
UIB	Unit input breaker/switch Unit input switch
SSIB	Static switch input breaker/switch Static switch input switch
UOB	Unit output breaker/switch Unit output switch
Ext. UOB	External unit output breaker/switch
MBB	Maintenance bypass breaker/ switch Maintenance bypass switch
Ext. MBB	External maintenance bypass breaker/switch
SIB	System isolation breaker/switch
BB	Battery breaker/switch

NOTE: Refer to Appendix: Switch/Breaker Details, page 38 for the disconnecting device type.

NOTE: In parallel systems with an external maintenance bypass breaker Ext. MBB, the maintenance bypass breakers/switches MBB must be padlocked in the open (OFF) position.

UPSs for External Batteries

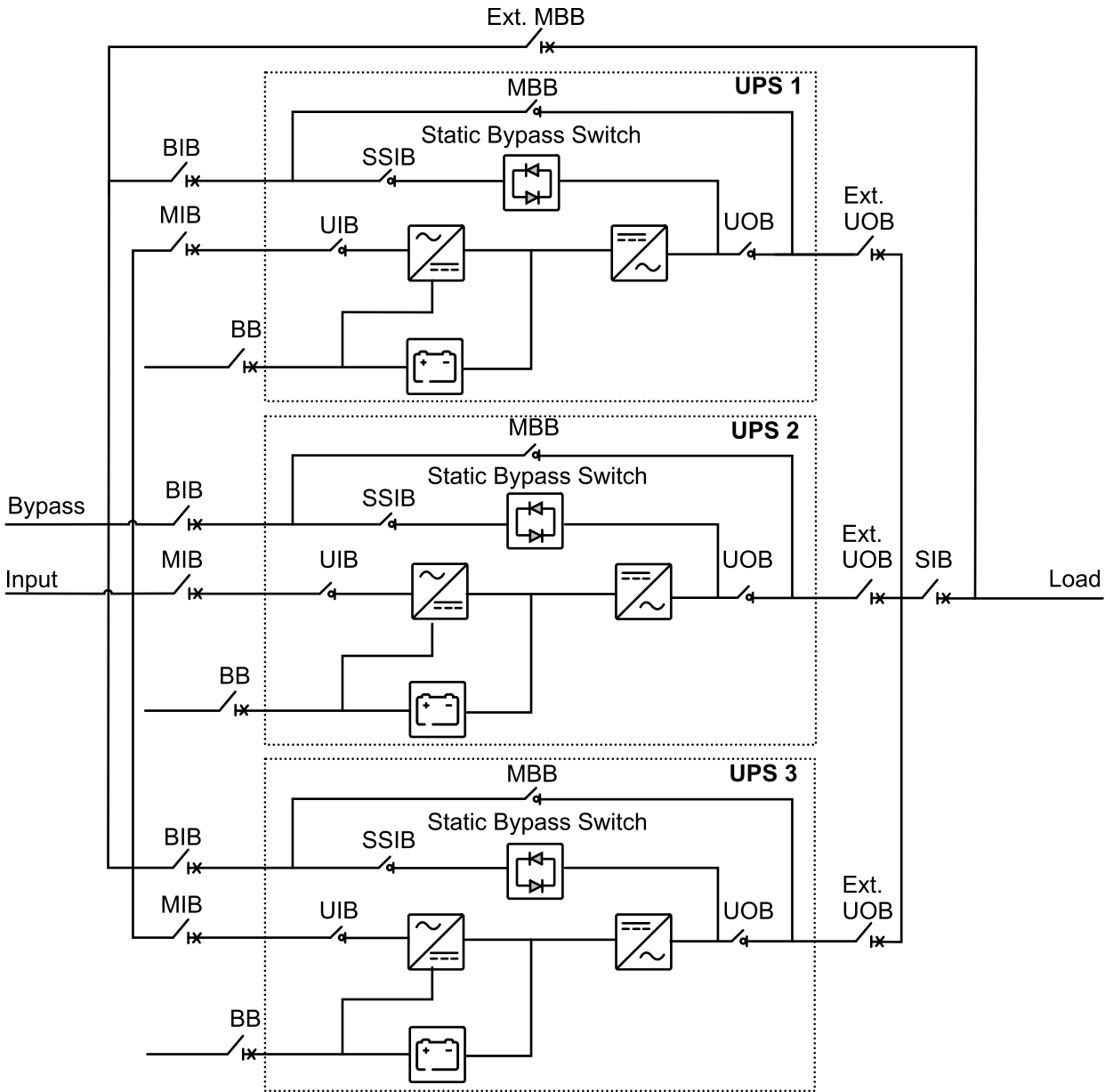

The impedance of the bypass paths need to be controlled in a parallel UPS system. When operating in bypass mode, the parallel load sharing is determined by the total impedance of the bypass path comprising cables, switchgear, static bypass switch, and cable formation.

NOTICE

RISK OF EQUIPMENT DAMAGE

To ensure correct load sharing in bypass operation in a parallel system, the following recommendations apply:

- The bypass cables must be the same length for all UPSs.
- The output cables must be the same length for all UPSs.
- The input cables must be the same length for all UPSs in a single mains system.
- Cable formation recommendations must be followed.
- The reactance of busbar layout in the bypass/input and output switchgear must be the same for all UPSs.

If the above recommendations are not followed the result can be uneven load sharing in bypass and overload of individual UPSs.

Failure to follow these instructions can result in equipment damage.

Receiving

External Inspection

When the shipment arrives, inspect the shipping material for any signs of damage or mishandling. Do not attempt to install the system if a damage is apparent. If any damage is noted, contact Schneider Electric and file a damage claim with the shipping agency within 24 hours.

Compare the components of the shipment with the bill of lading. Report any missing items to the carrier and to Schneider Electric immediately.

Verify that labelled units match the order confirmation.

Remove the UPS from the Pallet

1. Move the UPS to the final installation area using a forklift.
2. Remove the shipping materials and the ramp from the UPS.

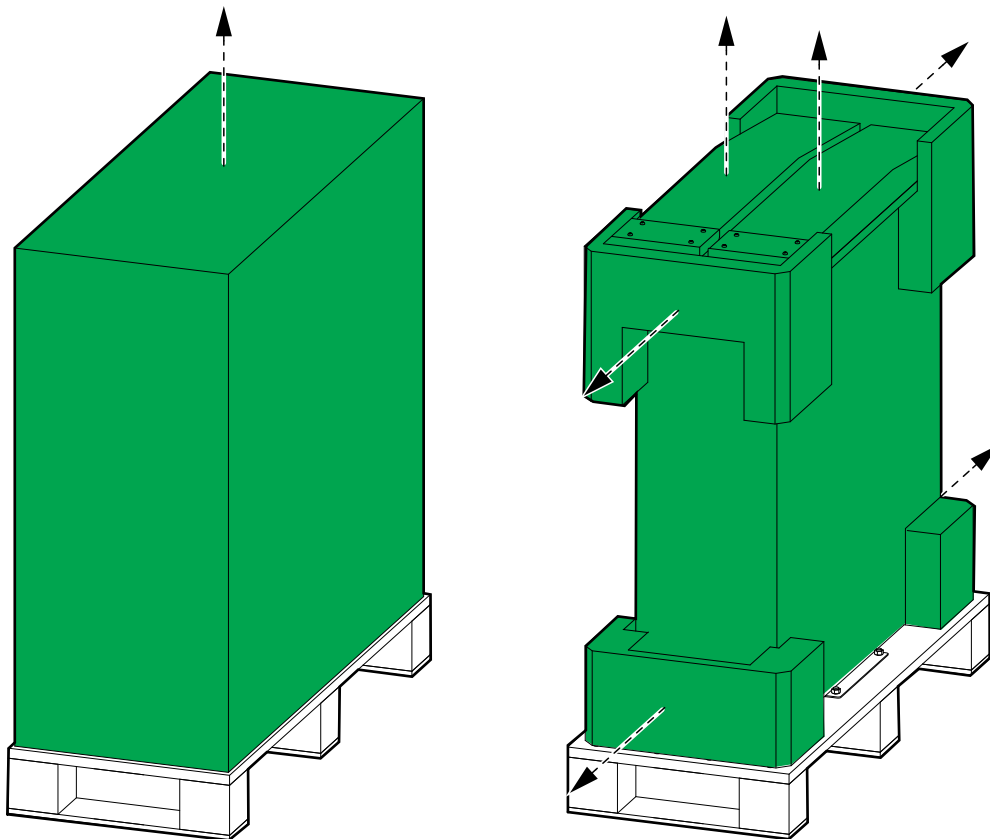

3. Place the ramp on the pallet and fasten with the provided bolts.

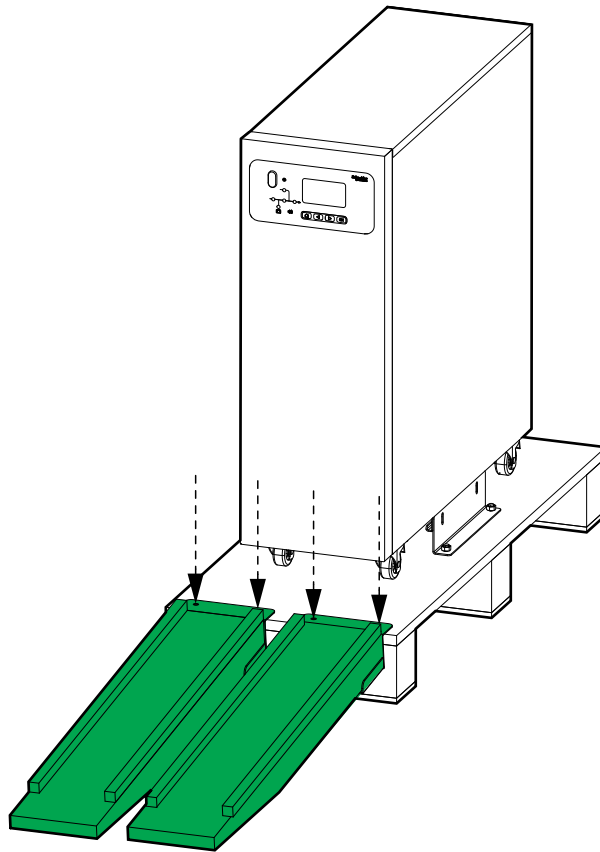

4. Loosen the bolts and remove the shipping brackets. Dispose of the shipping brackets.

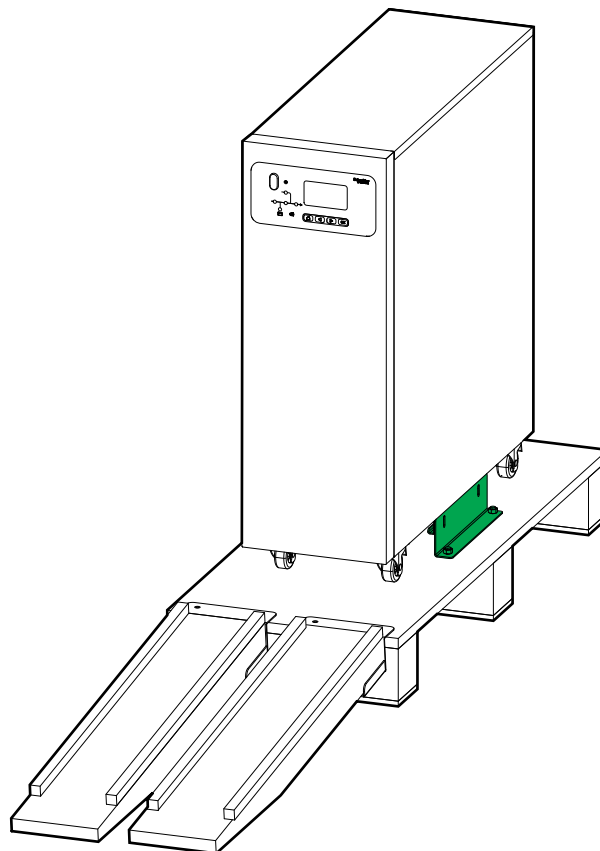

5. Roll the UPS down from the pallet.

6. Move the UPS to its final location and lock the wheels.

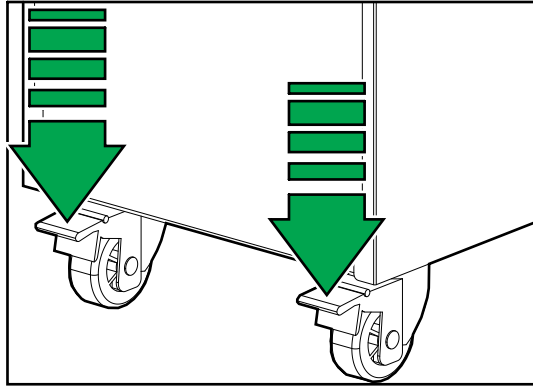

Connect the Power Cables

Connect the Power Cables in the 10-15 kVA UPS

1. Ensure that all breakers are in the OFF (open) position.
2. Remove the conduit box cover.

Rear View

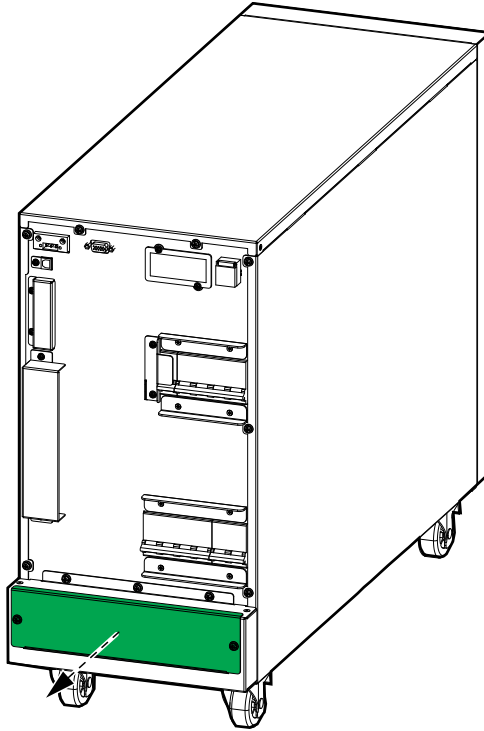

3. In dual mains systems, remove the single mains cable.

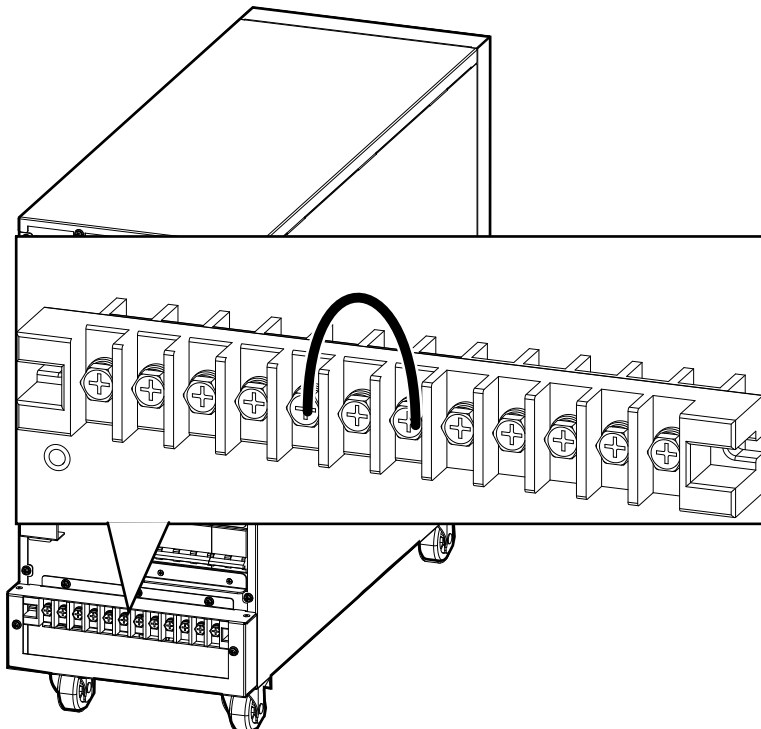

4. Route the power cables through the bottom of the conduit box.

5. Connect the PE cable to the PE terminal.

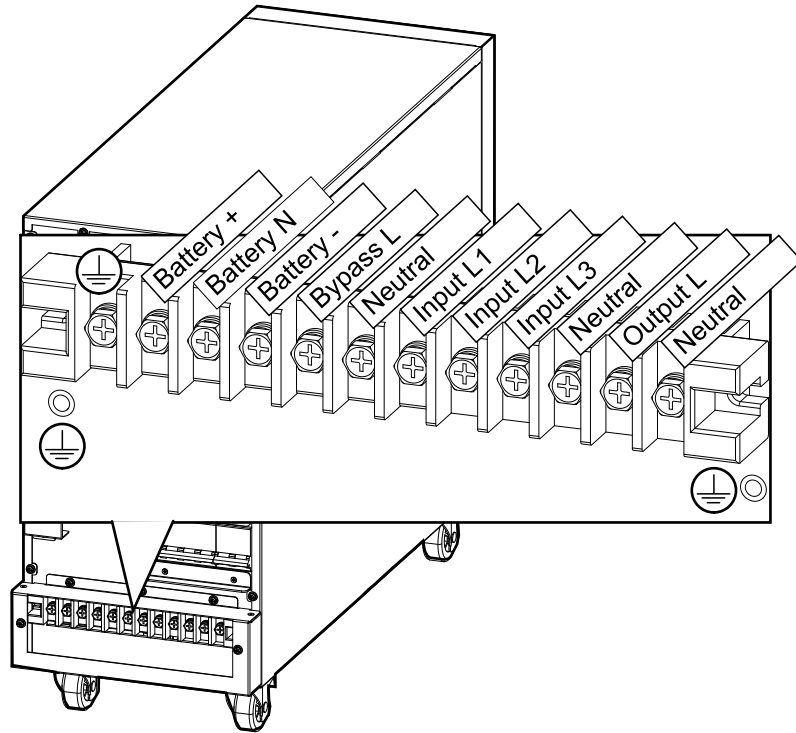

6. Connect the input, output, and bypass (if applicable) cables.
7. Connect the battery cables.
8. Reinstall the conduit box cover.

Connect the Power Cables in the 20-30 kVA UPS

1. Ensure that all breakers are in the OFF (open) position.
2. Remove the conduit box cover.

Rear View

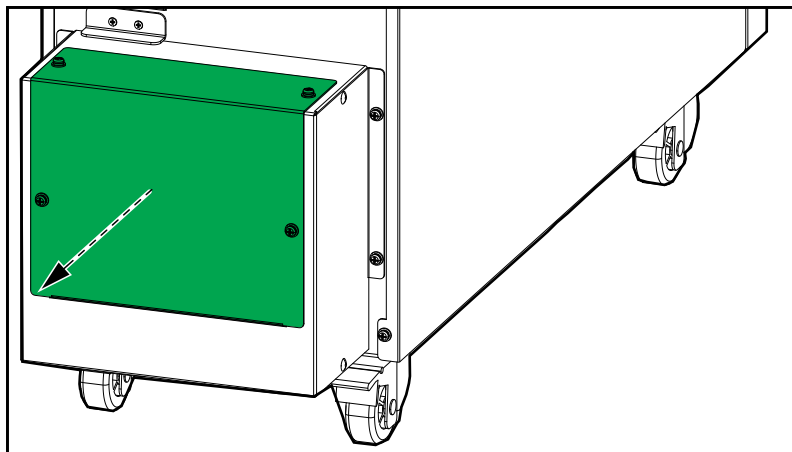

3. In dual mains systems, remove the single mains bracket.

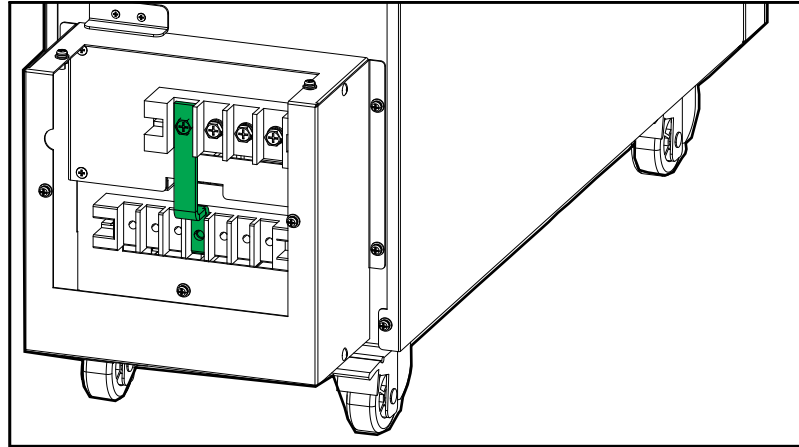

4. Route the power cables through the conduit box.
5. Connect the PE cable to the PE terminal.

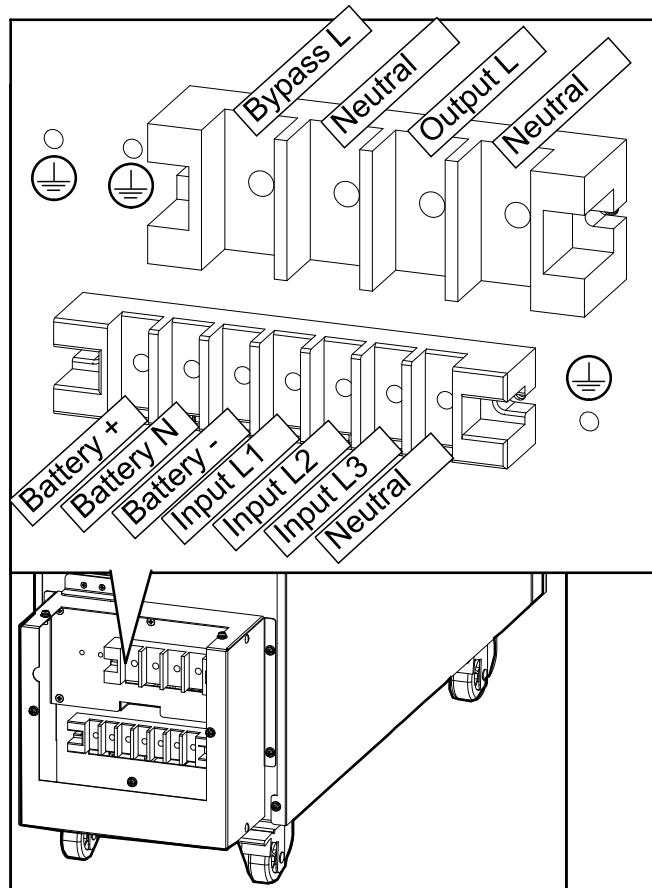

6. Connect the input, output, and bypass (if applicable) cables.
7. Connect the battery cables.
8. Reinstall the conduit box cover.

Communication Interfaces

10-15 kVA UPS

- A. Dry contacts
- B. Parallel ports
- C. USB (for service)
- D. RS485
- E. RS232 (for service)
- F. Network management card (NMC)
- G. Cold start (optional)

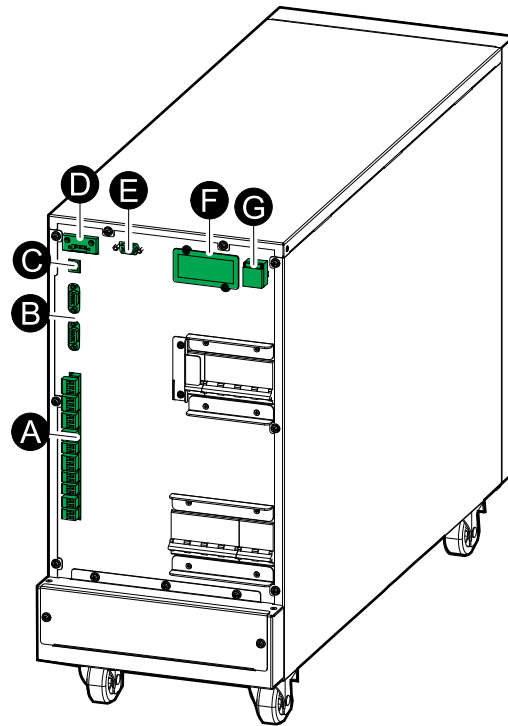

20-30 kVA UPS

- A. Dry contacts
- B. Parallel ports
- C. USB (for service)
- D. RS485
- E. RS232 (for service)
- F. Network management card (NMC)
- G. Cold start (optional)

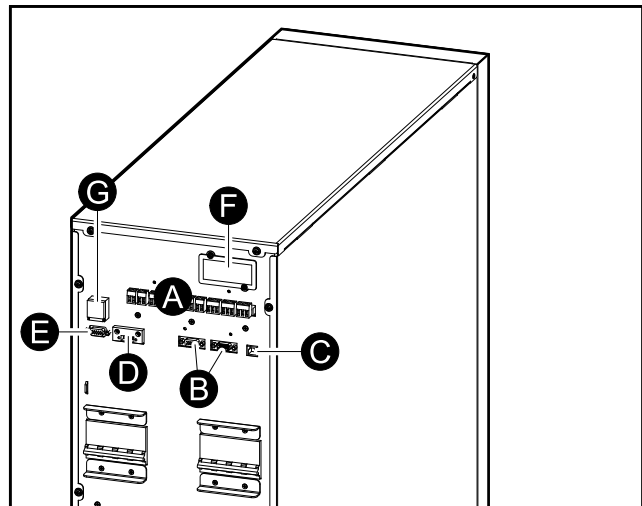

Input Contacts and Output Relays

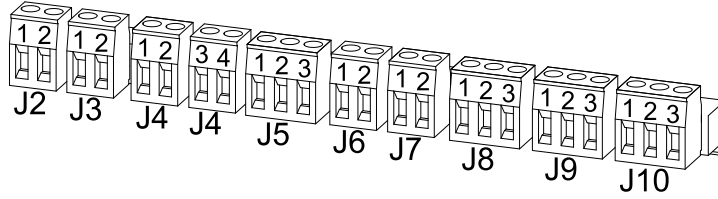

Input Contacts

NOTE: When an external battery breaker with ON/OFF status detection and trip function is used, leave the terminator installed between J7-1 and J7-2.

NOTE: Schneider Electric recommends to connect the optional temperature sensor kit E3SOPT003 (R25=5 kohm, B25/50=3275) to J2 to monitor the battery temperature.

NOTICE

RISK OF EQUIPMENT DAMAGE

- Connect the Schneider Electric shunt trip coil LV429390 to the recommended battery breaker to protect the battery.
- The battery breaker contact drive (J6-1) can provide a maximum of +24 V, 200 mA to the shunt trip coil. If this value is exceeded it can damage the UPS.

Failure to follow these instructions can result in equipment damage.

Input connections are considered 24 VDC Class 2/SELV.

Input Contacts for UPSs without Batteries

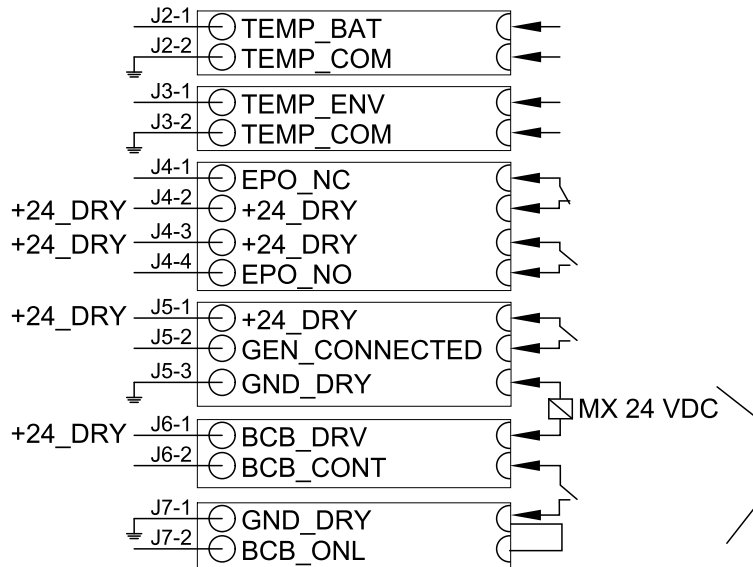

Output Relays

Output relay connection: Maximum 3A/240 VAC.

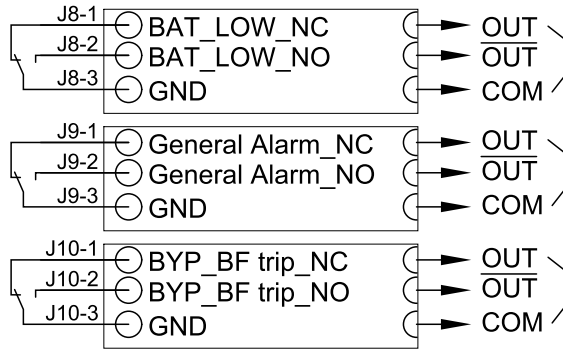

Connect the Signal Cables in Parallel Systems

1. Connect the optional parallel cables between all the UPSs of the parallel system.

NOTE: See Communication Interfaces, page 32 for location of parallel ports.

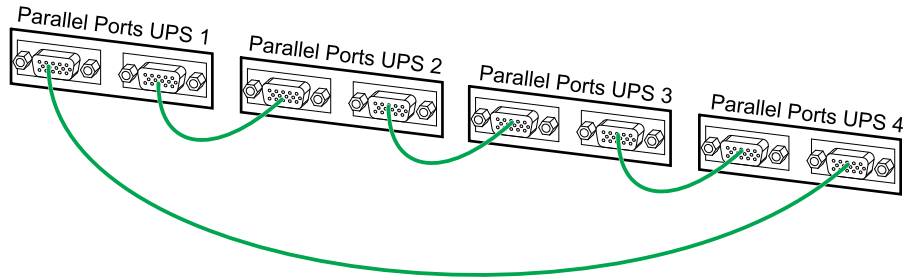

2. For 10/15/30/40 kVA UPSs, remove the right side panel of the UPSs. For 20 kVA UPSs, remove the left side panel of the UPSs. Pull out the parallel board.
3. Remove the jumpers from the parallel board according to your system:
 - In parallel systems with two UPSs, remove the jumpers from J34, J36, J38, J39, J42 on both boards.
 - In parallel systems with three or four UPSs, remove all the jumpers.

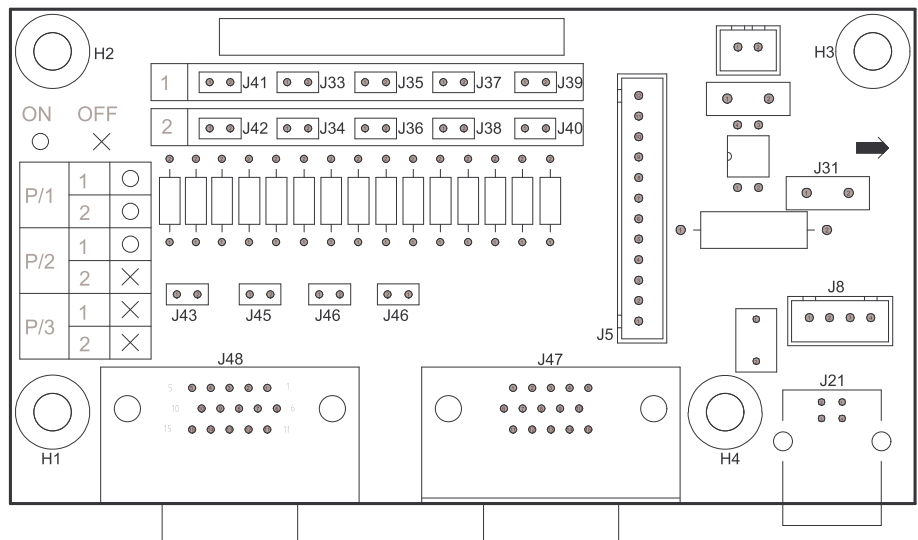

Backfeed Protection

⚠ DANGER

HAZARD OF ELECTRIC SHOCK, EXPLOSION, OR ARC FLASH

In systems where backfeed protection is not part of the standard design, an automatic isolation device (backfeed protection option or other device meeting the requirements of IEC/EN 62040–1) must be installed to prevent hazardous voltage or energy at the input terminals of the isolation device. The device must open within 15 seconds after the upstream power supply fails and must be rated according to the specifications.

Failure to follow these instructions will result in death or serious injury.

When the UPS input is connected through external isolators that, when opened, isolate the neutral or when the automatic backfeed isolation is provided external to the equipment or is connected to an IT power distribution system, a label must be fitted at the UPS input terminals, and on all primary power isolators installed remote from the UPS area and on external access points between such isolators and the UPS, by the user, displaying the following text (or equivalent in a language which is acceptable in the country in which the UPS system is installed):

⚠ DANGER

HAZARD OF ELECTRIC SHOCK, EXPLOSION, OR ARC FLASH

Risk of Voltage Backfeed. Before working on this circuit: Isolate the UPS and check for hazardous voltage between all terminals including the protective earth.

Failure to follow these instructions will result in death or serious injury.

An additional external isolation device must be installed in the UPS system. A magnetic contactor or a circuit breaker with UVR (Under Voltage Release) functionality can be used for this purpose. In the shown examples, the isolation device is a magnetic contactor (marked with a **MC1** for single mains systems and marked with a **MC1** and **MC2** for dual mains systems).

The isolation device must be able to withstand the electrical characteristics as described in Input Specifications, page 13.

NOTE: The 24 V source should be generated from the input source in single mains configurations and from the both the input and bypass source in dual mains configurations.

Single Mains UPS and External Isolation Device

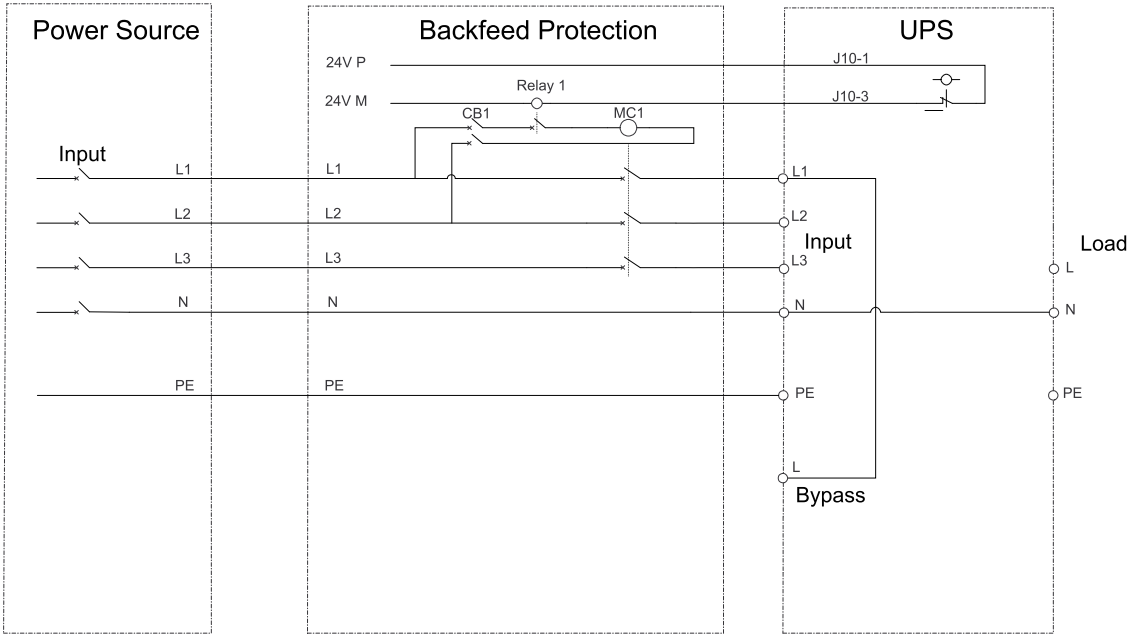

Single Mains UPS with Backfeed Box

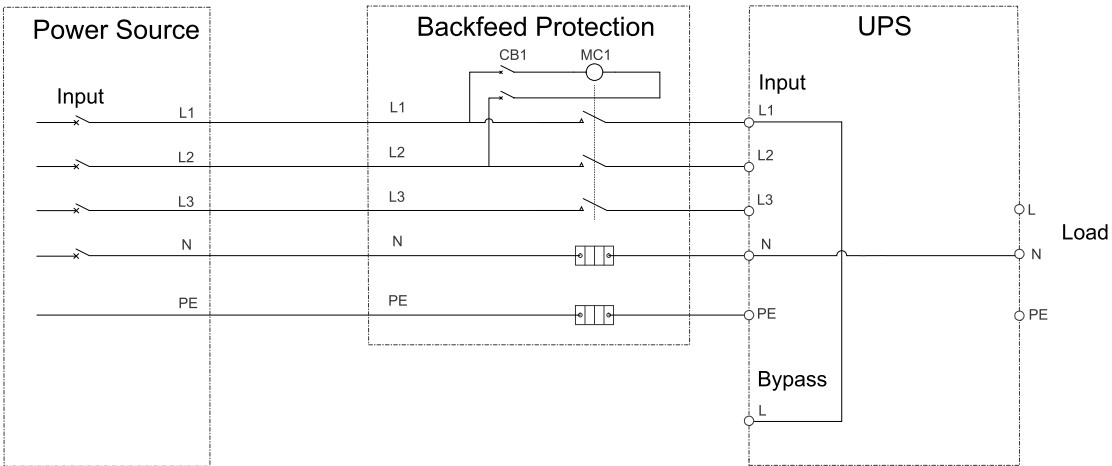

Dual Mains UPS and External Isolation Device

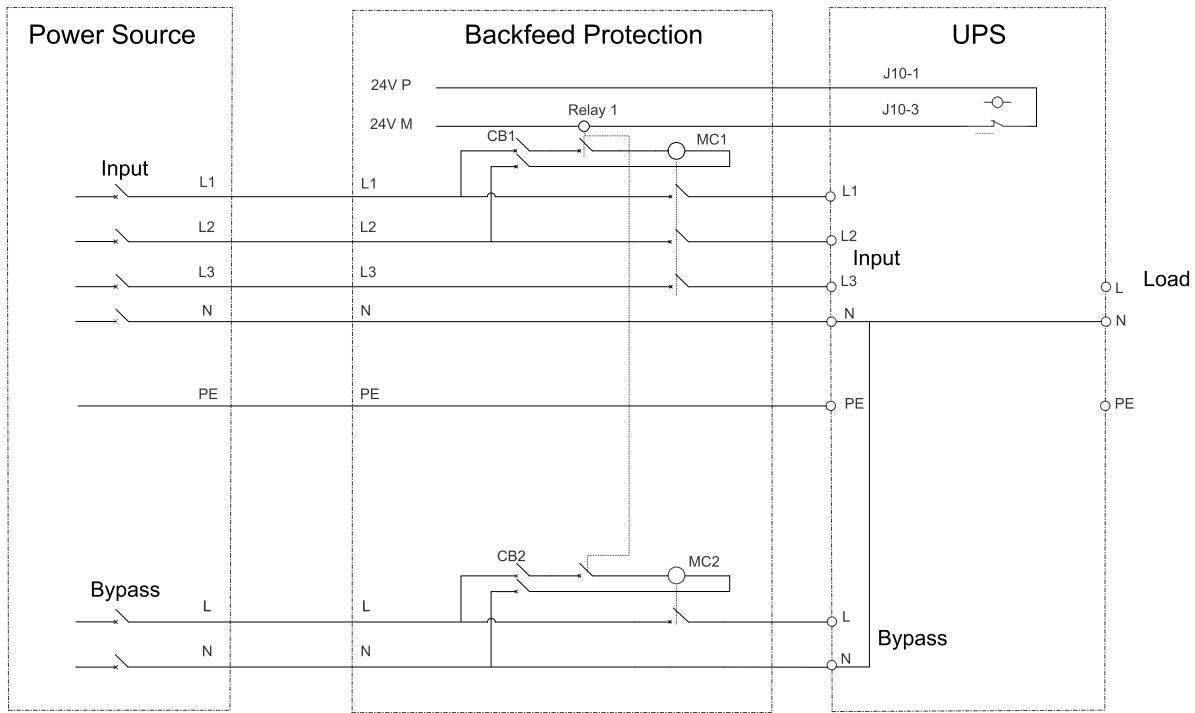

Dual Mains with Backfeed Box

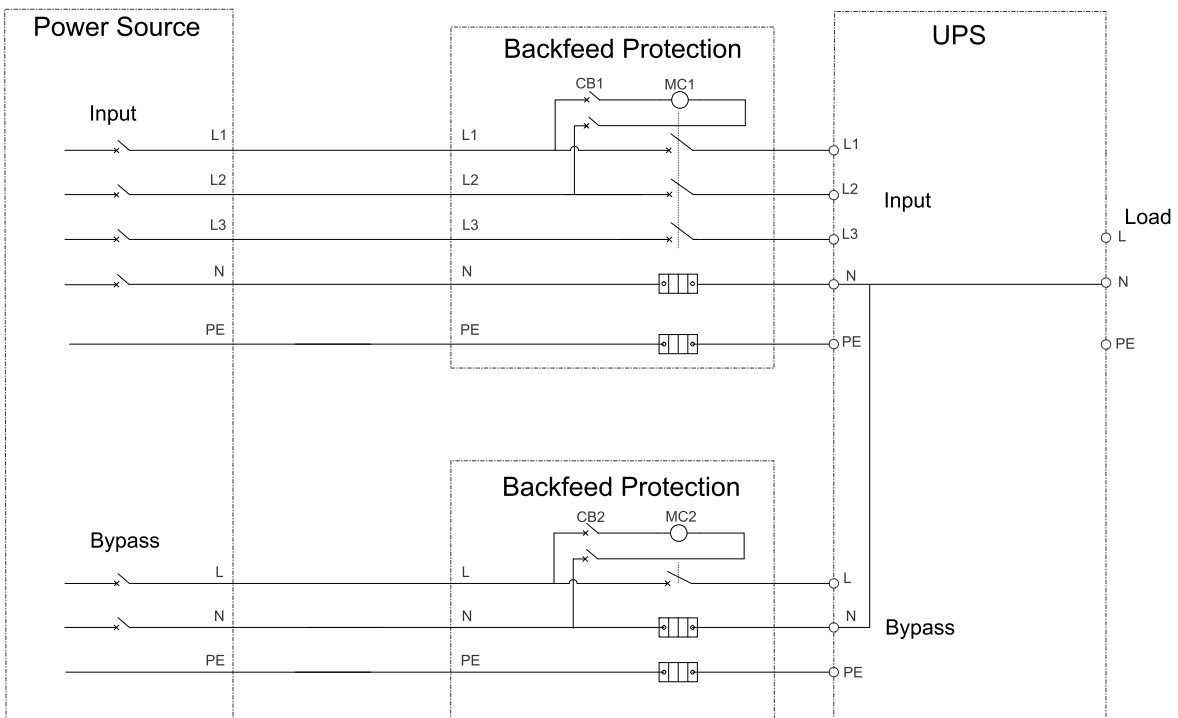

Appendix: Switch/Breaker Details

3:1 UPS

	Model	Switch/Breaker	Description	Switch or Breaker
10 kVA	UIB	OSMC65H4C32	32A 4P	Breaker
	SIB	OSMC65H4C32	32A 4P	Breaker
	UOB	A9S68263	63A 2P	Switch
	MBB	A9S68163	63A 1P	Switch
	BB	A9S68332	32A 3P	Switch (for UPSs with internal batteries)
15 kVA	UIB	OSMC65H4C40	40A 4P	Breaker
	SIB	OSMC65H4C40	40A 4P	Breaker
	UOB	A9S68280	80A 2P	Switch
	MBB	A9S68180	80A 1P	Switch
	BB	A9S68363	63A 3P	Switch (for UPSs with internal batteries)
20 kVA	UIB	OSMC65H4C63	63A 4P	Breaker
	SIB	OSMC65H4C63	63A 4P	Breaker
	UOB	A9S68292	125A 2P	Switch
	MBB	A9S68192	125A 1P	Switch
	BB	A9S68363	63A 3P	Switch (for UPSs with internal batteries)
30 kVA	UIB	A9S68480	500VAC 80A 4P	Switch
	SIB	A9S68491	100A 4P	Switch
	UOB	A9S68491	100A 4P	Switch
	MBB	A9S68280	80A 2P	Switch
	BB	A9S68391	100A 3P	Switch (for UPSs with internal batteries)

Schneider Electric
35 rue Joseph Monier
92500 Rueil Malmaison
France

+ 33 (0) 1 41 29 70 00



As standards, specifications, and design change from time to time,
please ask for confirmation of the information given in this publication.

© 2018 – 2023 Schneider Electric. All rights reserved.

990-91191E-001