

FRONT VIEW

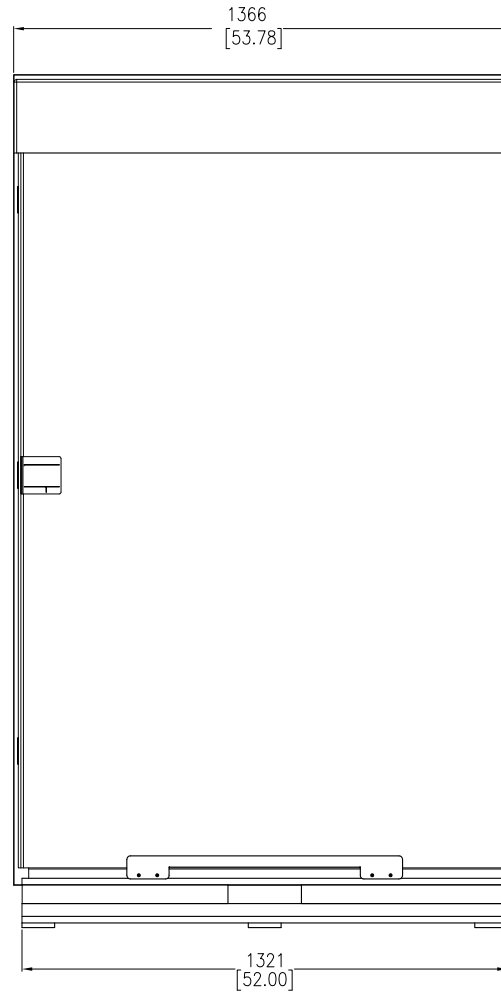

LEFT SIDE VIEW

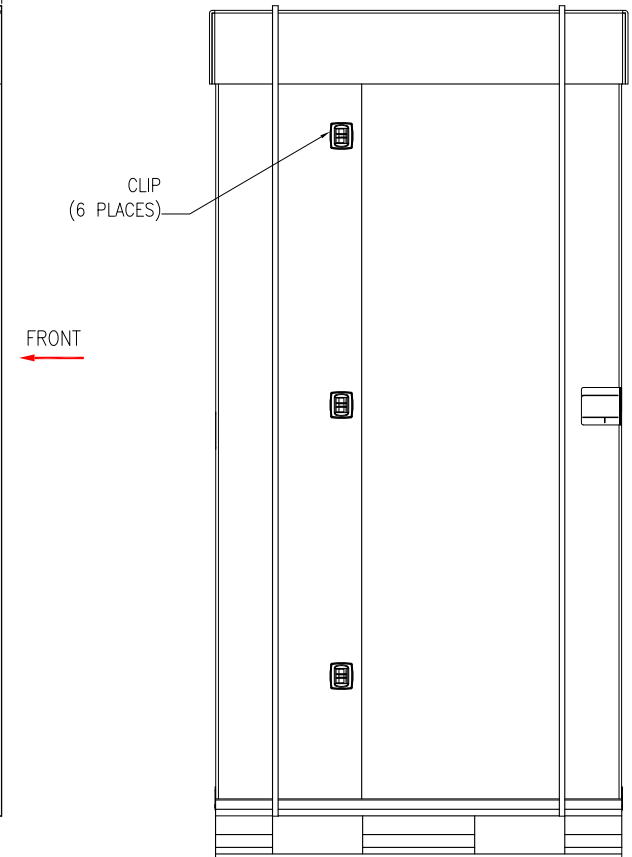

REAR VIEW

- NOTES:
1. INSTALLATION SHALL COMPLY WITH ALL APPLICABLE NATIONAL, STATE AND LOCAL ELECTRICAL REGULATIONS.
 2. REFER TO PRODUCT DOCUMENTATION FOR ADDITIONAL DETAILS PRIOR TO INSTALLATION AND SITE PREPARATION WORK.
 3. ALL DIMENSIONS ARE IN MILLIMETERS [INCHES].
 4. SHIPPING WEIGHT OF UNIT IS 288 kg [636 LBS].

THIS DRAWING AND SPECIFICATIONS HEREIN ARE THE PROPERTY OF SCHNEIDER ELECTRIC AND SHALL NOT BE COPIED, REPRODUCED OR USED IN WHOLE OR IN PART, AS THE BASIS FOR THE MANUFACTURE OR SALE OF ITEMS WITHOUT WRITTEN PERMISSION FROM SCHNEIDER ELECTRIC. THIS DRAWING IS BASED UPON LATEST AVAILABLE INFORMATION AND IS SUBJECT TO CHANGE WITHOUT NOTICE.



TITLE: NetShelter SX 45U
750mm WIDE X 1200mm DEEP
ENCLOSURE WITH SIDES-SHOCK PACKAGING
PACKING DETAILS

PROJECT: SUBMITTAL DRAWINGS SHEET 1 OF 6

DWG NO: AR3355SP REV: 0

DRAWN BY: JAYAPRAKASH 03-JULY-15 FIRST ANGLE PROJECTION

ENGINEER: D HUDSON/ R PHILLIPS 06-JUL-15

APPROVED BY: GREG IVEY 06-JUL-15

UNPACKING AND UNLOADING STEPS

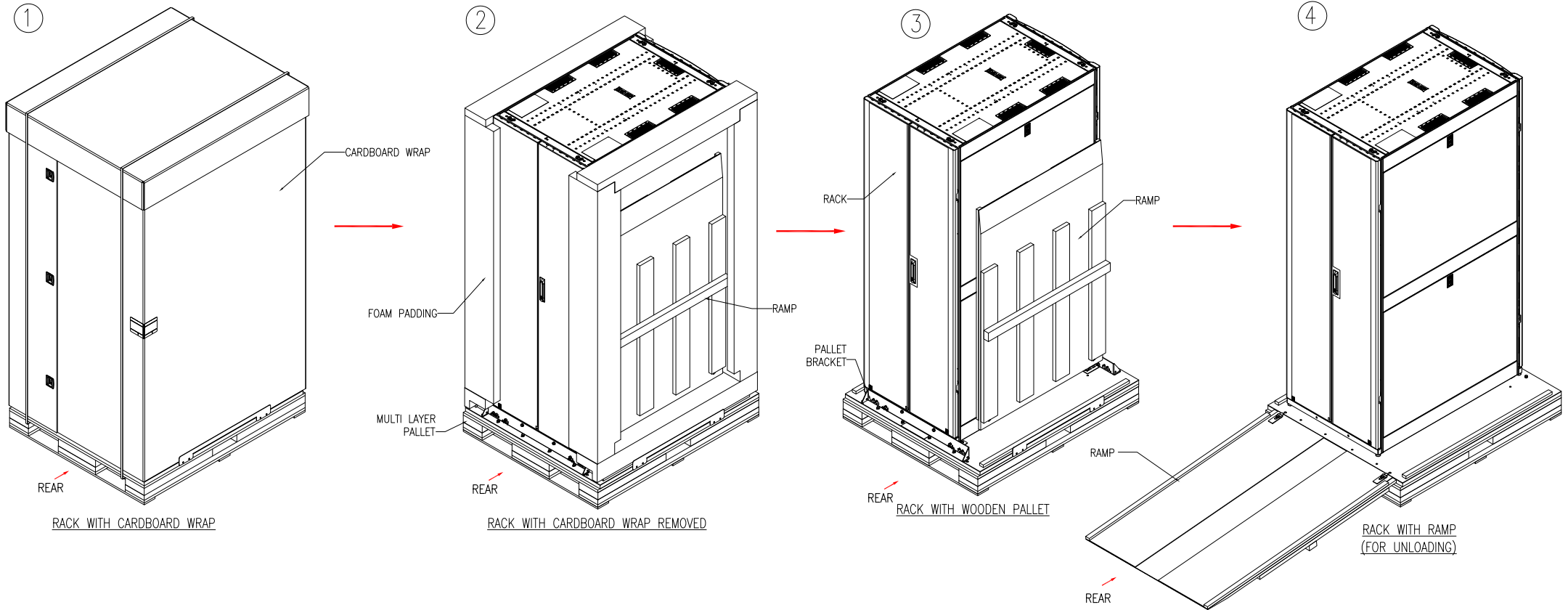

NOTES:
 1. INSTALLATION SHALL COMPLY WITH ALL APPLICABLE NATIONAL, STATE AND LOCAL ELECTRICAL REGULATIONS.
 2. REFER TO PRODUCT DOCUMENTATION FOR ADDITIONAL DETAILS PRIOR TO INSTALLATION AND SITE PREPARATION WORK.

THIS DRAWING AND SPECIFICATIONS HEREIN ARE THE PROPERTY OF SCHNEIDER ELECTRIC AND SHALL NOT BE COPIED, REPRODUCED OR USED IN WHOLE OR IN PART, AS THE BASIS FOR THE MANUFACTURE OR SALE OF ITEMS WITHOUT WRITTEN PERMISSION FROM SCHNEIDER ELECTRIC. THIS DRAWING IS BASED UPON LATEST AVAILABLE INFORMATION AND IS SUBJECT TO CHANGE WITHOUT NOTICE.



TITLE: NetShelter SX 45U
 750mm WIDE X 1200mm DEEP
 ENCLOSURE WITH SIDES-SHOCK PACKAGING
 ISOMETRIC VIEWS

DWG NO: AR3355SP

REV. 1

DRAWN BY: JAYAPRAKASH 14-JUL-17
 ENGINEER: JIE ZHU 14-JUL-17

FIRST ANGLE PROJECTION

PROJECT: SUBMITTAL DRAWINGS SHEET 2 OF 6

APPROVED BY: GREG IVEY 14-JUL-17

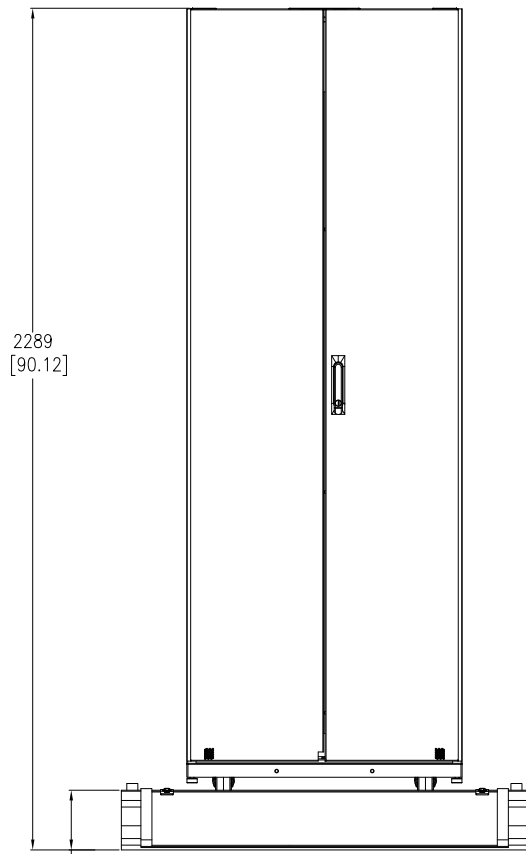

2289
[90.12]

162
[6.39]

REAR VIEW

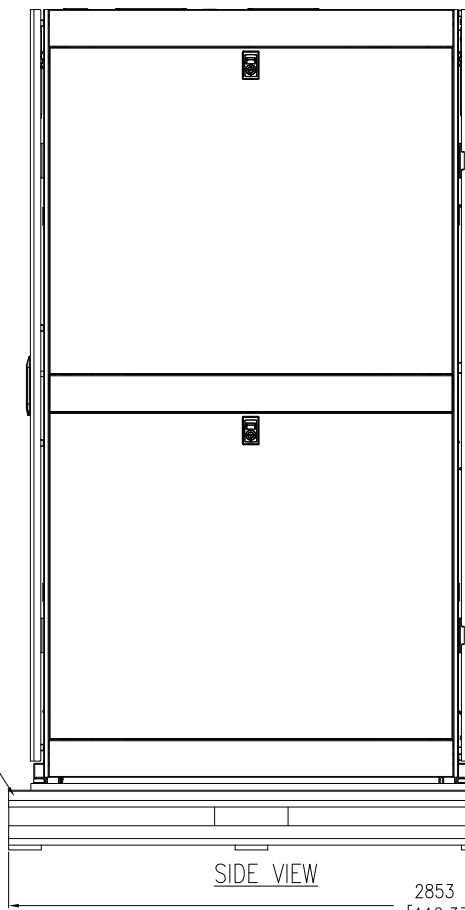

REAR
←

MULTI LAYER
PALLET

RAMP

SIDE VIEW

2853
[112.33]

5°

1222
[48.11]
MINIMUM CLEARANCE
REQUIRED FOR
UNLOADING

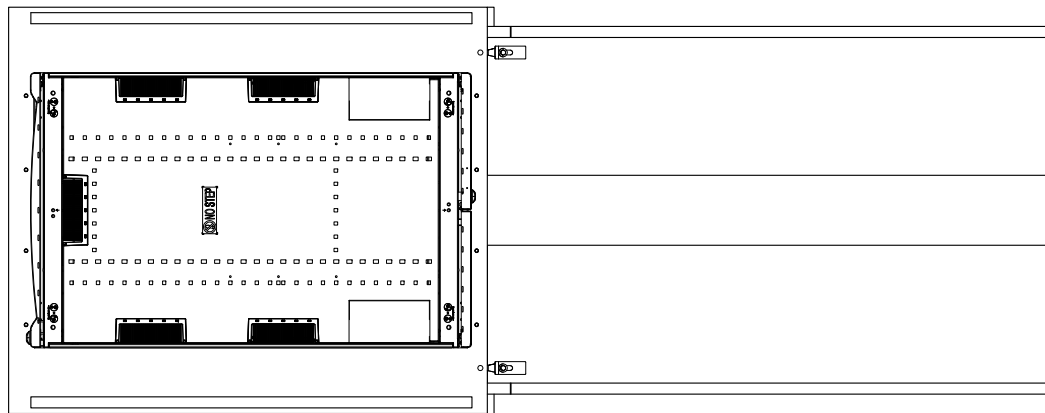

RAMP

TOP VIEW

- NOTES:**
1. INSTALLATION SHALL COMPLY WITH ALL APPLICABLE NATIONAL, STATE AND LOCAL ELECTRICAL REGULATIONS.
 2. REFER TO PRODUCT DOCUMENTATION FOR ADDITIONAL DETAILS PRIOR TO INSTALLATION AND SITE PREPARATION WORK.
 3. ALL DIMENSIONS ARE IN MILLIMETERS [INCHES].

THIS DRAWING AND SPECIFICATIONS HEREIN ARE THE PROPERTY OF SCHNEIDER ELECTRIC AND SHALL NOT BE COPIED, REPRODUCED OR USED IN WHOLE OR IN PART, AS THE BASIS FOR THE MANUFACTURE OR SALE OF ITEMS WITHOUT WRITTEN PERMISSION FROM SCHNEIDER ELECTRIC. THIS DRAWING IS BASED UPON LATEST AVAILABLE INFORMATION AND IS SUBJECT TO CHANGE WITHOUT NOTICE.



TITLE:
NetShelter SX 45U
ENCLOSURE WITH SIDES-SHOCK PACKAGING
UNLOADING DETAILS

DWG NO: AR3355SP

REV. 1

DRAWN BY: JAYAPRAKASH 14-JUL-17

FIRST

ENGINEER: JIE ZHU 14-JUL-17

ANGLE

PROJECT: SUBMITTAL DRAWINGS SHEET 3 OF 6

APPROVED BY: GREG IVEY 14-JUL-17

PROJECTION

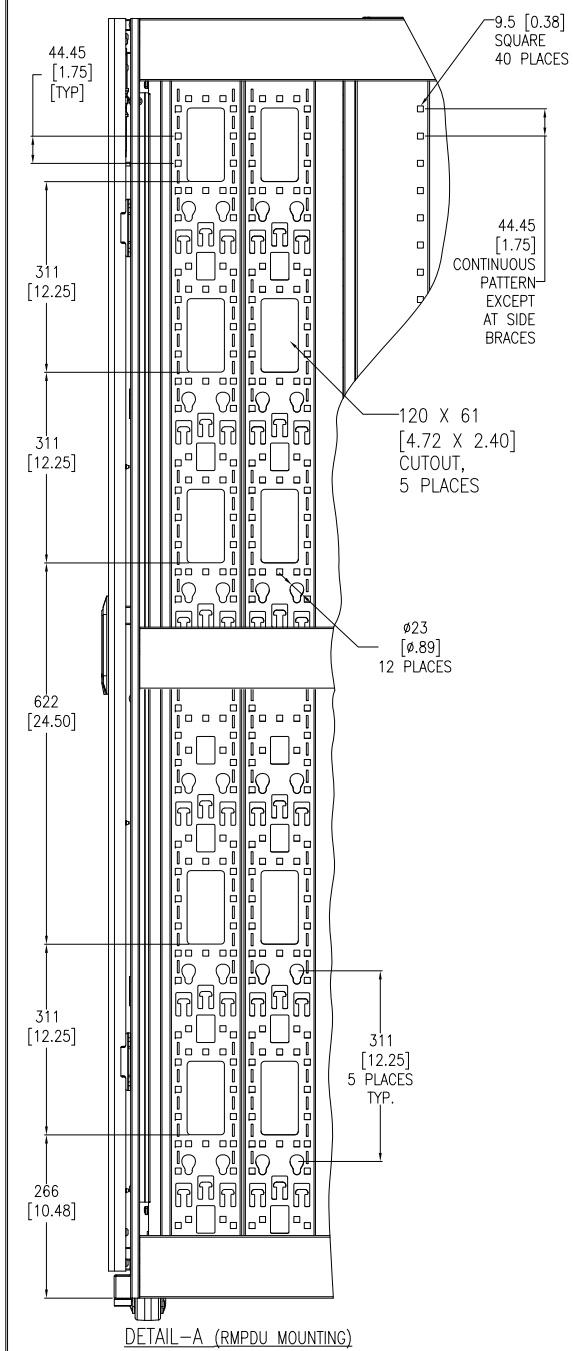
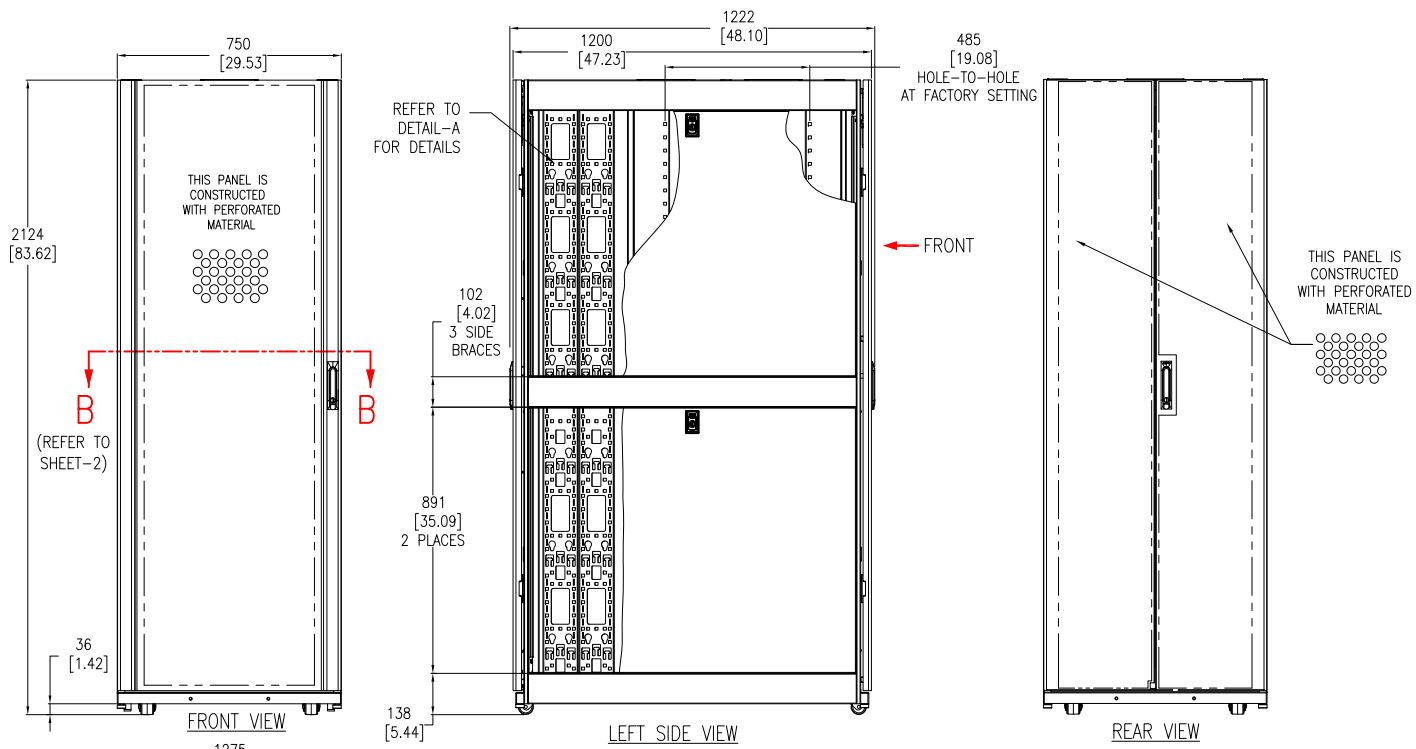

- NOTES:
1. INSTALLATION SHALL COMPLY WITH ALL APPLICABLE NATIONAL, STATE AND LOCAL ELECTRICAL REGULATIONS.
 2. REFER TO PRODUCT DOCUMENTATION FOR ADDITIONAL DETAILS PRIOR TO INSTALLATION AND SITE PREPARATION WORK.
 3. ALL DIMENSIONS ARE IN MILLIMETERS [INCHES].
 4. NET WEIGHT OF UNIT IS 169Kg [371.8 lb].
 5. MAXIMUM INSTALLED EQUIPMENT WEIGHT IS 907kg [2000 lb].
 6. CABLE ENTRY IS TOP OR BOTTOM OF THE UNIT.
 7. FRONT AND REAR SERVICE ACCESS REQUIRED.
 8. AIR FLOW AND SERVICE REQUIREMENTS, AS WELL AS MINIMUM CLEARANCE TO FIRE SUPPRESSION SYSTEMS SHOULD BE CONSIDERED WHEN LOCATING THE ENCLOSURE.

THIS DRAWING AND SPECIFICATIONS HEREIN ARE THE PROPERTY OF SCHNEIDER ELECTRIC AND SHALL NOT BE COPIED, REPRODUCED OR USED IN WHOLE OR IN PART, AS THE BASIS FOR THE MANUFACTURE OR SALE OF ITEMS WITHOUT WRITTEN PERMISSION FROM SCHNEIDER ELECTRIC. THIS DRAWING IS BASED UPON LATEST AVAILABLE INFORMATION AND IS SUBJECT TO CHANGE WITHOUT NOTICE.



TITLE:	NetShelter SX 45U 750mm WIDE X 1200mm DEEP ENCLOSURE WITH SIDES-SHOCK PACKAGING GENERAL ARRANGEMENT	DWG NO:	AR3355SP	REV:	1
PROJECT:	SUBMITTAL DRAWINGS	DRAWN BY:	JAYAPRAKASH	14-JUL-17	FIRST ANGLE PROJECTION
SHEET:	4 OF 6	ENGINEER:	JIE ZHU	14-JUL-17	
		APPROVED BY:	GREG IVEY	14-JUL-17	

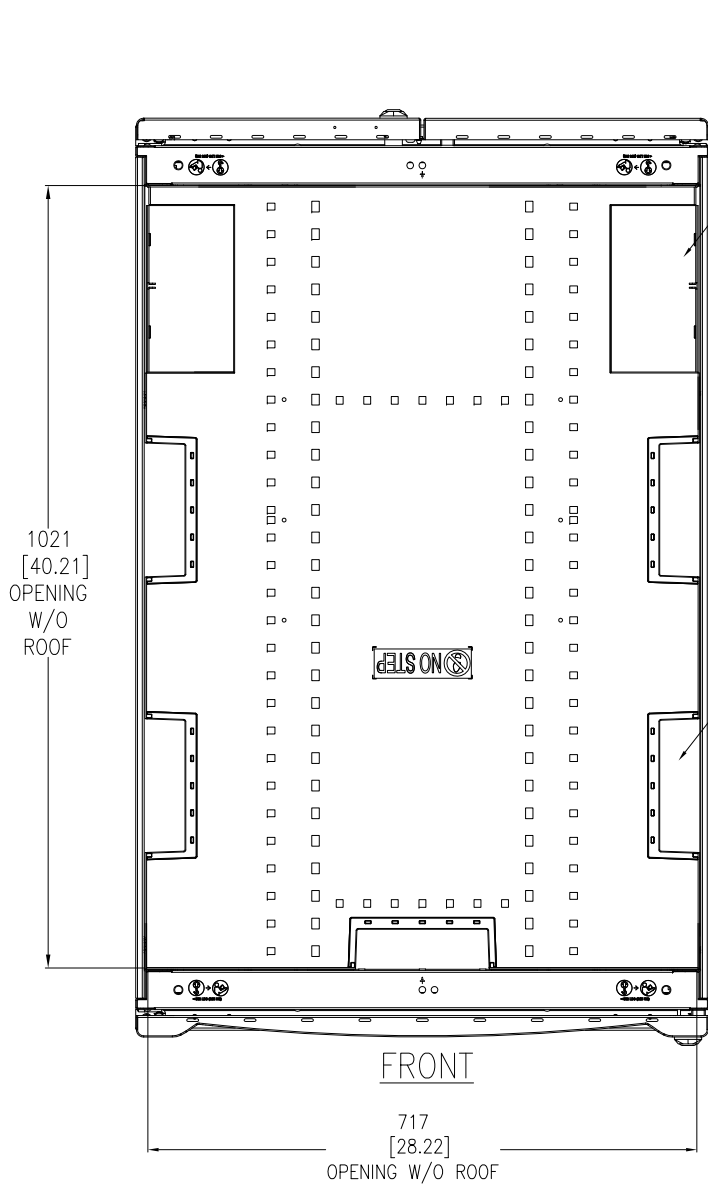

TOP VIEW
CABLE OPENINGS
(COVERS REMOVED)

220 [8.66] x 117 [4.61]
OPENING (2 PLACES)
BRUSHES ARE INCLUDED
AT EACH OF THE 2
OPENINGS.

171 [6.73] x 51 [2.02]
OPENING (5 PLACES)
BRUSHES ARE INCLUDED
AT EACH OF THE 5
OPENINGS.

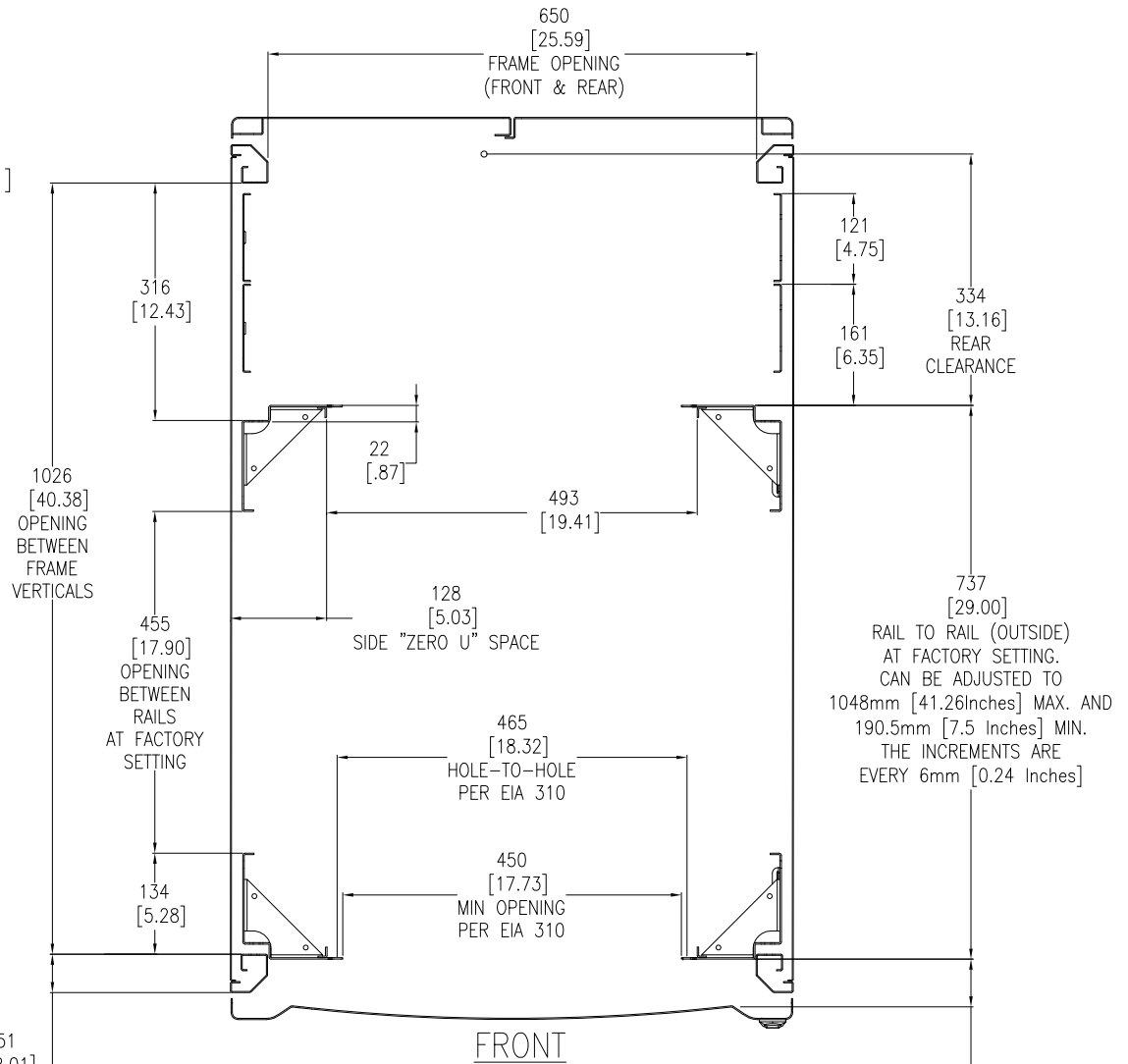

SECTION B-B
STANDARD POSITIONS FOR
MOUNTING RAILS AND
THEIR ADJUSTABILITY
(LOOKING DOWN)

737 [29.00]
RAIL TO RAIL (OUTSIDE)
AT FACTORY SETTING.
CAN BE ADJUSTED TO
1048mm [41.26Inches] MAX. AND
190.5mm [7.5 Inches] MIN.
THE INCREMENTS ARE
EVERY 6mm [0.24 Inches]

64 [2.50]
FRONT BEZEL
CLEARANCE
CAN BE ADJUSTED TO
915mm [36.02 Inches] MAX. AND
57.8mm [2.28 Inches] MIN.
THE INCREMENTS
ARE EVERY 6mm [0.24 Inches]

- NOTES:
1. INSTALLATION SHALL COMPLY WITH ALL APPLICABLE NATIONAL, STATE AND LOCAL ELECTRICAL REGULATIONS.
 2. REFER TO PRODUCT DOCUMENTATION FOR ADDITIONAL DETAILS PRIOR TO INSTALLATION AND SITE PREPARATION WORK.
 3. ALL DIMENSIONS ARE IN MILLIMETERS [INCHES].

THIS DRAWING AND SPECIFICATIONS HEREIN ARE THE PROPERTY OF SCHNEIDER ELECTRIC AND SHALL NOT BE COPIED, REPRODUCED OR USED IN WHOLE OR IN PART, AS THE BASIS FOR THE MANUFACTURE OR SALE OF ITEMS WITHOUT WRITTEN PERMISSION FROM SCHNEIDER ELECTRIC. THIS DRAWING IS BASED UPON LATEST AVAILABLE INFORMATION AND IS SUBJECT TO CHANGE WITHOUT NOTICE.



TITLE: NetShelter SX 45U
750mm WIDE X 1200mm DEEP
ENCLOSURE WITH SIDES-SHOCK PACKAGING
TOP VIEW & SECTION VIEW

PROJECT: SUBMITTAL DRAWINGS SHEET 5 OF 6

DWG NO: AR3355SP REV. 1
DRAWN BY: JAYAPRAKASH 14-JUL-17 FIRST ANGLE
ENGINEER: JIE ZHU 14-JUL-17 PROJECTION
APPROVED BY: GREG MEY 14-JUL-17

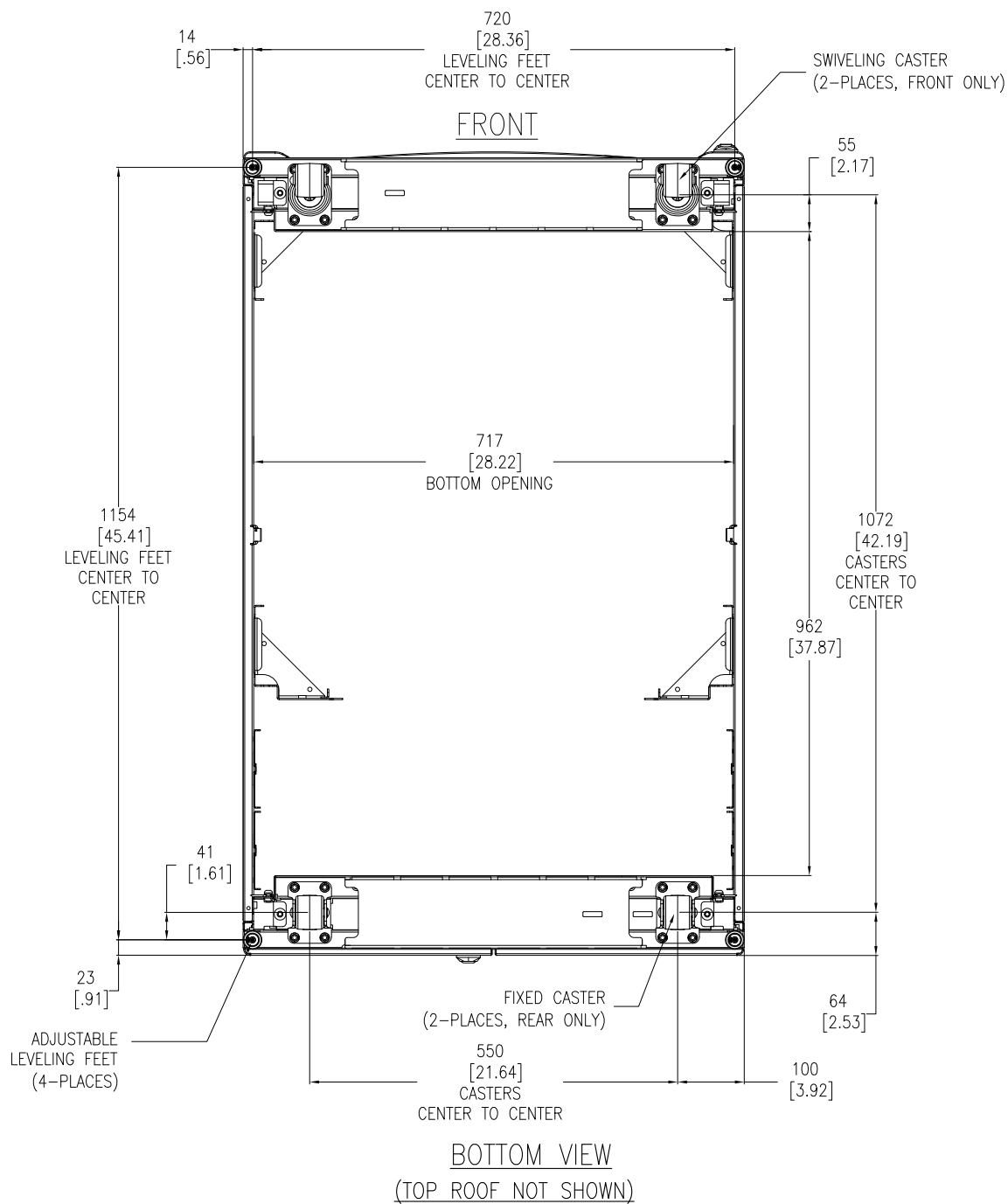

BOTTOM VIEW
(TOP ROOF NOT SHOWN)

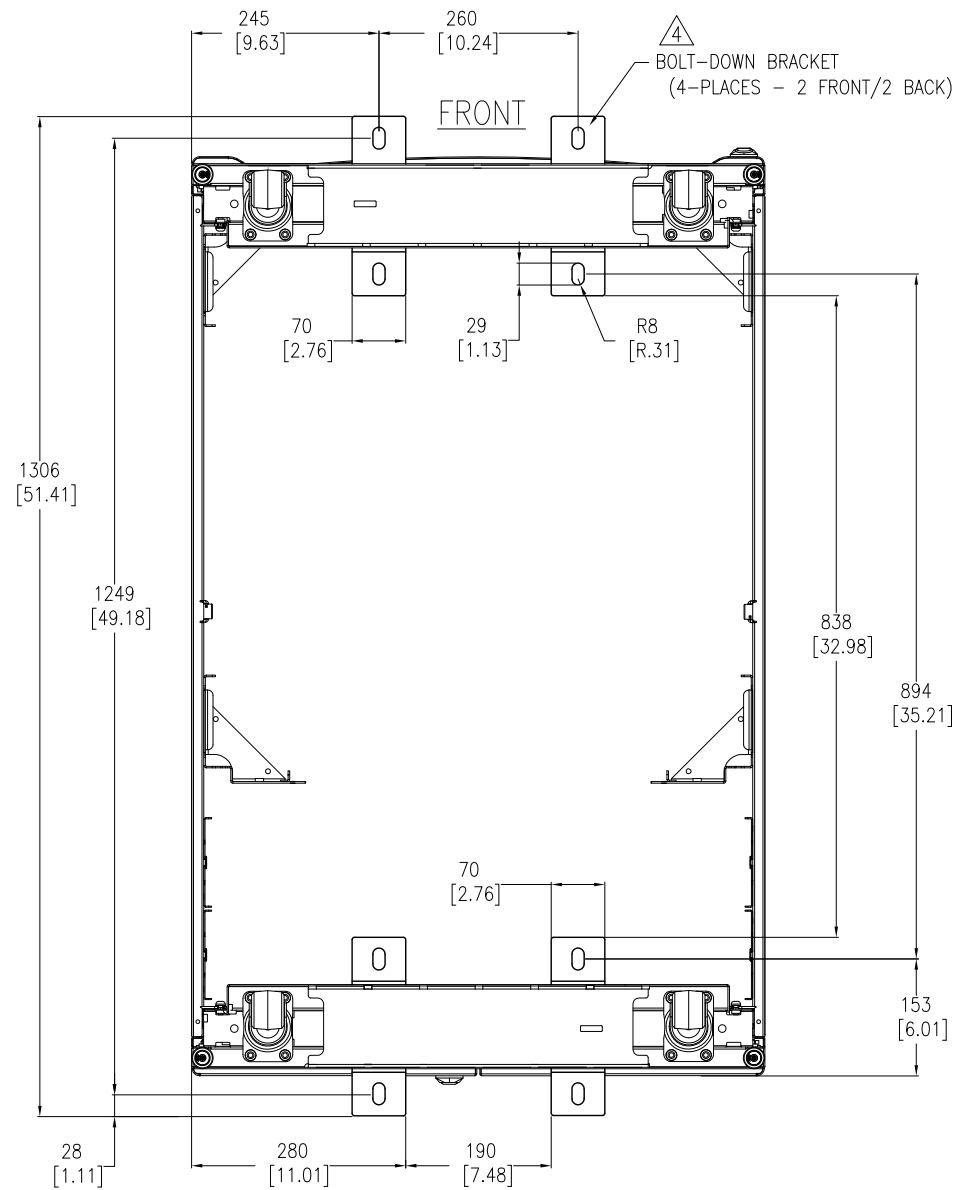

BOTTOM VIEW
(WITH OPTIONAL BOLT-DOWN BRACKETS FOR ANCHORING)
TOP ROOF NOT SHOWN

- NOTES:**
1. INSTALLATION SHALL COMPLY WITH ALL APPLICABLE NATIONAL, STATE AND LOCAL ELECTRICAL REGULATIONS.
 2. REFER TO PRODUCT DOCUMENTATION FOR ADDITIONAL DETAILS PRIOR TO INSTALLATION AND SITE PREPARATION WORK.
 3. ALL DIMENSIONS ARE IN MILLIMETERS [INCHES].
- △4. BOLT-DOWN KIT (SKU# AR7701) IS OPTIONAL AND HAS TO BE ORDERED SEPARATELY.

THIS DRAWING AND SPECIFICATIONS HEREIN ARE THE PROPERTY OF SCHNEIDER ELECTRIC AND SHALL NOT BE COPIED, REPRODUCED OR USED IN WHOLE OR IN PART, AS THE BASIS FOR THE MANUFACTURE OR SALE OF ITEMS WITHOUT WRITTEN PERMISSION FROM SCHNEIDER ELECTRIC. THIS DRAWING IS BASED UPON LATEST AVAILABLE INFORMATION AND IS SUBJECT TO CHANGE WITHOUT NOTICE.



TITLE: NetShelter SX 45U
750mm WIDE X 1200mm DEEP
ENCLOSURE WITH SIDES-SHOCK PACKAGING
BOTTOM VIEWS

PROJECT: SUBMITTAL DRAWINGS **SHEET:** 6 OF 6

DWG NO: AR3355SP **REV:** 0

DRAWN BY: JAYAPRAKASH **DATE:** 03-JULY-15 **ANGLE:** FIRST

ENGINEER: D HUDSON/ R PHILLIPS **DATE:** 06-JUL-15 **ANGLE:** ANGLE

APPROVED BY: GREG IVEY **DATE:** 06-JUL-15 **PROJECTION:** PROJECTION