



by Schneider Electric

User Manual Easy UPS On-Line SRVL Series Rack/Tower Convertible Extended Runtime 6000VA SRVLP6KRIL

Important Safety Instructions

SAVE THESE INSTRUCTIONS - This manual contains important instructions that should be followed during installation and maintenance of the UPS.



Read these instructions carefully and look at the equipment to become familiar with the device before trying to install, operate, service or maintain it. The following special messages may appear throughout this document or on the equipment to warn of potential hazards or to call attention to information that clarifies or simplifies a procedure.



The addition of this symbol either to a “Danger” or “Warning” safety label indicates that an electrical hazard exists which will result in personal injury if the instructions are not followed.



This is the safety alert symbol. It is used to alert you to potential personal injury hazards. Obey all safety messages that follow this symbol to avoid possible injury or death.

DANGER

DANGER indicates a hazardous situation which, if not avoided, **will result in** death or serious injury.

WARNING

WARNING indicates a hazardous situation which, if not avoided, **could result in** death or serious injury.

CAUTION

CAUTION indicates a hazardous situation which, if not avoided, **could result in** minor or moderate injury.

NOTICE

NOTICE is used to address practices not related to physical injury.

Product Handling Guidelines



<18 kg
<40 lb



18-32 kg
40-70 lb



32-55 kg
70-120 lb



>55 kg
>120 lb



For Professional Business Applications – Not For Consumer Use

Safety and General Information

Inspect the package contents upon receipt. Notify the carrier and dealer if there is any damages.

Read Safety Guide supplied with this unit before installing the UPS.

- This UPS is intended for indoor use only.
- Adhere to all national and local electrical codes.
- All wiring must be performed by a qualified electrician.
- Changes and modifications to this unit not expressly approved by APC by Schneider Electric could void the warranty.
- Do not operate this UPS in direct sunlight, in contact with fluids, or where there is excessive dust or high humidity.
- Do not operate the UPS near open windows or doors.
- Use only the mains and communication cables provided along with the UPS.
- The equipment is heavy. Always practice safe lifting techniques adequate for the weight of the equipment.
- Be sure the air vents on the UPS are not blocked. Allow adequate space for proper ventilation.

Note: Allow a minimum of 20 cm clearance on all four sides of the UPS.

- Additional safety information can be found in the Safety Guide supplied with this unit.
- The UPS input ground conductor must be properly bonded to protective earth at the service panel.
- If the UPS input power is supplied by a separately derived system, the ground conductor must be properly bonded at the supply transformer or motor generator set.

Electrical Safety

- When grounding cannot be verified, disconnect the equipment from the utility power terminal before installing or connecting to other equipment. Reconnect the power cable only after all connections are made.
- Connection to the branch circuit (mains) must be performed by a qualified electrician.
- The protective earth conductor for the UPS carries the leakage current from the load devices (computer equipment). An insulated ground conductor is to be installed as part of the branch circuit that supplies the UPS. The conductor must have the same size and insulation material as the grounded and ungrounded branch circuit supply conductors. The conductor will be green and with or without a yellow stripe.
- The grounding conductor is to be grounded to earth at the service equipment, or if supplied by a separately derived system, at the supply transformer or motor generator set.
- Leakage current for a pluggable, Type A UPS may exceed 3.5 mA when a separate ground terminal is used.
- For models with a hardwired input, the connection to the branch circuit (mains) must be performed by a qualified electrician.

Battery Safety

WARNING

RISK OF CHEMICAL HAZARD AND EXCESSIVE HEAT

- Replace the external battery packs at least every 10 years or at the end of its service life, whichever is earlier.
- Replace the external battery packs immediately when the UPS indicates battery replacement is necessary.
- Replace external battery packs with the same type of batteries as originally installed in the equipment.

Failure to follow these instructions can result in death or serious injury.

- Servicing of battery modules should be performed or supervised by personnel knowledgeable about batteries and required precautions. Keep unauthorized personnel away from batteries.
- APC by Schneider Electric uses Lithium-Ion batteries. Under normal use and handling, there is no contact with the internal components of the battery.
- Connect the power cable directly to a wall outlet. Do not use surge protectors or extension cords.
- The battery typically lasts for eight to ten years. Environmental factors impact battery life. Elevated ambient temperatures, poor quality utility power leading to frequent short duration discharges will shorten battery life.
- For longest battery performance, the ambient temperature should be maintained between 68 and 77 °F (20 and 25 °C).
- This equipment contains potentially hazardous voltages. Do not attempt to disassemble the unit. The unit contains no user serviceable parts. Repairs are must performed only by factory trained service personnel.
- Keep cells and batteries clean and dry.

- Discharge the charging source prior to connecting or disconnecting battery terminals.
- In the event of a cell leaking, do not allow the liquid to come in contact with the skin or eyes. If contact has been made, wash the affected area with copious amounts of water and seek medical advice.
- Do not drive nails into the battery pack.
- Do not strike the battery pack with a hammer.
- Do not stand on the battery pack.
- Do not short circuit battery pack.
- Do not place or use the battery pack near heat or fire.
- Do not use a dropped, damaged or deformed battery pack.
- Do not use the battery pack to power other equipment.
- CAUTION: Before installing or replacing the batteries, remove jewelry such as wristwatches and rings. High short circuit current through conductive materials could cause severe burns.
- CAUTION: Do not dispose of batteries in a fire. The batteries may explode.
- CAUTION: Do not open or tamper with the battery enclosure. Doing so will expose the cell terminals which poses an energy hazard.
- CAUTION: Do not open or mutilate batteries. Released material is harmful to the skin and eyes and may be toxic.
- CAUTION: Failed batteries can reach temperatures that exceed the burn thresholds for touchable surfaces.
- CAUTION: Turn off UPS before replacing battery.
- CAUTION: A battery can present a risk of electrical shock and high short-circuit current. The following precautions should be taken when working on batteries:
 - Disconnect the charging source prior to connecting or disconnecting battery terminals.
 - Do not wear any metal objects including watches and rings.
 - Do not lay tools or metal parts on top of batteries.
 - Use tools with insulated handles.
 - Wear rubber gloves and boots.
 - Determine if battery is either intentionally or inadvertently grounded. Contact with any part of a grounded battery can result in electric shock and burns by high short-circuit current. The risk of such hazards can be reduced if grounds are removed during installation and maintenance by a skilled person.

General Information

- Always recycle used batteries.
- Recycle the package materials or save them for reuse.
- Select a location sturdy enough for the combined weight of the unit.
- Operate the UPS within the specified environmental limits.
- Be sure to deliver the used battery to a recycling facility or ship it to Schneider Electric in the replacement battery packing material.

Radio Frequency Warning

This is a category C3 UPS product. In a residential environment, this product may cause radio interference, in which case the user may be required to take additional measures to correct the interference.

Product Description

The APC™ by Schneider Electric Easy UPS is a high performance, uninterruptible power supply (UPS). The UPS helps to protect the connected electronic equipment from utility power blackouts, brownouts, sags, and surges and small utility fluctuations and large disturbances. The UPS also provides battery backup power to the connected equipment until utility power returns to specified levels or the batteries are fully discharged.

This user manual is available in the package and on the APC by Schneider Electric website, www.apc.com.









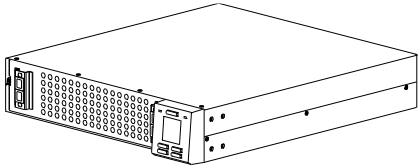
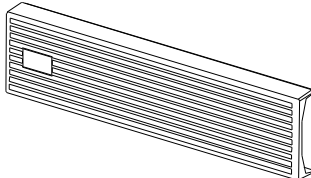
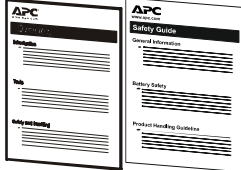

Package Contents

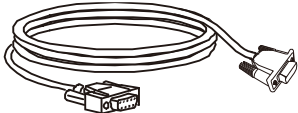
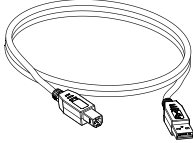
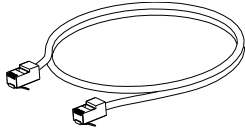
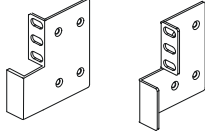
Read the Safety Guide before installing the UPS.

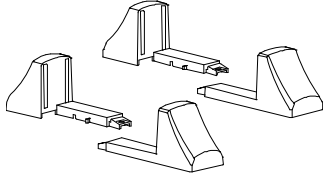
Inspect the UPS upon receipt. Notify the carrier and dealer if there is damage.

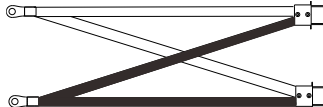
The packaging is recyclable; save it for reuse or dispose of it properly.

Note: The model and serial numbers in a small label located on product label.

<p>Easy UPS</p> 	<p>Front bezel</p> 	
<p>User manual & Safety guide</p> 	<p>PowerChute management software</p> 	
<p>RS232 cable</p> 	<p>USB cable</p> 	<p>RJ45 cable</p> 
<p>Rack-mount brackets</p>  <p>Flat head screws x 8</p> 	<p>Stabilizer brackets</p>  <p>Pan head screws x 4</p> 	
<p>Battery cable (600mm)</p> 	<p>90° ring terminal x 8</p> 	
<p>M20 Strain relief x 2</p> 	<p>M25 Strain relief x 2</p> 	

Optional Accessories

For optional accessories, refer to the APC by Schneider Electric Website at www.apc.com.

Specifications

Environment Specifications

NOTICE

RISK OF EQUIPMENT DAMAGE

- UPS must be used indoors only.
- The installation location should be sturdy to withstand the weight of the UPS.
- Do not operate UPS where there is excessive dust or where the temperature or humidity are outside specified limits.

Failure to follow these instructions can result in equipment damage.

Applicable power grid power distribution system	TN Power System
Applicable standards	IEC 62040-1
Overvoltage category	II

Environment Specifications

Temperature	Operating	0 to 40 °C at rated load. 40 to 50 °C derated to 75% of maximum load capacity.
	Storage	-20 to 50 °C
Elevation	Operating	0 - 1,000 m: normal operation 1,000 m – 3,000 m: The load capacity reduces @1% for every 100 m increase in elevation. > 3,000 m: UPS will not work
	Storage	0 - 15,000 m
Humidity		0 to 95% relative humidity, non-condensing
International Protection Code		IP20
Pollution Degree		2

Physical Specifications

	SRVLPM6KRIL
Dimensions with Package Height x Width x Depth	240 x 600 x 800 mm (9.45 x 28.03 x 31.50 in)
Dimensions without Package Height x Width x Depth	86 x 438 x 695mm (3.39 x 17.24 x 27.36 in) *D1=660mm, D2=795mm
Weight with Package	21.7 kgs (47.84 lbs)
Weight without Package	19.7 kgs (43.43 lbs)

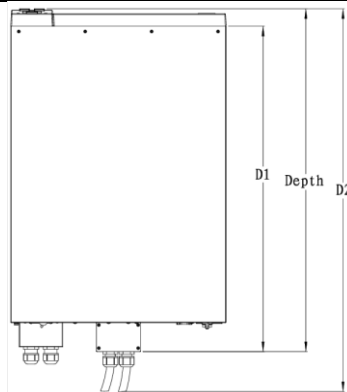

Input Specifications

	SRVLP6KRIL
Nominal Input Voltage	230 VAC
Input Frequency	50±4 Hz or 60 ± 4 Hz
Input Voltage Range (100% load)	186 VAC – 300 VAC
Input Voltage Range (60% Load)	120 VAC – 300 VAC
Input Power Factor (100% Resistive Load)	≥ 0.99
Input Connection	Terminal Block
Input Protection	Input circuit breaker (50A, 240VAC)

Output Specifications

	SRVLP6KRIL
Capacity	6000 VA / 6000W
Topology	Double conversion online
Power Factor	1.0
Nominal Output Voltage	230 VAC
Other Programmable Voltage	220 VAC, 240 VAC
Efficiency at Rated Load in Online Mode*	93.5% MAX
Efficiency at Rated Load in ECO Mode*	97% MAX
Output Voltage Regulation	± 1% static
Overload – Online Mode	100% < Nominal Load ≤ 110%: Alarm, transfer to bypass after 10 min 110% < Nominal Load ≤ 130%: Alarm, transfer to bypass after 1 min 130% < Nominal Load: Alarm, transfer to bypass mode after 1sec
Overload – Battery Mode	100% < Nominal Load ≤ 110%: Alarm and shut down after 30 sec 110% < Nominal Load ≤ 130%: Alarm and shut down after 10 sec 130% < Nominal Load: Fault and shut down immediately
Charger Voltage	52.5 V
Charge Current**	20 A
Typical Recharge Time, Recover to 90% (x1 SRVL48RMBP3U)	5 hrs
Output Voltage Distortion – Online Mode & Battery Mode	<ul style="list-style-type: none"> • 1% max. for full linear load, • 4% max. for full RCD load (100% VA, 0.8PF)
Frequency – Online Mode	50 ± 4 Hz or 60 ± 4 Hz
Frequency – Battery Mode	50 ± 0.1 Hz or 60 ± 0.1Hz
Crest Factor	3:1
Transfer Time (Online Mode ↔ Battery Mode)	0 ms
Waveform	Pure sine wave
Output Connection	Terminal Block
Surge Energy Rating	600J
Output Short-Circuit Current	50A(RMS), 200A(PEAK)
Electrical Output Supply System	TN
Noise Level***	< 57.5dBA @ 1 Meter
Bypass	Internal bypass
Runtime 100% Load (x1 SRVL48RMBP3U)****	34 min
Runtime 50% Load (x1 SRVL48RMBP3U)****	68 min
Communication Port	USB port, RS232 serial port, Intelligent card slot
Management	Windows family and Linux

*Efficiency is the maximum.

**If load >100%, charging current will be derated to 5A.

***100% load with battery fully charged at 25 °C.

****Runtime only as reference data at temperature of 25 °C. As batteries age, runtime performance will naturally degrade.

Battery Support

Battery Pack Model	SRVL48RMBP3U
Configuration	External battery
Type	Lithium Ion
Typical Capacity	4800 Wh
Nominal Voltage	48 V
Recommended Charge Voltage	52.5 V
Maximum Battery Pack Support	3
Communication Port	RS485 (RJ45) for connecting Easy UPS and Battery Pack CAN bus (RJ11) for connecting multiple Battery Packs

Rear Panel Features

SRVLP6KRIL

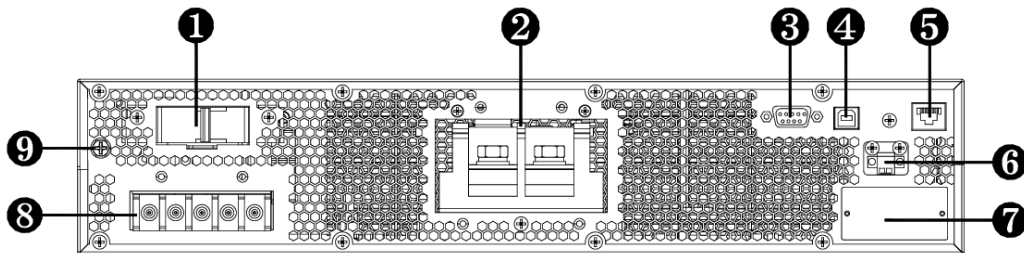

1	Input circuit breaker	6	EPO port (Emergency power off connector)
2	Battery terminal block	7	Intelligent card slot
3	RS232 serial port	8	Terminal block (Output terminals – Input grounding terminal – Input terminals)
4	USB port		
5	RS485 COM port (RJ45)	9	Ground screw

Actual UPS may differ in appearance from illustration.

Basic Connectors



USB

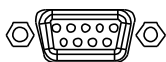

Serial port

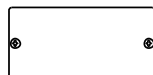









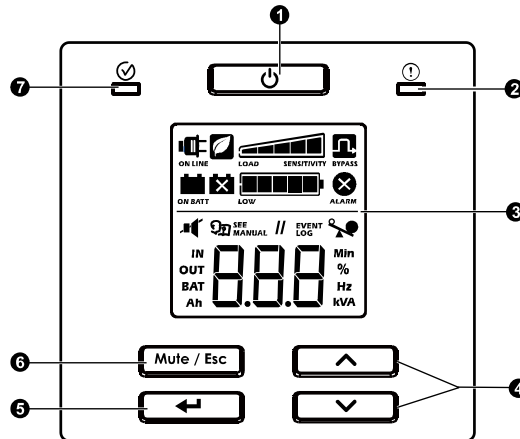

Intelligent card slot

Power management software and interface kits can be used with the UPS.
Use only interface kits supplied or approved by Schneider Electric.











Front Panel Display Features

These Easy UPS models are equipped with an intuitive and configurable LCD display. This display complements the software interface as both convey similar information and either may be used to configure the Easy UPS settings.



<p>❶</p>	<p>POWER ON/OFF button</p> 	<ul style="list-style-type: none"> ● Press this button to turn on the UPS. ● Press and hold this button until a beep is heard to turn off the UPS. ● Press this button to reset alarms.
<p>❷</p>	<p>Alarm LED</p> 	<p>This Alarm LED illuminates red when the UPS detects an internal error and blinks red for UPS notifications. See “Alarms and System Events” on page 21 in this manual.</p>
<p>❸</p>	<p>LCD Display</p>	<p>The display interface options are visible on this LCD screen. Press the  or  button to activate LCD, if the display is not illuminated.</p>
<p>❹</p>	<p>UP / DOWN button</p>  	<p>Press these two buttons to scroll through the main menu options and display screens.</p>
<p>❺</p>	<p>ENTER button</p> 	<p>Press this button to enter the menu or to select a menu item/ value during navigation.</p>
<p>❻</p>	<p>MUTE/ESC button</p> 	<ul style="list-style-type: none"> ● To acknowledge audible alarms and mute them temporarily. If alarm is not mute, check “Audible Alarm” on page 21 for the details in this manual. ● To exit a sub menu and return to the main menu.
<p>❼</p>	<p>Status LED</p> 	<p>The Status LED illuminates green when the power is on. This LED indicates two different states of output power:</p> <ul style="list-style-type: none"> ● Output off: LED blinks. Press POWER ON/OFF button to turn the output power on. ● Output on: LED illuminates green continuously.

LCD display icons

 ON LINE	<p>On Line: The UPS is drawing utility power and performing double conversion to supply power to the connected equipment.</p>
 ON BATT	<p>On Battery: The UPS is supplying battery backup power to the connected equipment. Note: This icon will flash when the communication between the external battery pack and the UPS is being established and will not be illuminated once the communication is established.</p>
 	<p>Replace Battery: The battery is not connected securely or the battery is nearing the end of its service life and should be replaced.</p>
 BYPASS	<p>Bypass: The UPS is in bypass mode, and the connected equipment receives the utility power directly. Bypass mode operation is the result of an internal UPS event or an overload condition. Battery operation is not available while the UPS is in bypass mode. See “Alarms and System Events” on page 21 in this manual.</p>
 	<p>Green Mode: This icon in combination with Bypass icon, indicates that the UPS is working in Green mode. The connected equipment will receive the utility power directly as long as the input voltage and frequency are within the configured limits.</p>
 ALARM	<p>System Alarms: An internal error is detected. See “Alarms and System Events” on page 21 in this manual.</p>
 	<p>Overload: The equipment connected to the UPS is drawing more power than rated. Note: This icon will flash when the communication between the external battery pack and the UPS is being established and will not be illuminated once the communication is established.</p>
 	<p>Battery Charge: The battery charge level is indicated by the number of bar sections illuminated. When all five blocks are illuminated, the battery is fully charged. Each bar represents approximately 20% of the battery charge capacity. The icon LOW will be displayed only when the battery is discharged to low battery state in battery mode.</p>
 	<p>Load Level: The load percentage is indicated by the number of load bar sections illuminated. Each bar represents approximately 20% of the maximum load capacity.</p>
 	<p>Mute: An illuminated line through the icon indicates that the audible alarm is disabled.</p>
 SEE MANUAL	<p>Alarm or notification: The UPS has detected an internal error or the UPS is in configuration mode. See “Alarms and System Events” on page 21 in this manual.</p>
EVENT LOG	<p>Event: The icon is illuminated when the user is viewing the event log.</p>

Tower Installation

⚠ CAUTION

RISK OF FALLING EQUIPMENT

- The Easy UPS is heavy.
- Always practice safe lifting techniques adequate for the weight of the equipment.
- Do not lift the Easy UPS by holding the front panel display.
- Be sure that the stabilizer brackets are installed along with the Easy UPS in tower orientation.

Failure to follow these instructions could result in equipment damage and minor or moderate injury.

Front panel display rotation

①

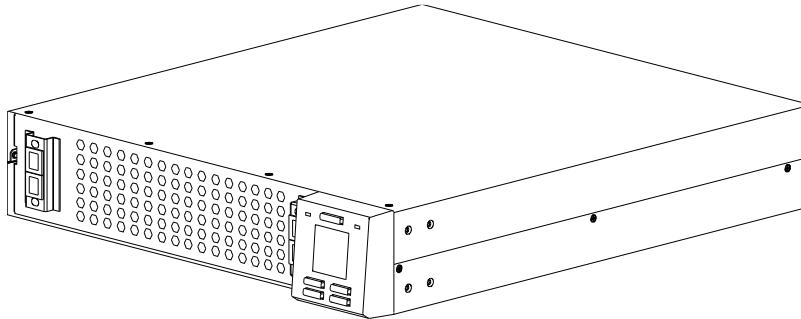

② Pull out the LCD display on the UPS.

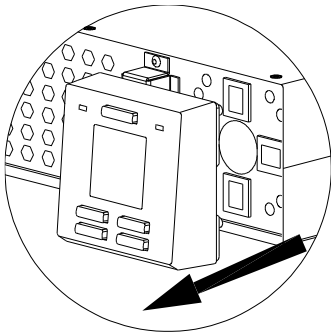

③ Rotate 90 degrees to the right.

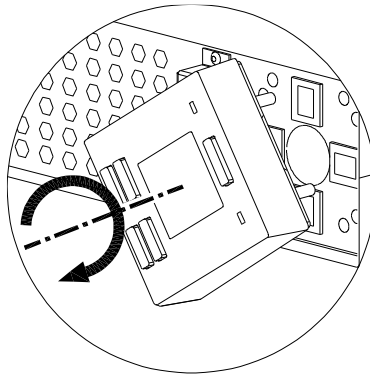

④ Plug back in the LCD display on the UPS.

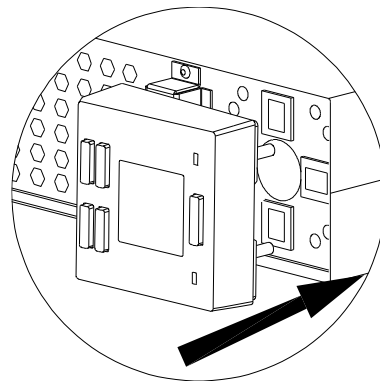

⑤

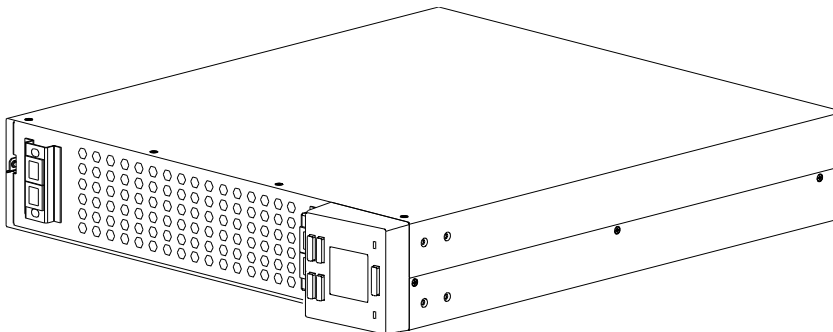

Installing stabilizer brackets

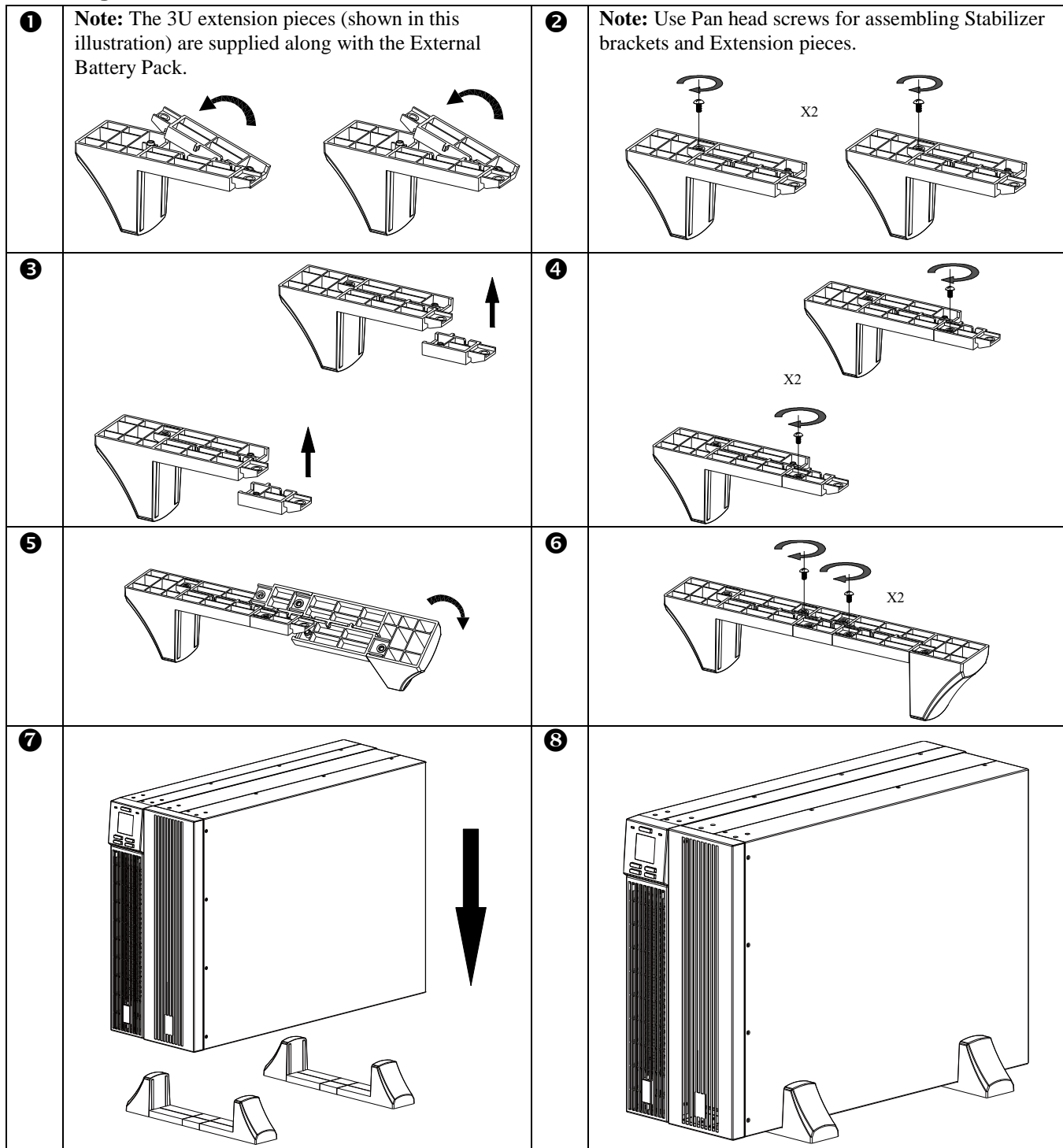

NOTE: Maintain approximately 70 mm distance from the edge of the unit, when installing the stabilizer brackets to the Easy UPS.

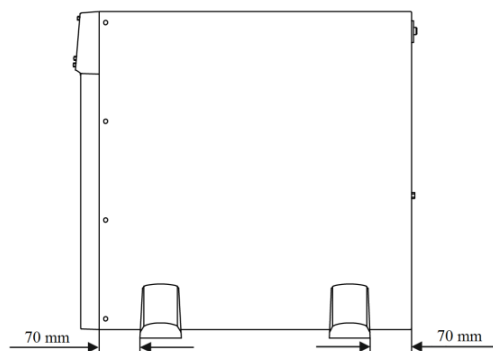

Rack-Mount Installation

⚠ CAUTION

RISK OF FALLING EQUIPMENT

- The equipment is heavy.
- Always practice safe lifting techniques adequate for the weight of the equipment.
- Always use the recommended number of screws to secure brackets to the UPS.
- Always use the recommended number of screws to secure the UPS to the rack.
- Always install the UPS at the bottom of the rack.
- Always install the External Battery Pack below the UPS in the rack.

Failure to follow these instructions could result in equipment damage and minor or moderate injury.

- Before installing the battery pack into the 19 inch rack enclosure, be sure that the rack is already equipped with a shelf.
- Be sure that the installed shelf can withstand the weight of the UPS and/or battery pack. Otherwise, install an optional rail kit accessory (SRVRK1 for UPS, SRVRK2 for SRVL48RMBP3U) which can be purchased separately.

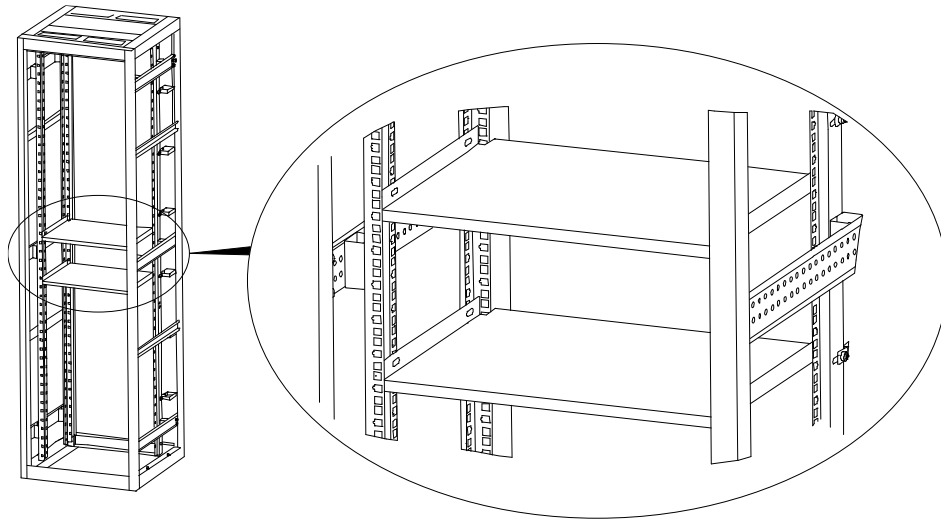

Follow the instructions below to secure and position battery pack into the 19 inch rack enclosure.

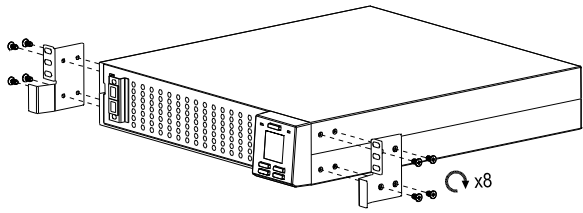
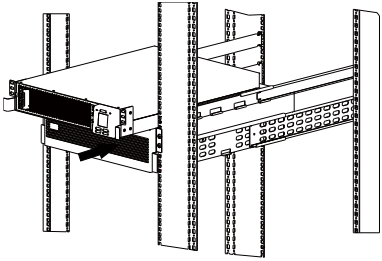
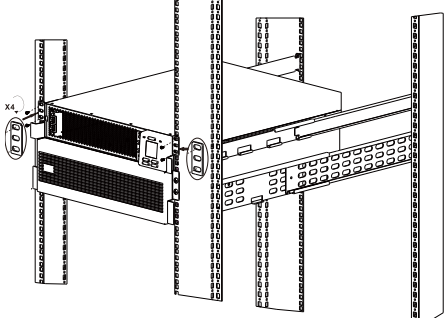
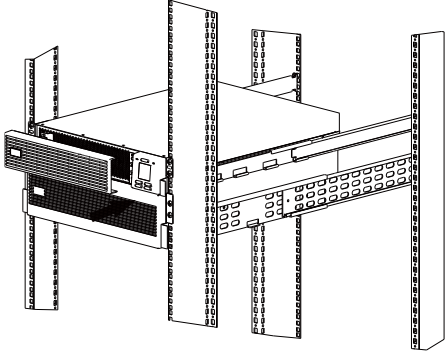
<p>1 Install the rack-mount brackets with Flat head screws.</p> 	<p>2 Lift the Easy UPS module and slide into rack enclosure.</p> 
<p>3 Secure the Easy UPS module to the rack with screws, nuts and washers (not supplied in the package).</p> 	<p>4 Install the front bezel.</p> 

Hardwiring

Hardwiring must be performed by a qualified electrician. Adhere to all national and local electrical codes.

Input/Output Hardwiring

NOTICE

RISK OF DAMAGE

- Do not use this UPS for Two phase (Line to Line) input configuration.
- The UPS needs a neutral connection to work properly. Operation without Neutral may damage the unit or connected load.

Failure to follow these instructions can result in equipment damage.

Install a high magnetic 50 Amp utility circuit breaker.

Use 6mm² (or #10 AWG) 105°C type wires.

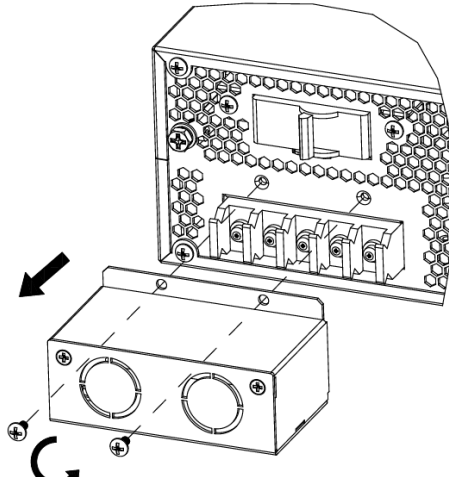
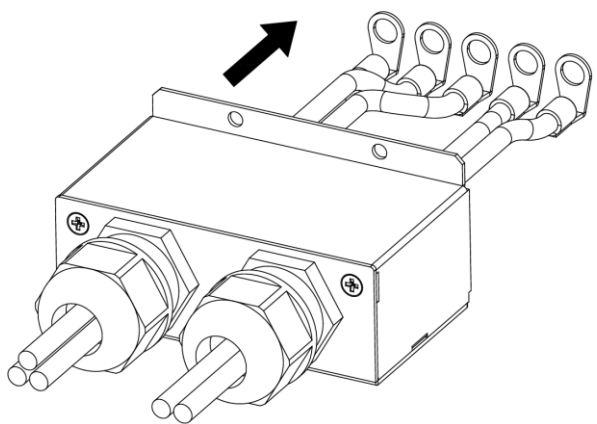
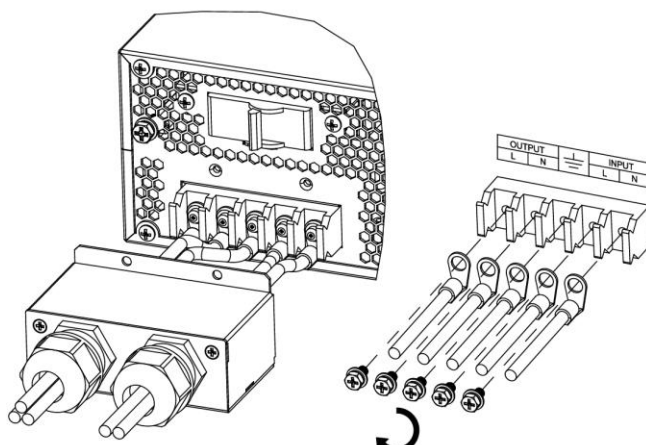
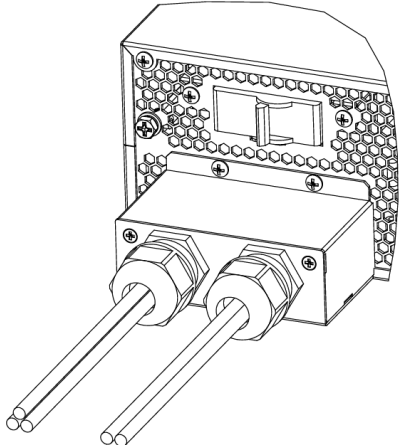
<p>1 Remove terminal cover with two screws.</p> 	<p>2 Install wires to 90° ring terminals.</p> 
<p>3 Fix assembled ring terminals to input/output terminals on the UPS with screws as shown below chart. Recommended torque: 10kgf.cm</p> 	<p>4 Install the input/output terminal cover to the original position with two screws.</p> 

Connect Battery Pack to Easy UPS

⚠ CAUTION

RISK OF ELECTRIC SHOCK

- All electrical work must be performed by a qualified electrician.
- Be sure that the ground wire is securely connected.
- Do not short the battery terminals.
- Do not wear jewelry when working with electrical equipment.

Failure to follow these instructions can result in moderate injury.

Connect battery pack (SRVL48RMBP3U) to the UPS

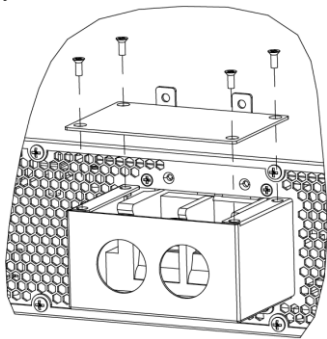
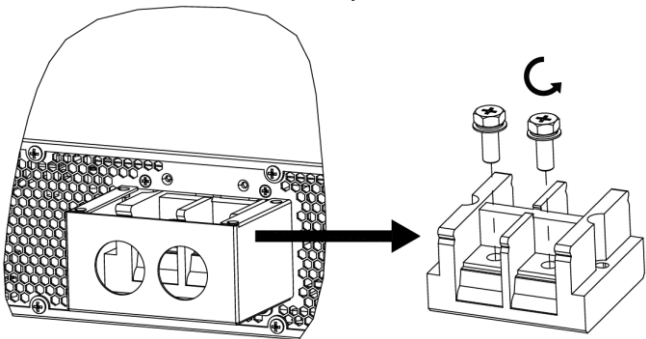
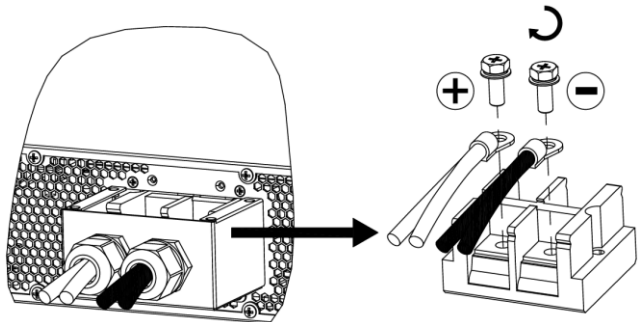
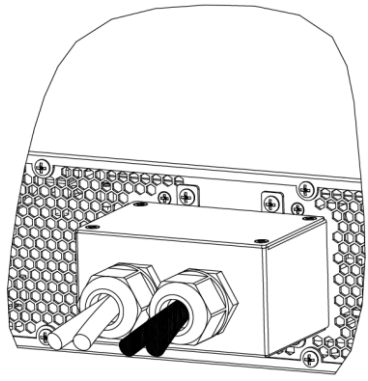
<p>❶ Remove battery terminal cover on the UPS with 6 screws.</p> 	<p>❷ Remove screws from the battery terminal of the UPS.</p> 
<p>❸ Connect battery cable (supplied in the UPS package) to the battery connector of the UPS. Red cable to positive terminal (+). Black cable to negative terminal (-). Make sure the screws are tightened with torque of 16 kgf.cm.</p> 	<p>❹ Install the battery terminal cover to the original position.</p> 

- 5** a. Connect Easy UPS to Battery Pack (SRVL48RMBP3U) using the battery cable supplied with the UPS. Use the supplied screws to secure the battery connector clamp to the battery pack.
 b. Connect the ground wire supplied with the Battery Pack, be sure that the ground screw is tightened fully (tightening torque: 12 kgf.cm).

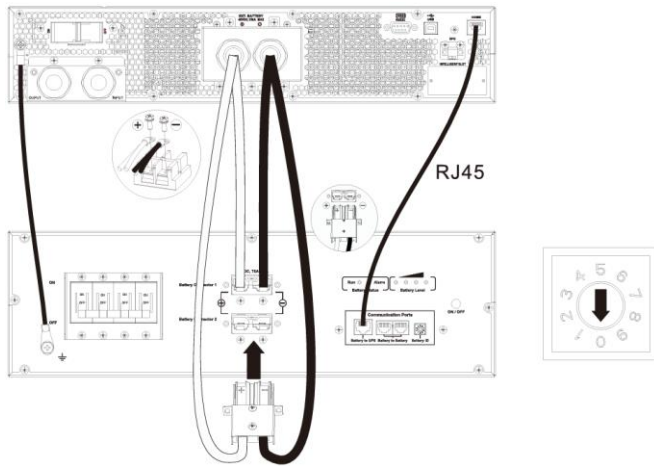

- 6** a. Connect one end of the COM cable (RJ45 cable supplied with the UPS) to the BMS COM port on the battery pack.
 b. Connect the other end of the COM cable to the BMS COM port on the UPS.
 c. Set the ID switch to "0".

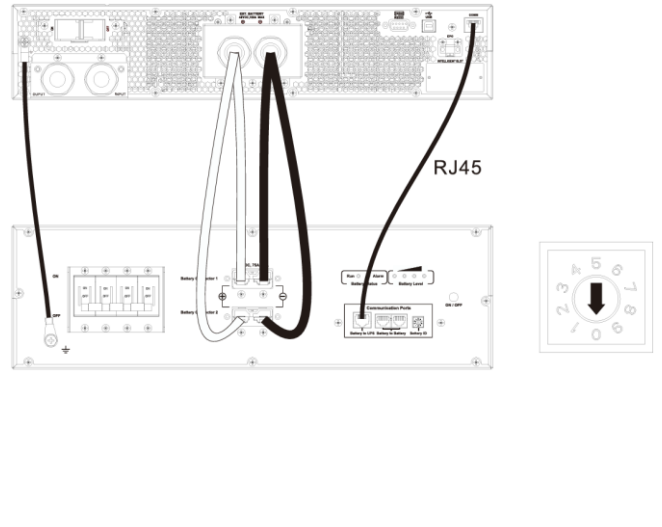

- 7** Switch on the breaker

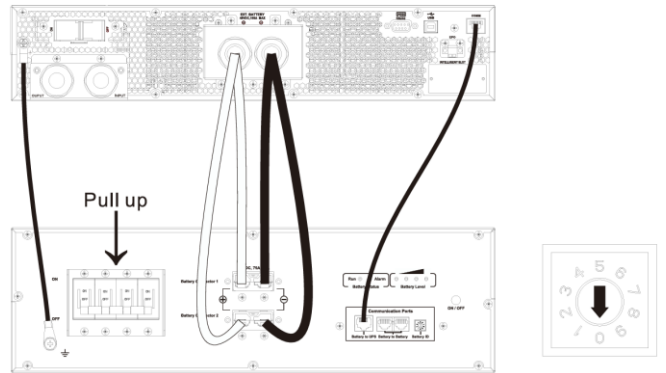

NOTE 1 : SRVL48RMBP3U can only be used with SRVL series, 6000VA Easy UPS.

NOTE 2 : If the UPS will not be used for a period of time, shut down and turn off the breaker in the external battery pack.

NOTE 3: When replacing the battery pack, please turn off the UPS and switch off battery breaker.

Connect Multiple Battery Packs

To extend the runtime, connect additional battery packs.

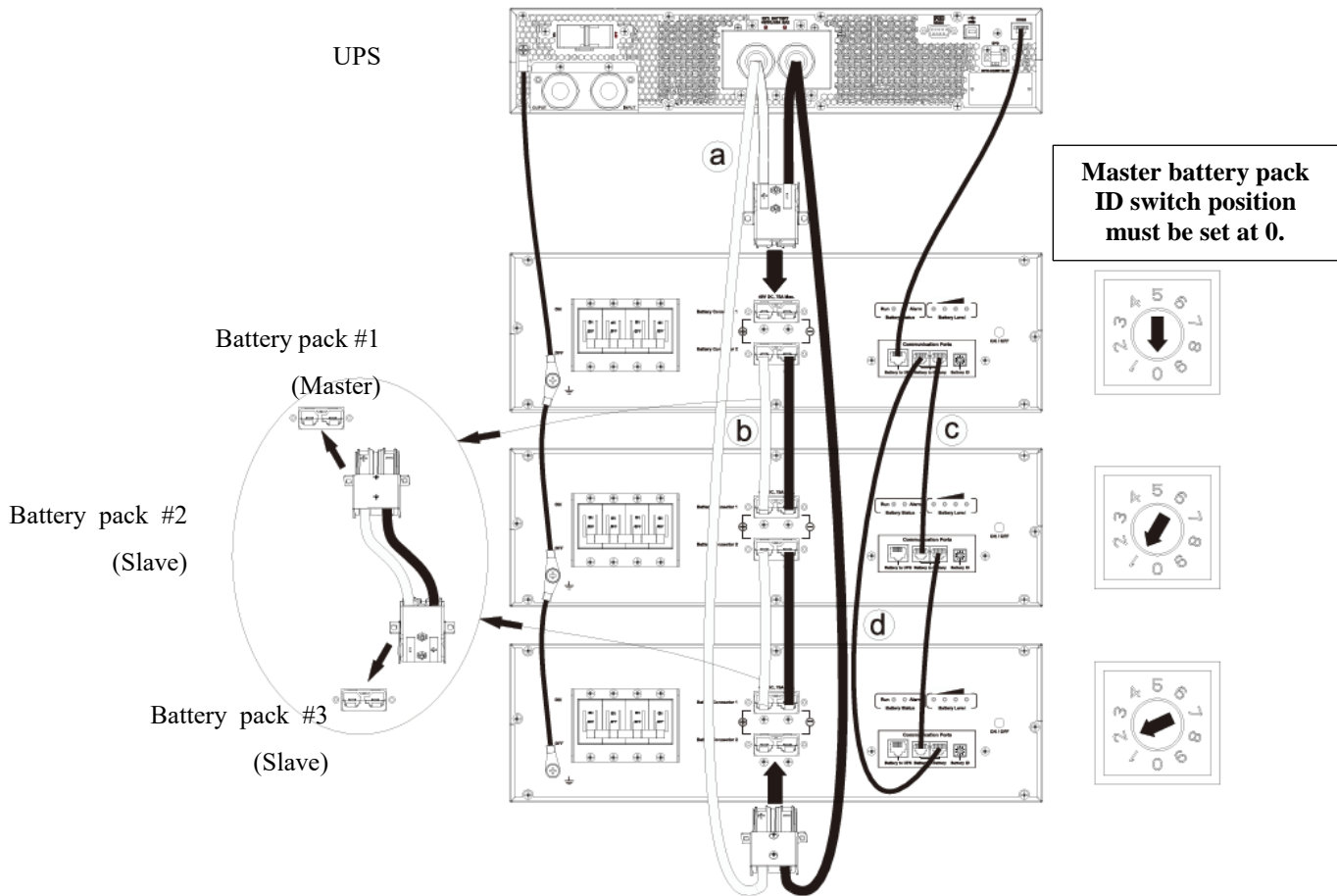

1. Connect one end of battery cable **a** to the battery connector terminals on the UPS and the other end to the CON 1 receptacle on the battery pack. Be sure to connect the ground wire securely.
2. Connect one end of the COM cable (RJ45 cable supplied with the UPS) to the COM port **1** of Battery pack #1. Connect the other end to BMS communication port on the UPS. Battery pack #1 is also called “master” and directly communicates with the UPS. The remaining battery packs are called “slave” and communicate with the UPS through Battery pack #1.
3. Connect one end of battery cable **b** to CON 2 receptacle on Battery pack #1 and the other end to CON 1 receptacle on Battery pack #2. Be sure to connect the ground wire securely.
4. Connect one end of the RJ11 cable **c** (supplied with the battery pack) to the Battery capacity extension port in Battery pack #1 and the other end to Battery capacity extension port in Battery pack #2.
5. Repeat steps 3 and 4 for connecting Battery pack #2 and Battery pack #3.
6. Connect one end of RJ11 cable **d** (supplied with the battery pack) to the Battery capacity extension port in Battery pack #3 (last battery pack connected) and the other end to the Battery capacity extension port in Battery pack #1.
7. Set up the ID code for battery packs by rotating the disc on the ID switch. The ID switch in master battery pack must be set to “0”. Use random numbers from 1 to 9 for setting up the ID of the slave battery packs. Assign an unique ID to each battery pack for paralleling the battery packs.

NOTE 1: Maximum 3 external battery packs can be connected to the UPS based on the Easy UPS charging capability.

NOTE 2: **a** is battery cables supplied in the UPS package.

b is battery cable, **c** and **d** are RJ11 cable are supplied with the battery packs.

NOTE 3: When a new battery pack is connected in parallel to the master battery pack, the new battery pack will automatically get paralleled when the State of Charge (SOC) of both the master battery pack and the new battery pack is 100%. Until the SOC of both the battery packs reach 100%, the new battery pack will only get charged and will not share the load if the UPS goes into on-battery mode during this period.

Start up

⚠ CAUTION

RISK OF ELECTRIC SHOCK

- Adhere to all national and local electrical codes.
- All electrical work must be performed by a qualified electrician.
- Turn off all power to this equipment before working on the equipment.
- Switch the external circuit breaker off. Practice lockout/tagout procedures.
- Select wire size and connectors according to national and local codes.
- Do not wear jewelry when working with electrical equipment.

Failure to follow these instructions can result in minor or moderate injury.

Connect power and equipment to the UPS

1. Connect equipment to the Easy UPS. Do not use extension cords.
2. Connect input utility power to the Easy UPS.
3. Switch on the input utility power. The Easy UPS display panel will illuminate when utility power is available.

Start the UPS

Press ON/OFF button for one second. Release the button when a beep is heard. The UPS will start up.

- The battery charges to 90% capacity during the first five hours of normal operation.
- **Do not** expect full battery runtime during this initial charge period.

Cold start the UPS

Use cold start feature to supply power to connected equipment from the UPS batteries.

Press ON/OFF button. The display panel will illuminate. Press ON/OFF button again to supply battery power to the connected equipment.

Turn off the UPS

Press ON/OFF button for one second. Release the button when a beep is heard. The UPS will power off and LCD display will be turned off in 2 minutes. Make sure that the LCD display is not illuminated before restarting the UPS.

Connect and install PowerChute™ UPS Management software

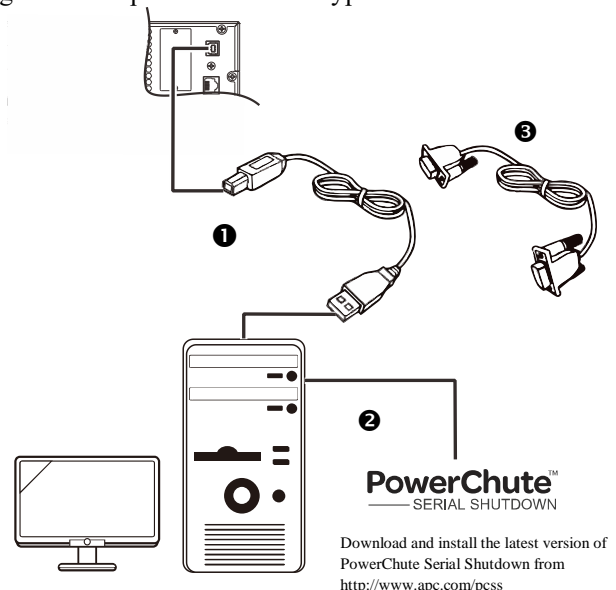

Easy UPS On-Line is provided with PowerChute™ UPS Management Software for unattended operating system shutdown, UPS monitoring, UPS control and energy reporting. The following diagram is a representation of a typical server installation.

1. Connect the USB cable from the rear of the UPS to the protected device such as a server.
Note: A USB driver is required to communicate with PowerChute over USB. For more information, refer to Knowledge Base article FA000223363 on the APC website (<https://www.apc.com/us/en/faqs/home>).
2. For a server or other device with an operating system, download and install latest version of the PowerChute Serial Shutdown from <https://www.apc.com/pcss>. PowerChute Serial Shutdown supports graceful shutdown in the event of an extended power outage.
Note: PowerChute is a 64-bit only application and cannot be installed on a 32-bit operating system.
3. A built-in serial port is also available for additional communication options with serial cable.
Note: RS232 and USB cannot be used at the same time



Operation















UPS Display Parameters

Navigate using the  or  button of display, so you can see data show on LCD display given in the table.

Parameter	Units	Indicator Icons
Output voltage	VAC	OUT, V
Output frequency	Hz	OUT, Hz
Input voltage	VAC	IN, V
Input frequency	Hz	IN, Hz
Remaining on battery runtime	Minutes	BAT, Min
Battery voltage	VDC	BAT, V
Battery Current	A	BAT, A
State of battery charge	%	BAT, %
Total Ah capacity of connected battery	Ah	BAT, Ah
SOH(state of battery health)	%	BAT, Ah, %
Ambient temperature	° C	NUMBER, C
Load level in percentage (maximum of Watts or VA)	%	OUT, %
Load level in kVA	kVA	OUT, kVA

Configure UPS parameters

Follow the steps to configure parameters in the UPS:



1. Press the  button. Press the  or  button to navigate to “Set”.
2. Press the  button. Navigate through the parameters using the  or  button.
3. Press the  button to edit a parameter. Icons start flashing to indicate the editing.
Press the  or  button to navigate between the options available for the selected parameter.
4. Press the  button to select the option or  button to abort the editing of current parameter. Flashing of icons stops after this. Press the  or  button to navigate between parameters.
5. Press the  button to exit menu navigation.















UPS settings

Configure UPS settings using the display interface. See “Configure UPS parameters” section to edit the parameters.

Function	Factory Default	User Selectable Options	Description
Output voltage	230 Vac	220, 230, 240 Vac	Allows the user to select output voltage while the UPS is operating in no output mode or bypass mode.
Audible alarm	Enable	Enable, disable	When an audible alarm occurs, select disable to mute the audible alarm. Then, enable the audible alarm again after detected fault/problem is solved to restart audible alarm notification.
Green mode/ high efficiency mode	Disabled	Enable/Disable	<p>When this mode is enabled, connected equipment receives utility input power through the bypass relay as long as input voltage is within the range of $\pm 5\%$ of configured output voltage and ± 4 Hz of configured output frequency. Inverter is turned off during this mode.</p> <p>If utility power input goes out of range, inverter is turned on. The load is transferred to online mode or battery mode. The power to the connected equipment may be interrupted up to 10 milliseconds.</p>
Charge current setting	20 A	10 A, 20 A, 30 A	Set the charging current.
EOL alert setting	Unblock	CLO (Block)/NUL (Unblock)	The UPS will block EOL alert for one week when it is set to “Block”. If the battery is still not replaced in one week, the UPS will provide the alert again.
Battery pack quantity setting	Auto	AUT (auto), 1, 2, 3	When UPS connect with multiple battery packs, please ensure 1, 2 or 3 setting matches the real connected pack quantity.

Advance display navigation

There are five options in main menu and two sub-menu options in UPS display. Press the  button from the Home Screen to access these menu options. Use the  or  button to navigate between the menu options.

Menu Option	Description
LOG	<p>Show Event Log</p> <p>Use this menu option to see the UPS event log. The UPS records the last 10 events and displays the codes in this log.</p> <p>Press the  button to see the log. Use the  or  button to see the logged events. The  button navigates towards old events and the  button navigates to new events.</p> <p>Every log entry has a numeric and textual event code. At the end of the log, the word “End” will be displayed. Press the  button to return to the Home Screen.</p>
SET	<p>Configure the UPS</p> <p>Use this menu option to configure the UPS parameters.</p> <p>Press the  button to see the configuration options. See “Configure UPS parameters” on page 18 for details. Press the  button to return to the Home Screen.</p>
UPS	<p>Show UPS information</p> <p>Use this menu option to see the UPS information.</p> <p>Press the  button to see the rating of the UPS. Press the  button to see the UPS firmware version. Press the  button to return to the Home Screen.</p>
bYP	<p>User Command to bypass</p> <p>Use this menu option to switch the UPS to bypass mode or bring the UPS to online mode from bypass mode.</p> <p>Press  button:</p> <p>Put Put: Use to switch the UPS to bypass mode of operation.</p> <p>Out Note: Power to the connected equipment will drop, if the mains voltage is not within the threshold limits.</p> <p> Out: Bring the UPS out of bypass and restore clean power to the connected equipment.</p>
tSt	<p>Execute Battery Self-Test</p> <p>Use this menu option to conduct a self-test and determine the battery status.</p> <p>Press the  button to initiate the test. If the test command is accepted, the UPS will initiate a self-test and will start a count down on the display.</p> <p>Display messages are shown at the end of the test.</p> <p>rFd Test refused. The output is off or battery is not charged.</p> <p>FId Test not passed</p> <p>PA5 Test passed</p> <p>Press the  button to return to the Home Screen</p>

Alarms and System Events

Audible Alarm

Beeper continuously on	Event Alarm - UPS has detected an event. See “Alarms and System Events” in this manual.
Continuous beeps, every half second	Low Battery State - The battery is nearing its complete discharge state. The UPS is about to shut down.
	Overload condition - The equipment connected to the UPS is drawing more power than the UPS capacity.
4 beeps every 30 sec	On Battery State - The UPS is supplying battery backup power to the connected equipment.
Short beep every 2 min	On Bypass State – The connected equipment is receiving utility power directly.

Display code	Description	Solution
bdc	Battery is not connected.	<ol style="list-style-type: none"> 1. Be sure that battery cable is properly secured at both the UPS and the battery pack. 2. Be sure that the first battery pack (master battery pack) ID switch is set to 0 and all IDs should be set differently.
LOS	Communication error.	<ol style="list-style-type: none"> 1. Be sure that the communication wire (RJ45) between the UPS and the first battery pack is properly secured. 2. Be sure that the communication wires (RJ11) between the battery packs are properly secured. 3. Be sure that the ID setting of master battery pack is “0” and each parallel battery pack is unique. 4. Be sure that the battery pack quantity setting is matching the real connected pack quantity.
SC	UPS has experienced a short circuit at the output. Unit will try to auto-recover from this condition.	Check if there is any short circuit at the UPS output. Remove the short circuit and wait for the unit auto-recover or press  button to start the UPS.
OL	UPS is experiencing an overload condition.	Disconnect non-essential equipment from the UPS to eliminate the overload condition.
dch	The UPS has detected a DC voltage error. Unit will try to auto-recover from this condition.	If the UPS does not recover automatically, contact APC by Schneider Electric customer support.
Hot	Temperature of the unit is rising above the set limits.	<ol style="list-style-type: none"> 1. Disconnect non-essential equipment from the UPS to reduce the UPS load. 2. Be sure that ambient temperature is within limits. Be sure that adequate clearance around the UPS is maintained. <p>After completing the above two items, the UPS needs to cool to the normal operating temperature, and then restart the UPS.</p>
0t	Temperature of the unit is rising above the warning value.	<p>Disconnect non-essential equipment from the UPS to reduce the UPS load.</p> <p>Be sure that ambient temperature is within limits. Be sure that adequate clearance around the UPS is maintained.</p>

Display code	Description	Solution
CH9	UPS has detected a charger error.	Be sure that there is no short circuit at the UPS battery terminals. Press  button to start the UPS.
EOL	The battery is nearing its complete life.	When SOH is less than 65%, UPS will alert with “EOL”. When SOH is less than 60%, the battery pack will enter no charging status. Replace the battery pack.
bot	The internal temperature of the battery is too high.	BMS in battery pack will automatically stop battery discharging.
EPO	EPO alert	Be sure that the EPO terminal is connected securely.
dCF	A overcharge current, discharge current or over-temperature of DC heatsink is detected. The UPS will try to auto-recover from this condition.	If the UPS does not recover automatically, contact APC by Schneider Electric customer support.
bYL	Bypass loss.	Check if the input voltage is within the Bypass range.
UNF	Inverter voltage is too high.	If the UPS does not recover automatically, contact APC by Schneider Electric customer support.
LNf	Inverter voltage is too low.	If the UPS does not recover automatically, contact APC by Schneider Electric customer support.
CF	Internal communication failure.	If the UPS does not recover automatically, contact APC by Schneider Electric customer support.

Contact APC by Schneider Electric customer support for all other alarm codes.

Emergency Power Off

NOTICE

RISK OF EQUIPMENT DAMAGE

- Adhere to all national and local electric codes.
- All electrical work must be performed by a qualified electrician.
- Do not connect the EPO interface to any circuit other than an unused circuit.

Failure to follow these instructions can result in equipment damage.

The Emergency Power Off (EPO) function is a feature that will immediately disconnect power to all connected equipment.

Adhere to all national and local electrical codes. Wiring must be performed by a qualified electrician.

The EPO switch is internally powered by the UPS for use with non-powered switches or potential free contacts.

Normally closed (N/C) contacts

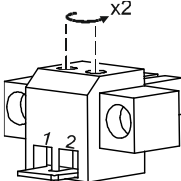
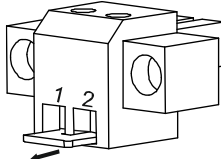
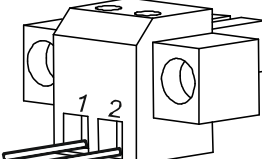
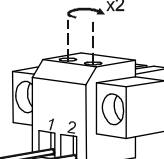
1	Loosen the screws of terminals 1 and 2 in the EPO connector. 	2	Remove the metal link between pins 1 and 2. 
3	Connect N/C relay contacts between pins 1 and 2 of the EPO terminal block. Use 0.5 to 1 mm ² wire. 	4	Secure the terminal screws in the EPO connector (Torque: 3 kgf.cm) 

NOTE: If the N/C is open, the UPS will turn off and the connected load will not receive power from the UPS.

Use Class 2 cable (CL2) to connect the Easy UPS to the EPO switch.

The EPO interface is a Safety Extra Low Voltage (SELV) circuit. Connect it only to other SELV circuits. The EPO interface monitors circuits that have no determined voltage potential. Such closure circuits may be provided by a switch or relay properly isolated from the utility. To avoid damage to the UPS, do not connect the EPO interface to any circuit other than an unused circuit.

Use one of the following cable types to connect the UPS to the EPO switch.

- CL2: Class 2 cable for general use.
- CL2P: Plenum cable for use in ducts, plenums, and other spaces used for environmental air.
- CL2R: Riser cable for use in a vertical run in a floor-to-floor shaft.
- CLEX: Limited use cable for use in dwellings and for use in raceways.

Troubleshooting

Use the table below to solve minor installation and operation problems. Refer to the APC by Schneider Electric website, www.apc.com for assistance with complex UPS problems.

Problem and/or Possible Cause	Solution
UPS is not turning on.	
POWER ON/OFF button not pressed properly.	Press the POWER ON/OFF button for one second. Release the button when the UPS emits a single beep. The UPS will start up.
The UPS is not connected to utility power supply.	Be sure that the power cord from the UPS to the utility power supply is securely connected at both ends.
UPS is not turning off.	
POWER OFF button not pressed properly	Press POWER ON/OFF button for one second. Release the button immediately when the UPS emits a single beep. The UPS will power off and LCD display will turn off in 2 minutes. Be sure that the LCD display is not illuminated before restarting the UPS.
Utility input power is available.	UPS logic power can not be turned off if utility input power is available. To turn off the UPS, turn off utility input power and press  button. Release when a beep is heard.
UPS is not supplying power to the connected equipment when operating on Battery mode.	
The battery is not connected.	<ol style="list-style-type: none"> 1. Be sure that battery cable is properly secured at both the UPS and the battery pack. 2. Be sure that the first battery pack (master battery pack) ID switch is set to 0 and all IDs should be set differently.
The UPS can not be turned on.	If the UPS has shutdown (the display is not illuminated), follow the procedure “Cold start the UPS” on page 17.
Low battery cut off.	UPS may have discharged the battery due to utility power outage and turned the output off due to low battery condition. Wait for the utility power to return and charge the battery.
Battery temperature is not within specifications (cell temperature lesser than -20 °C or greater than 80 °C).	Be sure the air vents on the battery pack are not blocked and adequate space for proper ventilation is available.
The battery pack is experiencing an overload condition.	Disconnect nonessential equipment from the UPS to correct the overload condition.
Battery output terminals are short circuited.	Remove the short circuit at the output terminals of the battery and charge the battery.
Communication wires are not properly connected between UPS and battery packs.	Be sure that the communication wires between the UPS and the battery packs are properly secured.

Problem and/or Possible Cause	Solution
The UPS is operating on battery, while connected to the input utility power.	
There is high, low, or distorted input voltage or frequency.	Connect the UPS to a different outlet on a different circuit. Test the utility input power to be sure the unit is receiving input power. If display is illuminated, navigate and check the input voltage and frequency.
Battery is not getting charged when UPS is working Online mode.	
Battery temperature is not within specifications (cell temperature lesser than -20 °C or greater than 80 °C).	Be sure the air vents on the battery pack are not blocked and adequate space for proper ventilation is available.
UPS is not providing expected backup time.	
The UPS battery is discharged due to a recent power outage.	The batteries require recharging after extended outages. Batteries can wear faster when put into service without being fully charged or when operated at elevated temperatures.
The battery is near the end of its service life.	If the battery is near the end of its service life, consider replacing the battery, even if the replace battery indicator is not illuminated. Refer “Start up” on page 17 for details.
UPS is in Bypass mode and the LED is not illuminated red.	
UPS is in green mode.	Disable green mode if not desired.
UPS is configured to stay in the bypass mode.	Change the configuration to exit bypass mode.
UPS is in bypass mode even after overload temperature alarm is cleared.	Reduce the connected load to <70% to bring the UPS to online mode.
The UPS has experienced an overload condition and transferred to bypass.	Connected equipment exceeds the “maximum load” as defined in specifications on the APC by Schneider Electric Website, www.apc.com . The UPS continues to supply power as long as it is in bypass mode and the circuit breaker does not trip. Disconnect nonessential equipment from the UPS to eliminate the overload condition.
UPS has detected an internal error and transferred to bypass.	Refer “Alarms and System Events” on page 21 for details.
No audible sounds from UPS even when the Alert LED is illuminated.	
Audible alarm is disabled.	Change the UPS configuration to enable audible alarms.
Alarm LED is illuminated. The UPS displays an alarm message and emits a constant beeping sound.	
The UPS has detected an internal error.	Refer “Alarms and System Events” on page 21 for details.

Transport

1. Shut down and disconnect all connected equipment.
2. Disconnect the unit from mains power.
3. Disconnect all internal and external batteries (if applicable).
4. Follow the shipping instructions outlined in the *Service* section of this manual.

Service

If the unit requires service, do not return it to the dealer. Follow these steps:

1. Review the *Troubleshooting* section of the manual to eliminate common problems.
2. If the problem persists, contact APC by Schneider Electric Customer Support through the APC by Schneider Electric website, **www.apc.com**.
 - a. Note the model number and serial number and the date of purchase. The model and serial numbers are located on the rear panel of the unit.
 - b. Call Customer Support. A technician will attempt to solve the problem over the phone. If this is not possible, the technician will issue a Returned Material Authorization Number (RMA#).
 - c. If the unit is under warranty, the repairs are free.
 - d. Service procedures and returns may vary internationally. For country specific instructions refer to the APC by Schneider Electric website, **www.apc.com**.
3. Pack the unit properly to avoid damage in transit. Never use foam beads for packaging. Damage sustained in transit is not covered under warranty.
4. Write the RMA# provided by Customer Support on the outside of the package.
5. Return the unit by insured, prepaid carrier to the address provided by Customer Support.
6. Shipment of Lithium Ion Battery is highly regulated and the regulation is evolving. Pack the battery and UPS separately. Always contact Customer Support to get the latest guidance on shipment of Lithium ion battery and UPS.

Limited Factory Warranty

Schneider Electric IT Corporation (SEIT), warrants its products to be free from defects in materials and workmanship for a period of three (3) years from the date of purchase. The SEIT obligation under this warranty is limited to repairing or replacing, at its own sole option, any such defective products. Repair or replacement of a defective product or part thereof does not extend the original warranty period.

This warranty applies only to the original purchaser who must have properly registered the product within 10 days of purchase. Products may be registered online at warranty.apc.com.

SEIT shall not be liable under the warranty if its testing and examination disclose that the alleged defect in the product does not exist or was caused by end user or any third person misuse, negligence, improper installation, testing, operation or use of the product contrary to SEIT recommendations of specifications. Further, SEIT shall not be liable for defects resulting from: 1) unauthorized attempts to repair or modify the product, 2) incorrect or inadequate electrical voltage or connection, 3) inappropriate on site operation conditions, 4) Acts of God, 5) exposure to the elements, or 6) theft. In no event shall SEIT have any liability under this warranty for any product where the serial number has been altered, defaced, or removed.

EXCEPT AS SET FORTH ABOVE, THERE ARE NO WARRANTIES, EXPRESS OR IMPLIED, BY OPERATION OF LAW OR OTHERWISE, APPLICABLE TO PRODUCTS SOLD, SERVICED OR FURNISHED UNDER THIS AGREEMENT OR IN CONNECTION HERewith.

SEIT DISCLAIMS ALL IMPLIED WARRANTIES OF MERCHANTABILITY, SATISFACTION AND FITNESS FOR A PARTICULAR PURPOSE.

SEIT EXPRESS WARRANTIES WILL NOT BE ENLARGED, DIMINISHED, OR AFFECTED BY AND NO OBLIGATION OR LIABILITY WILL ARISE OUT OF, SEIT RENDERING OF TECHNICAL OR OTHER ADVICE OR SERVICE IN CONNECTION WITH THE PRODUCTS.

THE FOREGOING WARRANTIES AND REMEDIES ARE EXCLUSIVE AND IN LIEU OF ALL OTHER WARRANTIES AND REMEDIES. THE WARRANTIES SET FORTH ABOVE CONSTITUTE SEIT'S SOLE LIABILITY AND PURCHASER EXCLUSIVE REMEDY FOR ANY BREACH OF SUCH WARRANTIES. SEIT WARRANTIES EXTEND ONLY TO ORIGINAL PURCHASER AND ARE NOT EXTENDED TO ANY THIRD PARTIES.

IN NO EVENT SHALL SEIT, ITS OFFICERS, DIRECTORS, AFFILIATES OR EMPLOYEES BE LIABLE FOR ANY FORM OF INDIRECT, SPECIAL, CONSEQUENTIAL OR PUNITIVE DAMAGES, ARISING OUT OF THE USE, SERVICE OR INSTALLATION OF THE PRODUCTS, WHETHER SUCH DAMAGES ARISE IN CONTRACT OR TORT, IRRESPECTIVE OF FAULT, NEGLIGENCE OR STRICT LIABILITY OR WHETHER SEIT HAS BEEN ADVISED IN ADVANCE OF THE POSSIBILITY OF SUCH DAMAGES. SPECIFICALLY, SEIT IS NOT LIABLE FOR ANY COSTS, SUCH AS LOST PROFITS OR REVENUE, WHETHER DIRECT OR INDIRECT, LOSS OF EQUIPMENT, LOSS OF USE OF EQUIPMENT, LOSS OF SOFTWARE, LOSS OF DATA, COSTS OF SUBSTITUANTS, CLAIMS BY THIRD PARTIES, OR OTHERWISE.

NOTHING IN THIS LIMITED WARRANTY SHALL SEEK TO EXCLUDE OR LIMIT SEIT LIABILITY FOR DEATH OR PERSONAL INJURY RESULTING FROM ITS NEGLIGENCE OR ITS FRAUDULENT MISREPRESENTATION OF TO THE EXTENT THAT IT CANNOT BE EXCLUDED OR LIMITED BY APPLICABLE LAW.

To obtain service under warranty you must obtain a Returned Material Authorization (RMA) number from customer support. Customers with warranty claims issues may access the SEIT worldwide customer support network through the APC by Schneider Electric website: www.apc.com. Select your country from the country selection drop down menu. Open the Support tab at the top of the web page to obtain information for customer support in your region. Products must be returned with transportation charges prepaid and must be accompanied by a brief description of the problem encountered and proof of date and place of purchase.

APC by Schneider Electric Worldwide Customer Support

Customer support for this or any other APC by Schneider Electric product is available at no charge in any of the following ways:

- Visit the APC by Schneider Electric website to access documents in the APC by Schneider Electric Knowledge Base and to submit customer support requests.
 - **www.apc.com** (Corporate Headquarters)
Connect to localized APC by Schneider Electric websites for specific countries, each of which provides customer support information.
 - **www.apc.com/support/**
Global support searching APC by Schneider Electric Knowledge Base and using e-support.
- Contact the APC by Schneider Electric Customer Support Center by telephone or e-mail.
 - Local, country specific centers: go to **www.apc.com/support/contact** for contact information.

For information on how to obtain local customer support, contact the APC by Schneider Electric representative or other distributor from whom you purchased your APC by Schneider Electric product.