

# Symmetra® LX

## Uninterruptible Power Supply

200 V, 4–8 kVA

208/240 V, 4–8 kVA

220/230/240 V, 4–8 kVA

200 V, 4–16 kVA

208/240 V, 4–16 kVA

220/230/240 V, 4–16 kVA

Tower / Rack-Mount

### Start UP Guide

EN 990-1546C

09/2025

# APC™

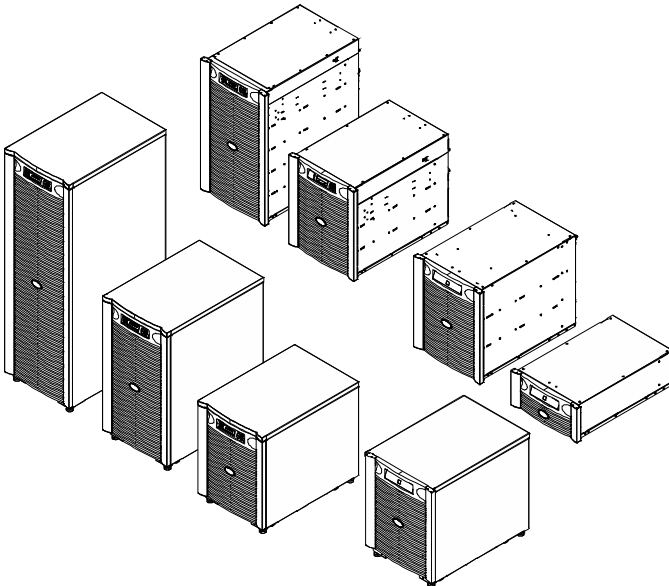

**Schneider**  
Electric™

# Legal Information

The APC brand and any trademarks of Schneider Electric SE and its subsidiaries referred to in this guide are the property of Schneider Electric SE or its subsidiaries. All other brands may be trademarks of their respective owners.

This guide and its content are protected under applicable copyright laws and furnished for informational use only. No part of this guide may be reproduced or transmitted in any form or by any means (electronic, mechanical, photocopying, recording, or otherwise), for any purpose, without the prior written permission of Schneider Electric.

Schneider Electric does not grant any right or license for commercial use of the guide or its content, except for a non-exclusive and personal license to consult it on an "as is" basis. APC products and equipment should be installed, operated, serviced, and maintained only by qualified personnel.

As standards, specifications, and designs change from time to time, information contained in this guide may be subject to change without notice.

To the extent permitted by applicable law, no responsibility or liability is assumed by Schneider Electric and its subsidiaries for any errors or omissions in the informational content of this material or consequences arising out of or resulting from the use of the information contained herein.

## Important Safety Instructions

SAVE THESE INSTRUCTIONS - This manual contains important instructions that should be followed during installation and maintenance of the UPS and batteries.



Read the Safety Guide supplied with the equipment to become familiar with the safety requirements before trying to install or operate the UPS.

Read the user documentation to become familiar with the equipment before trying to install or operate it.

The following special messages may appear throughout this document or on the equipment to warn of potential hazards or to call attention to information that clarifies or simplifies a procedure.



The addition of this symbol either to a “Danger” or “Warning” safety label indicates that an electrical hazard exists that will result in personal injury if the instructions are not followed.



This is the safety alert symbol. It is used to alert you to potential personal injury hazards. Obey all safety messages that follow this symbol to avoid possible injury or death.

### DANGER

**DANGER** indicates a hazardous situation which, if not avoided, **will result in death** or serious injury.

### WARNING

**WARNING** indicates a hazardous situation which, if not avoided, **could result in death** or serious injury.







### CAUTION

**CAUTION** indicates a hazardous situation which, if not avoided, **could result in minor or moderate injury**.

### NOTICE

**NOTICE** is used to address practices not related to physical injury.

## Product Handling Guidelines

 <18 kg <40 lb	 18-32 kg 40-70 lb	 32-55 kg 70-120 lb	 >55 kg >120 lb		
---	---	--	---	---	---

Electrical equipment should be installed operated and maintained only by qualified personnel. No responsibility is assumed by Schneider Electric for any consequences arising out of the use of this material.

A qualified person is one who has skills and knowledge related to the construction, installation, and operation of electrical equipment and has received safety training to recognize and avoid the hazards involved.

## Safety and General Information

**Inspect the package contents upon receipt. Notify the carrier and dealer if there is any damage.**

**Additional safety information can be found in the Safety Guide supplied with this unit.**

- This equipment is for use in a restricted access location.
- Adhere to all national and local electrical codes.
- All wiring must be performed by a qualified electrician.
- Do not work alone under hazardous conditions.
- **Changes and modifications to this unit not expressly approved by Schneider Electric IT Corporation could void the warranty.**
- This UPS is intended for indoor use only.
- Do not operate this unit in direct sunlight, in contact with fluids, or where there is excessive dust or humidity.
- Be sure the air vents on the UPS are not blocked. Allow adequate space for proper ventilation.
- For a UPS with a factory installed power cord, connect the UPS power cable directly to a wall outlet. Do not use surge protectors or extension cords.
- The equipment is heavy. Always practice safe lifting techniques adequate for the weight of the equipment.
- The batteries are heavy. Remove the batteries before installing the UPS and external battery packs (XLBPs), in a rack.
- Always install XLBPs at the bottom in rack-mount configurations. The UPS must be installed above the XLBPs.
- Always install peripheral equipment above the UPS in rack-mount configurations.

### Electrical safety

- Do not handle any metallic connector before power has been disconnected.
- For models with a hardwired input, the connection to the branch circuit (mains) must be performed by a qualified electrician.
- In order to comply with the EMC regulations, wherever applicable, output cords and network cables attached to the UPS must not exceed 10 meters in length.
- The protective earth conductor for the UPS carries the leakage current from the load devices (computer equipment). An insulated ground conductor is to be installed as part of the branch circuit that supplies the UPS. The conductor must have the same size and insulation material as the grounded and ungrounded branch circuit supply conductors. The conductor will typically be green, with or without a yellow stripe.
- Leakage current for a pluggable, Type A UPS may exceed 3.5 mA when a separate ground terminal is used.
- The UPS input ground conductor must be properly bonded to protective earth at the service panel.
- If the UPS input power is supplied by a separately derived system, the ground conductor must be properly bonded at the supply transformer or motor generator set.

## Battery safety

### **WARNING**

#### **RISK OF HYDROGEN SULPHIDE GAS, EXCESSIVE SMOKE AND FIRE**

- Replace the battery at least every 5 years or at the end of its service life, whichever is earlier.
- Replace the battery immediately when the UPS indicates battery replacement is necessary.
- Replace batteries with the same number and type of batteries as originally installed in the equipment.
- Replace the battery immediately when:
  - The UPS indicates a battery over-temperature condition.
  - There is evidence of electrolyte leakage.
  - The UPS indicates any battery related alarm on a battery near the end of its service life.

For any of these conditions, power off the UPS, unplug it from the AC input, and disconnect the batteries.

- Do not operate the UPS until the batteries have been replaced.
- \*Replace all battery modules (including the modules in External Battery Packs) which are older than one year, when installing additional battery packs or replacing the battery module(s).

**Failure to follow these instructions could result in death, or serious injury and equipment damage.**

\*Contact Schneider Electric Customer Support to determine the age of the installed battery modules.

- Batteries typically last for two to five years. Environmental factors impact battery life. Elevated ambient temperatures, poor quality utility power causing frequent short duration discharges will shorten battery life. Batteries should be replaced before end of life.
- Schneider Electric uses Maintenance-Free sealed Lead Acid batteries. Under normal use and handling, there is no contact with the internal components of the battery. Over charging, over heating or other misuse of batteries can result in a discharge of battery electrolyte. Released electrolyte is toxic and may be harmful to the skin and eyes.
- CAUTION: A battery can present a risk of electrical shock and high short circuit current. The following precautions should be observed when working on batteries:
  - Disconnect the charging source prior to connecting or disconnecting battery terminals.
  - Do not wear any metal objects including watches and rings. High short circuit current through conductive materials could cause severe burns.
  - Do not lay tools or metal parts on top of batteries.
  - Use tools with insulated handles.
  - Wear rubber gloves and boots.
- CAUTION: Do not dispose of batteries in a fire. The batteries may explode.
- CAUTION: Do not open or mutilate batteries. Released material is harmful to the skin and eyes and may be toxic.

## Hardwire safety

- Check that all branch circuit (mains) and low voltage (control) circuits are deenergized, and locked out before installing cables or making connections, whether in the junction box or to the UPS.
- All wiring must be performed by a qualified electrician.
- Select wire size and connectors according to national and local codes.
- Wiring must be approved by a local wiring inspector.
- Strain relief is required for all hardwiring (supplied with select products). Snap in type strain reliefs are recommended.
- All openings that allow access to UPS hardwire terminals must be covered. Failure to do so may result in personal injury or equipment damage.

## De-energizing safety

- The UPS contains internal batteries and may present a shock hazard even when disconnected from AC and DC power.
- The AC and DC output connectors may be energized by remote or automatic control at any time.
- Before installing or servicing the equipment perform the following tasks:
  - Set the System enable switch to the OFF position.
  - Set the input circuit breaker to the OFF position.
  - Disconnect the battery modules.
  - Disconnect external battery cabinet if provided.
  - Disconnect mains/branch circuit.

## General information

- The model and serial numbers are located on a label in the rear panel. For some models, an additional label is located on the chassis under the front bezel.
- Always recycle used batteries.
- Recycle the package materials or save them for reuse.

## Overview

This manual provides an overview of operations for the Symmetra™ LX and Extended Run Cabinet, including detailed explanations of monitoring, control, and configuration through the PowerView user interface.

Illustrations are representative. Your unit and configuration, including components and optional Schneider Electric equipment, may vary from those depicted in this document. Manuals may be accessed through the Schneider Electric web site, [www.se.com](http://www.se.com).

**PowerView**

PowerView contains an alphanumeric display, navigation keys, status indicators, and an audible alarm.

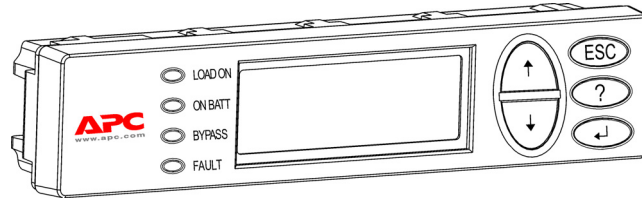

The tables below describe the status indicators and navigation keys.

**Keys and Indicators**

Status Indicator	Color	Status
<b>LOAD ON</b>	Green	The UPS is supplying power to the load. It may be operating in any one of the following modes: On-Line, On-Battery, Command-Bypass, or Maintenance.
<b>ON BATT</b>	Yellow	A mains power failure has occurred, and the battery modules are supplying power to the load equipment.
<b>BYPASS</b>	Yellow	Power to the load is being supplied directly by the mains power source. The UPS is removed from the circuit.
<b>FAULT</b>	Red	The UPS has detected an internal fault. A visible alarm message will appear on the PowerView display.

Navigation Keys	Name	Sound	Function
↑	Up	Short beep	Moves the selection arrow upward.
↓	Down	Short beep	Moves the selection arrow downward.
ESC	Escape	Short beep	Exits the current screen and returns to the previous screen. Programming mode only: when pressed until a short beep (up to one second) occurs, it exits the programming mode.
?	Help	Short beep	Opens context-sensitive help.
↵	Enter	Short beep	Opens the selected menu item or setting.
ESC + ? + ↵	Escape + Help + Enter	Two short beeps	When pressed simultaneously for about 1 second, resets the PowerView RM interface.
		One long beep	When pressed simultaneously for about 3 seconds, puts the interface in programming mode for installing new language program files.

## Navigation

The normal display on the PowerView is the monitoring screen shown below. A snapshot of the UPS status is provided. Pressing 'ESC' multiple times will always allow return to this display.

Chrg 100%
Load 20%
206Vin 208Vout 60Hz
Runtime: 00hr 27min

From the monitoring screen, press 'ESC' to get to the Main Menu.

Control	Logging
Status	Display
>Setup	Diags
Accessories	Help

The Main Menu provides access to each of the different function groups provided below. Use the navigation keys to select the desired group. "Menu Commands" on page 15 in this manual provides detailed descriptions of each functional group and its associated commands.

Menu	Description
Control	Provides power control commands, such as Load ON and Load OFF.
Status	Displays information regarding load, battery and power modules, voltage, and electrical current.
Setup	Allows the user to customize the UPS functionality.
Accessories	Allows monitoring of installed APC accessories, if they are present.
Logging	Provides ability to log system events.
Display	Allows configuration of PowerView display settings.
Diagnostics	Provides detailed information useful in troubleshooting the system.
Help	Provides access to help information.

# Basic Commands

⚠ **DANGER**

**RISK OF ELECTRIC SHOCK**

- Adhere to all national and local electrical codes.
- Wiring must be performed by a qualified electrician.
- Read and follow all safety and installation instructions in this manual.

**Failure to follow these instructions could result in equipment damage, personal injury or death.**

## Supply Power to the UPS

This procedure supplies power to the Symmetra LX and does not supply power to the equipment connected to the UPS.

- 1 Turn ON AC utility power to the UPS.
- 2 Switch ON the circuit breakers for all connected equipment.
  - a. If connected equipment is hardwired, check that the output circuit breakers in the distribution panel are turned ON.
  - b. If connected equipment is plugged into the UPS **A**, check that each UPS PDU output circuit breaker **B** is switched ON.
- 3 Turn ON the UPS input circuit breaker **C**.
- 4 Turn ON the UPS System Enable switch **D**.

**NOTE:** To start the UPS when there is no AC utility power present, press and hold either of the cold start buttons **E** for four seconds.

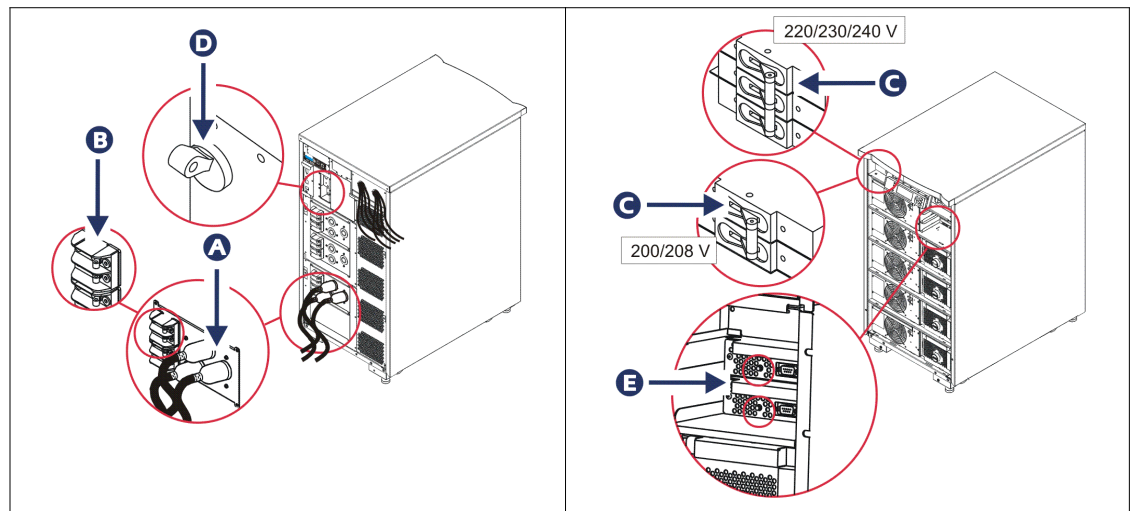

After initialization, the monitoring screen appears, providing a view of operating parameters.

Chg	100%
Load	000%
220 Vin	000 Vout, 60 Hz
Runtime	00hr 30min

## Set the Correct Output Voltage

- 1 Press the **Esc** button until the Main Menu appears. Use the up and down arrow keys to choose 'Setup', and ENTER to select.

Control	Logging
Status	Display
>Setup	Diags
Accessories	Help

- 2 Use the arrow keys and ENTER to select 'Other'.

Settings	Alarms
Shutdown	Bypass
Defaults	Copy
Output Freq	>Other

- 3 If the output voltage is not correct for your application, use the arrow keys, and ENTER to select 'Output'. The cursor will move to the voltage field, as the up and down arrows scroll through available choices. Choose the desired voltage setting and press ENTER to select.

Self Test	Enabled
UPS ID	UPS_IDEN
Vout Reporting	AUTO
>Output	208V

## Supply Power to the Load Equipment

The Symmetra LX must be turned on before executing this procedure.

- 1 Press 'ESC' until the Main Menu appears. Use the arrow keys to choose 'Control' and ENTER to select.

> Control	Logging
Status	Display
Setup	Diags
Accessories	Help

- 2 Use the arrow keys to choose 'TURN UPS OUTPUT ON' and ENTER to select.  
**NOTE:** You must scroll to a second page of choices.

Graceful Turn Off
Start Runtime Cal
>Turn UPS Output On

- 3 Confirm choice by selecting 'YES'.

Confirm:
Turn UPS On
CANCEL
>YES, Turn UPS On

- 4 There will be clicking sounds and this message will appear.  
**NOTE:** You may be given one or more override alerts. Answer these by selecting 'Start Now'.

```
UPS HAS BEEN
COMMANDED TO TURN
LOAD POWER ON
```

- 5 In approximately 90 seconds, the green Load On indicator will illuminate and this message will appear.

```
UPS LOAD IS ON
Press any key...
```

## Turn Off UPS Output Power and Load Equipment

- 1 Press 'Esc' until the Main Menu appears.

```
> Control           Logging
Status             Display
Setup              Diags
Accessories        Help
```

- 2 Scroll down and select the 'Turn UPS Output Off' command.

```
Graceful Turn Off
Start Runtime Cal
>Turn UPS Output Off
```

- 3 Confirm choice by selecting 'YES'.

```
Confirm:
Turn UPS Off
NO, ABORT
>YES, Turn UPS Off
```

- a. You will hear some clicking sounds and see the following message.

```
UPS HAS BEEN
COMMANDED TO TURN
LOAD POWER OFF
```

- b. In approximately 90 seconds, you will see the following message and the green Load On status indicator will be OFF. The output is now off.

```
UPS LOAD IS OFF
Press any key...
```

- 4 To fully remove power from the UPS, turn OFF the system enable switch, and open the input circuit breaker.

## Bypass Operation

The bypass operation can be performed manually, using the maintenance bypass switch, or automatically, using the PowerView to issue commands.

**NOTE:** In either bypass mode, the utility and circuit breakers must be turned on.

**NOTE:** The UPS must remain functional to stay in command bypass mode. Put the UPS in maintenance bypass before turning off the system enable switch, or removing both intelligence modules.

### Command Bypass

Command Bypass requires utilization of the commands on the PowerView display. This mode is used to bypass the UPS electronics and directly supply power to the load.

Follow the steps below to directly connect the output power of the UPS to the branch circuit (mains) using the command bypass mode.

- 1 Press 'Esc' to view the Main Menu, and select 'Control'.

```
> Control          Logging
Status            Display
Setup             Diags
Accessories       Help
```

- 2 Scroll down and select the 'UPS into Bypass' command.

```
>UPS into Bypass
  Do Self Test
  Simulate Power Fail
  Graceful Reboot ↓
```

- 3 Confirm choice by selecting 'YES'.

```
Confirm:
UPS into Bypass
NO, ABORT
>YES, UPS into Bypass
```

- a. You will see the following message. The green Load On and yellow Bypass status indicators will be on as well.

```
UPS IS BYPASSED
Press any key...
```

## Maintenance Bypass

Maintenance Bypass is used to manually bypass the UPS and directly supply power to the load while the input circuit breaker is turned ON.

Follow the steps below to directly connect the output power of the UPS to the branch circuit (mains) using the maintenance bypass mode.

- 1 Check that the input circuit breaker is turned ON.

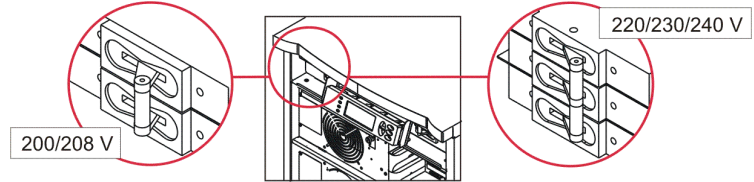

- 2 Turn ON the maintenance bypass switch.

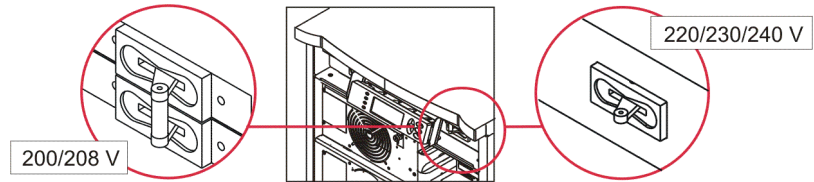

## Language Setting

The factory default language of the user interface is English. You can change the language by downloading new firmware into the PowerView. French, German, Italian, and Spanish are available on the enclosed CD. Visit the Schneider Electric web site at <http://www.se.com> for multilingual product documentation and firmware language support.

Illustrations are representative. Your configuration may be different from the models shown in this procedure.

To change the user interface language, perform the following steps.

- 1 Grab onto the door tabs **A**, gently pull forward, and then up to remove the door.
- 2 Remove the PowerView display by removing the screws **B** and display from the frame.

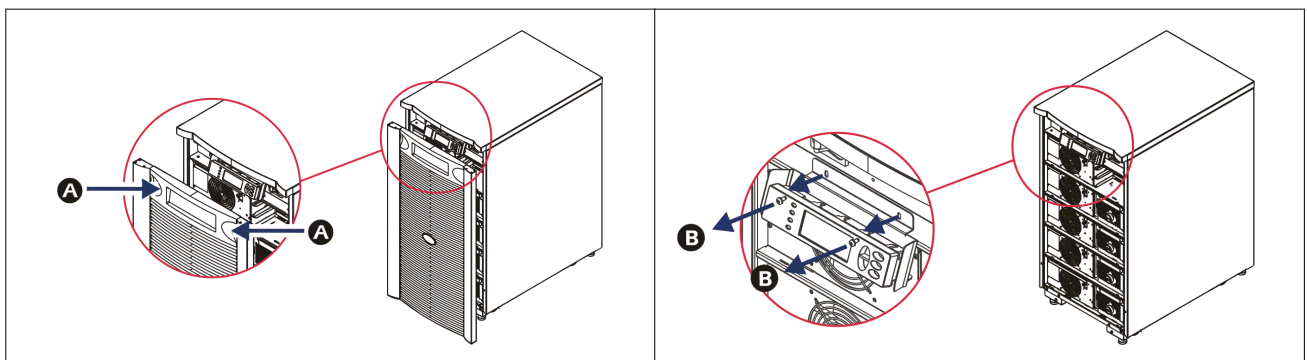

- 3 Remove the screws **C** securing the display bracket to the PowerView.

- 4 Disconnect the UPS cable **D** from the RJ-45 port on the PowerView.

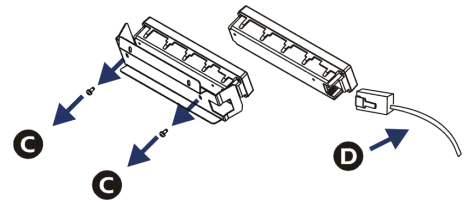

- 5 Connect the programming cable **E** (included) between the PowerView and the UPS cable.
- Attach the RJ-45 connector to the port on the rear of the PowerView.
  - Connect the female DB-9 connector of the programming cable to a serial port on the computer.
  - The computer must have internet access to download languages.
  - Attach the UPS cable to the female RJ-45 connector on the programming cable.

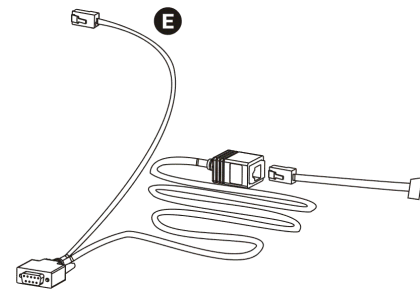

- 6 Locate the language program file to be downloaded into the UPS. See the Schneider Electric web site at <http://www.se.com/support> and download the desired language.
- 7 Place the PowerView in programming mode simultaneously pressing the three keys on the right ('Esc', 'Help', and 'ENTER') for approximately three seconds, until the PowerView emits a long beep.
- The LCD will display the Programming screen.
  - To leave the Programming screen before starting a file transfer (Step 6), press 'ESC' until the beep (about one second).
- 8 Start HyperTerminal or another terminal emulation program on the computer.
- Set the communication parameters to 8 bits, no parity, no flow control, 1 stop bit, and 19,200 bps.
  - After establishing a connection, use the Xmodem protocol to transfer the language program file from PowerView.
  - When the file transfer is complete, the PowerView will reset itself and display the Start-Up screen in the new language.
- 9 If the file transfer fails, PowerView will reset itself. Retry the file transfer by repeating Step 6 and Step 7.
- 10 Quit the terminal session.
- 11 Disconnect the programming cable on the PowerView RJ-45 port.
- 12 Connect the UPS cable to the PowerView RJ-45 port.
- 13 Install the display bracket to the rear of the PowerView by securing the two screws to the display.
- 14 With two hands, grip the display and gently snap the tabs onto the frame.
- 15 Secure the PowerView display by tightening the two screws to the UPS frame.

## Menu Commands

The following sections describe the details of each command. Commands are organized according to the menu hierarchy in the PowerView.

### Accessories Menu

The Accessories Menu allows you to monitor Schneider Electric accessories if they are installed. The PowerView must be connected to the computer interface port at the back of the UPS frame in order to monitor internal accessories.

### Control Menu

Use the Control Menu and its submenus to control power flows to and from the UPS.

Menu Item	Function
Turn UPS Output On/Off	Controls the delivery of output power to the connected equipment.
Do Self Test	Initiates a system of self-testing and diagnostics. An error message is displayed when a problem is detected.
Simulate Power Fail(ure)	Simulates a power failure/return to test the server recognition of the failure event.
Graceful Reboot	Initiates a signal for the server to shutdown. After user-defined "Low-Battery Duration" plus "Shutdown Delay," the output power is switched off for the duration of the user-defined "Return Delay." The output power is then switched on again. See Setup-Shutdown to set these time delays. PowerChute software must be used on the server for proper shutdown.
Graceful Turn Off	Initiates a signal for the server to shut down. After the user-defined "Low-Battery Duration" plus "Shutdown Delay," the output power is switched off. Use Setup-Shutdown to set these times. PowerChute software must be used on the server for it to be properly shutdown.
Start/Stop Runtime Cal(ibration)	Calculates an accurate battery runtime measurement. Delivers load output power from battery source. Discharges battery to 25% of capacity. Battery capacity must be at 100% to execute this test.
UPS into/out of Bypass	Controls the bypass function. When in bypass mode, power is delivered directly from the utility source to load equipment.

### Display Menu

The Display Menu allows the user to customize the PowerView display.

Menu Item	Function	Options
Date/Time	Sets the correct date and time.	Date: dd-mmm-yyyy Ex: 11-Aug-2003 Time: hh:mm:ss Ex: 21:36:10
Password	Protects against unauthorized configuration changes.	
Password	Sets a password.	Valid characters include: A–Z, or 0–9 Type '_' to complete.

Menu Item	Function	Options
Timeout	Sets the inactivity timer.	1, 2, 5, 10 (default); 30 minutes; 1, 2, or 4 Hours; or Forever
Invalidate	Puts password into effect. Prevents unauthorized changes to the UPS configuration.	
Information	Displays PowerView model number, serial number, date of manufacture, and revision information.	
Beeper	Sets audible alarm (beeper) criteria.	
At UPS	Not used with the UPS.	
At Display	Sets parameters for the audible alarm in the PowerView.	Power Failure, Power Failure + 30 seconds, Low Battery, or Never
Volume	Sets audible alarm volume.	Off, Low (default), Medium, or High
Click	Sets sound when pressing display buttons.	On (default), Off
Contrast	Sets LCD screen contrast.	0, 1, 2, 3, 4, 5, 6, or 7
Config	Customizes the information displayed on the Startup screen.	Use factory defaults when possible.

## Diagnostics Menu

The Diagnostics Menu provides useful information for troubleshooting.

Menu Item	Function
Fault and Diagnostics	Displays current system alert and diagnostic information of that alert.
(Main) Intelligence Module	Displays detailed intelligence module status and information.
Redundant Intelligence Module	Displays detailed redundant intelligence module status and information.
Power Modules	Displays detailed power module status and information.
Batteries	Displays detailed battery module status and information.

## Help Menu

To access PowerView online help screens, press the 'Scroll Up' and 'Scroll Down' keys simultaneously to access context sensitive help.

## Logging Menu

The Logging Menu allows the user to customize the UPS log.

Menu Item	Function
View Log	Logs the most recent 64 events. Point to an entry and press 'ENTER' for more information on that event.
View Statistics	Records the total number of transfers to battery, low battery, alerts, and on battery runtime events.

Menu Item	Function
Configure Logging	Allows different types of events to be included or excluded from the log. Event types include Power Events, UPS Controls, UPS alerts, and User Activity.
Power Events	On (default), Off
UPS Control	
UPS Faults	
User Activity	
Measure UPS Events	
List Event Groups	Lists the specific events in each group.
Power Events	
UPS Control Events	
User Activities	
UPS Fault	
Measure UPS Events	
Clear Log	Clears the view log. Does not clear the active event lists.

## Status Menu

The Status Menu displays load, battery/power module, voltage, and electrical current information.

Menu Item	Function
Ø Vin Vout Iout	Displays input voltage(s), output voltage(s), and output current information.
% load assuming no redundancy	Compares the current load to the total capacity of all power modules.
% load allowing for n+ redundancy	Compares the current load to the total capacity of all power modules, except the power modules that are set aside by the "Fault Tolerance" alarm threshold. For example, if there are four power modules installed, and the Fault tolerance alarm threshold is set to "1," this percentage of load uses only three power modules for the calculation. See Setup > Alarms to set the redundancy level.
Frequencies	Displays the measured input and output frequencies.
Battery Status Screen	Displays battery module capacity, runtime, and status information.
Power Module Status Screen	Displays power module capacity, fault tolerance, and status information.
Alarm Thresholds Status Screen	Displays the user-defined alarm settings. See Setup > Alarms to set these alarm thresholds.
Miscellaneous Status Screen	Displays the summary result Self-Test, Last System Transfer, Operating Mode, and status of intelligence and redundant intelligence modules.

## Setup Menu

The Setup Menu allows the user to customize the UPS functionality.

Menu Item	Function	Options
Shutdown	Sets the shutdown parameters in the event of a utility power failure.	None
Low Batt(ery) Dur(ation)	Sets the number of minutes an audible alarm sounds before the UPS shuts down due to battery exhaustion.	2 (default), 5, 7, 10, 12, 15, 18, or 20 minutes
Shutdown Delay	Sets the additional runtime for computer issuing shutdown command if it needs additional time to shut itself down.	0, 20 (default), 60, 120, 240, 480, 720, or 960 seconds
Return Delay	Sets the delay interval that allows utility power to stabilize before the system goes back online after a utility power failure.	0 (default), 20, 60, 120, 240, 480, 720, or 960 seconds
Return Battery Capacity	Sets the minimum battery capacity necessary before repowering the load when returning from an extended utility power failure.	0% (default), 15%, 25%, 35%, 50%, 60%, 75%, or 90%
Defaults	Sets all settings to factory defaults.	
Output Freq(uecy)	The UPS output will phase lock to the input within this range.	50±3 Hz, 50±0.1 Hz, 60±3 Hz, 60±0.1 Hz, Full range tracking
Alarms	Sets the alarm thresholds.	None
Redundancy	An audible alarm sounds if the redundancy falls below this level.	0 (default), 1, or 2
Load	An audible alarm sounds when the load exceeds this limit. (Upper value is limited by the maximum power of the UPS.)	Never (default), 1, 2, 3, 4, 5, 6, 7, 8, 9, 10, or 12 kVA
Runtime	An audible alarm sounds if the available runtime falls below this level (Hours:min).	0:0 (default), 5m, 10m, 15m, 30m, 45m, 1h, 2h, 3h, 4h, 5h, 6h, 7h, or 8h
Bypass	If the UPS fails and the input voltage or line frequency is outside of normal range, this option allows the user to choose Bypass mode, or drop the load.	Go to Bypass or Drop Load
Copy	Select the configuration that you wish to move UPS data into or out of, and then select the direction that you wish to move the data. <b>NOTE:</b> Copying data between different voltage versions may not yield optimum results. The output voltage selection should be reviewed by the user. Copying between different product lines may leave some parameters in the target UPS set to factory defaults, especially when copying from a product with lesser capability.	Options include: Configuration Number, from UPS to Display, and from Display to UPS.
Other	Remaining user-defined settings.	
Self Test	The UPS can automatically test itself at this user-specified interval.	At Power On, 7 days, 14 days (default), or Disabled
UPS ID	Assigns an eight-character text string to a system.	
Output	Sets output voltage. Selection depends upon system configuration.	US/JAPAN: 200 V, 208 V, 240 V INTERNATIONAL: 220 V, 230 V, 240 V
Vout Reporting	Reports the most significant output voltage.	Auto

## Troubleshooting

The PowerView reports various messages on the display, including alarm status and changes in system configuration. This section lists all the PowerView display messages, the reason for the message, and the appropriate corrective action.

Contact Schneider Electric Technical Support Staff for assistance with complex UPS problems. Refer to the Schneider Electric web site at <http://www.se.com> for a location near you.

Messages may occur simultaneously. If this happens, be sure to review all of the messages for a better understanding of the system condition..

Condition	PowerView Message	Reason	Corrective Action
Start-Up	#Pwr modules changed since last ON.	At least one power module has been added or removed from the UPS since the last time the Pwr ON command was issued.	No corrective action necessary. Proceed with the start-up.
	#Batteries changed since last ON.	At least one battery module has been added or removed from the UPS since the last time the Pwr ON command was issued.	
	No Redundant Intelligence Module (IM).	There is no redundant intelligence module installed and working.	Proceed with the start-up or abort the start-up and install a new IM. <b>NOTE:</b> Without two functioning IMs, there is no redundancy in the event of an IM failure.
	Batt capacity less than Return Batt Cap.	The battery capacity of the UPS is less than the user-specified minimum battery capacity required to turn on the load.	Option 1: Abort the start-up and allow batteries to recharge. Option 2: Continue start-up, with less than minimum battery capacity.
	Input Freq outside configured range.	The input frequency to the UPS is outside the configured range. The output frequency will not synchronize with the input frequency. Normal bypass is not available. The system will start on-battery.	Option 1: Improve the frequency of the incoming voltage. Option 2: Widen the range of the acceptable incoming frequency with the PowerView. (Startup>Setup>OutputFreq) Option 3: Proceed with start-up. Normal bypass is not available and system may start on battery power.
	AC adequate for UPS but not for bypass.	The UPS will function on-line with the input voltage. But, in the event that bypass is required, the input voltage is not adequate to power the load equipment.	Option 1: Improve the incoming voltage. Option 2: Proceed with start up. Normal bypass is not available.
	Low/No AC input, start-up on battery.	Input voltage is not adequate to start the UPS. If start-up continues, the UPS will function from battery.	Option 1: Abort start-up until acceptable input voltage is present. Option 2: Proceed with start up. Battery will be discharged.

Condition	PowerView Message	Reason	Corrective Action
<b>General Status</b>	# of batteries increased.	At least one battery module has been added to the system.	No corrective action is necessary.
	# of batteries decreased.	At least one battery has been removed from the system.	
	# of Pwr Modules increased.	At least one power module has been added to the system.	
	Intelligence Module inserted.	An intelligence module has been installed in the lower IM slot.	
	Intelligence Module removed.	An intelligence module has been removed from the lower IM slot	
	Redundant Intelligence Module inserted.	An intelligence module has been installed in the upper IM slot.	
	Redundant Intelligence Module removed.	An intelligence module has been removed from the upper IM slot.	
	# of External Battery Cabinets increased.	At least one external battery cabinet has been connected to the frame.	
	# of External Battery Cabinets decreased.	At least one external battery cabinet has been disconnected from the UPS.	
	Redundancy Restored.	Power module redundancy loss occurred and was restored. Either additional modules have been installed or the load has been reduced.	
	Redundancy Restored.	Power module redundancy loss occurred and was restored. Additional modules have been installed or the load has been reduced.	
	Load is No Longer above Alarm Threshold.	The load exceeded the load alarm threshold. The situation has been corrected by a load decrease or threshold increase.	
	Min Runtime restored.	The system runtime dropped below the configured minimum runtime and was restored. Additional battery modules were installed, the existing battery modules were recharged, the load was reduced, or the threshold was raised.	

Condition	PowerView Message	Reason	Corrective Action
<b>Module Failure</b>	Bad Battery Module.	A battery module has failed and requires replacement.	Refer to module installation in the <b>Symmetra LX Physical Installation Guide</b> .
	Bad Power Module.	A power module has failed and requires replacement.	
	Intelligence Module is installed and failed.	The intelligence module in the lower IM slot has failed.	
	Redundant Intelligence Module is installed and failed.	The intelligence module in the upper IM slot has failed.	
<b>Threshold Alarm</b>	Load is above kVA alarm threshold.	The load has exceeded the user-specified load alarm threshold.	Option 1: Reduce the load. Option 2: Use the PowerView interface to raise the alarm threshold.
	Redundancy has been lost.	The UPS no longer detects redundant power modules. The power module(s) failed or the load increased.	Option 1: If possible, install additional power modules. Option 2: Decrease the load. Option 3: Disable the redundancy alarm by setting redundancy to zero. (Startup > Setup > Alarms > Redundancy > Zero)
	Redundancy is below alarm threshold.	Actual power module redundancy has fallen below the user-specified redundancy alarm threshold. The power module(s) failed or the load has increased.	Option 1: If possible, install additional power modules. Option 2: Decrease the load. Option 3: Use the PowerView to decrease the redundancy alarm threshold. (Startup > Setup > Alarms > Redundancy)
	Runtime is below alarm threshold.	The predicted runtime is lower than the user-specified for the minimum runtime alarm threshold. The battery capacity has decreased or the load has increased.	Option 1: Allow the battery modules to recharge. Option 2: If possible, increase the number of battery modules. Option 3: Decrease the load. Option 4: Use the PowerView to decrease the minimum runtime alarm threshold. (Startup > Setup > Alarms > Runtime)

Condition	PowerView Message	Reason	Corrective Action
<b>Bypass</b>	Bypass is not in range (either freq or voltage).	The frequency and/or voltage are out of acceptable range for bypass. This message occurs when the UPS is online and the bypass mode is unavailable. The system may start on-battery.	Option 1: Decrease the sensitivity to input frequency. (Startup>Setup>OutputFreq) Option 2: Correct input voltage to provide acceptable voltage and/or frequency.
	Bypass contactor stuck in bypass position.	The UPS is positioned in the bypass position and cannot go on-line.	Call your contract service provider or Schneider Electric Technical Support.
	Bypass contactor stuck in on-line position.	The UPS is positioned in the on-line position and cannot go to bypass.	
	UPS has detected an internal fault and is in bypass mode.	The UPS has transferred to bypass mode because an internal fault has been detected.	
	UPS in bypass due to overload.	The load exceeded the system power capacity. The UPS has switched to bypass mode.	Option 1: Decrease the load. Option 2: If possible, add power modules to the system.
	System is in Maintenance Bypass.	The UPS is in bypass because the maintenance bypass switch is in the on position.	No corrective action necessary.
<b>General Fault</b>	On Battery.	The UPS is in the on-battery mode. The battery modules are being discharged.	No corrective action is necessary. <b>NOTE:</b> The runtime duration is limited. Prepare to shutdown the UPS and the load equipment, or restore incoming voltage.
	Need Bat Replacement.	One or more battery modules are in need of replacement.	Refer to module replacement procedure.
	UPS Fault.	An internal fault has been detected in a power module. The UPS Fault message always occurs when there is a bad power module failure message.	Call your contract service provider or Schneider Electric Technical Support.
	Shutdown or unable to transfer to Batt due to overload.	The UPS has shutdown because an overload occurred and bypass is not available.	Option 1: Reduce the load to eliminate overload. Option 2: If possible, add power modules to eliminate overload. Option 3: Replace failed power modules to eliminate overload. <b>NOTE:</b> If bypass is not available because of a power failure, wait for power to be restored. If there is a utility problem, have it corrected.

Condition	PowerView Message	Reason	Corrective Action
<b>General Fault (Continued)</b>	Load Shutdown from Bypass. Input Freq/ Volts outside limits.	The UPS shut the load down while it was on bypass due to the input power going out of the acceptable range.	Correct the input voltage problem.
	Fault, Battery Charger Failure.	The battery charger in one or more power module(s) failed.	Refer to module replacement procedure.
	Fault, Bypass Relay Malfunction.	The bypass relay has malfunctioned.	Call your contract service provider or Schneider Electric Technical Support.
	Fault, Internal Temp exceeded normal limits.	The temperature of one or more battery modules is too hot.	Replace the overheated module. Refer to module replacement procedure.
	Input circuit breaker tripped open.	The input circuit breaker on the UPS tripped open. Input voltage is disconnected from the UPS.	Option 1: If this occurs in conjunction with an overload condition, decrease the load and reset the breaker. Option 2: If no overload condition exists, reset the breaker. If the breaker trips open again, call contract service provider or Schneider Electric Technical Support.
	System level fan failed.	A cooling fan in the UPS frame failed.	Call contract service provider or Schneider Electric Technical Support.
	The Redundant Intelligence Module (IM) is in control.	The intelligence module in the lower IM slot has failed or is not installed. The intelligence module in the upper IM slot is managing all activity.	Replace the intelligence module. Refer to module replacement procedure.
	IIC inter-module communications failed.	The communications between the MIM and at least one other module failed.	Call contract service provider or Schneider Electric Technical Support.

## Service

**If the unit requires service, do not return it to the dealer. Follow these steps:**

- 1 Review the *Troubleshooting section* of the manual to eliminate common problems.
- 2 If the problem persists, contact Schneider Electric Customer Support through the Web site, [www.se.com](http://www.se.com).
  - a. Note the model number and serial number and the date of purchase. The model and serial numbers are located on the rear panel of the unit and are available through the display interface on select models.
  - b. Call Schneider Electric Customer Support and a technician will attempt to solve the problem over the phone. If this is not possible, the technician will issue a Returned Material Authorization Number (RMA#).
  - c. If the unit is under warranty, the repairs are free.
  - d. Service procedures and returns may vary internationally. Refer to Schneider Electric Web site for country specific instructions.
- 3 Pack the unit in the original packaging whenever possible to avoid damage in transit. Never use foam beads for packaging. Damage sustained in transit is not covered under warranty.
  - a. **Always DISCONNECT THE UPS BATTERIES before shipping. The International Air Transport Association (IATA) regulations require that UPS batteries be disconnected before shipping.** The internal batteries may remain in the UPS but need to be disconnected.
- 4 Write the RMA# provided by Customer Support on the outside of the package.
- 5 Return the unit by insured, prepaid carrier to the address provided by Customer Support.

## Battery Replacements Kits and Battery Recycling

See your dealer or visit the Schneider Electric web site at <http://www.se.com> for information on battery replacement kits and battery recycling. If returning used batteries to Schneider Electric for recycling, ship used batteries in the battery replacement packing material.

## Worldwide Customer Support

Customer support for this or any other APC product is available at no charge in any of the following ways:

- Visit the our web site to access documents in the APC Knowledge Base and to submit customer support requests.
  - [www.se.com](http://www.se.com) (Corporate Headquarters)
- Connect to localized APC web site for specific countries, each of which provides customer support information.
  - [www.se.com/support/](http://www.se.com/support/)
- Global support searching APC Knowledge Base and using e-support.
- Contact APC Customer Support Center by telephone or e-mail.
  - Local, country specific centers: go to [www.se.com/contact](http://www.se.com/contact) for contact information.
  - For information on how to obtain local customer support, contact our representative or the distributor from whom you purchased your APC product.



Schneider Electric

35 rue Joseph Monier  
92500 Rueil Malmaison - France  
Phone: +33 (0) 1 41 29 70 00  
[www.se.com](http://www.se.com)

As standards, specifications, and designs change from time to time,  
please ask for confirmation of the information given in this publication.

© 2025 Schneider Electric. All Rights Reserved.

EN 990-1546C