

APC® NetShelter®

Extension Kit—AR8130

Overview

Use this kit to mount an American Power Conversion (APC) extension frame onto an APC NetShelter enclosure.

Inventory

Item	APC Part #	Qty
Extension frame	OM-6047	1
M6 × 12 socket head cap screws	803-0012A	6
M6 door bumpers	827-0044	2
Hinge pin cover	OM-6077A	2
Latch bracket	870-8449B	1
Hinge Pin Bushings	827-0014	2

Tools Required

- Phillips screwdriver
- Allen wrench (5 mm)
- 10 mm open-ended wrench

If you are missing a part, contact the APC representative or other distributor from whom you purchased your APC product, or contact an APC Customer Support center by telephone or e-mail.

- Regional centers:

APC Headquarters (U.S. and Canada)	(1) (800) 800-4272 (toll free)
Latin America	(1) (401) 789-5735 (United States) apctchla@apcc.com
Europe, Middle East, Africa	(353) (91) 702020 (Ireland) apceurtech@apcc.com
Japan	(03) 5434-2021 jsupport@apcc.com

- Local, country-specific centers: go to <http://www.apcc.com/support/contact> for contact information.

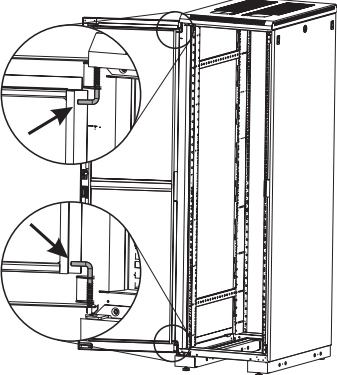
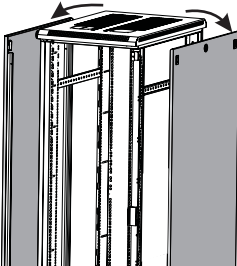
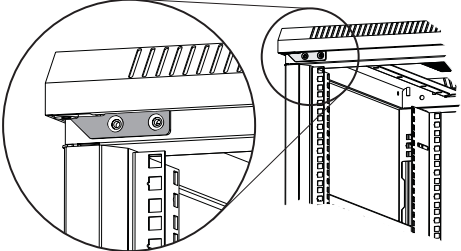
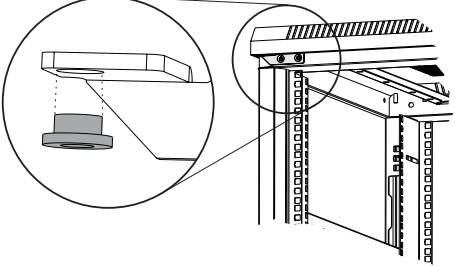
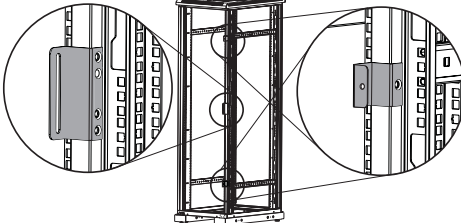

Mounting Instructions

Step	Action	Figure
1	Remove the rear door of the enclosure using the two retractable hinge pins.	
2	Remove both side panels if attached.	
3	Remove the hinge brackets mounted with two M6 flat head screws from the top and bottom of the enclosure. Save the four flat head screws to use in steps 10 and 11.	
4	Remove the bushing from the mounting hole on the hinge plate to be used in step 10.	
5	Remove the bumper brackets from the top and bottom of the corner post using a Phillips head screwdriver and a 10 mm open end wrench. Remove the latch bracket from the corner post.	

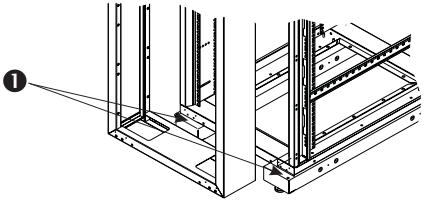
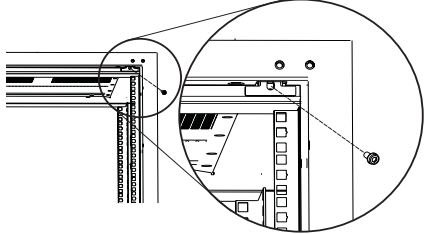
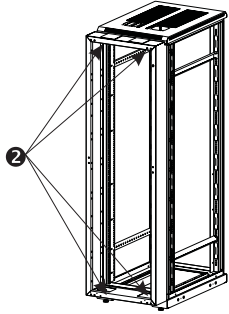
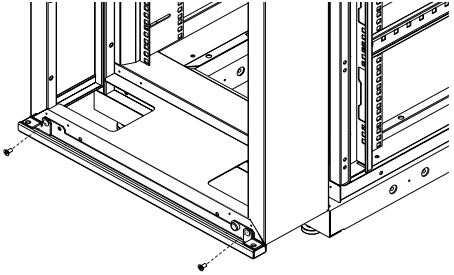
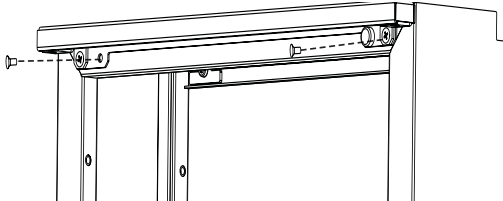
Step	Action	Figure
6	Rest the extension frame upon the plinths ❶ of the enclosure. Center the extension frame, aligning the four inside mounting holes to those on the enclosure.	
7	Loosely attach the extension frame using an M6 socket head cap screw in one upper mounting hole.	
8	Loosely attach the remaining socket head cap screws in the remaining upper and lower mounting holes ❷.	
9	Tighten all four M6 socket head cap screws using the 5 mm Allen wrench.	
10	Attach the lower hinge pin cover to the extension frame using two of the M6 flat head screws from Step 3 in the countersunk mounting holes.	
11	Attach the upper hinge pin cover using two M6 flat head screws from Step 3 in the countersunk mounting holes.	

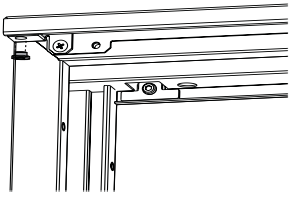
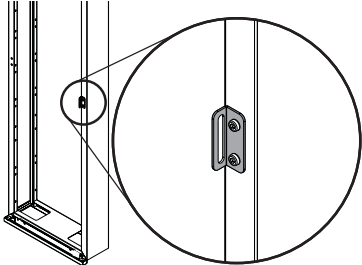
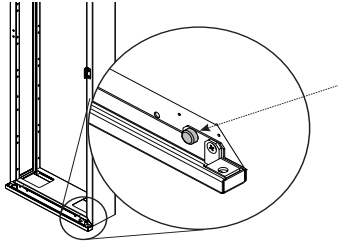
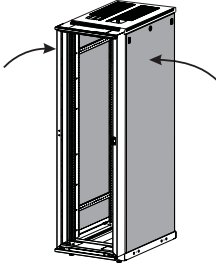
Step	Action	Figure
12	Insert the bushings from step 4 into the hinge holes.	
13	Attach the new latch bracket using two M6 socket head cap screws.	
14	Attach the two new M6 door bumpers ③ to the remaining mounting holes at the upper and lower latch side of the extension frame.	
15	Reattach the side panels if required.	
16	Reattach the rear door.	