

Technical Specifications

InRow[®] Air-cooled, Self-contained Air Conditioners

InRow[®] SC

50/60 Hz



Schneider Electric IT Corporation Legal Disclaimer

The information presented in this manual is not warranted by the Schneider Electric IT Corporation to be authoritative, error free, or complete. This publication is not meant to be a substitute for a detailed operational and site specific development plan. Therefore, Schneider Electric IT Corporation assumes no liability for damages, violations of codes, improper installation, system failures, or any other problems that could arise based on the use of this Publication.

The information contained in this Publication is provided as is and has been prepared solely for the purpose of evaluating data center design and construction. This Publication has been compiled in good faith by Schneider Electric IT Corporation. However, no representation is made or warranty given, either express or implied, as to the completeness or accuracy of the information this Publication contains.

IN NO EVENT SHALL SCHNEIDER ELECTRIC IT CORPORATION, OR ANY PARENT, AFFILIATE OR SUBSIDIARY COMPANY OF SCHNEIDER ELECTRIC IT CORPORATION OR THEIR RESPECTIVE OFFICERS, DIRECTORS, OR EMPLOYEES BE LIABLE FOR ANY DIRECT, INDIRECT, CONSEQUENTIAL, PUNITIVE, SPECIAL, OR INCIDENTAL DAMAGES (INCLUDING, WITHOUT LIMITATION, DAMAGES FOR LOSS OF BUSINESS, CONTRACT, REVENUE, DATA, INFORMATION, OR BUSINESS INTERRUPTION) RESULTING FROM, ARISING OUT, OR IN CONNECTION WITH THE USE OF, OR INABILITY TO USE THIS PUBLICATION OR THE CONTENT, EVEN IF SCHNEIDER ELECTRIC IT CORPORATION HAS BEEN EXPRESSLY ADVISED OF THE POSSIBILITY OF SUCH DAMAGES. SCHNEIDER ELECTRIC IT CORPORATION RESERVES THE RIGHT TO MAKE CHANGES OR UPDATES WITH RESPECT TO OR IN THE CONTENT OF THE PUBLICATION OR THE FORMAT THEREOF AT ANY TIME WITHOUT NOTICE.

Copyright, intellectual, and all other proprietary rights in the content (including but not limited to software, audio, video, text, and photographs) rests with Schneider Electric IT Corporation or its licensors. All rights in the content not expressly granted herein are reserved. No rights of any kind are licensed or assigned or shall otherwise pass to persons accessing this information.

This Publication shall not be for resale in whole or in part.

Table of Contents

Technical Data..... 1

Features and Options 1

Capacity	1
Configuration	1
Compliance approval	1
Standard features	2
Accessories	2
Self-contained system	3

Standard Features 4

Cabinet	4
Insulated side panels	4
Variable speed fans	4
Condensate pump	4
Condensate pan	4
Electronic hot gas bypass	4
Single cord power supply	4
Network management card	4
High head pressure protection	5
Rack inlet temperature control	5
Remote shutdown/IO contacts	5
Dual fan power supply	5
Washable filters	5
Condenser ducting kit	5
Active response control	5

Microprocessor Controller 6

Open architecture	6
Control Type	6
Control	6
Functions	6
Logging	6
Factory default setpoints	7
Alarms	7

Component Identification 8

External components	8
Internal components	9

Performance Specifications 10

Net Cooling Capacity	10
----------------------	----

General Specifications 11

General data	11
Altitude correction factors	12
Sound performance data	12

Electrical Data 13

Dimensional Data.....14

Dimensions and Weight 14

 Service access 15

Piping and Mechanical Connections 16

Guide Specifications17

Guide Specifications for the InRow SC 17

Technical Data

Features and Options

The InRow™ SC offers efficient, effective, and economical cooling.

Critical environmental requirements now reach far beyond the confines of the traditional data center or computer room to encompass a larger suite of applications referred to as technology rooms. Critical environment applications include:

- Computer rooms
- Wiring Closets
- Telecommunication facilities
- Clean rooms
- Power equipment
- Medical equipment rooms
- Archives
- LAN/WAN environments

A worldwide network of Schneider Electric representatives is fully qualified to provide engineering, sales, installation, and service for our products. Schneider Electric warrants all parts for 12 months from commissioning or 18 months from the shipping date (whichever occurs first). Parts and labor are warranted if factory start-up is conducted. Extended warranties are available.

Capacity

The InRow® SC self-contained configuration is available in a nominal capacity of 5 kW with extended capacity of up to 7 kW when used in conjunction with RACS (Rack Air Containment System) or elevated return temperatures.

Configuration

Self-contained air-cooled.

NOTE: This unit must be used with a RACS.

Compliance approval

- UL Listed
- C-UL Listed
- CE
- IEC
- BSMI
- EN 55022 Class A
- FCC Part 15 Class A
- ICES-003
- VCCI
- VDE

Standard features

- Insulated side panels
- Variable speed direct drive tubeaxial fans
- Remote temperature sensor
- Microprocessor controller
- Washable filter
- Evaporator coil
- Condenser coil
- Compressor
- Condensate pump
- Condensate pan
- Electronic hot gas bypass valve
- Single cord power supply
- Network management card
- High head pressure protection
- Rack inlet temperature control
- Dual fan power supply
- Input/output contacts - alarms
- Condenser ducting kit
- SX rack joining kit
- Remote shutdown

Accessories

- Rope water detector
- Cable support bridge trough
- VX rack joining kit

Self-contained system

An air-cooled self-contained system has all the refrigerant system components located in a single enclosure. The unit is pre-charged from the factory and requires no field-installed refrigerant lines or remote heat exchangers. Heat is rejected to a building return plenum via the ducting kit designed to connect to a standard drop ceiling.

- No specialized skills or trade required for installation
- Factory sealed and tested system
- Rapidly deployable
- Low maintenance

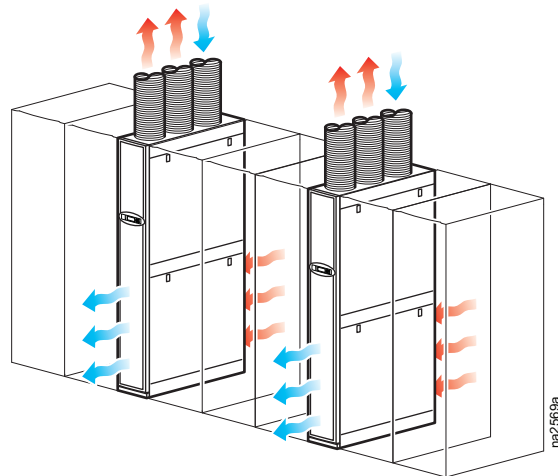

Standard Features

Cabinet

The frame is constructed of 16-gauge formed steel for maximum strength. The cabinet is serviceable from the front and rear. All exterior panels and corner posts on the frame are powder coated for durability and an attractive finish.

Front and rear exterior panels are constructed of 18 gauge perforated steel with 69.5% open free area.

Insulated side panels

Insulation is 80.1 kg/m³ (5 lb/ft³) density and complies with ASTM E84 rating of 25/50. All panels include a key latch for safety and security, allowing easy access and removal.

Variable speed fans

Each unit is equipped with six 200-mm mixed flow, direct drive, tubeaxial DC fans. Three of the fans blow air across the condenser coil to provide heat rejection from the refrigerant system. In order to provide uniform airflow across the evaporator coil, the remaining three fans draw air through the evaporator section. The evaporator fans can be easily replaced while the unit is in operation. All fans are variable speed, allowing them to assist in modulating unit cooling capacity and maintaining refrigerant head pressure.

Condensate pump

Removes condensate from the system to ensure continuous operation. The factory installed and wired condensate pump is capable of pumping 1.3 g/hr (5.9 l/hr) against head pressures of up to 50 ft (15.2 m) of total run: of that length, 16 ft (4.9 m) can be vertical lift.

Condensate pan

The condensate pan is fabricated from V-0 polymeric materials and is thermal formed, provided with anti-fungal additives, and is a nonferrous material for higher indoor air quality.

Electronic hot gas bypass

An electronically controlled hot gas bypass valve directs hot discharge gas from the compressor back to the expansion valve and into the coil. During lightly loaded conditions, compressor cycling is reduced and prevents the evaporator coil from freezing. Hot gas bypass also assists in the management of the refrigerant head pressure.

Single cord power supply

The 60 Hz unit utilize a NEMA L6-20 plug, the 50 Hz unit uses an IEC 309 16A plug. The power cord can be connected to the power feed either through the top or bottom of the unit.

Network management card

Permits multi-level access to monitoring, control, and event notification features over the local network.

High head pressure protection

The condenser fans modulate to maintain a nominal refrigerant discharge of 425 psig (6.9 kPa). If the condenser inlet air is restricted or too warm, the refrigerant discharge pressure will rise forcing the condenser fans to increase speed to 100%. To prevent a total loss of cooling, the unit will slow evaporator fans and begin to activate the hot gas bypass valve to reduce system capacity. If the discharge pressure continues to rise, the unit will shut down in order to prevent unit damage.

Rack inlet temperature control

To control the unit based on rack inlet temperature, a remote sensor is provided. This sensor is factory wired for a remote placement in the field on adjacent IT racks.

Remote shutdown/I/O contacts

The unit provides one field connection input for remote shutdown. I/O contacts allow for remote annunciation of any alarm condition or critical only alarms.

Dual fan power supply

The unit includes two (2) power supplies, each capable of running all fans at 80% capacity in the event of a single power supply failure. Individual power supplies are hot swappable.

Washable filters

The filtration of conditioned air is extremely vital to maintaining the clean, particle-free environment required by electrical equipment. Filters are <20% efficient (ASHSCE 52.1) and MERV 1 (ASHRAE 52.2) rated that meets HF-1 standards for electronics.

Condenser ducting kit

Sixty (60) Hz units have a 24 in. x 24 in. adapter; 50 Hz units have a 600 mm x 600 mm adapter. Each duct tube is 6 ft (1.8 m) long and 10 in. (254 mm) in diameter. Three ducts are provided, one for the condenser supply and two for the condenser exhaust. Mounting hardware is provided to attach ducts to the ceiling adapter.

Active response control

The active response control monitors rack inlets and controls cooling capacity to match the IT heat load. Included is a user-friendly interface for ease of operation.

Microprocessor Controller

The microprocessor controller is standard on each system.

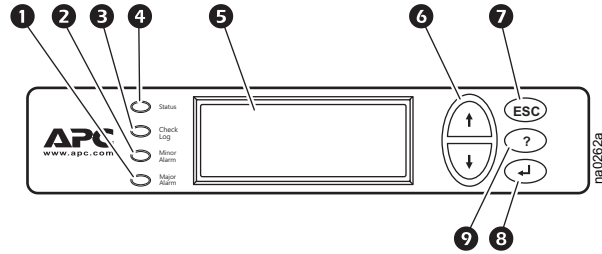

Item	Description	Item	Description
1	Critical alarm LED	6	Up and down arrow keys
2	Warning alarm LED	7	ESC key
3	Check log LED	8	Enter key
4	Status LED	9	Help key
5	Liquid crystal display (LCD)		

Open architecture

The InRow SC protocol is open for integration with all building management systems. Communication interface on the system is MODBUS RS485.

Control Type

Controller utilizes proportional and integral derivative (PID). The PID is nonadjustable, and can not be customer configured.

Control

The backlit, four-line by twenty character display is password configurable.

Functions

- Supply and return air temperatures
- Operational mode control
- Event logging
- Alarms
- Fan speed adjustment
- Input/output module programming
- Refrigerant discharge and suction pressure
- Suction line temperature

Logging

The microprocessor displays the 30 most recent alarms. Each alarm log contains a time/date stamp as well as operating conditions at the time of occurrence. The controller also displays run time, in hours, for major components (Air Filter, Condenser Fans, Evaporator Fans, Compressor, Condensate Pump, Fan Power Supplies).

Factory default setpoints

- Cool: 72.0°F (22.2°C)
- Deadband: 1.8°F (1.0°C)
- Supply Air InRow: 64.0°F (17.8°C)
- Supply Air RACS: 64.0°F (17.8°C)
- Supply Air Spot: 57.0°F (13.9°C)

Alarms

- Air filter clogged
- Air filter run hours violation
- Condensate pump full fault
- Condenser fan #n fault
- Cooling failure
- Persistent high/low discharge suction pressure alarm
- Rack inlet high temperature violation/fault
- Suction pressure sensor temperature fault
- Supply air high temperature violation
- Upper return/supply air sensor fault
- Discharge pressure sensor fault
- Evaporator fan #n fault
- External communication fault
- Fan power supply left/right fault
- High discharge pressure alarm
- Internal communication fault
- Lower return/supply air sensor fault
- Low suction pressure alarm
- On standby: input contact fault
- Water detection fault

Component Identification

External components

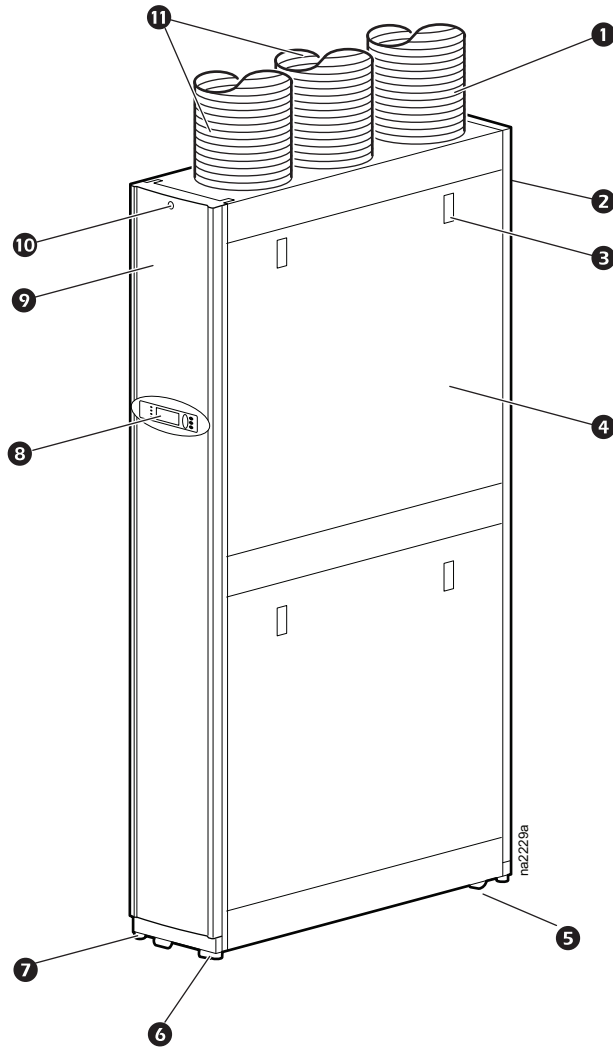

Item	Description	Item	Description
1	Intake air duct	7	Adjustable leveling foot (four places)
2	Removable rear door	8	Display interface
3	Side panel latch/lock	9	Removable front door
4	Removable side panel	10	Door lock
5	Rear casters (non-swiveling)	11	Exhaust air duct
6	Front casters (swiveling)		

Internal components

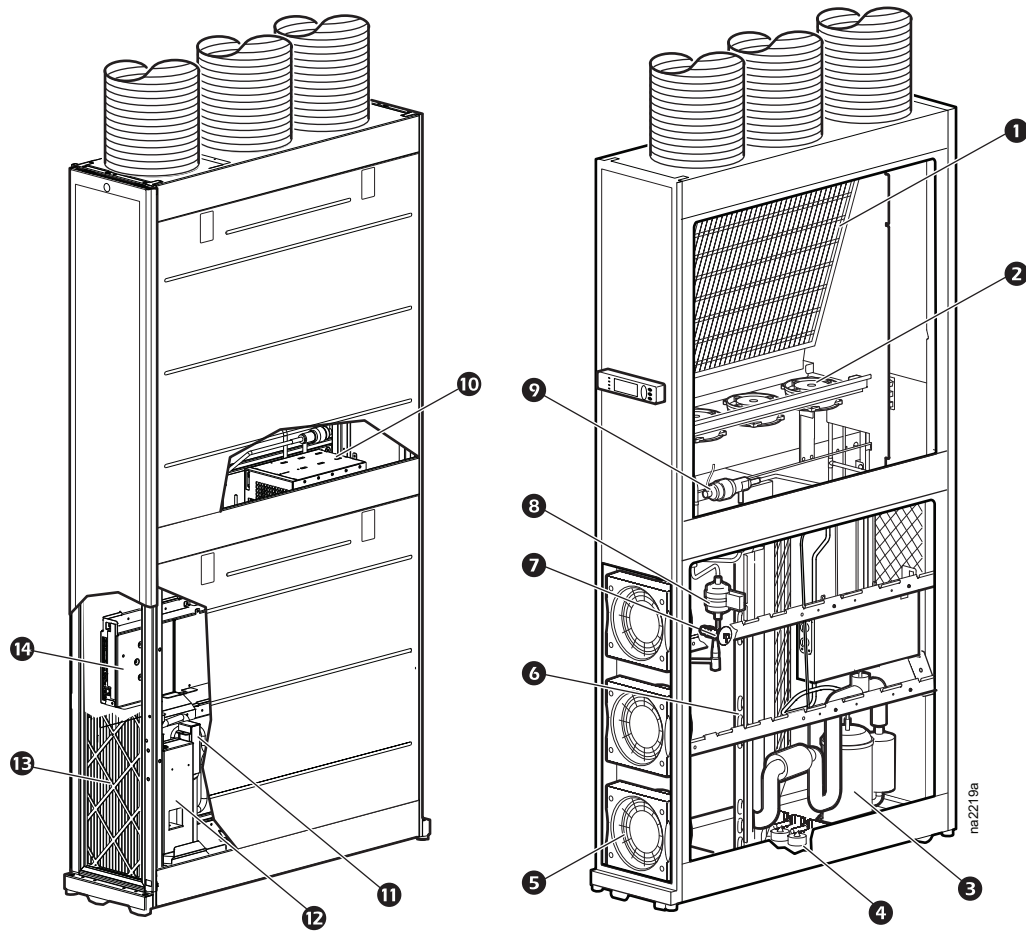

NOTE: Some parts, frame, and side structure have been removed from this illustration for clarity.

Item	Description
1	Condenser coil
2	Condenser fans
3	Compressor
4	Condensate pan floats
5	Evaporator fans
6	Evaporator coil
7	Thermostatic expansion valve
8	Refrigeration filter drier
9	Hot gas bypass valve
10	Power supply
11	Condensate pump
12	High voltage box
13	Washable 1/2-in. air filter
14	User interface box

Performance Specifications

Net Cooling Capacity

Model	ACSC100 Series	ACSC101 Series
Electrical Input	208 – 230 V, 1 ph, 60 Hz	200 – 240 V, 1 ph, 50 Hz
70°F DB, 58.5°F WB (21.1°C DB, 14.7°C WB)		
Total - BTU/hr (Watts)	16300 (4770)	15100 (4410)
Sensible - BTU/hr (Watts)	15100 (4440)	14300 (4200)
72°F DB, 60.0°F WB (22.2°C DB, 15.6°C WB)		
Total - BTU/hr (Watts)	17000 (4980)	15400 (4510)
Sensible - BTU/hr (Watts)	15500 (4530)	14400 (4230)
75°F DB, 61.0°F WB (23.9°C DB, 16.1°C WB)		
Total - BTU/hr (Watts)	16700 (4890)	16200 (4740)
Sensible - BTU/hr (Watts)	16200 (4740)	15900 (4650)
80°F DB, 67.0°F WB (26.7°C DB, 19.4°C WB)		
Total - BTU/hr (Watts)	18100 (5310)	18000 (5250)
Sensible - BTU/hr (Watts)	15500 (4560)	16000 (4680)
80°F DB, 62.5°F WB (26.7°C DB, 16.9°C WB)		
Total - BTU/hr (Watts)	17200 (5040)	16700 (4890)
Sensible - BTU/hr (Watts)	17200 (5040)	16700 (4890)
85°F DB, 65.0°F WB (29.4°C DB, 18.3°C WB)*		
Total - BTU/hr (Watts)	18000 (5250)	16700 (4890)
Sensible - BTU/hr (Watts)	18000 (5250)	16700 (4890)
95°F DB, 82.7°F WB (35.0°C DB, 28.2°C WB)**		
Total - BTU/hr (Watts)	22000 (6450)	21300 (6240)
Sensible - BTU/hr (Watts)	11300 (3300)	11300 (3300)
96°F DB, 68°F WB (35.5°C DB, 20°C WB)***		
Total - BTU/hr (Watts)	22200 (6500)	19800 (5800)
Sensible - BTU/hr (Watts)	22200 (6500)	19800 (5800)

NOTE: All values are accurate to +/- 5% and based on full fan speed with standard filters and 95°F (35°C) Condenser entering air.

All tests were performed at 100% evaporator fan speed except as noted. Net cooling data is published above.

*Airflow reduced to 1000 CFM (1700 m3/hr) at this condition to maintain appropriate suction temperature.

**Airflow reduced to 600 CFM (1020 m3/hr) at this condition to maintain appropriate suction temperature.

***Airflow reduced to 850 CFM (1440 m3/hr) to maintain appropriate suction temperature. Represents conditions with front and rear containment.

General Specifications

General data

MODEL	ACSC100 Series	ACSC101 Series
ELECTRICAL INPUT	208 – 230 V, 1 ph, 60 Hz	200 – 240 V, 1 ph, 50 Hz
AIR SYSTEM - Direct Drive Tubeaxial Fans*		
Maximum Evaporator Airflow - CFM (m ³ /hr)	1200 (2038)	
Minimum Evaporator Airflow - CFM (m ³ /hr)	400 (679)	
Maximum Condenser Airflow - CFM (m ³ /hr)	850 (1440)	
Minimum Condenser Airflow - CFM (m ³ /hr)	300 (509)	
REFRIGERANT		
R410A - oz (kg)	52 (1.47)	
Maximum Total Heat of Rejection BTU/hr (Watts)	34000 (10000)	29700 (8700)
EVAPORATOR COIL - COPPER TUBE/ALUMINUM FIN		
Face Area - ft ² (m ²)	2.5 (0.23)	
Rows Deep	2	
Face Velocity - FPM (m/s)	380 (2.44)	
FILTERS		
Quantity	1	
Size - in. (mm)	9.375 X 36.75 (238 X 933)	
Depth - in. (mm)	1/2 (13)	
Efficiency- ASHRAE 52.1 (ASHRAE 52.2)	<20% (MERV 1)	
PHYSICAL DATA - UNIT		
Weight - lbs (kg)	365 (165.9)	
Height - in. (mm)	78.4 (1991)	
Width - in. (mm)	11.8 (300)	
Depth - in. (mm)	42.1 (1069)	
PHYSICAL DATA - CONDENSER DUCT TUBES		
Length - ft (m)	6 (1.8)	
Diameter - in. (mm)	10 (254)	
CONNECTION SIZES - CONDENSATE DRAIN		
Drain Line ID - in. (mm)	3/16 (4.76)	



Altitude correction factors

Altitude – ft	0	1000	2000	3000	4000	5000	6000	7000	8000	9000	10000
Specific Volume – ft³/lb	13.58	14.09	14.62	15.18	15.76	16.36	17.00	17.67	18.37	19.11	19.89
Density – lb/ft³	0.074	0.071	0.068	0.066	0.063	0.061	0.059	0.057	0.054	0.052	0.050
Density Ratio	1.000	0.964	0.929	0.895	0.862	0.830	0.799	0.769	0.739	0.711	0.683
Capacity Correction	1.000	0.981	0.962	0.933	0.913	0.884	0.865	0.846	0.826	0.807	0.787
NOTE: Room condition: 72°F db/50% RH NOTE: Density ratio is used for air flow correction factor. NOTE: Capacity correction is used to de-rate performance.											

Sound performance data

Air-Cooled Tested Sound Data										
Fan Speed%	Evaporator Air-flow Rate (SCFM)	Octave Band Hz, Sound Power dB re 10 ⁻¹² Watts. Data Obtained from Reverberation Sound Tests in Accordance with ANSI S12.51-2202, ISO 3741-1999							Sound Power (dBA)	Lp Sound Pressure dB re: 20 microPa*
		125	250	500	1000	2000	4000	8000		dBA
EvF 100% CondF 100%	1180	77.5	86.5	86.5	83.0	78.0	75.5	70.5	87.7	82.2
EvF 90% CondF 100%	1080	77.5	86.5	85.5	81.0	76.0	73.5	68.0	86.4	81.0
EvF 80% CondF 100%	960	82.0	86.5	85.5	79.5	75.5	70.5	65.5	85.7	80.5
EvF 60% CondF 80%	810	74.5	87.0	79.5	78.5	73.0	66.5	62.5	83.9	78.1
NOTE: Abbreviations EvF and CondF stand for evaporator fan and condenser fan respectively. *Weighted Sound Pressure dBA in a 10 ft x 10 ft x 10 ft room at 5 ft distance. Sound data verified by testing at NRTL.										

Electrical Data

SKU	Rated						In-Rush***			Plug Type
	Voltage (Volts)	Phase	Frequency (Hz)	Current* (Amps)	Power** (Watts)	Power Factor	Duration (ms)	Peak Current (Amps)	Power (Watts)	
ACSC100	208-230	1	60	16.0	2940	0.98	200	56.0	8240	
ACSC101	220-240	1	50	14.4	2390	0.98	60	65.0	10100	

NOTE: *Rated Current is the maximum current draw for the input voltage range.
 **Rated Power is maximum power consumption expected during normal operations, actual power draw may vary based upon operating conditions.
 ***In-Rush is of short duration and only occurs during start-up and compressor cycling.

Dimensional Data

Dimensions and Weight

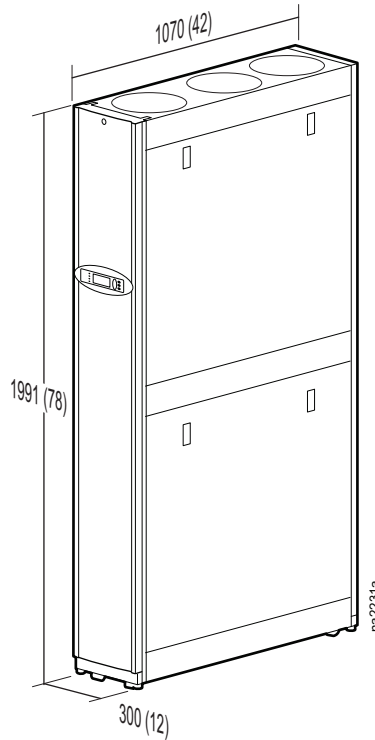

Dimensions are shown in mm (in.).

Model	Packed Weight	Unpacked Weight
ACSC100	475 lb (216 kg)	365 lb (166 kg)
ACSC101		

Service access

Routine service and basic repair activities can be accomplished with front and rear access only. Schneider Electric recommends 36 in. (914 mm) of clear floor space in front and back of the unit for this purpose. For major repair activities needing side access, 30 in. (762 mm) of clear space should be provided as needed.

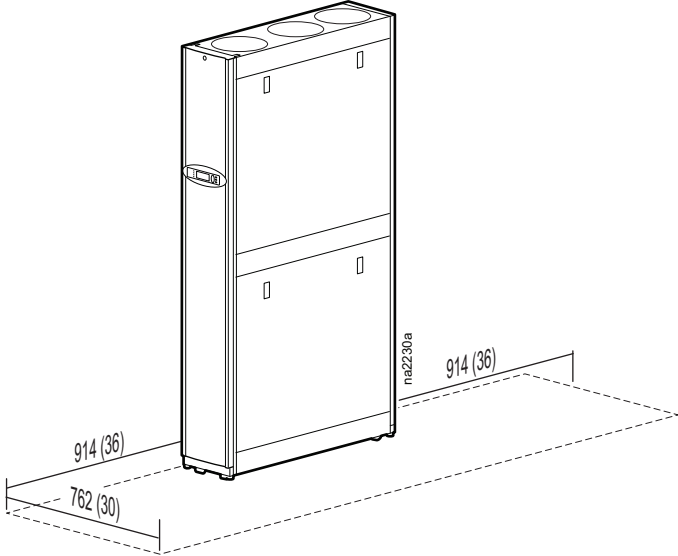

Dimensions are shown in mm (in.).

Piping and Mechanical Connections

TOP VIEW
EXTERNAL PIPING AND POWER FEED LOCATIONS

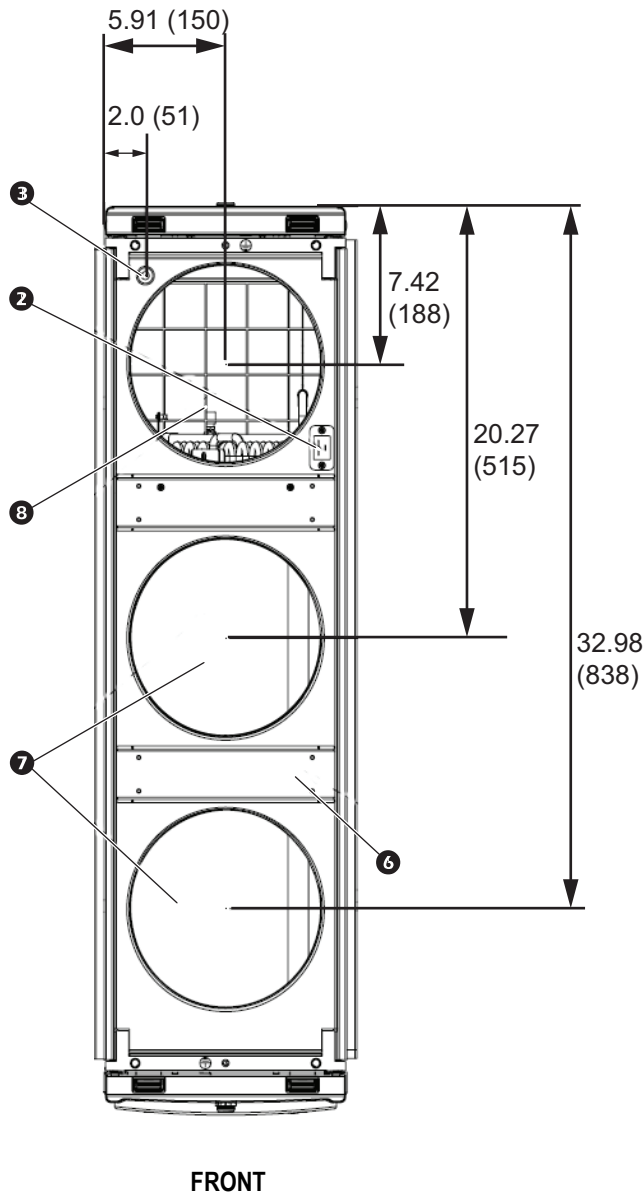

BOTTOM VIEW
EXTERNAL PIPING AND POWER FEED LOCATIONS

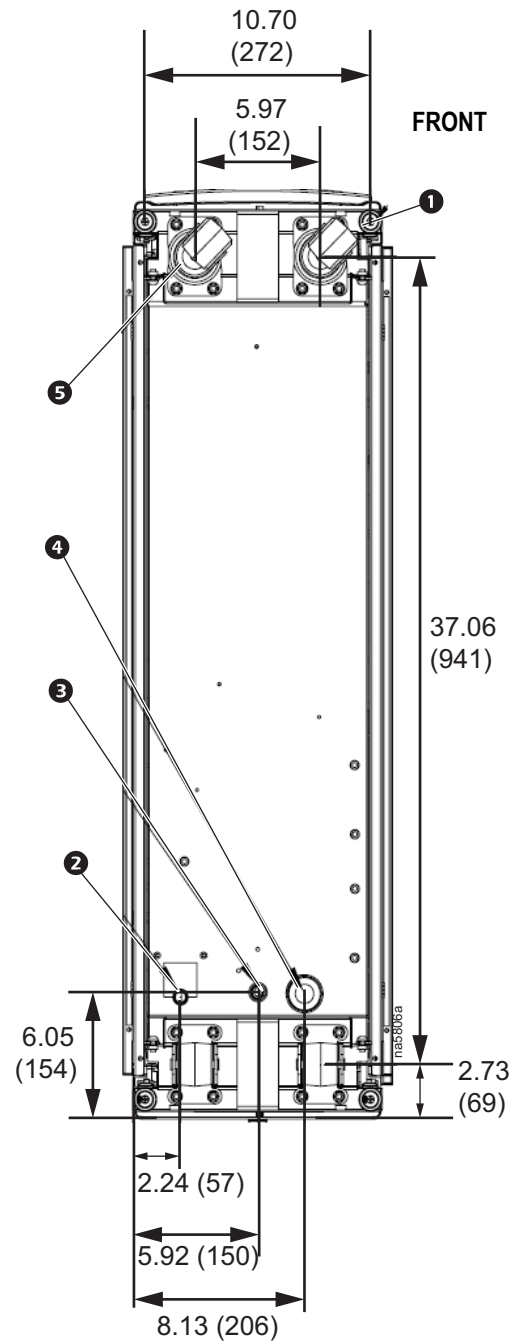

NOTE: Dimensions are shown in mm (in.). For more detailed information, please refer to submittal drawings.

Item	Description	Item	Description
1	Leveling feet (4)	5	Casters (4)
2	Electrical power connections	6	Cable trough
3	Condensate line – 0.25 in. (6.35 mm) ID; 0.38 in. (9.65 mm) OD	7	Exhaust air duct
4	Communication line inlet	8	Intake air duct

Guide Specifications

Guide Specifications for the InRow SC

PART 1 — STANDARD COMPONENTS

A. CABINET CONSTRUCTION

1. Exterior panels shall be 18 gauge metal with 5 lb/ft³ (80 kg/m³) density foam insulation. Insulation complies with UL94-5VA ASTM E84 flame spread and smoke developed rating of 25/50. Front and rear exterior panels shall be 18 gauge perforated steel with 69.5% open free area, and equipped with a keyed lock to provide a means of securing access to the internal components of the unit.
2. The frame shall be constructed of 16 gauge formed steel welded for maximum strength. All units shall provide full service from the front and rear, allowing units to be placed within a row of racks.
3. All exterior panels and frame shall be powder coated for durability and attractive finish. Exterior frame and panel color shall have color values: L = 74.50, a = -.53, b = +8.20.
4. Units shall include casters and leveling feet to allow ease of installation in the row and provide a means to level the equipment with adjacent IT racks.

B. VARIABLE SPEED DIRECT DRIVE MIXED FLOW DC FAN ASSEMBLY

1. Fan: Each unit shall include six 200 mm mixed flow direct drive DC axial fans. Three fan assemblies shall be designed to provide 400 CFM (680 m³/hr) each across the evaporator coil for total unit airflow of 1200 CFM (2039 m³/hr). The evaporator fans are designed to provide a draw-through air pattern to the unit and maintain a uniform air flow over the entire face of the coil. Three fan assemblies shall be designed to provide 283 CFM (480 m³/hr) each across the condenser coil for total unit airflow of 850CFM (1440 m³/hr).The condenser fans blow air across the condenser coil to provide heat rejection from the refrigerant system.
2. Variable Speed Fans: Fans shall be variable speed capable of modulating from 30 – 100%. Fans shall soft start to minimize in-rush current when starting.
3. Fan Protection: Each fan assembly shall consist of a plastic injection molded bezel with integral fan discharge finger guard. Inlet of the fan should include a cage type finger guard.
4. Operation and Service: The unit should be capable of operation in the event of a fan failure. Fans shall be replaceable while the unit is in operation.

C. POWER SUPPLY

1. Input Power Feed: Single power input should be a locking NEMA or IEC plug connection suitable for the input power selected. Unit power consumption is not to exceed 2950 watts during normal operation.
2. Power Supplies: Dual power supplies are capable of running the unit fans at 80% capacity in the event of a power supply failure. Power supplies shall be hot-swappable

D. MICROPROCESSOR CONTROLLER

1. Monitoring and Configuration: The master display shall allow monitoring and configuration of the air conditioning unit through a menu-based control. Functions include status reporting, set-up, and temperature set points. Four LEDs report the operational status of the connected air conditioning unit.
2. Controls: The microprocessor controller shall come equipped with control keys to allow the user to navigate between menus, select items, and input alpha numeric information.
3. Alarms: The microprocessor controller shall activate a visible and audible alarm in the occurrence of the following events:
 - a. Air Containment Pressure Sensor Fault
 - b. Air Filter Clogged
 - c. Air Filter Run Hours Violation
 - d. Condensate Pan Full Fault
 - e. Condensate Pump Fault
 - f. Condenser Fan #n Fault
 - g. Cooling Failure
 - h. Discharge Pressure Sensor Fault
 - i. Evaporator Fan #n Fault
 - j. External Communication Fault
 - k. Fan Power Supply Left Fault
 - l. Fan Power Supply Right Fault
 - m. Filter Sensor Fault
 - n. High Discharge Pressure Alarm
 - o. Internal Communication Fault
 - p. Lower Return Air Sensor Fault
 - q. Lower Supply Air Sensor Fault
 - r. Low Suction Pressure Alarm
 - s. On Standby: Input Contact Fault
 - t. Persistent High Discharge Pressure Alarm
 - u. Persistent Low Suction Pressure Alarm
 - v. Rack Inlet High Temperature Violation
 - w. Rack Inlet Temperature Sensor Fault
 - x. Return Air High Temperature Violation
 - y. Suction Pressure Sensor Fault
 - z. Suction Temperature Sensor Fault
 - aa. Supply Air High Temperature Violation
 - ab. Upper Return Air Sensor Fault
 - ac. Upper Supply Air Sensor Fault
 - ad. Water Detection Fault
4. Logging: The microprocessor controller shall log and display all available events. Each alarm log shall contain time/date stamp as well as operating conditions at the time of occurrence. Controller shall display the run time hours for major components.

E. NETWORK MANAGEMENT CARD

The unit shall include a network management card to provide management through a computer network through TCP/IP. Management through the network should include the ability to change set points as well as view and clear alarms.

F. EVAPORATOR AND CONDENSER COIL

Coil shall use raised lance with rippled edge type aluminum fin and 0.375 in. OD rifled copper tube coils with 0.012 in. wall thickness. Coil end supports shall be a minimum 18 gauge galvanized steel.

- G. **CONDENSATE PAN**
Drain pan shall include a condensate pump and dual floats for control and overflow protection. Condensate pans are V-0 thermal formed, anti-fungal, non-ferrous material for higher indoor air quality.
- H. **CONDENSATE PUMP**
Factory Installed and wired condensate pump shall pump 1.3 gal/h (4.9 liters/hour) at 16 ft (4.9 m) of vertical lift and a 50 ft (15.2 m) horizontal run.
- I. **FILTERS**
Standard Air filter: <20% efficient per ASHRAE 52.1, MERV 1 per ASHRAE 52.2, 1/2 in. washable mesh filter.
- J. **REMOTE TEMPERATURE SENSOR**
Remote temperature sensor shall ship factory wired to the unit for placement in the field to provide control input based on rack inlet temperature.
- K. **HOT GAS BYPASS**
The unit shall use an electronic stepper valve for hot gas bypass operation. The actuator will have 1596 steps from fully open to fully closed. The discharge gas will be piped to the unit thermostatic expansion valve.
- L. **DUCTING KIT**
Ducting kit with ceiling tile adapter is included with the unit. Duct tubes shall be 10 in. (254 mm) in diameter and 6 ft (1.8 m) long and constructed from UL 181 Class 1 material. Ceiling tile adapter shall be suitable for either 24 in. x 24 in. or 600 mm x 600 mm suspended ceiling grids and constructed of powder coated metal.
- M. **CABLE WATER DETECTOR (OPTIONAL)**
1. A leak detection sensing cable shall be shipped loose with the unit. If water or other conductive liquids contact the cable anywhere along its length, the main controller visually and audibly annunciates an alarm.
 2. The detector shall be provided with a 20 ft (6.1 m) of cable. Additional cable may be cascaded up to 80 ft (24.4 m) total length.
- N. **CABLE SUPPORT BRIDGE TROUGH (OPTIONAL)**
Overhead cable distribution bridge shall connect to adjacent racks and allow for removal of the unit without disrupting the. The trough shall be made of 16 gauge metal with powder coat finish. Trough shall be capable of carrying no less than 80 CAT5 cables.

Worldwide Customer Support

Customer support for this or any other product is available at no charge in any of the following ways:

- Visit the Schneider Electric Web site to access documents in the Schneider Electric Knowledge Base and to submit customer support requests.
 - **www.schneiderelectric.com** (Corporate Headquarters)
Connect to localized Schneider Electric Web sites for specific countries, each of which provides customer support information.
 - **www.schneiderelectric.com/support/**
Global support searching Schneider Electric Knowledge Base and using e-support.
- Contact the Schneider Electric Customer Support Center by telephone or e-mail.
 - Local, country-specific centers: go to **www.schneiderelectric.com > Support > Operations around the world** for contact information.

For information on how to obtain local customer support, contact the representative or other distributors from whom you purchased your product.

As standards, specifications, and designs change from time to time, please ask for confirmation of the information given in this publication.
All trademarks owned by Schneider Electric Industries SAS or its affiliated companies.