



Series vs. Parallel Surge Protection

Series vs. Parallel Surge Protection

When designing and installing power distribution systems, engineers and contractors must select surge protective devices (SPDs) to protect electrical equipment and systems from transient overvoltages. To do so, specifiers must understand the differences between parallel-connected and series-connected SPDs, and where to best apply each type of device. The following narrative summarizes the design and function of parallel-connected and series-connected SPDs, and describes some common applications for each.

OVERVIEW

The proper application includes knowing which type of device is being installed and how the SPD is connected to the power distribution system. In general, a parallel-connected device is installed on an electrical switchboard or panelboard, typically to a dedicated service disconnect, such as a circuit breaker. Alternatively, standalone series-connected filters are connected in-line near protected load equipment. Figure 1 and Figure 2 show each type.

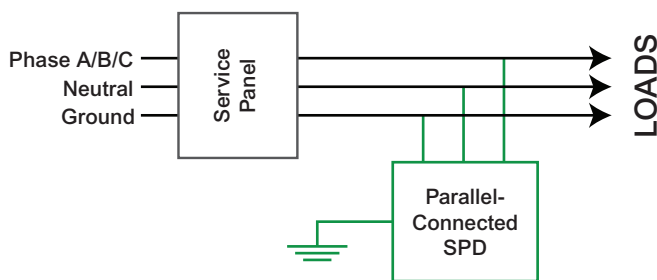

Figure 1: Parallel-Connected SPD

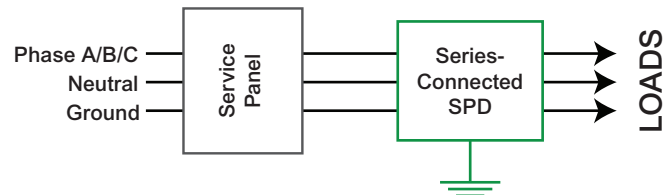

Figure 2: Series-Connected Filter

PARALLEL-CONNECTED DEVICES

Parallel-connected SPDs most commonly use *Metal Oxide Varistors* (MOVs) to divert transient overvoltages from loads. These voltage-sensitive components conduct only when the surge voltage exceeds the varistor's clamping level. As shown in Figures 3 and 4, these SPDs start to shunt excess voltage when voltage exceeds the clamping level. Remnant voltage found below the clamping levels, but above the sine wave, is known as *let-through voltage*.

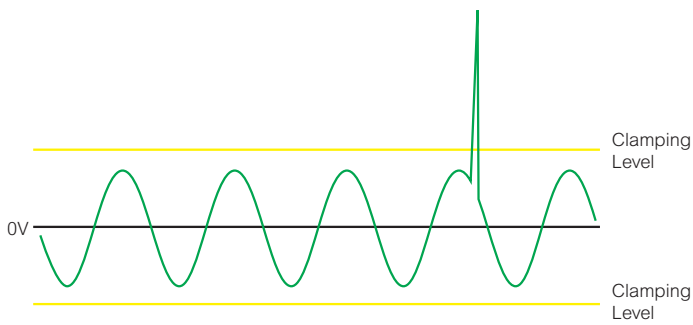

Figure 3: Transient overvoltage on an unprotected circuit

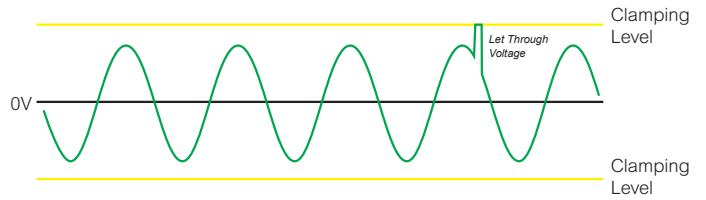

Figure 4: Transient overvoltage on a protected circuit

In parallel-connected SPDs, MOVs are attached across each mode of the electrical system. The lengths of the resulting surge pathways depend on the lengths of the conductors installed to connect the unit to its circuit. The length of leads has a direct effect on device performance, with greater lead lengths equating to greater let-through voltages. Consequently, parallel-connected SPDs should be mounted as close as possible to the panelboards they protect. Figure 5 shows surge pathways through a parallel-connected device.

Parallel-connected SPDs are capable of clamping high-energy low-frequency transients. Their benefits include lower cost and smaller size than series-connected devices, and installation procedures that do not require interruption of power to loads. Their disadvantages include performance differences according to the length of installed leads, instantaneous let-through voltages that vary by phase angle, and lack of attenuation of high-frequency noise.

SERIES-CONNECTED DEVICES

Series-connected devices fall into two broad categories – *series-connected SPDs* and *series-connected filters*. Typically, series-connected SPD designs are wired in series, but internal suppression components are connected in parallel to the circuit. The benefit of this configuration is that lead length is not added during installation, allowing the device to clamp impulses at tighter levels than a parallel-connect unit. The ampere ratings of series-connected units are limited by their lug or terminal block characteristics.

Series-connected filters are designed to protect sensitive equipment, such as computers and digitally controlled equipment, from high-frequency noise that could disrupt reliable operation. Manufacturers offer these products to provide protection from high-frequency, low-energy transient overvoltages as well as noise filtering. As shown in Figure 6, these devices mitigate voltage whenever transient voltages exceed the instantaneous nominal voltage by a specified amount, regardless of phase angle.

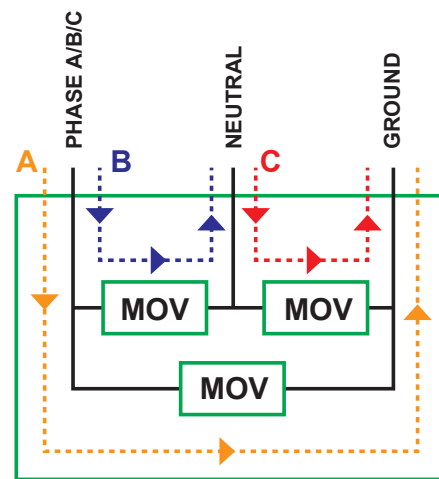

Figure 5: Phase-to-Ground, Phase-to-Neutral, and Neutral-to-Ground pathways in a parallel-connected SPD

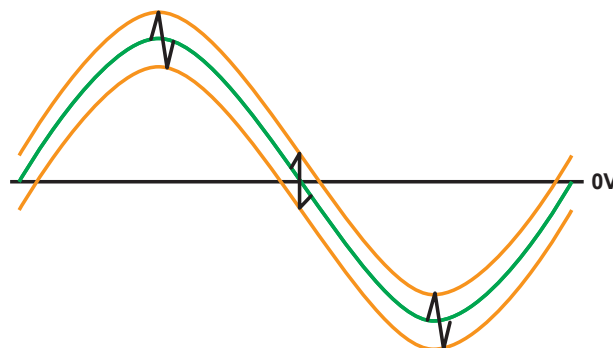

Figure 6: The ASCO Active Tracking™ technology tightly controls let-through voltage, regardless of phase angle.

Series-connected filters use a low-pass circuit (consisting of series-connected inductors, capacitors, and resistors) to eliminate high-frequency noise. Because the entire load current passes through the components, the device must be designed to pass all of the current carried by the circuit it serves. As a result, series-connected filters are typically larger and more costly than parallel-connected devices.

Series-connected filters employ many different technologies. Figure 7 below shows a typical hybrid design with MOVs acting as a first line of defense, clamping the initial overvoltage event. The inductors and capacitors then mitigate the remaining let through voltage, providing a filtered sign wave to the connected equipment.

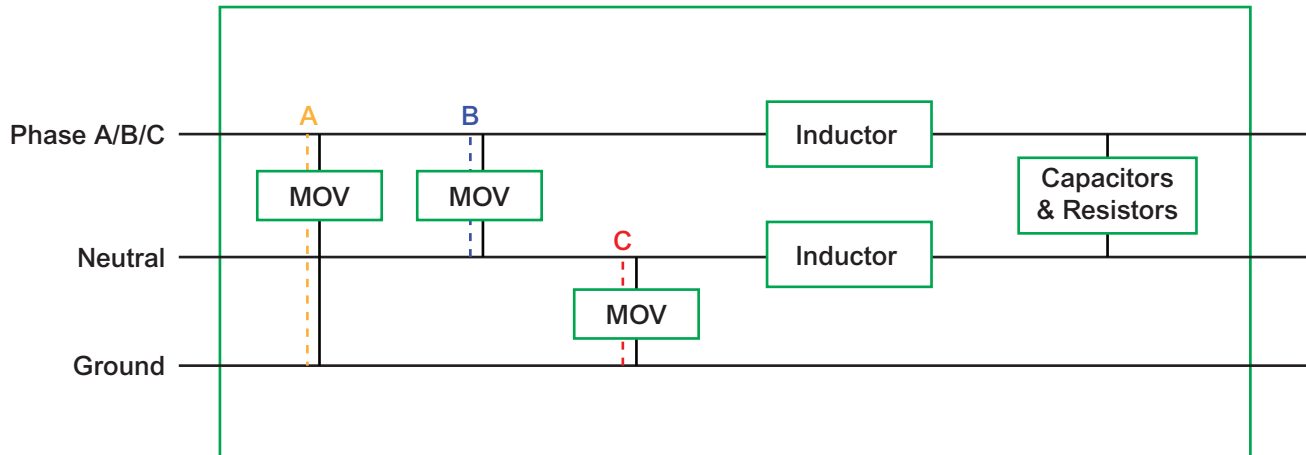

Figure 7: Phase-to-Ground, Phase-to-Neutral, and Neutral-to-Ground pathways in a series-connected filter.

Benefits of series-connected devices include mitigation of potentially damaging high-frequency noise, a tighter clamping voltage, and performance that is independent of installation practices.

DEVICE SELECTION

During the design process, specifiers must decide where to use parallel-connected SPDs and where to use series-connected filters. The appropriate selection could depend on whether protection is needed against damage to equipment, disruption of operations, or both. It also depends on the location in the power distribution where the device will be installed.

Differing types of transients are likely to occur at different locations within a power distribution system. Studies show that 20-30 percent of transient overvoltages originate externally, from environmental and utility sources, and are more likely to consist of high-energy, low-frequency impulses. That means 70-80 percent originate from equipment and operations inside of a facility, and are more likely to consist of low-energy, high-frequency noise, such as ringwaves.

If destructive high-energy transients pose the greatest risks, then a parallel-connected device is likely to be the most cost effective solution. Consequently, parallel-connected devices are most often used at or near a building's service entrance and on panels and equipment that manage large amounts of load. If sensitive equipment could be disrupted by high-frequency noise, then a series-connected filter may be the best choice. Where multiple types of transients may occur or where the characteristics of any power disturbance are unknown, then a staged strategy involving both parallel-connected and series-connected devices should be used. Effective protection is often provided when parallel-connected SPDs are installed at service entrances and distribution panels, and series-connected devices are installed near load equipment. Examples of series-connected and parallel-connected devices are shown in Figure 8 and Figure 9.



Figure 8: Series Connected ASCO Model 285

Figure 9: Parallel Connected ASCO Model 460

APPLICATION EXAMPLES

Parallel-connected SPDs, series-connected SPDs, and series-connected filters all provide protection from transient overvoltages when appropriately applied. Full facility protection can be obtained by cascading devices throughout a facility's power distribution system as well as its communication and data networks (For additional information, review our paper entitled, [Protecting Power Distribution Systems from Transient Overvoltages](#)). Using this approach, more robust units are installed at a building's service entrance and smaller units are installed downstream. Typically, the service entrance will be protected by a parallel-connected SPD with a suitable surge current rating for the facility type and location. Parallel-connected SPDs with lower kA ratings will typically be installed at downstream power distribution panels.

Series-connected filters include in-line surge and noise filtering components, often in conjunction with parallel-connected surge protection components such as MOVs and capacitors. These devices are typically installed downstream from a robust surge protector, to provide additional power filtering and EMI/RFI noise attenuation. Because components are connected in-line, series-connected filters must be sized to handle the entire connected load. Their physical size will change according to ampacity, which can be up to thousands of amps. Consulting a qualified manufacturer is the best way to ensure that the most appropriate units are selected for specific applications.

Most commercial facilities exclusively use parallel-connected SPDs. To provide clean power, a facility may employ a double-conversion UPS ahead of critical computer servers. In such instances, it is important to install an SPD on the input and bypass of the UPS to avoid surge damage to the sensitive electronics within the UPS and the connected load.

Industrial facilities often use SPDs at service entrances and ahead of key panels, motors, and drives. They also use series-connected filters ahead of key processes found in these environments to protect essential equipment. Other common filter applications include broadcast transmission equipment, process control, factory automation systems, sensitive laboratory and medical scanning equipment, and waste water facilities. Traffic cabinets typically use both parallel-connected SPDs and series-connected devices, along with surge protection for low voltage communication signals within enclosures.

SUMMARY

Parallel-connected SPDs typically use voltage-sensitive MOVs that conduct current only when line voltage exceeds their maximum continuous operating voltage. Parallel-connected SPDs are capable of clamping high-energy, low-frequency transients.

Series-connected filters provide protection from low-energy transient overvoltages as well as noise filtering. These devices provide consistent clamping of let-through voltages regardless of phase angle, and are usually installed close to critical loads.

Cascading parallel-connected devices at service entrances and power distribution panels, coupled with series-connected devices at both load equipment and internal sources of transients and noise, can provide comprehensive protection from a range of potentially damaging and disruptive surge events.



ASCO Power Technologies - Global Headquarters

160 Park Avenue
Florham Park, NJ 07932
Tel: 800 800 ASCO

customercare@ascopower.com

whitepapers.ascopower.com

www.ascoapu.com

Surge Protection

14450 58th Street North
Clearwater, FL 33760
Tel: 800 237 4567 (U.S & Canada Only)
727 535 6339 (Outside U.S.)
Fax: 727 539 8955