

# EasyPact MVS

Fixed or Drawout Circuit Breaker or Switch-Disconnecter

固定式或抽出式断路器或负荷隔离开关

Disjoncteur ou interrupteur fixe ou débrochable

Interruptor-seccionador o interruptor automático extraíble o fijo

Disjuntor extraível ou fixo ou interruptor-seccionador

- EN** Instruction sheet
- ZH** 说明页
- FR** Notice de montage
- ES** Hoja de instrucciones
- PT** Folha de instruções

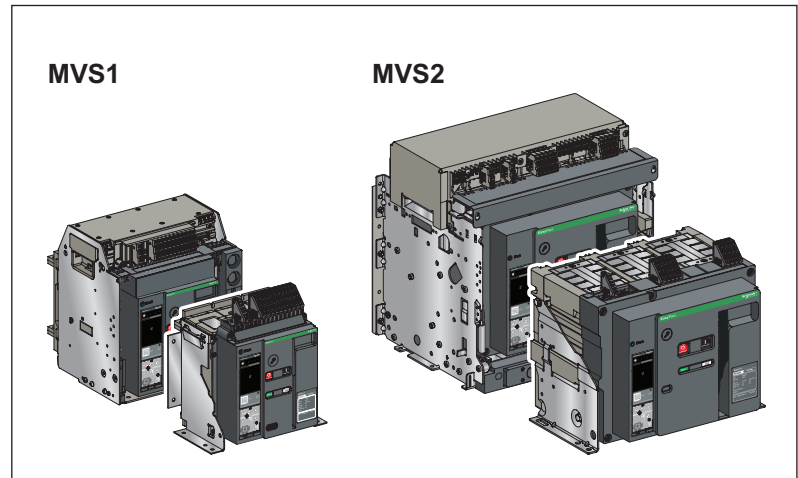

**Schneider**  
Electric™

## Safety Instructions / 安全说明 / Consignes de sécurité / Información de seguridad / Instruções de segurança

<p><b>PLEASE NOTE</b></p> <ul style="list-style-type: none"><li>● Electrical equipment should be installed, operated, serviced, and maintained only by qualified personnel.</li><li>● No responsibility is assumed by Schneider Electric for any consequences arising out of the use of this material.</li><li>● All pertinent state, regional, and local safety regulations must be observed when installing and using this product</li></ul>	<p><b>请注意</b></p> <ul style="list-style-type: none"><li>● 电气设备的安装、操作、维修和维护工作仅限于合格人员执行。</li><li>● Schneider Electric 不承担由于使用本资料所引起的任何后果。</li><li>● 在安装和使用本产品时，必须遵守国家、地区和当地的所有相关的安全法规。</li></ul>	<p><b>REMARQUE IMPORTANTE</b></p> <ul style="list-style-type: none"><li>● L'installation, l'utilisation, la réparation et la maintenance des équipements électriques doivent être assurées par du personnel qualifié uniquement.</li><li>● Schneider Electric décline toute responsabilité quant aux conséquences de l'utilisation de ce matériel.</li><li>● Toutes les réglementations locales, régionales et nationales pertinentes doivent être respectées lors de l'installation et de l'utilisation de ce produit.</li></ul>	<p><b>TENGA EN CUENTA</b></p> <ul style="list-style-type: none"><li>● La instalación, manejo, puesta en servicio y mantenimiento de equipos eléctricos deberán ser realizados sólo por personal cualificado.</li><li>● Schneider Electric no se hace responsable de ninguna de las consecuencias del uso de este material.</li><li>● Al instalar y utilizar este producto es necesario tener en cuenta todas las regulaciones sobre seguridad correspondientes, ya sean regionales, locales o estatales.</li></ul>	<p><b>NOTA</b></p> <ul style="list-style-type: none"><li>● A instalação, utilização e manutenção do equipamento eléctrico devem ser efectuadas exclusivamente por pessoal qualificado.</li><li>● A Schneider Electric não assume qualquer responsabilidade pelas consequências resultantes da utilização deste material.</li><li>● Todas as regulamentações de segurança pertinentes, sejam estatais, regionais ou locais, devem ser cumpridas na instalação e utilização deste produto.</li></ul>
--	--	---	--	--

**⚠ ⚠ DANGER / 危险 / DANGER / PELIGRO / PERIGO**

**HAZARD OF ELECTRIC SHOCK, EXPLOSION OR ARC FLASH**

- Apply appropriate personal protective equipment (PPE) and follow safe electrical work practices. See NFPA 70E, CSA Z462, NOM-029-STPS or local equivalent.
- This equipment must only be installed and serviced by qualified electrical personnel.
- Turn off all power supplying this equipment before working on or inside equipment.
- Always use a properly rated voltage sensing device to confirm power is off.
- Put back all devices, doors, and covers before turning on power to this equipment.
- Beware of potential hazards, and carefully inspect the work area for tools and objects that may have been left inside the equipment.

**Failure to follow these instructions will result in death or serious injury.**

**电击、爆炸或弧闪的危险**

- 采用适当的个人防护设备 (PPE) 并遵循电气作业安全守则。请参阅 NFPA 70E, CSA Z462, NOM-029-STPS 或当地对应的标准。
  - 只有具备相应资质的电气人员才能安装和维修该设备。
  - 在该设备表面或内部工作之前, 请关闭设备的全部电源。
  - 确保使用合适的额定电压传感器确认电源已关闭。
  - 所有设备回到原位, 关上柜门, 然后合闸恢复供电
  - 注意潜在危险, 仔细检查作业区, 以免将工具和物件遗忘在设备内部。
- 未按说明操作将导致人身伤亡等严重后果。**

**RISQUE D'ÉLECTROCUTION, D'EXPLOSION OU ÉCLAIR D'ARC ÉLECTRIQUE**

- Portez un équipement de protection individuel (EPI) adapté et respectez les consignes de sécurité électrique courantes. Reportez-vous aux normes NFPA 70E, CSA Z462, NOM-029-STPS ou aux codes locaux en vigueur.
  - Seul un personnel qualifié doit effectuer l'installation et l'entretien de cet équipement. ce matériel.
  - Débranchez toutes les sources d'alimentation de cet équipement avant d'effectuer toute opération interne ou externe sur celui-ci.
  - Utilisez toujours un dispositif de détection de tension ayant une valeur nominale appropriée pour vous assurer que l'alimentation est coupée.
  - Réinstallez tous les dispositifs, les portes et les couvercles avant de mettre l'équipement sous tension.
  - Faites attention aux dangers potentiels et inspectez attentivement la zone de travail pour vous assurer qu'aucun outil ou objet n'est resté à l'intérieur de l'équipement.
- Le fait de ne pas suivre ces instructions entraînera des blessures graves, voire mortelles.**

**PELIGRO DE DESCARGA ELÉCTRICA, EXPLOSIÓN O DESTELLO POR ARQUEO**

- Utilice equipo de protección personal (EPP) apropiado y siga las prácticas de seguridad eléctricas establecidas. Consulte las normas NFPA 70E, CSA Z462, NOM-029-STPS u otros códigos locales correspondientes.
  - Solamente el personal eléctrico calificado deberá instalar y prestar servicio de mantenimiento a este equipo.
  - Desconecte todas las fuentes de alimentación del equipo antes de realizar cualquier trabajo en él.
  - Siempre utilice un dispositivo de tensión nominal adecuado para confirmar la desenergización del equipo.
  - Vuelva a colocar todos los dispositivos, las puertas y las cubiertas antes de energizar este equipo.
  - Tenga cuidado con los riesgos potenciales, e inspeccione cuidadosamente la zona de trabajo para comprobar si han quedado herramientas y objetos dentro del equipo.
- El incumplimiento de estas instrucciones tendrá como resultado la muerte o lesiones graves.**

**RISCO DE ELECTROCUSSÃO, DE EXPLOSIÃO, OU DE ARCO ELÉTRICO**

- Utilize equipamento de proteção pessoal (PPE) e siga os métodos de segurança elétrica. Consulte NFPA 70E, CSA Z462, NOM-029-STPS ou o equivalente local.
  - A instalação e manutenção deste equipamento só devem ser efectuadas por electricistas qualificados.
  - Desligue todas as fontes de alimentação deste equipamento antes de trabalhar no equipamento ou no seu interior.
  - Utilize sempre um dispositivo de detecção da tensão nominal adequada para confirmar se a alimentação está desligada.
  - Instale de novo todos os dispositivos, portas e tampas antes de ligar a alimentação deste equipamento.
  - Esteja atento a potenciais perigos e inspecione cuidadosamente a área de trabalho para se assegurar que não foram deixadas ferramentas e objectos no interior do equipamento.
- O não cumprimento destas instruções resultará em morte e lesões graves.**

## Contents / 目录 / Sommaire / Sumario / Índice

<b>1</b>	Device Operation / 设备操作 / Fonctionnement de l'appareil / Funcionamiento del aparato / Funcionamento do dispositivo	5	<b>10</b>	Installation / 安装 / Installation / Instalación / Instalação	30
<b>2</b>	Chassis Operation / 抽架操作 / Fonctionnement du châssis / Funcionamiento del chasis / Funcionamento do chassis	7	<b>11</b>	Clearance Distances / 间距 / Distances d'isolement / Distancias de separación / Distâncias de folga	34
<b>3</b>	Storage / 存储 / Stockage / Almacenamiento / Armazenamento	9	<b>12</b>	Power Connections / 扩展端子 / Raccordement puissance / Conexión potencia / Conexões de energia	36
<b>4</b>	Precautions Before Carrying Out Any Work / 操作须知 / Précautions préalables à toute intervention / Precauciones antes de llevar a cabo cualquier tarea / Precauções prévias à realização do trabalho	11	<b>13</b>	Interphase Barriers / 相间隔板 / Séparateurs de phases / Barreras interfásicas / Barreiras interfásicas	45
<b>5</b>	Package Identification / 包装标识 / Identification du package / Identificación del paquete / Identificação do pacote	13	<b>14</b>	Auxiliary Connections / 辅助连接 / Raccordement auxiliaire / Conexión auxiliar / Conexões auxiliares	51
<b>6</b>	Manufacturing Date / 制造日期 / Date de fabrication / Fecha de fabricación / Data de fabrico	14	<b>15</b>	Wiring Diagrams / 电气连接 / Schémas électriques / Diagramas de cableado / Diagramas de cablagem	56
<b>7</b>	Necessary Tools / 必备工具 / Outillage nécessaire / Herramientas necesarias / Ferramentas necessárias	15	<b>16</b>	Radio Frequency Compliance Statement for TS Trip System / TS 脱扣单元的射频合规声明 / Déclaration de conformité des fréquences radio pour le système de déclenchement TS / Declaración de cumplimiento de la radiofrecuencia para el sistema de disparo TS / Declaração de conformidade de radiofrequência para sistema de disparo TS	59
<b>8</b>	Unpacking / 拆封 / Déballage / Desembalaje / Abertura da embalagem	17	<b>17</b>	TS Trip System Setting / TS 脱扣单元设置 / Réglage du système de déclenchement TS / Configuración del sistema de disparo TS / Definição do sistema de disparo TS	60
<b>9</b>	Handling / 搬运 / Manutention / Transport / Manuseio	23			

# MVS1: Device Operation / 设备操作 / Fonctionnement de l'appareil / Funcionamiento del aparato / Funcionamento do dispositivo

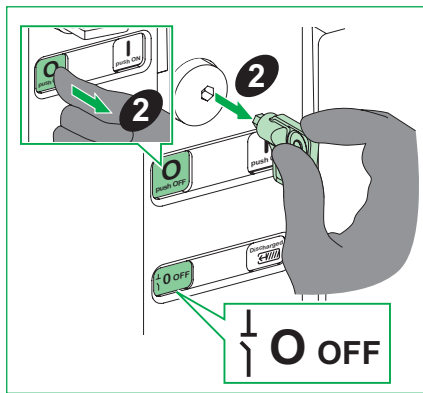
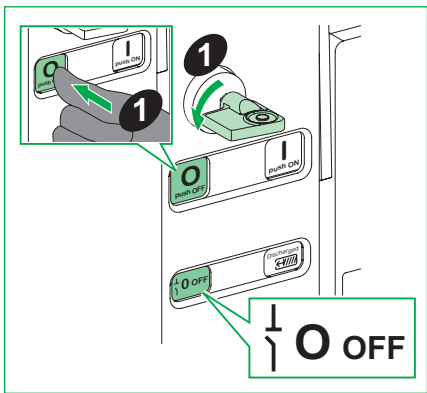
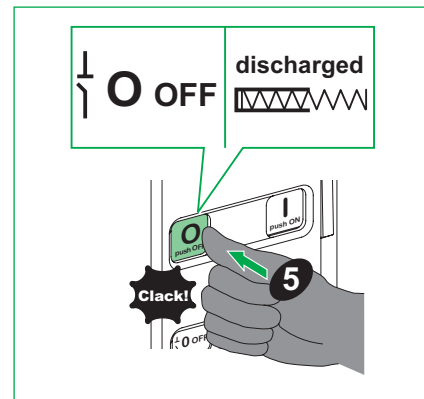
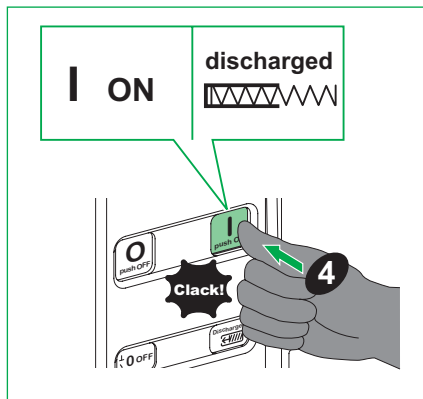
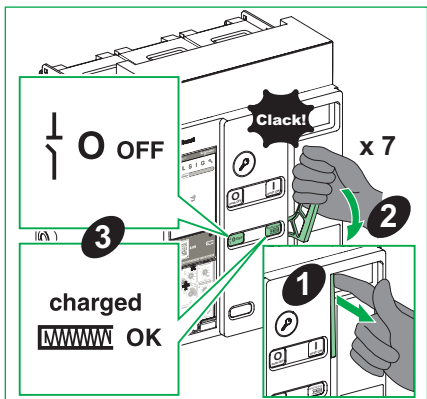

MVS2: Device Operation / 设备操作 / Fonctionnement de l'appareil / Funcionamiento del aparato / Funcionamento do dispositivo

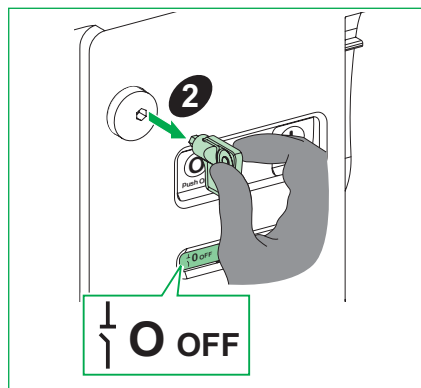
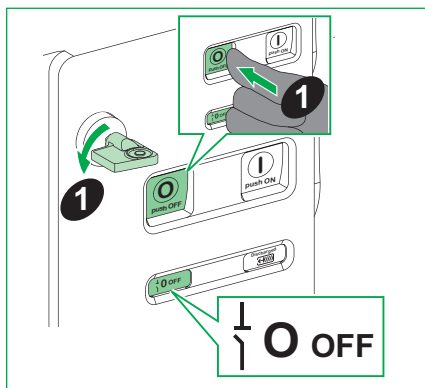
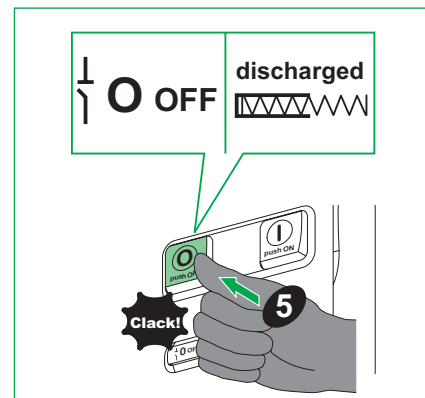
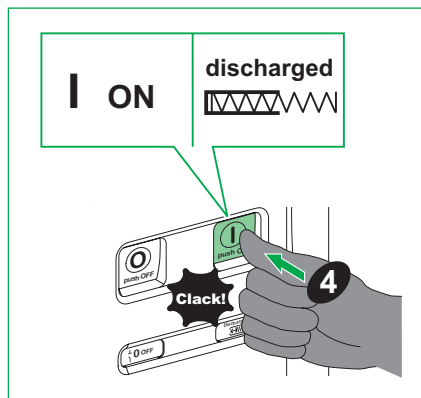
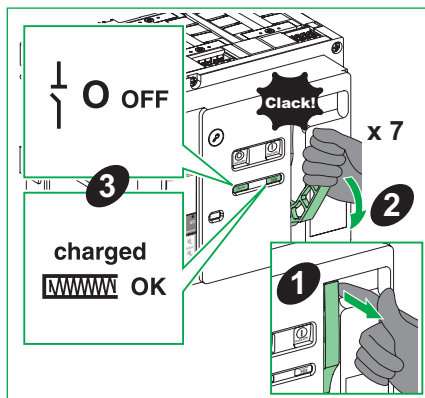

# MVS1: Chassis Operation / 抽架操作 / Fonctionnement du châssis / Funcionamiento del chasis / Funcionamento do chassis

Drawout circuit breaker / 抽出式断路器 / Disjoncteur débrochable / Interruptor automático extraíble / Disjuntor de descarga

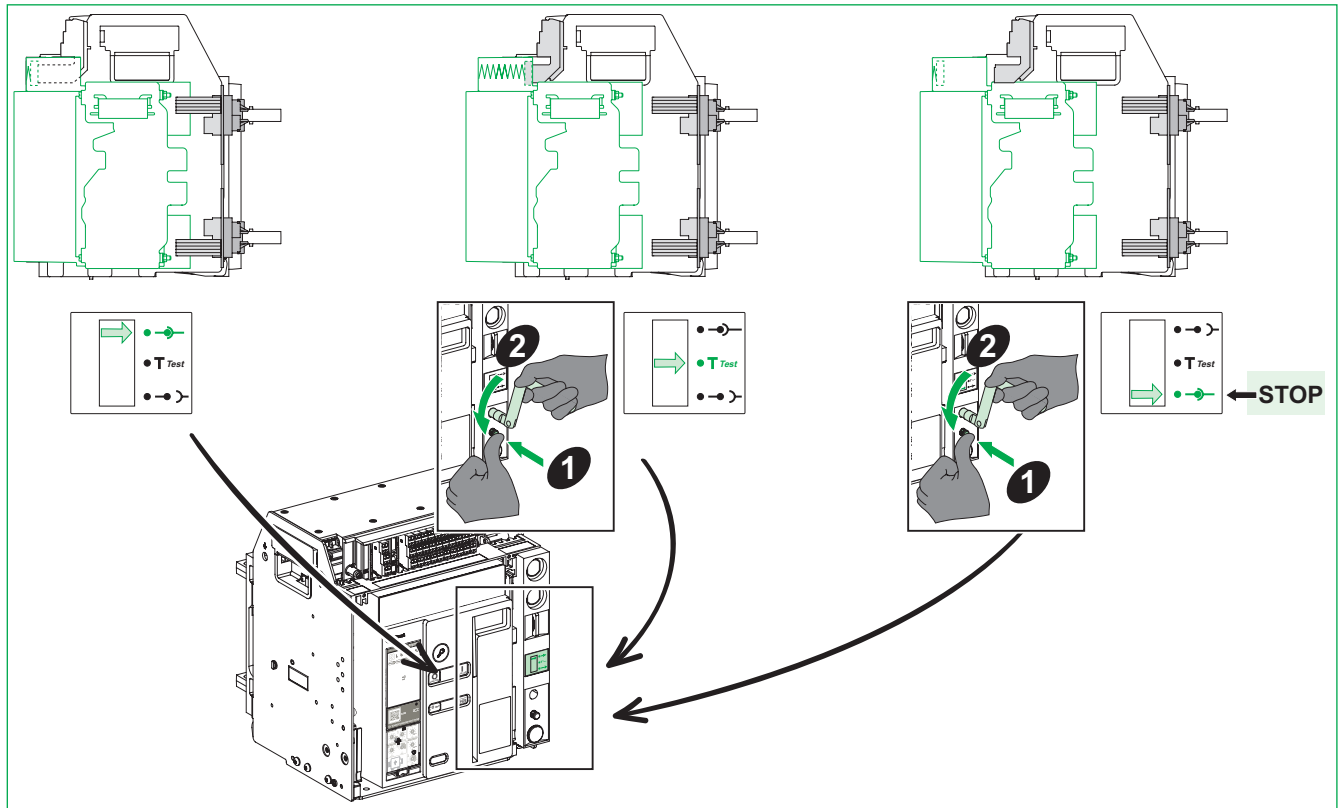

# MVS2: Chassis Operation / 抽架操作 / Fonctionnement du châssis / Funcionamiento del chasis / Funcionamento do chassis

Drawout circuit breaker / 抽出式断路器 / Disjoncteur débrochable / Interruptor automático extraíble / Disjuntor de descarga

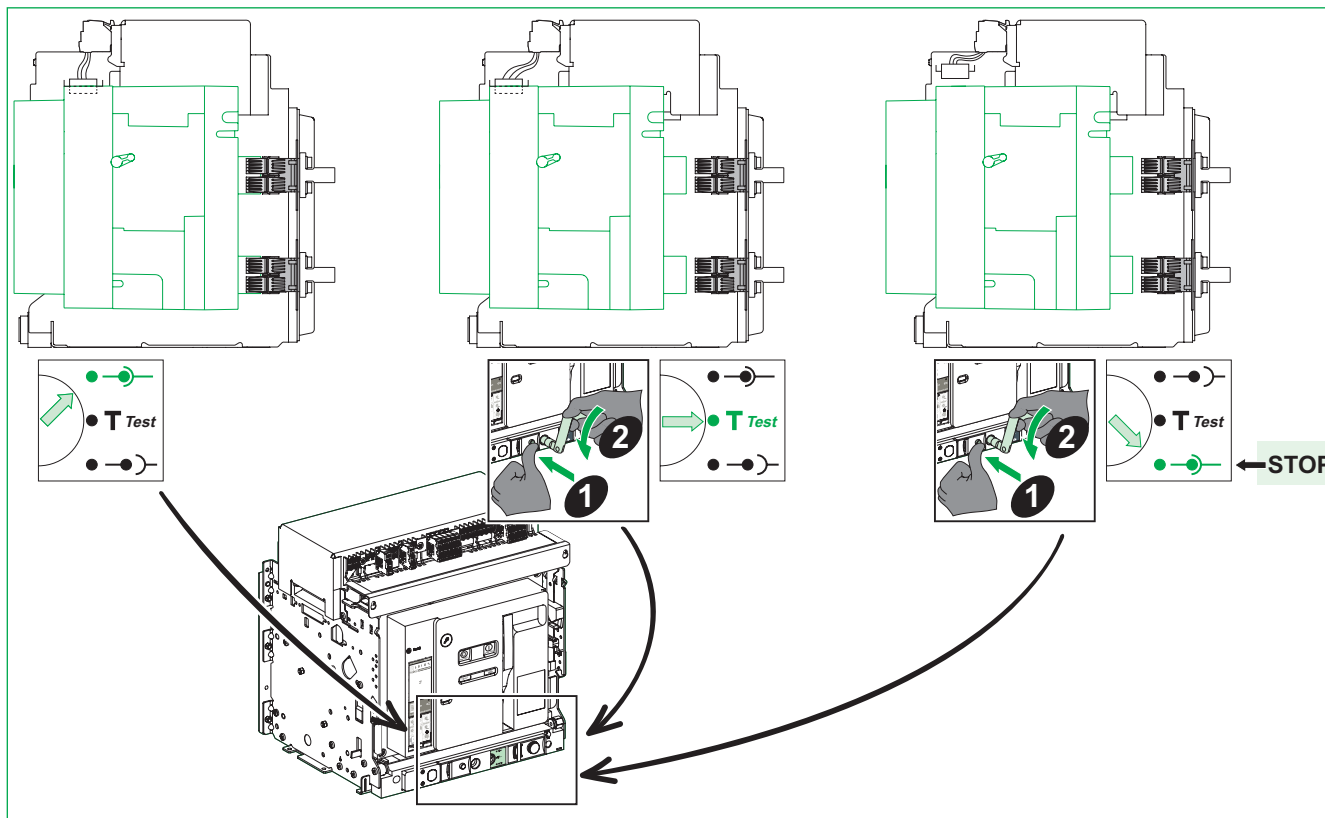

Storage / 存储 / Stockage / Almacenamiento / Armazenamento

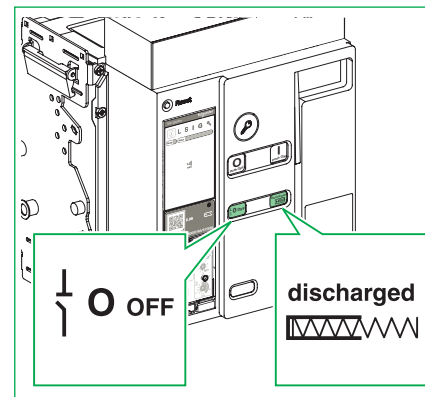
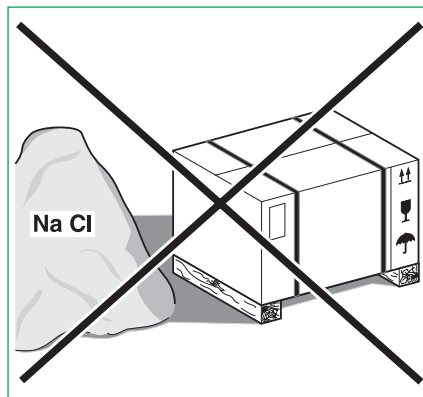
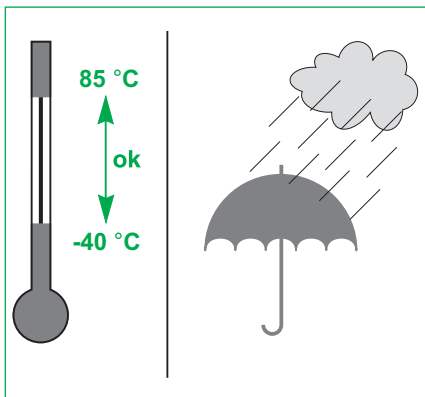

(MVS1)

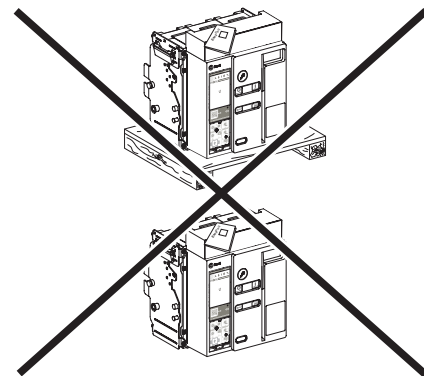
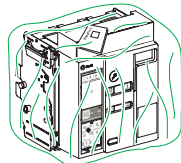
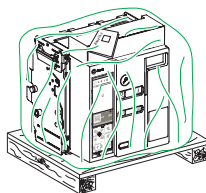
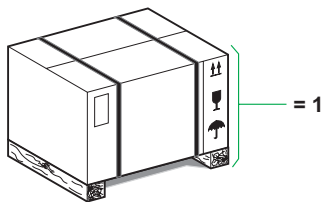

(MVS2)

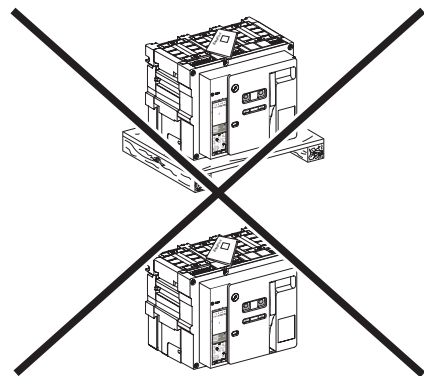
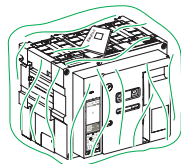
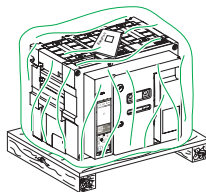
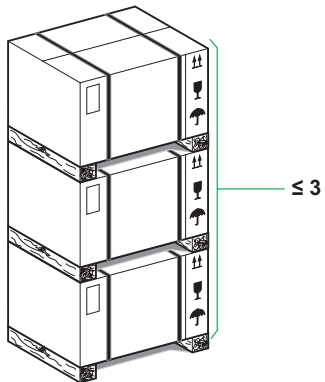

## MVS1: Precautions Before Carrying Out Any Work / 操作须知 / Précautions préalables à toute intervention / Precauzioni da adottare prima di iniziare qualsiasi intervento / Precauções prévias à realização do trabalho

<p><b>PLEASE NOTE</b> Before carrying out any work, always de-energize the device as indicated here. Withdrawable devices should be moved to disconnected position.</p>	<p><b>请注意</b> 在执行任何操作前，将设备置于不带电状态。 抽出式设备应移至断开位置。</p>	<p><b>REMARQUE IMPORTANTE</b> Avant toute intervention, mettez toujours l'appareil hors tension comme indiqué ici. Les appareils débrochables doivent être mis en position Débroché.</p>	<p><b>TENGA EN CUENTA</b> Antes de realizar cualquier trabajo, siempre corte la corriente del dispositivo como se indica aquí. Los dispositivos extraíbles deben colocarse en la posición de desconectado.</p>	<p><b>NOTE</b> Antes de efetuar qualquer trabalho, desative sempre o dispositivo conforme indicado aqui. Os dispositivos removíveis devem ser movidos para a posição desligada.</p>
---	--	--	--	---

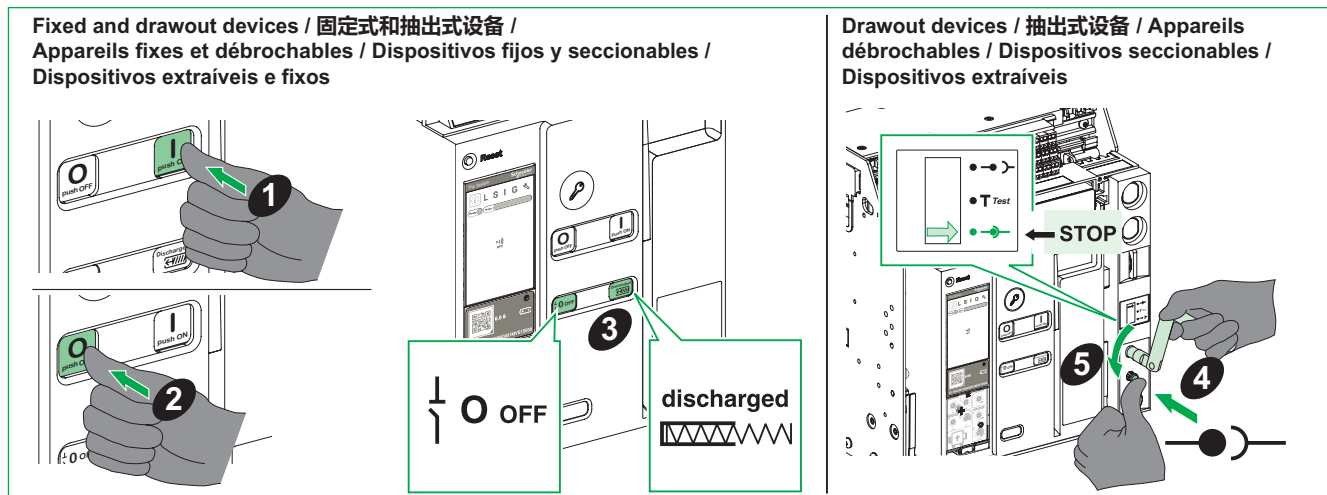

# MVS2: Precautions Before Carrying Out Any Work / 操作须知 / Précautions préalables à toute intervention / Precauzioni da adottare prima di iniziare qualsiasi intervento / Precauções prévias à realização do trabalho

<p><b>PLEASE NOTE</b> Before carrying out any work, always de-energize the device as indicated here. Withdrawable devices should be moved to disconnected position.</p>	<p><b>请注意</b> 在执行任何操作前，将设备置于不带电状态。 抽出式设备应移至断开位置。</p>	<p><b>REMARQUE IMPORTANTE</b> Avant toute intervention, mettez toujours l'appareil hors tension comme indiqué ici. Les appareils débrochables doivent être mis en position Débroché.</p>	<p><b>TENGA EN CUENTA</b> Antes de realizar cualquier trabajo, siempre corte la corriente del dispositivo como se indica aquí. Los dispositivos extraíbles deben colocarse en la posición de desconectado.</p>	<p><b>NOTE</b> Antes de efetuar qualquer trabalho, desative sempre o dispositivo conforme indicado aqui. Os dispositivos removíveis devem ser movidos para a posição desligada.</p>
---	--	--	--	---

**Fixed and drawout devices / 固定式和抽出式设备 / Appareils fixes et débrochables / Dispositivos fijos y seccionables / Dispositivos extraíveis e fixos**

**Drawout devices / 抽出式设备 / Appareils débrochables / Dispositivos seccionables / Dispositivos extraíveis**

Package Identification / 包装标识 / Identification du package / Identificación del paquete /  
Identificação da embalagem

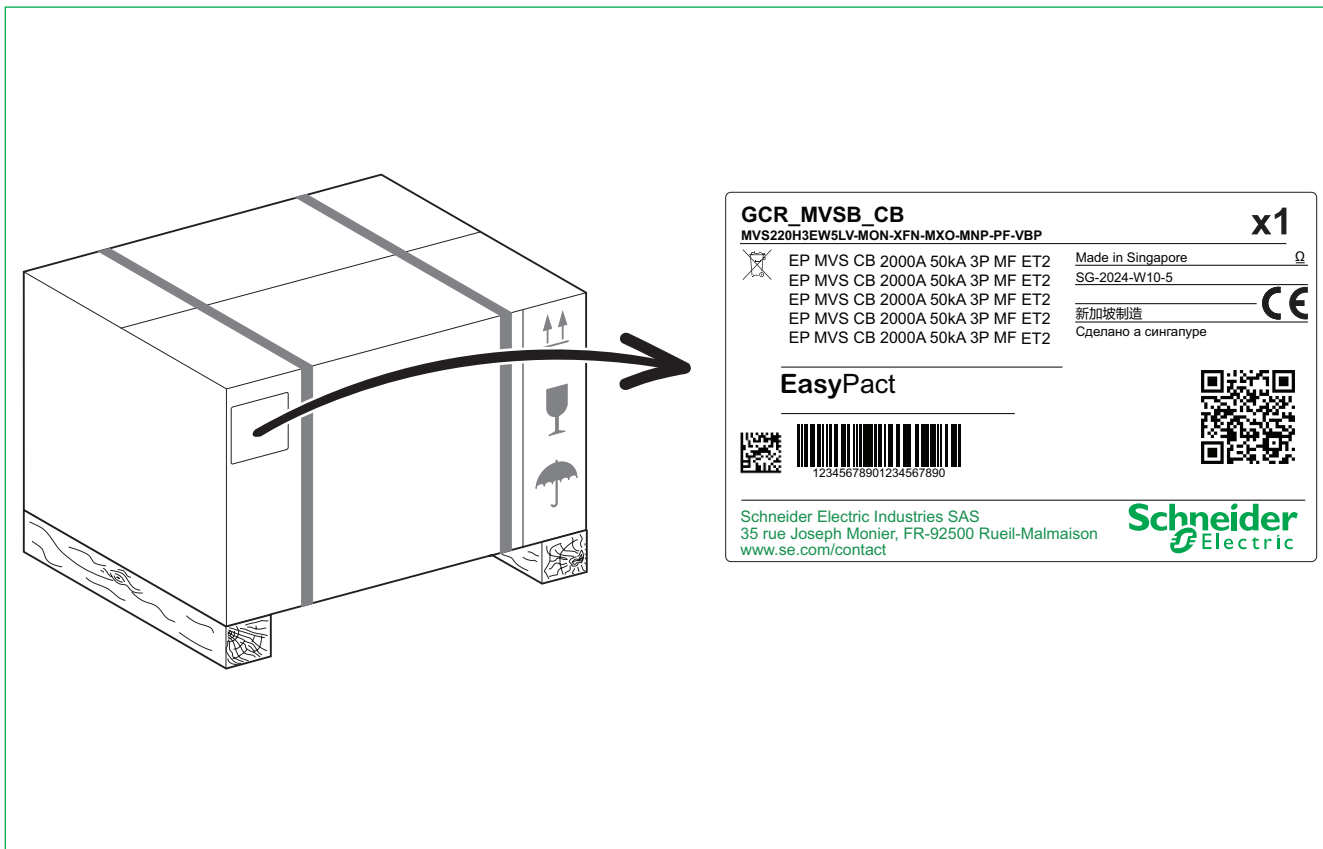

## Manufacturing Date / 制造日期 / Date de fabrication / Fecha de fabricación / Data de fabrico

<p>The circuit breaker manufacturing date indicated on the product identification label is coded PYYWWDNNNN, where:</p> <ul style="list-style-type: none"> <li>● PP: plant code</li> <li>● YY: year of manufacture</li> <li>● WW: week of manufacture</li> <li>● D: weekday of manufacture (Monday = 1)</li> <li>● NNNN: Manufacturing rank order of the product in the day, from 0001 to 9999</li> </ul> <p>Eg: PP240820001 = first product manufactured at plant PP on Tuesday 20 February 2024.</p>	<p>产品制造日期采用如下代码 PYYWWDNNNN, 其中:</p> <ul style="list-style-type: none"> <li>● PP: 工厂代码</li> <li>● YY: 制造年份</li> <li>● WW: 第几周制造</li> <li>● D: 星期几制造 (星期一 = 1)</li> <li>● NNNN: 当天产品的制造次序, 从 0001 到 9999</li> </ul> <p>例如: PP240820001 = 第一件产品 2024 年 2 月 20 日星期二在 PP 工厂生产。</p>	<p>La date de fabrication du disjoncteur indiquée sur l'étiquette d'identification du produit est codée sous la forme PYYWWDNNNN, où:</p> <ul style="list-style-type: none"> <li>● PP: code usine</li> <li>● YY: année de fabrication</li> <li>● WW: semaine de fabrication</li> <li>● D: jour de fabrication dans la semaine (lundi = 1)</li> <li>● NNNN: ordre de fabrication du produit dans la journée, de 0001 à 9999</li> </ul> <p>Exemple: PP240820001 = premier produit fabriqué à l'usine PP le mardi 20 février 2024.</p>	<p>La fecha de fabricación del interruptor automático que se señala en la etiqueta de identificación del producto está codificada PYYWWDNNNN, donde:</p> <ul style="list-style-type: none"> <li>● PP: código de planta</li> <li>● YY: año de fabricación</li> <li>● WW: semana de fabricación</li> <li>● D: día de la semana de fabricación (lunes = 1)</li> <li>● NNNN: Orden de clasificación de fabricación del producto en el día, del 0001 al 9999</li> </ul> <p>Por ejemplo: PP240820001 = el primer producto que se fabricará en la planta PP el martes 20 de febrero de 2024.</p>	<p>A data de fabrico do disjuntor indicada na etiqueta de identificação do produto está codificada PYYWWDNNNN, em que:</p> <ul style="list-style-type: none"> <li>● PP: código de fábrica</li> <li>● YY: ano de fabrico</li> <li>● WW: semana de fabrico</li> <li>● D: dia útil de fabrico (segunda-feira = 1)</li> <li>● NNNN: Ordem de classificação de fabrico do produto no dia, de 0001 a 9999</li> </ul> <p>Por exemplo: PP240820001 = primeiro produto fabricado na fábrica PP na terça-feira, 20 de fevereiro de 2024.</p>
--	---	---	---	--

## MVS1: Necessary Tools / 必备工具 / Outillage nécessaire / Herramientas necesarias / Ferramentas necessárias

Hex key, angled socket wrench, screwdriver  
(Pozidrive n°2, 3 or slotted).

内六角扳手、弯头套筒扳手、螺丝刀  
(Pozidrive 2号、3号螺丝刀和一字螺丝刀)

Clé hexagonale, clé à douille coudée, tournevis  
(Pozidrive n°2, 3 ou plat).

Llave hexagonal, llave de tubo angular,  
desarmador (punta Pozidrive n.º 2, 3 o ranurado).

Chave hexadecimal, chave de fenda com ranhura  
diagonal, chave de fendas (Pozidrive n.º 2, 3 ou  
ranhura).

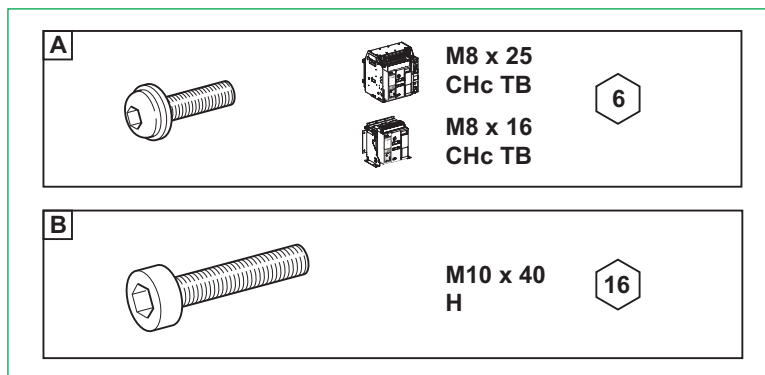
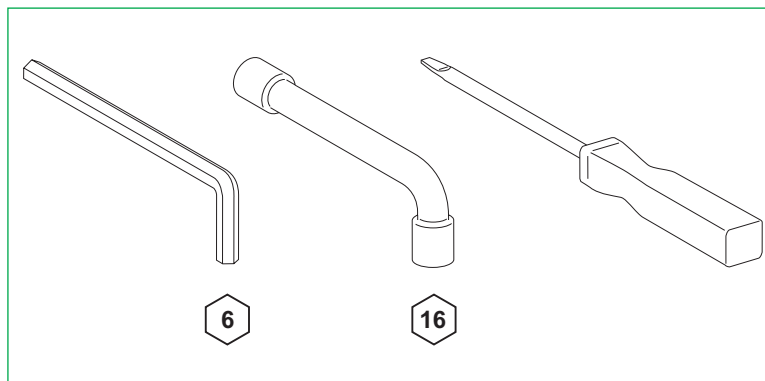

## MVS2: Necessary Tools / 必备工具 / Outillage nécessaire / Herramientas necesarias / Ferramentas necessárias

Hex key, angled socket wrench, screwdriver  
(Pozidrive n°2, 3 or slotted).

内六角扳手、弯头套筒扳手、螺丝刀  
(Pozidrive 2号、3号螺丝刀和一字螺丝刀)

Clé hexagonale, clé à douille coudée, tournevis  
(Pozidrive n°2, 3 ou plat).

Llave hexagonal, llave de tubo angular,  
desarmador (punta Pozidrive n.º 2, 3 o ranurado).

Chave hexadecimal, chave de fenda com ranhura  
diagonal, chave de fendas (Pozidrive n.º 2, 3 ou  
ranhura).

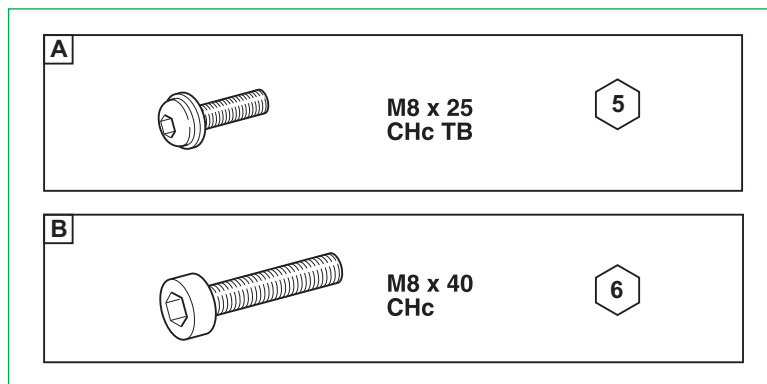
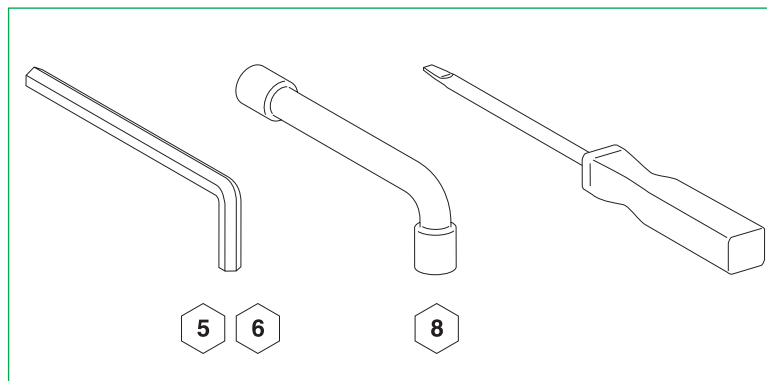

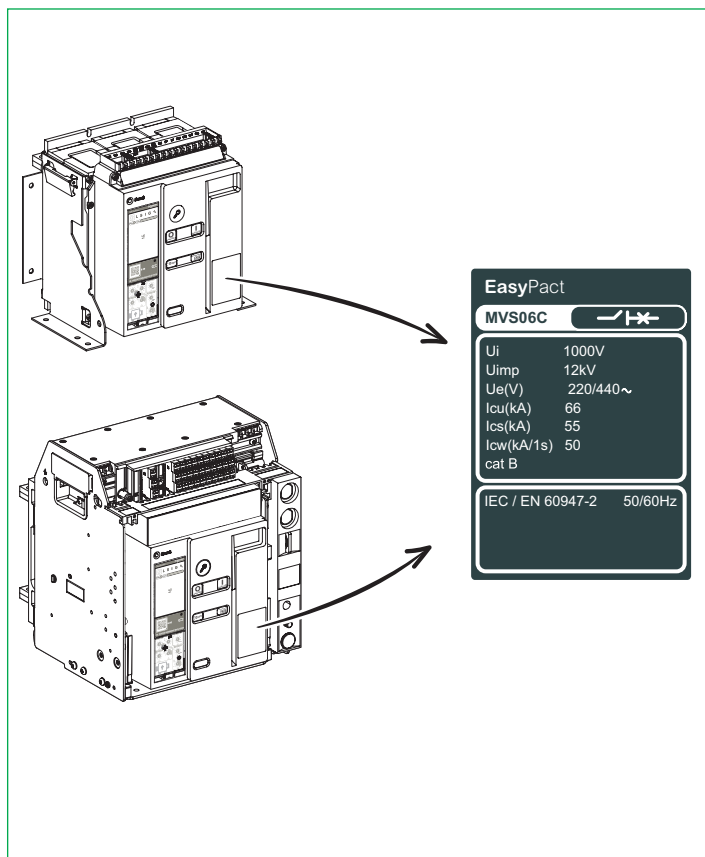
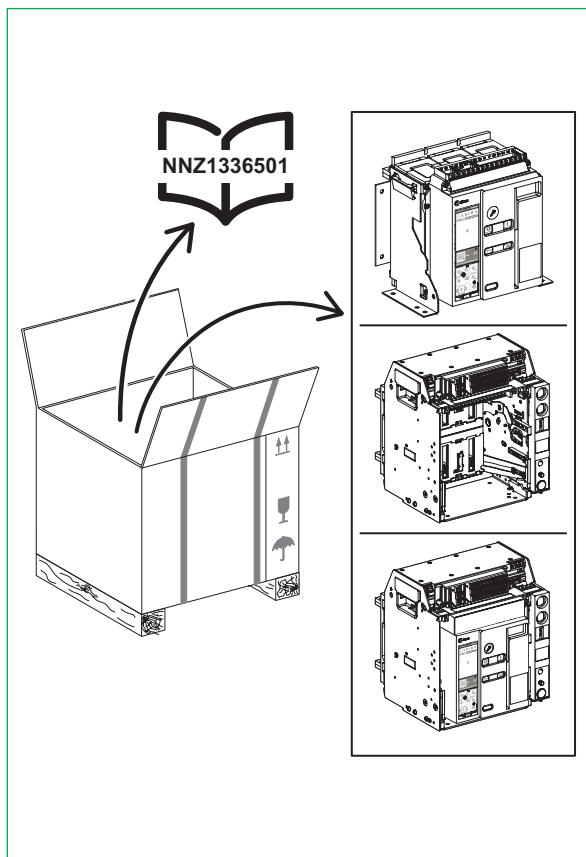

# MVS1: Unpacking / 拆封 / Déballage / Desembalaje / Abertura da embalagem

Chassis only / 仅抽架 / Châssis seul /  
Chasis solo / Somente chasis

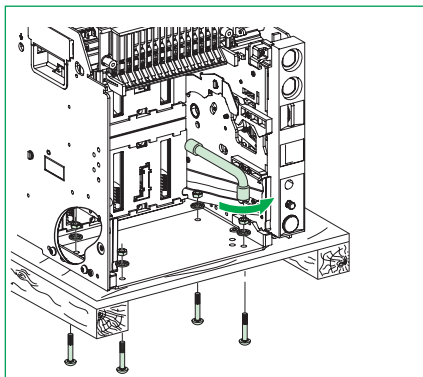

Fixed circuit breaker / 固定式断路器 / Disjoncteur fixe / Interruptor automático fijo /  
Disjuntor fixo

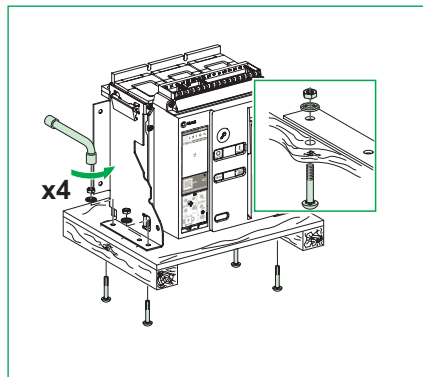

# MVS1: Unpacking / 拆封 / Déballage / Desembalaje / Abertura da embalagem

Drawout circuit breaker with chassis / 抽出式断路器 / Disjoncteur débrochable avec châssis / Interruptor automático seccionable con chasis / Disjuntor extraível com chasis

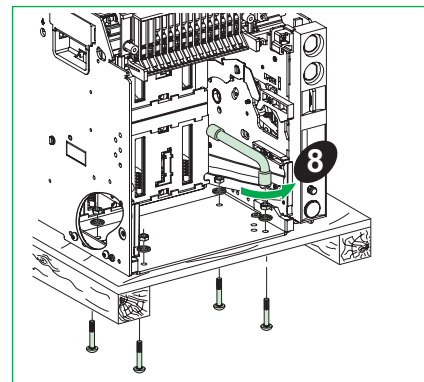
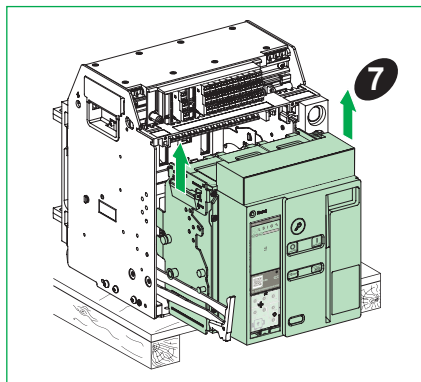
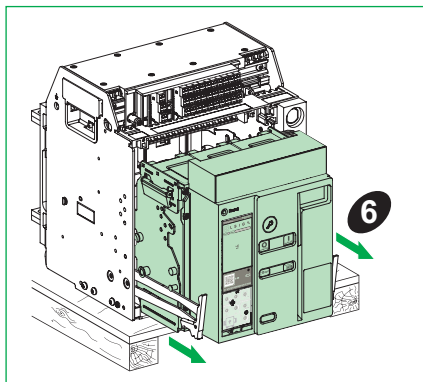
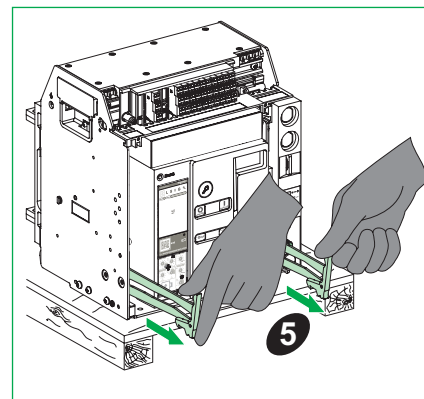
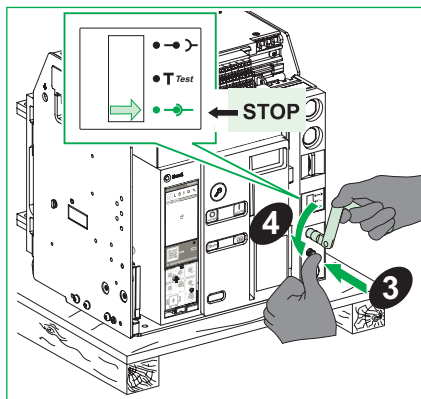
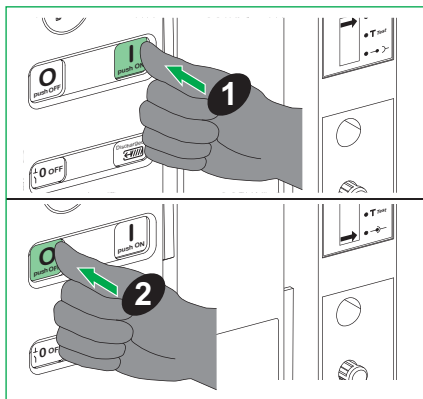

MVS2: Unpacking / 拆封 / Déballage / Desembalaje / Abertura da embalagem

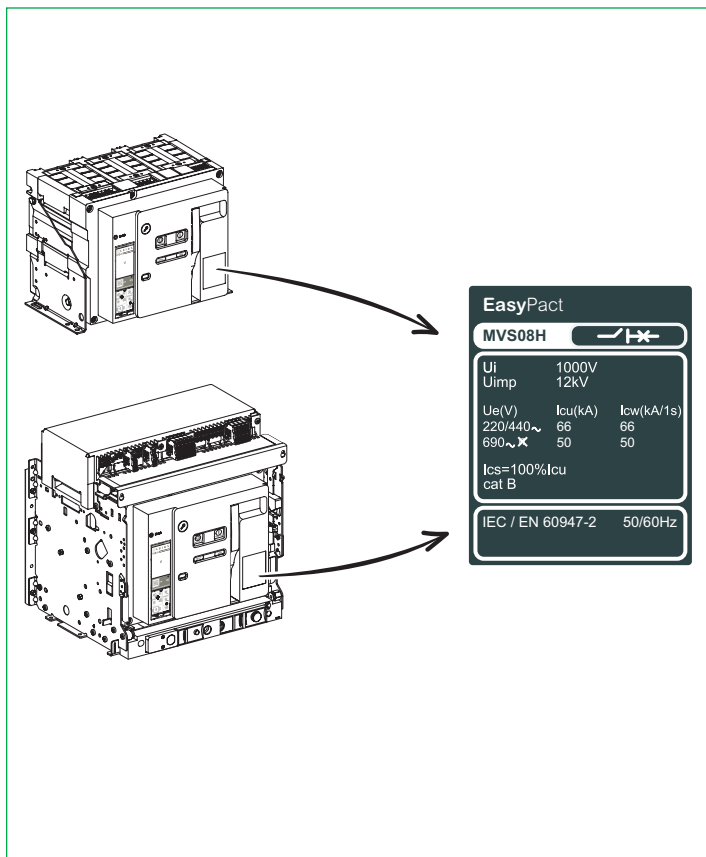
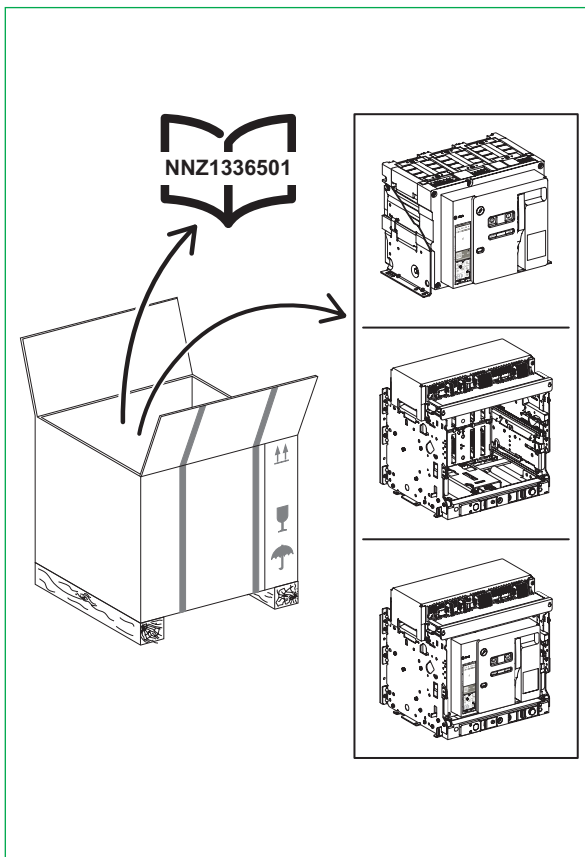

## MVS2: Unpacking / 拆封 / Déballage / Desembalaje / Abertura da embalagem

Chassis only / 仅抽架 / Châssis seul /  
Chassis solo / Somente chassis

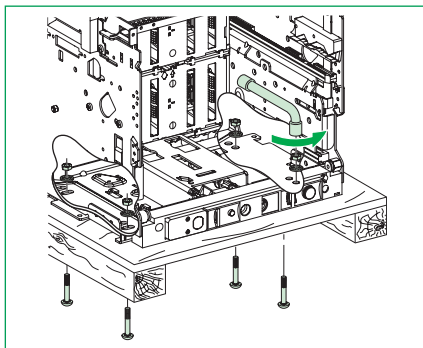

Fixed and drawout circuit breaker without chassis / 固定式和抽出式不带抽架的断路器 /  
Disjoncteur fixe et débrochable sans châssis / Interruptor automático extraíble o fijo  
sin chasis / Disjuntor extraível e fixo sem chassis

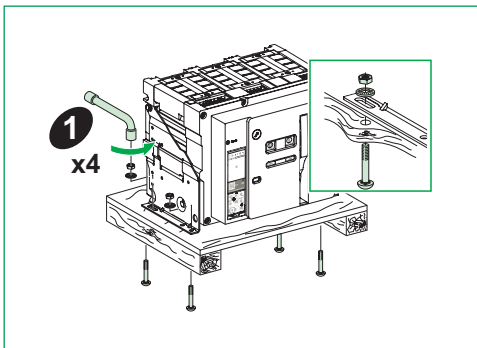

Drawout circuit breaker without chassis / 抽出式断路器, 不带抽架 /  
Disjoncteur débrochable sans châssis / Interruptor automático extraíble sin chasis /  
Disjuntor extraível sem chassis

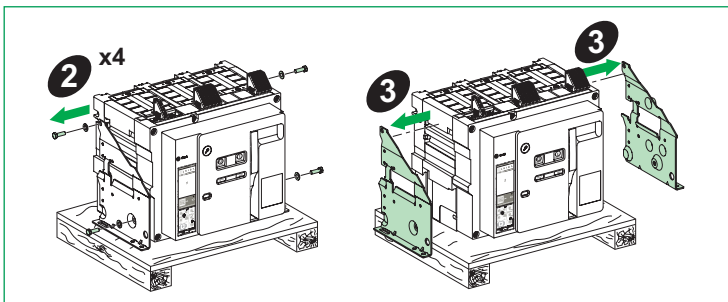

## MVS2: Unpacking / 拆封 / Déballage / Desembalaje / Abertura da embalagem

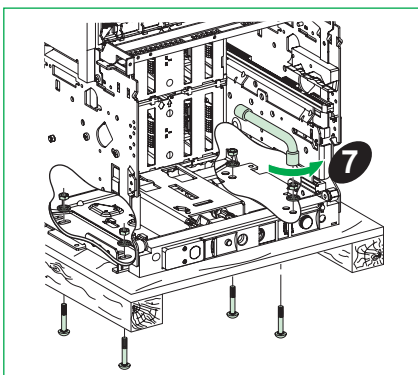
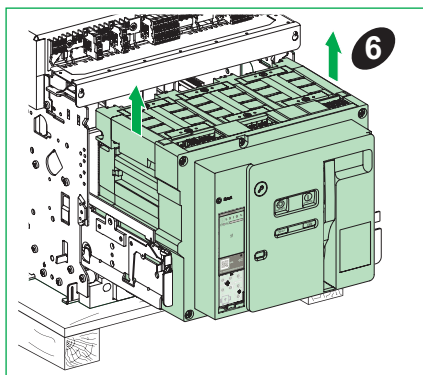
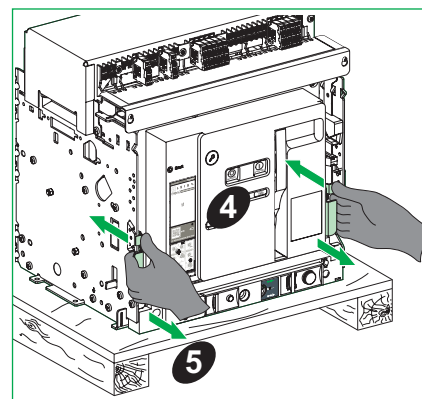
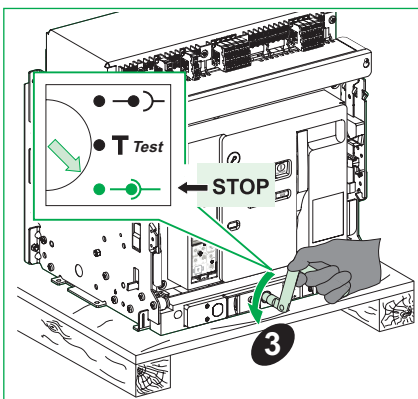
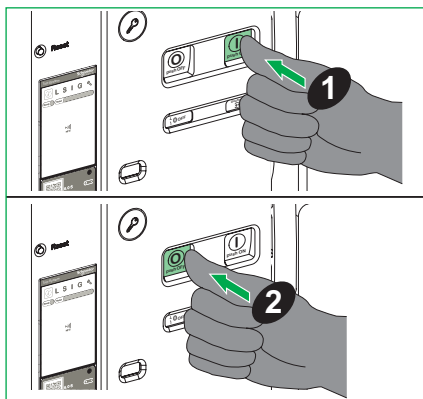

Drawout circuit breaker with chassis / 抽出式断路器 / Disjoncteur débrochable avec châssis / Interruptor automático seccionable con chasis / Disjuntor extraível com chasis



**⚠️ ⚠️ DANGER / 危险 / DANGER / PELIGRO / PERIGO**

<p><b>HAZARD OF DEVICE FALLING</b></p> <ul style="list-style-type: none"> <li>● Be sure lifting equipment has lifting capacity for the device being lifted.</li> <li>● Follow manufacturer's instructions for use of lifting equipment.</li> <li>● Wear hard hat, safety shoes and heavy gloves.</li> </ul> <p><b>Failure to follow these instructions will result in death or serious injury.</b></p>	<p><b>设备坠落风险</b></p> <ul style="list-style-type: none"> <li>● 确保吊装设备有足够的吊装能力来吊起设备。</li> <li>● 关于吊装设备的使用，请遵循制造商说明。</li> <li>● 穿戴安全帽、安全鞋和厚手套。</li> </ul> <p><b>未按说明操作将导致人身伤亡等严重后果。</b></p>	<p><b>RISQUE DE CHUTE DE L'APPAREIL</b></p> <ul style="list-style-type: none"> <li>● Assurez-vous que l'équipement de levage présente une capacité adaptée.</li> <li>● Suivez les instructions du fabricant pour utiliser l'équipement de levage.</li> <li>● Portez un casque, des chaussures de sécurité et des gants lourds.</li> </ul> <p><b>Le fait de ne pas suivre ces instructions entrainera des blessures graves, voire mortelles.</b></p>	<p><b>PELIGRO DE CAÍDA DEL DISPOSITIVO</b></p> <ul style="list-style-type: none"> <li>● Asegúrese de que el equipo de izamiento tenga la capacidad de levantamiento para el dispositivo que se elevará.</li> <li>● Siga las instrucciones del fabricante para el uso del equipo de izamiento.</li> <li>● Utilice casco, zapatos de seguridad y guantes de uso pesado.</li> </ul> <p><b>El incumplimiento de estas instrucciones tendrá como resultado la muerte o lesiones graves.</b></p>	<p><b>PERIGO DE QUEDA DO DISPOSITIVO</b></p> <ul style="list-style-type: none"> <li>● O equipamento de elevação deve ter capacidade de elevação para o dispositivo que está a ser içado.</li> <li>● Siga as instruções do fabricante sobre como utilizar o equipamento de elevação.</li> <li>● Use um capacete, calçado de segurança e luvas grossas.</li> </ul> <p><b>O não cumprimento destas instruções resultará em morte e lesões graves.</b></p>
--	--	---	--	--

MVS1: Handling / 搬运 / Manutention / Transport / Manuseio

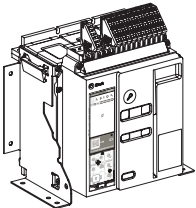
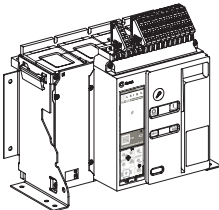
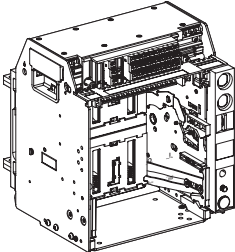
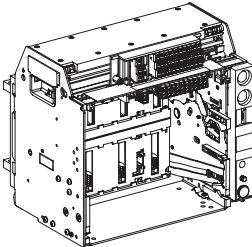
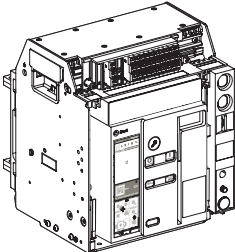
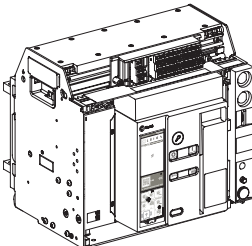
3P	 Kg	4P	 Kg
	$\leq 18 \text{ kg}$		$\leq 21 \text{ kg}$
	$\leq 18 \text{ kg}$		$\leq 21 \text{ kg}$
	$\leq 35 \text{ kg}$		$\leq 41 \text{ kg}$

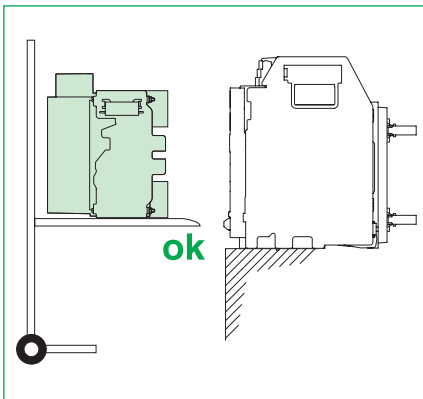
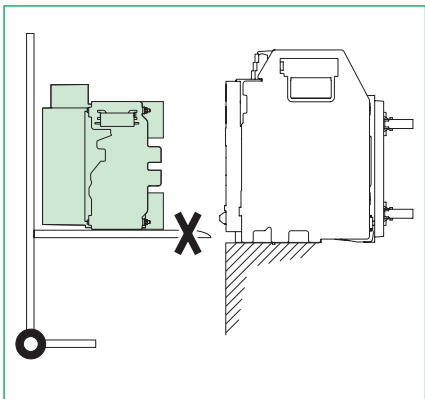
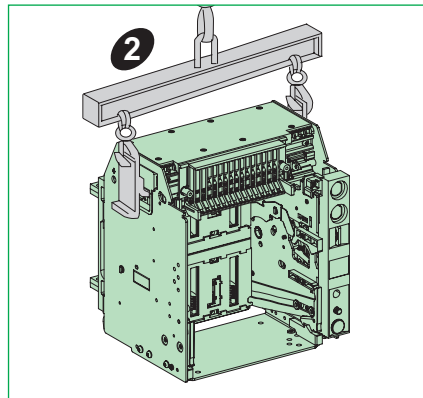
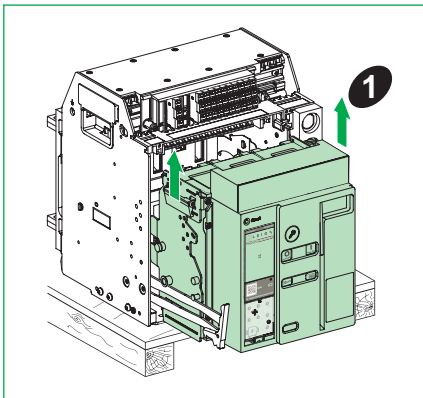
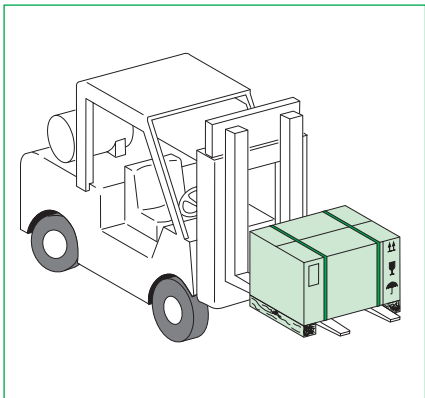

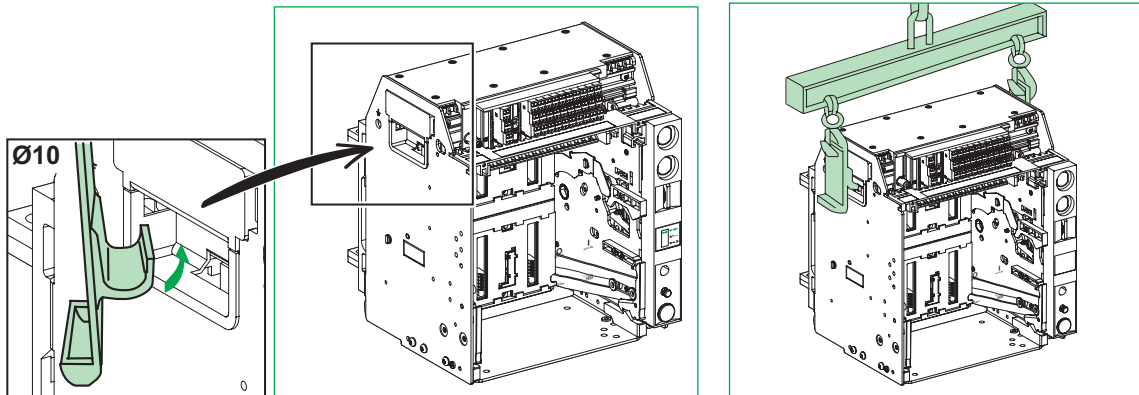

Chassis only  
仅抽架  
Châssis seul  
Chasis solo  
Somente chassis

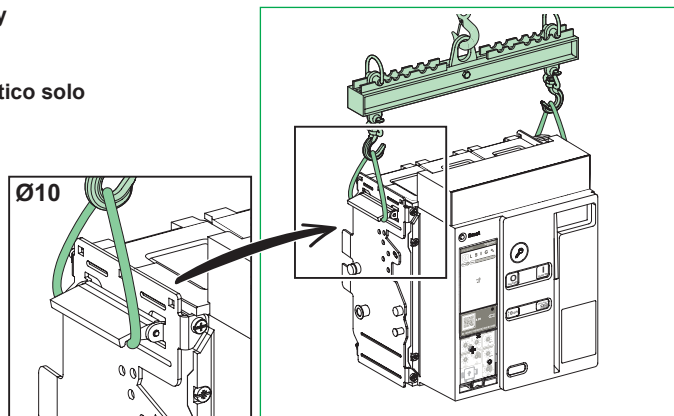

Circuit breaker only  
仅断路器  
Disjoncteur seul  
Interruptor automático solo  
Somente disjuntor

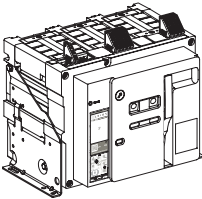
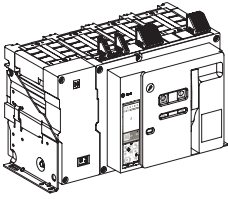
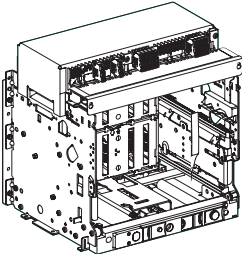
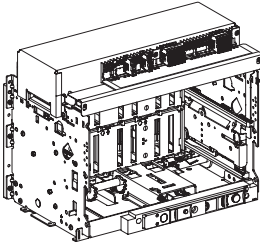
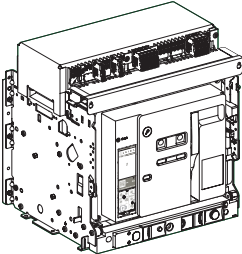
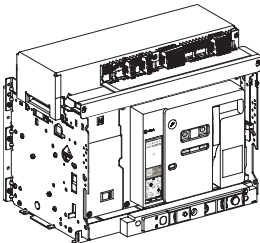

3P	 /kg	4P	 /kg
	≤ 50 kg		≤ 65 kg
	≤ 40 kg		≤ 55 kg
	≤ 90 kg		≤ 120 kg

# MVS2: Handling / 搬运 / Manutention / Transport / Manuseio

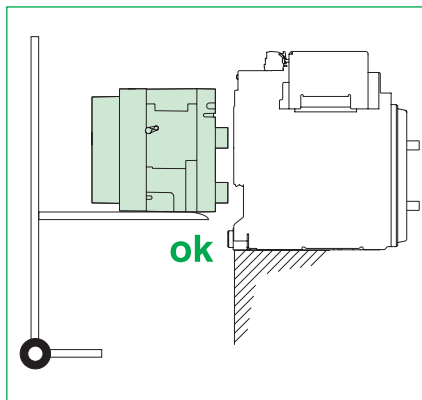
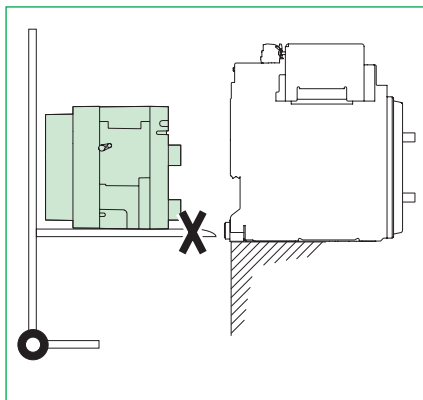
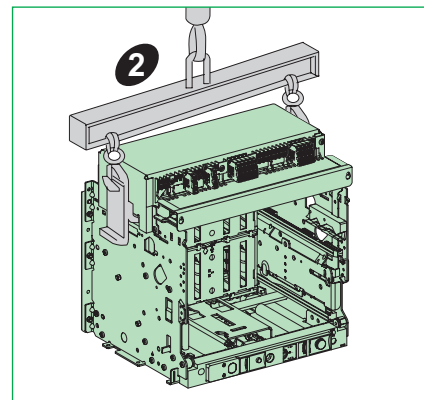
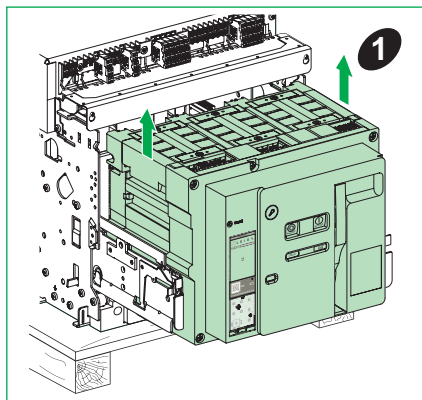
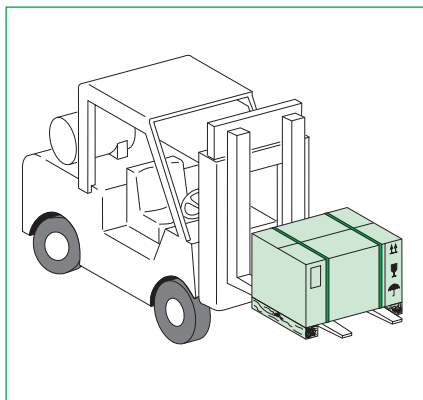

**MVS2: Handling / 搬运 / Manutention / Transport / Manuseio**

Chassis only  
仅抽架  
Châssis seul  
Chassis solo  
Somente chassis

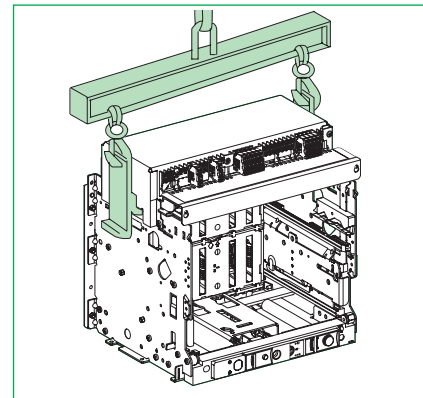
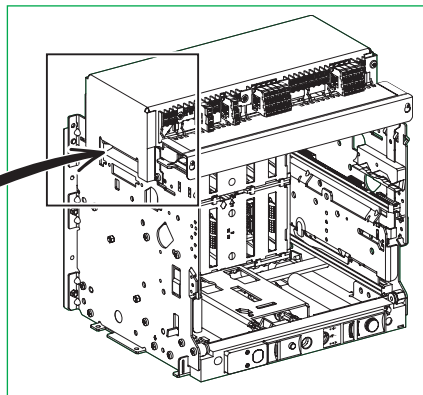
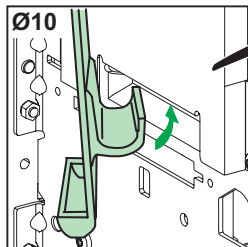

Circuit breaker only  
仅断路器  
Disjoncteur seul  
Interruptor automático solo  
Somente disjuntor

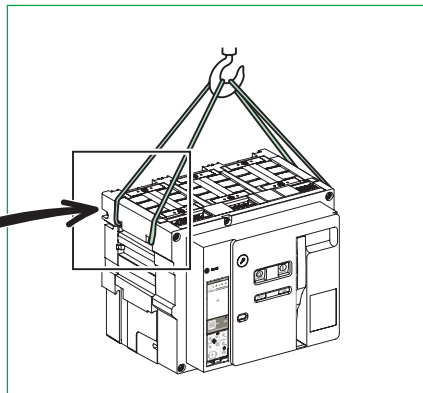
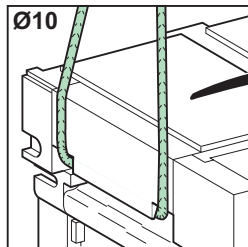

# MVS1: Installation / 安装 / Installation / Instalación / Instalação

## Fixed circuit breaker / 固定式断路器 / Disjoncteur fixe / Interruptor automático fijo / Disjuntor fixo

### Fixing / 固定 / Fixation / Fijación / Fixação

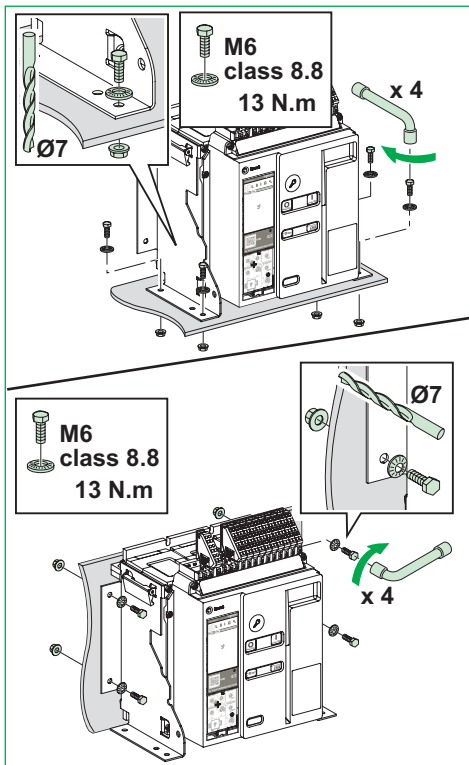

### Power Connections / 扩展端子 / Raccordement puissance / Conexión potencia / Conexões de energia

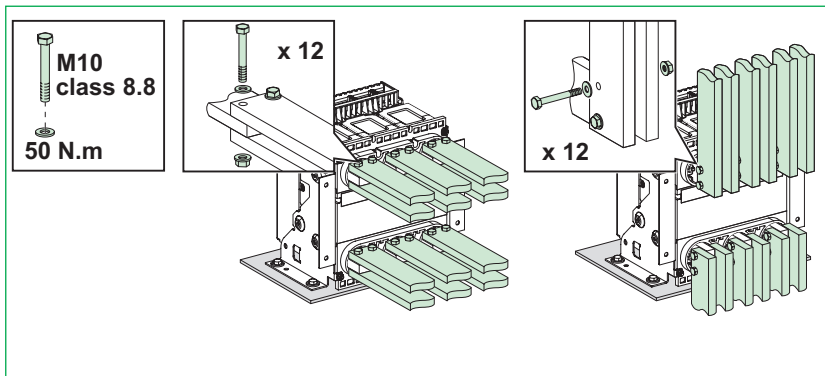

# MVS1: Installation / 安装 / Installation / Instalación / Instalação

Chassis only / 仅抽架 / Châssis seul / Chasis solo / Somente chassis

Fixing / 固定 / Fixation / Fijación / Fixação

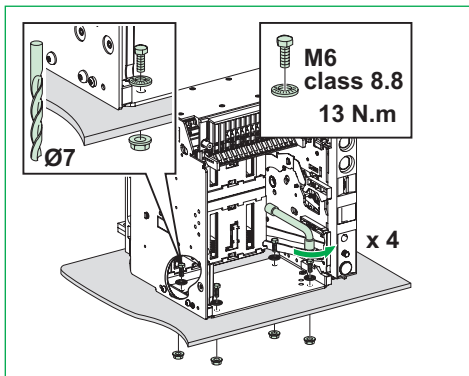

Power Connections / 扩展端子 / Raccordement puissance / Conexión potencia /  
Conexões de energia

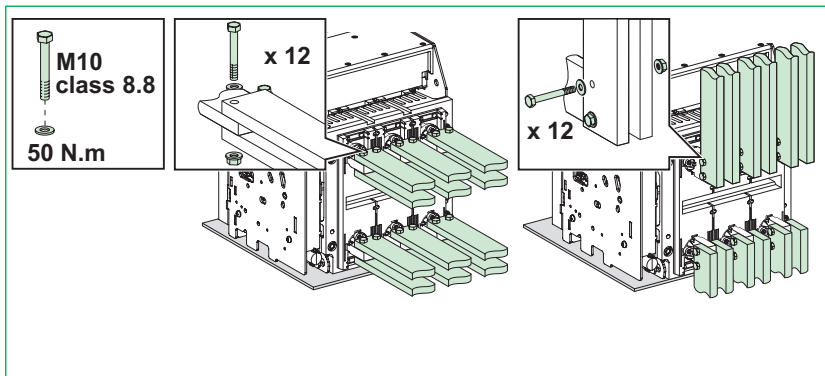

## MVS2: Installation / 安装 / Installation / Instalación / Instalação

### Fixed circuit breaker / 固定式断路器 / Disjoncteur fixe / Interruptor automático fijo / Disjuntor fixo

#### Fixing / 固定 / Fixation / Fijación / Fixação

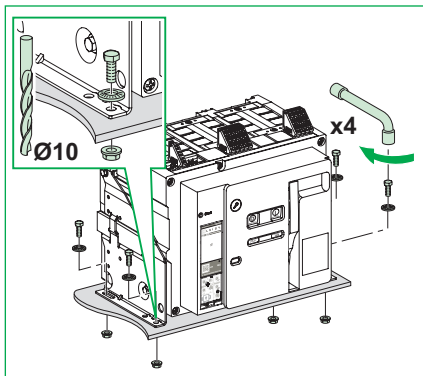

#### Power Connections / 扩展端子 / Raccordement puissance / Conexión potencia / Conexões de energia

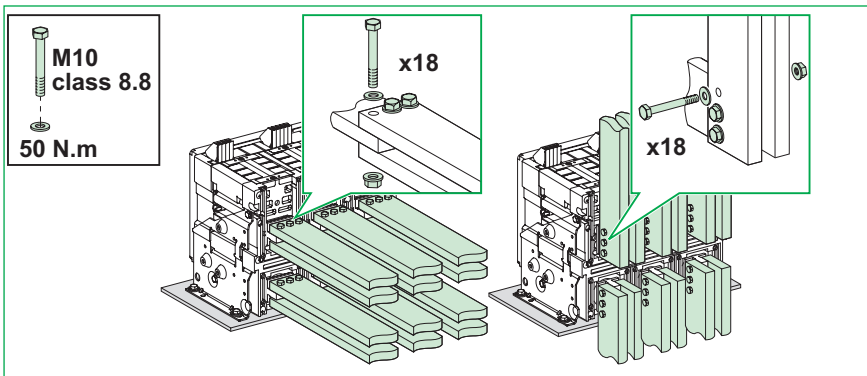

# MVS2: Installation / 安装 / Installation / Instalación / Instalação

Chassis only / 仅抽架 / Châssis seul / Chasis solo / Somente chassis

Fixing / 固定 / Fixation / Fijación / Fixação

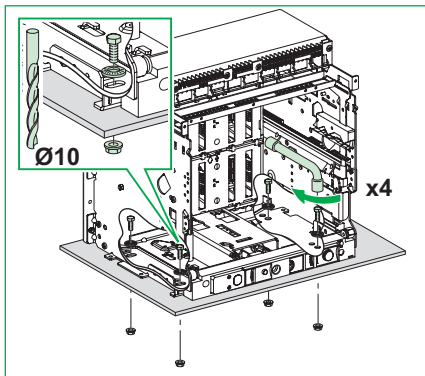

Power Connections / 扩展端子 / Raccordement puissance / Conexión potencia /  
Conexões de energia

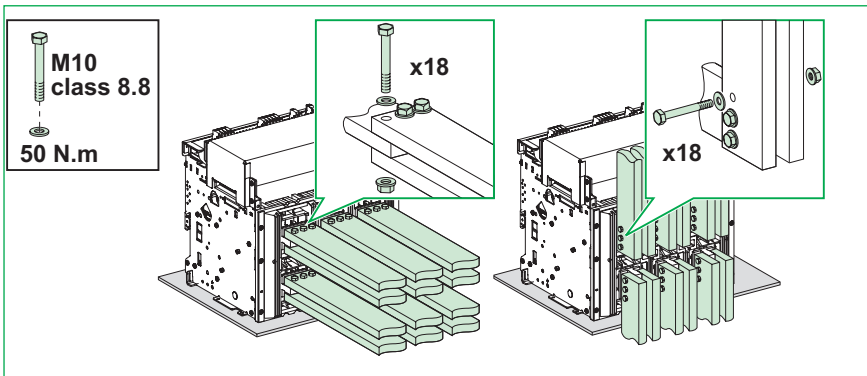

# MVS1: Clearance Distances / 间距 / Distances d'isolement / Distancias de separación / Distâncias de folga

## ⚠️ ⚠️ DANGER / 危險 / DANGER / PELIGRO / PERIGO

### HAZARD OF ELECTRIC SHOCK, EXPLOSION OR ARC FLASH

Clearance distances requirements must be met for proper operation of the equipment.

**Failure to follow these instructions will result in death or serious injury.**

**电击、爆炸或弧闪的危险**  
 为确保设备正常工作，必须满足安全间隙要求。  
**未按说明操作将导致人身伤亡等严重后果。**

### RISQUE D'ÉLECTROCUTION, D'EXPLOSION OU ÉCLAIR D'ARC ÉLECTRIQUE

Les distances de dégagement requises doivent être respectées pour assurer le bon fonctionnement de l'équipement.

**Le fait de ne pas suivre ces instructions entrainera des blessures graves, voire mortelles.**

### PELIGRO DE DESCARGA ELÉCTRICA, EXPLOSIÓN O DESTELLO POR ARQUEO

Es necesario cumplir los requisitos de distancia de seguridad para que el equipo funcione correctamente.

**El incumplimiento de estas instrucciones tendrá como resultado la muerte o lesiones graves.**

### RISCO DE ELECTROCUSSÃO, DE EXPLOSIÃO, OU DE ARCO ELÉCTRICO

Os requisitos de distâncias de distância devem ser cumpridos para o funcionamento correto do equipamento.

**O não cumprimento destas instruções resultará em morte e lesões graves.**

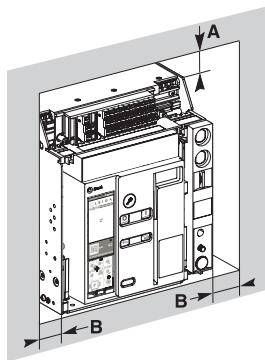
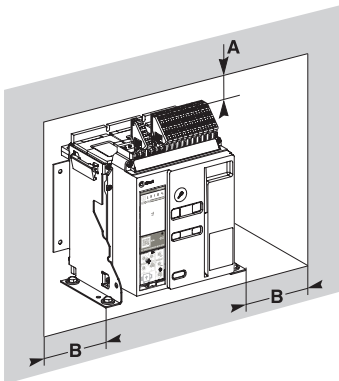

Parts / 部件 /  
 Pièces / Piezas /  
 Peças  
 (mm)

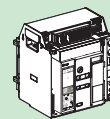

Insulated / 绝缘部件 /  
 Isolées / Aisladas /  
 Isolado

	A	B	A	B
Insulated / 绝缘部件 / Isolées / Aisladas / Isolado	0	0	0	10

Metal. / 金属部分 /  
 Métal. / Metálicas /  
 Metal

Metal. / 金属部分 / Métal. / Metálicas / Metal	0	0	0	10
--	---	---	---	----

Live / 带电部分 / Sous  
 tension / Bajo tensión  
 / Activo

Live / 带电部分 / Sous tension / Bajo tensión / Activo	100	60	30	60
--	-----	----	----	----

# MVS2: Clearance Distances / 间距 / Distances d'isolement / Distancias de separación / Distâncias de folga

## ⚠️ ⚠️ DANGER / 危險 / DANGER / PELIGRO / PERIGO

### HAZARD OF ELECTRIC SHOCK, EXPLOSION OR ARC FLASH

Clearance distances requirements must be met for proper operation of the equipment.

**Failure to follow these instructions will result in death or serious injury.**

**电击、爆炸或弧闪的危险**  
为确保设备正常工作，必须满足安全间隙要求。  
**未按说明操作将导致人身伤亡等严重后果。**

### RISQUE D'ÉLECTROCUTION, D'EXPLOSION OU ÉCLAIR D'ARC ÉLECTRIQUE

Les distances de dégagement requises doivent être respectées pour assurer le bon fonctionnement de l'équipement.

**Le fait de ne pas suivre ces instructions entrainera des blessures graves, voire mortelles.**

### PELIGRO DE DESCARGA ELÉCTRICA, EXPLOSIÓN O DESTELLO POR ARQUEO

Es necesario cumplir los requisitos de distancia de seguridad para que el equipo funcione correctamente.

**El incumplimiento de estas instrucciones tendrá como resultado la muerte o lesiones graves.**

### RISCO DE ELECTROCUSSÃO, DE EXPLOSIÃO, OU DE ARCO ELÉCTRICO

Os requisitos de distâncias de distância devem ser cumpridos para o funcionamento correto do equipamento.

**O não cumprimento destas instruções resultará em morte e lesões graves.**

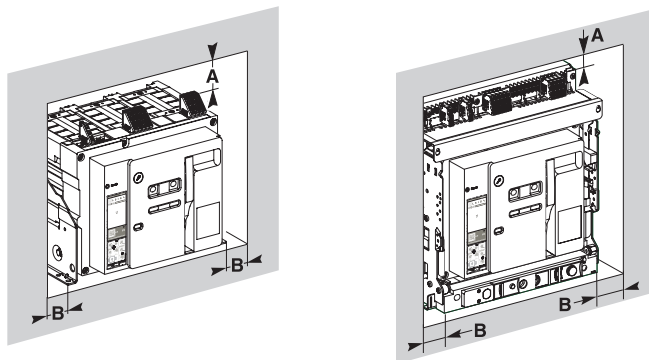

Parts / 部件 /  
Pièces / Piezas /  
Peças  
(mm)

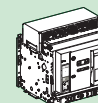

	A		B	
Insulated / 绝缘部件 / Isolées / Aisladas / Isolado	0	0	0	0
Metal. / 金属部分 / Métal. / Metálicas / Metal	0	0	0	0
Live / 带电部分 / Sous tension / Bajo tensión / Activo	100	60	60	60

**NOTICE / 注意 / AVIS / AVISO / AVISO**

**RISK OF OVERHEATING**

For MVS, do not use Aluminum (Al) power connections when Copper (Cu) power connections are required. **Failure to follow these instructions can result in equipment damage.**

**过热风险**

对于 MVS, 在需要连接铜 (Cu) 电源时, 请勿使用铝 (Al) 母排连接。 **不遵循上述说明可能导致设备损坏。**

**RISQUE DE SURCHAUFFE**

Pour MVS, n'utilisez pas de raccords d'alimentation en aluminium (Al) lorsque des raccords d'alimentation en cuivre (Cu) sont requis. **Le fait de ne pas suivre ces instructions peut endommager l'équipement.**

**RIESGO DE SOBRECALENTAMIENTO**

Para MVS, no utilice conexiones de alimentación de aluminio (Al) cuando se requieran conexiones de alimentación de cobre (Cu). **El incumplimiento de estas instrucciones podría provocar daños en el equipo.**

**RISCO DE SOBREAQUECIMENTO**

Para MVS, não use ligações de alimentação de Alumínio (Al) se forem necessárias ligações de alimentação de Cobre (Cu). **O não cumprimento destas instruções pode resultar em danos no equipamento.**

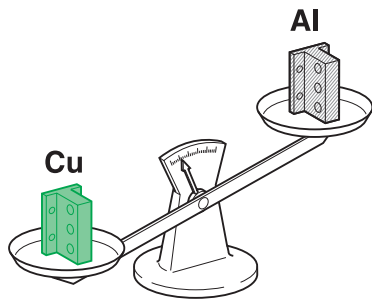

			630 A	800 A 1000 A 1250 A	1600 A	2000 A	2500 A 3200 A	4000 A
MVS1		C CA N1b N1bA				-	-	-
						-	-	-
MVS2		N NA H HA T	-					
		N NA H HA	-					-

# MVS1: Power Connections / 扩展端子 / Raccordement puissance / Conexión potencia / Conexões de energia

Drawout circuit breaker with chassis / 抽出式断路器 / Disjoncteur débrochable avec châssis / Interruptor automático seccionable con chasis / Disjuntor extraível com chassis

## ⚠ ⚠ DANGER / 危险 / DANGER / PELIGRO / PERIGO

### HAZARD OF FLASHOVER BETWEEN POLARITIES

Interphase barriers must be installed if the MVS1 network voltage is greater than or equal to 500 V $\sim$ .

**Failure to follow these instructions will result in death or serious injury.**

### 电极之间的飞弧危险

对于 MVS1, 如果网络电压大于或等于 500 V $\sim$ , 则必须安装相间隔板。

**未按说明操作将导致人身伤亡等严重后果。**

### RISQUE D'ÉTINCELLE DE RUPTURE ENTRE LES POLARITÉS

Des séparateurs de phases doivent être installés si la tension réseau MVS1 est supérieure ou égale à 500 V $\sim$ .

**Le fait de ne pas suivre ces instructions entrainera des blessures graves, voire mortelles.**

### PELIGRO DE ARCO ELÉCTRICO ENTRE POLARIDADES

Las barreras interfásicas deben instalarse si el voltaje de la red MVS1 es mayor o igual a 500 V $\sim$ .

**El incumplimiento de estas instrucciones tendrá como resultado la muerte o lesiones graves.**

### RISCO DE DESCARGA ELÉTRICA ENTRE POLARIDADES

As barreiras interfásicas devem ser instaladas se a tensão de rede MVS1 for igual ou superior a 500 V $\sim$ .

**O não cumprimento destas instruções resultará em morte e lesões graves.**

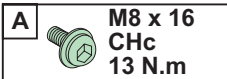
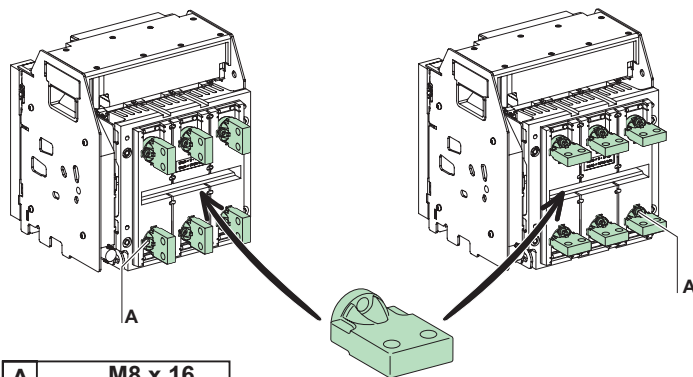

MVS1: Power Connections / 扩展端子 / Raccordement puissance / Conexión potencia /  
 Conexões de energia

Drawout circuit breaker with chassis / 抽出式断路器 / Disjoncteur débrochable avec châssis /  
 Interruptor automático seccionable con chasis / Disjuntor extraível com chasis

**⚠ ⚠ DANGER / 危险 / DANGER / PELIGRO / PERIGO**

**HAZARD OF FLASHOVER BETWEEN POLARITIES**  
 Interphase barriers must be installed if the MVS1 network voltage is greater than or equal to 500 V~.  
**Failure to follow these instructions will result in death or serious injury.**

**电极之间的飞弧危险**  
 对于 MVS1, 如果网络电压大于或等于 500 V~, 则必须安装相间隔板。  
**未按说明操作将导致人身伤亡等严重后果。**

**RISQUE D'ÉTINCELLE DE RUPTURE ENTRE LES POLARITÉS**  
 Des séparateurs de phases doivent être installés si la tension réseau MVS1 est supérieure ou égale à 500 V~.  
**Le fait de ne pas suivre ces instructions entraînera des blessures graves, voire mortelles.**

**PELIGRO DE ARCO ELÉCTRICO ENTRE POLARIDADES**  
 Las barreras interfásicas deben instalarse si el voltaje de la red MVS1 es mayor o igual a 500 V~.  
**El incumplimiento de estas instrucciones tendrá como resultado la muerte o lesiones graves.**

**RISCO DE DESCARGA ELÉTRICA ENTRE POLARIDADES**  
 As barreiras interfásicas devem ser instaladas se a tensão de rede MVS1 for igual ou superior a 500 V~.  
**O não cumprimento destas instruções resultará em morte e lesões graves.**

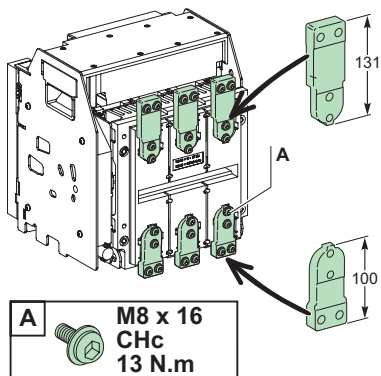

# MVS1: Power Connections / 扩展端子 / Raccordement puissance / Conexión potencia / Conexões de energia

Fixed circuit breaker / 固定式断路器 / Disjoncteur fixe / Interruptor automático fijo / Disjuntor fixo

## ⚠ ⚠ DANGER / 危险 / DANGER / PELIGRO / PERIGO

### HAZARD OF FLASHOVER BETWEEN POLARITIES

Interphase barriers must be installed if the MVS1 network voltage is greater than or equal to 500 V~.

**Failure to follow these instructions will result in death or serious injury.**

### 电极之间的飞弧危险

对于 MVS1, 如果网络电压大于或等于 500 V~, 则必须安装相间隔板。

**未按说明操作将导致人身伤亡等严重后果。**

### RISQUE D'ÉTINCELLE DE RUPTURE ENTRE LES POLARITÉS

Des séparateurs de phases doivent être installés si la tension réseau MVS1 est supérieure ou égale à 500 V~.

**Le fait de ne pas suivre ces instructions entraînera des blessures graves, voire mortelles.**

### PELIGRO DE ARCO ELÉCTRICO ENTRE POLARIDADES

Las barreras interfásicas deben instalarse si el voltaje de la red MVS1 es mayor o igual a 500 V~.

**El incumplimiento de estas instrucciones tendrá como resultado la muerte o lesiones graves.**

### RISCO DE DESCARGA ELÉTRICA ENTRE POLARIDADES

As barreiras interfásicas devem ser instaladas se a tensão de rede MVS1 for igual ou superior a 500 V~.

**O não cumprimento destas instruções resultará em morte e lesões graves.**

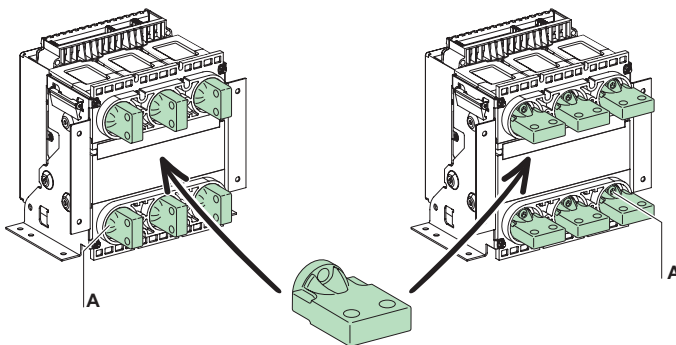

**A** M8 x 16  
CHc  
13 N.m

MVS1: Power Connections / 扩展端子 / Raccordement puissance / Conexión potencia /  
 Conexões de energia

Fixed circuit breaker / 固定式断路器 / Disjoncteur fixe / Interruptor automático fijo / Disjuntor fixo

**⚠ ⚠ DANGER / 危险 / DANGER / PELIGRO / PERIGO**

**HAZARD OF FLASHOVER BETWEEN POLARITIES**

Interphase barriers must be installed if the MVS1 network voltage is greater than or equal to 500 V~.

**Failure to follow these instructions will result in death or serious injury.**

**电极之间的飞弧危险**  
 对于 MVS1, 如果网络电压大于或等于 500 V~, 则必须安装相间隔板。  
**未按说明操作将导致人身伤亡等严重后果。**

**RISQUE D'ÉTINCELLE DE RUPTURE ENTRE LES POLARITÉS**

Des séparateurs de phases doivent être installés si la tension réseau MVS1 est supérieure ou égale à 500 V~.

**Le fait de ne pas suivre ces instructions entrainera des blessures graves, voire mortelles.**

**PELIGRO DE ARCO ELÉCTRICO ENTRE POLARIDADES**

Las barreras interfásicas deben instalarse si el voltaje de la red MVS1 es mayor o igual a 500 V~.

**El incumplimiento de estas instrucciones tendrá como resultado la muerte o lesiones graves.**

**RISCO DE DESCARGA ELÉTRICA ENTRE POLARIDADES**

As barreiras interfásicas devem ser instaladas se a tensão de rede MVS1 for igual ou superior a 500 V~.

**O não cumprimento destas instruções resultará em morte e lesões graves.**

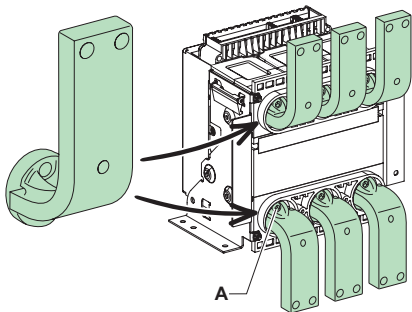

**A** M8 x 16  
 CHc  
 13 N.m

# MVS2: Power Connections / 扩展端子 / Raccordement puissance / Conexión potencia / Conexões de energia

Drawout circuit breaker with chassis / 抽出式断路器 / Disjoncteur débrochable avec châssis /  
Interruptor automático seccionable con chasis / Disjuntor extraível com chasis

## MVS08-MVS32

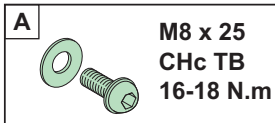
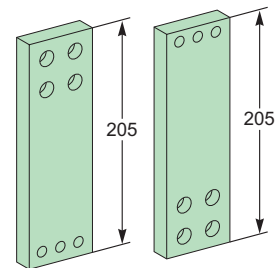
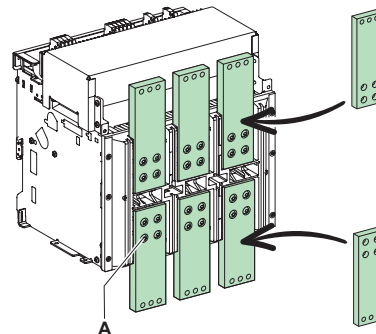
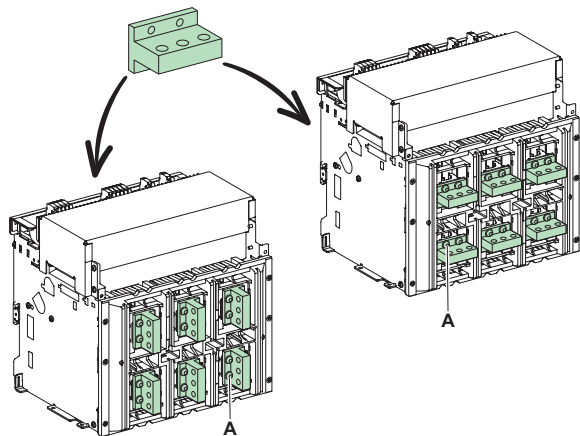

**MVS2: Power Connections / 扩展端子 / Raccordement puissance / Conexión potencia / Conexões de energia**

**Drawout circuit breaker with chassis / 抽出式断路器 / Disjoncteur débrochable avec châssis / Interruptor automático seccionable con chasis / Disjuntor extraível com chasis**

**MVS40**

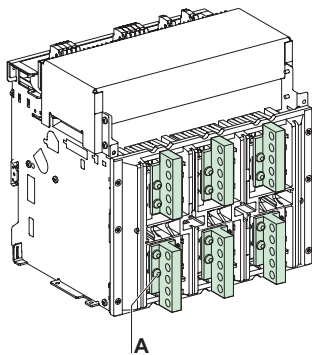

**4P**

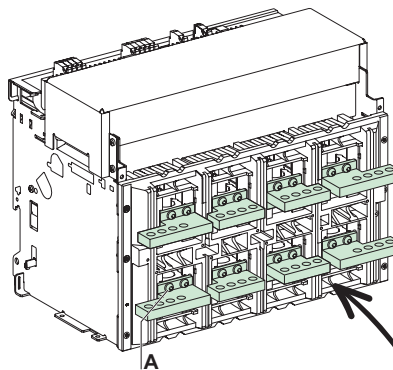

**3P**

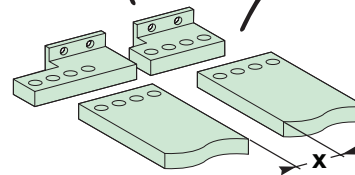
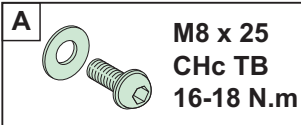
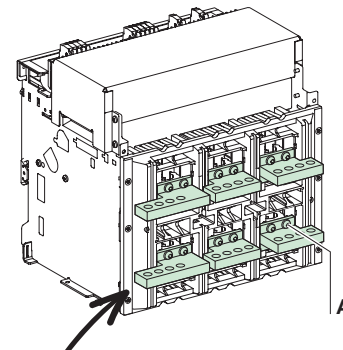

<b>Ui</b>	<b>X mini</b>
600 V	8 mm
1000 V	14 mm

## MVS2: Power Connections / 扩展端子 / Raccordement puissance / Conexión potencia / Conexões de energia

Fixed circuit breaker / 固定式断路器 / Disjoncteur fixe / Interruptor automático fijo / Disjuntor fixo

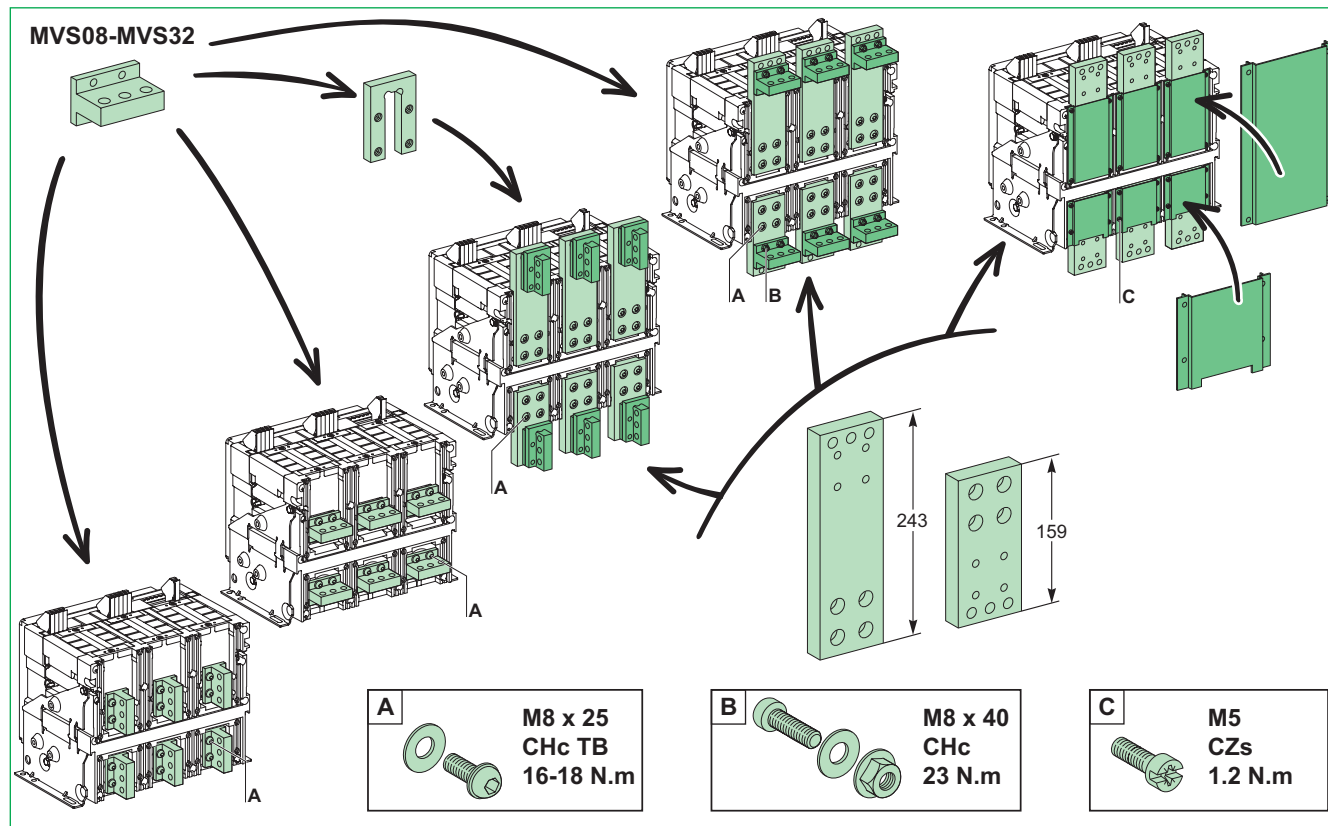

MVS2: Power Connections / 扩展端子 / Raccordement puissance / Conexión potencia /  
 Conexões de energia

Fixed circuit breaker / 固定式断路器 / Disjoncteur fixe / Interruptor automático fijo / Disjuntor fixo

MVS40

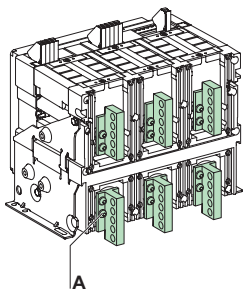

4P

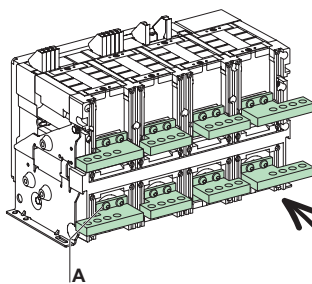

3P

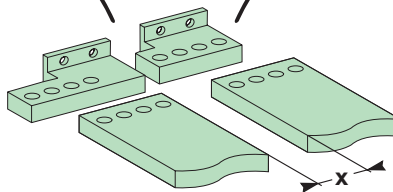
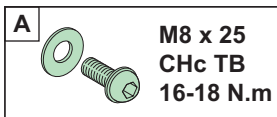
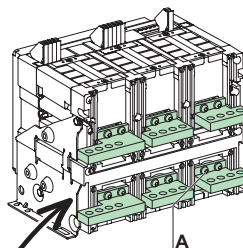

Ui	X mini
600 V	8 mm
1000 V	14 mm

## MVS1: Interphase Barriers / 相间隔板 / Séparateurs de phases / Barreras interfásicas / Barreiras interfásicas

Drawout circuit breaker with chassis / 抽出式断路器 / Disjoncteur débrochable avec châssis / Interruptor automático seccionable con chasis / Disjuntor extraível com chassís

### ⚠ ⚠ DANGER / 危险 / DANGER / PELIGRO / PERIGO

#### HAZARD OF FLASHOVER BETWEEN POLARITIES

Interphase barriers must be installed if the MVS1 network voltage is greater than or equal to 500 V~.

**Failure to follow these instructions will result in death or serious injury.**

**电极之间的飞弧危险**  
对于 MVS1, 如果网络电压大于或等于 500 V~, 则必须安装相间隔板。  
**未按说明操作将导致人身伤亡等严重后果。**

#### RISQUE D'ÉTINCELLE DE RUPTURE ENTRE LES POLARITÉS

Des séparateurs de phases doivent être installés si la tension réseau MVS1 est supérieure ou égale à 500 V~.

**Le fait de ne pas suivre ces instructions entraînera des blessures graves, voire mortelles.**

#### PELIGRO DE ARCO ELÉCTRICO ENTRE POLARIDADES

Las barreras interfásicas deben instalarse si el voltaje de la red MVS1 es mayor o igual a 500 V~.

**El incumplimiento de estas instrucciones tendrá como resultado la muerte o lesiones graves.**

#### RISCO DE DESCARGA ELÉTRICA ENTRE POLARIDADES

As barreiras interfásicas devem ser instaladas se a tensão de rede MVS1 for igual ou superior a 500 V~.

**O não cumprimento destas instruções resultará em morte e lesões graves.**

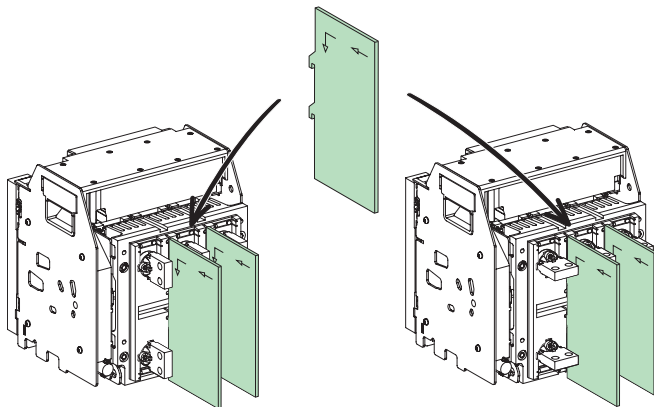

# MVS1: Interphase Barriers / 相间隔板 / Séparateurs de phases / Barreras interfásicas / Barreiras interfásicas

Fixed circuit breaker / 固定式断路器 / Disjoncteur fixe / Interruptor automático fijo / Disjuntor fixo

## ⚠ ⚠ DANGER / 危險 / DANGER / PELIGRO / PERIGO

### HAZARD OF FLASHOVER BETWEEN POLARITIES

Interphase barriers must be installed if the MVS1 network voltage is greater than or equal to 500 V~.

Failure to follow these instructions will result in death or serious injury.

### 电极之间的飞弧危险

对于 MVS1, 如果网络电压大于或等于 500 V~, 则必须安装相间隔板。  
未按说明操作将导致人身伤亡等严重后果。

### RISQUE D'ÉTINCELLE DE RUPTURE ENTRE LES POLARITÉS

Des séparateurs de phases doivent être installés si la tension réseau MVS1 est supérieure ou égale à 500 V~.

Le fait de ne pas suivre ces instructions entrainera des blessures graves, voire mortelles.

### PELIGRO DE ARCO ELÉCTRICO ENTRE POLARIDADES

Las barreras interfásicas deben instalarse si el voltaje de la red MVS1 es mayor o igual a 500 V~.

El incumplimiento de estas instrucciones tendrá como resultado la muerte o lesiones graves.

### RISCO DE DESCARGA ELÉTRICA ENTRE POLARIDADES

As barreiras interfásicas devem ser instaladas se a tensão de rede MVS1 for igual ou superior a 500 V~.

O não cumprimento destas instruções resultará em morte e lesões graves.

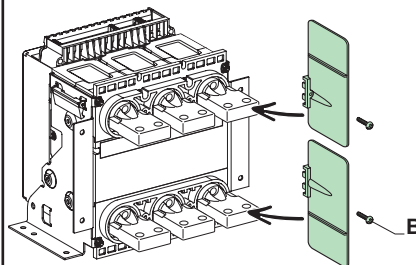
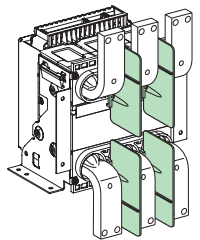
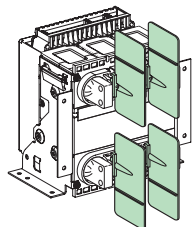
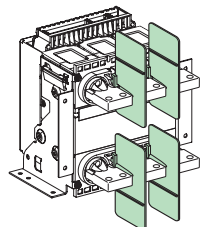

OR  
或  
OU  
O  
OU

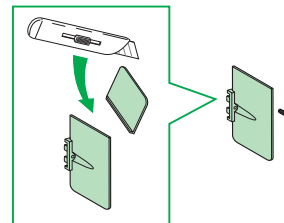

B Ø4 x 20  
1.5 N.m

## MVS2: Interphase Barriers / 相间隔板 / Séparateurs de phases / Barreras interfásicas / Barreiras interfásicas

Drawout circuit breaker with chassis / 抽出式断路器 / Disjoncteur débrochable avec châssis /  
Interruptor automático seccionable con chasis / Disjuntor extraível com chasis

### MVS08-MVS32

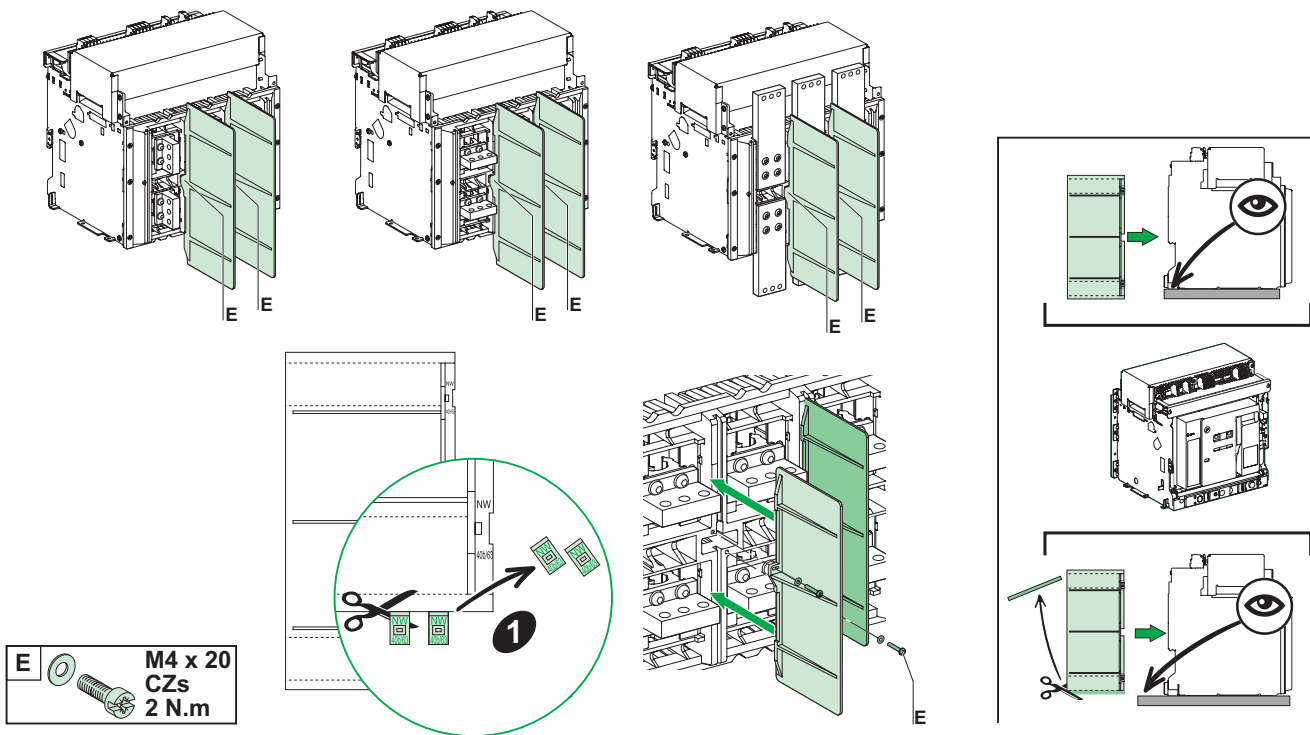

# MVS2: Interphase Barriers / 相间隔板 / Séparateurs de phases / Barreras interfásicas / Barreiras interfásicas

Drawout circuit breaker with chassis / 抽出式断路器 / Disjoncteur débrochable avec châssis / Interruptor automático seccionable con chasis / Disjuntor extraível com chasis

MVS40

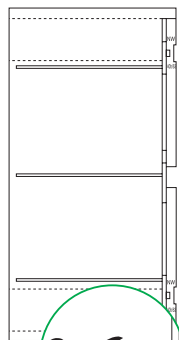
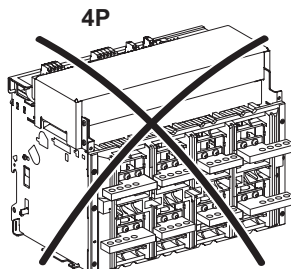
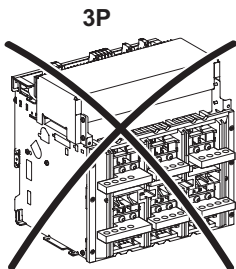
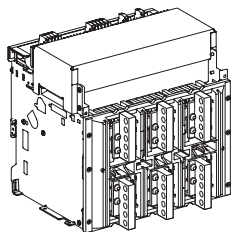

1

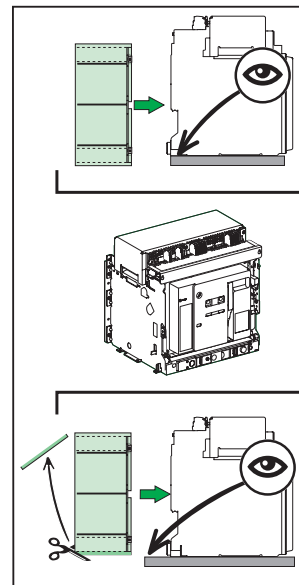
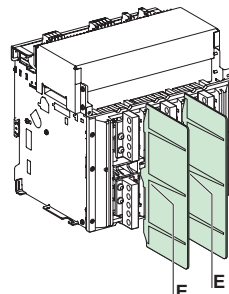

## MVS2: Interphase Barriers / 相间隔板 / Séparateurs de phases / Barreras interfásicas / Barreiras interfásicas

Fixed circuit breaker / 固定式断路器 / Disjoncteur fixe / Interruptor automático fijo / Disjuntor fijo

**MVS08-MVS32**

**1**

**D** M5 x 16  
CZs  
1.4 N.m

**E** M4 x 20  
CZs  
2 N.m

# MVS2: Interphase Barriers / 相间隔板 / Séparateurs de phases / Barreras interfásicas / Barreiras interfásicas

Fixed circuit breaker / 固定式断路器 / Disjoncteur fixe / Interruptor automático fijo / Disjuntor fixo

## MVS40

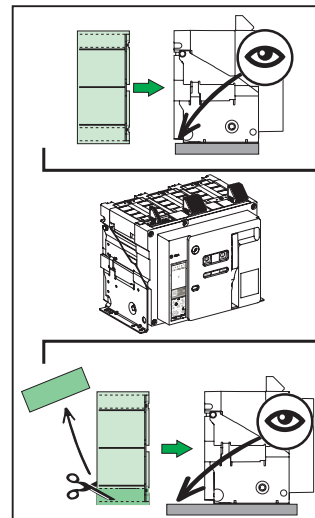
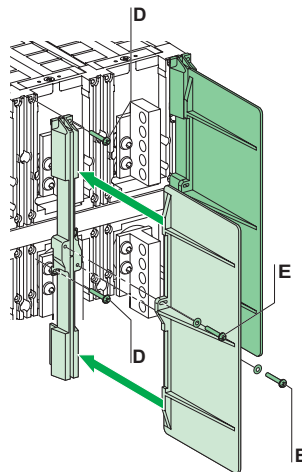
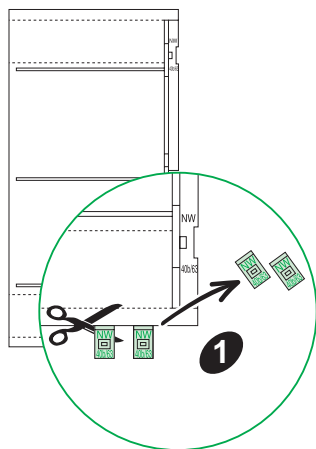
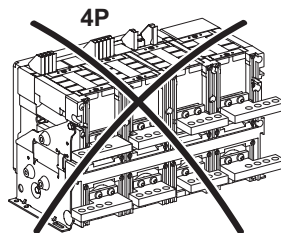
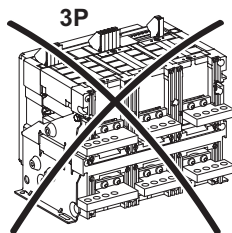
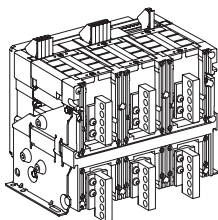

## Auxiliary Connections / 辅助连接 / Raccordement auxiliaire / Conexión auxiliar / Conexões auxiliares

<p><b>(EN)</b> The maximum voltage connected to the terminal block is:</p> <ul style="list-style-type: none"> <li>● 690 V~ simple insulation between adjacent terminals.</li> <li>● 480 V~ double insulation between adjacent terminals.</li> </ul>	<p><b>(ZH)</b> 连接到端子块的最大电压为:</p> <ul style="list-style-type: none"> <li>● 690 V~ 相邻端子之间满足基本绝缘。</li> <li>● 480 V~ 相邻端子之间满足 双重绝缘。</li> </ul>	<p><b>(FR)</b> La tension maximum connectée au bornier est:</p> <ul style="list-style-type: none"> <li>● 690 V~ isolation simple entre bornes adjacentes.</li> <li>● 480 V~ isolation double entre bornes adjacentes.</li> </ul>	<p><b>(ES)</b> El voltaje máximo conectado al bloque de terminales es:</p> <ul style="list-style-type: none"> <li>● 690 V~ de aislamiento simple entre terminales adyacentes.</li> <li>● 480 V~ de aislamiento doble entre terminales adyacentes.</li> </ul>	<p><b>(PT)</b> A tensão máxima ligada ao bloco terminal é:</p> <ul style="list-style-type: none"> <li>● Isolamento simples de 690 V~ entre terminais adjacentes.</li> <li>● Isolamento duplo de 480 V~ entre terminais adjacentes.</li> </ul>
---	--	--	--	---

### **⚠ ⚠ DANGER / 危险 / DANGER / PELIGRO / PERIGO**

<p><b>HAZARD OF ELECTROCUTION FOR VOLTAGES ABOVE 480 V~</b> If a voltage greater than 480 V~ is connected to a terminal, it is forbidden to connect adjacent terminals to a 24 V~ SELV (Safety Extra Low Voltage) power supply in order to observe the insulation distances. <b>Failure to follow these instructions will result in death or serious injury.</b></p>	<p><b>电压超过 480 V~ 时有电击的危险</b> 如果连接到端子的电压高于 480 V~, 则禁止将相邻端子连接到 24 V~ SELV (安全特低电压) 电源, 以便达到绝缘距离要求。 <b>未按说明操作将导致人身伤亡等严重后果。</b></p>	<p><b>RISQUE D'ÉLECTROCUTION POUR LES TENSIONS SUPÉRIEURES À 480 V~</b> Si une tension supérieure à 480 V~ est connectée à une borne, il est interdit de raccorder les bornes adjacentes à une alimentation TBTS (très basse tension de sécurité) 24 V~ afin de respecter les distances d'isolement. <b>Le fait de ne pas suivre ces instructions entraînera des blessures graves, voire mortelles.</b></p>	<p><b>PELIGRO DE ELECTROCUCIÓN PARA VOLTAJES SUPERIORES A 480 V~</b> Si se conecta a un terminal un voltaje superior a 480 V~, está prohibido conectar terminales adyacentes a un terminal de 24 V~ de fuente de alimentación SELV (Intensidad Extra Baja de Seguridad) para cumplir con las distancias de aislamiento. <b>El incumplimiento de estas instrucciones tendrá como resultado la muerte o lesiones graves.</b></p>	<p><b>PERIGO DE ELETROCUSSÃO PARA TENSÕES SUPERIORES A 480 V~</b> Se uma tensão superior a 480 V~ estiver ligada a um terminal, é proibido ligar terminais adjacentes a um terminal de 24 V~ Fonte de alimentação SELV (baixa tensão de segurança) para respeitar as distâncias de isolamento. <b>O não cumprimento destas instruções resultará em morte e lesões graves.</b></p>
--	---	---	--	---

# MVS1: Auxiliary Connections / 辅助连接 / Raccordement auxiliaire / Conexión auxiliar / Conexões auxiliares

Chassis only / 仅限抽架 / Châssis seul / Chassis solo / Somente chassis

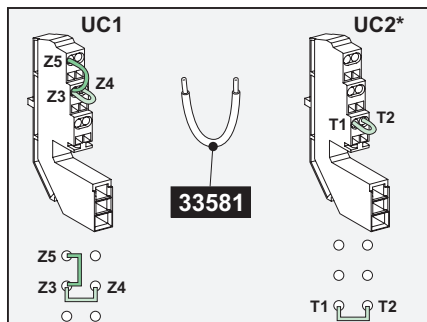

(\* Only applicable for 6.0S  
 仅适用于 TS 6.0S  
 Pour TS 6.0S uniquement  
 Solo se aplica a TS 6.0S  
 Apenas aplicável a TS 6.0S

Trip System	UC1	x 1
	UC2	x 1
COM		x 1
Trip System	UC3	x 1
	UC4	x 1
M2C		x 1
SDE1		x 1
MN		x 1
MX		x 1
XF		x 1
PF		x 1
MCH		x 1
OF1		x 1
OF2		x 1
OF3 (Optional)		x 1
OF4 (Optional)		x 1

47072

47071

Mounting / 安装 / Montage / Montaje / Montagem

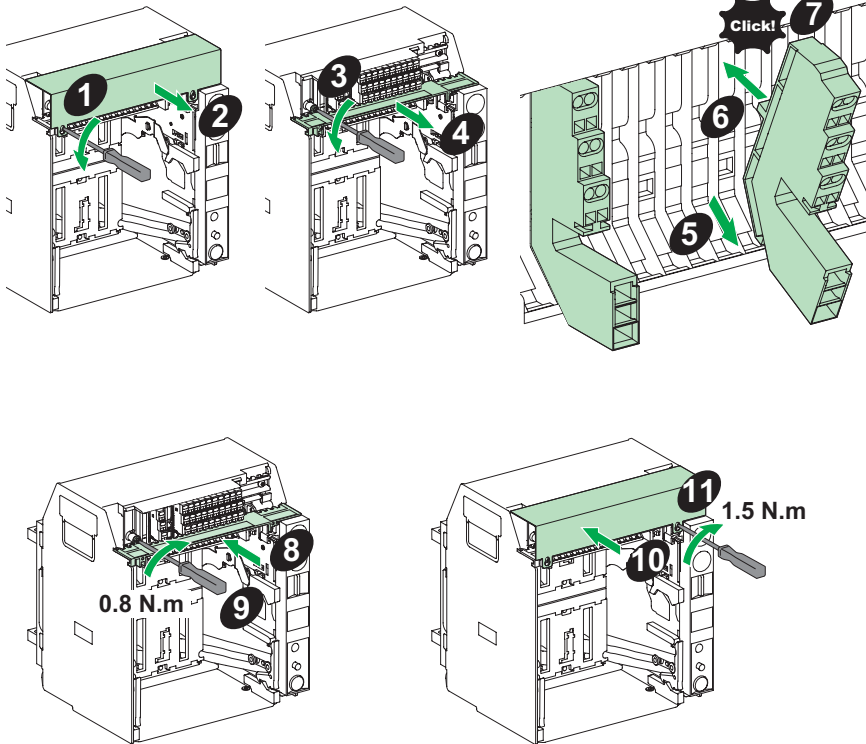

# MVS1: Auxiliary Connections / 辅助连接 / Raccordement auxiliaire / Conexión auxiliar / Conexões auxiliares

Cross-section of wires

线缆横截面

Section des fils

Sección de los hilos

Secção transversal dos fios

mini  S : 0.6 mm<sup>2</sup>

maxi  S : 2.5 mm<sup>2</sup>

Remove insulation

剥去绝缘层

Dénudez les fils

Pele los hilos

Remover isolamento

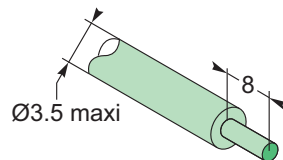

Chassis only / 仅限抽架 /  
Châssis seul / Chassis solo /  
Somente chassis

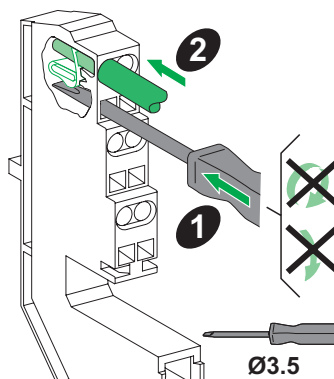

Fixed circuit breaker /  
固定式断路器 / Disjoncteur fixe /  
Interruptor automático fijo /  
Disjuntor fixo

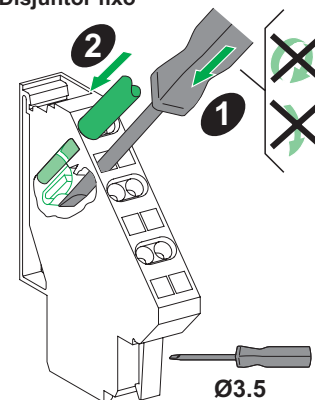

# MVS2: Auxiliary Connections / 辅助连接 / Raccordement auxiliaire / Conexión auxiliar / Conexões auxiliares

Chassis only / 仅限抽架 / Châssis seul /  
Chassis solo / Somente chassis

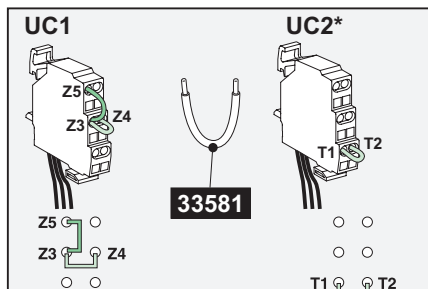



(\* ) Only applicable for 6.0S  
仅适用于 TS 6.0S  
Pour TS 6.0S uniquement  
Solo se aplica a TS 6.0S  
Apenas aplicável a TS 6.0S

Trip System	UC1	x 1		47850
	UC2	x 1		
COM		x 1		47849
Trip System	UC3	x 1		
	UC4	x 1		
M2C		x 1		
SDE1		x 1		
MN		x 1		
MX		x 1		
XF		x 1		
PF		x 1		
MCH		x 1		
OF1		x 1		
⋮		⋮		
OF24		x 1		

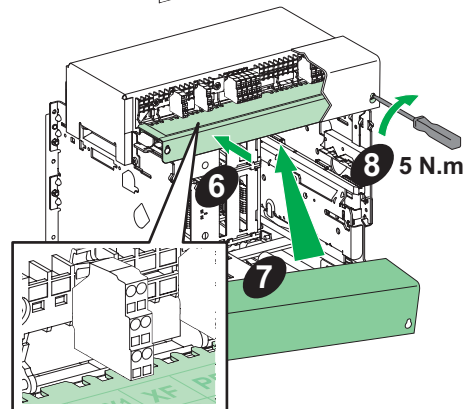
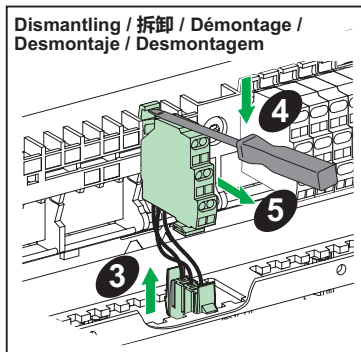
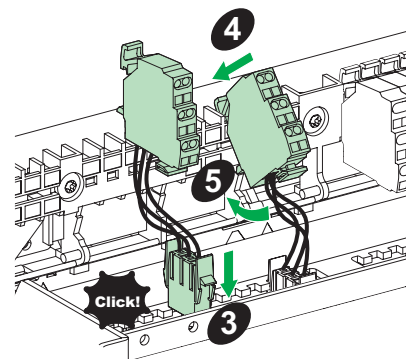
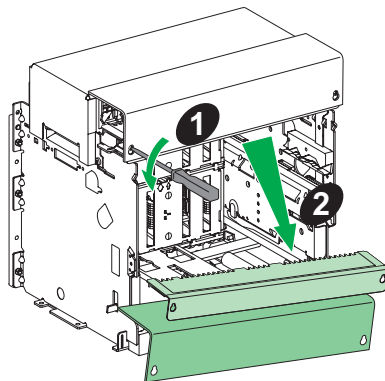
Mounting / 安装 / Montage / Montaje / Montagem

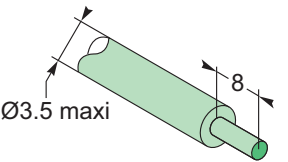
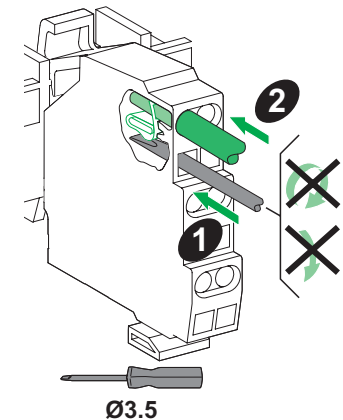
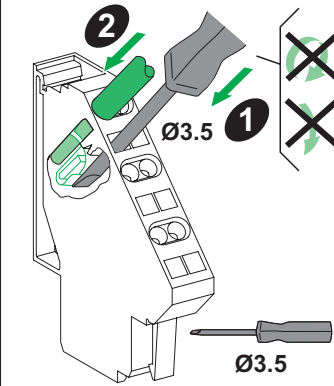

# MVS2: Auxiliary Connections / 辅助连接 / Raccordement auxiliaire / Conexión auxiliar / Conexões auxiliares

<p>Cross-section of wires 线缆横截面 Section des fils Sección de los hilos Secção transversal dos fios</p>	<p>mini  S : 0.6 mm<sup>2</sup> maxi  S : 2.5 mm<sup>2</sup></p>	<p>Chassis only / 仅限抽架 / Châssis seul / Chassis solo / Somente chassis</p>	<p>Fixed circuit breaker / 固定式断路器 / Disjoncteur fixe / Interruptor automático fijo / Disjuntor fixo</p>
<p>Remove insulation 剥去绝缘层 Dénudez les fils Pele los hilos Remover isolamento</p>			

**NOTICE / 注意 / AVIS / AVISO / AVISO**

<p><b>HAZARD OF DESTRUCTION OF THE TRIP UNIT OR ACCESSORIES</b> Respect the power supply ratings of accessories while connecting the customer's terminal block. <b>Failure to follow these instructions can result in equipment damage.</b></p>	<p><b>脱扣单元或附件损毁危险</b> 在连接客户的端子块时，应遵守附件电源额定值要求。 <b>不遵循上述说明可能导致设备损坏。</b></p>	<p><b>RISQUE DE DESTRUCTION DU DÉCLENCHEUR OU DES ACCESSOIRES</b> Respectez les caractéristiques nominales d'alimentation des accessoires lors du raccordement du bornier du client. <b>Le fait de ne pas suivre ces instructions peut endommager l'équipement.</b></p>	<p><b>PELIGRO DE DESTRUCCIÓN DE LA UNIDAD DE DISPARO O ACCESORIOS</b> Respete los valores nominales de alimentación de los accesorios al conectar el bloque de terminales del cliente. <b>El incumplimiento de estas instrucciones podría provocar daños en el equipo.</b></p>	<p><b>PERIGO DE DESTRUIÇÃO DA UNIDADE DE DISPARO OU ACESSÓRIOS</b> Respeite as potências de consumo dos acessórios quando efetuar as ligações ao bloco de terminais do cliente. <b>O não cumprimento destas instruções pode resultar em danos no equipamento.</b></p>
<p>Wiring diagram (page 57 and 58) shown with circuits deenergised, circuit breaker open and in connected position, spring charged and relays in released position.</p>	<p>电路图(第 57 和 58 页)显示电路不带电，断路器分闸并处于连接位置，弹簧已储能，继电器在释放位置。</p>	<p>Schéma de câblage (page 57 et 58) présenté avec circuits hors tension, disjoncteur ouvert et en position embroché, ressort d'accumulation d'énergie armé et relais ouverts.</p>	<p>Diagrama de cableado (páginas 57 y 58) que se muestra con los circuitos sin corriente, el interruptor automático abierto y en la posición de conectado, el resorte cargado y los relés en la posición de liberado.</p>	<p>Diagrama de cablagem (página 57 e 58) mostrado com circuitos desenergizados, disjuntor aberto e na posição ligada, mola carregada e relés na posição de libertação.</p>

### Control unit / 控制单元 / Unidad de control / Déclencheur / Unidade de controle

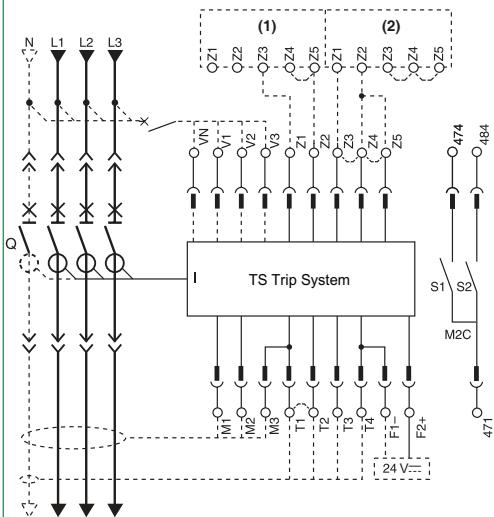

Com	UC1	UC2*	UC3	UC4	M2C
○ ○	○ ○	○ ○	○ ○	○ ○	○ ○
E5 E6	Z5 M1	M2 M3	F2+	Z5	484
○ ○	○ ○	○ ○	○ ○	○ ○	○ ○
E3 E4	Z3 Z4	T3 T4	VN	V2	474
○ ○	○ ○	○ ○	○ ○	○ ○	○ ○
E1 E2	Z1 Z2	T1 T2	F1-	V1	471

(\*) Only applicable for TS 6.0S  
 仅适用于 TS 6.0S  
 Pour TS 6.0S uniquement  
 Solo se aplica a TS 6.0S  
 Apenas aplicável a TS 6.0S

### Remote control / 远程操作 / Commande à distance / Mando a distancia / Controle remoto

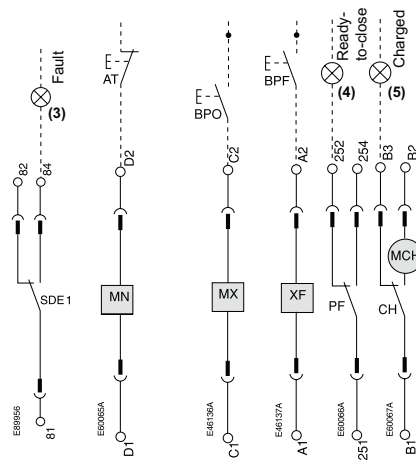

SDE1	MN	MX	XF	PF	MCH
○ ○	○ ○	○ ○	○ ○	○ ○	○ ○
84	D2	C2	A2	254	B2
○ ○	○ ○	○ ○	○ ○	○ ○	○ ○
82		C3	A3	252	B3
○ ○	○ ○	○ ○	○ ○	○ ○	○ ○
81	D1	C1	A1	251	B1

- (1) Upstream breaker / 上级 / Disjoncteur amont / Interruptor aguas arriba / Disjuntor a montante
- (2) Downstream breaker / 下级 / Disjoncteur aval / Interruptor aguas abajo / Disjuntor a jusante
- (3) Fault / 故障 / Défaut / Defecto / Falha
- (4) Ready to close / 合闸就绪 / Prêt à fermer / Preparado para cerrar / Pronto a fechar
- (5) Spring charged / 弹簧储能 / Ressort armé / Resorte cargado / Carga por mola

**Auxiliary switches / 辅助开关 / Contacts de signalisation / Contactos de señalización / Interruptores auxiliares**

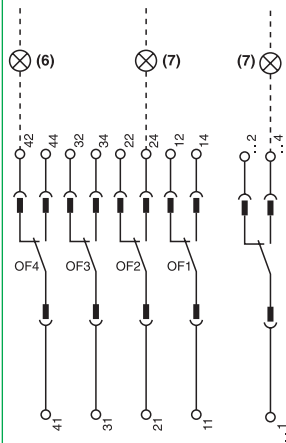

OF4	OF3	OF2	OF1	OF14	OF13	OF12	OF11
○ 44 ○	○ 34 ○	○ 24 ○	○ 14 ○	○ 144 ○	○ 134 ○	○ 124 ○	○ 114 ○
○ 42 ○	○ 32 ○	○ 22 ○	○ 12 ○	○ 142 ○	○ 132 ○	○ 122 ○	○ 112 ○
○ 41 ○	○ 31 ○	○ 21 ○	○ 11 ○	○ 141 ○	○ 131 ○	○ 121 ○	○ 111 ○

**Chassis switches / 位置触点 / Contacts châssis / Contactos del chasis / Interruptores de chasis**

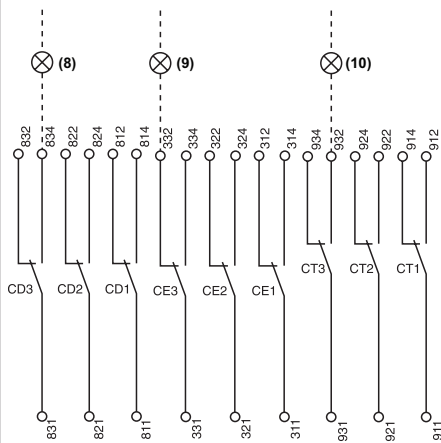

CD3	CD2	CD1	CE3	CE2	CE1	CT3	CT2	CT1
○ 834 ○	○ 824 ○	○ 814 ○	○ 334 ○	○ 324 ○	○ 314 ○	○ 934 ○	○ 924 ○	○ 914 ○
○ 832 ○	○ 822 ○	○ 812 ○	○ 332 ○	○ 322 ○	○ 312 ○	○ 932 ○	○ 922 ○	○ 912 ○
○ 831 ○	○ 821 ○	○ 811 ○	○ 331 ○	○ 321 ○	○ 311 ○	○ 931 ○	○ 921 ○	○ 911 ○

- (6) Open / 分闸 / Ouvert / Abierto / Aberto
- (7) Closed / 合闸 / Fermé / Cerrado / Fechado
- (8) Disconnected / 退出 / Débroché / Desenchufado / Desligado ou ligado aberto
- (9) Connected / 连接 / Embroché / Enchufado / Ligado
- (10) Test position / 测试位置 / Position test / Posición de teste

# Radio Frequency Compliance Statement for TS Trip System / TS 脱扣单元的射频合规声明 / Déclaration de conformité des fréquences radio pour le système de déclenchement TS / Declaración de cumplimiento de la radiofrecuencia para el sistema de disparo TS / Declaração de conformidade de radiofrequência para sistema de disparo TS

Europe / Europe / Europa / Europa	
<p><b>(EN) EU Declaration of Conformity</b>            Hereby, Schneider Electric Industries SAS, declares that the TS trip system installed inside EasyPact MVS circuit breaker is in compliance with the essential requirements and other relevant provisions of RED Directive 2014/53/EU.            Frequency bands in which the radio equipment operates:  <ul style="list-style-type: none"> <li>● NFC operating frequency: 13.56 MHz.</li> </ul>           Maximum radio-frequency power radiated in the frequency bands in which the radio equipment operates is less than 10 mW (EIRP).            The EU declarations of conformity for EasyPact MVS circuit breakers with TS trip system can be downloaded on <a href="http://www.se.com/docs">www.se.com/docs</a>:  <ul style="list-style-type: none"> <li>● PB20110402C: EU declaration of conformity for EasyPact MVS1(C) circuit breakers with TS trip system.</li> <li>● PB16060901E: EU declaration of conformity for EasyPact MVS2(N/H) circuit breakers with TS trip system.</li> <li>● PB23021301A: EU declaration of conformity for EasyPact MVS2(T) circuit breakers with TS trip system.</li> </ul> </p>	<p><b>(FR) Déclaration de conformité UE</b>            Schneider Electric Industries SAS déclare ici que le système de déclenchement TS installé à l'intérieur du disjoncteur EasyPact MVS est conforme aux exigences essentielles et autres dispositions pertinentes de la directive RED 2014/53/UE.            Bandes de fréquences de fonctionnement de l'équipement radio :  <ul style="list-style-type: none"> <li>● Fréquence de fonctionnement NFC: 13.56 MHz.</li> </ul>           La puissance de radiofréquence maximale émise dans les bandes de fréquence de fonctionnement de l'équipement radio est inférieure à 10 mW (EIRP).            Les déclarations de conformité UE des disjoncteurs EasyPact MVS avec système de déclenchement TS peuvent être téléchargées sur <a href="http://www.se.com/docs">www.se.com/docs</a>:  <ul style="list-style-type: none"> <li>● PB20110402C: Déclaration de conformité UE pour les disjoncteurs EasyPact MVS1(C) avec système de déclenchement TS.</li> <li>● PB16060901E: Déclaration de conformité UE pour les disjoncteurs EasyPact MVS2(N/H) avec système de déclenchement TS.</li> <li>● PB23021301A: Déclaration de conformité UE pour les disjoncteurs EasyPact MVS2(T) avec système de déclenchement TS.</li> </ul> </p>
<p><b>(ES) Declaración de conformidad de la UE</b>  <ul style="list-style-type: none"> <li>● Por medio del presente, Schneider Electric Industries SAS, declara que el sistema de disparo TS que está instalado en el interior del interruptor automático EasyPact MVS cumple con los requisitos esenciales y otras disposiciones pertinentes de la Directiva RED 2014/53/UE.</li> </ul>           Bandas de frecuencias en las que funciona el equipo de radio:  <ul style="list-style-type: none"> <li>● Frecuencia operativa NFC: 13.56 MHz.</li> </ul>           La potencia máxima de radiofrecuencia radiada en las bandas de frecuencia en las que funciona el equipo de radio es inferior a 10 mW (EIRP).            Las declaraciones de conformidad de la UE para los interruptores automáticos EasyPact MVS con sistema de disparo TS se pueden descargar en <a href="http://www.se.com/docs">www.se.com/docs</a>:  <ul style="list-style-type: none"> <li>● PB20110402C: Declaración de la UE de conformidad para interruptores automáticos EasyPact MVS1(C) con sistema de disparo TS.</li> <li>● PB16060901E: Declaración de la UE de conformidad para interruptores automáticos EasyPact MVS2(N/H) con sistema de disparo TS.</li> <li>● PB23021301A: Declaración de la UE de conformidad para interruptores automáticos EasyPact MVS2(T) con sistema de disparo TS.</li> </ul> </p>	<p><b>(PT) Declaração de conformidade UE</b>  <ul style="list-style-type: none"> <li>● A Schneider Electric Industries SAS declara que o sistema de disparo TS instalado no interior do disjuntor MVS do EasyPact está em conformidade com os requisitos essenciais e outras disposições relevantes da Diretiva RED 2014/53/UE.</li> </ul>           Faixa de frequências em que o equipamento de rádio funciona:  <ul style="list-style-type: none"> <li>● Frequência de funcionamento NFC: 13.56 MHz.</li> </ul>           A potência máxima de radiofrequência irradiada nas bandas de frequência em que o equipamento de rádio funciona é inferior a 10 mW (EIRP).            As declarações de conformidade UE para disjuntores MVS de EasyPact com sistema de disparo TS podem ser transferidas em <a href="http://www.se.com/docs">www.se.com/docs</a>:  <ul style="list-style-type: none"> <li>● PB20110402C: Declaração de conformidade UE para disjuntores MVS1(C) com sistema de disparo TS.</li> <li>● PB16060901E: Declaração de conformidade UE para disjuntores MVS2(N/H) com sistema de disparo TS.</li> <li>● PB23021301A: Declaração de conformidade UE para disjuntores MVS2(T) com sistema de disparo TS.</li> </ul> </p>

## TS Trip System Setting / TS 脱扣单元设置 / Réglage du système de déclenchement TS / Configuración del sistema de disparo TS / Definição do sistema de disparo TS

### ▲ WARNING / 警告 / AVERTISSEMENT / ADVERTENCIA / ATENÇÃO

#### HAZARD OF FIRE

- It is recommended not to set the long-time overcurrent protection pickup (Ir) to off.
  - When Ir is set to off, the long-time protection does not protect the system against overload. The instantaneous and/or short-time protections must be set accordingly.
- Failure to follow these instructions can result in death, serious injury, or equipment damage.**

#### 火灾危险

- 建议不要将长延时过载保护电流 (Ir) 设置为关闭。
  - 当 Ir 设置为关闭时, 长延时保护无法防止系统过载。必须相应地设置瞬时和/或短延时保护。
- 未按说明操作可能导致人身伤亡或设备损坏等严重后果。**

#### RISQUE D'INCENDIE

- Il est recommandé de ne pas régler le seuil de déclenchement de la protection long retard contre les surintensités (Ir) sur Off.
  - Lorsque Ir est réglé sur Off, la protection long retard ne protège pas le système contre les surcharges. Les protections instantanées et/ou court retard doivent être réglées en conséquence.
- Le fait de ne pas suivre ces instructions peut entraîner des blessures graves, voire mortelles, ou endommager l'équipement.**

#### RIESGO DE INCENDIO

- Se recomienda no desactivar la activación de protección contra sobrecorriente de larga duración (Ir).
  - Cuando Ir está apagado, la protección de larga duración no protege al sistema contra sobrecargas. Las protecciones instantáneas o de corta duración deben ajustarse según corresponda.
- El incumplimiento de estas instrucciones podría tener como resultado la muerte, lesiones graves o provocar daños en el equipo.**

#### PERIGO DE INCÊNDIO

- Não é recomendável definir a recolha de proteção contra sobreintensidade de longa duração (Ir) para desligada.
  - Quando Ir está definido como desligado, a proteção de longa duração não protege o sistema contra sobrecargas. As proteções imediatas e/ou de curta duração devem ser definidas em conformidade.
- O não cumprimento destas instruções pode resultar em morte, lesões graves ou danos no equipamento.**

# TS Trip System Setting / TS 脱扣单元设置 / Réglage du système de déclenchement TS / Configuración del sistema de disparo TS / Definição do sistema de disparo TS

## NOTICE / 注意 / AVIS / AVISO / AVISO

<p><b>HAZARD OF UNINTENDED OPERATION</b></p> <ul style="list-style-type: none"> <li>● The device must only be configured and set by qualified personnel, using the results of the installation protection system study.</li> <li>● During commissioning of the installation and following any modification, check that the TS trip system configuration and protection function settings are consistent with the results of this study.</li> <li>● TS trip system protection functions are set by default to the minimum value, except the long-time protection function, set by default to the maximum value.</li> </ul> <p><b>Failure to follow these instructions can result in equipment damage.</b></p>	<p><b>意外操作风险</b></p> <ul style="list-style-type: none"> <li>● 设备只能由有资格的人员，利用安装保护系统研究的结果进行配置和设定。</li> <li>● 在安装调试期间及进行任何更改之后，检查 TS 脱扣单元配置和保护功能设置是否与此研究的结果一致。</li> <li>● TS 脱扣单元保护功能默认设置为最小值，但长期保护功能除外，后者默认设置为最大值。</li> </ul> <p><b>不遵循上述说明可能导致设备损坏。</b></p>	<p><b>RISQUE DE FONCTIONNEMENT INATTENDU</b></p> <ul style="list-style-type: none"> <li>● L'appareil doit être configuré et réglé par du personnel qualifié, en utilisant les résultats de l'étude du système de protection de l'installation.</li> <li>● Pendant la mise en service de l'installation et après toute modification, vérifiez que la configuration du système de déclenchement TS et les paramètres des fonctions de protection sont en accord avec les résultats de cette étude.</li> <li>● Les fonctions de protection du système de déclenchement TS sont réglées par défaut sur la valeur minimale, à l'exception de la fonction de protection long retard qui est réglée par défaut sur la valeur maximale.</li> </ul> <p><b>Le fait de ne pas suivre ces instructions peut endommager l'équipement.</b></p>	<p><b>PELIGRO DE OPERACIÓN NO INTENCIONAL</b></p> <ul style="list-style-type: none"> <li>● El dispositivo solo debe ser configurado e instalado por personal calificado, usando los resultados del estudio del sistema de protección de la instalación.</li> <li>● Durante la puesta en marcha de la instalación y después de cualquier modificación, verifique que la configuración del sistema de disparo TS y los ajustes de la función de protección sean congruentes con los resultados de este estudio.</li> <li>● Las funciones del sistema de disparo TS se establecen de forma predeterminada al valor mínimo, a excepción de la función de protección de larga duración, que se establece de forma predeterminada al valor máximo.</li> </ul> <p><b>El incumplimiento de estas instrucciones podría provocar daños en el equipo.</b></p>	<p><b>PERIGO DE FUNCIONAMENTO INDESEJADO</b></p> <ul style="list-style-type: none"> <li>● O dispositivo só pode ser configurado e definido por pessoal qualificado, utilizando os resultados do estudo do sistema de proteção da instalação.</li> <li>● Durante a colocação em funcionamento da instalação e após qualquer modificação, verifique se as definições da função de proteção e configuração do sistema de disparo TS estão consistentes com os resultados deste estudo.</li> <li>● As funções de proteção do sistema de disparo TS são definidas por padrão para o valor mínimo, exceto a função de proteção de longa duração, definida por padrão para o valor máximo.</li> </ul> <p><b>O não cumprimento destas instruções pode resultar em danos no equipamento.</b></p>
--	--	--	--	---

---

**Schneider Electric Industries SAS**  
35 rue Joseph Monier  
92500 Rueil-Malmaison  
France  
[www.se.com](http://www.se.com)

