

Altivar 212

Variable speed drives
for synchronous and asynchronous motors

Programming Manual

06/2025



The information provided in this documentation contains general descriptions and/or technical characteristics of the performance of the products contained herein. This documentation is not intended as a substitute for and is not to be used for determining suitability or reliability of these products for specific user applications. It is the duty of any such user or integrator to perform the appropriate and complete risk analysis, evaluation and testing of the products with respect to the relevant specific application or use thereof. Neither Schneider Electric nor any of its affiliates or subsidiaries shall be responsible or liable for misuse of the information contained herein. If you have any suggestions for improvements or amendments or have found errors in this publication, please notify us.

No part of this document may be reproduced in any form or by any means, electronic or mechanical, including photocopying, without express written permission of Schneider Electric.

All pertinent state, regional, and local safety regulations must be observed when installing and using this product. For reasons of safety and to help ensure compliance with documented system data, only the manufacturer should perform repairs to components.

When devices are used for applications with technical safety requirements, the relevant instructions must be followed.

Failure to use Schneider Electric software or approved software with our hardware products may result in injury, harm, or improper operating results.

Failure to observe this information can result in injury or equipment damage.

© 2025 Schneider Electric. All rights reserved.

Table of Contents

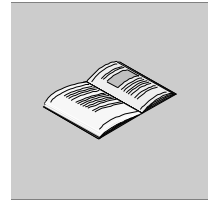

	Safety Information	7
	About the Book	8
	General Overview	11
Chapter 1	Setup	13
	Steps for setting-up the drive	14
Chapter 2	Overview	15
	Factory configuration	16
	Preliminary recommendations	17
	Embedded display terminal	18
	Monitoring Mode	20
	Run Mode	23
	Programming Mode	23
	Menu Navigation	24
	Submenus	34
	Graphic display option	35
	Finding a parameter in this document	37
	Detected fault screens	37
	Pre-alarms screens	38
	Modbus communication status	38
	SoMove software	39
	Structure of the parameter tables	40
	Parameters that cannot be changed while the drive is running	41
	Common control schemes	42
	Drive Operation	49
	Programming	57
Chapter 3	Quick Menu	59
	Quick menu	60
Chapter 4	Programming Parameters	65
	Parameter Reset	66
	Macro Programming (AU4)	67
	Parameter Lock	68
	Display of Submenu AUF (F738)	68
Chapter 5	Motor Control Parameters	69
	Motor Control Mode	70
	Other Motor Control Mode Parameters	72
	Motor Tuning	74
	Auto-tuning	75
	Expert parameters	77
	Supply Voltage Correction and Motor Voltage Limitation	78

	Motor 2 Control Parameters	79
	Permanent Magnet Motor Control Law ([PM Control] (Pn))	81
Chapter 6	Drive Control Parameters	87
Chapter 7	Application Parameters	91
	Application parameters	92
	Skip Frequencies	97
	DC Injection Braking Parameters	98
Chapter 8	I/O Control Parameters	99
	Logic Inputs Functions	100
	Logic Input Function Compatibility	107
	Relay Output Functions	108
	Analog Input Functions	114
	Analog Output Functions	115
	Analog Input Adjustments	116
	Active Logic Function	122
	Preset Speeds	123
	+/- Speed Control Parameters	124
	Damper control	127
Chapter 9	Display Parameters	129
	Display parameters	130
Chapter 10	Detected Fault Management Parameters	133
	Time delay	136
	Catch On The Fly (F301)	137
	Overtorque Detection	143
	Nuisance Overvoltage And Input Phase Detected Fault Avoidance	144
	Motor Overload Characteristics	145
Chapter 11	Serial Communication Parameters	147
	Network communication between the ATV212 drive and a master controller	148
	Data structure parameters	150
Chapter 12	Start/Stop Control By Speed Reference Level.	153
	Overview	154
Chapter 13	Droop Control	155
	Droop control principle	156
Chapter 14	Functions for Scroll	157
	Driving Scroll (F324)	160
	Pre-start Scroll (F325)	170
	Std Oiling Cycle (F330)	172
	Low Speed Oiling (F334)	173
	Scroll Protection (F338)	174
	Discharge gas (F349)	175
	Crankcase heating (F355)	176
	Diagnostics and troubleshooting	177
Chapter 15	Diagnostics and troubleshooting	179
	Detected fault conditions	180
	Alarm Conditions	184
	Pre-alarm Conditions	186
	Clearing the detected fault	187

Annex	189
Chapter 16 Migration	191
Migration ATV21 - ATV212.....	192
Chapter 17 Parameters Reset Tables	193
Parameter values that do not vary by reset type	194
Parameter values that vary according to reset type	198
Parameter values that vary According to drive rating, but not reset type	199
Parameter values that vary According to drive rating and reset type	200
Parameter values that do not change if reset.....	201
Chapter 18 User Settings Tables	203

Safety Information

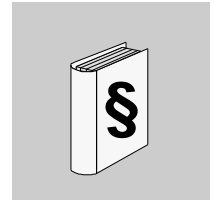

Important Information

NOTICE

Please read these instructions carefully and examine the equipment in order to familiarize yourself with the device before installing, operating or carrying out any maintenance work on it.

The following special messages that you will come across in this document or on the device are designed to warn you about potential risks or draw your attention to information that will clarify or simplify a procedure.



The addition of this symbol to a Danger or Warning safety label indicates that an electrical hazard exists, which will result in personal injury if the instructions are not followed.



This is the safety alert symbol. It is used to alert you to potential personal injury hazards. Obey all safety messages that follow this symbol to avoid possible injury or death.

⚠ DANGER

DANGER indicates an imminently hazardous situation, which, if not avoided, **will result** in death or serious injury.

⚠ WARNING

WARNING indicates a potentially hazardous situation, which, if not avoided, **can result** in death, serious injury, or equipment damage.

⚠ CAUTION

CAUTION indicates a potentially hazardous situation, which, if not avoided, **can result** in injury or equipment damage.

NOTICE

NOTICE, used without the safety alert symbol, indicates a potentially hazardous situation which, if not avoided, **can result** in equipment damage.

PLEASE NOTE

The word "drive" as used in this manual refers to the controller portion of the adjustable speed drive as defined by NEC.

Electrical equipment should be installed, operated, serviced, and maintained only by qualified personnel. No responsibility is assumed by Schneider Electric for any consequences arising out of the use of this product.

© 2025 Schneider Electric. All Rights Reserved.

About the Book

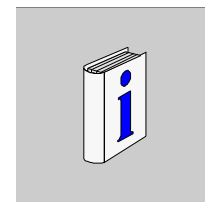

At a Glance

Document scope

The purpose of this document is to:

- help you to set-up the drive,
- show you how to program the drive,
- show you the different menus, modes and parameters,
- help you in maintenance and diagnostics.

Validity note

This documentation is valid for the Altivar 212 drive.

Related documents

Title of Documentation	Reference Number
ATV212 Quick Start	S1A53825
ATV212 Installation manual	S1A53832
ATV212 Modbus manual	S1A53844
ATV212 BACnet manual	S1A53845
ATV212 Metasys N2 manual	S1A53846
ATV212 Apogée FLN P1 manual	S1A53847
ATV212 LonWorks manual	S1A53848
Multi-Loader manual	BBV48778
SoMove Mobile manual	S1A51444
ATV212 other option manuals: see www.se.com	

You can download the latest versions of these technical publications and other technical information from our website at www.se.com.

Standards and Terminology

The technical terms, terminology, and the corresponding descriptions in this manual normally use the terms or definitions in the relevant standards.

In the area of drive systems this includes, but is not limited to, terms such as **error**, **error message**, **failure**, **fault**, **fault reset**, **protection**, **safe state**, **safety function**, **warning**, **warning message**, and so on.

Among others, these standards include:

- IEC 61800 series: Adjustable speed electrical power drive systems
- IEC 61508 Ed.2 series: Functional safety of electrical/electronic/programmable electronic safety-related
- EN 954-1 Safety of machinery - Safety related parts of control systems
- EN ISO 13849-1 & 2 Safety of machinery - Safety related parts of control systems.
- IEC 61158 series: Industrial communication networks - Fieldbus specifications
- IEC 61784 series: Industrial communication networks - Profiles
- IEC 60204-1: Safety of machinery - Electrical equipment of machines – Part 1: General requirements

Product related information

⚠️ ⚠️ DANGER

HAZARD OF ELECTRIC SHOCK, EXPLOSION OR ARC FLASH

- Only appropriately trained persons who are familiar with and understand the contents of this manual and all other pertinent product documentation and who have received safety training to recognize and avoid hazards involved are authorized to work on and with this drive system. Installation, adjustment, repair and maintenance must be performed by qualified personnel.
- The system integrator is responsible for compliance with all local and national electrical code requirements as well as all other applicable regulations with respect to grounding of all equipment.
- Many components of the product, including the printed circuit boards, operate with mains voltage. Do not touch. Use only electrically insulated tools.
- Do not touch unshielded components or terminals with voltage present.
- Motors can generate voltage when the shaft is rotated. Prior to performing any type of work on the drive system, block the motor shaft to prevent rotation.
- AC voltage can couple voltage to unused conductors in the motor cable. Insulate both ends of unused conductors of the motor cable.
- Do not short across the DC bus terminals or the DC bus capacitors or the braking resistor terminals.
- Before performing work on the drive system:
 - Disconnect all power, including external control power that may be present.
 - Place a "Do Not Turn On" label on all power switches.
 - Lock all power switches in the open position.
 - Wait 15 minutes to allow the DC bus capacitors to discharge. The DC bus LED is not an indicator of the absence of DC bus voltage that can exceed 800 Vdc.
 - Measure the voltage on the DC bus between the DC bus terminals (PA/+ and PC/-) using a properly rated voltmeter to verify that the voltage is < 42 Vdc.
 - If the DC bus capacitors do not discharge properly, contact your local Schneider Electric representative.
- Install and close all covers before applying voltage.

Failure to follow these instructions will result in death or serious injury.

⚠️ DANGER

UNINTENDED EQUIPMENT OPERATION

- Prevent accidental grounding of logic inputs configured for sink logic. Accidental grounding can result in unintended activation of drive functions.
- Protect the signal conductors against damage that could result in unintentional conductor grounding.

Failure to follow these instructions will result in death or serious injury.

⚠️ WARNING

LOSS OF CONTROL

- The designer of any control scheme must consider the potential failure modes of control paths and, for critical control functions, provide a means to achieve a safe state during and after a path failure. Examples of critical control functions are emergency stop, overtravel stop, power outage, and restart.
- Separate or redundant control paths must be provided for critical control functions.
- System control paths may include communication links. Consideration must be given to the implications of unanticipated transmission delays or failures of the link.
- Observe all accident prevention regulations and local safety guidelines (1).
- Each implementation of the product must be individually and thoroughly tested for proper operation before being placed into service.

Failure to follow these instructions can result in death, serious injury, or equipment damage.

(1) For USA: Additional information, refer to NEMA ICS 1.1 (latest edition), "Safety Guidelines for the Application, Installation, and Maintenance of Solid State Control" and to NEMA ICS 7.1 (latest edition), "Safety Standards for Construction and Guide for Selection, Installation and Operation of Adjustable Speed Drive Systems."

General Overview

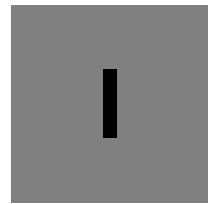

What's in this Part?

This part contains the following chapters:

Chapter	Chapter Name	Page
1	Setup	13
2	Overview	15

Setup



1

What's in this Chapter?

This chapter contains the following topics:

Topic	Page
Steps for setting-up the drive	14

Steps for setting-up the drive

INSTALLATION

1. Please, refer to the installation manual..

PROGRAMMING



Tips:

- Before beginning programming, complete the customer setting tables, page [203](#).
- Perform an auto-tuning operation to optimize performance, page [75](#).
- If you get lost, return to the factory settings, page [66](#).

2. Apply input power to the drive, but do not give a run command.

3. Configure

- the nominal frequency of the motor [Parameter reset] (*E 4 P*) = [50 Hz reset] (*I*) if this is not 50Hz,
- the motor parameters, page [70](#), only if the factory configuration of the drive is not suitable,
- the application functions in the Drive Control Parameters section, page [87](#) and the I/O Control Parameters section, page [99](#), only if the factory configuration of the drive is not suitable.

4. Adjust the application parameters

- [Acceleration time 1] (*A C C*), page [93](#) and [Deceleration time 1] (*d E C*), page [93](#).
- [Low limit frequency] (*L L*), page [92](#) and [Upper limit freq] (*u L*), page [92](#).
- [Motor thermal prot.] (*E H r*), page [74](#).

5. Start the drive

Overview

2

What's in this Chapter?

This chapter contains the following topics:

Topic	Page
Factory configuration	16
Preliminary recommendations	17
Embedded display terminal	18
Monitoring Mode	20
Run Mode	23
Programming Mode	23
Menu Navigation	24
Submenus	34
Graphic display option	35
Finding a parameter in this document	37
Detected fault screens	37
Pre-alarms screens	38
Modbus communication status	38
SoMove software	39
Structure of the parameter tables	40
Parameters that cannot be changed while the drive is running	41
Common control schemes	42
Drive Operation	49

Factory configuration

Drive factory settings

The Altivar 212 is factory-set for the most common operating conditions:

- [Mot cont. mode sel.] ($P L$): [Variable torque] ($P L = 1$). See page [71](#).
- [Upper limit freq] ($U L$) = 50.0 Hz. See page [92](#).
- [Low limit frequency] ($L L$) = 0.0 Hz. See page [92](#).
- [Switch. freq. level] ($F 3 0 0$): depending on drive rating (see page [95](#))
- [Auto ramp] ($A U 1$) = [Enable] ($A U 1 = 1$). See page [95](#).

Parameter which depends on Macro Programming [Auto set function] ($A U 4$) = 0 (see page [67](#)):

- Command reference: logic inputs ([Command mode sel] ($C P 0 d$) = 0). See page [87](#).
- Speed reference: analog input VIA = 0–10 V or 0–20 mA ([Frequency mode sel] ($F P 0 d$) = 1, ($F 2 0 1$) = 0). See [Frequency mode sel] ($F P 0 d$) page [87](#) and Analog Input Speed Reference page [116](#).
- F: run forward ($F 1 1 1$ = 2). See [LI F selection] page [100](#).
- R: preset speed 1 ($F 1 1 2$ = 6). See [LI R selection] page [100](#).
- RES: clear detected fault ($F 1 1 3$ = 10). See [LI RES selection] page [100](#).
- Drive ready for operation ($F 1 1 0$ = 1). See [Logic Funct 2 active] page [122](#).

If the above values are compatible with the application, the drive can be used without changing the settings.

Preliminary recommendations

NOTICE

INCOMPATIBLE LINE VOLTAGE

Before turning on and configuring the drive, ensure that the line voltage is compatible with the supply voltage range shown on the drive nameplate. The drive may be damaged if the line voltage is not compatible.

Failure to follow these instructions can result in equipment damage.

Power switching via line contactor

NOTICE

RISK OF DAMAGE TO THE DRIVE

- Avoid operating the contactor frequently.
- Power cycling must be MORE than 60 seconds.

Failure to follow these instructions can result in equipment damage.

User adjustment and extension of functions

- The display unit and buttons can be used to modify the settings and to extend the functions described in the following pages.
- **Return to factory settings** is made easy by the [Parameter reset] (**ⓧ** **Ⓨ** **Ⓟ**) (see page 66).

⚠ DANGER

UNINTENDED EQUIPMENT OPERATION

Check that changes made to the settings during operation do not present any danger. We recommend stopping the drive before making any changes.

Failure to follow these instructions will result in death or serious injury.

Test on a low power motor or without a motor

- In factory settings mode, [Output phase loss] (**F 6 0 5**) (page 140) is active **F 6 0 5 = 3**. To check the drive in a test or maintenance environment without having to switch to a motor with the same rating as the drive (particularly useful in the case of high power drives), set **F 6 0 5** to **0**.
- Set [Mot cont. mode sel.] (**P 1**) = [Constant V/Hz] (**0**) (see page 71).

NOTICE

UNINTENDED EQUIPMENT OPERATION

Motor thermal protection will not be provided by the drive if the motor 's nominal current is 20% lower than that of the drive. Find an alternative source of thermal protection.

Failure to follow these instructions can result in equipment damage.

Using motors in parallel

- Set [Mot cont. mode sel.] (**P 1**) = [Constant V/Hz] (**0**) (see page 71).

NOTICE

RISK OF DAMAGE TO THE MOTOR

Motor thermal protection is no longer provided by the drive. Provide an alternative means of thermal protection.

Failure to follow these instructions can result in equipment damage.

Using in single phase supply

- Set [Input phase loss] (**F 6 0 B**) to Disabled **0** (see page 138).

NOTICE

RISK OF DAMAGE TO THE DRIVE

Using ATV212 in single phase supply is only allowed in training mode with motor and without load.

Failure to follow these instructions can result in equipment damage.

Embedded display terminal

This section describes the features of the integrated display terminal.

Embedded display terminal features

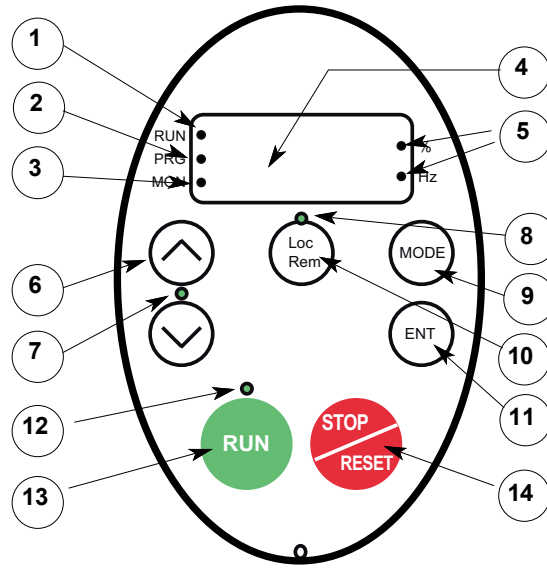

LED/Key	Characteristics
1 Display RUN LED	Illuminates when a run command is applied to the drive. Flashes when there is a speed reference present with a Run command.
2 Display PRG LED	Illuminates when Programming mode is active. Flashes in <i>R u F</i> , <i>G r u</i> modes
3 Display MON LED	Illuminates when Monitoring mode is active. Flashes in detected fault history display mode
4 Display unit	4 digits, 7 segments
5 Display unit LED	The % LED illuminates when a displayed numeric value is a percentage. The Hz LED illuminates when a displayed numeric value is in hertz.
6 UP/DOWN keys	Depending on the mode, you can use the arrows to: Navigate between the menus Change a value Change the speed reference when the UP/DOWN LED (7) is illuminated
7 UP/DOWN LED	Illuminates when the navigation arrows are controlling the speed reference
8 Loc/Rem LED	Illuminates when Local mode is selected
9 MODE	Press to select the embedded display terminal mode. Run mode (default on power-up) Programming mode Monitoring mode Can also be used to go back to the previous menu.
10 Loc/Rem	Switches between Local and Remote modes
11 ENT	Press to display a parameter's value or to save a changed value.
12 RUN LED	Illuminates when the Run key is enabled
13 RUN	Pressing this key when the RUN LED is illuminated starts the drive.
14 STOP	Stop/reset key. In Local mode, pressing the STOP key causes the drive to stop based on the setting of parameter [Loc. mot stop mode] (<i>F 7 2 1</i>). In Remote mode, pressing the STOP key causes the drive to stop based on the setting of parameter [Ext. fault stop Mode] (<i>F 6 0 3</i>). The display will indicate a flashing "E". If [HMI reset button] (<i>F 7 3 5</i>) is set to 0, pressing the stop key twice will reset the drive, if the detected fault condition has been cleared.

An optional graphic display option (VW3A1101) is also available.

Embedded display terminal modes

The Altivar 212 embedded display terminal has three modes of operation: Monitoring, Run and Programming. The drive powers up in the Run mode. To select a different mode, use the MODE key as illustrated below.

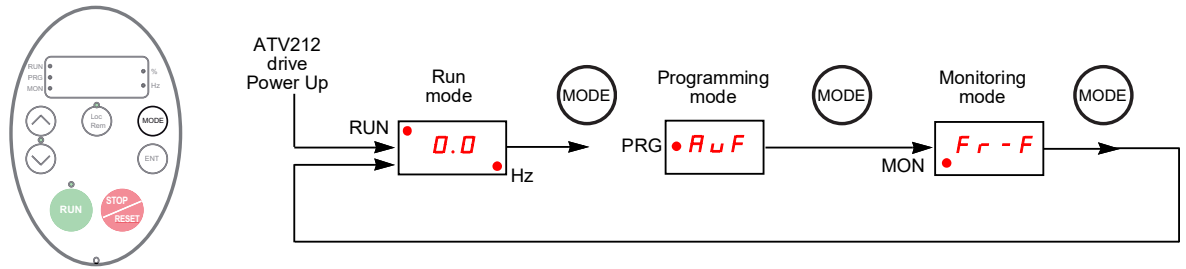

The red LED in left side of the display indicates the current mode selected, RUN for Run mode, PRG for Programming mode and MON for Monitoring mode.

Monitoring Mode

The Monitoring mode displays drive operational data in real time. To access the Monitoring mode, press the MODE key until the MON LED is illuminated. Then use the UP and DOWN keys to view up to 30 different types of data.

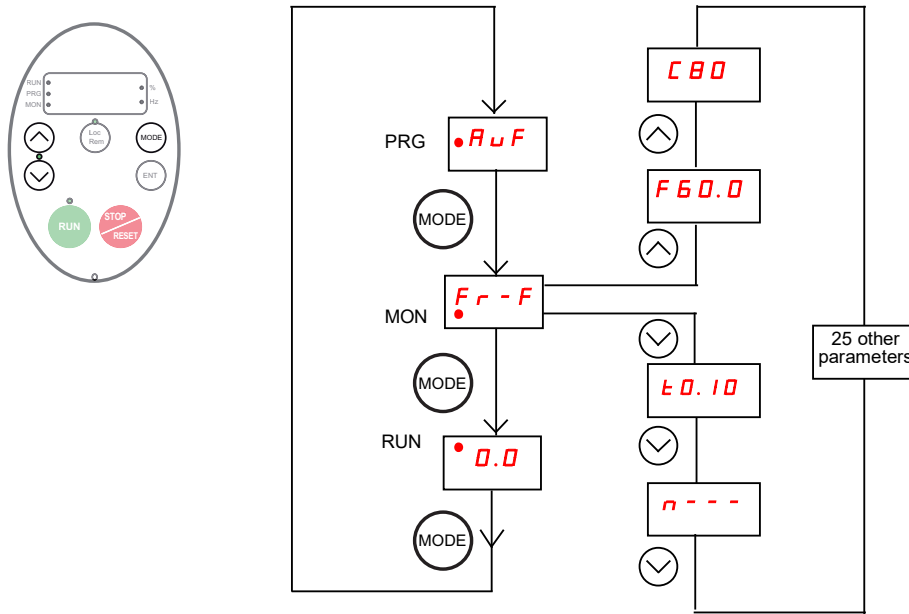

Monitoring Mode Displays

Display example	Display on graphic terminal	Description
<i>Fr-F</i>	[Direction]	<i>Fr-F</i> = [Forward] <i>Fr-r</i> = [Reverse]
<i>F60.0</i>	[Speed reference]	Command frequency to drive, displayed either as Hz or in custom unit set by parameter [Customized freq val] (<i>F702</i>)
<i>C80</i>	[Motor current]	The average of the 3 phases of motor current displayed either as amperes or as a percentage of the drive's nameplate-rated output current. Select % or A with parameter [Unit value selection] (<i>F701</i>).
<i>Y100</i>	[Line voltage]	The average of the 3 phases of line to line input voltages displayed either in volts or as a percentage of the drive's rated input voltage (200 V for 208/240 V models - 400 V for 480 V models). Select % or volts with parameter [Unit value selection] (<i>F701</i>).
<i>P100</i>	[Motor voltage]	The average of the 3 phases of line to line output voltages displayed either in volts or as a percentage of the drive's rated output voltage (200 V for 208/240 V models - 400 V for 480 V models). Select % or volts with parameter [Unit value selection] (<i>F701</i>).
<i>q60</i>	[Motor torque %]	Estimated motor torque as a percentage of the motor's rated torque
<i>c90</i>	[Torque current]	The average of the 3 phases of torque-producing motor current displayed either as amperes or as a percentage of the motor's rated torque-producing current. Select % or A with parameter [Unit value selection] (<i>F701</i>).
<i>L70</i>	[Drive load %]	The motor current as a percentage of the drive's rated output current, which may be reduced from the drive's nameplate current rating by adjustments in switching frequency.
<i>h80</i>	[Input power KW]	drive input power displayed in accordance with parameter [Power cons. unit] (<i>F749</i>).
<i>H75</i>	[Output power KW]	drive output power displayed in accordance with parameter [Power cons. unit] (<i>F749</i>).
<i>o60.0</i>	[Motor frequency]	Motor operating frequency, displayed either as Hz or in custom unit set by parameter [Customized freq val] (<i>F702</i>)
<i>..11</i>	[Logic input map]	<p>ON: # OFF: .</p> <p>The bar representing VIA is displayed only if <i>F109</i> = 1 or 2</p>

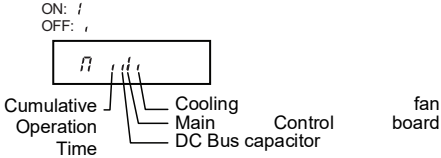
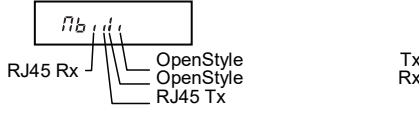
Display example	Display on graphic terminal	Description
D. I	[Relay map]	ON: / OFF: , 
u 10 I	[CPU CTRL ver.]	CTRL version 101
uc 0 I	[CPU MMI ver.]	MMI version 1.0
uE 0 I	[Memory ver.]	Version of memory
d 50.0	[PID feedback]	Level of PID feedback, displayed either as Hz or in custom unit set by parameter [Customized freq val] (F 702)
b 70.0	[PID computed ref.] speed reference	Speed reference command to drive as computed by the PID function, displayed either as Hz or in custom unit set by parameter [Customized freq val] (F 702)
h 85	[Total input power]	Accumulated input power consumed by the drive displayed in kWh
H 75	[Total motor power]	Accumulated output power supplied by the drive displayed in kWh
A 16.5	[Drive out. rat. cur. A]	Drive nameplate rated output current in amperes
1500	[Motor speed rpm]	Motor speed in rpm
n 50	[Comm. counter 2]	Displays the counter numbers of communication through the network
n 50	[Comm. counter 1]	Displays the counter numbers of communication only at normal state in every communication through the network
nErr	[Past fault] Examples: - 1 blink Err5 - 2 blink Err5 - 3 blink CFI2 - 4 blink nErr	The most recent detected fault stored in the detected fault history. If the drive is in a detected fault state, this is not the active detected fault. A detected fault is stored in the detected fault history after it is cleared by clear detected fault action. Press ENT to review drive state at time of detected fault. See "Detected fault Display and History" on page 21 and "Diagnostics and troubleshooting" on page 179 for more detail. There are 4 detected faults recorded. The detected fault 4 is cleared when a new detected fault appears.
n... I	[Drive service alarm]	ON: / OFF: , 
n b...	[Mdb com stat]	ON: / OFF: , 
t 0.10	[Drive run time 100h]	Cumulative drive run time. 0.01 = 1 hour. 1.00 = 100 hours



Detected fault display and history

When the drive detected faults, the graphic terminal displays a code. To review data about drive operation at the time of the detected fault, press the MODE key to enter the Monitoring mode. Then use the Up/Down keys to scroll through the data listed in table page 20.

Up to five detected faults can be displayed on the graphic terminal in Monitoring mode: the present detected fault (if the drive is in a detected fault state) and the previous four detected fault codes. To review drive operation data recorded at the time of detected fault for a previous detected fault, press ENT when the code for the detected fault is displayed. See table below for the available information.

When a detected fault is cleared or power is cycled to the drive, the present detected fault becomes Past detected fault 1.

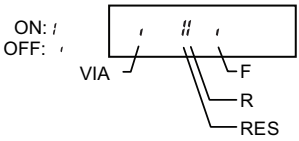
Detected fault History

Display	Display on graphic terminal	Description
n 2	[Comm. counter 1]	Number of times in succession that this particular detected fault has occurred
o 60.0	[Motor frequency]	Motor operating frequency, displayed either as Hz or in custom unit set by parameter [Customized freq val] (F 702)
F r - F	[Direction]	F r - F = [Forward] F r - r = [Reverse]
F 60.0	[Speed reference]	Command frequency to drive, displayed either as Hz or in custom unit set by parameter [Customized freq val] (F 702)
C 80	[Motor current]	The average of the 3 phases of motor current displayed either as A or as a percentage of the drive's nameplate-rated output current. Select % or A with parameter [Unit value selection] (F 701).
Y 100	[Line voltage]	The average of the 3 phases of line to line input voltages displayed either in volts or as a percentage of the drive's rated input voltage (200 V for 208/240 V models - 400 V for 480V models). Select % or volts with parameter [Unit value selection] (F 701).
P 100	[Motor voltage]	The average of the 3 phases of line to line output voltages displayed either in volts or as a percentage of the drive's rated output voltage (200 V for 208/240 V models - 400 V for 480 V models). Select % or volts with parameter [Unit value selection] (F 701).
.. 11	[LOGIC INPUT MAP] Logic input map	 <p>ON: / OFF: ,</p> <p>The bar representing VIA is displayed only if F 109 = 1 or 2</p>
0. 1	[Relay map]	 <p>ON: / OFF: ,</p>
t 0. 10	[Drive run time 100h]	Cumulative drive run time. 0.01 = 1 hour. 1.00 = 100 hours

I/O Map

In both the monitoring mode and the detected fault history, it is possible to view the state of the logic inputs and the relay outputs. See previous tables on pages 20 and 21.

Logic Input Map

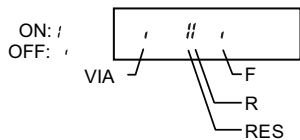

The ON or OFF status of each logic input is displayed in bits. VIA is included in this display if parameter **F 109** is set to either 1 or 2.

Relay Output Map

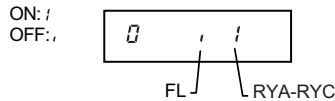

The ON or OFF status of each relay output is displayed in bits.

Run Mode

To access the Run mode, press the MODE key until the drive operating frequency, a detected fault code, or a pre-alarm code is displayed.

See Diagnostics and troubleshooting beginning on page [179](#) for the detected fault and pre-alarm codes.

Changing the Display in Run Mode

Motor operating frequency is the default value displayed on the graphic terminal in Run mode. This displayed value can be changed by setting parameter [\[Displayed param.\] \(F 7 1 D\)](#). See page [130](#) for a list of the display choices.

The displayed value can be expressed as a percentage of the drive rating, or in amperes or volts, as appropriate for the value displayed. The units can be changed by setting parameter [\[Unit value selection\] \(F 7 D 1\)](#) (see page [130](#)).

In addition, the resolution of the speed reference and output frequency displays can be adjusted by setting parameters [\[Loc. speed ref. step\] \(F 7 D 7\)](#) and [\[Display ref. resol.\] \(F 7 D B\)](#) (see pages [87](#) and [130](#)).

Programming Mode

Use this mode to program the drive.

To access the Programming mode, use the MODE key until the PRG indicator LED on the display is illuminated.

See Menu Navigation page [24](#).

Menu Navigation

Menu navigation diagrams below illustrate how to navigate through the programming menus and submenus.

A U H [Quick menu] submenu

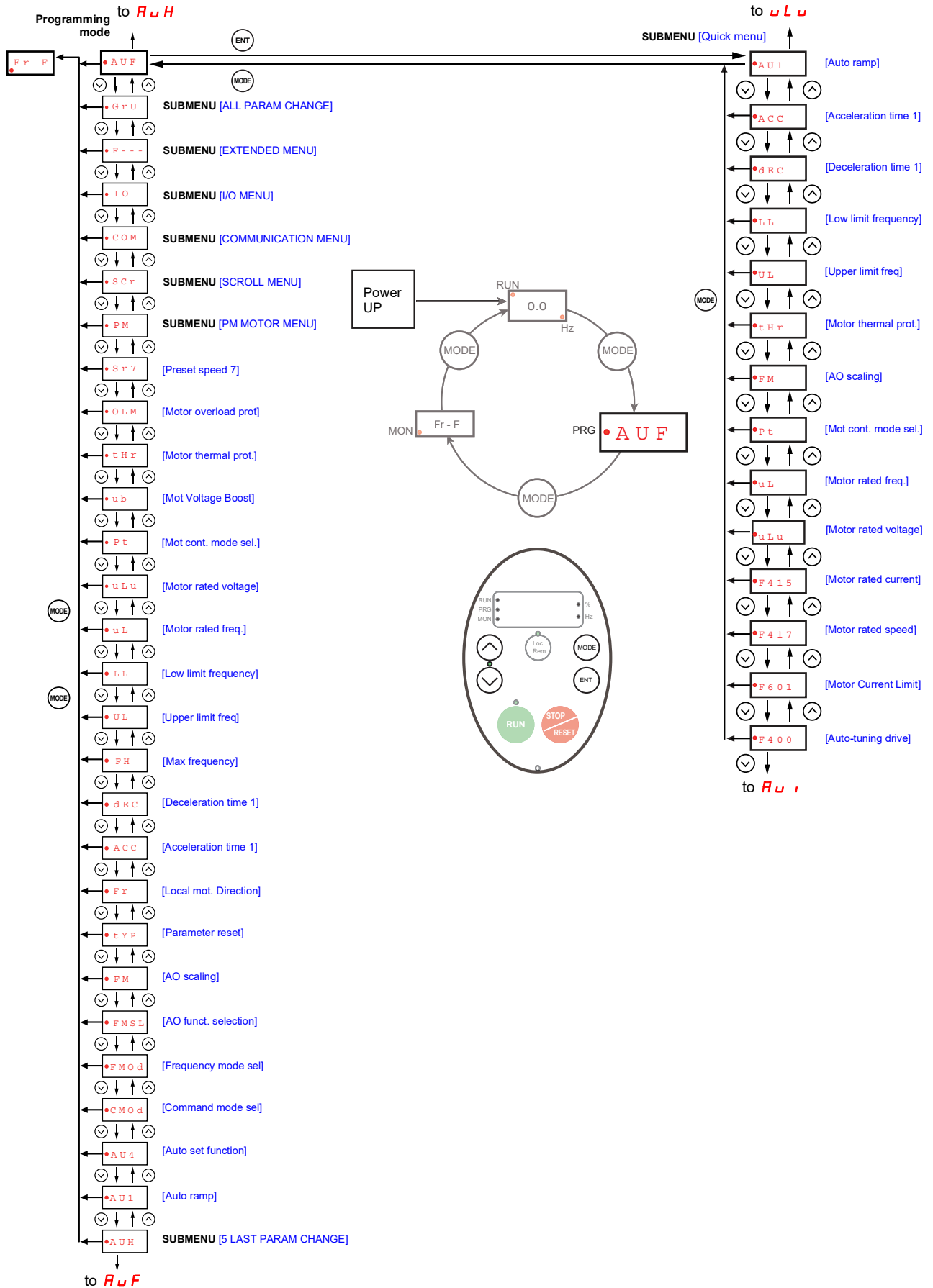

Fr-F [5 LAST PARAM CHANGE] submenu

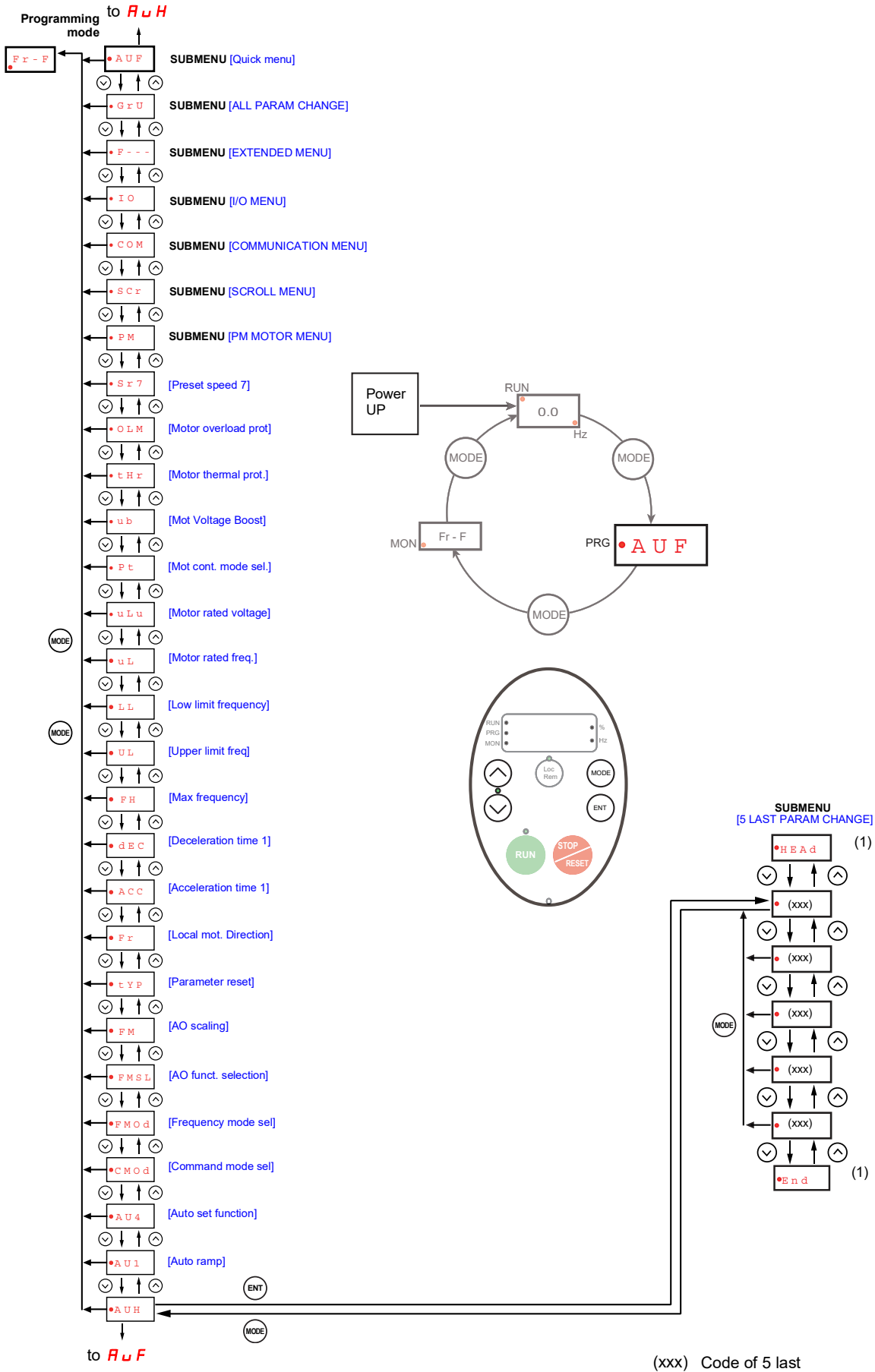

Note: If no parameter has been changed, **Fr-I** is selected.

(1) Flashes three times then displays previous parameter.

(xxx) Code of 5 last parameters

GrU [ALL PARAM CHANGE] submenu

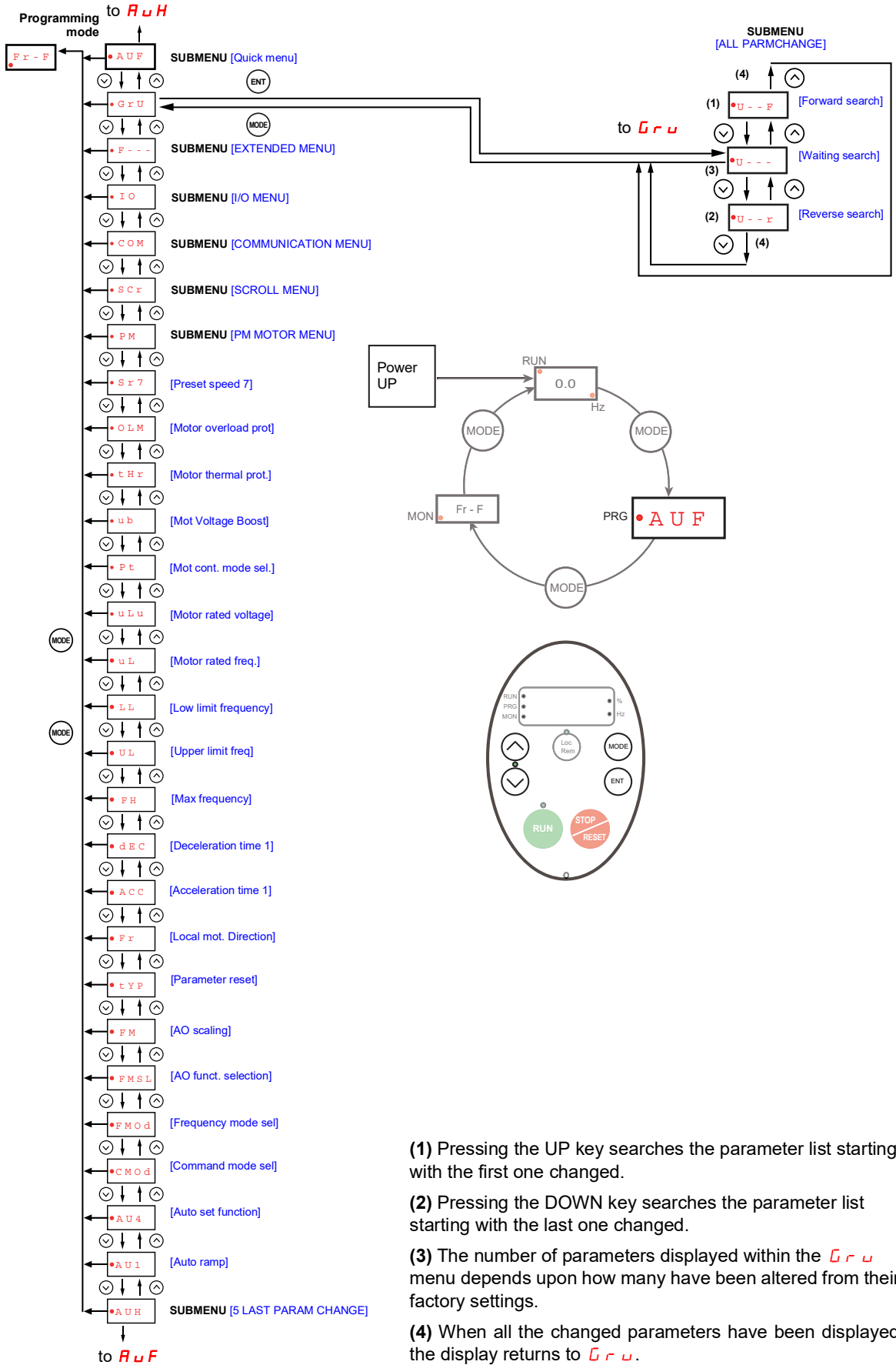

- (1) Pressing the UP key searches the parameter list starting with the first one changed.
- (2) Pressing the DOWN key searches the parameter list starting with the last one changed.
- (3) The number of parameters displayed within the **GrU** menu depends upon how many have been altered from their factory settings.
- (4) When all the changed parameters have been displayed, the display returns to **GrU**.

F - - - [EXTENDED MENU] submenu

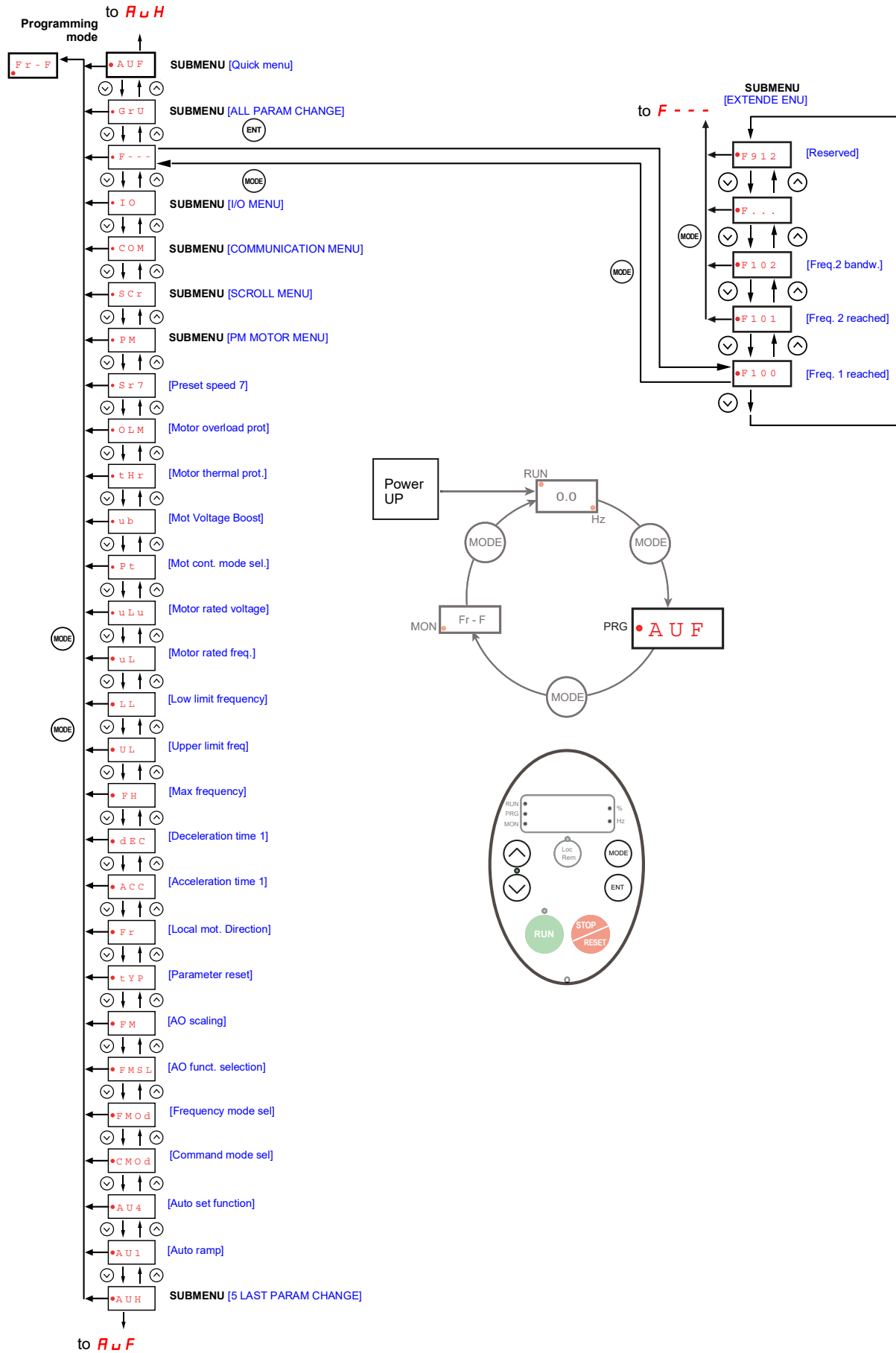

Fr-F [I/O MENU] submenu

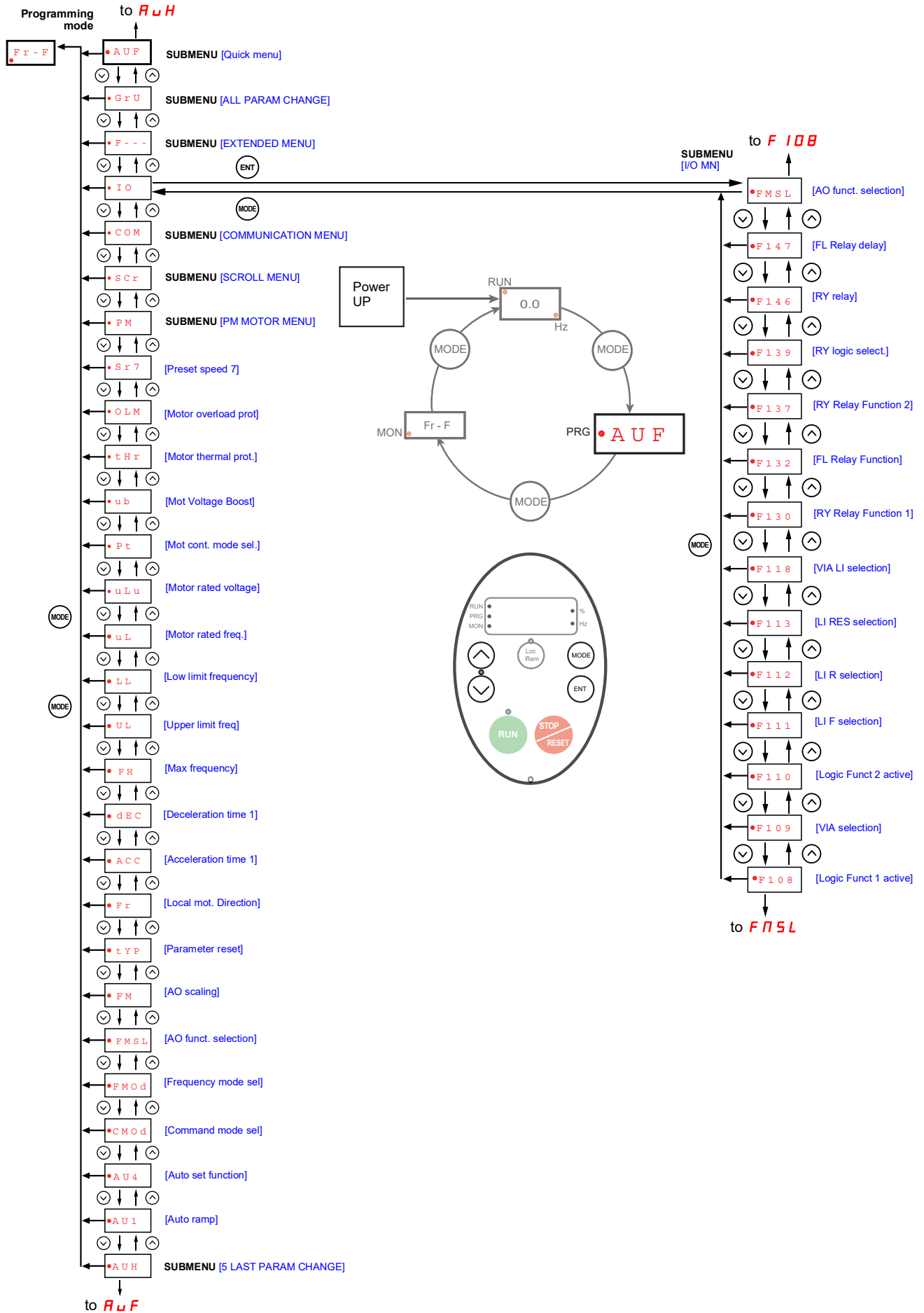

C o n [COMMUNICATION MENU] submenu

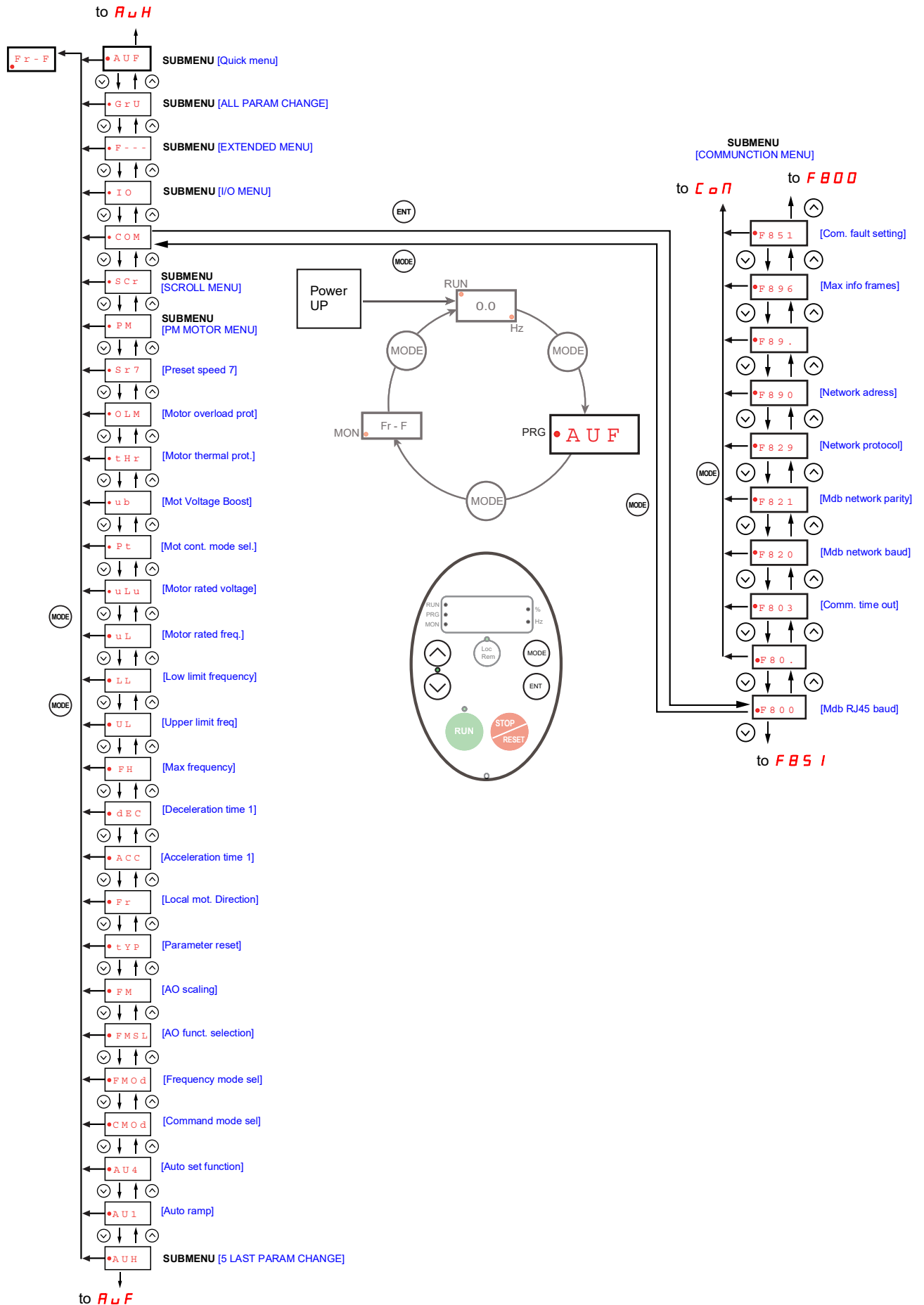

5 C r [SCROLL MENU] submenu 2

Programming to **A u H**
mode

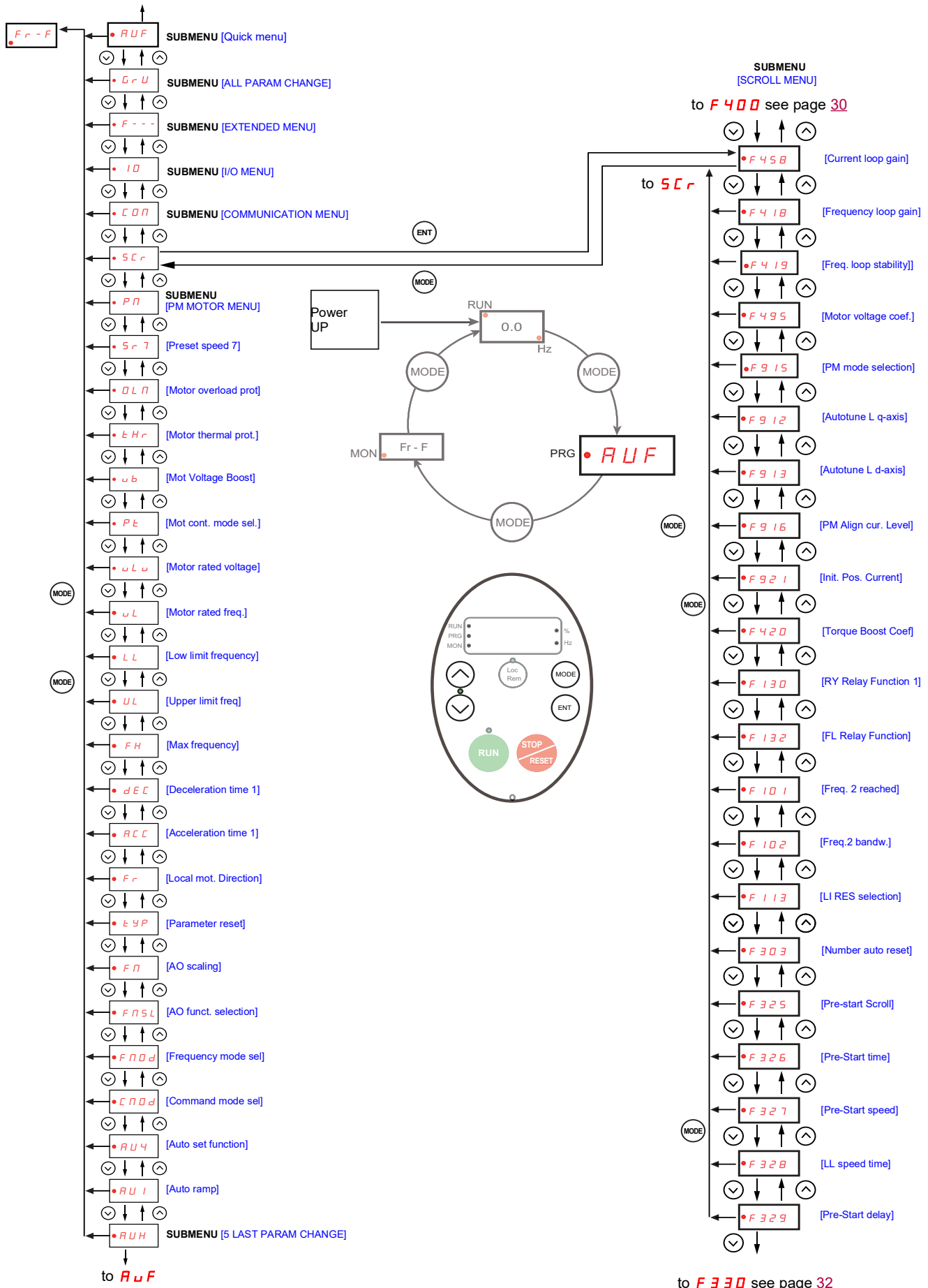

5 C r [SCROLL MENU] submenu 3

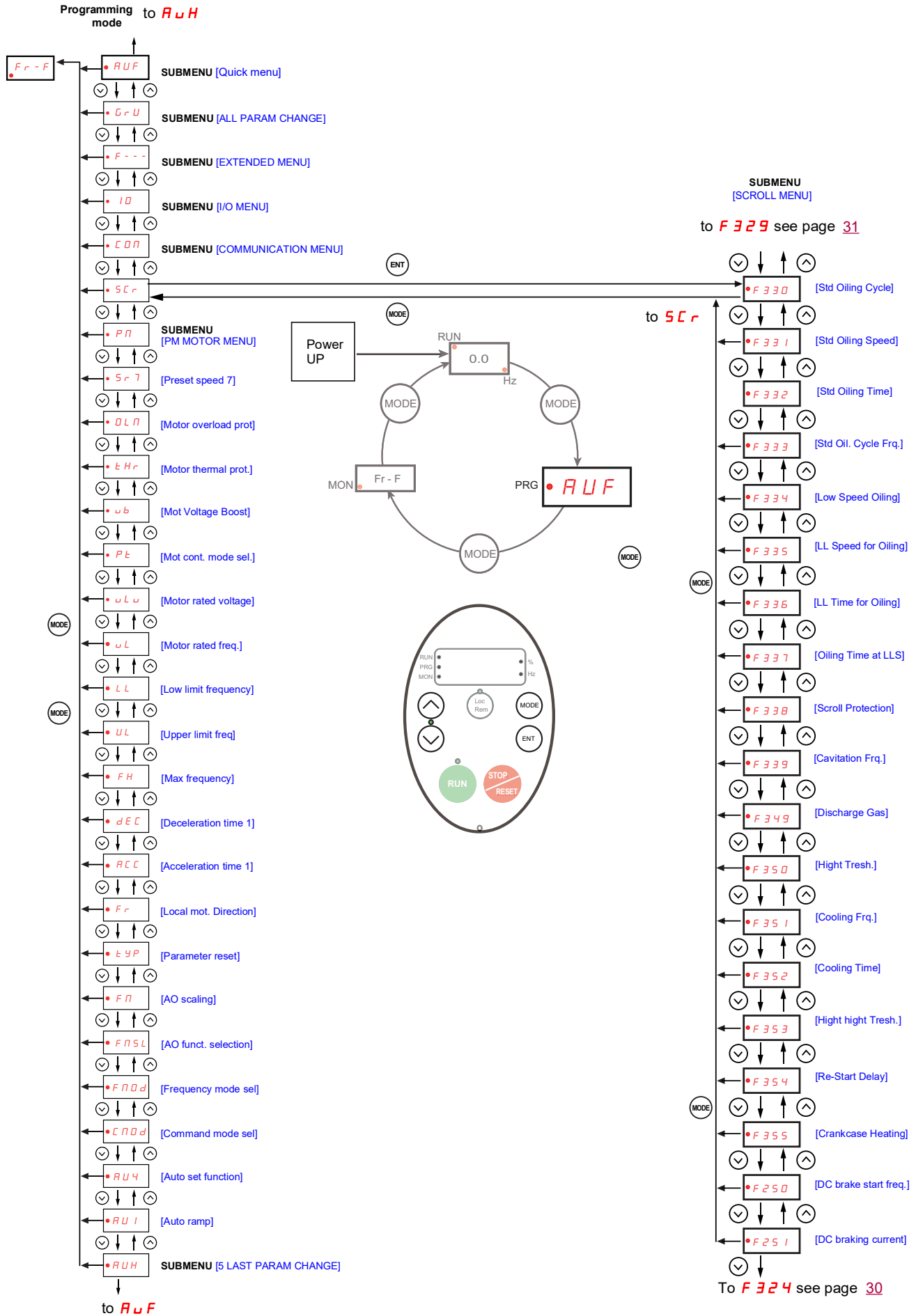

Pn [PM MOTOR MENU] submenu

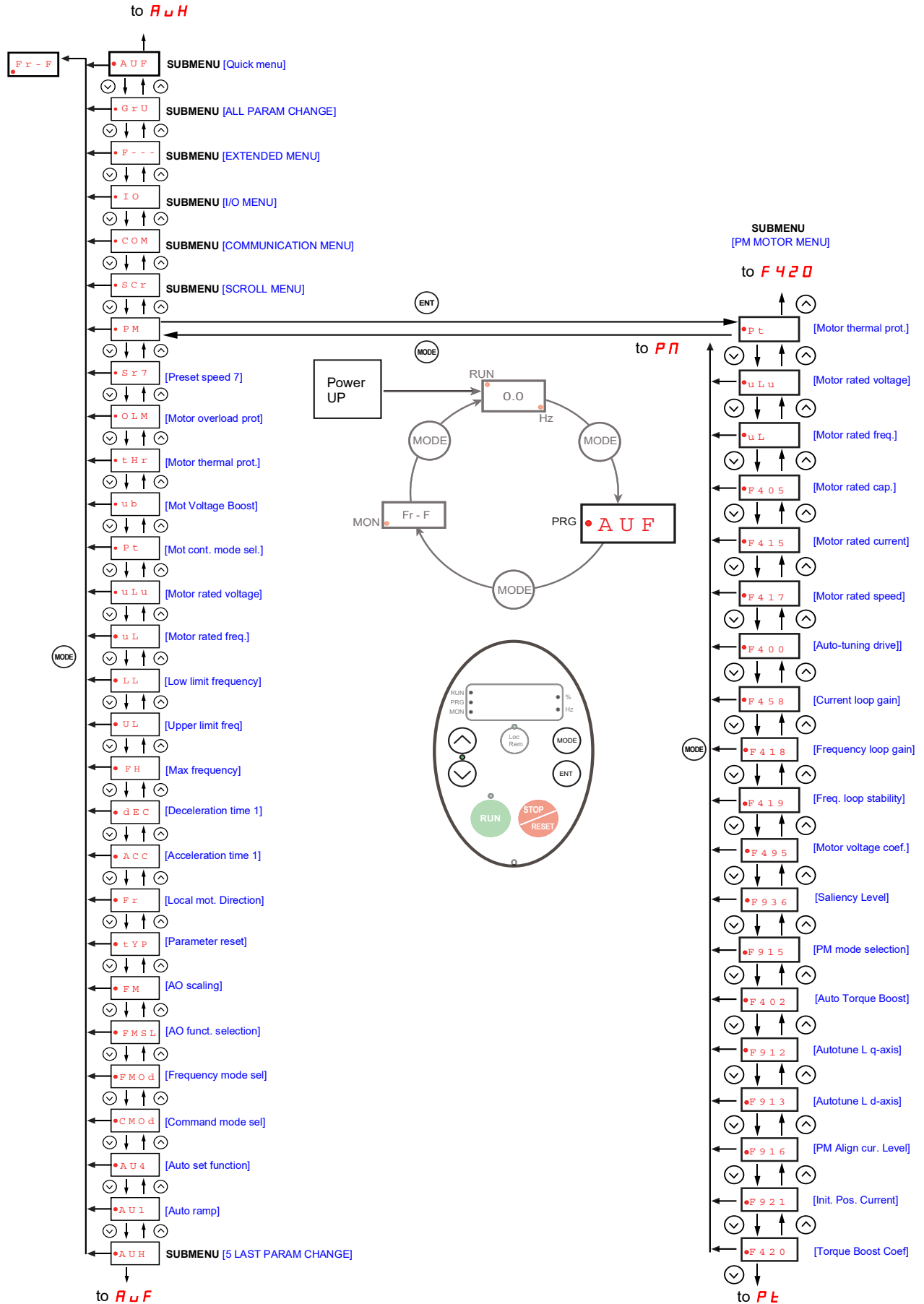

Submenus

The ATV212 drive features 6 submenus (see diagrams starting on page [24](#)) that are designed to reduce the time and effort required to program application parameters. Parameters can be modified within these submenus.

A **U** **H** [5 LAST PARAM CHANGE]

The **A U H** submenu displays, in reverse chronological order, the last 5 parameters that have been changed from their factory settings. Each time the **A U H** submenu is accessed, it searches for the latest parameters changed from their factory settings. If every parameter is at its factory settings, no display is generated.

Parameter Lock **F 7 0 0** is not displayed in the **A U H** menu, even if its value has been changed (see page [68](#)).

A **U** **F** [QUICK MENU]

The **A U F** submenu provides ready access to the ten basic parameters commonly used in programming the drive. In many cases, programming the ATV212 drive is complete when these 10 parameters have been properly set (see chapter Quick Menu page [59](#)).

G **R** **U** [ALL PARAM CHANGE]

The **G R U** submenu displays every parameter that has been changed from its factory settings. Each time the **G R U** submenu is accessed, its content is refreshed with the latest list of parameters changed from their factory settings. If every parameter is at its factory setting, no display is generated.

Parameters **F n** and **F 4 7 0 – F 4 7 3** are not displayed in the **G R U** menu, even if their values have been changed.

F **---** [EXTENDED MENU]

The extended parameter submenu provides access to parameters used for special settings and applications.

I **O** [I/O MENU]

The **I O** submenu provides access to parameters used for input/output setting.

C **O** **M** [COMMUNICATION MENU]

The **C O M** submenu provides access to parameters used for the communication setting.

S **C** **R** [SCROLL MENU]

The **S C R** submenu provides access to parameters used for the Synchronous scroll motors setting.

P **M** [PM CONTROL MENU]

The **P M** submenu provides access to parameters used for the Synchronous motor setting.

Graphic display option

⚠ WARNING

LOSS OF CONTROL

- Do not use the ATV21 and ATV12 terminal display (VW3A21101 and VW3A1006).
- Only VW3A1101 is compatible with ATV212.

Failure to follow these instructions can result in death, serious injury, or equipment damage.

Description of the graphic display option

With the graphic display option, which works with FLASH V1.1IE29 or higher, it is possible to display more text information than can be shown on the integrated display terminal.

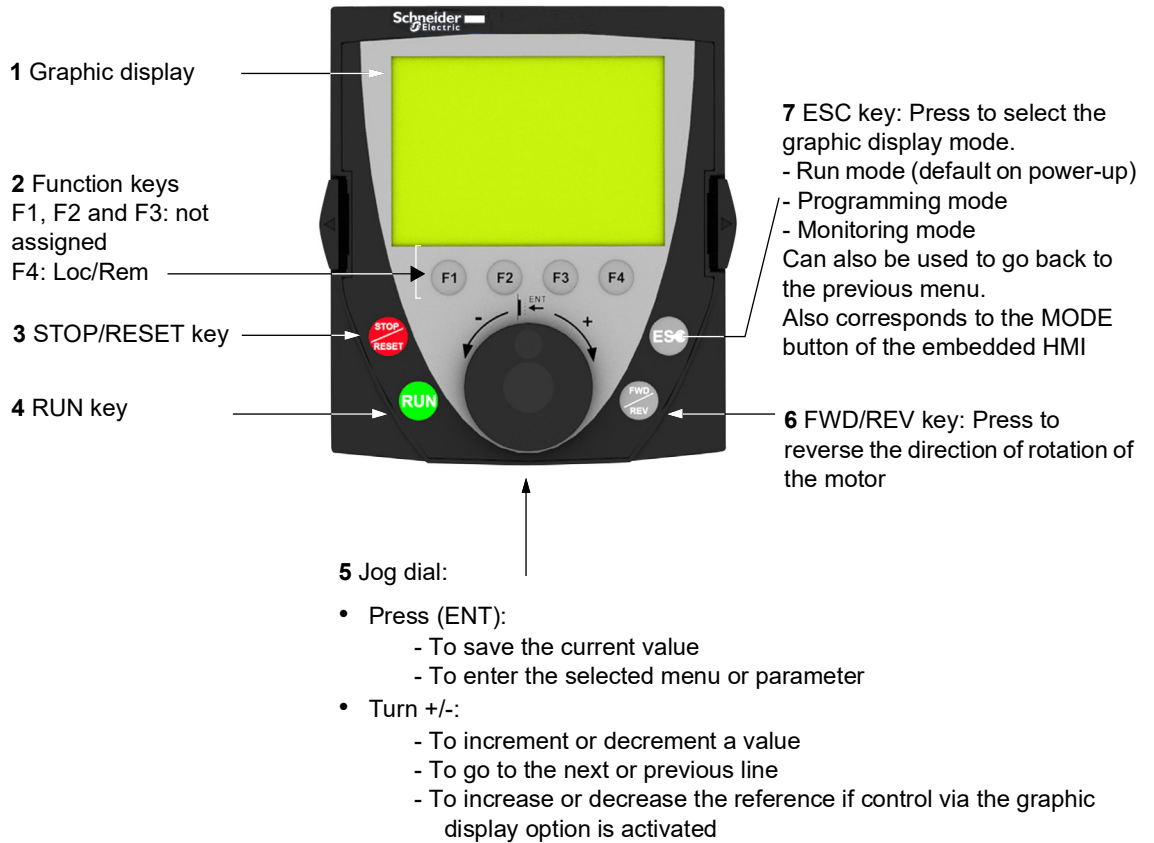

Note: Keys **3**, **4**, **5** and **6** can be used to control the drive directly, if control via the graphic display option is activated.

Powering up the drive with graphic display option for the first time

When powering up the graphic display option for the first time, the user has to select the required language.

LANGUAGE
English
Français
Deutsch
Italiano
Español
Chinese
Русский
Türkçe

Display after the graphic display option has been powered up for the first time. Select the language and press ENT.

↓ ENT



MAIN MENU
DRIVE MENU
LANGUAGE

ENT

LANGUAGE
English ✓
French
Spanish
German
Chinese

↓ The graphic display option to drive synchronization screen will now appear.

Move up/down keys ↑

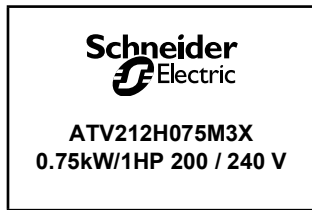

MAIN MENU
DRIVE MENU
LANGUAGE

2 s or ENT ↓

OPERATIONAL VALUE
0 Hz
Rem Loc/Rem

Finding a parameter in this document

The following assistance with finding explanations on a parameter is provided:

- With the integrated display terminal and the optional graphic display terminal : Direct use of the parameter code index, page [203](#), to find the page giving details of the displayed parameter.
- With the graphic display option: The parameter code and the name are displayed.

Example: ACC

AUF: QUICK MENU	
vLv: Motor rated voltage	
AU1: Auto ramp	
ACC: Acceleration time 1	
DEC: Deceleration time 1	
LL: Low limit frequency	
Rem	Loc/Rem

Then use the parameter code index, page [203](#), to find the page giving details of the displayed parameter.

Detected fault screens

Example: Output phase loss fault

EPHO: Output phase loss fault	
Loss of one or more output phases. Determine the cause of the missing output phase and rectify the problem. Set parameter F605 to 0.	
Rem	Loc/Rem

This screen is displayed the detected fault type and diagnostic information related to the detected fault. Then use the alarm code table page [180](#) for more information.

Line undervoltage

OPERATIONAL VALUE	
MOFF: Line Undervolt fault	
Rem	Loc/Rem

Pre-alarms screens

Here some type of screens:

Current Limit pre-alarm

Alarm C	
OPERATIONAL VALUE	
29.0 Hz	
Rem	Loc/Rem

DC bus overvoltage pre-alarm

Alarm P	
OPERATIONAL VALUE	
29.0 Hz	
Rem	Loc/Rem

Motor overload pre-alarm

Alarm L	
OPERATIONAL VALUE	
29.0 Hz	
Rem	Loc/Rem

Drive overheating pre-alarm

Alarm H	
OPERATIONAL VALUE	
29.0 Hz	
Rem	Loc/Rem

Current Limit and DC bus overvoltage pre-alarm

Alarm C	Alarm P
OPERATIONAL VALUE	
29.0 Hz	
Rem	Loc/Rem

Motor overload and drive overheating pre-alarm

Alarm L	Alarm H
OPERATIONAL VALUE	
29.0 Hz	
Rem	Loc/Rem

Modbus communication status

[Mdb com stat] (ПБ111) parameter display

This parameter is able to check the modbus communication on RJ45 and OpenStyle port.

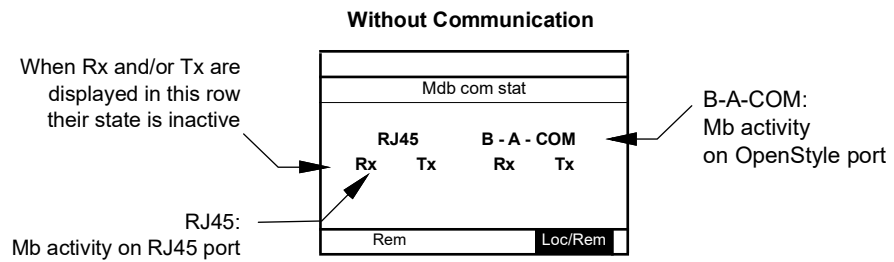

Example : With Communication on RJ45 port

Mdb com stat			
RJ45		B - A - COM	
Rx	Tx	Rx	Tx
Rem	Loc/Rem		

Mdb com stat			
RJ45		B - A - COM	
Rx	Tx	Rx	Tx
Rem	Loc/Rem		

SoMove software

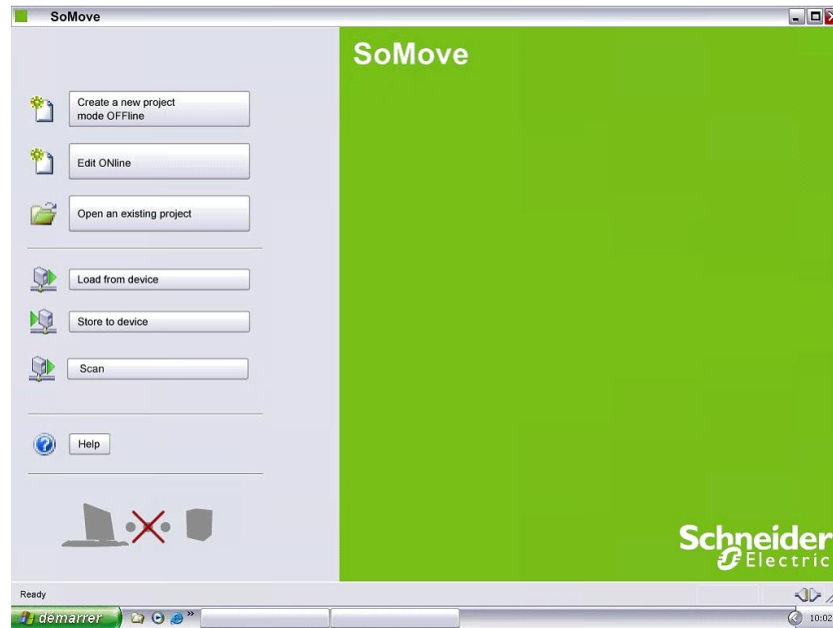

Description

SoMove is user-friendly setup software PC for setting up Altivar 212 drives.

SoMove software incorporates various functions for the device setup phases, such as:

- Configuration preparation
- Start-up
- Maintenance

It can be downloaded free of charge from the internet at www.se.com.

Connection

SoMove software can use a direct USB/RJ45 cable link or a Bluetooth® wireless link. See catalog on www.se.com.

Structure of the parameter tables

The parameter tables contained in the descriptions of the various menus are organized as follows.

Example:

Code	Name / Description	Adjustment range	Factory setting
F 4 0 0	[Auto-tuning drive] Auto tuning enable	-	0
0	[Disabled]		
1	[Initialize constant]: Application of individual settings of Auto Torque Boost [Auto Torque Boost] (F 4 0 2)		
2	[Complete tune]: complete auto tuning. Parameter F 4 0 0 is reset to "0" after the auto tuning is performed.		

- Value of parameter on graphic display option
- Parameter value on embedded display
- Name of parameter on graphic display option and description if needed.
- Parameter code on 4-digit 7-segment display

Note: The text in square brackets [] indicates what you will see on the graphic display option.

Parameters that cannot be changed while the drive is running

The table below lists the parameters that cannot be changed unless the drive is stopped.

Code	Description	Code	Description
A u 1	[Auto ramp]	F 3 3 8	[Scroll Protection]
A u 4	[Auto set function]	F 3 4 9	[Discharge gas]
C m o d	[Command mode sel]	F 3 5 5	[Crankcase heating]
F m o d	[Frequency mode sel]	F 4 0 0	[Auto-tuning drive]
t y P	[Parameter reset]	F 4 0 5	[Motor rated cap.]
F H	[Max frequency]	F 4 1 5	[Motor rated current]
u L	[Upper limit freq]	F 4 1 6	[Mot no-load current]
u L u	[Motor rated voltage]	F 4 1 7	[Motor rated speed]
P t	[Mot cont. mode sel.]	F 4 1 8	[Frequency loop gain]
F 1 0 8	[Logic Funct 1 active]	F 4 1 9	[Freq. loop stability]
F 1 0 9	[VIA selection]	F 4 5 8	[Current loop gain]
F 1 1 0	[Logic Funct 2 active]	F 4 8 0	[No load cur. coef]
F 1 1 1	[LI F selection]	F 4 8 1	[In noise comp. filter]
F 1 1 2	[LI R selection]	F 4 8 2	[In noise inhibit filter]
F 1 1 3	[LI RES selection]	F 4 8 3	[In noise inhibit gain]
F 1 1 8	[VIA LI selection]	F 4 8 4	[Pwr supply adj. gain]
F 1 3 0	[RY Relay Function 1]	F 4 8 5	[Stall control coef. 1]
F 1 3 2	[FL Relay Function]	F 4 9 2	[Stall control coef. 2]
F 1 3 7	[RY Relay Function 2]	F 4 9 4	[Mot. adj coefficient]
F 1 3 9	[RY logic select.]	F 4 9 5	[Motor voltage coef.]
F 1 7 0	[Mot 2 rated Freq.]	F 4 9 6	[PWM adj. coef.]
F 1 7 1	[Motor 2 rated Volt]	F 6 0 1	[Motor Current Limit]
F 3 0 0	[Switch. freq. level]	F 6 0 3	[fault stop Mode]
F 3 0 1	[Catch on fly]	F 6 0 5	[Output phase loss]
F 3 0 2	[Supply loss behav.]	F 6 0 8	[Input phase loss]
F 3 0 3	[Number auto reset]	F 6 1 3	[Short circuit det.]
F 3 0 5	[Overvoltage fault]	F 6 2 6	[Overvoltage level]
F 3 0 7	[Mot volt limitation]	F 6 2 7	[Undervolt detect.]
F 3 1 1	[Motor direction]	F 7 3 2	[Loc/rem key]
F 3 1 6	[Switch. freq. mode]	F 9 1 5	[PM mode selection]
F 3 2 4	[Driving Scroll]	F 9 1 6	[PM Align cur. Level]
F 3 2 5	[Pre-start Scroll]	F 9 2 0	[Position Adjust]
F 3 3 0	[Std Oiling Cycle]	F 9 2 1	[Init. Pos. Current]
F 3 3 4	[Low Speed Oiling]		

Common control schemes

⚡ ⚠ DANGER

HAZARD OF ELECTRIC SHOCK, EXPLOSION OR ARC FLASH
 Read and understand the instructions in "before you begin" chapter, before performing the procedure in this section.
Failure to follow these instructions will result in death or serious injury.

⚠ DANGER

UNINTENDED EQUIPMENT OPERATION

- To modify the setting of the switches, the product must be switched off.
- Do not change the setting of switch SW102 unless your system is properly wired.

Failure to follow these instructions will result in death or serious injury.

2-wire control

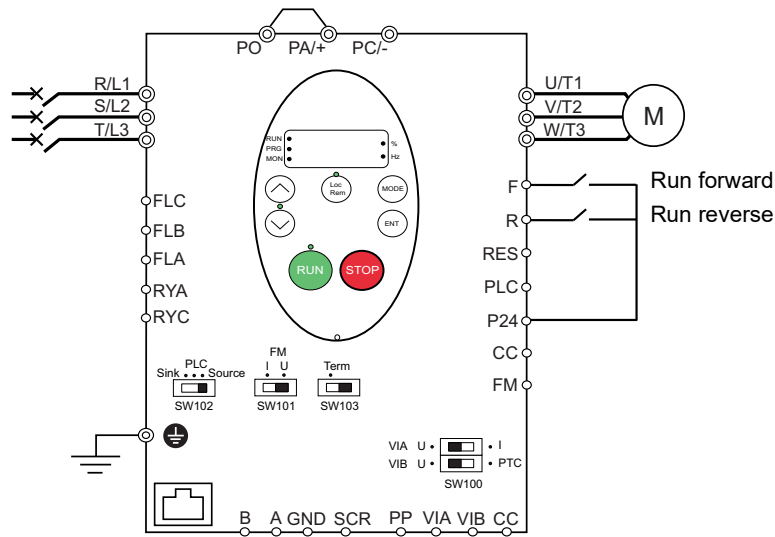

1. Wire the logic inputs as indicated in the above figure.
2. Set switch SW102 to source.
3. Program common parameters of ATV212 (see Quick Menu page 59).
4. Program specific parameters for 2-wire control as indicated in the following table:

Parameter	Page	Setting	Factory value
C P a d [Command mode sel]	87	0 [Logic inputs]	0
F I I 1 [LI F selection]	100	2 [forward]	2
F I I 2 [LI R selection]	100	3 [reverse]	6

Note: If **F I I 1** and **F I I 2** are switched simultaneously, the drive will go at 0 speed.

3-wire control

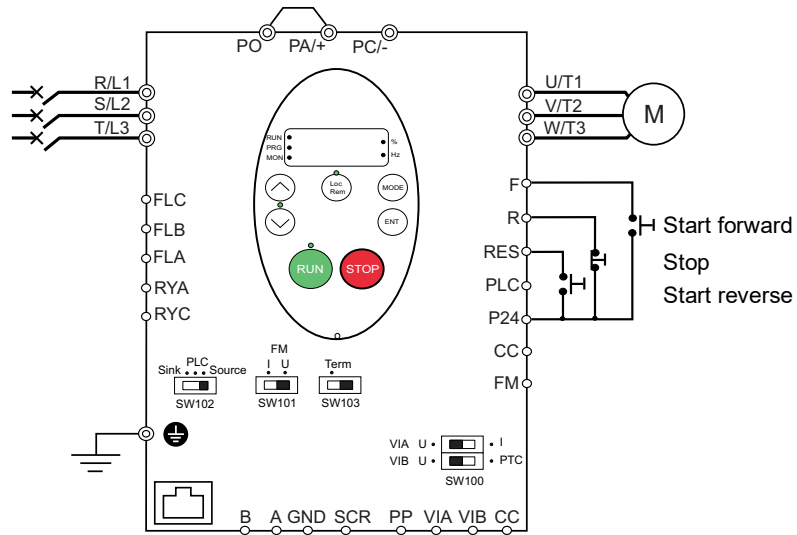

1. Wire the logic inputs as indicated in the above figure.
2. Set switch SW102 to source.
3. Program common parameters of ATV212 (see Quick Menu page 59).
4. Program specific parameters for 3-wire control as indicated in the following table:

Parameter	Page	Setting	Factory value
C P 0 d [Command mode sel]	87	0 [Logic inputs]	0
F 1 1 1 [LI F selection]	100	2 [forward]	2
F 1 1 2 [LI R selection]	100	4 9 [3-wire]	6
F 1 1 3 [LI RES selection]	100	3 [reverse]	10

3 wire control timing diagram

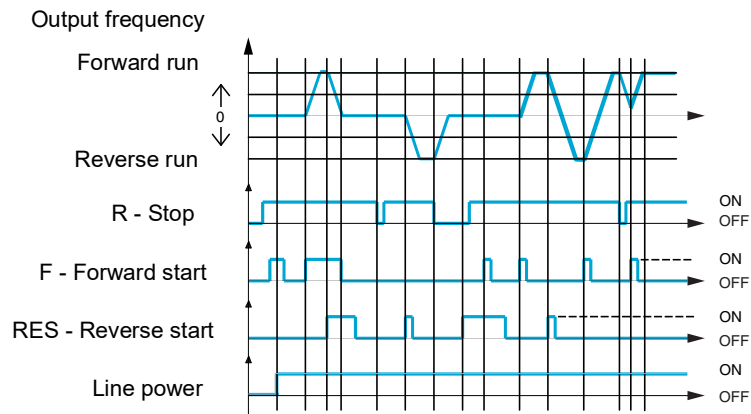

External speed control potentiometer

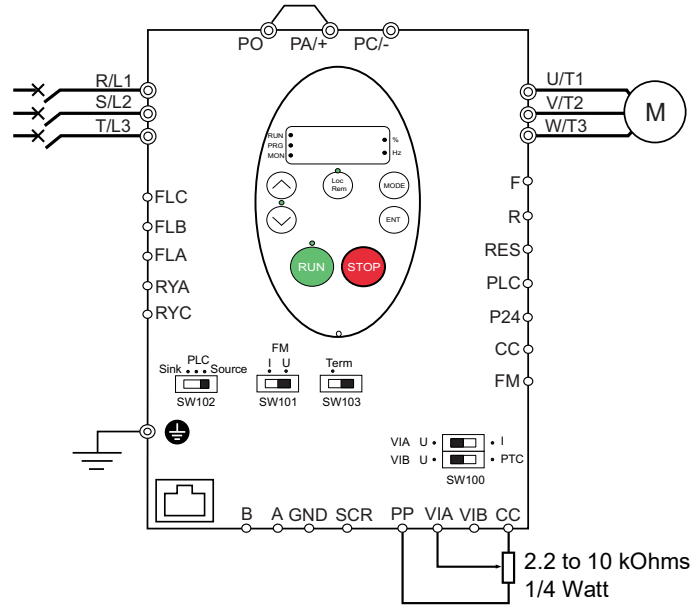

1. Wire the analog input as indicated in the above figure.
2. Set switch SW100 to V (voltage).
3. Program common parameters of ATV212 (see Quick Menu page 59).
4. Program specific parameters for external speed control potentiometer as indicated in the following table:

Parameter	Page	Setting	Factory value
F 0 0 [Frequency mode sel]	87	1 [Ref source VIA]	1
F 1 0 9 [VIA selection]	100	0 [AI]	0
F 2 0 0 [Auto/man speed ref]	118	0 [Enable]	0

4-20 mA speed control

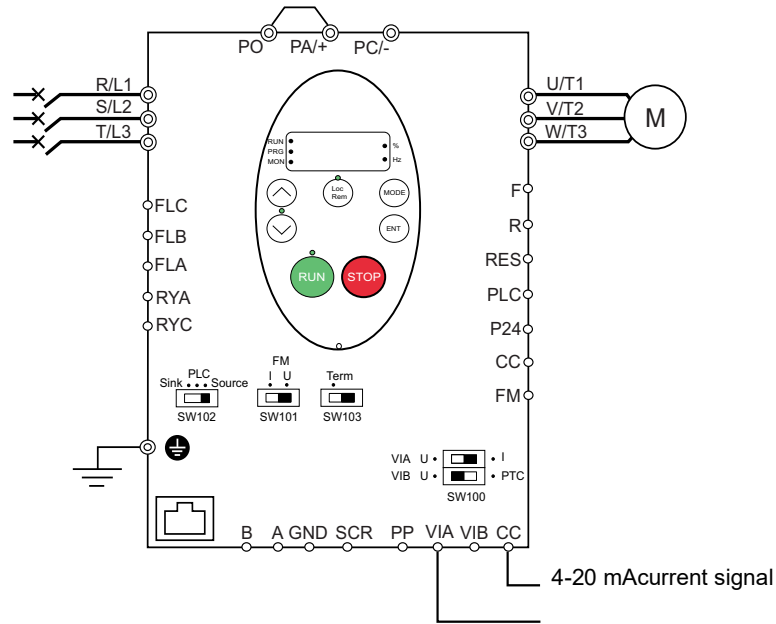

1. Wire the analog input as indicated in the above figure.
2. Set switch SW100 to I (current).
3. Program common parameters of ATV212 (see Quick Menu page 59).
4. Program specific parameters for 4-20 mA speed control as indicated in the following table:

Parameter	Page	Setting	Factory value
F 0 0 [Frequency mode sel]	<u>87</u>	I [Ref source VIA]	1
F 1 0 9 [VIA selection]	<u>100</u>	0 [AI]	0
F 2 0 0 [Auto/man speed ref]	<u>118</u>	0 [Enable]	0
F 2 0 1 [VIA ref point 1]	<u>116</u>	20 %	0 %

Preset speeds (up to seven)

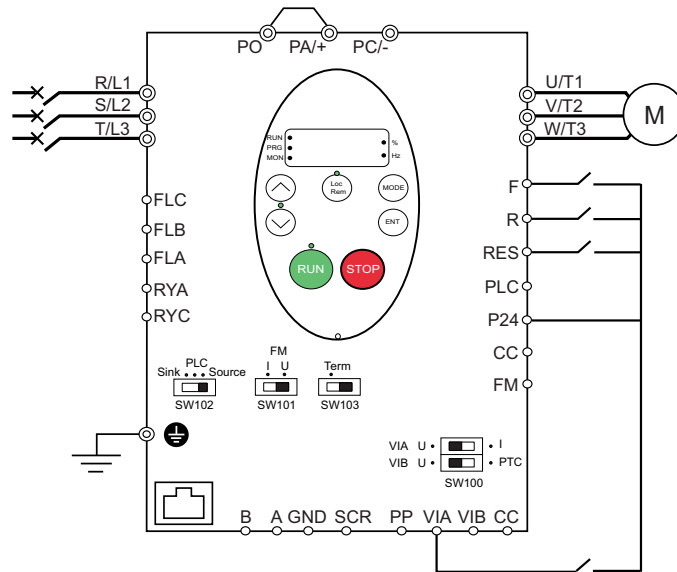

1. Wire the logic and analog inputs as indicated in the above figure.
2. Set switch SW102 to source.
3. Program common parameters of ATV212 (see Quick Menu page 59).
4. Program specific parameters for preset speed as indicated in the following table:

Parameter	Page	Setting	Factory value
F 109 [VIA selection]	100	2 [LI source]	0
F 111 [LI F selection]	100	2 [forward]	2
F 112 [LI R selection]	100	6 [PS1]	6
F 113 [LI RES selection]	100	7 [PS2]	10
F 118 [VIA LI selection]	100	8 [PS3]	7
S r 1 [Preset speed 1]	123	-	15.0
S r 2 [Preset speed 2]	123	-	20.0
S r 3 [Preset speed 3]	123	-	25.0
S r 4 [Preset speed 4]	123	-	30.0
S r 5 [Preset speed 5]	123	-	35.0
S r 6 [Preset speed 6]	123	-	40.0
S r 7 [Preset speed 7]	123	-	45.0

Example of 7-step preset speed operation:

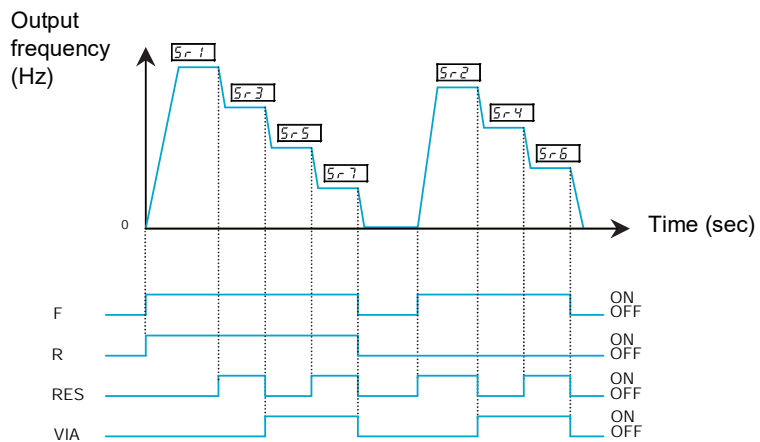

See page [123](#) for additional information.

Serial communication

RJ45 connection

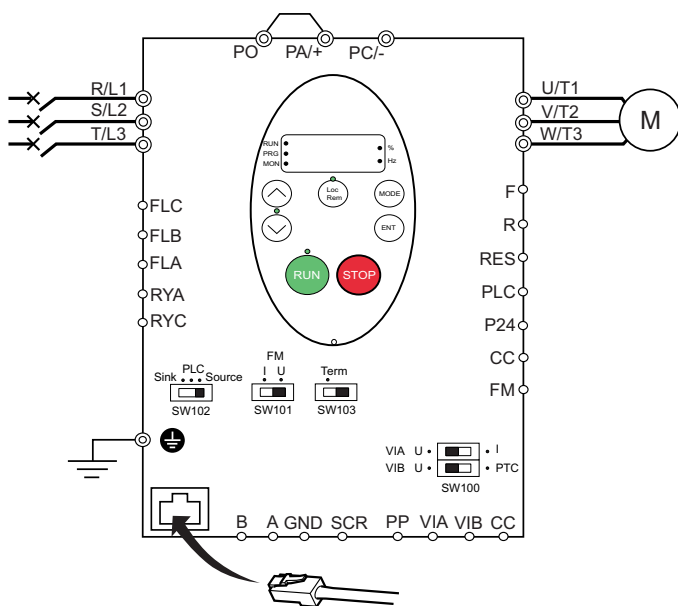

Port open style connection

Contact	Signal
B	+
A	-
GND	GND
SCR	Screen

- Cable sheath should be peeled off by about 10 mm.
- For wiring work, use a fat blade screwdriver with a 0.6 mm thick and 3.5 mm width blade.
- Tightening torque for the terminal block is 0.5 to 0.6 Nm.

1. For Modbus serial communication, plug the network cable into RJ45 connector on the main control board. Connection can also be carried out using the «open style» port.
2. Program common parameters of ATV212 (see Quick Menu page 59).
3. Program specific parameters for serial communication as indicated in the following table:

Parameter	Page	Setting	Factory value
C P a d [Command mode sel]	87	2 [Communication]	0
F P a d [Frequency mode sel]	87	4 [Serial com ref.]	1
F B 0 7 [Com channel choice]	149		1

Forced local

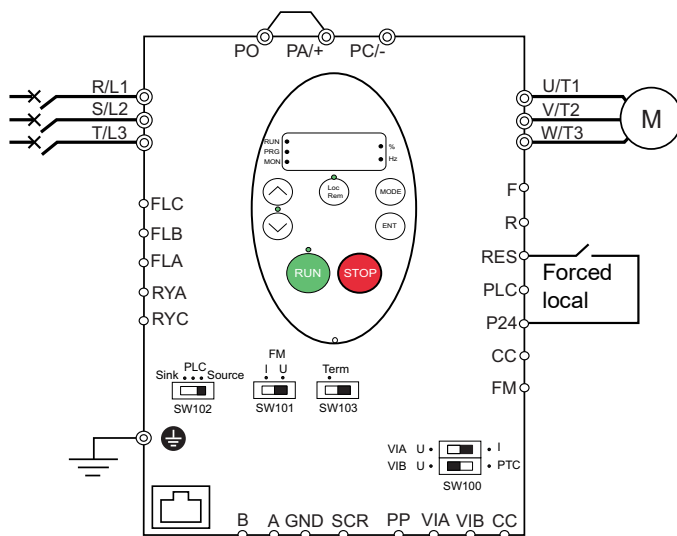

1. Wire the logic input as indicated in the above figure.
2. Set switch SW102 to source.
3. Program common parameters of ATV212 (see Quick Menu page 59).
4. Program specific parameter for forced local as indicated in the following table:

Parameter	Page	Setting	Factory value
F I I 3 [LI RES selection]	100	4B [forced local]	10

PID control

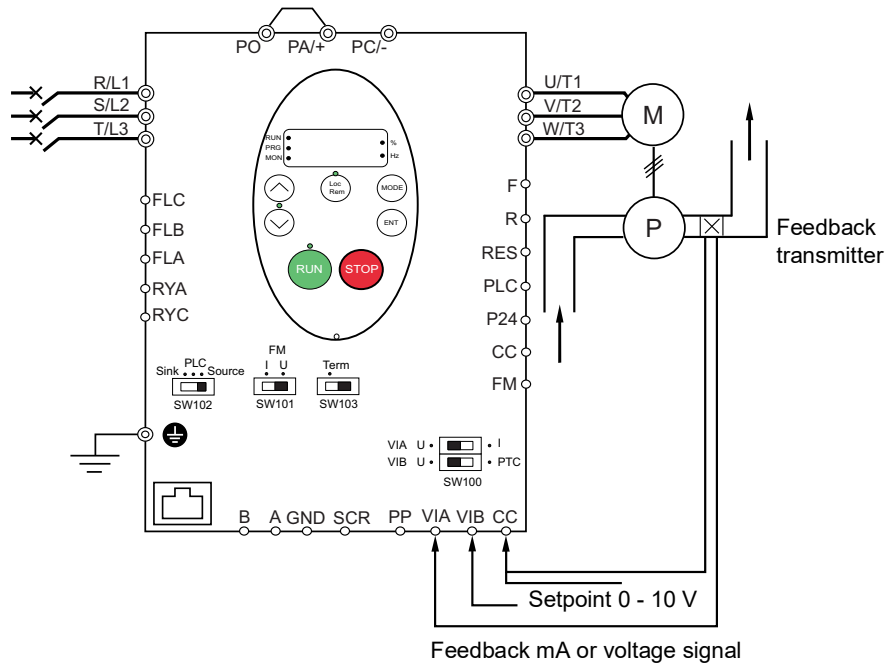

1. Wire analog inputs as indicated in the above figure.
2. Set switch SW102 to source.
3. If the feedback is a milliamp signal, set switch SW100 to the I (current) position. If the feedback is a voltage signal, set switch SW100 to the V (voltage) position.
4. Program common parameters of ATV212 (see Quick Menu page 59).
5. Program specific parameters for PID control as indicated in the following table:

Parameter	Page	Setting	Factory value
F 1 0 0 [Frequency mode sel]	87	2 [Communication]	1
F 1 0 9 [VIA selection]	100	0 [AI]	0
F 2 0 0 [Auto/man speed ref]	118	0 [Enable]	0
F 3 6 0 [PID control enable]	120	1 [PID by VIA]	0
F 3 5 9 [PID ctrl wait time]	121	In accordance with the application	0 s
F 3 6 2 [PID Prop Gain]	120		0.30 %
F 3 6 3 [PID Integral Gain]	120		0.20
F 3 6 6 [PID Derivative Gain]	121		0.00
F 3 8 0 [PID reverse error]	121		0
F 3 9 1 [Stop on LL hyst]	122		0.2 Hz
F 3 9 2 [PID wake up (thres)]	122		0.0 Hz
F 3 9 3 [PID wake up, feedb]	122		0.0 Hz

Drive Operation

Local and Remote Modes of Operation

Overview

The ATV212 drive has two modes of operation, local and remote.

In local mode, the ATV212 drive can be operated only from the embedded display terminal or graphic display option:

- Use the RUN and STOP keys for command control
- Use the UP and DOWN keys for speed control

In remote mode, the ATV212 drive is operated from a combination of the command and speed reference sources defined by programming parameters [\[Frequency mode sel\] \(F P o d\)](#) and [\[Command mode sel\] \(C P o d\)](#) (see page [87](#)).

Command Sources

The command source [\[Command mode sel\] \(C P o d\)](#) choices are:

- External signals to the control terminal logic inputs F, R, RES and VIA
- Serial communication control (Modbus®, Metasys® N2, Apogee® FLN P1, BACnet, or LonWorks®)
- Embedded display terminal RUN and STOP keys or graphic display option

Speed Reference Sources

The speed reference source [\[Frequency mode sel\] \(F P o d\)](#) choices are:

- External signals to the control terminal analog inputs VIA or VIB
- (4–20 mA, 0–10 Vdc),
- External signals to the control terminal logic inputs assigned to +/- Speed
- Serial communication control (Modbus®, Metasys® N2, Apogee FLN P1®, BACnet, or LonWorks®)
- Embedded display terminal UP and DOWN keys or graphic display option

Command Mode Selection and Priorities

The diagram below illustrates the control inputs and selection logic which determine the source of the drive's start/stop and speed reference commands.

Command and Reference Switching

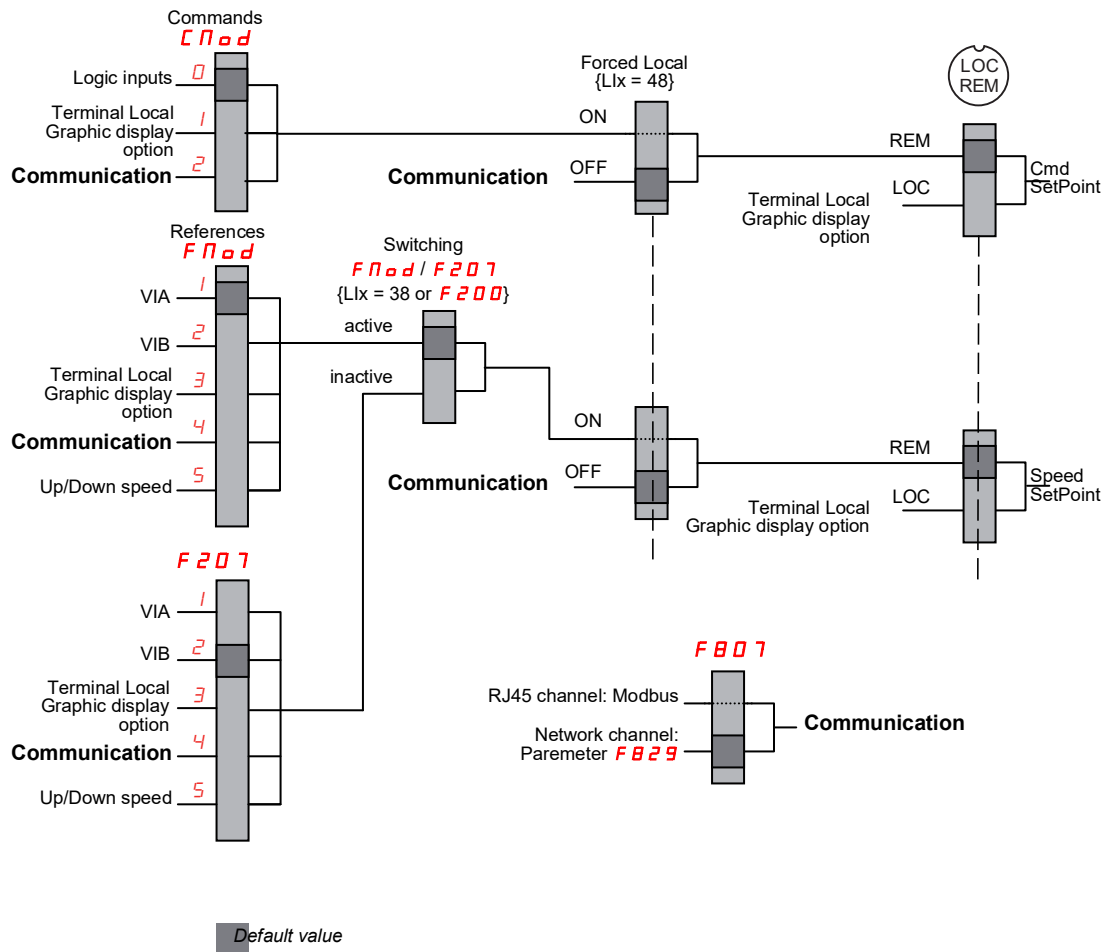

Parameters [\[Command mode sel\] \(Cn\)](#) and [\[Frequency mode sel\] \(Fn\)](#) are the first layers of logic used by the drive to determine its command Cn and speed reference Fn source.

[\[Remote spd ref 2\] \(F207\)](#) is a secondary speed reference source that may override the source selected by Fn (see page 87).

The speed reference source identified by F207 takes control if either:

- A logic input assigned to function 38 (frequency reference source switching) is enabled, or
- Parameter [\[Auto/man speed ref\] \(F200\)](#) is set to 1 and the drive's output frequency is equal to or less than 1 Hz (see page 118).

If a serial communication link is established, it can take control of the ATV212 drive, overriding inputs identified by Cn, Fn, and F207. Control is restored to Cn, Fn, and F207 only if:

- The serial communication link relinquishes control, or
- A logic input assigned to function 48 (forced local) is enabled.

The final layer of logic used by the drive to determine its command source is the LOC/REM key on the graphic display option.

When the drive and embedded HMI is set to local mode (by pressing the LOC/REM key, lighting the local mode LED), the drive responds only to commands from the embedded and graphic display option.

Selecting Local or Remote mode

⚠ DANGER

UNINTENDED EQUIPMENT OPERATION

- Know the state of the frequency and run commands from the remote source before exiting the local mode.
- Upon entering the remote mode, the drive will respond to the most recent command from the remote source, even if it was received before entering or while in the local mode.

Failure to follow these instructions will result in death or serious injury.

Switching between local and remote mode is achieved with the LOC/REM key on the drive's embedded display terminal or with F4 key on the graphic display option.

The LOC/REM key can be disabled by setting parameter [Loc/rem key] (F 7 3 2) to 1 (see page 90).

When parameter [Switch rem/Local] (F 2 9 5) is set to 1 (factory setting), a bumpless transfer of motor operation is achieved when switching from remote to local mode (see page 88).

For example, if the bumpless transfer feature is active and if the motor is running at full speed with the drive in remote mode, the motor will still run at full speed after the drive is transferred to local mode.

Conversely, when switching from local to remote mode, the run and speed command is not transferred to the remote mode. Upon entering the remote mode, the drive will operate on the run and speed command set by the remote source even if it was received before entering or while in the local mode.

The diagram below is an example timing diagram.

Switching Between Local and Remote Mode

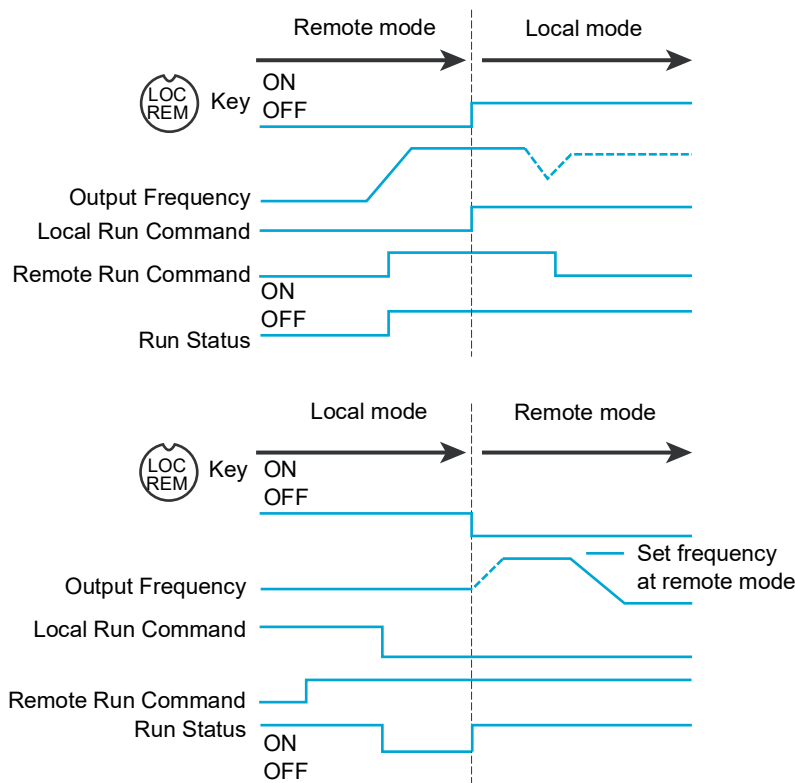

The remote run command and frequency command are transferred to the local mode when the LOC/REM key is pressed.

In this example, the run command and frequency command from the remote mode are copied to the local mode, and the motor continues to run.

When switching from the local mode to the remote mode, the run command and frequency command are determined by the setting in the remote mode.

In this example, when the LOC/REM button is pressed, the motor is started. This is due to the application of a remote run command when the drive exits the local mode and enters the remote mode.

Local Mode

When the ATV212 drive is in local mode, the LED above the LOC/REM key is illuminated.

On the graphic display option:

AUF: QUICK MENU			
LL: Low Limit frequency			
DEC: Deceleration time 1			
ACC: Acceleration time 1			
AU1: Auto ramp			
vLv: Motor rated voltage			
Loc	Ref loc	Cmd loc	Loc/Rem

Starting and Stopping the Motor in Local Mode

Start and stop the motor with the RUN and STOP keys on the graphic/embedded display terminals.

The setting of parameter [\[Loc. mot stop mode\]](#) (*F 7 2 1*) determines how the motor stops when the drive is in local mode (see page [88](#)):

- If *F 7 2 1* is set to 0 (factory setting), the motor will stop on a ramp, based on the time value set in parameter [\[Deceleration time 1\]](#) (*d E C*) or parameter [\[Deceleration time 2\]](#) (*F 5 0 1*).
- If *F 7 2 1* is set to 1, power will be removed from the motor when the STOP key is pressed, allowing the motor to coast to a stop with the ramp-down time determined by inertia and friction.

Use of the RUN and STOP keys in local mode can be disabled using parameter [\[Run/stop key\]](#) (*F 7 3 3*) (see page [90](#)).

Adjusting Motor Speed in Local Mode

Set the motor speed using the UP and DOWN keys on the graphic/embedded display terminals. Motor speed can be adjusted while the drive is operating.

Normally, motor frequency changes by 0.1 Hz each time the UP or DOWN key is pressed. This rate of speed change can be altered by entering a new frequency step change into parameter [\[Loc. speed ref. step\]](#) (*F 7 0 7*) (see page [87](#)).

If the ENT key is pressed after the motor speed has been adjusted, that speed setpoint value will be entered into parameter *F C*. The next time the drive is Power ON in local mode, it will accelerate the motor directly to the speed setpoint memorized by [\[Local speed ref.\]](#) (*F C*) (see page [87](#)).

Selecting Motor Rotation Direction in Local Mode

Motor rotation direction is set by parameter [\[Local mot. direction\]](#) (*F r*) (see page [87](#)). The four selections are:

- 0: Forward only (factory setting)
 - 1: Reverse only
 - 2: Forward, with reverse selectable from the graphic/embedded display terminals (1)
 - 3: Reverse, with forward selectable from the graphic/embedded display terminals (1)
- (1) If *F r* is set to either 2 or 3, motor rotation can be set to forward by pressing the UP key while holding the ENT key. Reverse can be set by pressing the DOWN key while holding the ENT key.

Motor rotation is indicated on the embedded display terminal as *F r - F* for forward and as *F r - r* for reverse.

The ability to run in the Forward or Reverse direction can be set with parameter [\[Motor direction\]](#) (*F 3 1 1*) (see page [96](#)).

Resetting drive detected fault in Local Mode

It is not possible to clear a drive detected fault if the cause of the detected fault persists. Be certain to diagnose and rectify the cause of the detected fault before attempting a drive reset.

With the STOP Key

To clear a drive detected fault in local mode:

1. Press the STOP key. See Fault detection codes that can be cleared with the automatic restart function after the cause has disappeared on page 135 for a list of detected faults that can be cleared with the STOP key. If it is possible to reset the drive, the embedded display terminal will display **CLr**.
2. To clear the detected fault, press the STOP key a second time.
3. If the cause of the detected fault is still present, the **CLr** display will not appear. Diagnose and clear the detected fault before attempting to reset the drive.

Use of the STOP key as a clear detected fault can be set with parameter [\[HMI reset button\] \(F 735\)](#) (see page 90).

In the event of an **OL1** or **OL2** detected fault, the following time periods are necessary before a clear detected fault is possible:

- **OL1** (drive overload)—about 30 seconds after the detected fault has occurred
- **OL2** (motor overload)—about 120 seconds after the detected fault has occurred

By Cycling Line Power

A drive detected fault can also be cleared by removing and restoring line power. Be certain that the cause of the detected fault is no longer present and leave power removed long enough for all of the LEDs on the face of the drive to extinguish.

Cycling power to clear a detected fault can cause the detected fault history to be lost. Refer to parameter [\[Drive Fault Memory\] \(F 602\)](#) on page 138.

Logic Input Functions Active in Local Mode

The logic input functions listed in the table below are active, even if [\[Command mode sel\] \(C 05\)](#) is set to 1 (embedded display terminal control). See table on page 100 for logic input function settings.

Logic Input Function No.	Description
1	[Run permissive]
54	[Inverse Run permissive]
10	[Fault reset]
55	[Inv fault reset]
11	[Ext Fault]
45	[Inv Ext. fault]
16	[Run reset]
38	[Frequency source]
41	[(+) speed]
42	[(-) speed]
43	[+/- clear]
44	[+/- SPD, FLT CLR]
46	[Ext. Th fault]
47	[Inv Ext. Th fault]
51	[Reset kWh]
52	[Forced mode]
53	[Fire mode]
62	[RY on]
64	[Cancel HMI cmd]

Remote Mode

When the ATV212 drive is in the remote mode, the LOC/REM LED is off.

Starting and Stopping the Motor in Remote Mode

The diagram on page 50 illustrates the start/stop command source when the drive is in remote mode.

With Logic Input Terminals

Use the logic input terminals F, R, RES, or VIA to start the drive if parameter [Command mode sel] (C P 0 d) is set to [Logic Inputs] (0) (factory setting).

With the display terminals

The drive responds to commands from the embedded display terminal or graphic display option, just as in local mode, if parameter [Command mode sel] (C P 0 d) is set to [HMI] (1).

With Serial Communication

The drive responds to commands sent over the serial communication link (Modbus[®], Metasys[®] N2, Apogee[®] FLN, BACnet or LonWorks[®]) if parameter [Command mode sel] (C P 0 d) is set to [Communication] (2).

The drive responds to commands sent over the RJ45 communication port if parameter [Com channel choice] (F B 0 7) is set to 0. Other protocols are available when F B 0 7 is set to 1 on open style port.

With the graphic/embedded display terminals STOP Key

The graphic/embedded display terminals STOP key is active when the drive is in remote mode. Pressing the STOP key causes the drive to stop according to the setting of parameters [Ext. fault stop Mode] (F 5 0 3), [DC brk time ext fit] (F 5 0 4), and [DC braking current] (F 2 5 1) (see page 126 and page 98). After the drive has come to a stop, the graphic/embedded display terminals display E and the fault relay is activated.

Adjusting the Motor Speed in Remote Mode

The diagram on page 50 illustrates the speed reference source when the drive is in remote mode.

By Analog Input VIA

A 0–10 Vdc or 4–20 mA signal connected to VIA and CC can be used to adjust the motor speed if:

- Parameter [Frequency mode sel] (F P 0 d) is set to 1 (factory setting).
- Alternate speed reference source parameter [Remote spd ref 2] (F 2 0 7) has not been enabled (see page 88).

The analog signal type depends on the setting of switch SW100 and parameters F 1 0 9, F 2 0 1–F 2 0 4, and F 4 7 0–F 4 7 1.

By Analog Input VIB

A 0–10 Vdc signal connected to VIB and CC can be used to adjust the motor speed if:

- Parameter [Frequency mode sel] (F P 0 d) is set to 2.
- Alternate speed reference source parameter [Remote spd ref 2] (F 2 0 7) has not been enabled.

The control that VIB has over motor speed depends on the setting of switch SW100 and parameters F 2 1 0–F 2 1 3, F 4 7 2–F 4 7 3, and F 6 4 5.

By display terminal Control

Control of the motor speed is enabled, if:

- Parameter [\[Frequency mode sel\]](#) (*F P o d*) is set to 3.
- Alternate speed reference source parameter [\[Remote spd ref 2\]](#) (*F 2 0 7*) has not been enabled.

By Serial communication control

Serial communication control (Modbus, Metasys N2, Apogee FLN, BACnet or LonWorks) of the motor speed is enabled, if:

- Parameter [\[Com channel choice\]](#) (*F B 0 7*) is set to 0 (only for Modbus on RJ45 port),
- Parameter [\[Com channel choice\]](#) (*F B 0 7*) is set to 1,
- Parameter [\[Frequency mode sel\]](#) (*F P o d*) is set to 4.
- Alternate speed reference source parameter [\[Remote spd ref 2\]](#) (*F 2 0 7*) has not been enabled.

By +/- Motor Speed Control

+/- Motor speed control is enabled, if:

- Parameter [\[Frequency mode sel\]](#) (*F P o d*) is set to 5,
- Alternate speed reference source parameter [\[Remote spd ref 2\]](#) (*F 2 0 7*) has not been enabled.

Selecting Motor Rotation Direction in Remote Mode

The diagram on page [50](#) illustrates the motor rotation command source when the drive is in remote mode.

With Logic Input Terminals

Use the logic input terminals F, R, RES, or VIA to select motor rotation direction if parameter [\[Command mode sel\]](#) (*C P o d*) is set to 0 (factory setting).

With the embedded display terminal or graphic display option

Motor rotation direction can be set by pressing the display terminal UP and ENT keys if:

- Parameter [\[Command mode sel\]](#) (*C P o d*) is set to 1,
- Serial communication control has not been established.
- Parameter [\[Local mot. direction\]](#) (*F r*) is set to either 2 or 3.

With Serial Communication

The drive responds to commands sent over the serial communication link (Modbus, Metasys N2, Apogee FLN, BACnet or LonWorks) if Parameter [\[Command mode sel\]](#) (*C P o d*) is set to 2.

Resetting drive detected faults in Remote Mode

The diagram on page [50](#) illustrates the clear detected fault command source when the drive is in remote mode.

It is not possible to clear a drive detected fault if the cause of the detected fault persists. Be certain to diagnose and rectify the cause of the detected fault before attempting to reset the drive.

See Automatically Resettable detected faults on page [135](#) for a list of detected faults that can be cleared in remote mode.

With the Logic Input Terminals

Use the logic input terminals F, R, RES, or VIA to clear a drive detected fault if parameter [\[Command mode sel\]](#) (*C P o d*) is set to 0 (factory setting).

With the graphic/embedded display terminals

The STOP key can be used to clear a drive detected fault if parameter [\[Command mode sel\]](#) (*C P o d*) is set to 1.

To clear a drive detected fault, press the STOP key. If it is possible to reset the drive, it will display *C L r*. To clear the detected fault, press the STOP key a second time.

If the cause of the interruption is still present, the *C L r* display will not appear. Diagnose and clear the detected fault before attempting to reset the drive.

The use of the STOP key as a clear detected fault can be managed by parameter [\[HMI reset button\]](#) (*F 7 3 5*).

With Serial Communication

A drive detected fault can be cleared over the serial communication link (Modbus, Metasys N2, Apogee FLN, BACnet or LonWorks) if parameter [Command mode sel] ($C P O d$) is set to 2.

In the event of an $O L 1$ or $O L 2$ detected fault, the following time periods needs to pass before a clear detected fault is possible:

- $O L 1$ (drive overload) - about 30 seconds after the occurrence of the event.
- $O L 2$ (motor overload) - about 120 seconds after the occurrence of the event.

By Cycling Line Power

A drive detected fault can also be cleared by removing and restoring line power. Be certain that the cause of the detected fault is no longer present and leave power removed long enough for all of the LEDs on the face of the drive to go out.

Cycling power to clear a detected fault can cause the detected fault history to be lost. Refer to parameter $F 6 0 2$ on page [138](#) for drive fault memory options.

Programming



What's in this Part?

This part contains the following chapters:

Chapter	Chapter Name	Page
3	Quick Menu	59
4	Programming Parameters	65
5	Motor Control Parameters	69
6	Drive Control Parameters	87
7	Application Parameters	91
8	I/O Control Parameters	99
9	Display Parameters	129
10	Detected Fault Management Parameters	133
11	Serial Communication Parameters	147
12	Start/Stop Control By Speed Reference Level	153
13	Droop Control	155

Quick Menu

3

What's in this Chapter?

This chapter contains the following topics:

Topic	Page
Quick menu	60

Quick menu

The **AUF** submenu provides ready access to the ten basic parameters commonly used in programming the drive.

In many cases, programming the ATV212 drive is complete when these 10 parameters and motor parameters have been properly set. .

Code	Name / Description	Adjustment range	Factory setting
AU1	[Auto ramp] Automatic ramp adaptation	-	1
0	[Disabled]		
1	[Enable]: [Acceleration time 1] (ACC) and [Deceleration time 1] (dEC)		
2	[ACC only]: [Acceleration time 1] (ACC) only		
	<p>If parameter AU1 is set to 1 or 2, the drive will monitor its own loading level and optimize the acceleration and deceleration ramps. The acceleration and deceleration AU1 = 1 only rates will be automatically adjusted between 1/8 to 8 times the settings of ACC and dEC, depending on the drive's current rating and the load level on the motor. ACC and dEC should be appropriately set for an average load in the application. If the load on the motor increases rapidly during ramp up or ramp down, the auto ramp adaptation feature may not help to prevent the drive from experiencing an overcurrent or overvoltage.</p> <p>If the application requires a consistent acceleration and deceleration time, set AU1 to 0, and set ACC and dEC manually as needed. The manual acceleration and deceleration times can still be overridden by the [Motor Current Limit] (F601) (see page 73) and [Overvoltage fault] (F305) (see page 139) and [Overvoltage level] (F626) (see page 139) functions.</p>		
ACC	[Acceleration time 1]	0.0 to 3200 s	According to drive rating (1)
	<p>The setting of parameter ACC determines the slope of the acceleration ramp and the time it takes for the output frequency of the drive to increase from 0 Hz to the setting of [Max frequency] (FH) (see page 92).</p> <p>If parameter [Auto ramp] (AU1) is set to 1 or 2, the acceleration ramp may be increased or decreased from the setting of ACC, depending on the amount of load on the motor during ramp up.</p> <p>If two different acceleration rates are needed, see parameter [Acceleration time 2] (F500) on page 93.</p>		
dEC	[Deceleration time 1]	0.0 to 3200 s	According to drive rating (1)
	<p>The setting of parameter dEC determines the slope of the deceleration ramp and the time it takes for the output frequency of the drive to decrease from the setting of [Max frequency] (FH) to 0 Hz.</p> <p>If parameter [Auto ramp] (AU1) is set to 1 or 2, the deceleration ramp may be increased or decreased from the setting of dEC, depending on the amount of load on the motor during ramp down. See diagram above.</p> <p>If two different deceleration rates are needed, see parameter [Deceleration time 2] (F501) on page 93.</p>		
LL	[Low limit frequency]	0.0 to [Upper limit freq] (UL) Hz	0.0 Hz
	<p>If [Driving Scroll] (F324) page 160 is set to [yes] (1) the setting is replaced by 30%.</p> <p>Parameter LL sets the minimum frequency that can be commanded to the drive by the local or remote speed reference source.</p>		
UL	[Upper limit freq]	0.5 to [Max frequency] (FH) Hz	50.0 Hz
	<p>If [Driving Scroll] (F324) page 160 is set to [yes] (1) the setting is replaced by 90%.</p> <p>Parameter UL sets the maximum frequency that can be commanded to the drive by the local or remote speed reference source. The top end of its range is limited by the setting of [Max frequency] (FH).</p>		

(1) See table page 199

Code	Name / Description	Adjustment range	Factory setting
tHr	[Motor thermal prot.] Motor Rated Current Overload Setting	10 to 100% of the drive's output current rating	100%
	<p>Set parameter tHr to the motor's rated current as indicated on the motor nameplate for the selected operating voltage. If parameter [Unit value selection] (F701) is set to 1 (see page 130), parameter tHr will be adjusted in amperes. If parameter F701 is set to 0, parameter tHr will be adjusted in percentage. In this case, divide the motor rated current by the drive rated current (as listed on its nameplate) and set parameter tHr to the resulting percentage. The setting of parameter [Switch. freq. level] (F300) does not change the drive's rated current for the sake of this calculation (see page 95).</p>		
FM	[AO scaling] Analog output scaling		-
	<p>Parameter FM is used to match the FM terminal output signal with the input requirements of the attached panel meter by adjusting the slope and bias of the analog output signal. Before adjusting FM, set FMSL to either 15 or 17. As you adjust the value of FM, monitor the display on the attached panel meter. When the meter display reaches 100%, press the ENT key on the drive display terminal. The drive will flash between FM and the adjusted value, indicating that the adjustment has been saved.</p>		
Pt	[Mot cont. mode sel.] Motor control mode		1
	<p>If [Driving Scroll] (F324) page 160 is set to [yes] (1) the setting is replaced by [SVC] (3).</p>		
0	<p>[Constant V/Hz]: Constant V/Hz Use constant V/Hz mode for loads that require the same torque at low speeds as at rated speeds. Low speed torque can be adjusted manually by setting parameter [Motor Voltage Boost] (ub) (see page 73).</p>		
1	<p>[Variable Torque]: Variable torque Use variable torque mode for loads such as centrifugal fans and pumps whose torque requirements increase as a square of the increase in motor speed. Low speed torque can be adjusted manually by setting parameter ub.</p>		
2	<p>[Cst V/Hz+Boost]: Constant V/Hz with automatic torque boost See the diagram on page 70. This mode is similar to the constant V/Hz mode (for loads that require the same torque at low speeds as at rated speeds), except it automatically increases motor voltage and torque to compensate for increases in load.</p>		
3	<p>[SVC]: Sensorless vector control Use sensorless vector control mode to increase torque at motor speeds below 3 Hz or to improve speed regulation (0.5 to 1%). See diagram on page 70.</p>		
4	<p>[Economy]: Energy saving In energy savings mode, the ATV212 drive monitors motor loading and automatically modulates the voltage applied to the motor to optimize energy consumption. If the ATV212 drive and the connected motor have the same power rating, and if the motor has a nominal 1500 rpm rating, no motor auto-tuning is required to use this motor control mode. Otherwise, follow the steps outlined in "Motor Tuning" on page 74.</p>		
5	<p>[Do not use]: Reserved</p>		
6	<p>[PM Control]: Permanent magnet</p>		

Code	Name / Description	Adjustment range	Factory setting
uL	[Motor rated freq.] Motor rated frequency Set parameter uL (vL) to the motor's rated frequency as indicated on the motor nameplate. Note: It is possible to set the drive's various motor control frequencies to 50 Hz by setting [Parameter reset] (tYP) to 1, the 50 Hz reset. For more information, see page 66 .	25.0 to 400.0 Hz	50.0 Hz
uLu	[Motor rated voltage] Set parameter uLu (vLv) to the motor's rated voltage as indicated on the motor nameplate. ATV212●●●M3X: 50 to 330 V. ATV212●●●N4: 50 to 660 V Note: Drive output voltage cannot be set to exceed the input line voltage level.	According to drive rating	According to drive rating (1)

(1) See table page [199](#)

Motor parameters

Configure the motor parameters and perform an auto-tuning ([Auto-tuning drive] (F400) = 2, see page 75 for auto-tuning).

Code	Name / Description	Adjustment range	Factory setting
F415	[Motor rated current] Motor rated full load current Set parameter F415 to the motor rated full load current in amperes as indicated on the motor's nameplate.	0.1 to 200.0 A	According to drive rating (1)
F417	[Motor rated speed] Set parameter F417 to the motor rated speed in rpm as indicated on the motor's nameplate.	100 to 15000 rpm	According to drive rating (1)
F601	[Motor Current Limit] <div style="border: 1px solid black; padding: 10px; text-align: center;"> <p>NOTICE</p> <p>RISK OF DAMAGE TO THE MOTOR AND THE DRIVE</p> <ul style="list-style-type: none"> • Check that the motor will withstand this current. • Check that the profile mission complies with the derating curve given in the installation manual <p>Failure to follow this instruction can result in equipment damage.</p> </div> Parameter F601 can be adjusted to limit current during motoring or braking. Display in Current Limit Mode: When the drive goes into current limit mode, it will: Adjust the output frequency to limit the flow of motor current (down when motoring, up when braking). Display the letter C and the output frequency flashing on the embedded software terminal, ex: C 50 If parameter [Unit value selection] (F701) is set to 1 (see page 130), parameter F601 will be adjusted in amperes. If parameter F701 is set to 0, parameter F601 will be adjusted as a percentage of the drive's output rated current as listed on its nameplate. The setting of parameter [Switch. freq. level] (F300) (see page 95) does not change the drive's rated current for the sake of this calculation. Do not set parameter F601 below the no-load current rating of the motor.	10 to 110% of the drive's output current rating	110%

(1) See table page 200.

Code	Name / Description	Adjustment range	Factory setting
F400	[Auto-tuning drive] Auto tuning enable	-	0
⚡ ⚠ DANGER			
HAZARD OF ELECTRIC SHOCK OR ARC FLASH			
<ul style="list-style-type: none"> • During auto-tuning, the motor operates at rated current. • Do not service the motor during auto-tuning. <p>Failure to follow these instructions will result in death or serious injury.</p>			
⚠ WARNING			
LOSS OF CONTROL			
<ul style="list-style-type: none"> • It is essential that the following parameters uLu, uL, F415 and F417 are correctly configured before starting auto-tuning. • When one or more of these parameters have been changed after auto-tuning has been performed, F400 will return 0 and the procedure will have to be repeated. <p>Failure to follow these instructions can result in death or serious injury.</p>			
NOTICE			
RISK OF DAMAGE TO THE MOTOR			
<ul style="list-style-type: none"> • Conduct auto-tuning only after the motor has been connected and operation completely stopped. • If auto-tuning is conducted immediately after operation stops, the presence of a residual voltage may result in abnormal tuning. <p>Failure to follow these instructions can result in equipment damage.</p>			
0	[Disabled]: Disabled		
1	[Initialize constant]: Factory setting of [Auto Torque Boost] (F402) for asynchronous motor. Factory setting of [Auto Torque Boost] (F402) , [Autotune L q-axis] (F912) , and [Autotune L d-axis] (F913) , and [Motor Rated Voltage] (vlv) for synchronous motor.		
2	[Tun Dyn. 1]: Tune Dynamic, with driving run after the tuning. Application settings of [Auto Torque Boost] (F402) for asynchronous motor. Application settings of [Auto Torque Boost] (F402) , [Autotune L q-axis] (F912) , and [Autotune L d-axis] (F913) for synchronous motor.		
3	[Tun Dyn. 2]: Complete tune Dynamic, with driving run after the tuning. Application settings of [Auto Torque Boost] (F402) , [Autotune L q-axis] (F912) , [Autotune L d-axis] (F913) , and [Motor Rated Voltage] (vlv) for synchronous motor.		
4	[Tun Static 1]: Tune Static, without driving run after the tuning. Application settings of [Auto Torque Boost] (F402) for asynchronous motor. Application settings of [Auto Torque Boost] (F402) , [Autotune L q-axis] (F912) , and [Autotune L d-axis] (F913) for synchronous motor.		
5	[Tun Static 2]: Complete tune Static, without driving run after the tuning. Application settings of [Auto Torque Boost] (F402) , [Autotune L q-axis] (F912) , and [Autotune L d-axis] (F913) , and [Motor Rated Voltage] (vlv) for synchronous motor.		
	Parameter F400 is reset to "0" after the auto tuning is performed.		

Programming Parameters



What's in this Chapter?

This chapter contains the following topics:

Topic	Page
Parameter Reset	66
Macro Programming (AU4)	67
Parameter Lock	68
Display of Submenu AUF (F738)	68

Parameter Reset

Parameter Reset Options

The ATV212 drive offers three options to return parameters to their factory default settings:

- Factory reset: set parameter [Parameter reset] (*EtYP*) to 3
- 50 Hz reset: set parameter [Parameter reset] (*EtYP*) to 1
- 60 Hz reset: set parameter [Parameter reset] (*EtYP*) to 2

Code	Name / Description	Factory setting
<p><i>EtYP</i></p> <p>0</p> <p>1</p> <p>2</p> <p>3</p> <p>4</p> <p>5</p> <p>6</p> <p>7</p> <p>8</p> <p>9</p>	<p>[Parameter reset]</p> <div style="background-color: black; color: white; text-align: center; padding: 5px; font-weight: bold; font-size: 1.2em;"> ⚠ DANGER </div> <p>UNINTENDED EQUIPMENT OPERATION When <i>EtYP</i> is set to 3 or 8:</p> <ul style="list-style-type: none"> - Check that the modification of the current configuration is compatible with the wiring diagram used. - All logic inputs must be deactivated to avoid unintended restart. <p>Failure to follow these instructions will result in death or serious injury.</p> <p>[No action]</p> <p>[50 Hz reset]: 50 Hz parameter reset Setting parameter <i>EtYP</i> to a value of 1 will set specific parameters to values suitable for many 50 Hz (motor base frequency) applications. See Parameters whose values after a reset vary by reset type table on page 198 and table on page 200 for a list of parameters that are affected by this reset action and their resultant values.</p> <p>[60 Hz reset]: 60 Hz parameter reset Setting parameter <i>EtYP</i> to 2 sets specific parameters to values suitable for many 60 Hz (motor base frequency) applications. See table "Parameters whose values after a reset vary by reset type" on page 198 and table "Parameters whose values after a reset are drive model dependant but do not vary by reset type" on page 199 for a list of parameters that are affected by this reset action and their resultant values.</p> <p>[Factory set]: Factory reset Setting parameter <i>EtYP</i> to 3 resets most parameters to their factory settings. See tables listed below for a listing of the values that will be copied into the drive by this factory reset action: Parameters whose values after a reset do not vary by reset type (on page 194). Parameters whose values after a reset vary by reset type (on page 198). Parameters whose values after a reset are drive model dependant but do not vary reset type (on page 199). Parameters whose values after a reset are drive model and reset type dependant (on page 200). Parameters whose values do not change if a reset is performed (on page 201).</p> <p>A factory reset will also clear the detected fault history.</p> <p>[Trip cleared]: detected fault history cleared Setting parameter <i>EtYP</i> to 4 clears the detected fault history. As soon as the detected fault history is reset, parameter <i>EtYP</i> resumes its default value of 0.</p> <p>[Cumul time clear]: Elapsed Motor Run Time Reset Setting parameter <i>EtYP</i> to 5 resets the elapsed motor run time clock. As soon as the elapsed motor run time clock is reset, parameter <i>EtYP</i> resumes its default value of 0.</p> <p>[EtYP fault reset]: Clear <i>EtYP</i> detected fault Setting parameter <i>EtYP</i> to 6 clears a <i>EtYP</i> detected fault. As soon as the <i>EtYP</i> detected fault is cleared, parameter <i>EtYP</i> resumes its default value of 0.</p> <p>[Save parameters]: Save user-defined settings The drive parameter settings can be stored into memory into the drive as a custom parameter set. Set parameter <i>EtYP</i> to 7 to save the current drive parameter settings to memory</p> <p>[Recall parameters]: Recalls user-defined settings The drive parameter settings can be reloaded into the drive as a custom parameter set. Set parameter <i>EtYP</i> to 8 to reload into the drive the parameter settings last saved by setting <i>EtYP</i> to 7.</p> <p>[Elapse time reset]: Elapsed drive run time reset Setting parameter <i>EtYP</i> to 9 resets the elapsed drive run time clock. As soon as the elapsed motor run time clock is reset, parameter <i>EtYP</i> resumes its default value of 0.</p>	<p>0</p>

Macro Programming (AU4)

The ATV212 drive can be configured for four common control schemes by setting parameter AU4:

Code	Name / Description	Factory setting
AU4	[Auto set function] Macro Programming (1)	0
<div style="background-color: black; color: white; padding: 5px; font-weight: bold; font-size: 1.2em;"> ⚠ DANGER </div> <div style="border: 1px solid black; padding: 5px; margin-top: 5px;"> UNINTENDED EQUIPMENT OPERATION Check that the selected macro configuration is compatible with the wiring diagram used. Failure to follow these instructions will result in death or serious injury. </div>		
0	[Factory set] Command reference: logic inputs (CMOd = 0). See page 87. Speed reference: analog input VIA = 0–10 V or 0–20 mA (FMOd = 1, F201 = 0). See [Frequency mode sel] (F P o d) page 87 and Analog Input Speed Reference page 116. F: run forward (F111 = 2). See F Logic Input Function page 100. R: preset speed 1 (F112 = 6). See R Logic Input Function page 100. RES: clear detected fault (F113 = 10). See RES Logic Input Function page 100. Drive ready for operation (F110 = 1). See Active Logic Function 2 page 122.	
1	[Run permissive] Command reference: logic inputs (CMOd = 0). See page 87. Speed reference: analog input VIA = 0–10 V or 0–20 mA (FMOd = 1). See [Frequency mode sel] (F P o d) page 87. F: run forward (F111 = 2). See F Logic Input Function page 100. R: run permissive (F112 = 1). See R Logic Input Function page 100. RES: clear detected fault (F113 = 10). See RES Logic Input Function page 100.	
2	[3-wire] Command reference: logic inputs (CMOd = 0). See page 87. Speed reference: analog input VIA = 0–10 V or 0–20 mA (FMOd = 1). See [Frequency mode sel] (F P o d) page 87. F: run forward (F111 = 2). See F Logic Input Function page 100. R: stop ramp (F112 = 49). See R Logic Input Function page 100. RES: clear detected fault (F113 = 10). See RES Logic Input Function page 100.	
3	[+/- Speed] Command reference: logic inputs (CMOd = 0). See page 87. Speed reference: +/- Speed (FMOd = 5). See [Frequency mode sel] (F P o d) page 87. F: run forward (F111 = 2). See F Logic Input Function page 100. R: + Speed (F112 = 41). See R Logic Input Function page 100. RES: - Speed (F113 = 42). See RES Logic Input Function page 100.	
4	[4-20 mA speed ref] Command reference: logic inputs (CMOd = 0). See page 87. Speed reference: analog input VIA = 4–20 mA (FMOd = 1, F201 = 20). See [Frequency mode sel] (F P o d) page 87 and Analog Input Speed Reference page 116. F: run forward (F111 = 2). See F Logic Input Function page 100. R: preset speed 1 (F112 = 6). See R Logic Input Function page 100. RES: clear detected fault (F113 = 10). See RES Logic Input Function page 100.	

(1) When programming parameter AU4, the embedded display terminal will display two numbers. The left number is the value last entered into AU4. The right number will be 0. Use the UP/DOWN keys to change the right number to the desired value and press ENT. Entering 0 into AU4 has no effect on the drive. Programming 0 into AU4 will not return the seven parameters to their factory default values.

Parameter Lock

Code	Name / Description	Factory setting
F 700	[Parameter lock]	0
0	[Unlocked]: All parameters are unlocked and can be changed. See table on page 41 for the parameters that cannot be changed while the drive is running.	
1	[Locked]: Only parameter F 700 can be changed.	

Display of Submenu AUF (F738)

Code	Name / Description	Factory setting
F 738	[Quick menu AUF]	0
	The setting of this parameter determines whether the AUF submenu, Quick Menu, will be displayed on the HMI (see page 34).	
0	[AUF displayed]: AUF parameter displayed	
1	[AUF hidden]: AUF parameter hidden	

Motor Control Parameters

5

What's in this Chapter?

This chapter contains the following topics:

Topic	Page
Motor Control Mode	70
Other Motor Control Mode Parameters	72
Motor Tuning	74
Auto-tuning	75
Expert parameters	77
Supply Voltage Correction and Motor Voltage Limitation	78
Motor 2 Control Parameters	79
Permanent Magnet Motor Control Law ([PM Control] (P Π))	81

Motor Control Mode

Constant V/Hz Mode with Automatic Torque Boost ([Mot cont. mode sel.] (P L) = 2 [Cst V/Hz+Boost])

Use parameter [Auto Torque Boost] (F 4 0 2) to adjust the amount of automatic torque boost (see page 79).

If the ATV212 drive and the connected motor have the same power rating, and if the motor has a nominal 1500 rpm rating, no motor auto-tuning is required to use this motor control mode. Otherwise, follow the steps outlined in “Motor Tuning” on page 74.

Due to the feedback circuit used in this mode, it is possible for motor speed to oscillate. If this occurs, select the Constant V/Hz mode ([Mot cont. mode sel.] (P L) = 0) and adjust torque boost manually with parameter [Motor Voltage Boost] (u b).

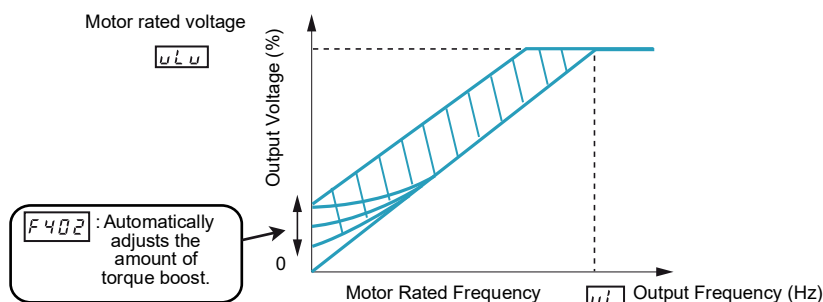

Sensorless Vector Control Mode ([Mot cont. mode sel.] (P L) = 3 [SVC])

Sensorless vector control mode is only for use in applications where:

- Each motor is powered by its own ATV212 drive (not for multi-motor applications).
- The motor has a power rating equal to that of the ATV212 drive, or no lower than one hp rating less.
- The motor has between two and eight poles (750...3000 rpm).

Sensorless vector control will not improve motor control above the motor's rated speed.

Sensorless vector control is more effective if the motor leads are less than 30 m (100 ft) in length. If motor leads longer than 30 m (100 ft) are required, perform an auto-tuning with the long motor leads included in the circuit. Motor torque may not be maximized at the motor's rated frequency due to voltage drop in the motor leads.

Connecting a load reactor or a motor filter on the output of the ATV212 drive may reduce the torque generated by the motor in sensorless vector control mode. Auto-tuning will most likely not be possible with a reactor or filter attached to the drive. Manual tuning will be required.

Permanent Magnet motors Mode ([Mot cont. mode sel.] (P L) = 6 [PM control])

Permanent magnet motors that are light, small in size, and highly efficient, as compared to induction motors, can be operated in sensor-less operation mode.

This feature can be used only for specific permanent magnet motors:

- **IPM**, Interior-buried Permanent Magnet motor.
- **SPM**, Surface-mounted Permanent Magnet motor.

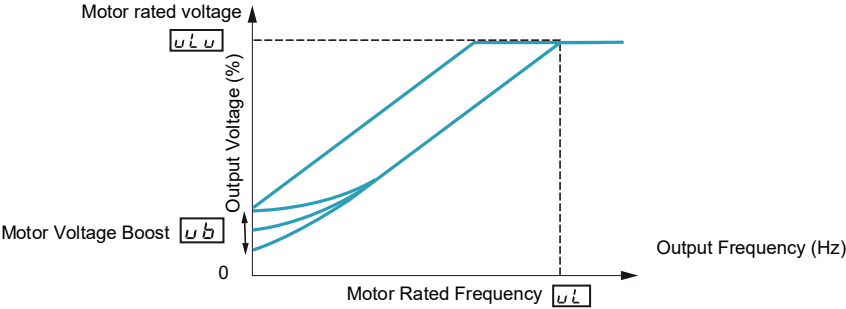
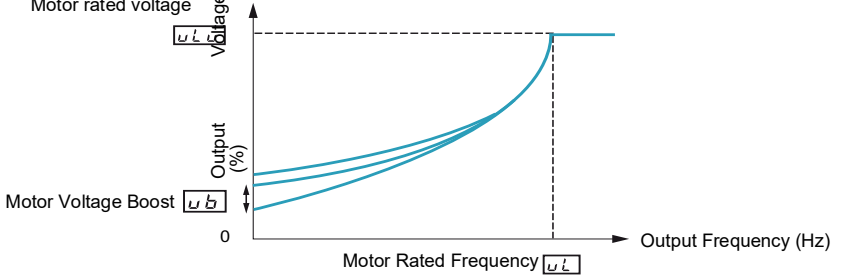
Code	Name / Description	Factory setting
Pt	[Mot cont. mode sel.] Motor control mode	1
	If [Driving Scroll] (F324) page 160 is set to [yes] (1) the setting is replaced by [SVC] (3).	
0	[Constant V/Hz]: Constant V/Hz	
	Use constant V/Hz mode for loads that require the same torque at low speeds as at rated speeds. Low speed torque can be adjusted manually by setting parameter [Motor Voltage Boost] (ub) (see page 73).	
		
1	[Variable Torque]: Variable torque	
	Use variable torque mode for loads such as centrifugal fans and pumps whose torque requirements increase as a square of the increase in motor speed. Low speed torque can be adjusted manually by setting parameter ub .	
		
2	[Cst V/Hz+Boost]: Constant V/Hz with automatic torque boost	
	See the diagram on page 70.	
	This mode is similar to the constant V/Hz mode (for loads that require the same torque at low speeds as at rated speeds), except it automatically increases motor voltage and torque to compensate for increases in load.	
3	[SVC]: Sensorless vector control	
	See the diagram on page 70.	
	Use sensorless vector control mode to increase torque at motor speeds below 3 Hz or to improve speed regulation (0.5 to 1%).	
4	[Economy]: Energy saving	
	In energy savings mode, the ATV212 drive monitors motor loading and automatically modulates the voltage applied to the motor to optimize energy consumption.	
	If the ATV212 drive and the connected motor have the same power rating, and if the motor has a nominal 1500 rpm rating, no motor auto-tuning is required to use this motor control mode. Otherwise, follow the steps outlined in "Motor Tuning" on page 74.	
5	[Do not use]: Reserved	
6	[PM Control]: Permanent Magnet Motor Control Law	
	<div style="background-color: black; color: white; text-align: center; padding: 5px;"> ⚠ ⚠ DANGER </div> <p>HAZARD OF ELECTRIC SHOCK, EXPLOSION OR ARC FLASH</p> <p>If [Mot cont. mode sel.] (Pt) is set to (6) (Permanent Magnet Motor Control Law), output phase loss monitoring, while the motor is running, is disabled. Phase loss and, by implication, accidental disconnection of cables, are not detected.</p> <ul style="list-style-type: none"> Verify that this behavior does not result in unsafe conditions and implement alternative monitoring function if required. <p>Failure to follow these instructions will result in death or serious injury.</p>	

Other Motor Control Mode Parameters

The table below lists other parameters that may need to be adjusted, depending on the setting of parameter [Mot cont. mode sel.] (PE).

Relationship between [Mot cont. mode sel.] (PE) setting and Other Motor Parameters

Parameter	Function	Parameter [Mot cont. mode sel.] (PE) setting					
		0	1	2	3	4	6
		Constant V/Hz Control	Variable Torque Control	Constant V/Hz with Automatic Torque Boost Control	Sensorless Vector Control	Energy Saving Control	Permanent magnet Control
uL (vL)	[Motor rated freq.]	⊗	⊗	⊗	⊗	⊗	⊗
uL u	[Motor rated voltage]	⊗	⊗	⊗	⊗	⊗	⊗
u b	[Mot Voltage Boost]	⊗	⊗	X	X	X	X
F 170	[Mot 2 rated Freq.]	O	X	X	X	X	X
F 171	[Motor 2 rated Volt]	O	X	X	X	X	X
F 172	[Motor 2 Volt Boost]	O	X	X	X	X	X
F 400	[Auto-tuning drive]	X	X	O	O	O	⊗
F 401	[Slip Compensation]	X	X	X	O	X	X
F 402	[Auto Torque Boost]	X	X	⊗	⊗	⊗	⊗
F 415	[Motor rated current]	O	O	⊗	⊗	⊗	⊗
F 416	[Mot no-load current]	X	X	O	O	O	X
F 417	[Motor rated speed]	O	O	⊗	⊗	⊗	⊗
F 418	[Frequency loop gain]	X	X	O	O	O	O
F 458	[Current loop gain]	X	X	O	O	O	O
F 419	[Freq. loop stability]	X	X	O	O	O	O
F 480	[No load cur. coef]	X	X	O	O	X	X
F 485	[Stall control coef. 1]	O	O	O	O	O	O
F 492	[Stall control coef. 2]	O	O	O	O	O	O
F 494	[Mot. adj coefficient]	O	O	O	O	O	O
F 495	[Motor voltage coef.]	O	O	O	O	O	O
F 496	[PWM adj. coef.]	O	O	O	O	O	O
F 912	[Autotune L q-axis]	X	X	X	X	X	⊗
F 913	[Autotune L d-axis]	X	X	X	X	X	⊗
F 921	[Init. Pos. Current]	X	X	X	X	X	O
F 914	[N-S direction]	X	X	X	X	X	O
F 915	[PM mode selection]	X	X	X	X	X	⊗
F 916	[PM Align cur. Level]	X	X	X	X	X	O

X: Not applicable for the [Mot cont. mode sel.] (PE) setting

⊗: Adjustment of this parameter is required.

O: Adjust this parameter if necessary.

Code	Name / Description	Adjustment range	Factory setting
u b	<p>[Motor Voltage Boost]</p> <p>Low speed motor torque can be adjusted with parameter u b when parameter [Mot cont. mode sel.] (P E) (see page 71) is set to 0 (Constant V/Hz) or 1 (Variable Torque). See curves on page 70 for more information. If nuisance overcurrent faults occur during starting, reducing the setting of parameter u b may help.</p>	0.0 to 30.0%	According to drive rating (1)
F 6 0 I	<p>[Motor Current Limit]</p> <div style="border: 1px solid black; padding: 10px; text-align: center; margin: 10px 0;"> <p>NOTICE</p> <p>RISK OF DAMAGE TO THE MOTOR AND THE DRIVE</p> <ul style="list-style-type: none"> ● Check that the motor will withstand this current. ● Check that the profile mission complies with the derating curve given in the installation manual <p>Failure to follow this instruction can result in equipment damage.</p> </div> <p>Parameter F 6 0 I can be adjusted to limit current during motoring or braking.</p> <p>Display in Current Limit Mode: When the drive goes into current limit mode, it will: Adjust the output frequency to limit the flow of motor current (down when motoring, up when braking).</p> <p>Display the letter C and the output frequency flashing on the embedded software terminal, ex: C 50</p> <p>If parameter [Unit value selection] (F 7 0 I) is set to 1 (see page 130), parameter F 6 0 I will be adjusted in amperes. If parameter F 7 0 I is set to 0, parameter F 6 0 I will be adjusted as a percentage of the drive's output rated current as listed on its nameplate.</p> <p>The setting of parameter [Switch. freq. level] (F 3 0 0) (see page 95) does not change the drive's rated current for the sake of this calculation.</p> <p>Do not set parameter F 6 0 I below the no-load current rating of the motor.</p>	0.0 to 30.0%	10 to 110% of the drive's output current rating 110%

(1) See table page 199.

Motor Tuning

Tuning the drive to specific motor values will optimize motor performance if parameter [\[Mot cont. mode sel.\] \(PE\)](#) (see page [71](#)) is set to:

- 2 (constant V/Hz with automatic boost),
- 3 (sensorless vector control), or
- 4 (energy savings)

At a minimum, manually set parameters uL (vL), uLu (vLv), $F415$, $F416$, and $F417$.

Parameters [\[Slip Compensation\] \(F401\)](#), [\[Auto Torque Boost\] \(F402\)](#), [\[Frequency loop gain\] \(F418\)](#) and [\[Freq. loop stability\] \(F419\)](#) can be set manually or they can be set automatically using the auto tuning function, parameter [\[Auto-tuning drive\] \(F400\)](#).

More precise motor control adjustments can be made with parameters $F307$, $F480$, $F485$, $F492$, and $F494 - F496$.

Code	Name / Description	Adjustment range	Factory setting
uLu	[Motor Rated Voltage] Set parameter uLu (vLv) to the motor's rated voltage as indicated on the motor nameplate. ATV212●●●M3X: 50...330 V. ATV212●●●N4: 50...660 V Note: Drive output voltage cannot be set to exceed the input line voltage level.	According to drive rating (1)	According to drive rating (1)
uL	[Motor rated freq.] If [Driving Scroll] (F324) page 160 is set to [yes] (1) the setting is replaced by 50.0 Hz. Set parameter uL (vL) to the motor's rated frequency as indicated on the motor nameplate. Note: It is possible to set the drive's various motor control frequencies to 50 Hz by setting [Parameter reset] (EYP) to 1, the 50 Hz reset. For more information, see page 66 .	25.0 to 400.0 Hz	50.0 Hz
EHR	[Motor thermal prot.] Motor rated current overload setting Set parameter EHR to the motor's rated current as indicated on the motor nameplate for the selected operating voltage. If parameter [Unit value selection] (F701) is set to 1 (see page 130), parameter EHR will be adjusted in amperes. If parameter $F701$ is set to 0, parameter [Motor thermal prot.] (EHR) will be adjusted in percentage. In this case, divide the motor rated current by the drive rated current (as listed on its nameplate) and set parameter EHR to the resulting percentage. The setting of parameter [Switch. freq. level] (F300) does not change the drive's rated current for the sake of this calculation (see page 95).	10 to 100% of the drive's output current rating	100%
$F607$	[Mot overload time] Motor overload time <div style="text-align: center;">NOTICE</div> RISK OF DAMAGE TO THE MOTOR Check that the motor will withstand this time without overheating Failure to follow this instruction can result in equipment damage. Parameter $F607$ determines how long the drive will support a 150% motor overload before a fault detection occurs.	10...2400 s	300 s
$F415$	[Motor rated current] Set parameter $F415$ to the motor rated current in amperes as indicated on the motor's nameplate.	0.1 to 200.0 A	According to drive rating (1)
$F416$	[Mot no-load current] Motor no-load current Set parameter $F416$ to the ratio of the motor's no load current to its rated current.	10.0 to 100.0%	According to drive rating (1)
$F417$	[Motor rated speed] Motor rated speed Set parameter $F417$ to the motor rated speed in rpm as indicated on the motor's nameplate.	100.0 to 15000 rpm	According to drive rating (1)

(1) See table page [199](#).

Auto-tuning

Before performing an auto-tune, verify that:

- A motor is connected and any load-side disconnect is closed.
- The motor is completely stopped and de-energized.
- The motor should be cool (room temperature).
- There is only one motor connected to the drive.
- All of the motor leads that will be used in the final installation are included in the output circuit during the auto-tuning process.
- Motor leads are no longer than 30 m (100 ft). Motor leads longer than 30 m (100 ft) may result in reduced motor torque and less than optimal motor control.
- No load reactors or filters are included in the motor circuit. Output reactors and filters may cause an auto-tuning detected fault *E t n I* and reduce effectiveness of sensorless vector control.
- The motor is not more than 1 hp size smaller than the drive.
- The motor has at least 2 and not more than 8 poles (750...3000 rpm).
- The motor does not have a high slip rating.

Auto tuning is performed upon the first start command after parameter [Auto-tuning drive] (*F 4 0 0*) below is set to 1, 2 and 3 and is normally completed within 3 seconds. During the auto-tuning process, the graphic display option displays *R t n I*.

During the auto-tuning process voltage is applied to the motor, although it barely rotates and produces very little torque.

During the auto-tuning process, the drive checks for an output phase loss detection regardless of the setting of parameter *F 6 0 5*. An output phase loss detection *E P H 0* will abort the auto-tuning process.

If the auto-tuning process is unsuccessful, the drive will display *E t n I*. In this event, no results of the aborted auto-tuning 1 will be saved in the drive, and a manual tuning of parameters [Slip Compensation] (*F 4 0 1*), [Auto Torque Boost] (*F 4 0 2*), [Frequency loop gain] (*F 4 1 8*) and [Freq. loop stability] (*F 4 1 9*) will be required.

Code	Name / Description	Adjustment range	Factory setting
F 400	[Auto-tuning drive]	-	0
⚠ ⚠ DANGER			
HAZARD OF ELECTRIC SHOCK OR ARC FLASH			
<ul style="list-style-type: none"> • During auto-tuning, the motor operates at rated current. • Do not service the motor during auto-tuning. <p>Failure to follow these instructions will result in death or serious injury.</p>			
⚠ WARNING			
LOSS OF CONTROL			
<ul style="list-style-type: none"> • It is essential that the following parameters uL u, uL, F 415 and F 417 are correctly configured before starting auto-tuning. • When one or more of these parameters have been changed after auto-tuning has been performed, F 400 will return 0 and the procedure will have to be repeated. <p>Failure to follow these instructions can result in death or serious injury.</p>			
NOTICE			
RISK OF DAMAGE TO THE MOTOR			
<ul style="list-style-type: none"> • Conduct auto-tuning only after the motor has been connected and operation completely stopped. • If auto-tuning is conducted immediately after operation stops, the presence of a residual voltage may result in abnormal tuning. <p>Failure to follow these instructions can result in equipment damage.</p>			
	Auto tuning enable		
0	[Disabled]		
1	[Initialize constant]: Factory setting of [Auto Torque Boost] (F 402) for asynchronous motor. Factory setting of [Auto Torque Boost] (F 402), [Autotune L q-axis] (F 912), and [Autotune L d-axis] (F 913), and [Motor Rated Voltage] (vlv) for synchronous motor.		
2	[Tun Dyn. 1]: Tune Dynamic, with driving run after the tuning. Application settings of [Auto Torque Boost] (F 402) for asynchronous motor. Application settings of [Auto Torque Boost] (F 402), [Autotune L q-axis] (F 912), and [Autotune L d-axis] (F 913) for synchronous motor.		
3	[Tun Dyn. 2]: Complete tune Dynamic, with driving run after the tuning. Application settings of [Auto Torque Boost] (F 402), [Autotune L q-axis] (F 912), [Autotune L d-axis] (F 913), and [Motor Rated Voltage] (vlv) for synchronous motor.		
4	[Tun Static 1]: Tune Static, without driving run after the tuning. Application settings of [Auto Torque Boost] (F 402) for asynchronous motor. Application settings of [Auto Torque Boost] (F 402), [Autotune L q-axis] (F 912), and [Autotune L d-axis] (F 913) for synchronous motor.		
5	[Tun Static 2]: Complete tune Static, without driving run after the tuning. Application settings of [Auto Torque Boost] (F 402), [Autotune L q-axis] (F 912), and [Autotune L d-axis] (F 913), and [Motor Rated Voltage] (vlv) for synchronous motor.		
	Parameter F 400 is reset to "0" after the auto tuning is performed.		

Expert parameters

Code	Name / Description	Adjustment range	Factory setting
F 390	[LL for ov.cur. prev.] Lower Limit function for Over Current Prevention In the present software, motor speed is decreased to 0 Hz in case the stall prevention state is continued. When motor speed is lower than F 390 during stall prevention, motor speed is kept to F 390 to increase motor current. In this situation, motor current is beyond stall prevention level (F 601 or F 185), therefore over current or over load detected fault may occur in some case.	0.0 - μL	0.0
F 480	[No load cur. coef] Magnetizing current coefficient	100 to 130%	100%
	Use parameter F 480 to fine-tune motor torque during low-speed operation. To increase motor torque in the low-speed operating range, increase the setting of parameter F 480 . However, only adjust parameter F 480 if an auto tune does not yield sufficient low-speed torque. Increasing the setting of parameter F 480 may increase the motor's no-load current during low-speed operation. Do not set this parameter so that the motor's no-load current exceeds its rated operating current.		
F 485	[Stall control coef. 1] Stall prevention control coefficient 1	10 to 250	100
	Use parameter F 485 to adjust the drive's response to large, sudden changes in load when the motor is operated above its rated frequency. If a sudden change in load causes the motor to stall before the drive goes into current limit, gradually reduce the setting of F 485 .		
F 492	[Stall control coef. 2] Stall prevention control coefficient 2	50 to 150	100
	Use parameter F 492 to adjust the drive's response to a drop in the line supply voltage when the motor is operated above its rated frequency. Such a drop in voltage often causes fluctuations in motor current or vibration in the motor. To reduce these disturbances, set parameter F 492 to a value from 80 to 90. Note: Reducing the F 492 setting increases the motor running current level.		
F 494	[Mot. adj coefficient] Motor adjustment coefficient	-	-
	DO NOT ADJUST.		
F 495	[Motor voltage coef.] Maximum voltage adjustment coefficient	90 to 120%	104%
	Use parameter F 495 to limit the drive's maximum output voltage. Increasing this setting increases torque when the motor is operated above its rated frequency, but may also cause motor vibration. Do not increase the value of F 495 if motor vibrations occur.		
F 496	[PWM adj. coef.] Waveform switching adjustment coefficient	0.1 to 14.0 kHz	14.0 kHz
	Adjusting the value of parameter F 496 may reduce motor noise and vibration during PWM waveform frequency shifts in the mid-speed operating range.		

Supply Voltage Correction and Motor Voltage Limitation

The setting of parameter **F 3 0 7** determines:

- If the drive's voltage output will be corrected for fluctuations in the line supply voltage, or
- If the drive's voltage output will be limited, despite increases in the line supply voltage.

The drive's output voltage will not exceed the input supply voltage.

If parameter **F 3 0 7** is set to 0 or 2, no corrections are made in the motor voltage gating process in response to fluctuations in supply voltage. As a result, the V/Hz value of the output waveform to the motor will change in proportion to the input voltage. Conversely, if **F 3 0 7** is set to 1 or 3, the V/Hz value of the output waveform will be held constant, despite changes in the supply voltage level.

If parameter **F 3 0 7** is set to 0 or 1, output motor voltage will be limited to the value set by parameter **[Motor rated voltage] (u L u)** (see page 74), even if the input supply voltage rises. If **F 3 0 7** is set to 2 or 3, output motor voltage can rise above the level set by **u L u** if the input supply voltage rises above the motor rated voltage.

If parameter **[Mot cont. mode sel.] (P L)** is set to a value of 2, 3, 4, 5, or 6, the supply voltage is corrected, regardless of the setting of parameter **F 3 0 7**.

The diagrams below illustrate the impact of each setting of parameter **F 3 0 7**.

F307 = 0
Supply Voltage uncorrected, Motor Voltage Limited

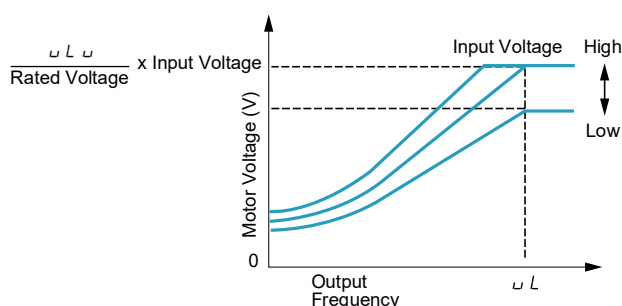

F307 = 1
Supply Voltage corrected, Motor Voltage Limited

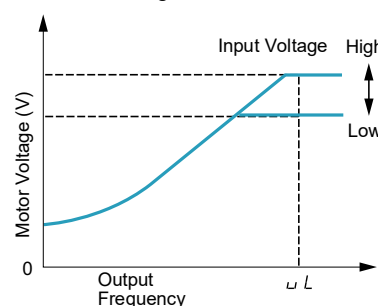

F307 = 2
Supply Voltage uncorrected, Motor Voltage Unlimited

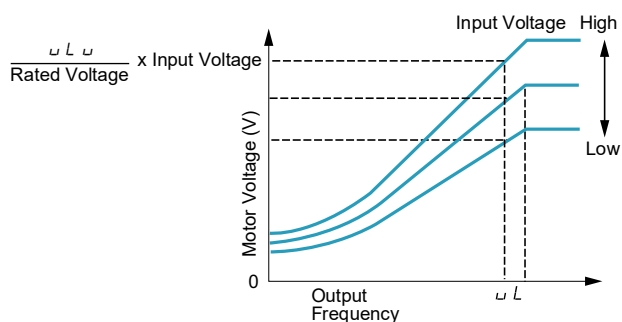

F307 = 3
Supply Voltage corrected, Motor Voltage Unlimited

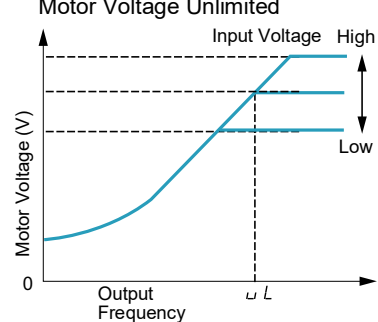

Code	Name / Description	Factory setting
F 3 0 7	[Mot volt limitation] Supply Voltage Correction and Motor Voltage Limitation	3
0	[Motor volt limit]: Supply voltage uncorrected – motor voltage limited	
1	[Line&mot correct.]: Supply voltage corrected – motor voltage limited	
2	[No action]: Supply voltage uncorrected – motor voltage unlimited	
3	[U Line correction]: Supply voltage corrected – motor voltage unlimited	

Motor 2 Control Parameters

When logic inputs assigned to functions 39 or 40 are active, parameters **F 170** to **F 173** and **F 185** are the active set of motor control parameters.

When motor 2 control parameters are active, only constant V/Hz Motor Control Mode ([Mot cont. mode sel.] (P L) = 0) is available (see page 71).

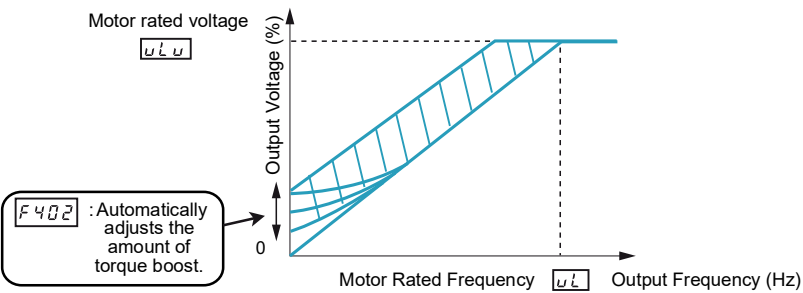
Code	Name / Description	Adjustment range	Factory setting
F 170	[Mot 2 rated Freq.] Motor 2 rated frequency	25.0 to 400.0 Hz	50.0 Hz
	Set parameter F 170 to the motor's rated frequency as indicated on the motor nameplate.		
	Note: It is possible to set the drive's various motor control frequencies to 50 Hz by setting [Parameter reset] (L 9P) to 1, the 50 Hz reset. For more information, see page 66.		
F 171	[Motor 2 rated Volt] Motor 2 rated voltage	According to drive rating (1)	According to drive rating (1)
	Set parameter F 171 to the motor's rated voltage as indicated on the motor nameplate. ATV212●●●M3X: 50...330 V. ATV212●●●N4: 50...660 V		
	Note: Drive output voltage cannot be set to exceed the input line voltage.		
F 172	[Motor 2 Volt Boost] Motor 2 voltage boost	0 to 30%	According to drive rating (1)
F 173	[Motor 2 Overload] Motor 2 rated current overload setting	10 to 100% of the drive's output current rating	100%
	Set parameter F 173 to the motor's rated current as listed on the motor nameplate for the selected operating voltage.		
F 185	[Mot. 2 current limit] Motor 2 current limit	10 to 100% of the drive's output current rating	110%
NOTICE			
RISK OF DAMAGE TO THE MOTOR AND THE DRIVE			
<ul style="list-style-type: none"> • Check that the motor will withstand this current. • Check that the profile mission complies with the derating curve given in the installation manual. Failure to follow this instruction can result in equipment damage.			
Adjust parameter F 185 to limit current during motoring or braking. Do not set parameter F 185 below the no-load current rating of the motor; otherwise, the drive will determine that motor braking is taking place and will increase the frequency applied to the motor.			
F 401	[Slip Compensation]	0 to 150%	50%
	If [Driving Scroll] (F324) page 160 is set to [yes] (1) the setting is replaced by 0%.		
	Before adjusting parameter F 401 , verify that parameter [Motor rated speed] (F 417) (see page 74) is set to the rated speed of the motor in rpm. Parameter F 401 can be used to fine tune the drive's slip compensation feature. Increasing the value of parameter F 401 increases the drive's compensation of motor slip.		
F 402	[Auto Torque Boost]	0.0 to 30.0%	According to drive rating (1)
	Use parameter F 402 to adjust the amount of automatic torque boost that is applied.		
	 <p>The graph plots Output Voltage (%) on the y-axis against Motor Rated Frequency and Output Frequency (Hz) on the x-axis. A dashed horizontal line represents the Motor rated voltage (ULU). A solid line shows the output voltage increasing linearly with frequency until it reaches the Motor rated voltage. A shaded area between the solid line and a lower line indicates the torque boost range. A callout box labeled 'F 402' points to this shaded area with the text: 'F 402 : Automatically adjusts the amount of torque boost.'</p>		

(1) See table page 199.

Code	Name / Description	Adjustment range	Factory setting
F 4 18	[Frequency loop gain] Parameters F 4 18 and [Freq. loop stability] (F 4 19) reduce the speed of the drive's response to a change in speed command. The factory setting of these two parameters assumes that the inertia of the load is three times as large as that of the motor shaft. Adjust these two parameters if the factory setting is not appropriate for the application. Note: It is possible for the drive's output frequency to exceed its upper limit (parameter [Max frequency] (F H)) if the acceleration parameter (A C C or F 5 0 7) is set to its minimum value. Increasing the setting of parameter F 4 18 reduces the drive's response time to changes in the speed reference.	1 to 150	40
F 4 19	[Freq. loop stability] Frequency loop stability Increasing the setting of parameter F 4 19 further reduces the drive's response to changes in the speed reference.	1 to 100	20

Permanent Magnet Motor Control Law ([PM Control] (Pn))

Drive may be set to control synchronous motor. When [PM control] is activated, motor parameters are set to new default value. You can access to additional settings to optimize the motor control.

Motor parameters setting.

These motor parameters below are needed to set:

1 - Set ([PE] [Mot cont. mode sel.] to [PM Control] (E) see page 82.

2 - Set [Motor rated freq.] (uL), see page 74:

Note: $\text{Motor rated freq. (uL)} = \frac{\text{Motor rated speed (F4 I 7)}}{60 / np}$

[Motor rated speed] (F4 I 7), see page 74, indicated on the motor nameplate or follow the procedure step 4 above.

np = Number of pole pairs, indicated on the motor nameplate.

3 - Set the Motor rated power (unit is kW) by [Motor rated cap.] (F405), see page 82

Note: $P = C \times \omega$

P = Power in W

C = N.m, indicated on the motor nameplate.

$\omega = \text{rad s}^{-1}$

$\omega = 2\pi \times (\text{FRS}/np)$

FRS = [Motor rated freq.] (uL) see page 74, indicated on the motor nameplate.

np = Number of pole pairs, indicated on the motor nameplate.

4 - Motor rated current (unit is A) is set by [Motor rated current] (F4 I 5), see page 74.

5 - Set [Motor rated speed] (F4 I 7), see page 74, without information:

Set the motor rated speed by $\text{FRS} \times (60 / np)$

FRS = [Motor rated freq.] (uL) see page 74, indicated on the motor nameplate.

np = Number of pole pairs, indicated on the motor nameplate.

6 - Configure [Auto-tuning drive] (F400) to [Tun Static 2] (5), see page 83. Make the TUN (Run order is needed to start the TUN.)

- Motor's rated voltage is set by [Motor Rated Voltage] (uL u)^a, see page 82.

- Stator resistance is set by [Auto Torque Boost] (F402)^a, see page 84.

- Axis "q" stator inductance in mH is set by [Autotune L q-axis] (F9 I 2)^a, see page 85.

- Axis "d" stator inductance in mH is set by [Autotune L d-axis] (F9 I 3)^a, see page 85.

7 - Check the value of [Saliency Level] (F936), see page 84.

8 - Set [PM mode selection] (F9 I 5) according to the [Saliency Level] (F936) value (see page 84).

9 - If (F936) is ≥ 0.2 , increase [Init. Pos. Current] (F92 I) see page 85.

Configure [Auto-tuning drive] (F400) to [Tun Static 2] (5), see page 83. Make the TUN (Run order is needed to start the TUN.)

10 - Start the motor,

- if there is current limitation on starting, increase the [PM Align cur. Level] (F9 I 6) value (See page 85).

- if its behavior is not optimal, reduce by 20% [Motor Rated Voltage] (uL u) value (see page 82).

- After this procedure, if you need further assistance, contact your Schneider Electric Product Support.

(a) [Auto Torque Boost] (F402), [Autotune L q-axis] (F9 I 2), [Autotune L d-axis] (F9 I 3), and [Motor Rated Voltage] (uL u) may be defined automatically after activation of [Auto-tuning drive] (F400) = [Tun Dyn. 2] (3) or [Tun Static 2] (5)

Code	Name / Description	Adjustment range	Factory setting
Pt	[Mot cont. mode sel.] Motor control mode selection If [Driving Scroll] (F324) page 160 is set to [yes] (1) the setting is replaced by [SVC] (3) 0 [Constant V/Hz]: Constant V/Hz 1 [Variable Torque]: Variable torque 2 [Cst V/Hz+Boost]: Constant V/Hz with automatic torque boost 3 [SVC]: Sensorless vector control 4 [Economy]: Energy saving 5 [Do not use]: Reserved 6 [PM Control]: Permanent Magnet Motor Control Law	-	1
	⚡ ⚠ DANGER		
	HAZARD OF ELECTRIC SHOCK, EXPLOSION OR ARC FLASH If [Mot cont. mode sel.] (Pt) is set to (6) (Permanent Magnet Motor Control Law), output phase loss monitoring, while the motor is running, is disabled. Phase loss and, by implication, accidental disconnection of cables, are not detected. Verify that this behavior does not result in unsafe conditions and implement alternative monitoring function if required. Failure to follow these instructions will result in death or serious injury.		
uLu	[Motor Rated Voltage] Set parameter uLu (vLv) to the motor's rated voltage as indicated on the motor nameplate. ATV212●●●M3X: 50...330 V ATV212●●●N4: 50...660 V Note: Drive output voltage cannot be set to exceed the input line voltage level. uLu (vLv) may be defined automatically after activation of F400 = [Tun Dyn. 2] (3) or [Tun Static. 2] (5) if [Mot cont. mode sel.] (Pt) = (6)	According to drive rating (1)	According to drive rating (1)
uL	[Motor rated freq.] Set parameter uL (vL) to the motor's rated frequency as indicated on the motor nameplate. Note: It is possible to set the drive's various motor control frequencies to 50 Hz by setting [Parameter reset] (L4P) to 1, the 50 Hz reset. For more information, see page 66.	25.0 to 400 Hz	50.0 Hz
F405	[Motor rated cap.] Motor rated capacity Set parameter F405 to the motor rated capacity in kilowatt. It permits to calculate automatically [Motor Rated Voltage] (uLu) after TUN F400 [Auto-tuning drive]	0.01 to 75 kW	According to drive rating (1)
F415	[Motor rated current] Set parameter F415 to the motor rated current in amperes as indicated on the motor's nameplate.	0.1 to 200.0 A	According to drive rating (1)
F417	[Motor rated speed] Motor rated speed Set parameter F417 to the motor rated speed in rpm as indicated on the motor's nameplate.	100.0 to 15000 rpm	According to drive rating (1)

(1) See table page 199.

F 4 0 0	[Auto-tuning drive]	-	0
<div style="background-color: black; color: white; padding: 5px; text-align: center;"> DANGER </div> <p>HAZARD OF ELECTRIC SHOCK OR ARC FLASH</p> <ul style="list-style-type: none"> ● During auto-tuning, the motor operates at rated current. ● Do not service the motor during auto-tuning. <p>Failure to follow these instructions will result in death or serious injury.</p>			
<div style="background-color: black; color: white; padding: 5px; text-align: center;"> WARNING </div> <p>LOSS OF CONTROL</p> <ul style="list-style-type: none"> ● It is essential that the following parameters uL u, uL, F 4 1 5 and F 4 1 7 are correctly configured before starting auto-tuning. ● When one or more of these parameters have been changed after auto-tuning has been performed, F 4 0 0 will return 0 and the procedure will have to be repeated. <p>Failure to follow these instructions can result in death or serious injury.</p>			
<div style="background-color: black; color: white; padding: 5px; text-align: center;"> NOTICE </div> <p>RISK OF DAMAGE TO THE MOTOR</p> <ul style="list-style-type: none"> ● Conduct auto-tuning only after the motor has been connected and operation completely stopped. ● If auto-tuning is conducted immediately after operation stops, the presence of a residual voltage may result in abnormal tuning. <p>Failure to follow these instructions can result in equipment damage.</p>			
<p>Auto tuning enable</p> <p>0 [Disabled]</p> <p>1 [Initialize constant]: Factory setting of [Auto Torque Boost] (F 4 0 2) for asynchronous motor. Factory setting of [Auto Torque Boost] (F 4 0 2), [Autotune L q-axis] (F 9 1 2), and [Autotune L d-axis] (F 9 1 3), and [Motor Rated Voltage] (vlv) for synchronous motor.</p> <p>2 [Tun Dyn. 1]: Tune Dynamic, with driving run after the tuning. Application settings of [Auto Torque Boost] (F 4 0 2) for asynchronous motor. Application settings of [Auto Torque Boost] (F 4 0 2), [Autotune L q-axis] (F 9 1 2), and [Autotune L d-axis] (F 9 1 3) for synchronous motor.</p> <p>3 [Tun Dyn. 2]: Complete tune Dynamic, with driving run after the tuning. Application settings of [Auto Torque Boost] (F 4 0 2), [Autotune L q-axis] (F 9 1 2), [Autotune L d-axis] (F 9 1 3), and [Motor Rated Voltage] (vlv) for synchronous motor.</p> <p>4 [Tun Static 1]: Tune Static, without driving run after the tuning. Application settings of [Auto Torque Boost] (F 4 0 2) for asynchronous motor. Application settings of [Auto Torque Boost] (F 4 0 2), [Autotune L q-axis] (F 9 1 2), and [Autotune L d-axis] (F 9 1 3) for synchronous motor.</p> <p>5 [Tun Static 2]: Complete tune Static, without driving run after the tuning. Application settings of [Auto Torque Boost] (F 4 0 2), [Autotune L q-axis] (F 9 1 2), and [Autotune L d-axis] (F 9 1 3), and [Motor Rated Voltage] (vlv) for synchronous motor.</p> <p>Parameter F 4 0 0 is reset to "0" after the auto tuning is performed.</p>			
F 4 5 8	[Current loop gain]	Current loop gain	0 Hz
<p>Parameter F 4 5 8 is set to the response gain of current loop. If [Mot cont. mode sel.] (Pt) page 82 is set to [PM control] (6) the setting is replaced by 25 Hz.</p> <p>Note: Contact Schneider electric product support to confirm the modification of this parameter.</p>			

(1) See table page [199](#).

F 4 1 8	[Frequency loop gain]		1 to 150	40
<p>Parameters F 4 1 8 and [Freq. loop stability] (F 4 1 9) reduce the speed of the drive's response to a change in speed command. The factory setting of these two parameters assumes that the inertia of the load is three times as large as that of the motor shaft. Adjust these two parameters if the factory setting is not appropriate for the application.</p> <p>Note: It is possible for the drive's output frequency to exceed its upper limit (parameter [Max frequency] (F H)) if the acceleration parameter (A C C or F 5 0 7) is set to its minimum value.</p> <p>Increasing the setting of parameter F 4 1 8 reduces the drive's response time to changes in the speed reference.</p>				
F 4 1 9	[Freq. loop stability]	Frequency loop stability	1 to 100	20
<p>Increasing the setting of parameter F 4 1 9 further reduces the drive's response to changes in the speed reference.</p>				
F 4 9 5	[Motor voltage coef.]	Maximum voltage adjustment coefficient	90 to 120%	104%
<p>Use parameter F 4 9 5 to limit the drive's maximum output voltage. Increasing this setting increases torque when the motor is operated above its rated frequency, but may also cause motor vibration. Do not increase the value of F 4 9 5 if motor vibrations occur.</p>				
F 9 3 6	[Saliency Level]	Saliency coefficient for PM motor	0 to 2.55	0
<p>PM type [PM mode selection] (F 9 1 5) is selected by the saliency level [Saliency Level] (F 9 3 6)</p> <p>F 9 3 6 ≥ 0.2 = high saliency F 9 3 6 < 0.2 = low saliency.</p> <p>Note: This parameter is automatically computed with the setting of [Autotune L q-axis] (F912) and [Autotune L d-axis] (F913)</p>				
F 9 1 5	[PM mode selection]	PM control mode selection	-	3
0	[Basic Ctrl]: basic control			
1	[Ctrl Type1]: control type 1 (for IPM, interior-buried Permanent Magnet motor)			
2	[Ctrl Type2]: control type 2 (for IPM, interior-buried Permanent Magnet motor)			
3	[Ctrl Type3]: control type 3 (for IPM / SPM, interior-buried Permanent Magnet motor / Surface-mounted Permanent Magnet motor)			
4	[Ctrl Type4]: control type 4 (for IPM / SPM, interior-buried Permanent Magnet motor / Surface-mounted Permanent Magnet motor)			

Refer to the following tables to select the setting of the parameter **F 9 1 5**, **F 9 1 5** is selected by the saliency level **F 9 3 6**

	- big starting torque is needed. - for constant torque application.(1)	- big starting torque is not needed. - for variable torque application (2)	- big starting torque is not needed - for variable torque application - motor electrical magnetic noise is forbidden (3)
The saliency level is high (F 9 3 6 ≥ 0.2)	F915 = 4 or 2	F915 =1 or 3	F915 =0
The saliency level is low (F 9 3 6 < 0.2)	F915 =3		

- (1) There is some motor electrical magnetic noise at start and low speed area.
- (2) There is some motor electrical magnetic noise at start. It can not be started in case of high start-up torque.
- (3) It goes opposite direction at start sometimes. It cannot be started in case rotor saliency is high.

Code	Name / Description	Adjustment range	Factory setting
F 4 0 2	[Auto Torque Boost]	0.0 to 30.0%	According to drive rating
<p>Use parameter F 4 0 2 to adjust the amount of automatic torque boost that is applied.</p> <div style="display: flex; align-items: center;"> <div style="border: 1px solid black; border-radius: 10px; padding: 5px; margin-right: 10px;"> F 4 0 2 : Automatically adjusts the amount of torque boost. </div> </div>			

<p>F 9 1 2</p>	<p>[Autotune L q-axis] q-axis self-inductance</p> <p>Axis "q" stator inductance in mH The setting is replaced by the result of the auto-tuning operation, if it has been performed.</p> <p>Measured between the neutral and the phase, its value could be different than the datasheet of the motor. [Autotune L q-axis] (F 9 1 2) is defined automatically after activation of [Auto-tuning drive] (F 4 0 0) = [Tun Dyn. 2] (3)</p>	<p>0.01 to 650 mH</p>	<p>10</p>
<p>F 9 1 3</p>	<p>[Autotune L d-axis] d-axis self-inductance</p> <p>Axis "d" stator inductance in mH The setting is replaced by the result of the auto-tuning operation, if it has been performed.</p> <p>Measured between the neutral and the phase, its value could be different than the datasheet of the motor. [Autotune L q-axis] (F 9 1 3) is defined automatically after activation of [Auto-tuning drive] (F 4 0 0) = [Tun Dyn. 2] (3)</p>	<p>0.01 to 650 mH</p>	<p>10</p>
<p>F 9 1 6</p>	<p>[PM Align cur. Level] Stabilization at the starting and low speed(for PM)</p> <p>It might be able to stabilize the motor rotation behavior by the current in D axis at no load when starting or low-speed</p> <p>If you have a torque jolt, when starting / stopping or low-speed, it is recommended to increase the setting of 9 1 6. If E - 2 0 [Excess torque boost flt] trip occurs at the start, it is recommended to increase the setting of 9 1 6.</p> <p>In the case of F915=0, 1, 2, 3</p> <p>In the case of F915=4</p> <p>Starting current F916 is set 25% as the default setting, Limit it to the value of about 75% in the maximum with consideration of copper loss and iron loss of the motor. If the loss of motor at no load is made decreased, please decrease the value of F916 confirming the stability when starting.</p>	<p>0 to 100 %</p>	<p>25 %</p>
<p>F 9 2 1</p>	<p>[Init. Pos. Current] Current for initial position estimation</p> <p>In case of position detection 3, the current level can be set by this parameter, during the auto-tuning for d axis / q axis inductance, the maximum current level can be adjusted by this parameter setting.</p>	<p>10 to 150 %</p>	<p>100 %</p>
<p>F 4 2 0</p>	<p>[Torque Boost Coef] Compensation coefficient of torque boost</p> <p>If synchronous or asynchronous motor is used, F 4 2 0 [Torque Boost Coef] is set to 90%. If you have a torque jolt, when starting / stopping or low-speed, increase the value of F 4 2 0</p> <p>Note: If E - 2 0 [Excess torque boost flt] trip occurs at the start, it is recommended to be decreased the setting of F 4 2 0</p>	<p>0 to 200%</p>	<p>90 %</p>

Parameters described in this page can be accessed by the extended menu

Code	Name / Description	Adjustment range	Factory setting
F914 D I	[N-S direction] Method of detection N-S Method of detection. If F914 = 0, the N-S direction of rotor position is judged by the method of DC offset for position detection. If F914 = 1, the N-S direction of rotor position is judged by the method of AC offset for position detection. Note : N-S method of detection is available if [PM mode selection] (F915) is set to [Ctrl Type1] (1) or [Ctrl Type2] (2)	0 - 1	0
F917 D I	[PM Max torq. Ctrl] Max torque control activation (for IPM) [0] : Deactivation [1] : Activation	0 - 1	1
F918	[Cur. phase adjt] It is possible to aim the higher efficiency in the case of IPM (Interior Permanent Magnet), by activation of [PM Max torq. Ctrl] (F917) which makes required current the minimum, the loss of motor and driver may be reduced and the efficiency may be attained higher level.	- 45.0 to 45.0	0
F920	[Position Adjust] In case of heavy load, the estimated position can be adjusted by setting this parameter. Adjustment for position estimation, available if [PM mode selection] (F915) is set to [Ctrl Type2] (2) or [Ctrl Type4] (4) .	0 - 150 %	0 = Auto

Drive Control Parameters

6

Code	Name / Description	Adjustment range	Factory setting
C P o d	[Command mode sel] Remote Mode Start/Stop Control	-	0
	<p>The setting of parameter C P o d determines the source of start, stop, forward, and reverse operation commands when the drive is in remote mode.</p> <p>The drive needs to be stopped to make changes to parameter C P o d.</p> <p>See diagram on page 50 and description page 54 for more information on the source of the drive's operation commands.</p> <p>0 [Logic inputs]: Control terminal logic inputs 1 [HMI]: Graphic display option 2 [Communication]: Serial communication</p>		
F P o d	[Frequency mode sel] Remote Mode Primary Speed Reference Source	-	1
	<p>The setting of parameter F P o d determines the source of the drive's speed reference when the drive is in remote mode.</p> <p>The drive needs to be stopped to make changes to parameter F P o d.</p> <p>See diagram on page 50 and description page 54 for more information on the source of the drive's speed reference.</p> <p>1 [Ref source VIA]: VIA 2 [Ref source VIB]: VIB 3 [HMI reference]: Graphic display option 4 [Serial com ref.]: Serial communication 5 [+/- Speed]: +/- Speed</p>		
F C	[Local speed ref.] Local Mode Speed Reference	LL - uL	0.0 Hz
	<p>The speed reference set by the UP/DOWN keys in local mode will be stored in parameter F C when the ENT key is pressed.</p> <p>The next time the drive is Power ON in local mode, it will accelerate the motor directly to the speed setpoint memorized by F C.</p>		
F r	[Local mot. direction] Local Mode Motor Rotation Direction Command	-	0
	<p>0 [Run FW]: Run forward only. 1 [Run rev.]: Run reverse only. 2 [Run FW+rev]: Run forward with reverse selectable. 3 [Run rev+FW]: Run reverse with forward selectable.</p> <p>If F r is set to 2 or 3: The motor direction can be changed in local mode to forward by pressing the UP key while holding the ENT key and to reverse by pressing the DOWN key while holding the ENT key. The new motor direction will be displayed (forward = F r - F, reverse = F r - r) before the motor direction is reversed.</p> <p>The motor's last operating direction in local mode will be stored before a power removal or loss detection. When power is restored to the drive, the local mode motor rotation direction will be the same as before the power loss detection.</p> <p>If [Switch rem/Local] F 2 9 5 (see page 88) is enabled and control is transferred from remote to local mode, the local mode operation will assume the same motor rotation direction as in remote mode, regardless of the setting of F r.</p>		
F 7 0 7	[Loc. speed ref. step] Local Mode Speed Reference Step Changes	-	0.0 Hz
	<p>0 [Disable]: Disabled (0.00). 1 [Enable]: Enabled (0.01 to Maximum Frequency [Max frequency] (F H) in Hz).</p> <p>If parameter F 7 0 7 is disabled in local mode, the drive's speed reference will change in steps of 0.1 Hz each time the UP or DOWN key is pressed.</p> <p>If parameter F 7 0 7 is enabled in local mode, the drive's speed reference will change in steps equal to the setting of F 7 0 7 each time the UP or DOWN key is pressed.</p> <p>Enabling parameter F 7 0 7 only affects drive operation if parameter [Customized freq val] (F 7 0 2) is set to 0.00. See page 131.</p> <p>If the display flashes "H i" or "L o", it indicates that repeated usage of the UP or DOWN keys has caused to drive's speed reference to reach either the [Low limit frequency] (LL) (see page 92) or the [Upper limit freq] (uL) (see page 92). This may happen if parameter F 7 0 7 is set to a value larger than 0.00 Hz.</p>		

Code	Name / Description	Adjustment range	Factory setting
F 7 2 1	[Loc. mot stop mode] Local Mode Motor Stop Type	-	0
	<p>The setting of parameter F 7 2 1 determines the type of motor stop that will be executed when the embedded display terminal STOP key is pressed.</p> <p>The RUN and STOP keys need to be enabled by setting parameter [Run/stop key] (F 7 3 3) (see page 90) to 0 for the motor to stop when the embedded display terminal STOP key is pressed.</p> <p>0 [Ramp stop]: Ramp stop 1 [Freewheel]: Freewheel stop</p>		
F 2 9 5	[Switch rem/Local] Bumpless transfer from remote to local control	-	1
	<p>If parameter F 2 9 5 is enabled, the speed reference, run and direction commands will be transferred from remote to local mode when the LOC/REM key is pressed. Operation of the drive is not affected by a remote to local control mode transition.</p> <p>If parameter F 2 9 5 is disabled, a remote to local control mode transition will cause the drive to remove power from the motor. A new run command and speed reference will need to be entered in the local mode.</p> <p>Regardless of the setting of parameter F 2 9 5, a local to remote transition will cause the drive to immediately respond to the remote commands present at the moment of the transition.</p> <p>0 [No bumpless]: Bumpless disabled 1 [Bumpless]: Bumpless enabled</p>		
F 2 5 6	[Time limit low spd]	0.0 to 600 s	0.0 s
0 1	<p>[Disable]: (0.0) [Enable]: (0.01 to 600 seconds)</p> <p>If parameter F 2 5 6 is enabled and if the drive operates continuously at [Low limit frequency] (L L) (see page 92) for a time period equal to the setting of F 2 5 6, the drive will ramp the motor to a stop. While the motor is stopped, "L S T P" will flash on the drive embedded display terminal.</p> <p>When the speed reference to the drive exceeds the low speed level L L + F 3 9 1, the drive will accelerate the motor to the new speed reference.</p> <p>If parameter F 2 5 6 is enabled, drive operation at or below the low speed level is also monitored during startup or during reversing of the motor. See diagram below.</p>		
F 2 0 7	[Remote spd ref 2]	-	2
1 2 3 4 5	<p>VIA VIB HMI Communication +/- Speed</p> <p>Parameter [Remote spd ref 2] (F 2 0 7) defines the remote mode secondary speed reference source. The setting of parameter [Auto/man speed ref] (F 2 0 0) (see page 118) determines whether this source is used for the speed reference.</p> <p>If F 2 0 0 is set to 0, a logic input terminal set to function 38 (see page 118) determines if [Remote spd ref 2] (F 2 0 7) identifies the speed reference source.</p> <p>If F 2 0 0 is set to 1, [Remote spd ref 2] (F 2 0 7) is the speed reference source when the drive's output frequency is 1 Hz or below. See diagram on page 50 for more detail.</p>		

Code	Name / Description	Adjustment range	Factory setting
F 6 5 0	[Forced fire control]	-	0
⚠ WARNING			
LOSS OF CONTROL			
<p>The value of F 6 5 0 will impact the direction of the motor.</p> <ul style="list-style-type: none"> - Check wiring motor power UVW is correct. - Verify that the value of F 6 5 0 is convenient for this application. <p>Failure to follow these instructions can result in death, serious injury, or equipment damage.</p>			
0	[Disable]		
1	[Enable forward]		
2	[Enable Reverse]		
<p>To enable Forced fire control, set parameter F 6 5 0 to 1 or 2 and assign a logic input to function 52 or 53 (see page 104). When parameter F 6 5 0 is set to 1 or 2, the embedded display will briefly flash the code F i r E.</p> <p>If parameter F 6 5 0 is set to 1 or 2 and a logic input assigned to function 52 or 53 is activated, the drive will run at the frequency set by parameter [Forced speed freq.] (F 2 9 4) (see below).</p> <p>Note:</p> <ul style="list-style-type: none"> • First set [Motor direction] (F 3 1 1) page 96 to allow forward or reverse operation. • Push the ENT button for 2 sec to complete the setting. • See F 6 5 9 for more information of the behavior. 			
F 6 5 9	[Forced fire function]	-	0
0	[Enable transition]	<p>When parameter F 6 5 9 is set to 0, the function is enabling on transition 0 -->1 of the logic input. The transition 1 -->0 will not disable the function.</p>	
⚠ WARNING			
LOSS OF CONTROL			
<p>If the Forced fire mode on logic input (function 52) has been enabled and F 6 5 9 is set to 0, the drive will run and only removing power from the drive will stop it.</p> <p>If the Fire mode on logic input (function 53) has been enabled and F 6 5 9 is set to 0, the drive will run and only removing power from the drive or a fault detection or a pressing on the STOP key on the display terminal will stop the drive.</p> <p>Check that this value of F 6 5 9 is convenient for the application.</p> <p>Failure to follow these instructions can result in death, serious injury, or equipment damage.</p>			
1	[Enable level 1]	<p>When parameter F 6 5 9 is set to 1, if the logic input is set to 0 the function is disabled.</p> <p>If the logic input is set to 1 the function is enable</p>	
⚠ WARNING			
RISK OF APPLICATION MALFUNCTION			
<p>When F 6 5 9 is set to 1 for safety reason, the forced mode will be inhibited if the logic input is inactivated for any reason (order removed, input broken, wiring contact lost).</p> <ul style="list-style-type: none"> - Check that this value of F 6 5 9 is convenient for the application. - If you need to continue to run if forced mode in any circumstance, select an other value of F 6 5 9. <p>Failure to follow these instructions can result in death, serious injury, or equipment damage.</p>			
2	[Enable level 0]	<p>When parameter F 6 5 9 is set to 2, if the logic input is set to 1 the function is disabled.</p> <p>If the logic input is set to 0 the function is enable.</p>	
⚠ DANGER			
UNINTENDED EQUIPMENT OPERATION			
<p>When F 6 5 9 is set to 2 for safety reason, the motor will run at Forced speed F 2 9 4 in case of intempetive wire disconnection.</p> <ul style="list-style-type: none"> - Check and control the wiring connection periodically. - Protect the signal conductors against damage that could result in unintentional conductor grounding. <p>Failure to follow these instructions will result in death or serious injury.</p>			
F 2 9 4	[Forced speed freq.]	LL - uL	50.0 Hz
<p>The F 2 9 4 parameter is used to set the fixed frequency command for the drive when it is in Forced or Fire mode.</p>			

Code	Name / Description	Adjustment range	Factory setting
F 730	[Up/down key ref] The setting of parameter F 730 determines whether it is possible to set the drive's speed by means of the embedded display terminal in local mode. 0 [Enable] 1 [Disable]		0
F 732	[Loc/rem key] Use parameter F 732 to enable or disable the LOC/REM key on the drive embedded display terminal. If the LOC/REM key is disabled, switching between local and remote mode can be achieved with parameters [Frequency mode sel] (F P o d) and [Command mode sel] (C P o d). See page 87 . 0 [Permitted memo]: still retained with the power off. 1 [Prohibited] 2 [Permitted no memo]: cancelled with the power off.		0
F 733	[Run/stop key] The setting of parameter F 733 determines whether it is possible to start and stop the drive by the Run/Stop keys located on the drive and graphic display option. 0 [Enable] 1 [Disable]		0
F 734	[Priority stop] <div style="text-align: center;">⚠ WARNING</div> LOSS OF CONTROL You are going to disable the stop button located on the drive and graphic display option Do not select 1 unless exterior stopping methods exist. Failure to follow these instructions can result in death, serious injury, or equipment damage. The setting of parameter F 734 determines whether it is possible to stop the drive by the Stop key located on the drive and graphic display option. 0 [Enable] 1 [Disable]		0
F 735	[HMI reset button] The setting of parameter [HMI reset button] (F 735) determines whether it is possible to clear a drive detected fault by means of the embedded display terminal STOP key (see page 55 for more detail). 0 [Enable] 1 [Disable]		1

Application Parameters



What's in this Chapter?

This chapter contains the following topics:

Topic	Page
Skip Frequencies	97
DC Injection Braking Parameters	98

Application parameters

Code	Name / Description	Adjustment range	Factory setting
F H	[Max frequency] Maximum Frequency	30.0 Hz to 200.0 Hz	50.0 Hz
	<p>If [Driving Scroll] (F324) page 160 is set to [yes] (1) the setting is replaced by 90%.</p> <p>The setting of parameter F H determines the maximum output frequency of the drive.</p> <p>F H limits the setting of parameter [Upper limit freq] (u L) (see page 92), which can be adjusted while the drive is operating. Acceleration and deceleration rates are also affected by the setting of F H, as the definition of [Acceleration time 1] (A C C) or [Deceleration time 1] (d E C) (see page 93) is the time it takes for the drive to ramp the motor up or down between zero speed and the setting of F H.</p> <p>F H can only be adjusted while the drive is stopped.</p> <div style="display: flex; justify-content: space-around;"> <div style="text-align: center;"> <p>Output frequency (Hz)</p> </div> <div style="text-align: center;"> <p>Output frequency (Hz)</p> </div> </div> <p>Note: When the stall prevention function /the overvoltage limit operation operates, the inverter may drive beyond the maximum frequency [Max frequency] (F H).</p>		
u L	[Upper limit freq] High speed	0.5 to [Max frequency] (F H)	50.0 Hz
	<p>If [Driving Scroll] (F324) page 160 is set to [yes] (1) the setting is replaced by 90%.</p> <p>Parameter u L sets the maximum frequency that can be commanded to the drive by the local or remote speed reference source. The top end of its range is limited by the setting of Maximum frequency [Max frequency] (F H). See diagram above.</p> <p>Note: When the stall prevention function /the overvoltage limit operation operates, the inverter may drive beyond the upper limit frequency [Upper limit freq] (u L).</p>		
L L	[Low limit frequency] Low speed	0.0 to [Upper limit freq] (u L)	0.0 Hz
	<p>If [Driving Scroll] (F324) page 160 is set to [yes] (1) the setting is replaced by 30%.</p> <p>Parameter L L sets the minimum frequency that can be commanded to the drive by the local or remote speed reference source. See diagram above.</p> <p>Note: When the stall prevention function /the overvoltage limit operation operates, the inverter may drive beyond the low limit frequency [Low limit frequency] (L L).</p>		
F 2 4 0	[Mot start freq.] Output Starting Frequency	0.5 to 10.0 Hz	0.5 Hz
	<p>The setting of parameter F 2 4 0 determines the drive's output frequency at the moment it receives a start command. There is no acceleration time to reach the parameter F 2 4 0 level.</p> <p>Parameter F 2 4 0 is typically set for the rated slip frequency of the motor. This allows motor torque to be generated as soon as a start command is given. Adjust parameter F 2 4 0 when a delay in the motor's response to a start command adversely affects the application.</p> <p>To determine the motor's slip frequency:</p> <ol style="list-style-type: none"> 1) Subtract the motor's rated speed at full load from its no-load speed (in rpm). 2) Divide the result by the no-load speed. 3) Multiply this result by the motor's rated frequency in Hz. <p>Example: Motor no-load speed = 1500 rpm Motor rated speed at full load = 1450 rpm Motor rated frequency = 50 Hz</p> <p>1500 rpm – 1450 rpm = 50 rpm 50 rpm / 1500 rpm = 3.33% 50 Hz x 0.0333 = 1.7 Hz (motor slip frequency)</p>		

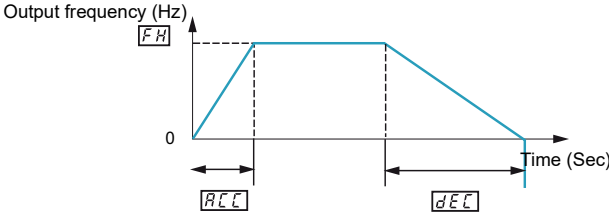
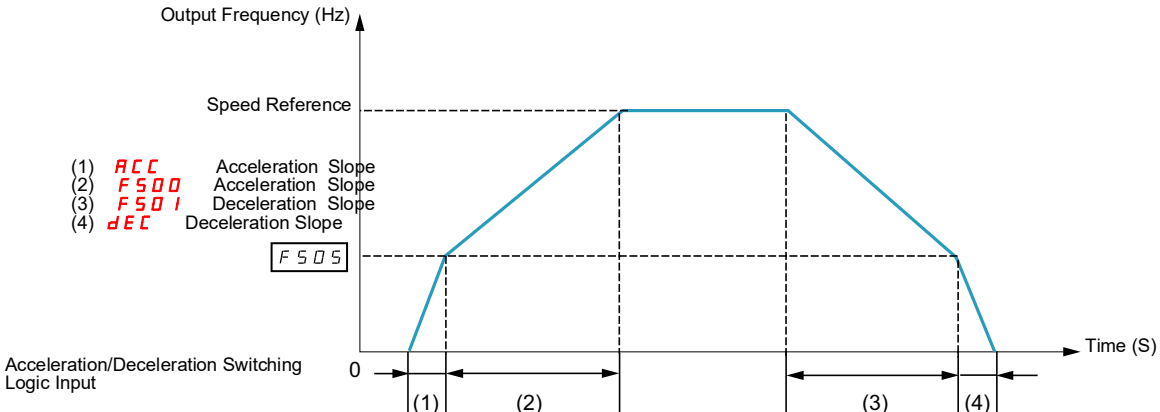
Code	Name / Description	Adjustment range	Factory setting
<i>A C C</i>	<p>[Acceleration time 1]</p> <p>If [Driving Scroll] (F324) page 160 is set to [yes] (1) the setting is replaced by 0.9 s.</p> <p>The setting of parameter <i>A C C</i> determines the slope of the acceleration ramp and the time it takes for the output frequency of the drive to increase from 0 Hz to the setting of [Max frequency] (<i>F H</i>) (see page 92).</p> <p>If parameter [Auto ramp] (<i>A U I</i>) (see page 95) is set to 1 or 2, the acceleration ramp may be increased or decreased from the setting of <i>A C C</i>, depending on the amount of load on the motor during ramp up.</p> <p>If two different acceleration rates are needed, see parameter [Acceleration time 2] (<i>F 5 0 0</i>) on page 93.</p> 	0.0 to 3200 s	According to drive rating (5)
<i>d E C</i>	<p>[Deceleration time 1]</p> <p>If [Driving Scroll] (F324) page 160 is set to [yes] (1) the setting is replaced by 0.9 s.</p> <p>The setting of parameter <i>d E C</i> determines the slope of the deceleration ramp and the time it takes for the output frequency of the drive to decrease from the setting of [Max frequency] (<i>F H</i>) to 0 Hz.</p> <p>If parameter [Auto ramp] (<i>A U I</i>) is set to 1, the deceleration ramp may be increased or decreased from the setting of <i>d E C</i>, depending on the amount of load on the motor during ramp down. See diagram above.</p> <p>If two different deceleration rates are needed, see parameter [Deceleration time 2] (<i>F 5 0 1</i>) on page 93.</p>	0.0 to 3200 s	According to drive rating (5)
<i>F 5 0 0</i>	<p>[Acceleration time 2]</p> <p>Parameter <i>F 5 0 0</i> sets the second acceleration time. Switching between acceleration rates 1 and 2 is accomplished by means of:</p> <p>Parameter [Ramp switching] (<i>F 5 0 4</i>) (see page 95),</p> <p>A particular operating frequency (see parameter [Comm. ramp freq.] (<i>F 5 0 5</i>) on page 95), or</p> <p>A logic input assigned to functions 5, 20, 21, 30, 31 – 35, or 40 (see table beginning on page 101)</p> 	0.0 to 3200 s	20.0 s
<i>F 5 0 1</i>	<p>[Deceleration time 2]</p> <p>Parameter <i>F 5 0 1</i> sets the second deceleration time. Switching between deceleration rates 1 and 2 is accomplished by means of:</p> <ul style="list-style-type: none"> - Parameter [Ramp switching] (<i>F 5 0 4</i>) (see page 95), - A particular operating frequency (see parameter [Comm. ramp freq.] (<i>F 5 0 5</i>) on page 95), or - A logic input assigned to functions 5, 20, 21, 30, 31 – 35, or 40 (see table beginning on page 101). 	0.0 to 3200 s	20.0 s

(5) See table page 199.

Code	Name / Description	Adjustment range	Factory setting
F 5 0 2 0 1 2	<p>[Acc/dec 1 pattern]</p> <p>[Linear] [S-ramp 1] (see diagram below) [S-ramp 2] (see diagram below for [Acc/dec 2 pattern] (F 5 0 3) parameter).</p> <p>The linear acceleration and deceleration pattern is illustrated in diagram on page 93 and is used in most applications. S-pattern 1 (see diagram below) is for use in applications that need the shortest ramp time possible while minimizing jerks during speed changes. See below for more information about parameters [Acc/Dec S-pat start] (F 5 0 6) and [Acc/Dec S-pat end] (F 5 0 7).</p>		0
F 5 0 3 0 1 2	<p>[Acc/dec 2 pattern]</p> <p>[Linear] [S-ramp 1] See diagram below. [S-ramp 2] See previous diagram for parameter Acc/Dec Pattern 1 [Acc/dec 1 pattern] (F 5 0 2).</p> <p>S-pattern 2 (diagram below) is for use in high-speed spindle applications where acceleration and deceleration rates need to be reduced as the motor operates above its rated operating frequency—a constant hp region where motor torque is reduced. Use parameter F 5 0 3 to select the second Acc/Dec pattern. Switching between Acc/Dec patterns 1 and 2 is accomplished by means of:</p> <p>Parameter [Ramp switching] (F 5 0 4) (see page 95), A particular operating frequency (see parameter [Comm. ramp freq.] (F 5 0 5) on page 95), or A logic input assigned to functions 5, 20, 21, 30, 31 – 35, or 40 (see table beginning on page 101).</p> <p>For more information on Acc/Dec patterns, see parameter [Acc/dec 1 pattern] (F 5 0 2) above.</p>		0
F 5 0 6	<p>[Acc/Dec S-pat start] Acc/Dec S-pattern lower limit</p> <p>Use parameter F 5 0 6 to adjust the lower portion of S-pattern 1. See diagram on page 95.</p>	0 to 50% of acceleration time	10%
F 5 0 7	<p>[Acc/Dec S-pat end] Acc/Dec S-pattern Upper Limit</p> <p>Use parameter F 5 0 7 to adjust the upper portion of the S-pattern 1. See diagram on page 95.</p>	0 to 50% of acceleration time	10%

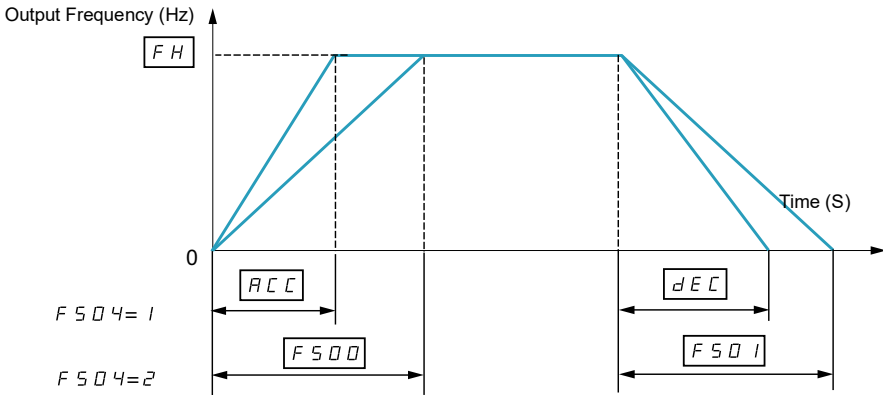
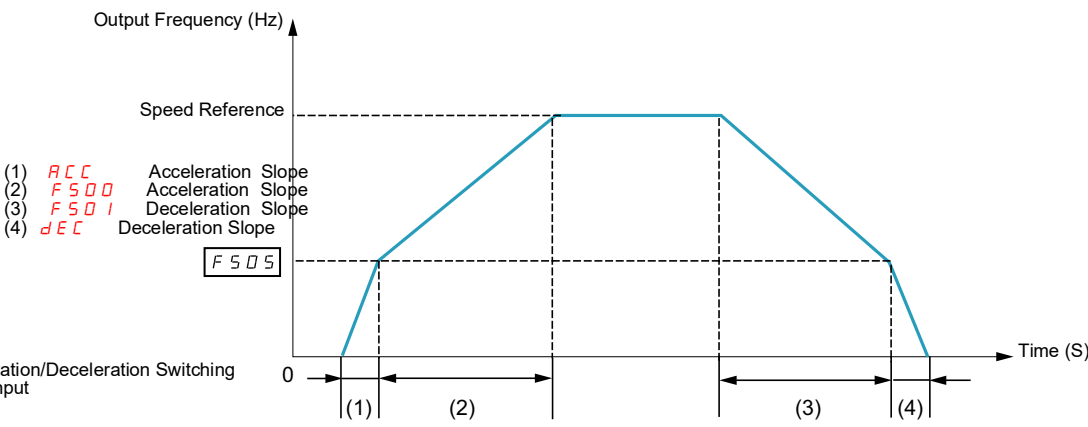
Code	Name / Description	Adjustment range	Factory setting
F504 1 2	[Ramp switching] Acc/Dec Pattern Selection Parameter F504 determines the Acc/Dec pattern. 	-	1
F505	[Commut. ramp freq.] Acc/Dec pattern switching frequency If parameter F505 is set to a frequency greater than 0.0, the drive will use Acc/Dec pattern 1 above that frequency and Acc/Dec pattern 2 above. 	0.0 to [Upper limit freq] (UL) (Hz)	0.0 Hz
Au1 0 1 2	[Auto ramp] Auto ramp adaptation If parameter Au1 is set to 1 or 2, the drive will monitor its own loading level and optimize the acceleration and deceleration ramps. The acceleration and deceleration (Au1 = 1 only) rates will be automatically adjusted between 1/8 to 8 times the settings of [Acceleration time 1] (ACC) and [Deceleration time 1] (DEC) , depending on the drive's current rating and the load level on the motor. ACC and DEC should be appropriately set for an average load in the application. If the load on the motor increases rapidly during ramp up or ramp down, the auto ramp adaptation feature may not help prevent the drive from experiencing an over-current or overvoltage. If the application requires a consistent acceleration and deceleration time, set Au1 to 0, and set ACC and DEC manually as needed. The manual acceleration and deceleration times can still be overridden by the [Motor Current Limit] (F601) (see page 73) and [Overvoltage fault] (F305) (see page 139) and [Overvoltage level] (F625) (see page 139) functions.		1
F300	[Switch. freq. level] Switching Frequency Level Increasing the switching frequency may reduce audible motor noise. Increasing the switching frequency will increase the heat dissipated by the drive. The capacity of the drive may need to be derated accordingly if the switching frequency is increased. See the derating curves in the AT212 Installation Manual.	6.0 to 16.0 kHz in 0.1 kHz steps	According to drive rating (1)

(5) See table page 199.

Code	Name / Description	Adjustment range	Factory setting
F 3 1 1	[Motor direction] Use parameter F 3 1 1 to permit only forward or reverse operation. If [Driving Scroll] (F324) page 90 is set to [yes] (1) the setting is replaced by [FW only] (1). 0 [Fw & Rev.] 1 [Fw only] 2 [Rev. only]	-	1
F 3 1 2	[Noise reduction] Switching Frequency Random Mode Random control of the switching frequency may reduce audible motor noise. Random control of the switching frequency will not be performed if the switching frequency is set above 7.1 kHz, regardless of the setting of F 3 1 2 . 0 [Disable] 1 [Enable]		0
F 3 1 6	[Switch. freq. mode] Switching frequency control mode 0 [Fixed] - ATV212●●●M3X and ATV212●●●N4: switching frequency NOT automatically reduced 1 [Auto] - ATV212●●●M3X and ATV212●●●N4: switching frequency automatically reduced 2 [460 V fixed] - ATV212●●●N4 (2): switching frequency NOT automatically reduced 3 [460 V Auto] - ATV212●●●N4 (2): switching frequency automatically reduced If parameter F 3 1 6 is set to 1 or 3, the switching frequency level will be automatically controlled to help prevent a drive overheating. If the drive senses an impending overheating, it will reduce the switching frequency, thus reducing heat produced by the controller. As the temperature approaches normal, the switching frequency will return to the level selected by parameter [Switch. freq. level] (F 3 0 0). If F 3 1 6 is set to 1 or 3, motor control performance is optimized if parameter F 3 0 0 is set to 6 kHz or 8 kHz.		1

(1) See table page 200.

(2) For 400 V applications with motor leads longer than 30 m (100 ft).

Skip Frequencies

Do not set the skip frequency bands so that they overlap.

While the drive will not operate within these skip frequency bands during steady state operation, skip frequency bands are ignored by the drive during motor acceleration and deceleration.

Code	Name / Description	Adjustment range	Factory setting
F 2 7 0	[Jump frequency 1] Skip frequency 1 midpoint	0.0 to [Max frequency] (F H)	0.0 Hz
F 2 7 1	[Jump bandwidth 1] Skip frequency 1 bandwidth	0.0 to 30.0 Hz	0.0 Hz
F 2 7 2	[Jump frequency 2] Skip frequency 2 midpoint	0.0 to [Max frequency] (F H)	0.0 Hz
F 2 7 3	[Jump bandwidth 2] Skip frequency 2 bandwidth	0.0 to 30.0 Hz	0.0 Hz
F 2 7 4	[Jump frequency 3] Skip frequency 3 midpoint	0.0 to [Max frequency] (F H)	0.0 Hz
F 2 7 5	[Jump bandwidth 3] Skip frequency 3 bandwidth	0.0 to 30.0 Hz	0.0 Hz

DC Injection Braking Parameters

The drive can inject DC current into the motor to apply braking torque to the load. Parameters [DC brake start freq.] (*F 2 5 0*), [DC braking current] (*F 2 5 1*) and [DC braking time] (*F 2 5 2*) determine the Output Starting Frequency, current level, and braking time.

During DC injection braking, the drive's switching frequency is 6 kHz regardless of the setting of parameter [Switch. freq. level] (*F 3 0 0*) (see page 95).

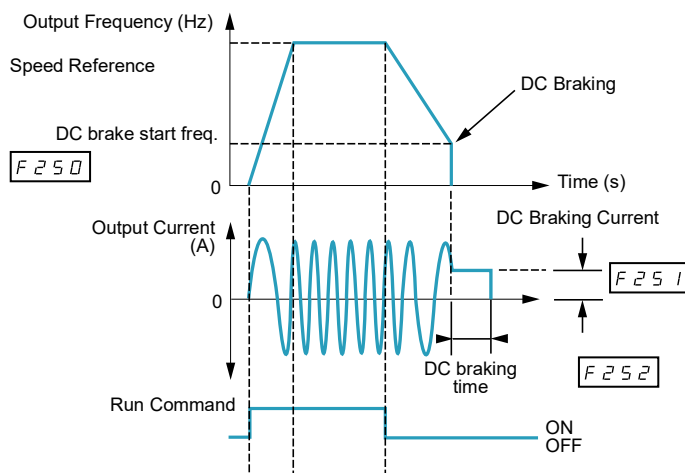

Code	Name / Description	Adjustment range	Factory setting
<i>F 2 5 0</i>	[DC brake start freq.]	0.0 to [Max frequency] (<i>F H</i>)	0.0 Hz
⚠ WARNING			
NO HOLDING TORQUE			
<ul style="list-style-type: none"> • DC injection braking does not provide holding torque at zero speed. • DC injection braking does not work when there is a loss of power or when the drive detects a fault. • When necessary, use a separate brake to maintain torque levels. 			
Failure to follow these instructions can result in death, serious injury, or equipment damage.			
When stopping the motor, the drive will apply DC injection braking once the output frequency drops below the level set by parameter <i>F 2 5 0</i> .			
<i>F 2 5 1</i>	[DC braking current] DC braking current level	0 to 100%	50% (1)
NOTICE			
RISK OF DAMAGE TO THE MOTOR			
Check that the motor will withstand this current without overheating.			
Failure to follow this instruction can result in equipment damage.			
Parameter <i>F 2 5 1</i> sets the level of current applied to the motor during DC injection braking. The displayed value, percent or amperes, is set by parameter [Unit value selection] (<i>F 7 0 1</i>) (see page 130).			
During DC injection braking, the drive's overload protection sensitivity increases. The drive automatically lowers the applied DC current to avoid an overload detected fault.			
<i>F 2 5 2</i>	[DC braking time]	0.0 to 20.0 s	1.0 s
NOTICE			
RISK OF DAMAGE TO THE MOTOR			
<ul style="list-style-type: none"> • Long periods of DC injection braking can cause overheating and damage the motor. • Protect the motor by avoiding long periods of DC injection braking. 			
Failure to follow this instruction can result in equipment damage.			
Parameter <i>F 2 5 2</i> determines how long DC injection braking is applied to the motor.			

(1) Percentage of the drive's rated current or ampere range. This will vary according to drive power rating.

I/O Control Parameters

8

What's in this Chapter?

This chapter contains the following topics:

Topic	Page
Logic Inputs Functions	100
Logic Input Function Compatibility	107
Relay Output Functions	108
Analog Input Functions	114
Analog Output Functions	115
Analog Input Adjustments	116
Active Logic Function	122
Preset Speeds	123
+/- Speed Control Parameters	124
Damper control	127

Logic Inputs Functions

See table on page [101](#) for a complete list of F, R and RES logic inputs assignments

Code	Name / Description	Adjustment range	Factory setting
F 1 1 1	[LI F selection] F Logic Input Function	0 to 73	2
	The setting of parameter F 1 1 1 determines the control function of logic input terminal F.		
F 1 1 2	[LI R selection] R Logic Input Function	0 to 73	6
	The setting of parameter F 1 1 2 determines the control function of logic input terminal R.		
F 1 1 3	[LI RES selection] RES Logic Input Function	0 to 73	10
	If [Driving Scroll] (F324) page 160 is set to [yes] (1) the setting is replaced by [Inverse Run permis.] (54) .		
	The setting of parameter F 1 1 3 determines the control function of logic input terminal RES.		
F 1 0 9	[VIA selection] VIA Input Function (Analog or Logic Selection)	-	0
	<div style="background-color: black; color: white; padding: 5px; font-weight: bold; font-size: 1.2em;"> ⚠ DANGER </div>		
	<p>UNINTENDED EQUIPMENT OPERATION</p> <p>Prevent accidental grounding of logic inputs configured for sink logic. Accidental grounding can result in unintended activation of drive functions.</p> <p>Protect the signal conductors against damage that could result in unintentional conductor grounding.</p> <p>Failure to follow these instructions will result in death or serious injury.</p>		
0	[AI]: Analog input		
1	[LI sink]: Logic input - sink (negative logic)		
2	[LI source]: Logic input - source (positive logic)		
	The setting of parameter F 1 0 9 determines whether control input terminal VIA will serve as an analog input (0-10 Vdc or 0-20 mA) or as a logic input (either sink or source).		
	When configuring VIA as a logic input, be certain to slide switch SW100 on the main control board to the V (voltage) position. When configuring VIA as a logic input using sink (negative) logic, be certain to connect a 4.7 kΩ (1/2 W) resistor between control terminals P24 and VIA.		
	For more information on the use of control input terminal VIA, see ATV212 Installation manual.		
F 1 1 8	[VIA LI selection] VIA Logic Input Function	0 to 73	7
	Set first parameter [VIA selection] (F 1 0 9) before setting parameter F 1 1 8 . The setting of parameter F 1 1 8 determines the control function of logic input terminal VIA.		
	See page 101 for a complete list of VIA logic input assignments.		

Logic inputs F, R, RES, and VIA (if parameter [VIA selection] (F I D 9) is set to 1 or 2) can be set to the functions described in the table below. See table on page 107 for logic input function compatibility.

Function		Action			
No.	Description				
0	[No assigned] No function assigned	Logic input disabled			
1	[Run permissive] (see also input function 54, page 105)	OFF: drive motor output disabled, motor coasts to stop ON: drive ready for operation If [Logic Funct 2 active] (F I I D) is not set to 1 [Run permissive], a logic input should be assigned to the [Run permissive] logic function to enable the motor to start.			
2	[Forward] (2-wire control: input function 49 NOT used) or (3-wire control: input function 49 USED)	Mode	Logic Input Action		
		2-wire control	OFF: Motor ramps down to a stop ON: Motor runs forward		
		Mode	Stop Input State	Logic Input Action	
		3-wire control	OFF	OFF: no function ON: no function	
3-wire control	ON	OFF to ON transition starts the drive, motor runs forward			
3	[Reverse] (2-wire control: input function 49 NOT used) or (3-wire control: input function 49 USED)	Mode	Logic Input Action		
		2-wire control	OFF: Motor ramps down to a stop ON: Motor runs reverse		
		Mode	Stop Input State	Logic Input Action	
		3-wire control	OFF	OFF: no function ON: no function	
3-wire control	ON	OFF to ON transition starts the drive, motor runs in reverse			
5	[Acc / Dec]	OFF: Acceleration/deceleration pattern 1 ON: Acceleration/deceleration pattern 2			
6	[PS1] Preset speed command input 1	Input 3	Input 2	Input 1	Motor Speed
		0	0	0	minimum speed or speed reference per [Frequency mode sel] (F P o d)
		0	0	1	S r 1: preset speed 1
7	[PS2] Preset speed command input 2	0	1	0	S r 2: preset speed 2
		0	1	1	S r 3: preset speed 3
		1	0	0	S r 4: preset speed 4
8	[PS3] Preset speed command input 3	1	0	1	S r 5: preset speed 5
		1	1	0	S r 6: preset speed 6
		1	1	1	S r 7: preset speed 7
10	[Fault reset] (see also input function 55, page 105)	<div style="text-align: center; background-color: black; color: white; padding: 5px;">⚠ DANGER</div> <div style="border: 1px solid black; padding: 5px;"> <p>UNINTENDED EQUIPMENT OPERATION</p> <p>This configuration enables to reset the drive. Check this action will not endanger personnel or equipment in any way</p> <p>Failure to follow these instructions will result in death or serious injury.</p> </div> <p>ON to OFF transition clears a detected fault (if cause of detected fault has been cleared)</p>			
11	[Ext Fault] (see also input function 45, page 104)	OFF: No external detected fault ON: Motor stops according to method set by parameter [Ext. fault stop Mode] (F B D 3) Embedded display terminal displays E detected fault, detected fault relay activated			

Function		Action
No.	Description	
13	[DC braking]	<div style="border: 1px solid black; padding: 10px; text-align: center;"> <h2 style="margin: 0;">⚠ WARNING</h2> <p>NO HOLDING TORQUE</p> <ul style="list-style-type: none"> ● DC injection braking does not provide any holding torque at zero speed. ● DC injection braking does not work when there is a loss of power or when the drive detects a fault. ● Where necessary, use a separate brake to maintain torque levels. <p>Failure to follow these instructions can result in death, serious injury, or equipment damage.</p> </div> <p>OFF: No DC braking command ON: DC braking applied to motor, Level and time set by parameters [DC braking current] (<i>F 2 5 1</i>) and [DC braking time] (<i>F 2 5 2</i>)</p>
14	[PID disable]	<p>OFF: PID control permitted ON: PID control prohibited</p> <p>PID control prohibited input terminal function is available to switch PID control and open-loop control.</p> <p>Also Clear PID integral value input terminal function (function 65) is available.</p> <p>Note: For software version lower than V1.71E04, when Clear PID integral value (function 65) and PID Control Prohibited (function 14) are used, it is necessary to set [Command mode sel] (<i>C P o d</i>) to [Logic inputs] (<i>o</i>) Control terminal logic inputs.</p>
15	[Param Edit] Functional only when parameter [Parameter lock] (<i>F 7 0 0</i>) = 1	<p>OFF: Parameters locked (if parameter <i>F 7 0 0</i> = 1) ON: Programming changes permitted</p>
16	[Run reset]	<p>OFF: drive motor output disabled, motor coasts to stop ON: drive ready for operation ON to OFF transition clears a detected fault (if cause of detected fault has cleared)</p>
20	[FW-RMP2] Combination of forward run command and acceleration/deceleration/deceleration pattern 2 selection	<p>OFF: Motor stops, ramping down per ACC/dEC pattern 2 ON: Motor runs forward, ramping up per ACC/dEC pattern 2</p>
21	[Rev- RMP2] Combination of reverse run command and acceleration/deceleration pattern 2 selection	<p>OFF: Motor stops, ramping down per ACC/dEC pattern 2 ON: Motor runs in reverse, ramping up per ACC/dEC pattern 2</p>
22	[FW, PS1] Combination of forward run command and preset speed 1 command	<p>OFF: Motor ramps down to a stop ON: Motor runs forward, at speed set by <i>S r 1</i>, preset speed 1</p>
23	[RV, PS1] Combination of reverse run command and preset speed 1 command	<p>OFF: Motor ramps down to a stop ON: Motor runs in reverse, at speed set by <i>S r 1</i>, preset speed 1</p>
24	[FW, PS2] Combination of forward run command and preset speed 2 command	<p>OFF: Motor ramps down to a stop ON: Motor runs forward, at speed set by <i>S r 2</i>, preset speed 2</p>
25	[RV, PS2] Combination of reverse run command and preset speed 2 command	<p>OFF: Motor ramps down to a stop ON: Motor runs in reverse, at speed set by <i>S r 2</i>, preset speed 2</p>
26	[FW, PS3] Combination of forward run command and preset speed 3 command	<p>OFF: Motor ramps down to a stop ON: Motor runs forward, at speed set by <i>S r 3</i>, preset speed 3</p>

Function		Action
No.	Description	
27	[RV, PS3] Combination of reverse run command and preset speed 3 command	OFF: Motor ramps down to a stop ON: Motor runs in reverse, at speed set by <i>S r 3</i> , preset speed 3
30	[FW-RMP2-SP1] Combination of forward run command, preset speed 1 command, and acceleration/deceleration pattern 2 selection	OFF: Motor stops, ramping down per ACC/dEC pattern 2 ON: Motor runs forward, at speed set by <i>S r 1</i> , preset speed 1, ramping up per ACC/dEC pattern 2
31	[Rev-RMP2-SP1] Combination of reverse run command, preset speed 1 command, and acceleration/deceleration pattern 2 selection	OFF: Motor stops, ramping down per ACC/dEC pattern 2 ON: Motor runs in reverse, at speed set by <i>S r 1</i> , preset speed 1, ramping up per ACC/dEC pattern 2
32	[FW-RMP2-SP2] Combination of forward run command, preset speed 2 command, and acceleration/deceleration pattern 2 selection	OFF: Motor stops, ramping down per ACC/dEC pattern 2 ON: Motor runs forward, at speed set by <i>S r 2</i> , preset speed 2, ramping up per ACC/dEC pattern 2
33	[Rev-RMP2-SP2] Combination of reverse run command, preset speed 2 command, and acceleration/deceleration pattern 2 selection	OFF: Motor stops, ramping down per ACC/dEC pattern 2 ON: Motor runs in reverse, at speed set by <i>S r 2</i> , preset speed 2, ramping up per ACC/dEC pattern 2
34	[FW-RMP2-SP3] Combination of forward run command, preset speed 3 command, and acceleration/deceleration pattern 2 selection	OFF: Motor stops, ramping down per ACC/dEC pattern 2 ON: Motor runs forward, at speed set by <i>S r 3</i> , preset speed 3, ramping up per ACC/dEC pattern 2
35	[Rev-RMP2-SP3] Combination of reverse run command, preset speed 3 command, and acceleration/deceleration pattern 2 selection	OFF: Motor stops, ramping down per ACC/dEC pattern 2 ON: Motor runs in reverse, at speed set by <i>S r 3</i> , preset speed 3, ramping up per ACC/dEC pattern 2
38	[Frequency source] Frequency reference source switching	OFF: drive follows speed reference set by parameter [Frequency mode sel] (<i>F P o d</i>) ON: drive follows speed reference set by parameter [Remote spd ref 2] (<i>F 2 0 7</i>) > (if [Auto/man speed ref] (<i>F 2 0 0</i>) = 1)
39	[Motor switch]	<div style="text-align: center;">NOTICE</div> <div style="border: 1px solid black; padding: 5px;"> <p>RISK OF DAMAGE TO THE MOTOR</p> <ul style="list-style-type: none"> • The motor switching function disables motor thermal protection. • The use of external overload protection is required when using motor switching. <p>Failure to follow these instructions can result in death, serious injury, or equipment damage.</p> </div> <p>OFF: 1st motor V/Hz parameter set active: ([Mot cont. mode sel.] (<i>P k</i>), [Motor rated freq.] (<i>u L</i>), [Motor rated voltage] (<i>u L u</i>), [Mot Voltage Boost] (<i>u b</i>), [Motor thermal prot.] (<i>t H r</i>))</p> <p>ON: 2nd motor V/Hz parameter set active: (<i>P k</i> = 0, <i>F 1 7 0</i>, <i>F 1 7 1</i>, <i>F 1 7 2</i>, <i>F 1 7 3</i>)</p>

Function		Action
No.	Description	
40	[Mot param. switch] Motor control parameter switching V/Hz, current limit, acceleration/deceleration pattern	<div style="text-align: center;">NOTICE</div> <p>RISK OF DAMAGE TO THE MOTOR</p> <ul style="list-style-type: none"> • The parameter switching function disables motor thermal protection. • The use of external overload protection is required when using motor switching. <p>Failure to follow these instructions can result in death, serious injury, or equipment damage.</p> <p>OFF: 1st motor control parameter set active: ([Mot cont. mode sel.] (P_L), [Motor rated freq.] (u_L), [Motor rated voltage] (u_L u), [Mot Voltage Boost] (u_b), [Motor thermal prot.] (t_H r), [Acceleration time 1] (R_L C), [Deceleration time 1] (d_E C), [Acc/dec 1 pattern] (F₅₀₂), [Motor Current Limit] (F₆₀₁))</p> <p>ON: 2nd motor control parameter set active: (P_L = 0, F₁₇₀, F₁₇₁, F₁₇₂, F₁₇₃, F₁₈₅, F₅₀₀, F₅₀₁, F₅₀₃)</p>
41	[(+ speed)]	OFF: No motor speed increase ON: Motor accelerates
42	[(- speed)]	OFF: No motor speed reduction ON: Motor decelerates
43	[+/- clear]	OFF to ON transition clears frequency level set by +/- speed inputs
44	[+/- SPD, FLT CLR]	OFF to ON transition clears frequency level set by +/- speed inputs ON to OFF transition clears a detected fault (if cause of detected fault has been cleared)
45	[Inv Ext. fault] Inversion of external detected fault signal (see also input function 11, page 101)	OFF: Motor stops according to method set by parameter [Ext. fault stop Mode] (F ₆₀₃) Embedded display terminal displays E detected fault ON: No external detected fault
46	[Ext. Th fault] External overheating input (see also input function 47)	OFF: No external overheating ON: Motor stops, embedded display terminal displays oH2
47	[Inv Ext. Th fault] Inversion of external overheating input (see also input function 46)	OFF: Motor stops, embedded display terminal displays oH2 ON: No external overheating
48	[Forced local]	OFF: No forced local function ON: Control of the drive is forced to mode set by [Frequency mode sel] (F _{10d}), [Command mode sel] (C _{10d}), and [Remote spd ref 2] (F ₂₀₇).
49	[3-wire]	OFF: Motor ramps down to a stop ON: drive ready for operation
51	[Reset kWh] Clear accumulated power consumption kWh display	OFF: No function ON: Clears kWh memory
52	[Forced mode]	<div style="text-align: center;">⚠ DANGER</div> <p>LOSS OF PERSONNEL AND EQUIPMENT PROTECTION</p> <p>When F₆₅₀ is set to 1 or 2 and a logic input set to function "52" is activated, all the drive controller protection will be disable.</p> <ul style="list-style-type: none"> • Logic input should not be enable on function 52 for typical applications... • Logic input should be enable on function 52 only in extraordinary situations where a thorough risk analysis demonstrates that the presence of adjustable speed drive protection poses a greater risk than personnel injury or equipment damage. <p>Failure to follow these instructions will result in death or serious injury.</p> <p>This function enables the "Forced fire" mode. In this mode, all the detected fault will be ignored or if it is a hardware trip, the drive will be reset to try to restart.</p> <p>OFF: No function ON: Motor runs at speed set by F₂₉₄</p> <p>Note: F₆₅₀, F₆₅₉ and F₂₉₄ must be configured to activate this function.</p>

Function		Action
No.	Description	
53	[Fire mode]	This function enables the "Fire" mode OFF: No function ON: Motor runs at speed set by <i>F 2 9 4</i> Note: <i>F 6 5 0</i> , <i>F 6 5 9</i> and <i>F 2 9 4</i> must be configured to activate this function.
54	[Inverse Run permis.] Inversion of run permissive (see also input function 1 page 101)	OFF: drive ready for operation ON: drive motor output disabled, motor coasts to stop This mode allows to have a freewheel stop using a terminal command.
55	[Inv fault reset] Inversion of clear detected fault (see also input function 10 page 101)	<div style="text-align: center; background-color: black; color: white; padding: 5px;">⚠ DANGER</div> <div style="border: 1px solid black; padding: 5px;">UNINTENDED EQUIPMENT OPERATION This configuration enables to reset the drive. Check this action will not endanger personnel or equipment in any way Failure to follow these instructions will result in death or serious injury.</div> <p>OFF to ON transition clears a detected fault (if cause of detected fault has been cleared)</p>
56	[Run, FW] Combination of run permissive and run forward command (2-wire control only)	OFF: drive motor output disabled, motor coasts to stop ON: Motor runs forward
57	[Run, RV] Combination of run permissive and run reverse command (2-wire control only)	OFF: drive motor output disabled, motor coasts to stop ON: Motor runs reverse
61	[I limit 1/2] Current limit level selection	OFF: Current limit level 1 [Motor Current Limit] (<i>F 6 0 1</i>) selected ON: Current limit level 2 [Mot. 2 current limit] (<i>F 1 8 5</i>) selected
62	[RY on] Holding of RYA-RYC relay output	OFF: Normal real-time relay operation ON: RYA-RYC is held on once activated
64	[Cancel HMI cmd] Cancellation of last graphic display option command	OFF: Last graphic display option command cancelled ON: Last graphic display option command retained
65	[PID integral] Clear PID integral value	OFF: No action ON: PID integral value held at zero
66	[Run-fw-sp1] Combination of run permissive, run forward command, and preset speed 1 command	OFF: drive motor output disabled, motor coasts to stop ON: Motor runs forward at speed set by <i>S r 1</i> , preset speed 1
67	[Run-rev-sp1] Combination of run permissive, run reverse command, and preset speed 1 command	OFF: drive motor output disabled, motor coasts to stop ON: Motor runs reverse at speed set by <i>S r 1</i> , preset speed 1
68	[Run-fw-sp2] Combination of run permissive, run forward command, and preset speed 2 command	OFF: drive motor output disabled, motor coasts to stop ON: Motor runs forward at speed set by <i>S r 2</i> , preset speed 2
69	[Run-rev-sp2] Combination of run permissive, run reverse command, and preset speed 2 command	OFF: drive motor output disabled, motor coasts to stop ON: Motor runs reverse at speed set by <i>S r 2</i> , preset speed 2

Function		Action
No.	Description	
70	[Run-fw-sp4] Combination of run permissive, run forward command, and preset speed 4 command	OFF: drive motor output disabled, motor coasts to stop ON: Motor runs forward at speed set by $Sr4$, preset speed 4
71	[Run-rev-sp4] Combination of run permissive, run reverse command, and preset speed 4 command	OFF: drive motor output disabled, motor coasts to stop ON: Motor runs reverse at speed set by $Sr4$, preset speed 4
72	[PID rev] PID error signal reversed	OFF: if $F111 = 72$ and F terminal is OFF, PI error input = reference - feedback ON: if $F111 = 72$ and F terminal is ON, PI error input = feedback - reference
73	[Damper feedBack]	OFF: if $F111$ or $F112$ or $F113$ is not set to 73 the damper has no effect. ON: if $F111$ or $F112$ or $F113 = 73$ the damper is ON. The damper feedback has not effect if not configured to an output.

Logic Input Function Compatibility

O = Compatible

X = Incompatible

+ = Compatible under some conditions

@ = Priority

Function No. / Function	1/54	2	3	5	6-9	10/5 5	11/4 5	13	14	15	46/4 7	48	41- 43	49	38	39	40	52/5 3
1/54 [No assigned] / [Inverse Run permissive]		@	@	@	@	O	O	@	O	O	O	O	O	@	O	O	O	X
2 [Forward]	+		X	O	O	O	X	X	O	O	X	O	O	X	O	O	O	X
3 [Reverse]	+	+		O	O	O	X	X	O	O	X	O	O	X	O	O	O	X
5 [Acc / Dec]	+	O	O		O	O	X	X	O	O	X	O	O	O	O	O	X	O
6~8 [PS1]~[PS3]	+	O	O	O		O	X	X	O	O	X	O	O	O	O	O	O	X
10/55 [Fault reset] / [Inv fault reset]	O	O	O	O	O		X	O	O	O	X	O	O	O	O	O	O	X
11/45 [Ext. fault] / [Inv. Ext. fault]	+	@	@	@	@	@		@	@	O	+	O	@	@	O	O	O	X
13 [DC braking]	+	@	@	@	@	O	X		@	O	X	O	@	@	O	O	O	X
14 [PID disable]	O	O	O	O	O	O	X	X		O	X	O	O	O	O	O	O	X
15 [Param Edit]	O	O	O	O	O	O	O	O	O		O	O	O	O	O	O	O	O
46/47 [Ext. Th fault] / [Inv Ext. Th fault]	@	@	@	@	@	@	+	@	@	O		O	O	@	O	O	O	X
48 [Forced local]	O	O	O	O	O	O	O	O	O	O	O		O	O	O	O	O	X
41-43 [(+) speed] [(-) speed] [+/- clear]	O	O	O	O	O	O	O	O	O	O	O	O		O	O	O	O	X
49 [3-wire]	+	@	@	O	O	O	X	X	O	O	X	O	O		O	O	O	X
38 [Frequency source]	O	O	O	O	O	O	O	O	O	O	O	O	O	O		O	O	X
39 [Motor switch]	O	O	O	O	O	O	O	O	O	O	O	O	O	O	O		X	O
40 [Mot param. switch]	O	O	O	@	O	O	O	O	O	O	O	O	O	O	O	@		O
52/53 [Forced mode] / [Fire mode]	@	@	@	O	@	@	@	@	@	O	@	@	@	@	@	O	O	

The following logic input functions are active, regardless of the [Frequency mode sel] (*F P o d*) and [Command mode sel] (*C P o d*) setting.

- (1) Run permissive
- (10) Clear detected fault
- (11) External detected fault

When determining function compatibility using the table above, the function listed horizontally is activated first and the function listed vertically is activated second.

Relay Output Functions

The two relay outputs (FL and RYA-RYC) can be set to the functions described in the table below.

Function No. / Description	Action
0 [Low speed reach] Low speed reached	OFF: output frequency is low speed setting [Low limit frequency] (LL) ON: output frequency is > low speed setting LL
1 [Inv low spd reach] Inversion of low speed reached	OFF: output frequency is > low speed setting [Low limit frequency] (LL) ON: output frequency is low speed setting LL
2 [High speed reach] High speed reached	OFF: output frequency is < high speed setting [Upper limit freq] (uL) ON: output frequency is high speed setting uL
3 [Inv Hi spd reach] Inversion of high speed reached	OFF: output frequency is high speed setting [Upper limit freq] (uL) ON: output frequency is < high speed setting uL
4 [F100 speed reach] F 100 speed reached (See page 125 for more details on parameter F 100)	OFF: output frequency is < [Freq. 1 reached] (F 100) speed setting ON: output frequency is F 100 speed setting
5 [Inv F100 sp reach] Inversion of F 100 speed reached	OFF: output frequency is [Freq. 1 reached] (F 100) speed setting ON: output frequency is < F 100 speed setting
6 [Speed reach] Commanded speed reached	OFF: output frequency is commanded speed +/- [Freq.2 bandw.] (F 102) hysteresis band ON: output frequency is > commanded speed +/- F 102 hysteresis band
7 [Inv speed reach] Inversion of commanded speed reached	OFF: output frequency is > commanded speed +/- [Freq.2 bandw.] (F 102) hysteresis band ON: output frequency is commanded speed +/- F 102 hysteresis band
8 [F101 speed reach] F 101 speed reached (See page 125 for more details on parameters F 101 and F 102.)	OFF: output frequency is [Freq. 2 reached] (F 101) speed +/- [Freq.2 bandw.] (F 102) hysteresis band ON: output frequency is > F 101 speed +/- F 102 hysteresis band
9 [Inv F101 sp reach] Inversion of F 101 speed reached	OFF: output frequency is > [Freq. 2 reached] (F 101) speed +/- [Freq.2 bandw.] (F 102) hysteresis band ON: output frequency is F 101 speed +/- F 102 hysteresis band
10 [Drive fault] Fault relay. The drive is not in a fault state during auto fault reset attempts. See also function 36 page 112.	<p>OFF: No drive detected fault ON: drive detected fault</p> <div style="border: 1px solid black; padding: 5px;"> <p style="text-align: center;">⚠ WARNING</p> <p>LOSS OF CONTROL</p> <ul style="list-style-type: none"> When F 130, F 132, F 137 is set to 10, the output will be active when the drive will detect a fault. The drive status will not be detected if the wiring is damaged for any reason. Do not select 10 unless you are sure that your signal will be present in any case. <p>Failure to follow these instructions can result in death, serious injury, or equipment damage.</p> </div>
11 [No drive fault] Inversion of Drive fault function.	OFF: drive detected fault ON: No drive detected fault
12 [Overload flt] Overtorque fault Overtorque fault detection is active only if parameter F 6 15 = 1. See page 143 for more detail on an overtorque detected fault and parameters F 6 16 and F 6 18.)	OFF: Estimated motor torque has NOT been at [Overtorque level] (F 6 16) level for a time period longer than that set by [Ovtorque det time] (F 6 18) ON: Estimated motor torque has been at F 6 16 level for a time period longer than that set by F 6 18. drive stopped, displaying o t
13 [Inv overload flt] Inversion of Overload flt function	OFF: Estimated motor torque has been at [Overtorque level] (F 6 16) level for a time period longer than that set by [Ovtorque det time] (F 6 18). drive stopped, displaying o t ON: Estimated motor torque has NOT been at F 6 16 level for a time period longer than that set by F 6 18

Function No. / Description		Action
14	[Drive running] Run relay	OFF: drive is not powering the motor ON: drive is powering the motor, accelerating, decelerating, at constant speed, or DC braking
15	[Drive no run] Inversion of Drive no run function	OFF: drive is powering the motor, accelerating, decelerating, at constant speed, or DC braking ON: drive is not powering the motor
16	[Motor overload] Motor overload alarm detection is only active if parameter $oL\pi$ is set to either 0, 1, 4, or 5. See page 146 for more detail on motor overload protection settings.	OFF: motor thermal state is < 50% of motor overload detected fault level ON: motor thermal state is 50% of motor overload detected fault level
17	[Inv mot. overload] Inversion of Motor overload function	OFF: motor thermal state is 50% of motor overload detected fault level ON: motor thermal state is < 50% of motor overload detected fault level
20	[Torque alarm] Overtorque alarm detection is active only if parameter $F 5 15 = 0$. See page 143 for more detail on the overtorque alarm and parameters [Overtorque level] ($F 5 15$), [Overtorque band] ($F 5 19$).	OFF: Estimated motor torque is < 70% of $F 5 15$ level minus $F 5 19$ hysteresis band ON: Estimated motor torque is 70% of $F 5 15$ level
21	[Inv torque alarm] Inversion of Torque alarm function	OFF: Estimated motor torque is 70% of [Overtorque level] ($F 5 15$) level ON: Estimated motor torque is < 70% of $F 5 15$ level minus [Overtorque band] ($F 5 19$) hysteresis band
22	[Gen. alarm] General alarm	OFF: No detected fault condition from the sources listed below exists ON: A detected fault has been issued by one of the following sources: <ul style="list-style-type: none"> Overtorque detected fault (output functions 12 and 13) Motor overload (output functions 16 and 17) Overtorque detected fault (output functions 20 and 21) Load detection loss (output functions 24 and 25) Run time (output functions 42 and 43) Undervoltage (output functions 54 and 55) drive in sleep mode (see for more detail on parameter $F 2 5 5$) Power loss (see for more detail on parameter $F 3 0 2$) Overcurrent – motor current limit level (parameter $F 5 0 1$) Overvoltage – DC bus voltage overvoltage stall level (parameter $F 5 2 5$) Drive overheating
23	[Inv gen. alarm] Inversion of General alarm function	OFF: A detected fault has been issued by one of the following sources: <ul style="list-style-type: none"> Overtorque detected fault (output functions 12 and 13) Motor overload (output functions 16 and 17) Overtorque detection loss (output functions 20 and 21) Failure of load detection (output functions 24 and 25) Run time (output functions 42 and 43) Undervoltage (output functions 54 and 55) Drive in sleep mode (see for more detail on parameter $F 2 5 5$) Power loss (see for more detail on parameter $F 3 0 2$) Overcurrent – motor current limit level (parameter $F 5 0 1$) Overvoltage – DC bus voltage overvoltage stall level (parameter $F 5 2 5$) drive overheating ON: No alarm condition from the sources listed above exists
24	[Underload detect.] (See page 141 for more detail on parameters $F 5 0 9 - F 5 1 2$ and the underload function.)	OFF: Motor current is greater than $F 5 1 1$ level + $F 5 0 9$ hysteresis band ON: Motor current is less than $F 5 1 1$ level for the time set by $F 5 1 2$
25	[Inv underl. det.] Inversion of Underload detect. function	OFF: Motor current is less than $F 5 1 1$ level for the time set by $F 5 1 2$ ON: Motor current is greater than $F 5 1 1$ level + $F 5 0 9$ hysteresis band

Function No. / Description	Action
<p>26 [Manu reset flt.] Non-autoresettable detected fault</p>	<p>OFF: None of the detected fault conditions listed below exist ON: One (or more) of the following detected fault conditions exists and has stopped the drive:</p> <ul style="list-style-type: none"> • <i>E</i> – external detected fault • <i>E - 1B</i> – VIA analog input signal detected fault • <i>E - 19</i> – main control board CPU communication • <i>E - 20</i> – excessive torque boost • <i>E - 21</i> – main control board CPU detected fault 2 • <i>EEP 1</i> – main control board EEPROM detected fault 1 • <i>EEP 2</i> – main control board EEPROM detected fault 2 • <i>EEP 3</i> – main control board EEPROM detected fault 3 • <i>EF 2</i> – ground detected fault • <i>EPHD</i> – output phase detected fault detection • <i>EPH 1</i> – input phase detected fault detection • <i>Err 1</i> – speed reference • <i>Err 2</i> – main control board RAM • <i>Err 3</i> – main control board ROM • <i>Err 4</i> – main control board CPU detected fault 1 • <i>Err 5</i> – serial communication control • <i>Err 7</i> – motor current sensor • <i>Err 8</i> – serial communication network • <i>Err 9</i> – graphic display option communication interruption • <i>Et n 1</i> – auto-tuning • <i>EtYP</i> – drive ratings • <i>oCR</i> – short-circuit detected in drive output inverter stage during motor startup • <i>oCL</i> – short-circuit detected in motor or output wiring during motor startup • <i>oH 2</i> - external overheating • <i>ot</i> – overtorque • <i>uc</i> – underload • <i>uP 1</i> - Undervoltage
<p>27 [Inv manu reset flt.] Inversion of Manu reset flt. function</p>	<p>OFF: One (or more) of the following fault conditions exists and has stopped the drive:</p> <ul style="list-style-type: none"> • <i>E</i> – external detected fault • <i>E - 1B</i> – VIA analog input signal • <i>E - 19</i> – main control board CPU communication • <i>E - 20</i> – excessive torque boost • <i>E - 21</i> – main control board CPU detected fault 2 • <i>EEP 1</i> – main control board EEPROM detected fault 1 • <i>EEP 2</i> – main control board EEPROM detected fault 2 • <i>EEP 3</i> – main control board EEPROM detected fault 3 • <i>EF 2</i> – ground fault • <i>EPHD</i> – output phase loss detection • <i>EPH 1</i> – input phase loss detection • <i>Err 1</i> – speed reference • <i>Err 2</i> – main control board RAM • <i>Err 3</i> – main control board ROM • <i>Err 4</i> – main control board CPU detected fault 1 • <i>Err 5</i> – serial communication control • <i>Err 7</i> – motor current sensor • <i>Err 8</i> – serial communication network • <i>Err 9</i> – graphic display option communication interruption • <i>Et n 1</i> – auto-tuning • <i>EtYP</i> – drive ratings • <i>oCR</i> – short-circuit detected in drive output inverter stage during motor startup • <i>oCL</i> – short-circuit detected in motor or output wiring during motor startup • <i>oH 2</i> - external overheating • <i>ot</i> – overtorque • <i>uc</i> – underload • <i>uP 1</i> - Undervoltage <p>ON: None of the detected fault conditions listed above exist</p>

Function No. / Description	Action
<p>28 [Auto-reset fault] Auto-clear detected fault</p> <p>Note: Relay activates when maximum number of autoclear set by [Number auto reset] (<i>F 3 0 3</i>) page 135 is reached.</p>	<p>OFF: None of the detected fault conditions listed below exist ON: One (or more) of the following detected fault conditions exists:</p> <ul style="list-style-type: none"> • <i>F d 1</i> – damper detected fault 1 (closed damper) • <i>F d 2</i> – damper detected fault 2 (opened damper) • <i>o C 1</i> – overcurrent during acceleration • <i>o C 2</i> – overcurrent during deceleration • <i>o C 3</i> – overcurrent during constant speed • <i>o C 1 P</i> – Short circuit or ground detected fault during acceleration • <i>o C 2 P</i> – Short circuit or ground detected fault during deceleration • <i>o C 3 P</i> – Short circuit or ground detected fault during constant speed • <i>o H</i> – drive overheating • <i>o L 1</i> – drive overload • <i>o L 2</i> – motor overload • <i>o P 1</i> – overvoltage during acceleration • <i>o P 2</i> – overvoltage during deceleration • <i>o P 3</i> – overvoltage during constant speed
<p>29 [Inv auto-reset fit] Inversion of Auto-reset fault function</p> <p>Note: Relay deactivates when maximum number of autoclear set by [Number auto reset] (<i>F 3 0 3</i>) page 135 is reached.</p>	<p>OFF: One (or more) of the following detected fault conditions exists:</p> <ul style="list-style-type: none"> • <i>F d 1</i> – damper detected fault 1 (closed damper) • <i>F d 2</i> – damper detected fault 2 (opened damper) • <i>o C 1</i> – overcurrent during acceleration • <i>o C 2</i> – overcurrent during deceleration • <i>o C 3</i> – overcurrent during constant speed • <i>o C 1 P</i> – Short circuit or ground detected fault during acceleration • <i>o C 2 P</i> – Short circuit or ground detected fault during deceleration • <i>o C 3 P</i> – Short circuit or ground detected fault during constant speed • <i>o H</i> – drive overheating • <i>o L 1</i> – drive overload • <i>o L 2</i> – motor overload • <i>o P 1</i> – overvoltage during acceleration • <i>o P 2</i> – overvoltage during deceleration • <i>o P 3</i> – overvoltage during constant speed <p>ON: None of the detected fault conditions listed above exist</p>
<p>30 [Drive rdy 1] drive ready condition 1</p>	<p>OFF: drive not ready for operation ON: drive ready for operation (ready includes active run permissive and active run command)</p>
<p>31 [Inv drive rdy 1] Inversion of Drive rdy 1 function</p>	<p>OFF: drive ready for operation (ready includes active run permissive and active run command) ON: drive not ready for operation</p>
<p>32 [Drive rdy 2] drive ready condition 2</p>	<p>OFF: drive not ready for operation ON: drive ready for operation (ready does not include active run permissive or active run command)</p>
<p>33 [Inv drive rdy 2] Inversion of Drive rdy 2 function</p>	<p>OFF: drive ready for operation (ready does not include active run permissive or active run command) ON: drive not ready for operation</p>
<p>34 [VIB ref source] VIB input reference source</p>	<p>OFF: analog input terminal VIB is NOT the active speed reference source ON: VIB is the active speed reference source</p>
<p>35 [Inv VIB ref source] Inversion of VIB ref source function</p>	<p>OFF: analog input terminal VIB is the active speed reference source ON: VIB is NOT the active speed reference source</p>

Function No. / Description	Action
<p>36 [Fault relay] (The drive is not in a fault state during auto clear detected fault attempts. See also function 10 page 108)</p>	<div style="border: 1px solid black; padding: 5px; text-align: center;">  WARNING </div> <p>LOSS OF CONTROL</p> <ul style="list-style-type: none"> When <i>F 130</i>, <i>F 132</i>, <i>F 137</i> is set to <i>36</i>, the output will be active when the drive will detect a fault. The drive status will not be detected if the wiring is damaged for any reason. Do not select <i>36</i> unless you are sure that your signal will be present in any case. <p>Failure to follow these instructions can result in death, serious injury, or equipment damage.</p> <p>OFF: No drive detected fault ON: drive detected fault. Relay activates when a clearable fault occurs and the drive attempts to re-start. Relay deactivates when drive is restarting.</p>
<p>37 [Inv fault relay] Inversion of Fault relay function 36</p>	<p>OFF: drive detected fault ON: No drive detected fault Relay deactivates when a clearable fault occurs and the drive attempts to restart. Relay activates when drive is restarting.</p>
<p>38 [Ser. data relay FL] Serial communication data</p>	<p>OFF: Serial communication word <i>F A S D</i> bit 0 = 0 ON: Serial communication word <i>F A S D</i> bit 0 = 1</p>
<p>39 [Inv ser. dat rel. FL] Inversion of ser. dat rel. FL function</p>	<p>OFF: Serial communication word <i>F A S D</i> bit 0 = 1 ON: Serial communication word <i>F A S D</i> bit 0 = 0</p>
<p>40 [Ser. data relay RY] Serial communication data</p>	<p>OFF: Serial communication word <i>F A S D</i> bit 1 = 0 ON: Serial communication word <i>F A S D</i> bit 1 = 1</p>
<p>41 [Inv ser. dat rel RY] Inversion of ser. dat rel. RY function</p>	<p>OFF: Serial communication word <i>F A S D</i> bit 1 = 1 ON: Serial communication word <i>F A S D</i> bit 1 = 0</p>
<p>42 [Drive run time al] Drive operational run time alarm (see page 130 for more detail on parameter <i>F 6 2 1</i>).</p>	<p>OFF: Run time is < <i>F 6 2 1</i> time setting ON: Run time is <i>F 6 2 1</i> time setting</p>
<p>43 [Inv. drive run time al] Inversion of Drive run time al function</p>	<p>OFF: Run time is <i>F 6 2 1</i> time setting ON: Run time is < <i>F 6 2 1</i> time setting</p>
<p>44 [Drive serv. alarm] Drive service alarm (see page 144 for more detail on parameter <i>F 6 3 4</i>).</p>	<p>OFF: drive maintenance detected fault not active ON: drive maintenance detected fault active</p>
<p>45 [Inv. drive serv. alarm] Inversion of Drive serv. alarm function</p>	<p>OFF: drive maintenance detected fault active ON: drive maintenance detected fault not active</p>
<p>48 [LI F state] Logic input F state</p>	<p>OFF: Logic input F is not active ON: Logic input F is active</p>
<p>49 [Inv. LI F state] Inversion of LI F state function</p>	<p>OFF: Logic input F is active ON: Logic input F is not active</p>
<p>50 [LI R state] Logic input R state</p>	<p>OFF: Logic input R is not active ON: Logic input R is active</p>
<p>51 [Inv. LI R state] Inversion of LI R state function</p>	<p>OFF: Logic input R is active ON: Logic input R is not active</p>
<p>52 [Speed ref = VIA] Drive speed reference equals VIA signal</p>	<p>OFF: Speed reference from the source identified by [Frequency mode sel] (<i>F Π o d</i>) or the source identified by [Remote spd ref 2] (<i>F 2 0 7</i>) ≠ VIA signal ON: Speed reference from the source identified by <i>F Π o d</i> or the source identified by <i>F 2 0 7</i> = VIA signal</p>
<p>53 [Inv. speed ref = VIA] Inversion of Speed ref = VIA function</p>	<p>OFF: Speed reference from the source identified by [Frequency mode sel] (<i>F Π o d</i>) or the source identified by [Remote spd ref 2] (<i>F 2 0 7</i>) = VIA signal ON: Speed reference from the source identified by <i>F Π o d</i> or the source identified by <i>F 2 0 7</i> ≠ VIA signal</p>

Function No. / Description	Action
54 [Undervolt. alarm] Undervoltage alarm	OFF: Undervoltage detected fault is not active ON: Undervoltage detected fault is active
55 [Inv. undervolt. alarm] Inversion of Undervolt. al. function	OFF: Undervoltage detected fault is active ON: Undervoltage detected fault is not active
56 [Loc / remote] Local/remote switching	OFF: drive is in remote mode ON: drive is in local mode
57 [Inv. loc / remote] Inversion of Loc / remote function	OFF: drive is in local mode ON: drive is in remote mode
58 [PTC alarm] PTC thermal alarm	OFF: Motor temperature as indicated by PTC thermal probes is < 60% of the detected fault level ON: Motor temperature as indicated by PTC thermal probes is 60% of the detected fault level
59 [Inv. PTC alarm] Inversion of PTC alarm function	OFF: Motor temperature as indicated by PTC thermal probes is 60% of the detected fault level ON: Motor temperature as indicated by PTC thermal probes is < 60% of the detected fault level
60 [Speed ref = VIB] Drive speed reference equals VIB signal	OFF: Speed reference from the source identified by [Frequency mode sel] (F P o d) or the source identified [Remote spd ref 2] (F 2 0 7) ≠ VIB signal ON: Speed reference from source identified by F P o d or the source identified F 2 0 7 = VIB signal
61 [Inv. speed ref = VIB] Inversion of Speed ref = VIB function	OFF: Speed reference from source identified by [Frequency mode sel] (F P o d) or the source identified [Remote spd ref 2] (F 2 0 7) = VIB signal ON: Speed reference from the source identified by F P o d or the source identified F 2 0 7 ≠ VIB signal
62 [VIA detection] Analog VIA detection	ON: The value of VIA is equal to or higher than F 1 6 0 + F 1 6 1 OFF: The value of VIA is equal to or lower than F 1 6 0 - F 1 6 1
63 [Inv. VIA detection] Inversion of VIA detection function	ON: The value of VIA is equal to or lower than F 1 6 0 - F 1 6 1 OFF: The value of VIA is equal to or higher than F 1 6 0 + F 1 6 1
64 [VIB detection] Analog VIB detection	ON: The value of VIB is equal to or higher than F 1 6 2 + F 1 6 3 OFF: The value of VIB is equal to or lower than F 1 6 2 - F 1 6 3
65 [Inv. VIB detection] Inversion of VIB detection function	ON: The value of VIB is equal to or lower than F 1 6 2 - F 1 6 3 OFF: The value of VIB is equal to or higher than F 1 6 2 + F 1 6 3
66 [Freq. reach hyst] Set frequency attainment signal with hysteresis	ON: The output frequency is equal to or higher than F 1 0 1 + F 1 0 2 OFF: The output frequency is equal to or lower than F 1 0 1 - F 1 0 2 (See page 125 for more detail on parameters F 1 0 1 and F 1 0 2.)
67 [Inv. freq. reach hyst] Inversion of Freq. reach hyst function	ON: The output frequency is equal to or lower than F 1 0 1 - F 1 0 2 OFF: The output frequency is equal to or higher than F 1 0 1 + F 1 0 2 (See page 125 for more detail on parameters F 1 0 1 and F 1 0 2.)
68 [Damper] Damper control	ON: The damper is ON. OFF: The damper is OFF (see page 127)
69 [Inv. damper] Inversion of Damper function	ON: The damper is OFF. OFF: The damper is ON (see page 127)
70 [DisOil Inj PL] Disable oil injection in high speed positive logic	Positive logic
71 [DisOil Inj NL] Disable oil injection in high speed negative logic	Negative logic
254 [Relay OFF] Relay output is OFF	OFF
255 [Relay ON] Relay output is ON	ON

Analog Input Functions

Two analog inputs are supplied with the ATV212 drive. The terminals are designated VIA and VIB.

Analog Input VIA

- VIA can accept the following signal types:
 - Voltage (V): 0–10 V, voltage or potentiometer input
 - Current (I): 0–20 mA or 4–20 mA

The signal type (V or I) is selected by setting SW100 on the main control board.
For information on wiring, consult the ATV212 Installation manual.
- The slope and bias of the input signal are adjusted with parameters [F 2 0 1–F 2 0 4](#) and [F 4 7 0–F 4 7 1](#). For more information, see page [116](#).
- VIA is configured as the speed reference input in the following macro-configurations:
 - Run permissive
 - 3-wire
 - 4-20 mA.
- Relay output functions 34 and 35 can signal when VIA is being used as the speed reference source. For more information, see table on page [111](#) and consult “I/O Control Parameters” on page [100](#).
- Relay output functions 52 and 53 can be used to signal the results of a comparison between the signal at VIA and the speed reference commanded by [\[Frequency mode sel\] \(F 0 0 d\)](#) or [\[Remote spd ref 2\] \(F 2 0 7\)](#). This function can also be used to send out a signal indicating whether the amount of processing and the amount of feedback agree with each other. For more information, see table on page [108](#). Also, consult “I/O Control Parameters” on page [100](#) and review information about parameter [F 1 6 7](#) on page [126](#).
- The drive can enter a detected fault state if the VIA signal drops below a specified level for more than 300 mS. For more information, see parameter [F 6 3 3](#) on page [141](#) and code [E - 1 8](#) on page [180](#).
- VIA can serve as an analog or a logic input, depending on setting of parameter [F 1 0 9](#) (set to 0 for analog input). Analog input is the factory setting. See page [100](#) for more information about parameter [F 1 0 9](#).

Analog Input VIB

- VIB can accept the following signal types:
 - Voltage (V): 0–10V, voltage or potentiometer input
 - PTC motor thermal sensor input. For more information, see parameters [F 6 4 5](#) and [F 6 4 6](#) on page [122](#).
 - Adjust the slope and bias of the input signal with parameters [F 2 1 0 - F 2 1 3](#) and [F 4 7 2 - F 4 7 3](#). For more information, see page [116](#).
- Relay output functions 52 and 53 can signal when VIA is being used as the speed reference source. For more information, see table on page [112](#) and consult “I/O Control Parameters” on page [100](#).
- Relay output functions 60 and 61 can be used to signal the results of a comparison between the signal at VIB and the speed reference commanded by [\[Frequency mode sel\] \(F 0 0 d\)](#) or [\[Remote spd ref 2\] \(F 2 0 7\)](#). This function can also be used to send out a signal indicating whether the amount of processing and the amount of feedback agree with each other. For more information, see table on page [108](#). Also, consult “I/O Control Parameters” on page [100](#) and review information about parameter [F 1 6 7](#) on page [126](#).

General

- The selection of VIA or VIB as the speed reference input in remote mode is made through parameters [\[Frequency mode sel\] \(F 0 0 d\)](#) and [\[Remote spd ref 2\] \(F 2 0 7\)](#). [F 0 0 d](#) is the primary speed reference source, while [F 2 0 7](#) is the secondary source. Switching between the two is determined by the setting of parameter [\[Auto/man speed ref\] F 2 0 0](#). For more information, see page [118](#).
- Analog output terminal FM can be configured to provide a signal in proportion to the VIA or VIB signal levels. See parameter [F 0 5 L](#), selections 13 and 14, on page [118](#).
- When PID control is enabled, VIA or VIB can serve as the setpoint input. Either VIA or VIB needs to be selected as the feedback input. See page [120](#) for more information on parameter [F 3 6 0](#) and PID control.
- Information can be transferred between the serial communication network and the analog inputs via read and write functions [F 8 7 0](#), [F 8 7 1](#), and [F 8 7 5–F 8 7 9](#). For more information, see pages [150](#) to [151](#).

Analog Output Functions

One analog output is supplied with the ATV212 drive. The terminal is designated FM.

FM is a multifunctional programmable analog output supplying an output frequency signal as the factory default.

The FM terminal can output a voltage or current signal.

- When switch SW101 is set to V (voltage), FM outputs a 0–10 Vdc signal at 1 mA.
- When switch SW101 is set to I (current), FM outputs a 0–20 mA signal up to 24 Vdc. For detail on proper wiring, consult the ATV212 Installation manual.

The drive value represented by the FM analog output signal is determined by the setting of parameter [\[AO funct. selection\] \(F75L\)](#) (see page [118](#)).

Calibrating the FM signal output to provide full scale deflection on an analog meter is achieved by adjusting parameter [\[AO scaling\] \(F7\)](#) (see page [118](#)).

The slope and bias of the FM analog output signal can be adjusted using parameters [F691](#) and [F692](#). For more information, see page [119](#).

Analog Input Adjustments

Analog Input Speed Reference and Output Frequency

Do not set the same frequency values for both output frequency levels 1 and 2. This will cause an *Err 1* detected fault.

When using a 4–20 mA signal, set speed reference level 1 value to 20% ($4 \div 20 = 20\%$).

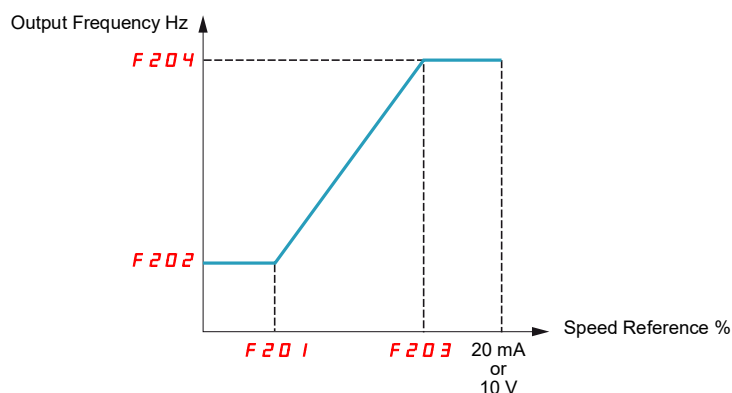

A further refinement of the bias and slope of the analog input signals can be made with parameters $F_{470} - F_{473}$.

Code	Name / Description		Adjustment range	Factory setting
F_{201}	[VIA ref point 1]	VIA speed reference level 1	0 to 100%	0%
F_{202}	[VIA freq. point 1]	VIA output frequency level 1	0.0 to 200.0 Hz	0.0 Hz
F_{203}	[VIA ref point 2]	VIA speed reference level 2	0 to 100%	100%
F_{204}	[VIA freq. point 2]	VIA output frequency level 2	0.0 to 200.0 Hz	50.0 Hz
F_{160}	[VIA rel thresh. logic]	Threshold logic for relay link to VIA	0 to 100%	0%
F_{161}	[VIA threshold hyst.]	Hysteresis threshold for logic relay link to VIA	0 to 20%	3%
F_{210}	[VIB ref. point 1]	VIB speed reference level 1	0 to 100%	0%
F_{211}	[VIB freq. point 1]	VIB output frequency level 1	0.0 to 200.0 Hz	0.0 Hz
F_{212}	[VIB ref. point 2]	VIB speed reference level 2	0 to 100%	100%
F_{213}	[VIB freq. point 2]	VIB output frequency level 2	0.0 to 200.0 Hz	50.0 Hz
F_{162}	[VIB rel thresh. logic]	Threshold logic for relay link to VIB	0 to 100%	0%
F_{163}	[VIB threshold hyst.]	Hysteresis threshold for logic relay link to VIB	0 to 20%	3%

Code	Name / Description	Adjustment range	Factory setting
F 4 7 0	[VIA bias] VIA analog input bias	0 to 255	128
<div style="background-color: black; color: white; padding: 5px; font-weight: bold; font-size: 1.2em;">⚠ DANGER</div> <div style="border: 1px solid black; padding: 5px;"> <p>UNINTENDED EQUIPMENT OPERATION If the input bias level is set too high, the drive will start the motor without a signal present at VIA or VIB. Failure to follow these instructions will result in death or serious injury.</p> </div>			
F 4 7 1	[VIA gain] VIA analog input gain	0 to 255	148
F 4 7 2	[VIB bias] VIB analog input bias	0 to 255	128
<div style="background-color: black; color: white; padding: 5px; font-weight: bold; font-size: 1.2em;">⚠ DANGER</div> <div style="border: 1px solid black; padding: 5px;"> <p>UNINTENDED EQUIPMENT OPERATION If the input bias level is set too high, the drive will start the motor without a signal present at VIA or VIB. Failure to follow these instructions will result in death or serious injury.</p> </div>			
F 4 7 3	[VIB gain] VIB analog input gain	0 to 255	148

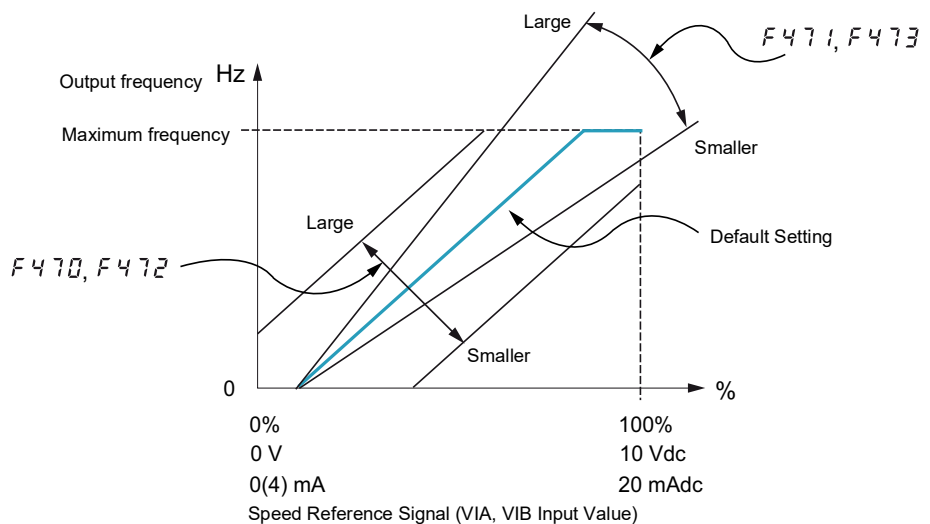

Parameters **[VIA bias]** (F 4 7 0) and **[VIB bias]** (F 4 7 2) are factory set so that a minimal signal needs to be applied to VIA or VIB before the drive starts the motor.

- To increase the signal level required to start the motor, decrease the input bias level.
- To reduce the signal level required to start the motor, increase the input bias level.

⚠ DANGER

UNINTENDED EQUIPMENT OPERATION
 If the input bias level is set too high, the drive will start the motor without a signal present at VIA or VIB.
Failure to follow these instructions will result in death or serious injury.

Parameters **[VIA gain]** (F 4 7 1) and **[VIB gain]** (F 4 7 3) are factory set so that the drive output reaches rated voltage and frequency just before the signal to VIA or VIB reaches its maximum level.

- To decrease the signal level required before the drive output reaches rated voltage and frequency, increase the input gain level.
- To increase the signal level required before the drive output reaches rated voltage and frequency, decrease the input gain level.

Note: If the input gain level is set too low, the drive output may never reach rated voltage and frequency.

Code	Name / Description	Factory setting																																																															
F 2 0 0 0 1	[Auto/man speed ref] Auto/Manual Speed Reference Switching	0																																																															
	<p>[Enable] [Disable]</p> <p>Switching between two speed reference sources by means of a logic input is enabled if parameter F 2 0 0 is set to 0. To use this function, you need to assign a logic input to function 38, Auto/Man speed ref.</p> <p>When the assigned logic input is off, the drive will follow the speed reference source defined by parameter [Frequency mode sel] (F 0 0 d) (see page 87). When the assigned logic input is on, the drive will follow the speed reference source defined by parameter [Remote spd ref 2] (F 2 0 7) (see page 88). When parameter F 2 0 0 is set to 1, the drive will follow the F 0 0 d speed reference source when it is operating above 1 Hz. Below 1 Hz, it will follow the F 2 0 7 speed reference source.</p>																																																																
F 0 5 L	[AO funct. selection] Analog Output Function Selection	0																																																															
	<table border="1"> <thead> <tr> <th>Value</th> <th>Function</th> <th>Maximum Signal</th> </tr> </thead> <tbody> <tr> <td>0</td> <td>[Motor frequency]: Output frequency</td> <td>[Max frequency] (F H)</td> </tr> <tr> <td>1</td> <td>[Motor current]: Output current</td> <td>150 % of [Motor current]</td> </tr> <tr> <td>2</td> <td>[Speed ref]: Speed reference</td> <td>[Max frequency] (F H)</td> </tr> <tr> <td>3</td> <td>[DC bus U]: DC bus voltage</td> <td>150 % of [DC bus U]</td> </tr> <tr> <td>4</td> <td>[Motor U]: Output motor voltage</td> <td>150 % of [Motor U]</td> </tr> <tr> <td>5</td> <td>[Input power]: Input power</td> <td>185 % of [Input power]</td> </tr> <tr> <td>6</td> <td>[Output power]: Output power</td> <td>185 % of [Output power]</td> </tr> <tr> <td>7</td> <td>[motor torque]: Estimated motor torque</td> <td>250 % of rated motor torque</td> </tr> <tr> <td>8</td> <td>[Torque I]: Motor torque current</td> <td>Current at 250 % of rated motor torque</td> </tr> <tr> <td>9</td> <td>[Motor thermal]: Motor thermal state</td> <td>100 % of motor's rating</td> </tr> <tr> <td>10</td> <td>[Drive thermal]: drive thermal state</td> <td>100 %</td> </tr> <tr> <td>11</td> <td>[Do not use]: DO NOT USE</td> <td>-</td> </tr> <tr> <td>12</td> <td>[Internal reference]: Internal speed reference (after PID)</td> <td>[Max frequency] (F H)</td> </tr> <tr> <td>13</td> <td>[VIA]: VIA input value</td> <td>Maximum input value</td> </tr> <tr> <td>14</td> <td>[VIB]: VIB input value</td> <td>Maximum input value</td> </tr> <tr> <td>15</td> <td>[Fixed 100%]: Fixed output – 100% signal (Selection 1 – output current)</td> <td>-</td> </tr> <tr> <td>16</td> <td>[Fixed 50%]: Fixed output – 50% signal (Selection 1 – output current)</td> <td>-</td> </tr> <tr> <td>17</td> <td>[Fixed 100%]: Fixed output – 100% signal (Selections 0, 2, 3, 4, 5, 6, 7, 8, 9,10, 12, 13, 14, 18)</td> <td>-</td> </tr> <tr> <td>18</td> <td>[Com data]: Serial communication data</td> <td>F A 5 I = 1000</td> </tr> <tr> <td>19</td> <td>[Do not use]: DO NOT USE</td> <td>-</td> </tr> </tbody> </table>	Value	Function	Maximum Signal	0	[Motor frequency] : Output frequency	[Max frequency] (F H)	1	[Motor current] : Output current	150 % of [Motor current]	2	[Speed ref] : Speed reference	[Max frequency] (F H)	3	[DC bus U] : DC bus voltage	150 % of [DC bus U]	4	[Motor U] : Output motor voltage	150 % of [Motor U]	5	[Input power] : Input power	185 % of [Input power]	6	[Output power] : Output power	185 % of [Output power]	7	[motor torque] : Estimated motor torque	250 % of rated motor torque	8	[Torque I] : Motor torque current	Current at 250 % of rated motor torque	9	[Motor thermal] : Motor thermal state	100 % of motor's rating	10	[Drive thermal] : drive thermal state	100 %	11	[Do not use] : DO NOT USE	-	12	[Internal reference] : Internal speed reference (after PID)	[Max frequency] (F H)	13	[VIA] : VIA input value	Maximum input value	14	[VIB] : VIB input value	Maximum input value	15	[Fixed 100%] : Fixed output – 100% signal (Selection 1 – output current)	-	16	[Fixed 50%] : Fixed output – 50% signal (Selection 1 – output current)	-	17	[Fixed 100%] : Fixed output – 100% signal (Selections 0, 2, 3, 4, 5, 6, 7, 8, 9,10, 12, 13, 14, 18)	-	18	[Com data] : Serial communication data	F A 5 I = 1000	19	[Do not use] : DO NOT USE	-	
Value	Function	Maximum Signal																																																															
0	[Motor frequency] : Output frequency	[Max frequency] (F H)																																																															
1	[Motor current] : Output current	150 % of [Motor current]																																																															
2	[Speed ref] : Speed reference	[Max frequency] (F H)																																																															
3	[DC bus U] : DC bus voltage	150 % of [DC bus U]																																																															
4	[Motor U] : Output motor voltage	150 % of [Motor U]																																																															
5	[Input power] : Input power	185 % of [Input power]																																																															
6	[Output power] : Output power	185 % of [Output power]																																																															
7	[motor torque] : Estimated motor torque	250 % of rated motor torque																																																															
8	[Torque I] : Motor torque current	Current at 250 % of rated motor torque																																																															
9	[Motor thermal] : Motor thermal state	100 % of motor's rating																																																															
10	[Drive thermal] : drive thermal state	100 %																																																															
11	[Do not use] : DO NOT USE	-																																																															
12	[Internal reference] : Internal speed reference (after PID)	[Max frequency] (F H)																																																															
13	[VIA] : VIA input value	Maximum input value																																																															
14	[VIB] : VIB input value	Maximum input value																																																															
15	[Fixed 100%] : Fixed output – 100% signal (Selection 1 – output current)	-																																																															
16	[Fixed 50%] : Fixed output – 50% signal (Selection 1 – output current)	-																																																															
17	[Fixed 100%] : Fixed output – 100% signal (Selections 0, 2, 3, 4, 5, 6, 7, 8, 9,10, 12, 13, 14, 18)	-																																																															
18	[Com data] : Serial communication data	F A 5 I = 1000																																																															
19	[Do not use] : DO NOT USE	-																																																															
F 0	[AO scaling] Analog Output Scaling	-																																																															
	<p>Parameter F 0 is used to match the FM terminal output signal with the input requirements of the attached panel meter by adjusting the slope and bias of the analog output signal. Before adjusting F 0, set [AO funct. selection] (F 0 5 L) to either 15 or 17. As you adjust the value of F 0, monitor the display on the attached panel meter. When the meter display reaches 100%, press the ENT key on the drive embedded display terminal. The drive will flash between F 0 and the adjusted value, indicating that the adjustment has been saved.</p>																																																																

Code	Name / Description	Adjustment range	Factory setting
F 691 0 1	[AO slope] Analog Output Slope [Negative slope] [Positive slope]	-	1
F 692	[Analog output bias] Refer to the diagram below for examples of adjusting parameters [AO scaling] (F 7), [AO slope] (F 691), and F 692.	0 to 100%	0%
<div style="display: flex; flex-wrap: wrap; justify-content: space-around;"> <div style="text-align: center; margin: 5px;"> <p>F 691=1, F 692=0</p> </div> <div style="text-align: center; margin: 5px;"> <p>F 691=1, F 692=20</p> </div> <div style="text-align: center; margin: 5px;"> <p>F 691=0, F 692=100</p> </div> <div style="text-align: center; margin: 5px;"> <p>F 691=0, F 692=100</p> </div> </div>			
F 694	[Freq. for AO = 0V] Low frequency when analog output equal 0 V	0 Hz to [Max frequency] (F H)	0 Hz
<p>Refer to the diagram below for adjusting parameters F 694, and [Freq. for AO = 10V] (F 695).</p> <div style="display: flex; justify-content: space-around;"> <div style="text-align: center;"> <p>Speed reference Motor frequency Internal reference (after PID)</p> </div> <div style="text-align: center;"> <p>Speed reference Motor frequency Internal reference (after PID)</p> </div> </div>			
F 695	[Freq. for AO = 10V] High frequency when analog output equal 10 V	0 Hz to [Max frequency] (F H)	0 Hz
<p>Refer to the diagram above for adjusting parameters [Freq. for AO = 0V] (F 694), and F 695.</p>			
F 130	[RY Relay Function 1] RYA-RYC Relay Function If [Driving Scroll] (F324) page 160 is set to [yes] (1) the setting is replaced by [disable oil injection in high speed positive logic] (70) For a complete description of the various functions assignable to the RYA-RYC relay, see page 108. The RYA-RYC relay can have a secondary assignment with programmed selection logic. See parameters [RY Relay Function 2] (F 137) and [RY logic select.] (F 139) on page 124 for more detail.	0 to 69, 254, 255	4
F 146	[RY delay] Delay for RYA-RYC Relay This parameter introduce a delay on RYA-RYC output signal relay.	0.0 to 60.0 s	0.0 s

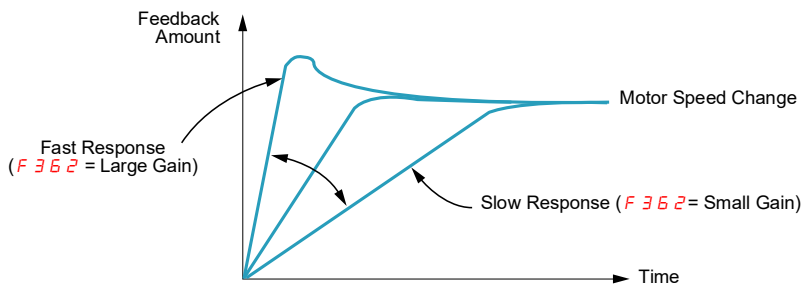
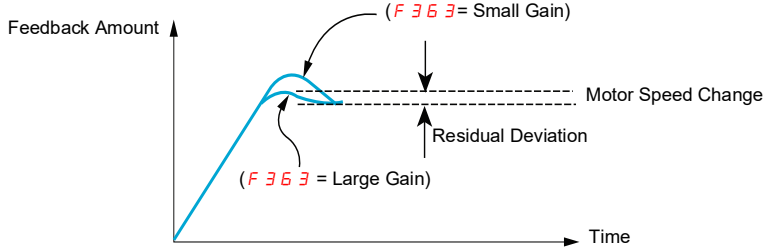
Code	Name / Description	Adjustment range	Factory setting
F 132	[FL Relay Function] Function for FL Relay If [Driving Scroll] (F324) page 160 is set to [yes] (1) the setting is replaced by [Inv F101 sp reach] (9) For a complete description of the various functions assignable to the FL relay, see page 108 .	0 to 69, 254, 255	11
F 147	[FL Relay delay] Delay for FL Relay This parameter introduce a delay on FL output signal relay.	0.0 to 60.0 s	0.0 s
F 360	[PID control enable] 0 [No PID]: PID disabled 1 [PID by VIA]: Enabled (feedback source is VIA) 2 [PID by VIB]: Enabled (feedback source is VIB) Parameter F 360 is used to enable PID control and define the source of the feedback signal. The PID source is defined by the setting of parameter [Frequency mode sel] (F P o d) (see page 87). Parameter [Freq band det range] (F 15 7) can be adjusted to command a drive relay to signal when the PID setpoint and feedback are in agreement (see page 126).	-	0
F 362	[PID Prop Gain] PID Proportional Gain Parameter F 362 adjusts the proportional gain applied during PID control. The speed change applied to the motor is a correctional value proportional to the product of this parameter's setting and the process error (deviation between the setpoint and the feedback value). A higher setting of F 362 provides a fast response to a process error but may also result in instability such as hunting. The diagram below illustrates the effect produced by adjusting F 362 .	0.01 to 100.0%	0.30%
			
F 363	[PID Integral Gain] Parameter F 363 adjusts the integral gain applied during PID control. Any residual process errors that remain after correction by the proportional gain are cleared to zero over time by the integral gain function. A higher setting of F 363 provides a fast response to a process error but may also result in instability such as hunting. The diagram below illustrates the effect produced by adjusting F 363 .	0.01 to 100.0	0.20
			
	The integral gain value can be set to zero by setting a logic input to function 65. For more information, see table on page 101 and parameters [LI F selection] (F 1 1 1) , [LI R selection] (F 1 1 2) , [LI RES selection] (F 1 1 3) , page 100 , and [VIA LI selection] (F 1 1 B) , page 100 .		

Code	Name / Description	Adjustment range	Factory setting
F 366	[PID Derivative Gain] Parameter F 366 adjusts the derivative gain applied during PID control. This gain adjusts the response time of the drive to rapid changes in the process. Increasing the setting of F 366 more than necessary may cause great fluctuations in motor speed resulting in system instability. The diagram below illustrates the effect produced by adjusting F 366 .	0.00 to 2.55	0.00
F 359	[PID ctrl wait time] PID Control Waiting Time	0 to 2400 s	0
	<p>If parameter F 359 is set to a value greater than 0 seconds, the drive will not immediately enter PID control upon startup. For the time set by F 359, the drive will ignore the feedback signal, accelerating the motor to the speed set by the reference input. This function can be used to help prevent the drive from entering PID control mode before the system approaches the final operating level.</p>		
F 380	[PID reverse error] PI regulator reversal direction correction		0
0 1	[No] [Yes]		
	<p>This function is used to reverse the error PI for Water Pump. If F 380 = 0 or No, PI error input = reference - feedback. The motor speed increases when the error is positive. If F 380 = 1 or Yes, PI error input = feedback - reference. The motor speed decreases when the error is positive.</p>		
F 256	[Time limit low spd]	0.0 to 600 s	0.0 s
0 1	[Disable]: (0.0) [Enable]: (0.01 to 600 seconds)		
	<p>If parameter F 256 is enabled and if the drive operates continuously at [Low limit frequency] (LL) (see page 92) for a time period equal to the setting of F 256, the drive will ramp the motor to a stop. While the motor is stopped, "L S t P" will flash on the drive embedded display terminal.</p> <p>When the speed reference to the drive exceeds the low speed level LL + F 391, the drive will accelerate the motor to the new speed reference.</p> <p>If parameter F 256 is enabled, drive operation at or below the low speed level is also monitored during startup or during reversing of the motor. See diagram below.</p>		

Code	Name / Description	Adjustment range	Factory setting
F 3 9 1	[Stop on LL hyst] Stop on LL hysteresis Activated if [Time limit low spd] (F 2 5 5) is not set to [Disable] (0)	0.0 to [Max frequency] (F H)	0.2 Hz
F 3 9 2	[PID wake up (thres)] PI wake up threshold on PI error Activated if [Time limit low spd] (F 2 5 5) is not set to [Disable] (0)	0.0 to [Max frequency] (F H)	0.0 Hz
⚠ DANGER			
UNINTENDED EQUIPMENT OPERATION Check that unintended restarts will not endanger personnel or equipment in any way. Failure to follow these instructions will result in death or serious injury.			
F 3 9 3	[PID wake up, feedb] PI wake up threshold on PI feedback error Activated if [Time limit low spd] (F 2 5 5) is not set to [Disable] (0)	0.0 to [Max frequency] (F H)	0.0 Hz
⚠ DANGER			
UNINTENDED EQUIPMENT OPERATION Check that unintended restarts will not endanger personnel or equipment in any way. Failure to follow these instructions will result in death or serious injury.			
F 6 4 5	[Mot PTC selection] PTC Motor Thermal Protection Enable 0 [Disabled] 1 [Enabled fault] (detected fault mode). If F 6 4 5 is set to 1 and the PTC probe exceeds a given, threshold, the drive will trip and display an [PTC overheating] (o H 2) code. 2 [Enabled alarm] (alarm mode). If F 6 4 5 is set to 2 and the PTC probe exceeds a given, threshold, the drive will signal a detected fault and continue operating. Setting parameter F 6 4 5 to 1 or 2 converts control terminal VIB into a PTC motor thermal probe input. See the ATV212 Installation manual, for wiring details.	-	0
F 6 4 6	[PTC resistor value]	100 to 9999 Ω	3000 Ω

Active Logic Function

Two logic input functions can be configured to be active. The logic input functions assigned to parameters **[Logic Funct 1 active]** (**F 1 0 8**) and **[Logic Funct 2 active]** (**F 1 1 0**) will continuously affect drive operation. See table beginning on page [101](#) for a list of available logic input functions.

Code	Name / Description	Adjustment range	Factory setting
F 1 0 8	[Logic Funct 1 active] Active Logic Function 1	0 to 73	0
F 1 1 0	[Logic Funct 2 active] Active Logic Function 2	0 to 73	1

If **F 1 1 0** is not set to 1 (logic function **[Run permissive]**), a logic input should be assigned to the **[Run permissive]** logic function to enable the motor to start.

Preset Speeds

A maximum of seven preset speeds can be selected by 4 logic inputs (F, R, RES, or VIA). Preset speed control is only active when the drive is in logic input control ([Command mode sel] (CMOd) = 0).

For one preset speed, assign a logic input to function 6.

For up to three preset speeds, use two logic inputs for functions 6 and 7.

For up to seven preset speeds, use three logic inputs for functions 6, 7, and 8.

Preset speed commands take priority over speed commands from any other source. For more information on preset speeds, see page [101](#). See page [46](#), for wiring instructions and timing diagram.

Code	Name / Description	Adjustment range	Factory setting
<i>Sr 1</i>	[Preset speed 1]	<i>LL</i> to <i>UL</i> Hz	15 Hz
<i>Sr 2</i>	[Preset speed 2]	<i>LL</i> to <i>UL</i> Hz	20 Hz
<i>Sr 3</i>	[Preset speed 3]	<i>LL</i> to <i>UL</i> Hz	25 Hz
<i>Sr 4</i>	[Preset speed 4]	<i>LL</i> to <i>UL</i> Hz	30 Hz
<i>Sr 5</i>	[Preset speed 5]	<i>LL</i> to <i>UL</i> Hz	35 Hz
<i>Sr 6</i>	[Preset speed 6]	<i>LL</i> to <i>UL</i> Hz	40 Hz
<i>Sr 7</i>	[Preset speed 7]	<i>LL</i> to <i>UL</i> Hz	45 Hz

+/- Speed Control Parameters

+/- speed (motorized potentiometer) control is selected by setting parameter **[Frequency mode sel]** (*F 1 0 d*) or **[Remote spd ref 2]** (*F 2 0 7*) to 5 (see pages 87 and 88). Two logic inputs are required, one to increase the speed command (logic input function 41) and one to decrease the speed command (logic input function 42). Logic input function 43 clears the speed reference value accumulated by the +/- speed logic inputs.

Parameters *F 2 6 4* – *F 2 6 9* refine the operation of +/- speed control.

The ratio of parameter *F 2 6 5* to parameter *F 2 6 4* determines the (+) speed command slope:

$$(+)\text{ speed command slope} = F\ 2\ 6\ 5 / F\ 2\ 6\ 4$$

The ratio of parameter *F 2 6 7* to parameter *F 2 6 6* determines the (-) speed command slope.

$$(-)\text{ speed command slope} = F\ 2\ 6\ 7 / F\ 2\ 6\ 6$$

For more detail, see page 104.

Code	Name / Description	Adjustment range	Factory setting
<i>F 2 6 4</i>	[+speed LI resp time] +Speed Logic Input Response Time Parameter <i>F 2 6 4</i> sets the maximum on-time of the logic input assigned to (+) speed, limiting the speed increase, as defined by parameter [+speed freq. step] (<i>F 2 6 5</i>), to only one step. Keeping the logic input active longer than the time set by parameter <i>F 2 6 4</i> will allow multiple step increases of the speed command.	0.0 to 10.0 s	0.1 s
<i>F 2 6 5</i>	[+speed freq. step] +Speed Frequency Steps Parameter <i>F 2 6 5</i> sets the frequency width in Hz of each (+) speed command step.	0.0 to [Max frequency] (<i>F H</i>) Hz	0.1 Hz
<i>F 2 6 6</i>	[- speed LI resp time] -Speed Logic Input Response Time Parameter <i>F 2 6 6</i> sets the maximum on-time of the logic input assigned to (-) speed, limiting the speed decrease, as defined by parameter [-speed freq. step] (<i>F 2 6 7</i>), to only one step. Keeping the logic input active longer than the time set by parameter [+speed freq. step] (<i>F 2 6 5</i>) will allow multiple step decreases of the speed command.	0.0 to 10.0 s	0.1 s
<i>F 2 6 7</i>	[- speed freq. step] -Speed Frequency Steps Parameter <i>F 2 6 7</i> sets the frequency width in Hz of each (-) speed command step.	0.0 to [Max frequency] (<i>F H</i>) Hz	0.1 Hz
<i>F 2 6 8</i>	[Init +/- Speed] Initial +/- Speed Command Parameter <i>F 2 6 8</i> sets the +/- speed command in Hz that is applied to the drive when it is first powered up. Leaving this parameter at its default value will result in the drive's output frequency starting at 0 Hz every time it is powered up.	0.0 to [Max frequency] (<i>F H</i>) Hz	0.0 Hz
<i>F 2 6 9</i> 0 1	[Init +/- Speed memo] Change of Initial +/- Speed Frequency [Disable] [Enable] The setting parameter <i>F 2 6 9</i> determines whether the value of parameter [Init +/- Speed] (<i>F 2 6 8</i>) will change every time power is cycled to the drive. If parameter <i>F 2 6 9</i> is set to 1, parameter <i>F 2 6 8</i> will be set to the last speed command received by the drive before power was removed.	-	1
<i>F 1 3 7</i>	[RY Relay Function 2] RYA-RYC Relay Secondary Function The RYA-RYC relay can be set to signal a secondary condition. The primary RYA-RYC relay function is set by parameter [RY Relay Function 1] (<i>F 1 3 0</i>) (see page 119). See table beginning on page 108 for a complete description of the primary and secondary functions that can be assigned to the RYA-RYC relay.	0 to 61, 254, 255	255
<i>F 1 3 9</i> 0 1	[RY logic select.] RYA-RYC Relay Function Logic Selection [Function 1and 2]: [RY Relay Function 1] (<i>F 1 3 0</i>) (primary) and [RY Relay Function 2] (<i>F 1 3 7</i>) (secondary) [Function 1 or 2]: <i>F 1 3 0</i> (primary) or <i>F 1 3 7</i> (secondary) The RYA-RYC relay can be configured to energize when either: Both the primary AND secondary conditions are met (true) (<i>F 1 3 9</i> = 0), or Only one OR the other is met (true) (<i>F 1 3 9</i> = 1)	-	0

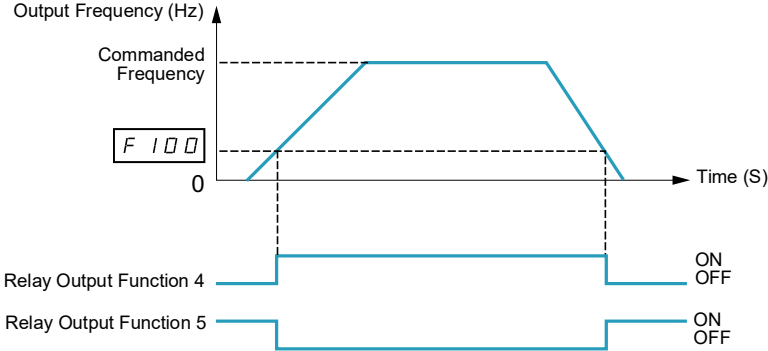
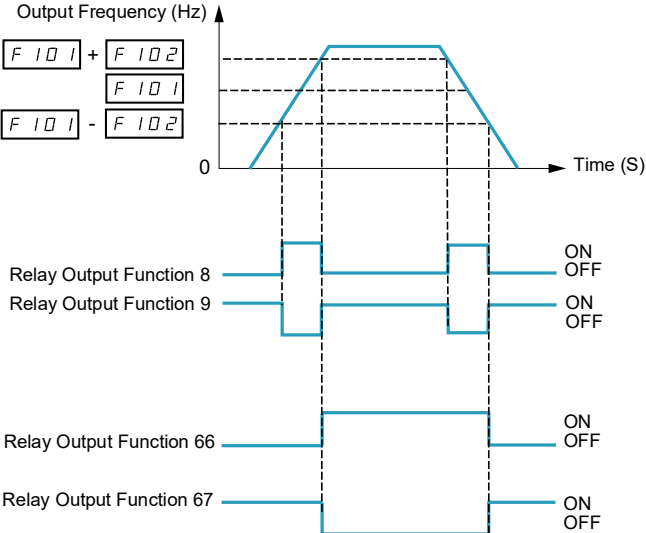
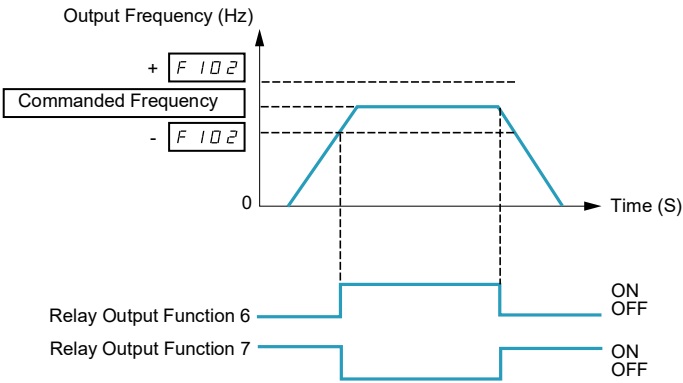
Code	Name / Description	Adjustment range	Factory setting
<p>F 100</p>	<p>[Freq. 1 reached] Relay Output – Frequency Level 1 Attained</p> <p>The frequency set by parameter F 100 is the threshold level for relay output functions 4 and 5 (see page 108).</p> 	0.0 to [Max frequency] (F H) Hz	0.0 Hz
<p>F 101</p>	<p>[Freq. 2 reached] Relay Output – Frequency Level 2 Attained</p> <p>If [Driving Scroll] (F324) page 160 is set to [yes] (1) the setting is replaced by 65 Hz.</p> <p>The frequency set by parameter F 101 +/- the [Freq.2 bandw.] (F 102) detection band is the threshold level for relay output functions 8 and 9 and the hysteresis for relay output functions 66 and 67 (see page 113).</p> 	0.0 to [Max frequency] (F H) Hz	0.0 Hz
<p>F 102</p>	<p>[Freq.2 bandw.] Frequency Attained Detection Band</p> <p>If [Driving Scroll] (F324) page 160 is set to [yes] (1) the setting is replaced by 0.65 Hz.</p> <p>Parameter F 102 determines the bandwidth around the [Freq.2 reached] (F 101) frequency (see diagram above) and the commanded frequency (see diagram below) driving relay output functions 6 through 9 (see page 108).</p> 	0.0 to [Max frequency] (F H) Hz	2.5 Hz

Code	Name / Description	Adjustment range	Factory setting
F 157	[Freq band det range] Frequency bandwidth detection range Parameter F 157 determines the bandwidth around the VIA or VIB speed reference (see below) driving relay output functions 52, 53, 60, and 61 (see page 112). This function can be used to signal whether the amount of processing and the amount of feedback agree when the PID function is in use.	0.0 to [Max frequency] (F H) Hz	2.5 Hz
F 603	[Ext. fault stop Mode] External detected fault stop mode 0 [Freewheel]: Freewheel stop 1 [Ramp stop] 2 [DC braking]: DC injection braking The setting of parameter F 603 determines how the drive will stop if a logic input assigned to function 11 or 46 is activated (see table on pages 101 and 104).	-	0
F 604	[DC brk time ext flt] External Fault DC braking time If parameter [Ext. fault stop Mode] (F 603) is set to 2, parameter F 604 will determine how long DC current will be injected into the motor while the external fault logic input is active.	0.0 to 20.0 s	1.0 s

Damper control

This function applies to the ventilation ducts. The aim is to control the opening of the duct (shutter device called a "damper") when the fan starts up.

Damper opening command

The opening command can be assigned to a relay via the *F 130* or *F 132* parameters to the function [Damper] 68 or [Inv. damper] 69 page 113. The damper is closed automatically when there is no longer an opening command.

Damper opening feedback

Opening is controlled by a bit or a logic input that can be assigned via the *F 111* or *F 112* or *F 113* parameters to the function [Damper feedBack] 73 page 106. The corresponding logic input or bit can be configured via the parameter [Damper fdb type] *F 580*.

When there is an inconsistency, the drive goes on a [Damper fault 1] *F d 1* if the damper does not open and on a [Damper fault 2] *F d 2* if it does not close.

The parameter [Time open damper] *F 581* can be used to delay tripping on an opening fault when a run command is sent and the parameter [Time close damper] *F 582* delays the closing fault when a stop command is sent.

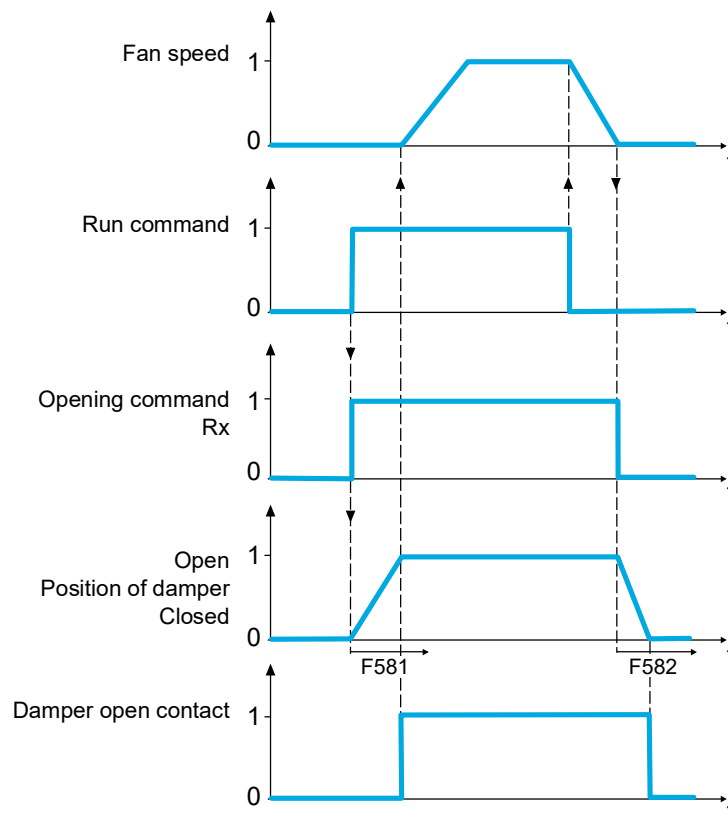
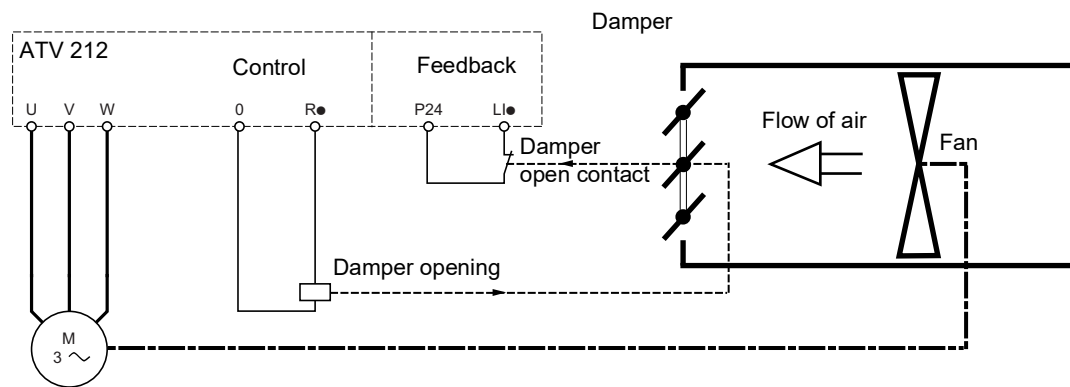

Code	Name / Description	Adjustment range	Factory setting
F 5 B 0	[Damper fdb type]		0
0	[No feedback]: No feedback used (Default value)		
1	[LI L set]: Logical input and active at level 0 (shunt). When setting F 5 B 0 to 1 , first assign logic inputs.		
2	[LIH set]: Logical input and active at level 1 (open). When setting F 5 B 0 to 2 , first assign logic inputs.		
3	[Com. LIL set]: Serial link to communication bit selected by [Com channel choice] (F B 0 7) and active at level 0 (shunt). Please refer to communication manual.		
4	[Com. LIH set]: Serial link to communication bit selected by F B 0 7 and active at level 1 (open). Please refer to communication manual.		
	Setting of F 5 B 0 parameter is independent of the type of command mode. The F B 0 7 parameter allows selecting the communication channel used for communication damper feedback		
F 5 B 1	[Time open Damper]	0.05 s to 300.00 s	60.00
	Opening fault monitoring time delay. If the damper is not open at the end of the set time, the drive will lock in [Damper fault 1] F d 1 detected fault mode. The timer is launch after the run command. The time delay needs to be greater than the normal opening time of the damper.		
F 5 B 2	[Time close Damper]	0.05 s to 300.00 s	60.00
	Closing fault monitoring time delay. If the damper is not close at the end of the set time, the drive will lock in [Damper fault 2] F d 2 detected fault mode. The timer is launch when the motor is stopped. The time delay needs to be greater that the normal closing time of the damper		
F 5 B 3	[Damper flt behavior]		1
0	[No fault]		
1	[Freewheel stop]		
2	[Ramp stop]		
	The F 5 B 3 parameter allows defining the behavior when [Damper fault 1] (F d 1) occurs.		

Display Parameters

9

What's in this Chapter?

This chapter contains the following topics:

Topic	Page
Display parameters	130

Display parameters

Code	Name / Description	Adjustment range	Factory setting
F710	[Displayed param.] Default graphic display option operational value	0 to 10	0
0	[Motor frequency] Motor operating frequency (Hz or custom display), see [Customized freq val] (F702) on page 131.		
1	[Reference] Speed reference (Hz or custom display), see F702 on page 131.		
2	[I Mot] Motor current (% or A), see [Unit value selection] (F701) below.		
3	[Drive rated I] Drive rated current (A)		
4	[Drive therm state] (%)		
5	[Motor power] Output power (kW)		
6	[Int speed ref] Internal speed reference (after PID function) (Hz or custom display, see F702 on page 131).		
7	[Com data] Serial communication data		
8	[Motor speed] Output speed (rpm, see [Motor rated speed] (F417) on page 74)		
9	[Com count] Displays the total number of frames received by the communication card since the last power ON		
10	[Com count norm st.] Displays the total number of valid frames received by the communication card since the last power ON The setting of parameter [Displayed param.] (F710) determines the default display on the drive's embedded display terminal upon power up. Status alarms C, P, L, and H can only be displayed on the graphic display option if [Displayed param.] (F710) is set to 0. See "Run Mode" on page 23 for more information.		
F701	[Unit value selection] Unit value selection	-	1
0	[%]		
1	[Amp or Volt]		
	The setting of parameter F701 determines how certain values will be displayed on the drive embedded display terminal, either as a percentage of the drive rating or as a value of amperes or volts as appropriate. The setting of F701 will only affect parameters and display values that can be represented in amperes or volts. This includes the following parameters: [Motor thermal prot.] (tHr) and F173: motor rated current F251: DC braking current level F185 and F601: motor current limit F611: underload detection level Motor rated voltage (parameters ulu and F171) are displayed in volts.		
F708	[Display ref. resol.] graphic display option Frequency Resolution	-	0
0	Disabled - 0.1 Hz steps		
1 to 255	See the formula below Parameter F708 works along with parameter [Loc. speed ref. step] (F707) (see page 87) to adjust the incremental steps of the drive embedded display terminal frequency display. At its factory setting, parameter F708 is disabled and the embedded display terminal increments or decrements frequency displays in 0.1 Hz steps. If parameter F708 is set to a value other than 0, then the embedded display terminal frequency display is determined as follows: embedded display terminal frequency display = Internal speed reference (after PID function) x F708 / F707 For example, if both F707 and F708 are equal to 1, the embedded display terminal frequency display will increase only in 1 Hz steps.		
F621	[Run time alarm]	0.0 to 999.9	610.0 (6100 hours)
	Parameter F621 is used in conjunction with a relay output set to functions 42 or 43 (see page 112) to signal that the run time specified by the setting of F621 has accumulated. 0.1 = 1 hour, 100 = 1000 hours		
F748	[Power cons. memo] Accumulated power consumption memory	-	1
0	[Disable]		
1	[Enable]		
	The setting of parameter F748 determines whether the drive's accumulated power consumption memory, displayed in kilowatt-hours (kWh), is cleared when the line power is cycled. If F748 is set to 0, the memory is cleared. If set to 1, the kWh memory is retained.		

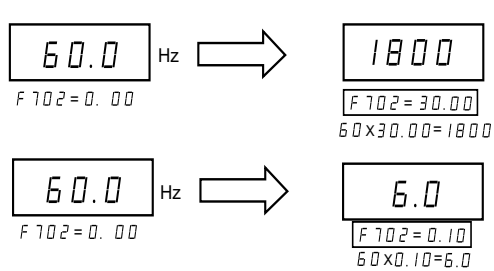
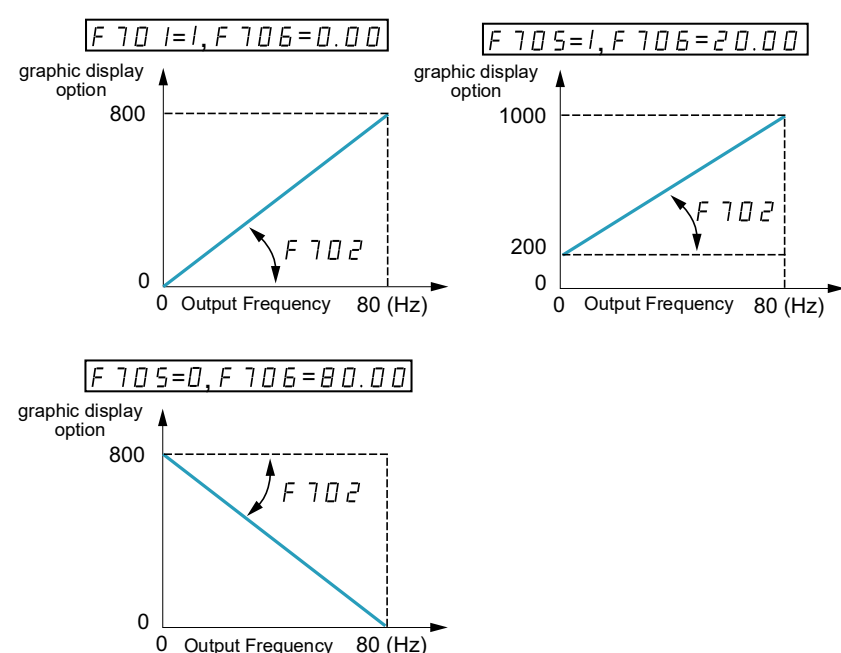
Code	Name / Description	Adjustment range	Factory setting
F749	[Power cons. unit] 0 [1 kWh] 1 [0.1 = 1 kWh] 2 [0.01 = 1 kWh] 3 [0.001 = 1 kWh] The setting of parameter F749 determines the scaling of the kWh display on the embedded display terminal.	-	According to drive rating (1)
F702	[Customized freq val] Customized freq val Parameters F702 , F705 , and F706 can be used to customize a speed display on the drive embedded display terminal to match the application's operational speed, for example, feet per minute or units per hour. 0.00: Frequency displayed in Hz 0.0 If parameter F702 is set to a value other than 0.00, the frequency value displayed will be calculated as follows: Value displayed = display or parameter frequency x F702 . See example below. 1 to 200.0: Conversion factor	0.00 to 200.00	0.00
			
F703	[Frequency convert.] Frequency free unit conversion selection 0 [All] Frequencies display free unit 1 [PID only] PID frequencies free unit conversion		0
F705	[Custom freq. slope] Custom Frequency Display Conversion Slope 0 [Negative slope] 1 [Positive slope] Parameter F705 sets the slope of the custom frequency display conversion. See the diagrams below for examples of the operation of this function.	-	1
F706	[Customize unit bias] Custom Frequency Display Conversion Bias Parameter F706 adds a bias to the custom frequency display conversion process.	0.00 to FH Hz	0.00 Hz
			

(1) See table page 199.

Detected Fault Management Parameters

10

What's in this Chapter?

This chapter contains the following topics:

Topic	Page
Time delay	136
Catch On The Fly (F301)	137
Overtorque Detection	143
Nuisance Overvoltage And Input Phase Detected Fault Avoidance	144
Motor Overload Characteristics	145

F 400	[Auto-tuning drive]	-	0
⚠ ⚠ DANGER			
HAZARD OF ELECTRIC SHOCK OR ARC FLASH			
<ul style="list-style-type: none"> • During auto-tuning, the motor operates at rated current. • Do not service the motor during auto-tuning. <p>Failure to follow these instructions will result in death or serious injury.</p>			
⚠ WARNING			
LOSS OF CONTROL			
<ul style="list-style-type: none"> • It is essential that the following parameters u L u, u L, F 415 and F 417 are correctly configured before starting auto-tuning. • When one or more of these parameters have been changed after auto-tuning has been performed, F 400 will return 0 and the procedure will have to be repeated. <p>Failure to follow these instructions can result in death or serious injury.</p>			
NOTICE			
RISK OF DAMAGE TO THE MOTOR			
<ul style="list-style-type: none"> • Conduct auto-tuning only after the motor has been connected and operation completely stopped. • If auto-tuning is conducted immediately after operation stops, the presence of a residual voltage may result in abnormal tuning. <p>Failure to follow these instructions can result in equipment damage.</p>			
Auto tuning enable			
0	[Disabled]		
1	[Initialize constant]:	Factory setting of [Auto Torque Boost] (F 402) for asynchronous motor. Factory setting of [Auto Torque Boost] (F 402), [Autotune L q-axis] (F 912), and [Autotune L q-axis] (F 913), and [Motor Rated Voltage] (vlv) for synchronous motor.	
2	[Tun Dyn. 1]:	Tune Dynamic, with driving run after the tuning. Application settings of [Auto Torque Boost] (F 402) for asynchronous motor. Application settings of [Auto Torque Boost] (F 402), [Autotune L q-axis] (F 912), and [Autotune L q-axis] (F 913) for synchronous motor.	
3	[Tun Dyn. 2]:	Complete tune Dynamic, with driving run after the tuning. Application settings of [Auto Torque Boost] (F 402), [Autotune L q-axis] (F 912), [Autotune L q-axis] (F 913), and [Motor Rated Voltage] (vlv) for synchronous motor.	
4	[Tun Static 1]:	Tune Static, without driving run after the tuning. Application settings of [Auto Torque Boost] (F 402) for asynchronous motor. Application settings of [Auto Torque Boost] (F 402), [Autotune L q-axis] (F 912), and [Autotune L q-axis] (F 913) for synchronous motor.	
5	[Tun Static 2]:	Complete tune Static, without driving run after the tuning. Application settings of [Auto Torque Boost] (F 402), [Autotune L q-axis] (F 912), and [Autotune L q-axis] (F 913), and [Motor Rated Voltage] (vlv) for synchronous motor.	
Parameter F 400 is reset to "0" after the auto tuning is performed.			

Code	Name / Description	Factory setting
F 303	[Number auto reset]	0
<div style="background-color: black; color: white; padding: 5px; font-weight: bold; font-size: 1.2em;">⚠ DANGER</div> <p>UNINTENDED EQUIPMENT OPERATION</p> <ul style="list-style-type: none"> • The automatic restart can only be used on machines or installations which do not pose any danger to either personnel or equipment. • If the automatic restart is activated, the fault relay will only indicate a fault has been detected once the time-out period for the restart sequence has expired. • The equipment must be used in compliance with national and regional safety regulations <p>Failure to follow these instructions will result in death or serious injury.</p>		
<p>0 Disabled.</p> <p>1 to 10 Number of clear attempts.</p>		

Description

The table below lists the detected faults that can be cleared with Auto clear. If parameter **F 303** is set to a value greater than 0 and one of these detected faults occurs, the drive will attempt to automatically clear the detected fault, allowing it to be re-started:

Fault detection codes that can be cleared with the automatic restart function after the cause has disappeared

Code	Description	Code	Description
E P L F	External Process Threshold error detected	o H	Drive overheating
F d 1	Damper detected fault 1 (closed damper)	o H 2	External overheating
		o L 1	Drive overload
o C 1	Overcurrent during acceleration	o L 2	Motor overload
o C 2	Overcurrent during deceleration	o P 1	Overvoltage during acceleration
o C 3	Overcurrent during constant speed	o P 2	Overvoltage during deceleration
o C 1 P	Short-circuit or ground detected fault during acceleration	o P 3	Overvoltage during constant state operation
o C 2 P	Short-circuit or ground detected fault during deceleration	P S r F	Prestart Speed not reached error detected
o C 3 P	Short-circuit or ground detected fault during constant speed operation	S o u t	Permanent magnet motor step-out

Auto clear attempts will continue until the number of attempts set by parameter **F 303** has been exhausted. If these attempts do not clear the detected fault condition, the drive will stop and a manual clear will be required. If another type of detected fault occurs during the auto clear process, the drive will stop and a manual clear will be required.

A successful auto clear means that the drive accelerates the motor to the commanded speed without another detected fault occurring.

If an unspecified period of time elapses after a successful auto clear attempt without another detected fault occurring, the reset attempt counter will clear allowing another full set of reset attempts to be made during a future detected fault occurrence.

During the auto clear process, the drive embedded display terminal alternately displays **r t r y** and the display value selected by parameter [\[Displayed param.\] \(F 710\)](#), page [130](#).

Conditions permitting auto clear

An auto clear attempt will not be made if the cause of the detected fault persists.

In the case of an **o L 1** or **o L 2** overload detected fault, the drive will calculate the cooling time necessary to clear the detected fault.

In the event of an **o H** detected fault, the heatsink temperature probe will indicate when the detected fault can be cleared.

DC bus voltage measurements will indicate when an **o P 1**, **o P 2**, or **o P 3** detected fault can be cleared.

Time delay

The first clear is attempted 1 second after the detected fault occurs. Each subsequent clear attempt adds 1 second to the time interval, as illustrated in the table below.

Clear detected fault attempts

Attempt number	Time delay between detected fault reset attempt and most recent fault
1	1 second
2	2 seconds
3	3 seconds
4	4 seconds
5	5 seconds
6	6 seconds
7	7 seconds
8	8 seconds
9	9 seconds
10	10 seconds

Fault relay action

An output relay set to functions 10 and 11 (see table on page [108](#)) will not indicate a detected fault until all clear attempts have been exhausted.

Output relay functions 28 and 29 can be used to indicate that an auto-resettable detected fault has occurred.

Output relay functions 36 and 37 can be used to signal any kind of drive detected fault, even during auto clear attempts.

Drive fault memory

If parameter [\[Drive fault memory\]](#) (`F 5 0 2`) is set to 1 and power to the drive is cycled while an auto-resettable detected fault is active, the auto clear action will be cancelled (see page [138](#)).

Catch On The Fly (*F 30 1*)

If catch-on-the-fly motor starting is enabled (parameter *F 30 1* is not set to 0), the drive will detect the motor's rotating direction and speed before applying power. This will result in a smooth reapplication of power to a coasting motor without high current or torque pulses.

If *F 30 1* is disabled and the drive is started into a spinning motor, it will apply a low starting frequency to the motor, operating in current limit until the motor almost stops. Then, the drive will accelerate the motor to the commanded speed.

Catch-on-the-fly motor starting will be applied if *F 30 1* is set to 1 or 3 and:

- There is a brief power loss (the embedded display terminal does not go blank) that results in the drive removing power from the motor,
- and, there is a continuous run command to the drive (2-wire control)

F 30 1 Set to 1 or 3

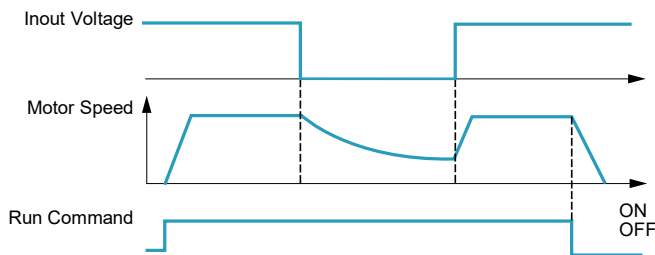

Catch-on-the-fly motor starting will be applied if *F 30 1* is set to 2 or 3 and:

- The run permissive (logic input assigned to functions 1 or 54) is removed and restored,
- and, there is a continuous run command to the drive (2-wire control)

F 30 1 Set to 2 or 3

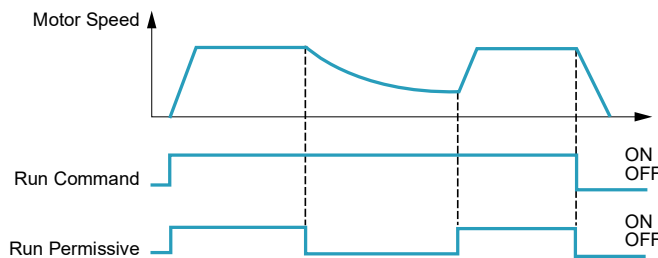

If *F 30 1* is set to 4, the drive will perform a motor speed and direction search each time it receives a run command.

Note: Enabling catch-on-the-fly adds about 300 milliseconds to implementation of each start command to the drive.



Do not use catch-on-the-fly if there is more than one motor supplied by the drive.

Code	Name / Description	Factory setting
<i>F 30 1</i>	[Catch on fly]	3 (1)
0	[Disable]	
1	[Brief power loss] After brief power loss	
2	[Run restored] After run permissive is restored	
3	[Power loss, run] After brief power loss or run permissive is restored	
4	[Each start] During every startup	
<i>F 632</i>	[Mot overload memo] Motor Overload Memory	0
0	[Disabled] Cleared If parameter <i>F 632</i> is set to 0, the drive's memory of the motor's thermal state (used for overload calculation) is cleared whenever the power is cycled.	
1	[Enabled] Retained If parameter <i>F 632</i> is set to 1, the drive's memory of the motor's thermal state is retained even when power is removed. If the drive is tripped on an Motor Overload detected fault <i>o L 2</i> , a cooling time (as calculated by the drive) needs to expire before the motor can be restarted.	

(1) Catch-on-the-fly motor starting after a drive detected fault is active if auto clear is enabled (parameter [Number auto reset] (*F 30 3*) is not set to 0, see page 135)

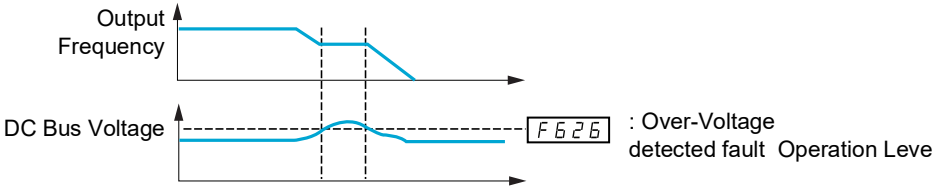
Code	Name / Description	Factory setting
F 6 0 2	[Drive fault memory]	0
0	[Cleared] If parameter F 6 0 2 is set to 0 and the drive is powered after a detected fault: If the cause of the detected fault has been removed, the drive will reset and can be started. Information about the detected fault just cleared will be transferred to the detected fault history. If the cause of the detected fault has not been removed, the detected fault will be displayed again but the drive's memory of the operational information associated with the detected fault will be transferred to the detected fault history. Information about the 4th most recent detected fault will be removed from the detected fault history.	
1	[Retained] If parameter F 6 0 2 is set to 1 and the drive is powered after a detected fault: If the cause of the detected fault has been removed, the drive will reset and can be started. Information about the detected fault just cleared will be transferred to the detected fault history. If the cause of the detected fault has not been removed, the original detected fault and all of its operational data will be available for viewing as the current detected fault in the monitoring mode. Information about the 4th most recent detected fault will be retained in the detected fault history. Auto clear will be disabled.	
F 6 0 8	[Input phase loss] Input phase loss detection mode	1
0	[Disable]: Disabled If parameter F 6 0 8 is set to 0, input phase loss detection is disabled. Loss of one input phase will not cause the drive to trip.	
1	[Enable]: Enabled If parameter F 6 0 8 is set to 1, the loss of one input phase will cause an E P H 1 detected fault.	
F 3 0 2	[Supply loss behav.]	0
0	[Disabled] If parameter F 3 0 2 is set to 0 and the drive briefly loses input power, it may not trip but may instead experience a momentary reduction of motor voltage and/or current and then resume normal operation once nominal input power is restored.	
1	[Do not use]: DO NOT SELECT	
2	[Freewheel] If parameter F 3 0 2 is set to 2 and the drive briefly loses input power, the drive will remove power from the motor and allow it to coast to a stop. The embedded display terminal will flash S E o P . The drive can only be restarted by providing a new run command.	
F 6 2 7	[Undervolt detect.] Undervoltage Fault Operation Mode	- 0
0	[Alarm (0.6U)]: Alarm only (detection level below 60 %) If parameter F 6 2 7 is set to 0 and the supply voltage drops below 60% of its rated value, the drive will stop and indicate a detected fault code on the embedded display terminal, but it will not activate a fault relay. If the supply voltage rises above 60% of its rated value, the detected fault code on the embedded display terminal will be cleared without a clear action and the drive will be ready to operate.	
1	[Fault (0.6U)]: Fault (detection level below 60 %) If parameter F 6 2 7 is set to 1 and the supply voltage drops below 60% of its rated value, the drive will trip and will require a reset action to clear the detected fault before it can be restarted.	
2	[Alarm (0.5U)]: Alarm only (detection level below 50 %) If parameter F 6 2 7 is set to 2 and the supply voltage drops below 50% of its rated value, the drive will stop and indicate a detected fault code on the embedded display terminal, but it will not activate a fault relay. If the supply voltage rises above 50% of its rated value, the detected fault code on the embedded display terminal will be cleared without a clear action and the drive will be ready to operate.	
NOTICE		
RISK OF DAMAGE TO DRIVE		
When F 6 2 7 = 2 , use a line choke.		
Failure to follow these instructions can result in death, serious injury, or equipment damage.		

F 3 0 5	[Overvoltage fault] Overvoltage protection	-	2
0	<p>[Enable] If parameter F 3 0 5 is set to 0, and the drive detects an impending DC bus overvoltage, it will automatically take one of the following actions: Increase the deceleration time Keep the motor at a steady speed Increase the motor speed</p> 		
1	<p>[Disabled] If parameter F 3 0 5 is set to 1, the drive will take no action to avoid a DC bus overvoltage.</p>		
2	<p>[Quick deceleration]: Enabled (quick deceleration mode) If parameter F 3 0 5 is set to 2, and the drive detects an impending DC bus overvoltage, it will increase the V/Hz ratio of the power applied to the motor. Motor over-excitation is used to dissipate regenerative energy into the motor instead of the drive.</p>		
3	<p>[Dyn. deceleration]: Enabled (dynamic quick deceleration mode) If parameter F 3 0 5 is set to 3, the drive will increase the V/Hz ratio of the power applied to the motor as soon as slow down begins instead of waiting for the DC bus voltage to approach the detected fault level.</p>		
<p>When motor speed is being reduced, a DC bus overvoltage can often be caused by regenerated energy being absorbed by the drive from the load and motor.</p>			
<p>Note: When the overvoltage limit operates, the inverter may drive beyond the maximum frequency [Max frequency] (F H). If the inverter drive beyond the internal setting frequency from maximum frequency [Max frequency] (F H), there may be an over-voltage trip.</p>			
<p>When the overvoltage limit function is active, an overvoltage error may occur if the operating frequency enters a steady state for a defined function.</p>			
F 6 2 6	[Overvoltage level]	100 to 150 % of nominal DC bus voltage	140%
<p>Parameter F 6 2 6 sets the DC bus voltage level at which the actions defined by parameter F 3 0 5 take place. See diagram above for more details.</p>			

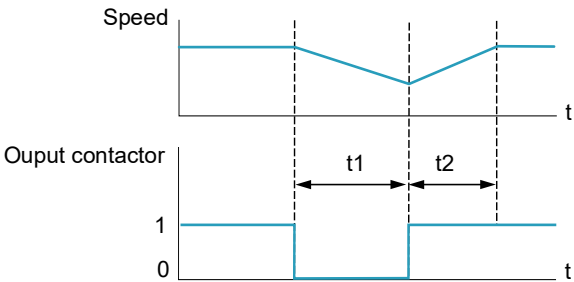
Code	Name / Description	Factory setting
F605	[Output phase loss] Output phase loss detection Mode	3
 DANGER		
<p>HAZARD OF ELECTRIC SHOCK, EXPLOSION OR ARC FLASH</p> <ul style="list-style-type: none"> ● If F605 = 0, loss of cable is not detected ● If F605 = 1 or 2, loss of cable is only detected at the startup of the motor ● Check this action will not endanger personnel or equipment in any way <p>Failure to follow these instructions will result in death or serious injury.</p>		
<p>Note: If [Mot cont. mode sel.] (Pt) is set to 6 (Permanent Magnet Motor Control Law) and [Output phase loss] (F605) is set to 1, 3, 4 and 5, the output phase loss check is done every time the motor is started.</p>		
 DANGER		
<p>HAZARD OF ELECTRIC SHOCK, EXPLOSION OR ARC FLASH</p> <p>If [Mot cont. mode sel.] (Pt) is set to 6 (Permanent Magnet Motor Control Law), output phase loss monitoring, while the motor is running, is disabled. Phase loss and, by implication, accidental disconnection of cables, are not detected. Verify that this behavior does not result in unsafe conditions and implement alternative monitoring function if required.</p> <p>Failure to follow these instructions will result in death or serious injury.</p>		
<p>If output phase loss detection is enabled and an output phase loss persists for more than 1 second, the drive will trip and display the EPHD code.</p>		
0	<p>[Disabled] If parameter F605 is set to 0, output phase loss detection is disabled.</p>	
1	<p>[First start]: At the first start-up, If parameter F605 is set to 1, an output phase loss check is made only during the first motor start-up after power is applied to the drive.</p>	
2	<p>[Each start]: At every start-up. If parameter F605 is set to 2, an output phase loss check is made every time the motor is started.</p>	
3	<p>[During run]: During operation, If parameter F605 is set to 3, continuous output phase loss monitoring is performed while the motor is running.</p>	
4	<p>[Permanent]: At start-up and during operation, If parameter F605 is set to 4, monitoring for an output phase loss is performed at motor start-up and continuously during operation.</p>	
5	<p>[Output contactor]: Load side disconnect mode, Setting 5 for parameter F605 is for applications with a load side disconnect. The drive will automatically restart the motor if the following are true:</p> <ul style="list-style-type: none"> - An all-phase loss has been detected (an output contactor or a load side disconnect has opened) - The drive detects that a 3-phase connection has been reestablished (the output contactor or load side disconnect has closed). It is necessary to wait 1 s between disconnection and connection. See following scheme to have an example of loss of output contactor. 	
 <p>The diagram consists of two vertically aligned plots sharing a common time axis 't'. The top plot shows 'Speed' on the y-axis. The speed starts at a constant high level, then ramps down linearly to a lower level (labeled t1), remains constant for a short duration, then ramps up linearly back to the high level (labeled t2). The bottom plot shows 'Output contactor' on the y-axis, with values 1 and 0. The contactor is at 1 during the initial constant speed phase, drops to 0 during the t1 deceleration phase, and returns to 1 during the t2 acceleration phase.</p>		
<p>t1: deceleration without ramp (freewheel) t2: acceleration with ramp</p>		
<p>- A valid run command exists. An output phase loss detection sweep is made as part of the auto-tuning process, regardless of the setting of parameter F605. High-speed motors and other special motors may cause nuisance output phase losses.</p>		

Code	Name / Description	Adjustment range	Factory setting
F 6 1 0	[Underload det.] Underload / alarm selection	-	0
0	[Alarm] If parameter F 6 1 0 is set to 0, relay output functions 24 or 25 (see page 141) can be used to signal an underload condition without the drive faulting.		
1	[Fault] If parameter F 6 1 0 is set to 1 and the loading level drops below the setting of F 6 1 1 for a period of time longer than that set by F 6 1 2 , the drive will trip, displaying code u C . The fault relay will be set if one has been defined (relay output functions 10 or 11, see page 108). A relay assigned to signal an underloaded condition (functions 24 or 25, see page 109) will also be set. The drive's response to an underload condition is set by parameters F 6 0 9 , F 6 1 0 , F 6 1 1 , and F 6 1 2 . The setting of parameter F 6 1 0 determines whether an underload condition signals an alarm with an output relay or faults the drive. The sum of parameters F 6 0 9 and F 6 1 1 determines the drive loading level that will clear an underload alarm/detected fault. Parameter F 6 1 2 determines how long the drive can be under load before an alarm or detected fault is signaled. See parameters F 6 0 9 , F 6 1 0 , F 6 1 1 and F 6 1 2 diagram below for more details. F 6 1 0 = 0 (Alarm Only)		
F 6 1 1	[Underload level] Underload Detection Level	0 to 100% (1)	0%
Parameter F 6 1 1 sets the underload detection level.			
F 6 0 9	[Underload band] Underload Detection Level Bandwidth	1 to 20% (2)	10%
F 6 1 2	[Underload det. time] Underload Detection Time	0 to 255 s	0 s
F 6 3 3	[Loss of VIA] Loss of VIA Analog Signal	0 to 100% (3)	0%
0	[Disabled] Disabled.		
1 to 100	[Fault detection level] If parameter F 6 3 3 is set to 0, the drive will not monitor for loss of signal at analog input terminal VIA. If parameter F 6 3 3 is set to a value greater than 0 and: The signal at VIA drops below the detection level selected, and, the low signal level persists for 300 milliseconds or longer, the drive will trip and the embedded display terminal will display the code E - 1 B .		

(1) Percentage of the drive's current rating. Display can also be in amperes, depending on setting of parameter **[Unit value selection] (F 7 0 1)** (see page 130).

(2) Percentage of **[Underload level] (F 6 1 1)** setting.

(3) Percentage of maximum VIA signal level

Code	Name / Description	Adjustment range	Factory setting
F 6 4 4	[4-20 mA loss] Drive behavior on 4-20 event		0
0	[No] : No		
1	[Freewheel] Freewheel. Freewheel stop and alarm.		
2	[Set speed] Fallback speed. Switch to fallback speed. Maintained as long as the trip cause is present and the run command is not disabled. See parameter [4-20mA fallback sp] (F 6 4 9) for fallback speed.		
3	[Keep speed] Speed maintain. The drive maintains the speed being applied when the trip occurred, as long as the trip cause is present and the run command is not disabled.		
4	[Ramp stop] Ramp stop.		
F 6 4 9	[4-20mA fallback sp] Fallback speed See parameter [4-20 mA loss] (F 6 4 4).	0.0 to [Max frequency] (F H)	0.0 Hz
F 6 1 3	[Short circuit det.] Output short-circuit detection mode	-	0
0	[Each time (std)] : Each time a RUN command is given (standard pulse)		
1	[One time (std)] : Only one time after power is turned on (standard pulse)		
2	[Each time (short)] : Each time a RUN command is given (short-time pulse)		
3	[One time (short)] : Only one time after power is turned on (short-time pulse)		
	The setting of parameter F 6 1 3 determines how the drive determines an output short-circuit during start-up. Select the short-time pulse if the drive is powering a low impedance motor.		

Overtorque Detection

The drive's response to a particular motor torque level is determined by the setting of parameters **F 6 15** – **F 6 19**.

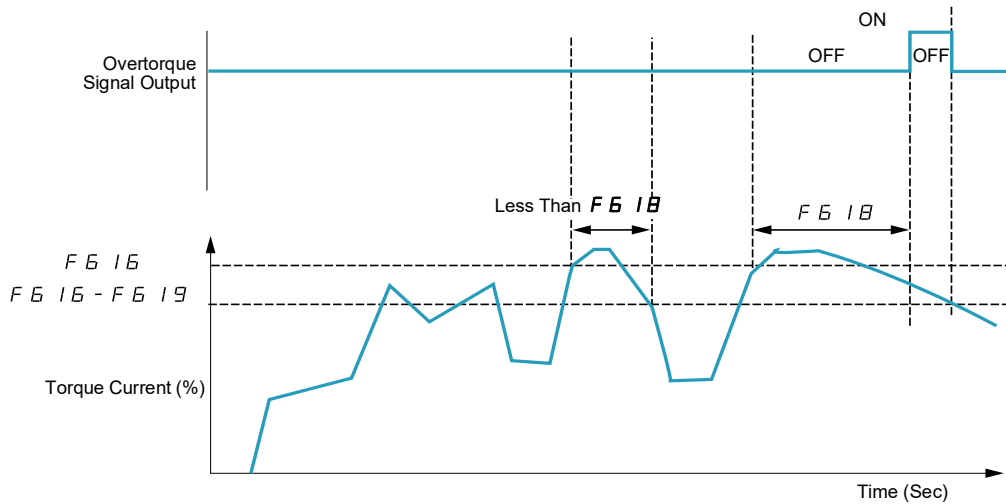

Code	Name / Description	Adjustment range	Factory setting
F 6 15	[Overtorque det.] Overtorque detected fault/Alarm Selection [Alarm] If parameter F 6 33 is set to 0, the drive will not monitor for loss of signal at analog input terminal VIA. [Fault] If parameter F 6 15 is set to 1 and the drive faults, the overtorque signal output will remain latched on until the detected fault is cleared. Depending on the setting of parameter F 6 15 , the drive can use output relay function 12 or 13 (see table on pages 108) to signal an overtorque alarm or detected fault (o t code).	-	0
F 6 16	[Overtorque level] Overtorque Detection Level The setting of parameter F 6 16 determines the level at which the drive will act upon a motor overtorque condition (see diagrams above and below).	0 to 250 % of nominal rated motor torque	130%
	<p>Output relay functions 20 or 21 can be used to signal a overtorque pre-alarm when the calculated motor torque reaches 70% of the value set by parameter F 6 16.</p>		
F 6 18	[OvTorque det time] Overtorque Detection Time The setting of parameter F 6 18 determines how long the drive needs to detect a motor overtorque condition before it signals an alarm or detected fault (see above diagram).	0.0 to 10 s	0.5 s
F 6 19	[Overtorque band] Overtorque Detection Level Bandwidth While the setting of parameter F 6 16 determines the level at which a motor overtorque alarm or detected fault will be signaled, the setting of parameter F 6 19 determines how far the calculated motor torque needs to drop before the alarm or detected fault is cleared (see above diagram).	0 to 100 % of F 6 16 level	10%

Code	Name / Description	Factory setting
F 6 3 4	[Amb. temp. alarm] Ambient Temperature For drive Service Alarm	3
1	[- 10 to 10 °C]	
2	[11 to 20 °C]	
3	[21 to 30 °C]	
4	[31 to 40 °C]	
5	[41 to 50 °C]	
6	[51 to 60 °C]	
	The drive can be programmed to signal a service alarm using output relay functions 44 or 45 (see page 112). The status of the service alarm can be displayed on the embedded display terminal (see page 21).	
	At initial start-up, set parameter F 6 3 4 to the drive's average ambient operating temperature. Setting F 6 3 4 to the highest annual temperature or changing the value after drive operation has begun may result in an early drive service alarm.	

Nuisance Overvoltage And Input Phase Detected Fault Avoidance

Parameters **F 4 B 1** to **F 4 B 3** can be used to avoid nuisance overvoltage and input phase faults caused by:

- High input impedance: line reactor
- Low input impedance: high kVA distribution network
- Voltage instability: generator power source

If nuisance faults occur, increase the value of parameter **F 4 B 1**. If increasing the value of **F 4 B 1** over 1000 does not remove nuisance faults, increase the values of parameters **F 4 B 2** and **F 4 B 3** as needed.

Code	Name / Description	Adjustment range	Factory setting
F 4 B 1	[Ln noise comp. filter] Line noise compensation filter	0 to 9999 μ s	0 μ s
F 4 B 2	[Ln noise Inhibit filter] Line noise Inhibitor filter	0 to 9999 μ s	442 μ s
F 4 B 3	[Ln noise inhibit gain] Line noise Inhibitor gain	0 to 300 %	100%
F 4 B 4	[Pwr supply adj. gain] Power supply adjustment gain	0.0 to 2.0 s	0.0

When the using machine has specific resonance, the following phenomena are happened:

- the machine occurs vibration,
- unusual noise of machine or peripheral.

If these phenomena are occurred, the following parameters should be adjusted:

- at first, set **[Pwr supply adj. gain]** (**F 4 B 4**) to 0.5,
- next, set **F 4 B 4** as another value when no effect by setting **F 4 B 4** to 0.5,
- if **[Motor rated freq.]** (ωL) = 50 Hz, set **F 4 B 1** to the following value 531,
- if ωL = 60 Hz, set **F 4 B 1** to the following value 442.

Note: **F 4 B 1** and **F 4 B 3** are invalid when **F 4 B 4** has a value excluding 0.0.

Motor Overload Characteristics

Motor Type

Set $\alpha L \Pi$ to $0, 1, 2,$ or 3 if a self-cooled motor is being powered by the drive. The diagram below illustrates the overload protection level for the self-cooled motor as a function of motor frequency.

Overload Protection for a Self-Cooled Motor

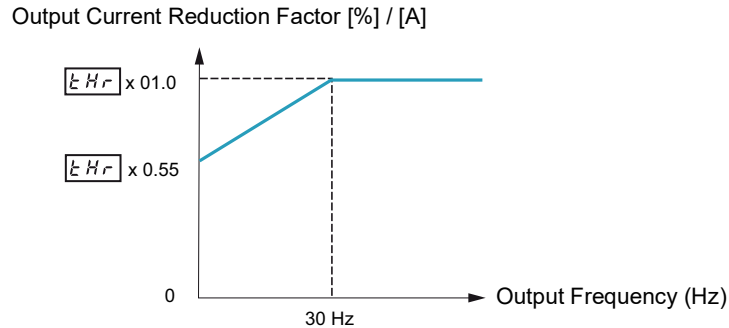

Set $\alpha L \Pi$ to $4, 5, 6,$ or 7 if a forced-cooled motor is being powered by the drive. The diagram below illustrates the overload protection level for the forced-cooled motor as a function of motor frequency.

Overload Protection for a Forced-Cooled Motor

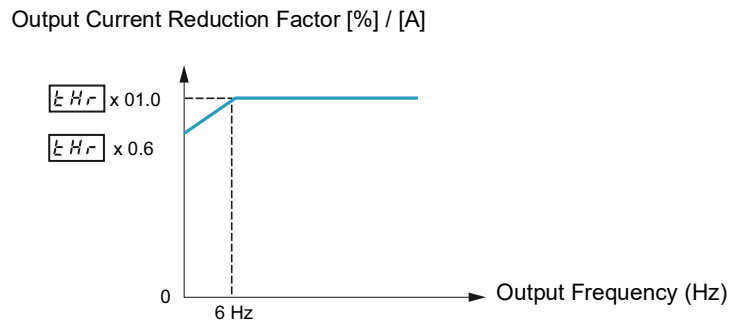

Overload Protection

To enable motor overload protection, set $\alpha L \Pi$ to $0, 1, 4,$ or 5 .

NOTICE

RISK OF DAMAGE TO THE MOTOR

When $\alpha L \Pi$ is set to $2, 3, 6$ or 7 motor thermal protection is no longer provided by the drive. Provide an alternative means of thermal protection.

Failure to follow these instructions can result in equipment damage.

To disable motor overload protection, set $\alpha L \Pi$ to $2, 3, 6,$ or 7 . In this case, a separate overload protective device, external to the ATV212 drive, needs to be wired between the drive and the motor.

Overload Stall

The overload stall function is only compatible with variable torque loads where the load on the motor and drive is dependent on the operating frequency and where the load can be reduced by slowing the motor.

If overload stall is enabled, the drive will reduce its output frequency if it detects an impending overload. As the overload condition of the motor is dissipated, the drive will return its output frequency to the commanded value.

To enable overload stall, set $\alpha L \Pi$ to $1, 3, 5,$ or 7 .

To disable overload stall, set $\alpha L \Pi$ to $0, 2, 4,$ or 6 .

Code	Name / Description	Factory setting			
o L n	[Motor overload prot] Motor Overload Characteristics	0			
NOTICE					
RISK OF DAMAGE TO THE MOTOR					
When o L n is set to 2, 3, 6 or 7 motor thermal protection is no longer provided by the drive. Provide an alternative means of thermal protection. Failure to follow these instructions can result in equipment damage.					
This parameter value depends on: <ul style="list-style-type: none"> - the motor type (self cool or forced cooled), - and the protection. 					
Motor type	Protection		o L n value	Description	Behavior
	Overload protection	Overload stall			
Self cooled	enabled	disabled	0	[Std mot. protect.]	In case of overload defined by [Motor thermal prot.] (t H r) parameter, the drive trips in o L 2 and the letter L is flashing.
	enabled	enabled	1	[Std & stall mot. prot]	In case of overload defined by [Motor thermal prot.] (t H r) parameter, the drive reduces automatically the speed and follows a fallback speed (80 % of Motor rated frequency u L) (1). If the overload remains during the fallback speed, the drive trips in o L 2 and the letter L is flashing.
	disabled	disabled	2	[Self cool]	-
	disabled	enabled	3	[Sif cool stall ov.load]	In case of overload defined by [Motor thermal prot.] (t H r) parameter, the drive reduces automatically the speed and follows a fallback speed (80 % of Motor rated frequency u L) (1). The drive will not trip in o L 2 .
Forced cooled	enabled	disabled	4	[Forced cool prot]	In case of overload defined by [Motor thermal prot.] (t H r) parameter, the drive trips in o L 2 and the letter L is flashing.
	enabled	enabled	5	[Forc cool stall prot]	In case of overload defined by [Motor thermal prot.] (t H r) parameter, the drive reduces automatically the speed and follows a fallback speed (80 % of Motor rated frequency u L) (1). If the overload remains during the fallback speed, the drive trips in o L 2 and the letter L is flashing.
	disabled	disabled	6	[Forced cool]	-
	disabled	enabled	7	[F cool & stall ov load]	In case of overload defined by [Motor thermal prot.] (t H r) parameter, the drive reduces automatically the speed and follows a fallback speed (80 % of Motor rated frequency u L) (1). The drive will not trip in o L 2 .

(1) If the speed is lower than the fallback speed, the drive will keep the same speed.

Serial Communication Parameters

11

What's in this Chapter?

This chapter contains the following topics:

Topic	Page
Network communication between the ATV212 drive and a master controller	148
Data structure parameters	150

Network communication between the ATV212 drive and a master controller

⚠ WARNING

LOSS OF CONTROL

- The designer of any control scheme must consider the potential failure modes of control paths and, for certain critical control functions, provide a means to achieve a safe state during and after a path failure. Examples of critical control functions are emergency stop and overtravel stop.
- Separate or redundant control paths must be provided for critical control functions.
- System control paths may include communication links. Consideration must be given to the implications of unanticipated transmission delays or failures of the link (1).

Failure to follow these instructions can result in death, serious injury, or equipment damage.

(1) For additional information, refer to NEMA ICS 1.1 (latest edition), "Safety Guidelines for the Application, Installation, and Maintenance of Solid State Control" and to NEMA ICS 7.1 (latest edition), "Safety Standards for Construction and Guide for Selection, Installation and Operation of Adjustable-Speed Drive Systems."

Network communication between the ATV212 drive and a master controller is possible through five protocols selectable through the embedded display terminal:

- Modbus® RTU
- Metasys® N2
- Apogee® P1 FLN
- BACnet
- LonWorks®

Three types of data exchange are possible:

- Monitoring: monitoring values such as output frequency, voltage, and current
- Programming: reading, editing, and writing drive parameters
- Control: starting and stopping the drive and controlling the frequency reference



For operation on a network containing multiple drives, each ATV212 drive needs to be assigned a unique address using parameter **F B 0 2**.

For operation on a network where all drives are slaves responding to a central control system:

- Parameters **[Command mode sel] (C n o d)** (see page 87) and **[Frequency mode sel] (F n o d)** (see page 87) needs to be set correctly:
 - Setting **C n o d** to 2 enables start/stop control of the drive via network communication
 - Setting **F n o d** to 4 enables the frequency reference to be controlled by network communication
 - Setting either **C n o d** to 2 or **F n o d** to 4 enables serial communication error detection. The setting of parameter **F B 5 1** determines the drive's response in case of a loss of communication.

Control of the ATV212 drive can be established by a master controller over a serial communication network regardless of the setting of **C n o d** or **F n o d** (see diagram on page 50). Control can be restored to the source defined by **C n o d** and **F n o d** if the serial communication network relinquishes control or a logic input assigned to function 48 (forced local) is enabled.

Code	Name / Description	Adjustment range	Factory setting
F B 0 0 0 1	[Mdb RJ45 baud] Modbus RJ45 baud rate [9600 bps] [19200 bps]	-	1
F B 0 1 0 1 2	[Mdb RJ45 parity] Modbus RJ45 parity [No]: No parity [Even]: Even parity [Odd]: Odd parity	-	1
F B 0 2	[Modbus address] This address is used whatever the port used.	0 to 247	1

Code	Name / Description	Adjustment range	Factory setting
F B 0 3	[Com. time out]	-	3
 WARNING			
LOSS OF CONTROL <ul style="list-style-type: none"> • If F B 0 3 is set to 0, communication control will be inhibited. • For safety reasons, inhibiting the communication interruption detection should be restricted to the debug phase or to special applications. Failure to follow these instructions can result in death, serious injury, or equipment damage.			
0 1 to 100	Communication error detection disabled 1 to 100 seconds		
F B 2 0	[Mdb network baud] Modbus network baud rate	-	1
0 1	[9600] [19200]		
F B 2 1	[Mdb network parity] Modbus network parity	-	1
0 1 2	[No]: No parity [Even]: Even parity [Odd]: Odd parity		
F B 2 9	[Network protocol] Network protocol selection	-	1
1 2 3 4 5	[Mdb RTU] [Metasys N2] [Apogee P1] [BACnet] [LonWorks]		
F B 2 9 is enable if F B 0 7 is set to 1 previously. Note: On the ATV21, Lonworks configuration corresponded to value 1 .			
F B 5 1	[Com. fault setting] Communication fault setting	-	4
 WARNING			
LOSS OF CONTROL If F B 5 1 is set to 1 , communication control will be inhibited. For safety reasons, inhibiting the communication interruption detection should be restricted to the debug phase or to special application. Failure to follow these instructions can result in death, serious injury, or equipment damage.			
 WARNING			
LOSS OF CONTROL Know and understand the setting of parameter F B 5 1 . This parameter controls the behavior of the drive in the event of a network communication loss. If the value of F B 5 1 is 0 , 1 , 2 , or 3 , the drive will not trip on an ErrB . Failure to follow these instructions can result in death, serious injury, or equipment damage.			
0 1 2 3 4	Ramp stp (F/Cmod): Drive ramps to a stop. Serial control is relinquished to the sources defined by [Frequency mode sel] (F P o d) and [Command mode sel] (C P o d). This function is only used with the Lonworks terminal board. [No active]: Last commanded operation continues. [Ramp stop]: Drive ramps to a stop. Serial control is maintained. [Freewheel]: Drive removes power from the motor which coasts to a stop. Serial control is maintained. [Err5 or Err8]: Drive faults with either a communication detected fault Err5 or a network detected fault ErrB .		
Note: For Modbus connection, only the function 1 is taken into account. The other function make drive trip in ErrB or Err5 .			
F B 0 7	[Com channel choice] Communication channel choice	-	1
0 1	[RJ45]: command Modbus via RJ45 port. [Open style]: Modbus, BACnet, Apogee P1, Metasys N2 and Lonworks defined by [Network protocol] F B 2 9 via open style port. F B 0 7 can only be adjusted while the drive is stopped.		

Data structure parameters

Parameters **F B 5 6– F B 8 0** define the structure of data transmitted between the drive and the data communication network

Code	Name / Description	Factory setting
F B 5 6	[Mot. poles (comm.)] Number of motor poles for communication	2
<i>1</i>	[2 poles]	
<i>2</i>	[4 poles]	
<i>3</i>	[6 poles]	
<i>4</i>	[8 poles]	
<i>5</i>	[10 poles]	
<i>6</i>	[12 poles]	
<i>7</i>	[14 poles]	
<i>8</i>	[16 poles]	
F B 7 0	[Block write data 1]	0
<i>0</i>	[No select]: No selection	
<i>1</i>	[Command word 1]	
<i>2</i>	[Command word 2]	
<i>3</i>	[Frequency Setpoint]	
<i>4</i>	[Relay command]: Ouput data on the terminal board	
<i>5</i>	[FM command]: Analog output for communication	
<i>6</i>	[Speed Setpoint]	
F B 7 1	[Block write data 2]	0
<i>0</i>	[No select]: No selection	
<i>1</i>	[Command word 1]	
<i>2</i>	[Command word 2]	
<i>3</i>	[Frequency Setpoint]	
<i>4</i>	[Relay command]: Ouput data on the terminal board	
<i>5</i>	[FM command]: Analog output for communication	
<i>6</i>	[Speed Setpoint]	
F B 7 5	[Block read data 1]	0
<i>0</i>	[No select]: No selection	
<i>1</i>	[Status info]	
<i>2</i>	[Freq. out]: Output frequency	
<i>3</i>	[Motor current]: Ouput current	
<i>4</i>	[Ouput volt]: Ouput voltage	
<i>5</i>	[Alarm info]: Alarm information	
<i>6</i>	[PID feedback value]	
<i>7</i>	[Input term. mon]: Input terminal board monitor	
<i>8</i>	[Out term. mon]: Output terminal board monitor	
<i>9</i>	[VIA monitor]: VIA terminal board monitor	
<i>10</i>	[VIB monitor]: VIB terminal board monitor	
<i>11</i>	[Mot speed mon.]: Ouput motor speed monitor	
F B 7 6	[Block read data 2]	0
<i>0</i>	[No select]: No selection	
<i>1</i>	[Status info]	
<i>2</i>	[Freq. out]: Output frequency	
<i>3</i>	[Motor current]: Ouput current	
<i>4</i>	[Ouput volt]: Ouput voltage	
<i>5</i>	[Alarm info]: Alarm information	
<i>6</i>	[PID feedback value]	
<i>7</i>	[Input term. mon]: Input terminal board monitor	
<i>8</i>	[Out term. mon]: Output terminal board monitor	
<i>9</i>	[VIA monitor]: VIA terminal board monitor	
<i>10</i>	[VIB monitor]: VIB terminal board monitor	
<i>11</i>	[Mot speed mon.]: Ouput motor speed monitor	

Code	Name / Description	Factory setting
F B 7 7	[Block read data 3]	0
0	[No select]: No selection	
1	[Status info]	
2	[Freq. out]: Output frequency	
3	[Motor current]: Output current	
4	[Output volt]: Output voltage	
5	[Alarm info]: Alarm information	
6	[PID feedback value]	
7	[Input term. mon]: Input terminal board monitor	
8	[Out term. mon]: Output terminal board monitor	
9	[VIA monitor]: VIA terminal board monitor	
10	[VIB monitor]: VIB terminal board monitor	
11	[Mot speed mon.]: Output motor speed monitor	
F B 7 8	[Block read data 4]	0
0	[No select]: No selection	
1	[Status info]	
2	[Freq. out]: Output frequency	
3	[Motor current]: Output current	
4	[Output volt]: Output voltage	
5	[Alarm info]: Alarm information	
6	[PID feedback value]	
7	[Input term. mon]: Input terminal board monitor	
8	[Out term. mon]: Output terminal board monitor	
9	[VIA monitor]: VIA terminal board monitor	
10	[VIB monitor]: VIB terminal board monitor	
11	[Mot speed mon.]: Output motor speed monitor	
F B 7 9	[Block read data 5]	0
0	[No select]: No selection	
1	[Status info]	
2	[Freq. out]: Output frequency	
3	[Motor current]: Output current	
4	[Output volt]: Output voltage	
5	[Alarm info]: Alarm information	
6	[PID feedback value]	
7	[Input term. mon]: Input terminal board monitor	
8	[Out term. mon]: Output terminal board monitor	
9	[VIA monitor]: VIA terminal board monitor	
10	[VIB monitor]: VIB terminal board monitor	
11	[Mot speed mon.]: Output motor speed monitor	

Code	Name / Description	Adjustment range	Factory setting
F B B 0	[Free ID parameter] Free Notes	0 to 65535	0
	The free notes parameter can be used to set a unique value to identify the drive on a network.		

Parameters *F B 9 0 – F B 9 6* should be adjusted only if the corresponding optional equipment has been installed. See the ATV212 catalog for more detail.

Code	Name / Description
<i>F B 9 0</i>	[Network address]
<i>F B 9 1</i>	[Network baud rate]
<i>F B 9 2</i>	[Network time out]
<i>F B 9 3</i>	[Instance number H]
<i>F B 9 4</i>	[Instance number L]
<i>F B 9 5</i>	[Max master]
<i>F B 9 6</i>	[Max info frames]

When the value of *F B 2 9* parameter is changed, the adjustment range and factory setting of *F B 9 0* to *F B 9 6* are automatically setted.

	Modbus		APOGEE FLN P1		METASYS N2		BACNET	
	Setting Range	Factory setting	Setting Range	Factory setting	Setting Range	Factory setting	Setting Range	Factory setting
<i>F B 2 9</i>	-	1	3	3	2	2	4	4
<i>F B 9 0</i>	0 to 65535	0	1 to 99	99	1 to 255	1	0 to 127	0
<i>F B 9 1</i>			0 to 6	0	1 to 5	5	1 to 5	5
<i>F B 9 2</i>			20 to 600	100	20 to 600	100	20 to 600	100
<i>F B 9 3</i>			0 to 4194	0	0 to 4194	0	0 to 4194	0
<i>F B 9 4</i>			0 to 999	0	0 to 999	0	0 to 999	0
<i>F B 9 5</i>			0 to 127	0	0 to 127	0	0 to 127	127
<i>F B 9 6</i>			0 to 100	0	0 to 100	0	1 to 100	1

There are 2 connection port with support different communication protocol, embedded or using option board. The two channels could communicate simultaneously with the product, but only one could send the logical or frequency command to the drive:

- The two channel used for monitoring
- One channel used for command (run order and speed) and the second for monitoring.

The configuration parameters of communication are taking account at next power up of the product.

	Description	RJ45 Modbus	Network Modbus	Network Apogee P1	Network Metasys N2	Network BACnet	Network LonWorks
<i>F B 2 9</i>	Network selection	-	•	•	•	•	•
<i>F B 0 0</i>	Modbus RJ45 Baud rate	•	-	-	-	-	-
<i>F B 0 1</i>	Modbus RJ45 Parity	•	-	-	-	-	-
<i>F B 0 2</i>	Modbus address	•	•	-	-	-	-
<i>F B 0 3</i>	Modbus time out	•	•	-	-	-	(1)
<i>F B 5 1</i>	Com fault behavior	•	•	•	•	•	•
<i>F B 2 0</i>	Modbus Net Baud rate	-	•	-	-	-	-
<i>F B 2 1</i>	Modbus Net Parity	-	•	-	-	-	-
<i>F B 9 0</i>	Network parameter	-	-	•	•	•	-
<i>F B 9 1</i>	Network parameter	-	-	•	-	•	-
<i>F B 9 2</i>	Network parameter	-	-	•	•	•	-
<i>F B 9 3</i>	Network parameter	-	-	-	-	•	-
<i>F B 9 4</i>	Network parameter	-	-	-	-	•	-
<i>F B 9 5</i>	Network parameter	-	-	-	-	•	-
<i>F B 9 6</i>	Network parameter	-	-	-	-	•	-

(1) Time out disconnection board, internal default value (3s)

Start/Stop Control By Speed Reference Level

12

What's in this Chapter?

This chapter contains the following topics:

Topic	Page
Overview	154

Overview

Use parameters **[Freq. pedestal]** ($F 2 4 1$) and **[Freq. pedestal hyst.]** ($F 2 4 2$) to enable start/stop control of the drive based on the speed reference level.

If the drive operates normally and has a run permissive signal, it will start powering the motor as soon as the speed reference level exceeds the frequency set by $F 2 4 1 + F 2 4 2$ (point B in diagram below). It will remove power from the motor as soon as the output frequency drops below the level set by $F 2 4 1 - F 2 4 2$ (point A in diagram below).

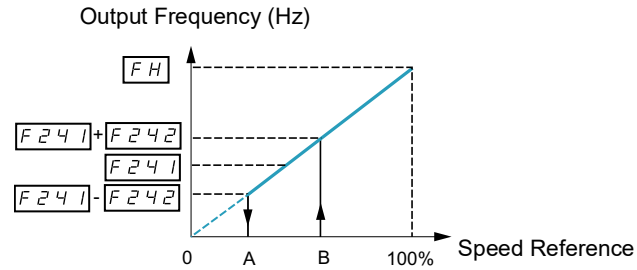

Code	Name / Description	Adjustment range	Factory setting
$F 2 4 1$	[Freq. pedestal] Operating starting frequency]	0.0 to [Max frequency] ($F H$) Hz	0.0 Hz
$F 2 4 2$	[Freq. pedestal hyst.] Operating starting frequency hysteresis	0.0 to [Max frequency] ($F H$) Hz	0.0 Hz

Droop Control

13

What's in this Chapter?

This chapter contains the following topics:

Topic	Page
Droop control principle	156

Droop control principle

The use of droop control (or negative slip compensation) can help balance the load between multiple motors in a load sharing application. The amount of slip or speed droop allowed in the motor powering the load is determined by the load current level and the setting of parameters **F 3 2 0** and **F 3 2 3**.

During motoring, droop control decreases the drive output frequency. During regenerative braking, droop control increases the drive output frequency.

When enabled, droop control is active when:

- The load current exceeds the level set by parameter **F 3 2 3**.
- The drive output frequency is between the [Mot start freq.] **F 2 4 0** (see page 92) and [Max frequency] (**F H**) (see page 92).

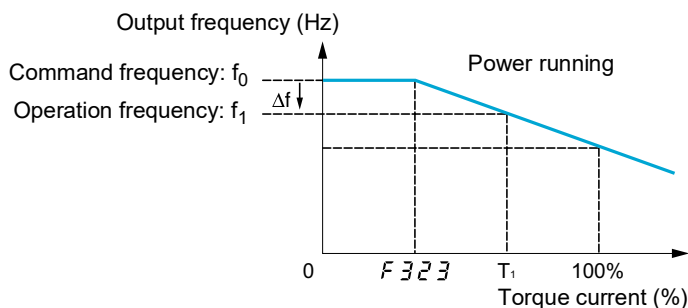

The amount of speed droop allowed (f) can be calculated by this equation:

$$f = \omega L (1) \times F 3 2 0 \times (\text{load current} - F 3 2 3)(2)$$

Example:

$$\omega L = 60 \text{ Hz}$$

$$F 3 2 0 = 10\%$$

$$F 3 2 3 = 30\% \text{ (of drive's rated current)}$$

Load current = 100% of drive's rating

$$f = 60 \times 0.1 \times (1 - 0.3)$$

$$f = 60 \times 0.07$$

$$f = 4.2$$

Assuming the speed reference is set to 60 Hz, the output frequency will be: $f_1 = f_0 - f = 60 - 4.2 = 55.8 \text{ (Hz)}$.

Code	Name / Description	Adjustment range	Factory setting
F 3 2 0	[Load gain]	0 to 100%	0%
F 3 2 3	[Load gain offset]	0 to 100% (3)	10%

- (1) Parameter [Motor Rated freq] (ωL) (see page 74). The value entered for ωL in this formula should not exceed 100, regardless of the actual setting of parameter ωL .
- (2) Speed droop is zero if (load current - **F 3 2 3**) = 0.
- (3) Percent of the drive's rated current.

Functions for Scroll

14

What's in this Chapter?

This chapter contains the following topics:

Topic	Page
Driving Scroll (F324)	160
Pre-start Scroll (F325)	170
Std Oiling Cycle (F330)	172
Low Speed Oiling (F334)	173
Scroll Protection (F338)	174
Discharge gas (F349)	175
Crankcase heating (F355)	176

Scroll sub menu ([[SCROLL MENU](#)] ([5 Cr](#)))

ATV212 have 7 specific functions dedicated to the management of a scroll compressor with variable speed operation integrated into an HVAC production system. The main purpose of these functions is to help protect the compressor, the engine, and the system against the risk of mechanical damage inherent to the operating conditions.

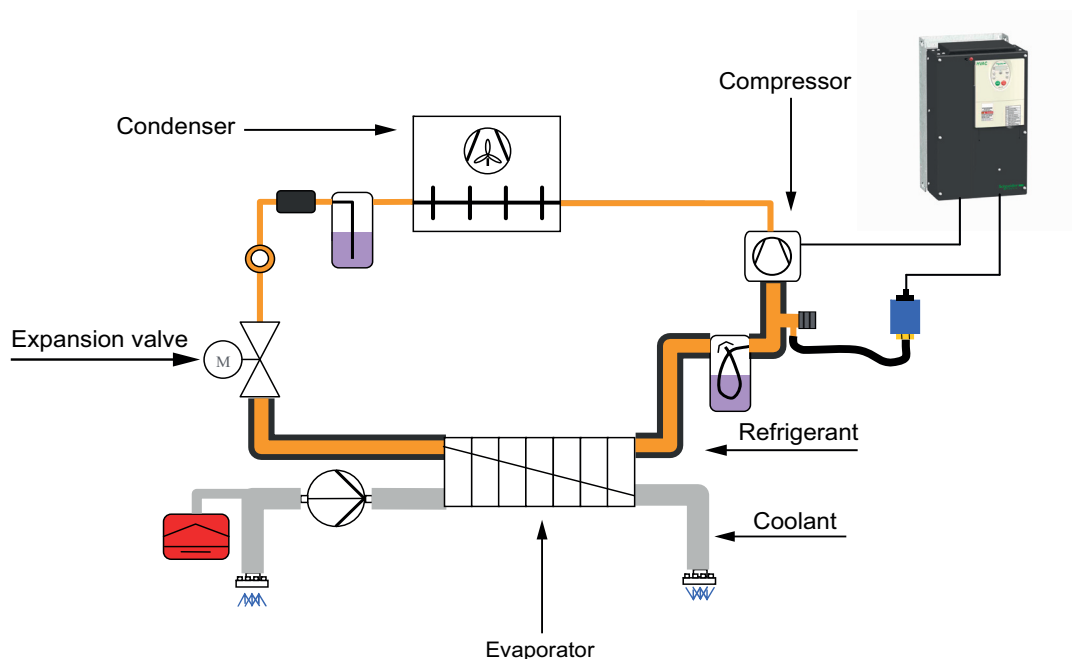

- **General setting of the motor control of a Scroll compressor:**

- [[Driving Scroll](#)] ([F 3 2 4](#)) Driving a Scroll Compressor. (See page [160](#))
When this function is activated, default value of some parameters change (see the table page [159](#)).
This function also allows taking into account the characteristics of the motor for optimum control.

- **Scroll Compressor Operating Functions:**

- [[Pre-start Scroll](#)] ([F 3 2 5](#)) Scroll Compressor Pre-start Management. (See page [170](#))
On each run order, the variable speed drive ensures that the scroll compressor starts under good conditions.
- [[Std Oiling Cycle](#)] ([F 3 3 0](#)) Periodic Oiling Cycle Management. (See page [172](#))
The variable speed drive manages the lubrication cycle of the Scroll Compressor during normal operation.
- [[Low Speed Oiling](#)] ([F 3 3 4](#)) Oiling management for Low Speed Running. (See page [173](#))
The variable speed drive initiates a cycle of the scroll compressor lubrication after a continuous period of operation below a threshold speed.

- **Scroll compressor and refrigerant loop protection functions:**

- [[Scroll Protection](#)] ([F 3 3 B](#)) Avoid Overloading or Cavitations Effects. (See page [174](#))
By monitoring thresholds of current and output frequency, the variable speed drive stops the motor in case of overcharging or cavitations.
- [[Discharge Gas](#)] ([F 3 4 9](#)) Avoid high temperature or high pressure through sensor input. (See page [175](#))
By monitoring an analog threshold (pressure sensor and temperature on the refrigerant circuit), the drive stops the motor.
- [[Crankcase Heating](#)] ([F 3 5 5](#)) Keep the system warm after motor sopped. (See page [176](#))
To avoid internal condensation effects, the variable speed drive maintains the temperature of the compressor by injecting current into the motor. This replaces an external heating system for compressors with built-in motor.

Activation of functions

[Driving Scroll] (F 3 2 4) must be set to (1) to activate the 7 specific functions. (See below)

Example: (F 3 2 5) [Pre-start Scroll] can be set (0) to (1), if F 3 2 4 = (0) then F 3 2 5 is deactivated.

Code	Name	Adjustment range	Automatic values
F 3 2 5	[Pre-start Scroll]	0 - 1	0
F 3 3 0	[Std Oiling Cycle]	0 - 1	0
F 3 3 4	[Low Speed Oiling]	0 - 1	0
F 3 3 8	[Scroll Protection]	0 - 1	0
F 3 4 9	[Discharge Gas]	0 - 1	0
F 3 5 5	[Crankcase Heating]	0 - 1	0

Automatic values of parameters

These parameters will be changed automatically when [Driving Scroll] (F 3 2 4) changes from [No] (0) to (1) [Yes].

Code	Name	Factory setting	Automatic values
F 3 1 1	[Motor direction]	1 [FW only]	1 [FW only]
P L	[Mot cont. mode sel.]	1 [Variable Torque]	3 [SVC]
u L	[Motor rated freq.]	50 Hz	50 Hz
F 6 0 1	[Motor Current Limit]	110 %	110 %
L L	[Low limit frequency]	0.0 Hz	30 Hz
u L	[Upper limit freq]	50 Hz	90 HZ
F H	[Max frequency]	50 Hz	90 Hz
F 4 0 1	[Slip Compensation]	50 %	0 %
d E C	[Deceleration time 1]	According to drive rating (1)	0.9 s
A C C	[Acceleration time 1]	According to drive rating (1)	0.9 s
F 1 3 0	[RY Relay Function 1]	4 [F100 speed reach]	70 [DisOil Inj PL]
F 1 3 2	[FL Relay Function]	11 [No drive fault]	9 [Inv F101 sp reach]
F 1 0 1	[Freq. 2 reached]	0.0 [0.0 Hz]	65 [65 Hz]
F 1 0 2	[Freq.2 bandw.]	2.5 [2.5 Hz]	0.65 [0.65 Hz]
F 1 1 3	[LI RES selection]	10 [Fault reset]	54 [Inverse Run permis.]
F 2 5 0	[DC brake start freq.]	0 Hz	0 Hz
F 2 5 1	[DC braking current]	50 %	10 %
F 3 0 1	[Catch on fly]	3 [Power loss, run]	0 [Disable]

(1) see table page 199

Note: When (F 3 2 4) changes from [Yes] to (1) to [No] (0), linked parameters values are not changed.

Driving Scroll (F324)

This section will regroup basics parameters to ensure a good control and performance for the [\[Driving Scroll\] \(F 3 2 4\)](#).

⚠ DANGER
<p>UNINTENDED EQUIPMENT OPERATION</p> <p>Enabling Driving Scroll parameter (F324) will modify the setting of some parameters (see page 159). All previous setting of these parameters will be lost.</p> <ul style="list-style-type: none"> • Modify only these parameters after activation of Driving Scroll parameter (F324). <p>Failure to follow these instructions will result in death or serious injury.</p>

Code	Name / Description	Adjustment range	Factory setting
<p>F 3 2 4</p> <p>0 1</p>	<p>[Driving Scroll] Driving a Scroll Compressor</p> <p>Motor characteristics and control parameters.</p> <p>[No] [Yes]</p> <p>Automatic values of parameters changes when F 3 2 4 changes from 0 to 1, see the table page 159</p>	-	0
<p>F 3 1 1</p> <p>(1)</p> <p>0 1 2</p>	<p>[Motor direction]</p> <p>If [Driving Scroll] (F 3 2 4) page 160 is set to [Yes] (1) the setting is replaced by [FW only] (1).</p> <p>Use parameter F 3 1 1 to permit only forward or reverse operation.</p> <p>[Fw & Rev.] [Fw only] [Rev. only]</p>	-	1 [FW only]
<p>P 1</p> <p>(1)</p> <p>0 1 2 3 4 5 6</p>	<p>[Mot cont. mode sel.] Motor control mode</p> <p>If [Driving Scroll] (F 3 2 4) page 160 is set to [Yes] (1) the setting is replaced by [SVC] (3).</p> <p>[Constant V/Hz]: Constant V/Hz [Variable Torque]: Variable torque [Cst V/Hz+Boost]: Constant V/Hz with automatic torque boost [SVC]: Sensorless vector control [Economy]: Energy saving [Do not use]: Reserved [PM Control]: Permanent Magnet Motor Control Law</p>	-	1
⚠⚠ DANGER			
<p>HAZARD OF ELECTRIC SHOCK, EXPLOSION OR ARC FLASH</p> <p>If [Mot cont. mode sel.] (P 1) is set to (6) (Permanent Magnet Motor Control Law), output phase loss monitoring, while the motor is running, is disabled. Phase loss and, by implication, accidental disconnection of cables, are not detected.</p> <ul style="list-style-type: none"> • Verify that this behavior does not result in unsafe conditions and implement alternative monitoring function if required. <p>Failure to follow these instructions will result in death or serious injury.</p>			
<p>u L u</p>	<p>[Motor Rated Voltage]</p> <p>Set parameter u L u (vLv) to the motor's rated voltage as indicated on the motor nameplate.</p> <p>ATV212●●●M3X: 50...330 V. ATV212●●●N4: 50...660 V</p> <p>Note: Drive output voltage cannot be set to exceed the input line voltage level.</p>	According to drive rating (2)	According to drive rating (2)

- (1) When [\(F 3 2 4\)](#) changes from **[No] (0)** to **[Yes] (1)**, some of linked parameters are set to a new value.
When [\(F 3 2 4\)](#) changes from **[Yes] (1)** to **[No] (0)**, linked parameters value are not changed.
- (2) See table page 199

<p>vL</p> <p>(1)</p>	<p>[Motor rated freq.]</p> <p>If [Driving Scroll] (F 3 2 4) page 160 is set to [Yes] (1) the setting is replaced by 50.0 Hz.</p> <p>Set parameter vL to the motor's rated frequency as indicated on the motor nameplate.</p> <p>Note: It is possible to set the drive's various motor control frequencies to 50 Hz by setting [Parameter reset] (E 9 P) to 1, the 50 Hz reset. For more information, see page 66.</p>	<p>25...400 Hz</p>	<p>50.0 Hz</p>
<p>F 4 1 5</p>	<p>[Motor rated current]</p> <p>Set parameter F 4 1 5 to the motor rated current in amperes as indicated on the motor's nameplate.</p>	<p>0.1 to 200.0 A</p>	<p>According to drive rating (2)</p>
<p>F 4 1 7</p>	<p>[Motor rated speed]</p> <p>Set parameter F 4 1 7 to the motor rated speed in rpm as indicated on the motor's nameplate.</p>	<p>100.0 to 15000 rpm</p>	<p>According to drive rating (2)</p>
<p>F 6 0 1</p> <p>(1)</p>	<p>[Motor Current Limit]</p> <p>If [Driving Scroll] (F 3 2 4) page 160 is set to [Yes] (1) the setting is replaced by 110%.</p> <div style="border: 1px solid black; padding: 10px; text-align: center;"> <p>NOTICE</p> <p>RISK OF DAMAGE TO THE MOTOR AND THE DRIVE</p> <ul style="list-style-type: none"> • Check that the motor will withstand this current. • Check that the profile mission complies with the derating curve given in the installation manual <p>Failure to follow this instruction can result in equipment damage.</p> </div> <p>Parameter F 6 0 1 can be adjusted to limit current during motoring or braking.</p> <p>Display in Current Limit Mode: When the drive goes into current limit mode, it will: Adjust the output frequency to limit the flow of motor current (down when motoring, up when braking).</p> <p>Display the letter C and the output frequency flashing on the embedded software terminal, ex: C 50</p> <p>If parameter [Unit value selection] (F 7 0 1) is set to 1 (see page 130), parameter F 6 0 1 will be adjusted in amperes. If parameter F 7 0 1 is set to 0, parameter F 6 0 1 will be adjusted as a percentage of the drive's output rated current as listed on its nameplate.</p> <p>The setting of parameter [Switch. freq. level] (F 3 0 0) (see page 95) does not change the drive's rated current for the sake of this calculation.</p> <p>Do not set parameter F 6 0 1 below the no-load current rating of the motor.</p>	<p>10 to 110% of the drive's output current rating</p>	<p>110%</p>
<p>LL</p> <p>(1)</p>	<p>[Low limit frequency] Low speed</p> <p>If [Driving Scroll] (F 3 2 4) page 160 is set to [Yes] (1) the setting is replaced by 30%.</p> <p>Parameter LL sets the minimum frequency that can be commanded to the drive by the local or remote speed reference source. See diagram above.</p>	<p>0.0 to [Upper limit freq] (vL) Hz</p>	<p>0.0 Hz</p>
<p>vL</p> <p>(1)</p>	<p>[Upper limit freq] High speed</p> <p>If [Driving Scroll] (F 3 2 4) page 160 is set to [Yes] (1) the setting is replaced by 90%.</p> <p>Parameter vL sets the maximum frequency that can be commanded to the drive by the local or remote speed reference source. The top end of its range is limited by the setting of Maximum frequency [Max frequency] (FH). See diagram above.</p>	<p>0.5 to [Max frequency] (FH) Hz</p>	<p>50 Hz</p>

(1) When (F 3 2 4) changes from [No] (0) to [Yes] (1), some of linked parameters are set to a new value.
When (F 3 2 4) changes from [Yes] (1) to [No] (0), linked parameters value are not changed.
(2) See table page 199

Code	Name / Description	Adjustment range	Factory setting
FH (1)	<p>[Max frequency] Maximum Frequency</p> <p>If [Driving Scroll] (F324) page 160 is set to [Yes] (I) the setting is replaced by 90%.</p> <p>The setting of parameter FH determines the maximum output frequency of the drive.</p> <p>FH limits the setting of parameter [Upper limit freq] (UL) (see page 92), which can be adjusted while the drive is operating. Acceleration and deceleration rates are also affected by the setting of FH, as the definition of [Acceleration time 1] (ACC) or [Deceleration time 1] (DEC) (see page 162) is the time it takes for the drive to ramp the motor up or down between zero speed and the setting of FH.</p> <p>FH can only be adjusted while the drive is stopped.</p> <div style="display: flex; justify-content: space-around;"> <div style="text-align: center;"> <p>Output frequency (Hz)</p> <p>Speed reference 0 100%</p> </div> <div style="text-align: center;"> <p>Output frequency (Hz)</p> <p>Speed reference 0 100%</p> </div> </div>	30.0 Hz to 400.0 Hz	50.0 Hz
F401 (1)	<p>[Slip Compensation]</p> <p>If [Driving Scroll] (F324) page 160 is set to [Yes] (I) the setting is replaced by 0%.</p> <p>Before adjusting parameter F401, verify that parameter [Motor rated speed] (F417) (see page 161) is set to the rated speed of the motor in rpm. Parameter F401 can be used to fine-tune the drive's slip compensation feature. Increasing the value of parameter F401 increases the drive's compensation of motor slip.</p>	0 to 150%	50 %
F402	<p>[Auto Torque Boost]</p> <p>Use parameter F402 to adjust the amount of automatic torque boost that is applied.</p> <div style="text-align: center;"> <p>Motor rated voltage (ULV)</p> <p>Output Voltage (%)</p> <p>Motor Rated Frequency (UL) Output Frequency (Hz)</p> <p>F402: Automatically adjusts the amount of torque boost.</p> </div>	0.0 to 30.0%	According to drive rating (2)
DEC (1)	<p>[Deceleration time 1]</p> <p>If [Driving Scroll] (F324) page 160 is set to [Yes] (I) the setting is replaced by 0.9 s.</p> <p>The setting of parameter DEC determines the slope of the deceleration ramp and the time it takes for the output frequency of the drive to decrease from the setting of [Max frequency] (FH) to 0 Hz.</p> <p>If parameter [Auto ramp] (AR1) is set to 1, the deceleration ramp may be increased or decreased from the setting of DEC, depending on the amount of load on the motor during ramp down. See diagram above.</p> <p>If two different deceleration rates are needed, see parameter [Deceleration time 2] (F501) on page 93.</p>	0.0 to 3200 s	According to drive rating (2)

(1) When (F324) changes from [No] (0) to [Yes] (I), some of linked parameters are set to a new value.
 When (F324) changes from [Yes] (I) to [No] (0), linked parameters value are not changed.
 (2) See table page 199

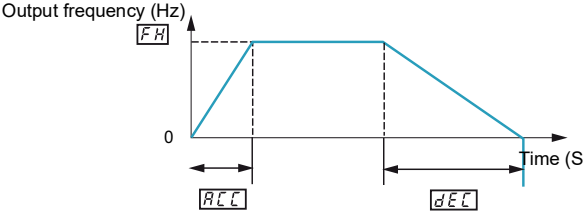
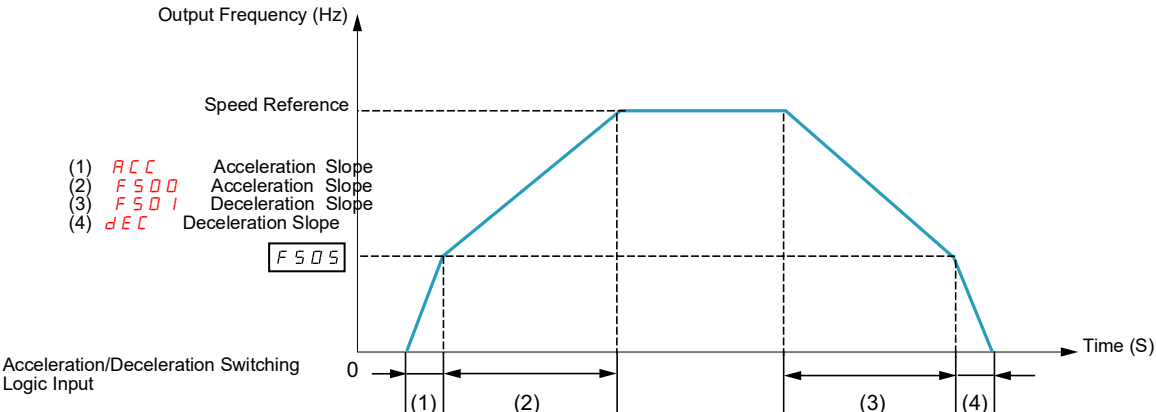
Code	Name / Description	Adjustment range	Factory setting
<p>ACC</p> <p>(1)</p>	<p>[Acceleration time 1]</p> <p>If [Driving Scroll] (<i>F 3 2 4</i>) page 160 is set to [Yes] (<i>1</i>) the setting is replaced by 0.9 s.</p> <p>The setting of parameter <i>ACC</i> determines the slope of the acceleration ramp and the time it takes for the output frequency of the drive to increase from 0 Hz to the setting of [Max frequency] (<i>F H</i>) (see page 162).</p> <p>If parameter [Auto ramp] (<i>A U 1</i>) (see page 95) is set to 1 or 2, the acceleration ramp may be increased or decreased from the setting of <i>ACC</i>, depending on the amount of load on the motor during ramp up.</p> <p>If two different acceleration rates are needed, see parameter [Acceleration time 2] (<i>F 5 0 0</i>) on page 93.</p> 	0.0 to 3200 s	According to drive rating (2)
<p>F 5 0 5</p>	<p>[Comm. ramp freq.] Acc/Dec pattern switching frequency</p> <p>If parameter <i>F 5 0 5</i> is set to a frequency greater than 0.0, the drive will use Acc/Dec pattern 1 above that frequency and Acc/Dec pattern 2 above.</p>  <p> (1) <i>ACC</i> Acceleration Slope (2) <i>F 5 0 0</i> Acceleration Slope (3) <i>F 5 0 1</i> Deceleration Slope (4) <i>DEC</i> Deceleration Slope </p> <p>Acceleration/Deceleration Switching Logic Input</p>	0.0 to [Upper limit freq] (<i>U L</i>) (Hz)	0.0 Hz
<p>F 5 0 1</p>	<p>[Deceleration time 2]</p> <p>Parameter <i>F 5 0 1</i> sets the second deceleration time. Switching between deceleration rates 1 and 2 is accomplished by means of:</p> <ul style="list-style-type: none"> - Parameter [Ramp switching] (<i>F 5 0 4</i>) (see page 95), - A particular operating frequency (see parameter [Comm. ramp freq.] (<i>F 5 0 5</i>) above), or - A logic input assigned to functions 5, 20, 21, 30, 31 – 35, or 40 (see table beginning on page 101). 	0.0 to 3200 s	20.0 s

- (1) When (*F 3 2 4*) changes from [No] (*0*) to [Yes] (*1*), some of linked parameters are set to a new value.
 When (*F 3 2 4*) changes from [Yes] (*1*) to [No] (*0*), linked parameters value are not changed.
- (2) See table page 199

F 5 0 0

[Acceleration time 2]

0.0 to 3200 s

20.0 s

Parameter **F 5 0 0** sets the second acceleration time. Switching between acceleration rates 1 and 2 is accomplished by means of:
Parameter **[Ramp switching] (F 5 0 4)** (see page 95),
A particular operating frequency (see parameter **[Comm. ramp freq.] (F 5 0 5)** above), or
A logic input assigned to functions 5, 20, 21, 30, 31 – 35, or 40 (see table beginning on page 101)

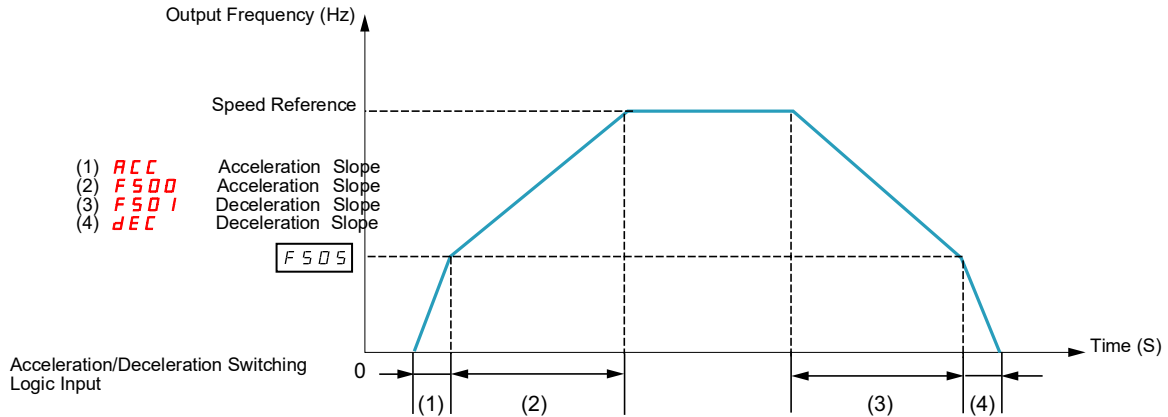

Driving Scroll (F324) (continued)

Code	Name / Description	Adjustment range	Factory setting
<p>F 4 0 0</p>	<p>[Auto-tuning drive]</p> <div style="background-color: black; color: white; text-align: center; padding: 5px; font-weight: bold; font-size: 1.2em;">⚠ ⚠ DANGER</div> <p>HAZARD OF ELECTRIC SHOCK OR ARC FLASH</p> <ul style="list-style-type: none"> • During auto-tuning, the motor operates at rated current. • Do not service the motor during auto-tuning. <p>Failure to follow these instructions will result in death or serious injury.</p> <div style="background-color: #f0f0f0; text-align: center; padding: 5px; font-weight: bold; font-size: 1.2em;">⚠ WARNING</div> <p>LOSS OF CONTROL</p> <ul style="list-style-type: none"> • It is essential that the following parameters u L u, u L, F 4 1 5 and F 4 1 7 are correctly configured before starting auto-tuning. • When one or more of these parameters have been changed after auto-tuning has been performed, F 4 0 0 will return 0 and the procedure will have to be repeated. <p>Failure to follow these instructions can result in death or serious injury.</p> <div style="text-align: center; padding: 5px; font-weight: bold; font-size: 1.2em;">NOTICE</div> <p>RISK OF DAMAGE TO THE MOTOR</p> <ul style="list-style-type: none"> • Conduct auto-tuning only after the motor has been connected and operation completely stopped. • If auto-tuning is conducted immediately after operation stops, the presence of a residual voltage may result in abnormal tuning. <p>Failure to follow these instructions can result in equipment damage.</p> <p>Auto tuning enable</p> <p>0 [Disabled]</p> <p>1 [Initialize constant]: Factory setting of [Auto Torque Boost] (F 4 0 2) for asynchronous motor. Factory setting of [Auto Torque Boost] (F 4 0 2), [Autotune L q-axis] (F 9 1 2), and [Autotune L q-axis] (F 9 1 3), and [Motor Rated Voltage] (V L V) for synchronous motor.</p> <p>2 [Tun Static]:Tune Dynamic, with driving run after the tuning. Application settings of [Auto Torque Boost] (F 4 0 2) for asynchronous motor. Application settings of [Auto Torque Boost] (F 4 0 2), [Autotune L q-axis] (F 9 1 2), and [Autotune L q-axis] (F 9 1 3) for synchronous motor.</p> <p>3 [Tun Dyn.]: Complete tune Dynamic, with driving run after the tuning. Application settings of [Auto Torque Boost] (F 4 0 2), [Autotune L q-axis] (F 9 1 2), [Autotune L q-axis] (F 9 1 3), and [Motor Rated Voltage] (V L V) for synchronous motor.</p> <p>4 [Tun Prst 1]: Tune Static, without driving run after the tuning. Application settings of [Auto Torque Boost] (F 4 0 2) for asynchronous motor. Application settings of [Auto Torque Boost] (F 4 0 2), [Autotune L q-axis] (F 9 1 2), and [Autotune L q-axis] (F 9 1 3) for synchronous motor.</p> <p>5 [Tun Prst 2]: Complete tune Static, without driving run after the tuning. Application settings of [Auto Torque Boost] (F 4 0 2), [Autotune L q-axis] (F 9 1 2), and [Autotune L q-axis] (F 9 1 3), and [Motor Rated Voltage] (V L V) for synchronous motor.</p> <p>Parameter F 4 0 0 is reset to "0" after the auto tuning is performed</p>	-	0
<p>F 4 5 8</p>	<p>[Current loop gain]</p> <p>Parameter F 4 5 8 is set to the response gain of current loop</p> <p>Note: Contact Schneider electric product support to confirm the modification of this parameter.</p>	0...100 Hz	0 Hz

F 4 1 8	[Frequency loop gain]		1 to 150	40
<p>Parameters F 4 1 8 and [Freq. loop stability] (F 4 1 9) reduce the speed of the drive's response to a change in speed command. The factory setting of these two parameters assumes that the inertia of the load is three times as large as that of the motor shaft. Adjust these two parameters if the factory setting is not appropriate for the application.</p> <p>Note: It is possible for the drive's output frequency to exceed its upper limit (parameter [Max frequency] (F H)) if the acceleration parameter (A C C or F 5 0 7) is set to its minimum value.</p> <p>Increasing the setting of parameter F 4 1 8 reduces the drive's response time to changes in the speed reference.</p>				
F 4 1 9	[Freq. loop stability]	Frequency loop stability	1 to 100	20
<p>Increasing the setting of parameter F 4 1 9 further reduces the drive's response to changes in the speed reference.</p>				
F 4 9 5	[Motor voltage coef.]	Maximum voltage adjustment coefficient	90 to 120%	104%
<p>Use parameter F 4 9 5 to limit the drive's maximum output voltage. Increasing this setting increases torque when the motor is operated above its rated frequency, but may also cause motor vibration. Do not increase the value of F 4 9 5 if motor vibrations occur.</p>				
F 9 1 5	[PM mode selection]	PM control mode selection	-	3
0	[0]: basic control			
1	[1]: control type 1 (for IPM)			
2	[2]: control type 2 (for IPM)			
3	[3]: control type 3 (for IPM / SPM)			
4	[4]: control type 4 (for IPM / SPM)			
<p>For more details see the chapter Motor Control Parameters "F915" on page 84</p>				
F 9 1 2	[Autotune L q-axis]	Q-axis self-inductance	0.01 to 650 mH	10
<p>Axis "q" stator inductance in mH The setting is replaced by the result of the auto-tuning operation, if it has been performed.</p>				
F 9 1 3	[Autotune L d-axis]	D-axis self-inductance	0.01 to 650 mH	10
<p>Axis "d" stator inductance in mH The setting is replaced by the result of the auto-tuning operation, if it has been performed.</p>				
F 9 1 6	[PM Align cur. Level]	Stabilization at the starting and low speed (for PM)	0 to 100 %	25 %
<p>It might be able to stabilize the motor rotation behavior by the current in D axis at no load when starting or low-speed</p> <p>For a complete description, see page 85.</p>				
F 9 2 1	[Init. Pos. Current]	Current for initial position estimation	10 to 150	100 %
<p>During the auto-tuning for d-axis / q-axis inductance, the maximum current level can be adjusted by this parameter setting.</p>				
F 4 2 0	[Torque Boost Coef]	Compensation coefficient of torque boost	0 to 200%	90 %
<p>If synchronous or asynchronous motor is used F 4 2 0 [Torque Boost Coef] is set to 90%.</p> <p>Note: If E - 2 0 [Excess torque boost flt] trip occurs at the start, it is recommended to be decreased the setting of F 4 2 0</p>				

<p>F 130</p> <p>(1)</p>	<p>[RY Relay Function 1] RYA-RYC Relay Function</p> <p>If [Driving Scroll] (F 324) page 160 is set to [Yes] (1) the setting is replaced by [disable oil injection in high-speed positive logic] (70)</p> <p>For a complete description of the various functions assignable to the RYA-RYC relay, see page 108. The RYA-RYC relay can have a secondary assignment with programmed selection logic. See parameters [RY Relay Function 2] (F 137) and [RY logic select.] (F 139) on page 124 for more detail.</p> <p>F130 - RY Behaviour</p> <div style="display: flex; justify-content: space-around;"> <div style="border: 1px solid black; padding: 2px;">F 101</div> + <div style="border: 1px solid black; padding: 2px;">F 102</div> <div style="border: 1px solid black; padding: 2px;">F 101</div> <div style="border: 1px solid black; padding: 2px;">F 101</div> - <div style="border: 1px solid black; padding: 2px;">F 102</div> </div>	<p>0 to 69, 254, 255</p>	<p>4</p>
<p>F 132</p> <p>(1)</p>	<p>[FL Relay Function] Delay for RYA-RYC Relay</p> <p>If [Driving Scroll] (F 324) page 160 is set to [Yes] (1) the setting is replaced by [Inv F101 sp reach] (9)</p> <p>This parameter introduces a delay on RYA-RYC output signal relay see page 108.</p> <p>F132 - FL Behaviour</p> <div style="display: flex; justify-content: space-around;"> <div style="border: 1px solid black; padding: 2px;">F 101</div> + <div style="border: 1px solid black; padding: 2px;">F 102</div> <div style="border: 1px solid black; padding: 2px;">F 101</div> <div style="border: 1px solid black; padding: 2px;">F 101</div> - <div style="border: 1px solid black; padding: 2px;">F 102</div> </div>	<p>0 to 69, 254, 255</p>	<p>11</p>

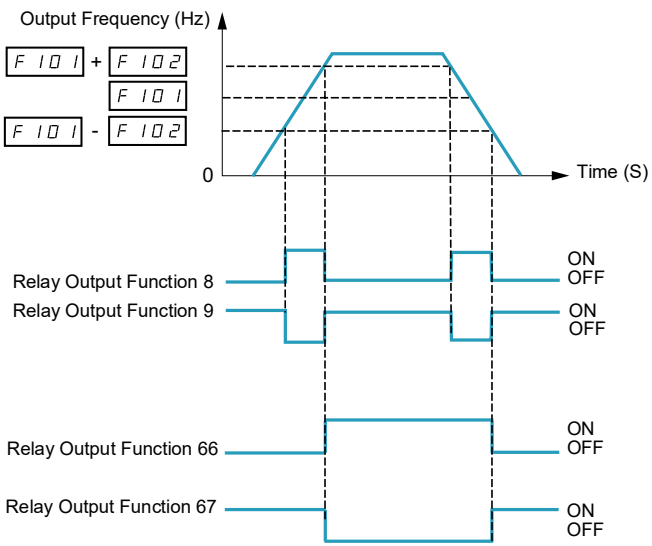
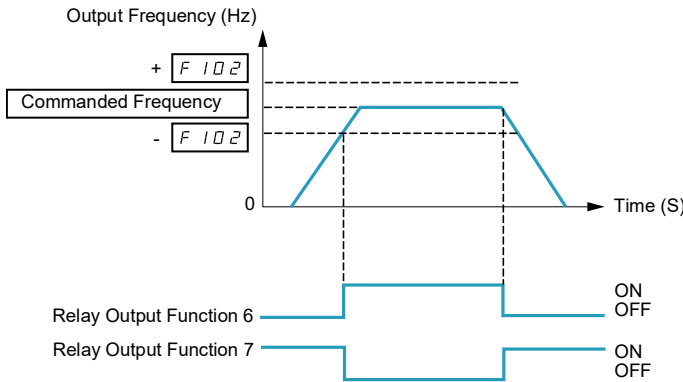
<p>F 101</p> <p>(1)</p>	<p>[Freq. 2 reached] Relay Output – Frequency Level 2 Attained</p> <p>If [Driving Scroll] (F 324) page 160 is set to [Yes] (1) the setting is replaced by 65 Hz.</p> <p>The frequency set by parameter F 101 +/- the [Freq.2 bandw.] (F 102) detection band is the threshold level for relay output functions 8 and 9 and the hysteresis for relay output functions 66 and 67 (see page 113).</p> 	<p>0.0 to [Max frequency] (F H) Hz</p>	<p>0.0 Hz</p>
<p>F 102</p> <p>(1)</p>	<p>[Freq.2 bandw.] Frequency Attained Detection Band</p> <p>If [Driving Scroll] (F 324) page 160 is set to [Yes] (1) the setting is replaced by 0.65 Hz.</p> <p>Parameter F 102 determines the bandwidth around the [Freq.2 reached] (F 101) frequency (see diagram above) and the commanded frequency (see diagram below) driving relay output functions 6 through 9 (see page 101).</p> 	<p>0.0 to [Max frequency] (F H) Hz</p>	<p>2.5 Hz</p>
<p>F 113</p> <p>(1)</p>	<p>[LI RES selection] RES Logic Input Function (2)</p> <p>If [Driving Scroll] (F 324) page 160 is set to [Yes] (1) the setting is replaced by [Inverse Run permis.] (54).</p> <p>The setting of parameter F 113 determines the control function of logic input terminal RES.</p>	<p>0 to 73</p>	<p>10</p>

- (1) When (F 324) changes from [No] (0) to [Yes] (1), some of linked parameters are set to a new value.
 When (F 324) changes from [Yes] (1) to [No] (0), linked parameters value are not changed
- (2) See table on 101 for a complete list of RES logic inputs assignment

<p>F 3 0 3</p> <p>I to I 0</p>	<p>[Number auto reset]</p> <div style="text-align: right; border: 1px solid black; width: 50px; margin: 0 auto; padding: 2px;">0</div> <div style="background-color: black; color: white; text-align: center; padding: 5px; margin: 10px 0;"> DANGER </div> <p>UNINTENDED EQUIPMENT OPERATION</p> <ul style="list-style-type: none"> ● The automatic restart can only be used on machines or installations which do not pose any danger to either personnel or equipment. ● If the automatic restart is activated, the fault relay will only indicate a fault has been detected once the time-out period for the restart sequence has expired. ● The equipment must be used in compliance with national and regional safety regulations <p>Failure to follow these instructions will result in death or serious injury.</p> <p>Disabled. Number of clear attempts.</p> <p>F 3 0 3 is common and single for all functions The fault detection codes, which permit this function, are listed on page 135.</p>
---	---

Pre-start Scroll (F325)

This function is to help protect the compressor. The Drive must reach [Low limit Freq] (LL) within 2 s max. If not, FreeWheel stop the drive and do an automatic restart after a preset delay [Pre-start delay] (F 3 2 9). Once [Low limit Freq] (LL) speed is reached in less than 2 s [LL speed time] (F 3 2 8) the motor should run at [Pre-Start speed] (F 3 2 7) for a [Pre-Start time] (F 3 2 6) before taking into account the reference frequency.

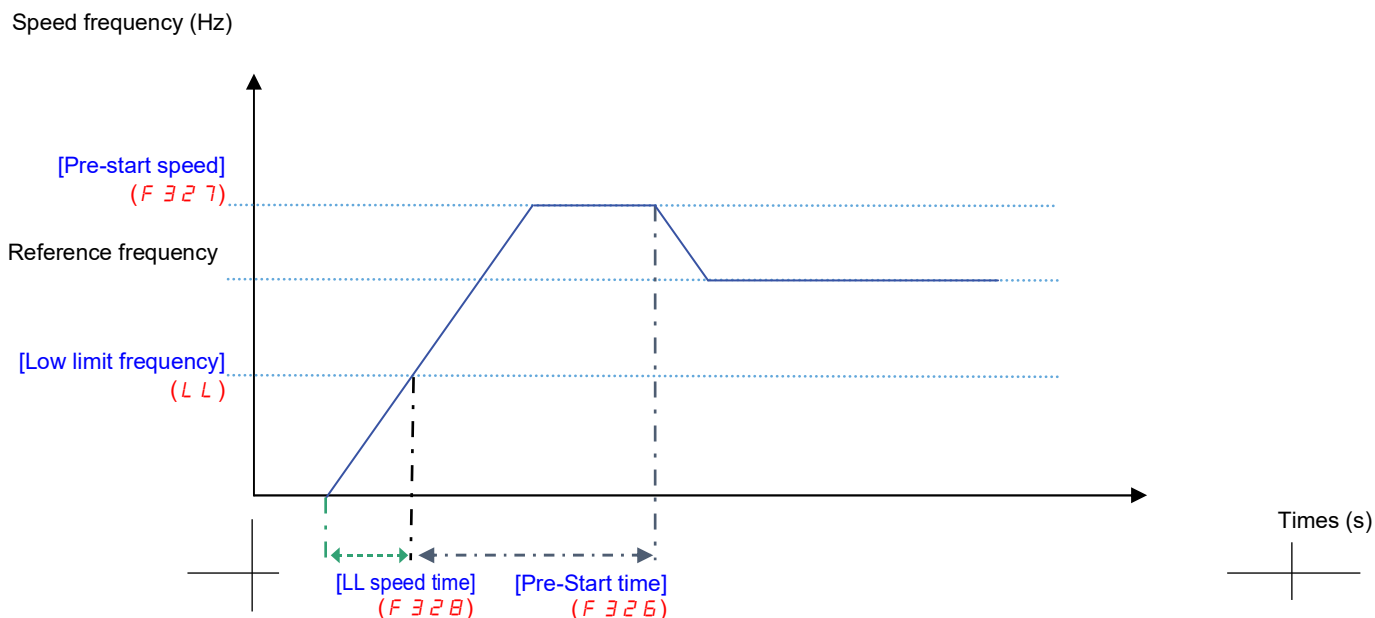

If the [Pre-Start speed] (F 3 2 7) is never reach, the amount of attempt should be limited at 10, and the alarm code [Auto reset] (r t r 4) should be raised (see alarm codes page 184). After activating this function, [Pre-start Scroll] (F 2 3 5) must be achieved at every run order.

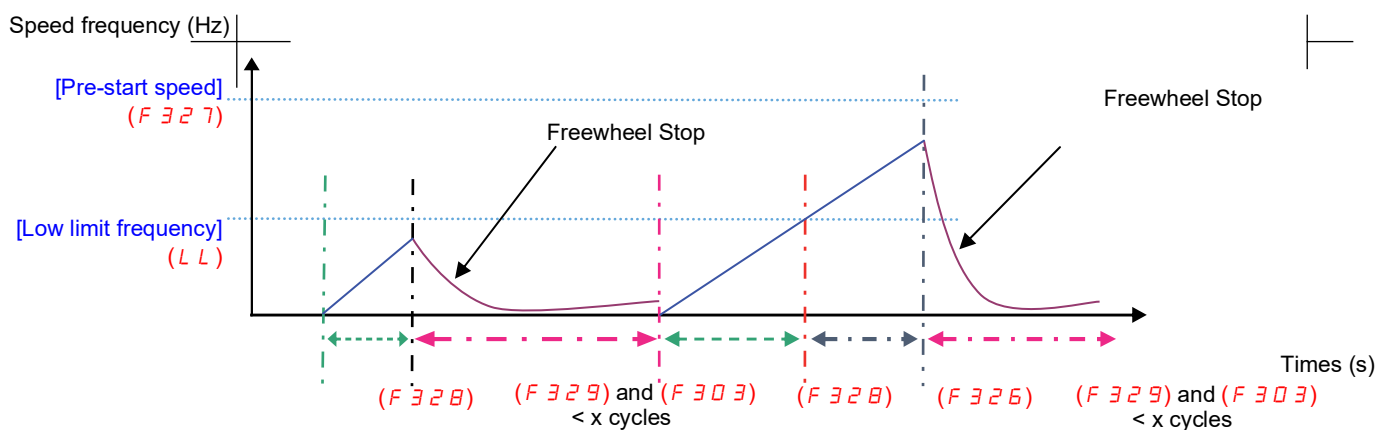

Code	Name / Description	Adjustment range	Factory setting
F 3 2 5	[Pre-start Scroll] Scroll Compressor Pre-start Management	-	0
0 1	At every Run Order the Drive must reach a preset Low Limit Frequency within a preset time and a limited number of attempts in order to avoid mechanical issues. [No] [Yes]		
F 3 2 6	[Pre-Start time] Time to reach the pre-start speed Time during the motor turn to the pre-start speed	0...6000 s	10 s

<p>F 3 2 7</p>	<p>[Pre-Start speed] Speed to reach within the pre-start cycle</p>	<p>0.0 Hz to [Upper limit freq] (u L)</p>	<p>50 Hz</p>
<p>F 3 2 8</p>	<p>[LL speed time] Time to reach LL Freq on pre-start order Time which needs to be respected for reaching the low limit frequency. If the motor does not reach the [Low limit frequency] (L L) during this time the motor must stop.</p>	<p>0...10 s</p>	<p>2 s</p>
<p>F 3 2 9</p>	<p>[Pre-start delay] Delay between two pre-start cycles</p>	<p>0...120 s</p>	<p>3 s</p>

Std Oiling Cycle (F330)

This function helps to prevent the damage to the installation by lubricating it after a period of running. The drive manages to re-oil the Scroll pump by running the (F330 = [Yes] (1)) motor at the optimal [Std Oiling Speed] (F331) for a settable [Std Oiling Time] (F332). The [Std Oiling Speed] (F331) must be reached at least one time within the [Std Oil. Cycle Frq.] (F333) of run order.

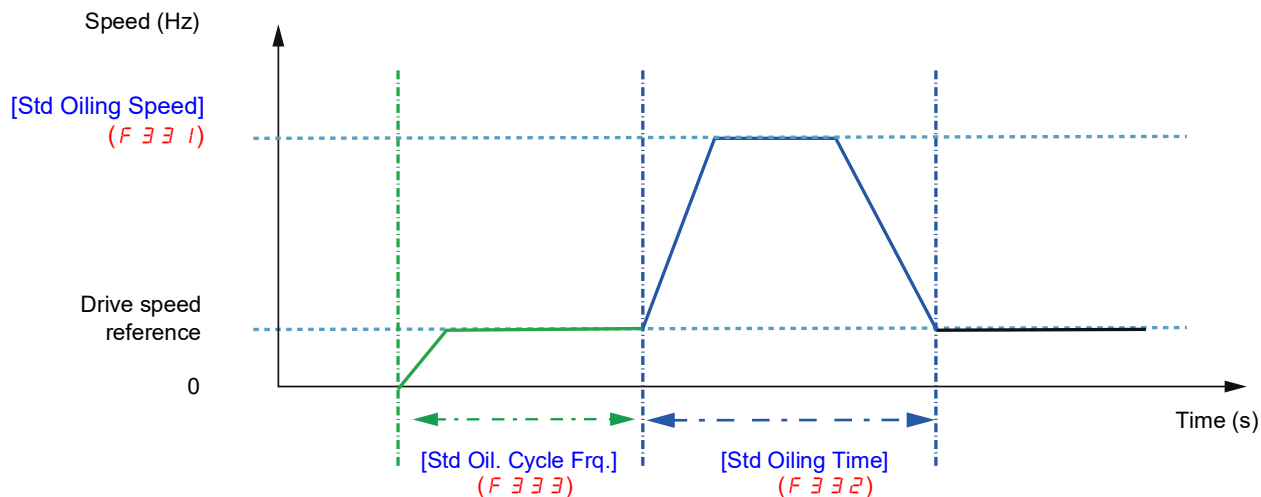

Code	Name / Description	Adjustment range	Factory setting
F330	[Std Oiling Cycle] Periodic Oiling Cycle management After a preset period of service and/or a preset time of running at a low speed, the drive must manage an oiling boost cycle by running at a preset oiling speed during a preset oiling time. 0 [No] 1 [Yes]	-	0
F331	[Std Oiling Speed] Oiling Speed for Std Oiling Cycle Oiling is done at this frequency.	0 Hz to (UL) [Upper limit freq]	70 Hz
F332	[Std Oiling Time] Time to maintain Oiling Speed in Std Cycle Time to maintain oiling speed in standard cycle	0 s to 6000 s	30 s
F333	[Std Oil. Cycle Frq.] Frequency (time) of Standard Oiling Cycle Time during the motor which turn without lubrication since the first Run order.	0 to 24 Hours (of run oder)	24 hrs

Low Speed Oiling (F334)

This function helps to protect the installation of low lubrication that occurs at low speed. The [Std Oiling Speed] (F 3 3 1) must be reached during a time [Oiling Time at LLS] (F 3 3 7) if the motor speed stayed under a [LL Speed for Oiling] (F 3 3 5) during a cycle limit [LLS Time for Oiling] (F 3 3 6).

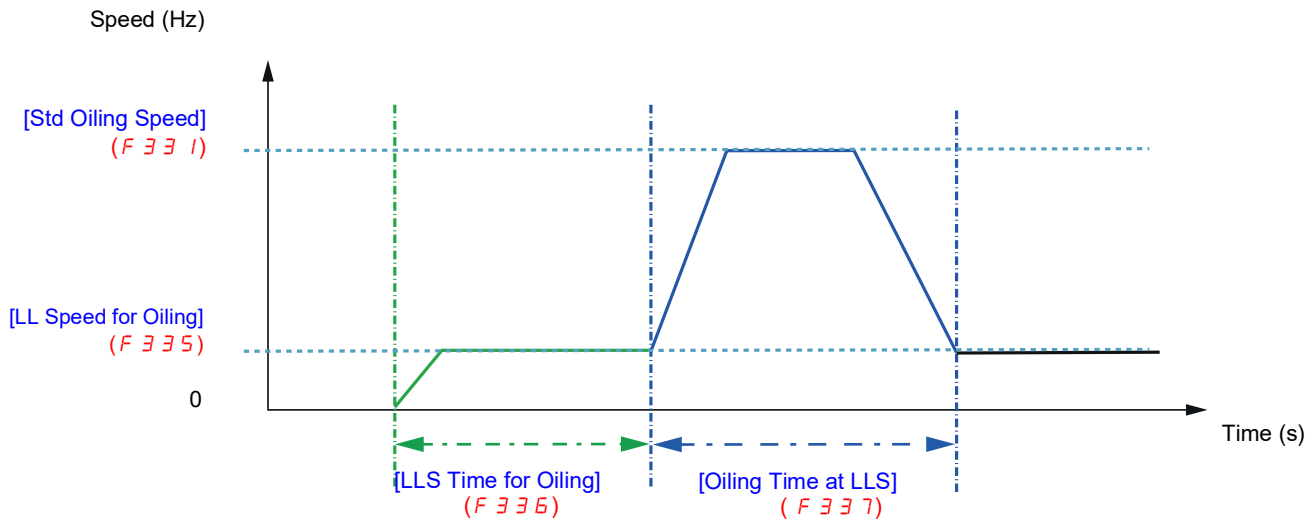

Code	Name / Description	Adjustment range	Factory setting
F 3 3 4	[Low Speed Oiling] Oiling management for low speed running A preset oiling speed must be reached during a preset time every time the motor stayed under a preset speed during a preset time to compensate a too low lubrication due to low speed. 0 [No] 1 [Yes]	-	0
F 3 3 1	[Std Oiling Speed] Oiling Speed for Std Oiling Cycle Oiling Speed for Standard Oiling Cycle.	0 Hz to (LL) [Upper limit freq]	70 Hz
F 3 3 5	[LL Speed for Oiling] Low speed threshold to start Oiling control. If the system never reach it after time [LLS Time for Oiling] (F 3 3 6) the system will go in lubrication.	0 Hz to (LL) [Upper limit freq]	50 Hz
F 3 3 6	[LLS Time for Oiling] Time during the motor turn under the threshold of [LL Speed for Oiling] (F 3 3 5).	0...360 minutes	60 minutes
F 3 3 7	[Oiling Time at LLS] Time to maintain oiling injection in the installation.	0...6000 s	30 s

Scroll Protection (F338)

This function is active only out of the acceleration phase to help protect the Scroll pump about overloading and cavitations effect, if the motor current limit is over passed and if the speed is under the [Cavitation Frq.] (F339) the drive will stop in Freewheel and the alarm signal will be displayed [Cavitation Error] (CAFF).

Code	Name / Description	Adjustment range	Factory setting
F 3 3 8	[Scroll Protection] Avoid overloading or cavitation effects Scroll compressor protection against the effects of overload and cavitation If Fire function mode (53) is activated and F 3 3 8 = (1), [Cavitation Error] (CAFF) alarm signal is inhibited, see Logic input Functions page 53 0 [No] 1 [Yes]	-	0
F 3 3 9	[Cavitation Frq.] Cavitation Frequency Threshold.	[Low limit frequency] (LL) to [Upper limit freq] (UL)	30 Hz

Discharge gas (F349)

This function enables to help to protect the installation avoiding high temperature or high pressure, the speed will automatically reduced the speed or stop the Scroll pump depending on temperature level [High Thd] (F 3 5 0) and [High high Thd] (F 3 5 3).

The time [Re-Start Delay] (F 3 5 4) before automatic restart (see [Number auto reset] (F 3 0 3) page 169) is settable and the number of maximum attempt is limited to 10. The restart will come [Re-Start Delay] (F 3 5 4) after the temperature gets under \leq [High high Thd] (F 3 5 3).

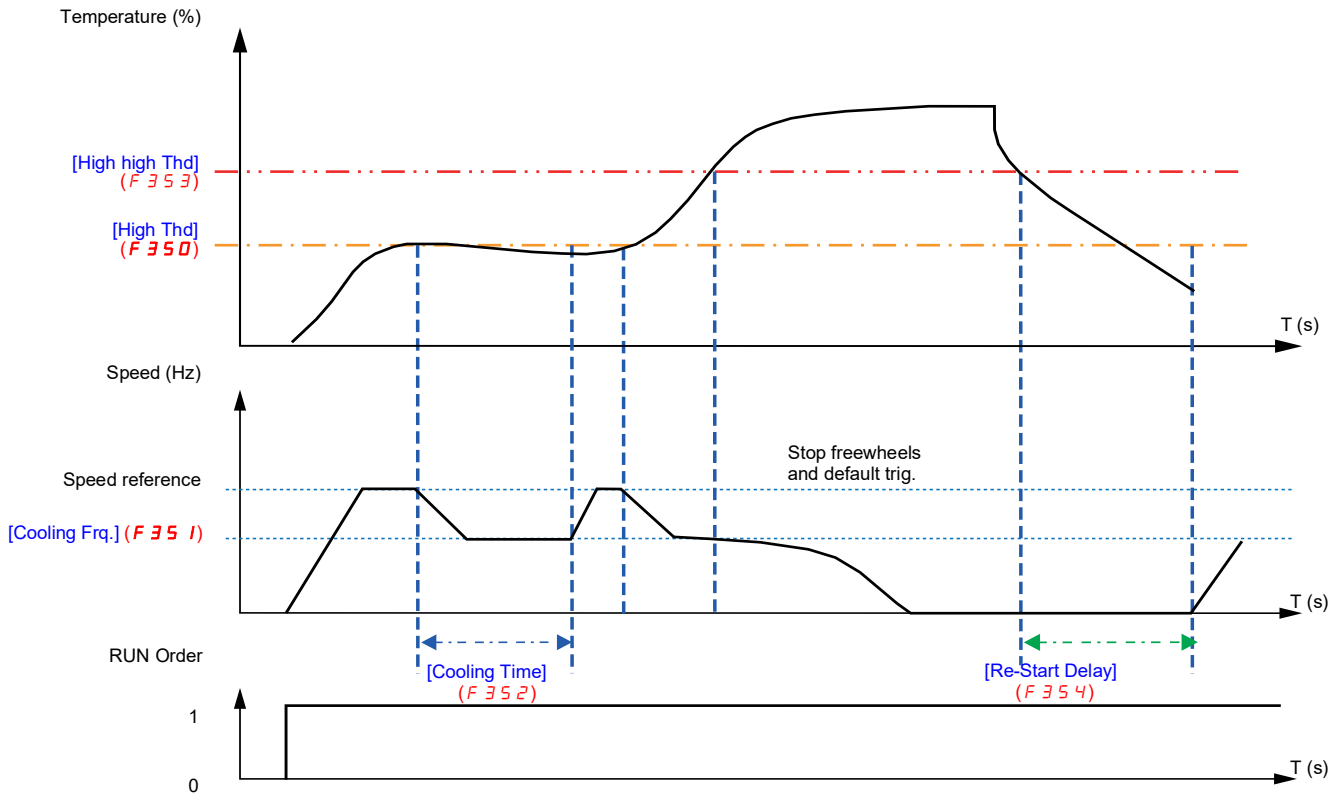

Code	Name / Description	Adjustment range	Factory setting
F 3 4 9	[Discharge gas] Avoid high temp. or pressure on sensor input This function helps to protect the installation avoiding high temperature or high pressure in the refrigerant loop. 0 [No] Function unactive 1 [VIA] Function is active and uses analog input VIA [Ref source VIA] 2 [VIB] Function is active and uses analog input VIB: [Ref source VIB]	-	0
F 3 5 0	[High Thd] High Process Threshold Note: 100% means analog input ports VIA or VIB applied full scale value.	0 - 100	65 %
F 3 5 1	[Cooling Frq.] Cooling system Frequency.	[Low limit frequency] (L L) to [Upper limit freq] (U L)	50 Hz
F 3 5 2	[Cooling Time] Time to maintain cooling system frequency.	0 - 30	3 minutes
F 3 5 3	[High high Thd] High high Process Threshold. Note: 100% means analog input ports VIA or VIB applied full scale value.	0 - 100	70 %
F 3 5 4	[Re-Start Delay] Delay before restart after emergency stop.	0...30 minutes	5 minutes

Crankcase heating (F355)

Replace crankcase heaters by using a current injection in motor to generate resistance heating.

Note: Before using the Function [Crankcase heating] (F 3 5 5), to stop the current injection you should assign a logic input to Freewheel stop, you can also stop the injection by a power off.

Code	Name / Description	Adjustment range	Factory setting
F 3 5 5 0 1	[Crankcase heating] Keep the system warm after motor stopped Heating by current injection in the motor in order to prevent the emission of gas due to the condensation of the refrigerant into the compressor.	-	0
F 2 5 0 (1)	[DC brake start freq.] If [Driving Scroll] (F 3 2 4) page 160 is set to [Yes] (1) the setting is replaced by 0.0 Hz.	0.0 Hz to [Max frequency] (F H)	0.0 Hz
<div style="border: 1px solid black; padding: 5px; margin: 10px auto; width: 80%;"> <p style="text-align: center;">⚠ WARNING</p> <p>NO HOLDING TORQUE</p> <ul style="list-style-type: none"> ● DC injection braking does not provide holding torque at zero speed. ● DC injection braking does not work when there is a loss of power or when the drive detects a fault. ● When necessary, use a separate brake to maintain torque levels. <p>Failure to follow these instructions can result in death, serious injury, or equipment damage.</p> </div> <p>When stopping the motor, the drive will apply DC injection braking once the output frequency drops below the level set by parameter F 2 5 0.</p>			
F 2 5 1 (1)	[DC braking current] If [Driving Scroll] (F 3 2 4) page 160 is set to [Yes] (1) the setting is replaced by 10%.	0 to 100 %	50%
<div style="border: 1px solid black; padding: 5px; margin: 10px auto; width: 80%;"> <p style="text-align: center;">NOTICE</p> <p>RISK OF DAMAGE TO THE MOTOR</p> <p>Check that the motor will withstand this current without overheating.</p> <p>Failure to follow this instruction can result in equipment damage.</p> </div> <p>Parameter F 2 5 1 sets the level of current applied to the motor during DC injection braking. The displayed value, percent or amperes, is set by parameter [Unit value selection] (F 7 0 1) (see page 130). During DC injection braking, the drive's overload protection sensitivity increases. The drive automatically lowers the applied DC current to avoid an overload detected fault.</p>			

(1) When (F 3 2 4) changes from [No] (0) to [Yes] (1), some of linked parameters are set to a new value.
When (F 3 2 4) changes from [Yes] (1) to [No] (0), linked parameters value are not changed.

Diagnostics and troubleshooting

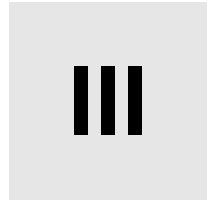

What's in this Part?

This part contains the following chapters:

Chapter	Chapter Name	Page
14	Diagnostics and troubleshooting	179

Diagnostics and troubleshooting

15

What's in this Chapter?

This chapter contains the following topics:

Topic	Page
Detected fault conditions	180
Alarm Conditions	184
Pre-alarm Conditions	186
Clearing the detected fault	187

Detected fault conditions

Refer to tables on pages hereafter to diagnose and solve troubles when there is a fault detection, or when an alarm, or pre-alarm condition occurs.

If the trouble cannot be solved by the actions described in the tables, contact your Schneider Electric representative.

DANGER

HAZARD OF ELECTRIC SHOCK, EXPLOSION OR ARC FLASH

- Read and understand the instructions in «Before you begin» chapter, before performing the procedure in this section.

Failure to follow these instructions will result in death or serious injury.

Alarm Codes

Code	Name	Possible causes	Remedies
C A P F	[Cavitation Error]	<ul style="list-style-type: none"> • Loss of speed due to overload or / and too much torque. 	<ul style="list-style-type: none"> • Reduce the load
C F 12	[Download transfer fault]	<ul style="list-style-type: none"> • Invalid configuration. The configuration loaded in the drive via the bus or communication network is inconsistent. • Transfer using PC soft has not been successful due to rating differences (for example upload of an ATV212●●●N4 configuration to an ATV212●●●M3) 	<ul style="list-style-type: none"> • Check the configuration loaded previously. • Load a compatible configuration. • To perform download, uncheck "Display communication error" (in Tool / Environnement option / Startup/Comm.)
E - 18	[VIA signal fault]	<ul style="list-style-type: none"> • The VIA analog signal is below the level set by parameter F 6 3 3. 	<ul style="list-style-type: none"> • Check the signal at VIA and rectify the cause of the signal loss. • Verify that parameter F 6 3 3 is set correctly.
E - 19	[CPU communications err.]	<ul style="list-style-type: none"> • Communication error between control CPUs 	<ul style="list-style-type: none"> • Check the environment (electromagnetic Compatibility) • Turn off and restart product. • Reduce the switching frequency [Switch. freq. level] (F 3 0 0) to below 12 kHz. • Contact Schneider Electric product support.
E - 20	[Excess torque boost ft]	<ul style="list-style-type: none"> • Torque boost parameter [Auto Torque Boost] (F 4 0 2) is set too high. • The motor impedance is too low. <p>During deceleration when [Mot cont. mode sel.] (P 1) = (1) [Quadr. U/F] with 3 conditions:</p> <ul style="list-style-type: none"> - Processing for stop - Load current value > 88% x [Motor Current Limitation] (F 6 0 1) - Too slow deceleration, [Max frequency] (F H)/[Deceleration time 1] (d E C) x 2 msec < 0.01Hz 	<ul style="list-style-type: none"> • Repeat the Auto-tuning drive and reduce [Auto Torque Boost] (F 4 0 2). • Set [Auto ramp] (R u 1) = (0) [Disabled] • Decrease the deceleration ramp with [Deceleration time 2] (F 5 0 1) and [Comm. ramp freq.] (F 5 0 5).
E - 21	[CPU error 2 fault]	<ul style="list-style-type: none"> • The control board CPU is inoperable. 	<ul style="list-style-type: none"> • Contact Schneider Electric to repair the drive.
E - 38	[EEPROM pwr incompat.]	<ul style="list-style-type: none"> • Eeprom power incompatible. • Product hardware detected fault. 	<ul style="list-style-type: none"> • Contact Schneider Electric to repair the drive.
E - 39	[InitPos Det]	<ul style="list-style-type: none"> • An Error is detected at the starting: The measured current at initial position detection at the starting is too small or large according to the inductance of motor or output phase loss. 	<ul style="list-style-type: none"> • Check the motor phases and the maximum current allowed by the drive. • To check that the inductance of motor is too small or too large.
E E P 1	[EEPROM error 1 fault]	<ul style="list-style-type: none"> • A data writing error has occurred. 	<ul style="list-style-type: none"> • Cycle power to clear the detected fault.
E E P 2	[EEPROM error 2 fault]	<ul style="list-style-type: none"> • Power was removed from the drive during a parameter reset operation resulting in a data writing error. • The measured current at initial position detection at the auto-tuning is too small or large according to the inductance of motor or output phase loss 	<ul style="list-style-type: none"> • Cycle power to clear the detected fault and try the parameter reset operation again. • If the detected fault does not clear, contact Schneider Electric to repair the drive.

Code	Name	Possible causes	Remedies
E E P 3	[EEPROM error 3 fault]	<ul style="list-style-type: none"> A data reading error has occurred. 	<ul style="list-style-type: none"> Cycle power to clear the detected fault.
E F 2	[Ground fault]	<ul style="list-style-type: none"> Ground fault in motor or motor cables 	<ul style="list-style-type: none"> Check the motor and motor cables for ground faults.
E P H 0	[Output phase loss fault]	<ul style="list-style-type: none"> Loss of one or more output phases 	<ul style="list-style-type: none"> Determine the cause of the missing output phase (such as a bad connection, an output disconnect, or an open winding in the motor) and clear it. Check parameter F 6 0 5.
E P H 1	[Input phase loss fault]	<ul style="list-style-type: none"> Loss of one input phase 	<ul style="list-style-type: none"> Determine the cause of the missing input phase and clear it. Check parameter F 6 0 8.
E P L F	[Threshold Error]	<ul style="list-style-type: none"> Condition for overheating reached, exceeded Threshold F 3 5 3 	<ul style="list-style-type: none"> Check the system.
E r r 1	[Speed ref. error fault]	<ul style="list-style-type: none"> Parameters F 2 0 2, F 2 0 3, F 2 1 0, or F 2 1 2 are set improperly. 	<ul style="list-style-type: none"> Set the parameters to the correct settings.
E r r 2	[RAM fault]	<ul style="list-style-type: none"> The control board RAM is inoperable. 	<ul style="list-style-type: none"> Contact Schneider Electric to repair the drive.
E r r 3	[ROM fault]	<ul style="list-style-type: none"> The control board ROM is inoperable. 	<ul style="list-style-type: none"> Contact Schneider Electric to repair the drive.
E r r 4	[CPU fault 1]	<ul style="list-style-type: none"> The control board CPU is inoperable. 	<ul style="list-style-type: none"> Contact Schneider Electric to repair the drive.
E r r 5	[Com RJ45 fault]	<ul style="list-style-type: none"> Serial communication error 	<ul style="list-style-type: none"> Check network control devices and cables. Check the setting of the communication timeout parameter, F 8 0 3. Check the remote graphic display option cable. Check the setting of F 8 2 9 parameters.
E r r 7	[Current sensor fault]	<ul style="list-style-type: none"> A motor current sensor is inoperable. 	<ul style="list-style-type: none"> Replace the drive.
E r r 8	[Network error fault]	<ul style="list-style-type: none"> Network communication error 	<ul style="list-style-type: none"> Check the network control devices and cables.
E r r 9	[Remote keypad fault]	<ul style="list-style-type: none"> Graphic display option cable disconnected 	<ul style="list-style-type: none"> Check the RJ45 cable.
E t n 1	[Auto-tuning fault]	<ul style="list-style-type: none"> Parameters F 4 0 1 to F 4 9 4 are incorrectly set. The motor is too large for the drive. The motor cable gauge is too small. The motor is still rotating at the start of the auto-tune. The drive is not powering a 3-phase induction motor. The measured current at initial position detection at the auto-tuning is too small or large according to the inductance of motor or output phase loss 	<ul style="list-style-type: none"> Set parameters F 4 0 1–F 4 9 4 correctly. Use a larger drive. Use a larger gauge motor cable. Verify that the motor is stopped before starting an auto-tune. Use the drive to power only a 3-phase induction motor.
E L Y P	[Drive fault]	<ul style="list-style-type: none"> The main control board is inoperable. 	<ul style="list-style-type: none"> Set parameter [Parameter reset] (E Y P) to 6. If this does not clear the detected error, replace the drive.
F d 1	[Closed damper 1 fault]	<ul style="list-style-type: none"> Damper is locked in closed position. 	<ul style="list-style-type: none"> Set [Damper flt behavior] (F 5 8 3) to 0. Check the FL relay connection (F L A/F L B). Check the relay configuration (F 1 3 0/F 1 3 2).
F d 2	[Closed damper 2 fault]	<ul style="list-style-type: none"> Damper blocked open or soldered. 	<ul style="list-style-type: none"> Set [Damper fdb type] (F 5 8 0) to 0 or 1. Check the FL relay connection (F L A/F L B). Check the relay configuration (F 1 3 0/F 1 3 2).
n 0 2 0	[Total input power]	<ul style="list-style-type: none"> The accumulated input power value is more than 999.999 kWh. 	<ul style="list-style-type: none"> Clear the accumulated input power value using logic input function 51, or parameter F 7 4 8.

Code	Name	Possible causes	Remedies
oC1	[Overcurrent acceleration]	<ul style="list-style-type: none"> The acceleration time is too short. The setting of parameter [Mot cont. mode sel.] (Pt) is incorrect. The drive is starting into a rotating load. The drive is powering a low impedance motor. Ground fault 	<ul style="list-style-type: none"> Increase the acceleration time parameters (ACC or F500). Select the correct setting for parameter [Mot cont. mode sel.] (Pt). Enable catch on the fly, parameter F301. Adjust the switching frequency parameter F300. Set parameter F316 to 1 or 3.
oC1P	[SC or ground fault acc.]	<ul style="list-style-type: none"> Short circuit or ground fault during acceleration 	<ul style="list-style-type: none"> Using a 1000 V testing tool megger, check the motor and motor cables for ground faults.
oC2	[Overcurrent deceleration]	<ul style="list-style-type: none"> The deceleration time is too short. Ground fault 	<ul style="list-style-type: none"> Increase the deceleration time parameters (DEC or F501). Set parameter F316 to 1 or 3.
oC2P	[SC or ground fault dec.]	<ul style="list-style-type: none"> Short circuit or ground fault during deceleration 	<ul style="list-style-type: none"> Using a 1000 V megger, check the motor and motor cables for ground faults.
oC3	[Overcurrent cont. speed]	<ul style="list-style-type: none"> Abrupt fluctuations in load Abnormal load condition 	<ul style="list-style-type: none"> Reduce the load fluctuations. Check the load. Set parameter F316 to 1 or 3.
oC3P	[SC/ground flt cont. spd]	<ul style="list-style-type: none"> Short circuit or ground fault during constant speed operation The drive cooling fan is not working. 	<ul style="list-style-type: none"> Using a 1000 V megger, check the motor and motor cables for ground faults. Check the fan operation
oCA	[SC inverter at start]	<ul style="list-style-type: none"> Ground fault 	<ul style="list-style-type: none"> Using a 1000 V megger, check the motor and motor cables for ground faults.
oCL	[SC mot. cable at start]	<ul style="list-style-type: none"> Phase to phase output short circuit The motor impedance is too low. 	<ul style="list-style-type: none"> Using a 1000 V megger, check the motor and motor cables for ground faults.
oH	[Drive overtemperature]	<ul style="list-style-type: none"> The drive cooling fan is not working. The ambient temperature is too high. An enclosure air vent is blocked. A heat source is too close to the drive. The drive heatsink temperature sensor is malfunctioning. 	<ul style="list-style-type: none"> Restart operation by resetting the drive detected fault after cool-off. Decrease the ambient temperature by increasing the free space around the drive and removing any heat generating source from the proximity of the drive. Check the fan operation
oH2	[PTC overheating]	<ul style="list-style-type: none"> The external PTC embedded in the motor windings indicates a motor overtemperature condition. 	<ul style="list-style-type: none"> Correct the motor overload condition. Check the PTC for correct operation.
oL1	[Drive overload]	<ul style="list-style-type: none"> The acceleration time is too short. The DC injection current level is too high. The setting of parameter [Mot cont. mode sel.] (Pt) is incorrect. The drive is starting into a rotating load. The load is too large. 	<ul style="list-style-type: none"> Increase the acceleration time parameters (ACC or F500). Reduce the setting of parameters F251 and/or F252. Select the correct setting for parameter [Mot cont. mode sel.] (Pt). Enable catch on the fly, parameter F301. Set parameter F302 to 2. Use a drive with a higher power rating.
oL2	[Motor overload]	<ul style="list-style-type: none"> The setting of parameter [Mot cont. mode sel.] (Pt) is incorrect. The motor is jammed. Low-speed operation is performed continuously Excessive load is applied to the motor. 	<ul style="list-style-type: none"> Select the correct setting for parameter [Mot cont. mode sel.] (Pt). Check the load. Adjust parameter oLn to the overload level that the motor can withstand during low speed operation.
oP1	[Overvoltage acceleration]	<ul style="list-style-type: none"> The input voltage is fluctuating abnormally. Power network is greater than 200 kVA. Power factor capacitor switching SCR switching on power network The drive is starting into a rotating load. Intermittent output phase fault 	<ul style="list-style-type: none"> Install a line reactor. Enable catch on the fly, parameter F301. Set parameter F302 to 2. Determine the cause of the missing output phase (such as a bad connection, an output disconnect, or an open winding in the motor) and rectify the trouble.
oP2	[Overvolt. deceleration]	<ul style="list-style-type: none"> The deceleration time is too short. Overhauling load The input voltage is fluctuating abnormally. Power network is greater than 200 kVA Power factor capacitor switching SCR switching on power network The drive is starting into a rotating load. Intermittent output phase fault 	<ul style="list-style-type: none"> Increase the deceleration time parameters (DEC or F501). Enable parameter F305. Install a line reactor. Check the input and output circuits for phase loss detection and rectify. Enable catch on the fly, parameter F301.

Code	Name	Possible causes	Remedies
OP3	[Overvoltage cont. speed]	<ul style="list-style-type: none"> The input voltage is fluctuating abnormally. Power network is greater than 200 kVA Power factor capacitor switching SCR switching on power network The drive is regenerating - the load causes the motor to run at a frequency higher than drive output frequency. Intermittent output phase fault 	<ul style="list-style-type: none"> Install a line reactor. Check the input and output circuits for phase loss detection and rectify.
OL	[Overtorque]	<ul style="list-style-type: none"> The calculated motor torque has reached the level set by parameter F616. 	<ul style="list-style-type: none"> Adjust the settings of parameters F615 and F616 as needed. Verify machine operation.
Prst F	[Prst Spd Error]	<ul style="list-style-type: none"> Prestart speed not reached. The load is too high. 	<ul style="list-style-type: none"> Reduce the load
SOot	[PM motor step-out] (permanent magnet motor pulls out of synchronism)	<ul style="list-style-type: none"> The motor is jammed. Output phase loss Impact load 	<ul style="list-style-type: none"> Check the load and correct the jammed condition. Check the condition of the motor and load wiring.
UL	[Underload]	<ul style="list-style-type: none"> The measured motor current has dropped below the level set by parameter F611. 	<ul style="list-style-type: none"> Check parameters F610-612 for the correct settings.
UPV	[Undervoltage]	<ul style="list-style-type: none"> The input voltage is too low. 	<ul style="list-style-type: none"> Check the input voltage and rectify the trouble. Select the correct setting for parameter F627. Enable catch on the fly, parameter F301. Set parameter F302 to 2.

Alarm Conditions

Alarms do not cause the drive to enter a fault condition.

Alarm Codes

Code	Description	Possible causes	Remedies
<i>A t n I</i>	[Auto tune]	<ul style="list-style-type: none"> Auto-tuning in process 	<ul style="list-style-type: none"> Normal if the message disappears after a few seconds.
<i>C L r</i>	[Reset active]	<ul style="list-style-type: none"> This message is displayed after the STOP key is pressed while an detected fault is displayed. 	<ul style="list-style-type: none"> Press the STOP key again to clear the detected fault.
<i>d b</i>	[DC braking]	<ul style="list-style-type: none"> DC braking in process 	<ul style="list-style-type: none"> The alarm code goes off in several seconds if no trouble occurs.
<i>d b o n</i>	[dbOn]	<ul style="list-style-type: none"> DC braking in process, when [Crankcase heating] (<i>F 3 5 5</i>) is activated. 	<ul style="list-style-type: none"> Normal behavior (if [Crankcase heating] (<i>F 3 5 5</i>) is activated, and the motor is stopped)
<i>E - 1 7</i>	[HMI error]	<ul style="list-style-type: none"> A graphic display option key has been held down for more than 20 seconds. A graphic display option key may not be operating properly. 	<ul style="list-style-type: none"> Release the graphic display option key. If this does not clear the error, replace the drive.
<i>E ,</i>	[Excess value] The number of digits that can be displayed has been exceeded	<ul style="list-style-type: none"> The number of digits entered for values such as frequencies is more than 4 (the upper digits have priority). 	<ul style="list-style-type: none"> Lower the frequency free-unit magnification [Customized freq val] (<i>F 7 0 2</i>).
<i>E o F F</i>	[Loc. Stop en.]	<ul style="list-style-type: none"> The operation panel is used to stop the operation in automatic control or remote control mode. 	<ul style="list-style-type: none"> Press the STOP key for an emergency stop. To cancel the emergency stop, press any other key.
<i>E r r I</i>	[Speed ref alarm]	<ul style="list-style-type: none"> The frequency setting signals at points 1 and 2 are set too close to each other. 	<ul style="list-style-type: none"> Set the frequency setting signals at points 1 and 2 apart from each other.
<i>h 9 9 9</i>	[Pin&1MWh] Integral input power	<ul style="list-style-type: none"> Integral input power is more than 999.99 kWh. 	<ul style="list-style-type: none"> Press and hold down the ENT key for 3 s or more when power is off or when the input terminal function CKWH is turned on or displayed.
<i>H 9 9 9</i>	[Pout&1MWh] Integral output power	<ul style="list-style-type: none"> Integral output power is more than 999.99 kWh. 	<ul style="list-style-type: none"> Press and hold down the ENT key for 3 s or more when power is off or when the input terminal function CKWH is turned on or displayed.
<i>H E A D E n d</i>	[Head] [End] Display of first/last data items	<ul style="list-style-type: none"> The first and last data item in the auh data group is displayed. 	<ul style="list-style-type: none"> Press MODE key to exit the data group.
<i>H I L o</i>	[High] [Low] Parameter adjustment error	<ul style="list-style-type: none"> During programming, a value was entered that exceeds the maximum or minimum value of the parameter. 	<ul style="list-style-type: none"> Enter a value within the bounds of the parameter
<i>i n i t</i>	[Initialization]	<ul style="list-style-type: none"> Parameters are being initialized to default values. 	<ul style="list-style-type: none"> Normal if the message disappears after several seconds.
<i>L 5 t P</i>	[Low speed stop] Auto-stop because of continuous operation at the lower-limit frequency	<ul style="list-style-type: none"> The automatic stop function selected with <i>F 2 5 6</i> was activated. 	<ul style="list-style-type: none"> To deactivate the automatic stop function, increase the frequency command above the lower-limit frequency <i>L L + F 3 9 1</i> or turn off the operation command.
<i>n o F F</i>	[Line undervolt flt]	<ul style="list-style-type: none"> The phase-to-phase input voltage is too low. 	<ul style="list-style-type: none"> Measure the main circuit supply voltage. If the voltage is at a normal level, the drive requires repair.
<i>o F F</i>	[Drive stop]	<ul style="list-style-type: none"> The ST-CC (run permissive) circuit is open. 	<ul style="list-style-type: none"> Close the ST-CC circuit.
<i>n 5 t</i>	[Lock State]	<ul style="list-style-type: none"> The Li is already active when the function is validated. The Li is already active when a configuration transfer is done with the function is validated. 	<ul style="list-style-type: none"> Deactivate the active Li configured.
<i>r e r y</i>	[Auto reset]	<ul style="list-style-type: none"> The drive is in the process of restart. A momentary stop occurred. 	<ul style="list-style-type: none"> The drive is operating normally if it restarts after several seconds.

<p>S t o p</p>	<p>[Stop supply] Momentary power loss slowdown stop prohibition function activated.</p>	<ul style="list-style-type: none"> • The slowdown stop prohibition function set with F 3 0 2 (momentary power loss ride-through operation) is activated. 	<ul style="list-style-type: none"> • To restart operation, reset the drive or input an operation signal again.
-----------------------	---	--	---

Pre-alarm Conditions

Pre-alarm Codes

Code	Pre-alarm	Description
<i>C</i>	[Current alarm]	<ul style="list-style-type: none"> The drive is at current limit. For more information, refer to parameter <i>F 6 0 1</i> (see page 73) and <i>F 1 8 5</i> (see page 79).
<i>P</i>	[DC bus alarm]	<ul style="list-style-type: none"> The drive is approaching an overvoltage detected fault due to a high supply line, regenerative motor braking, or a combination of these. For more information, refer to parameters <i>F 3 0 5</i> (see page 139) and <i>F 6 2 6</i> (see page 139).
<i>L</i>	[Motor overload al]	<ul style="list-style-type: none"> The motor overload timer has reached or exceeded 50% of its detected fault level.
<i>H</i>	[Drv overheat alm]	<ul style="list-style-type: none"> The drive is approaching an overheating fault detection.

The pre-alarm codes are displayed, flashing on the embedded HMI, in the following order from left to right: *C*, *P*, *L*, *H*.

If two or more troubles arise simultaneously, one of the following pre-alarm codes appears and flashes: *C P*, *P L*, *C P L*.

Clearing the detected fault

In the event of a non resettable detected fault:

- 1 Disconnect all power, including external control power that may be present.
- 2 Lock all power disconnects in the open position.
- 3 Wait 15 minutes to allow the DC bus capacitors to discharge (the drive LEDs are not indicators of the absence of DC bus voltage).
- 4 Measure the voltage of the DC bus between the PA/+ and PC/- terminals to ensure that the voltage is less than 42 Vdc.
- 5 If the DC bus capacitors do not discharge completely, contact your local Schneider Electric representative.
Do not repair or operate the drive.
 - Find and correct the detected fault.
 - Restore power to the drive to confirm the detected fault has been rectified.

When any overload function (OL 1 or OL 2) is active, the drive cannot be reset by inputting a reset signal from an external device or with the Stop key on the display terminal if the calculated cooling time has not expired.

Calculated cooling time:

- OL 1 : 30 seconds after the detected fault has occurred
- OL 2 : 120 seconds after the detected fault has occurred

NOTICE

RISK OF DAMAGE TO THE MOTOR

- Repeated reset of the thermal state after a thermal overload can result in thermal stress to the motor.
- When trips occur, promptly inspect the motor and driven equipment for problems (such as a locked shaft or mechanical overload) before restarting. Also check the power supplied to the motor for abnormal conditions (such as a phase loss or phase imbalance).

Failure to follow these instructions can result in equipment damage.

Annex



IV

What's in this Part?

This part contains the following chapters:

Chapter	Chapter Name	Page
15	Migration	191
17	Parameters Reset Tables	193
18	User Settings Tables	203

Migration

16

What's in this Chapter?

This chapter contains the following topics:

Topic	Page
Migration ATV21 - ATV212	192

Migration ATV21 - ATV212

General

The ATV212 is compatible with the ATV21

Migration Modbus ATV21 to ATV212: When controlling ATV21 using Modbus RJ45, parameter [Network protocol] (F B 2 9) should be set to 1.

With ATV212, parameter F B 2 9 should also be set to 1 and parameter [Com channel choice] (F B 0 7) set to [RJ45] (0). Factory setting is [Open style] (1).

Settings of other communication parameters described from page 148 remain the same as on ATV21.

Note: For LonWorks, parameter F B 2 9 needs to be set to 1 for ATV21 and needs to be set to 5 for ATV212.

A configuration transfer from ATV21 to ATV212 is possible.

For example:

You can upload a configuration from an ATV21 via PC Soft (and selected the inverter Type : ATV21) and download it into ATV212.

After a transfer from ATV21 to ATV212, the new parameters stay at their factory setting:

[Damper fdb type] (F 5 B 0), [Time open Damper] (F 5 B 1), [Time close Damper] (F 5 B 2), [Damper fit behavior] (F 5 B 3), [Forced fire control] (F 5 5 0), [Forced fire function] (F 5 5 9), [Com channel choice] (F B 0 7), [Mdb network baud] (F B 2 0), [Mdb network parity] (F B 2 1) and [LL for ov.cur. prev.] (F 3 9 0).

The download configuration is not allowed if the drive is running.

In case of an interruption of download configuration transfer to the drive and detected fault, the C F 1 2 is set. This detected fault code keeps also present even after power off of the drive.

To reset the download transfer detected fault code C F 1 2:

- Make a new successful transfer
- Make a factory setting on the drive (using E 4 P parameter)

At the end of download transfer, the drive cannot run if a logic input configured to a function is active. To use the function and run the motor, it's necessary to disable and enable the logic input.

Commissioning

Compatible loader tools with ATV212:

- SoMove V1.7.1.1 and higher,
- Multi-Loader V3.2 and higher,
- SoMoveMobile V2.2.7 and higher,
- PC soft is not compliant, since the software version V5.2 of the products ATV212.

▲ WARNING

LOSS OF CONTROL

Since the software version V5.2 of the products ATV212, PC soft is not compliant.

- Do not use PC soft with the products ATV212 V5.2 and at and above.

Failure to follow these instructions can result in death, serious injury, or equipment damage.

Parameters Reset Tables

17

Parameter Reset

Refer to Menu navigation diagram page [66](#) to know how to reach [\[Parameter reset\] \(EYP\)](#) parameter.

The Altivar 212 drive offers three parameter reset options:

- Factory reset: [\[Parameter reset\] \(EYP\)](#) = 3
- 50 Hz reset: [\[Parameter reset\] \(EYP\)](#) = 1
- 60 Hz reset: [\[Parameter reset\] \(EYP\)](#) = 2

This appendix describes parameter values after these reset operations.

The following tables identify:

- Parameters whose values after a reset do not vary by reset type, see page [194](#).
- Parameters whose values after a reset vary by reset type, see page [198](#).
- Parameters whose values after a reset are drive model dependant but do not vary by reset type, see page [199](#).
- Parameters whose values after a reset are drive model and reset type dependant, see page [200](#).
- Parameters whose values do not change if a reset is performed, see page [201](#).

Parameter values that do not vary by reset type

The table below lists the parameters whose values, after a reset, do not vary by the reset type.

To determine the value of a parameter after a reset, locate the parameter in the first column and read across the row to the default value column. The number that appears at the intersection of the parameter and the default value is the parameter's value after a reset of any type ([Parameter reset] (EYP) = 1, [Parameter reset] (EYP) = 2, or [Parameter reset] (EYP) = 3).

Parameters whose values after a reset do not vary by reset type

Parameter	Description	Unit	Default Value
Ar 1	[Auto ramp]	–	1
Ar 4	[Auto set function]	–	0
F 05 L	[AO funct. selection]	–	0
F 07	[AO scaling]	–	–
E Y P	[Parameter reset]	–	0
F r	[Local mot. direction]	–	0
F C	[Local speed ref.]	Hz	0.0
L L	[Low limit frequency]	Hz	0.0
P E	[Mot cont. mode sel.]	–	1
o L 0	[Motor overload prot]	–	0
S r 1	[Preset speed 1]	Hz	15
S r 2	[Preset speed 2]	Hz	20
S r 3	[Preset speed 3]	Hz	25
S r 4	[Preset speed 4]	Hz	30
S r 5	[Preset speed 5]	Hz	35
S r 6	[Preset speed 6]	Hz	40
S r 7	[Preset speed 7]	Hz	45
F 100	[Freq. 1 reached]	Hz	0.0
F 101	[Freq. 2 reached]	Hz	0.0
F 102	[Freq.2 bandw.]	Hz	2.5
F 108	[Logic Funct 1 active]	–	0
F 109	[VIA selection]	–	0
F 110	[Logic Funct 2 active]	–	1
F 111	[LI F selection]	–	2
F 112	[LI R selection]	–	6
F 113	[LI RES selection]	–	10
F 118	[VIA LI selection]	–	7
F 130	[RY Relay Function 1]	–	4
F 132	[FL Relay Function]	–	11
F 137	[RY Relay Function 2]	–	255
F 139	[RY logic select.]	–	0
F 167	[Freq band det range]	Hz	2.5
F 200	[Auto/man speed ref]f	–	0
F 201	[VIB ref. point 1]	%	0
F 202	[VIA freq. point 1]	Hz	0.0
F 203	[VIA freq. point 2]	%	100
F 207	[Remote spd ref 2]	–	2
F 210	[VIB ref. point 1]	%	0

Parameter	Description	Unit	Default Value
F 2 1 1	[VIB freq. point 1]	Hz	0.0
F 2 1 2	[VIB ref. point 2]	%	100
F 2 4 0	[Mot start freq.]	Hz	0.5
F 2 4 1	[Freq. pedestal]	Hz	0.0
F 2 4 2	[Freq. pedestal hyst.]	Hz	0.0
F 2 5 0	[DC brake start freq.]	Hz	0.0
F 2 5 1	[DC braking current]	A	50
F 2 5 2	[DC braking time]	s	1.0
F 2 5 6	[Time limit low spd]	s	0.0
F 2 6 4	[+speed LI resp time]	s	0.1
F 2 6 5	[+speed freq. step]	Hz	0.1
F 2 6 6	[- speed LI resp time]	s	0.1
F 2 6 7	[- speed freq. step]	Hz	0.1
F 2 6 8	[Init +/- Speed]	Hz	0.0
F 2 6 9	[Init +/- Speed memo]	–	1
F 2 7 0	[Jump frequency 1]	Hz	0.0
F 2 7 1	[Jump bandwidth 1]	Hz	0.0
F 2 7 2	[Jump frequency 2]	Hz	0.0
F 2 7 3	[Jump bandwidth 2]	Hz	0.0
F 2 7 4	[Jump frequency 3]	Hz	0.0
F 2 7 5	[Jump bandwidth 3]	Hz	0.0
F 2 9 4	[Forced speed freq.]	Hz	50
F 2 9 5	[Switch rem/Local]	–	1
F 3 0 1	[Catch on fly]	–	3
F 3 0 2	[Supply loss behav.]	–	0
F 3 0 5	[Overvoltage fault]	–	2
F 3 0 7	[Mot volt limitation]	–	3
F 3 1 1	[Motor direction]	–	1
F 3 1 2	[Noise reduction]	–	0
F 3 1 6	[Switch. freq. mode]	–	1
F 3 2 0	[Load gain]	%	0
F 3 2 3	[Load gain offset]	%	10
F 3 5 9	[PID ctrl wait time]	s	0
F 3 6 0	[PID control enable]	–	0
F 3 6 2	[PID Prop Gain]	–	0.30
F 3 6 3	[PID Integral Gain]	–	0.20
F 3 6 6	[PID Derivative Gain]	–	0.00
F 4 0 0	[Auto-tuning drive]	–	0
F 4 0 1	[Slip Compensation]	%	50
F 4 1 8	[Frequency loop gain]	–	40
F 4 1 9	[Freq. loop stability]	–	20
F 4 7 0	[VIA bias]	–	128
F 4 7 1	[VIA gain]	–	148
F 4 7 2	[VIB bias]	–	128
F 4 7 3	[VIB gain]	–	148
F 4 8 2	[In noise Inhibit filter]	μs	442

Parameter	Description	Unit	Default Value
F 483	[In noise inhibit gain]	–	100
F 484	[Pwr supply adj. gain]	–	0.0
F 485	[Stall control coef. 1]	–	100
F 492	[Stall control coef. 2]	–	100
F 495	[Motor voltage coef.]	%	104
F 496	[PWM adj. coef.]	kHz	14.0
F 502	[Acc/dec 1 pattern]	–	0
F 503	[Acc/dec 2 pattern]	–	0
F 504	[Ramp switching]	–	1
F 505	[Commut. ramp freq.]	Hz	0.0
F 506	[Acc/Dec S-pat start]	%	10
F 507	[Acc/Dec S-pat end]	%	10
F 502	[Drive fault memory]	–	0
F 503	[Ext. fault stop Mode]	–	0
F 504	[DC brk time ext fit]	s	1.0
F 505	[Output phase loss]	–	3
F 507	[Mot overload time]	s	300
F 508	[Input phase loss]	–	1
F 509	[Underload band]	%	10
F 510	[Underload det.]	–	0
F 511	[Underload level]	% / A	0
F 512	[Underload det. time]	s	0
F 513	[Short circuit det.]	–	0
F 515	[Overtorque det.]	–	0
F 516	[Overtorque level]	%	130
F 518	[OvTorque det time]	s	0.5
F 519	[Overtorque band]	%	10
F 521	[Run time alarm]	h	610.0 (6100 h)
F 527	[Undervolt detect.]	–	0
F 532	[Mot overload memo]	–	0
F 533	[Loss of VIA]	%	0
F 534	[Amb. temp. alarm]	–	3
F 545	[Mot PTC selection]	–	0
F 546	[PTC resistor value]	Ω	3000
F 550	[Forced fire control]	–	0
F 591	[AO slope]	–	1
F 592	[Analog output bias]	%	0
F 700	[Parameter lock]	–	0
F 701	[Unit value selection]	–	1
F 702	[Customized freq val]	–	0
F 703	[Frequency convert.]	–	0
F 706	[Customize unit bias]	Hz	0.0
F 707	[Loc. speed ref. step]	Hz	0.0
F 708	[Display ref. resol.]	–	0
F 710	[Displayed param.]	–	0
F 721	[Loc. mot stop mode]	–	0

Parameter	Description	Unit	Default Value
<i>F 730</i>	[Up/down key ref]	–	0
<i>F 732</i>	[Loc/rem key]	–	0
<i>F 733</i>	[Run/stop key]	–	0
<i>F 734</i>	[Priority stop]	–	0
<i>F 735</i>	[HMI reset button]	–	1
<i>F 738</i>	[Quick menu AUF]	–	0
<i>F 748</i>	[Power cons. memo]	–	1
<i>F 800</i>	[Mdb RJ45 baud]	–	1
<i>F 801</i>	[Mdb RJ45 parity]	–	1
<i>F 802</i>	[Modbus address]	–	1
<i>F 803</i>	[Com. time out]	s	3
<i>F 829</i>	[Network protocol]	–	1
<i>F 851</i>	[Com. fault setting]	–	4
<i>F 856</i>	[Mot. poles (comm.)]	–	2
<i>F 870</i>	[Block write data 1]	–	0
<i>F 871</i>	[Block write data 2]	–	0
<i>F 875</i>	[Block read data 1]	–	0
<i>F 876</i>	[Block read data 2]	–	0
<i>F 877</i>	[Block read data 3]	–	0
<i>F 878</i>	[Block read data 4]	–	0
<i>F 879</i>	[Block read data 5]	–	0
<i>F 880</i>	[Free ID parameter]	–	0
<i>F 890</i>	[Network address]	–	(1)
<i>F 891</i>	[Network baud rate]	–	(1)
<i>F 892</i>	[Network time out]	–	(1)
<i>F 893</i>	[Instance number H]	–	(1)
<i>F 894</i>	[Instance number L]	–	(1)
<i>F 895</i>	[Max master]	–	(1)
<i>F 896</i>	[Max info frames]	–	(1)

(1) See table page [199](#).

Parameter values that vary according to reset type

The table below lists the parameters whose values, after a reset, depend on the reset type ([Parameter reset] (EYP) = 1, [Parameter reset] (EYP) = 2, or [Parameter reset] (EYP) = 3).

To determine the value of a parameter after a reset, locate the parameter in the first column and read across the row to the column that corresponds to the reset type. The number that appears at the intersection of the parameter and the reset type is the parameter's value after a reset of the corresponding type.

Parameters whose values after a reset vary by reset type

Parameter	Description	Unit	Factory Reset EYP = 3	50 Hz Reset EYP = 1	60 Hz Reset EYP = 2
<i>C P o d</i>	[Command mode sel]	–	0	0	0
<i>F P o d</i>	[Frequency mode sel]	–	1	1	1
<i>F H</i>	[Max frequency]	Hz	50	50	60
<i>u L</i>	[Upper limit freq]	Hz	50	50	60
<i>u L</i>	[Motor rated freq.]	Hz	50	50	60
<i>F 1 7 0</i>	[Mot 2 rated Freq.]	Hz	50	50	60
<i>F 2 0 4</i>	[VIA freq. point 2]	Hz	50	50	60
<i>F 2 1 3</i>	[VIB freq. point 2]	Hz	50	50	60
<i>F 3 0 3</i>	[Number auto reset]	–	0	0	0
<i>F 4 8 0</i>	[No load cur. coef]	%	100	0	100
<i>F 4 8 1</i>	[In noise comp. filter]	micro-seconds	0	100	0

Parameter values that vary According to drive rating, but not reset type

The table below lists the parameters whose values, after a reset, depend on the drive model.

To determine the value of a parameter after a reset, locate the drive model number in first column and read across the row to the column that corresponds to the parameter code. The number that appears at the intersection of the model number and the parameter code is the parameter's value after a reset. These values are the same for every reset types ([Parameter reset] (EYP) = 1, [Parameter reset] (EYP) = 2, or [Parameter reset] (EYP) = 3).

Parameters whose values after a reset are drive model dependant but do not vary by reset type

Reference	Parameter										
	ACC	dEC	vLv	ub	F171	F172	F300	F402	F494	F626	F749
	s	s	V	%	V	%	kHz	%	-	%	-
ATV212H075M3X	10	10	200	6	200	6	12	5.8	80	140	0
ATV212HU15M3X	10	10	200	6	200	6	12	4.3	70	140	0
ATV212HU22M3X	10	10	200	5	200	5	12	4.1	70	140	0
ATV212HU30M3X	10	10	200	5	200	5	12	3.7	70	140	0
ATV212HU40M3X	10	10	200	5	200	5	12	3.4	70	140	1
ATV212HU55M3X	10	10	200	4	200	4	12	3.0	70	140	1
ATV212HU75M3X	10	10	200	3	200	3	12	2.5	70	140	1
ATV212HD11M3X	10	10	200	2	200	2	12	2.3	60	140	1
ATV212HD15M3X	10	10	200	2	200	2	12	2.0	50	140	1
ATV212HD18M3X	30	30	200	2	200	2	8	2.0	50	140	1
ATV212HD22M3X	30	30	200	2	200	2	8	1.8	50	140	1
ATV212HD30M3X	30	30	200	2	200	2	8	1.8	50	140	1
ATV212H075N4	10	10	400	6	400	6	12	5.8	80	140	0
ATV212HU15N4	10	10	400	6	400	6	12	4.3	70	140	0
ATV212HU22N4	10	10	400	5	400	5	12	4.1	70	140	0
ATV212HU30N4	10	10	400	5	400	5	12	3.7	70	140	0
ATV212HU40N4	10	10	400	5	400	5	12	3.4	70	140	1
ATV212HU55N4	10	10	400	4	400	4	12	2.6	70	140	1
ATV212HU75N4	10	10	400	3	400	3	12	2.3	70	140	1
ATV212HD11N4	10	10	400	2	400	2	12	2.2	60	140	1
ATV212HD15N4	10	10	400	2	400	2	12	1.9	50	140	1
ATV212HD18N4	30	30	400	2	400	2	8	1.9	50	140	1
ATV212HD22N4S	30	30	400	2	400	2	6	1.8	50	140	1
ATV212HD22N4	30	30	400	2	400	2	8	1.8	50	140	1
ATV212HD30N4	30	30	400	2	400	2	8	1.8	50	140	1
ATV212HD37N4	30	30	400	2	400	2	8	1.8	50	140	2
ATV212HD45N4	30	30	400	2	400	2	8	1.7	50	140	2
ATV212HD55N4	30	30	400	2	400	2	8	1.6	40	140	2
ATV212HD75N4	30	30	400	2	400	2	8	1.5	40	140	2

Parameter values that vary According to drive rating and reset type

The table below lists the parameters whose values, after a reset, depend on the drive model and the reset type ([Parameter reset] (L Y P) = 1, [Parameter reset] (L Y P) = 2, or [Parameter reset] (L Y P) = 3). To determine the value of a parameter after a reset:

1. Locate the drive model number in the first column.
2. Read across the row to the group of columns that corresponds to the reset type ([Parameter reset] (L Y P) = 1, [Parameter reset] (L Y P) = 2, or [Parameter reset] (L Y P) = 3).
3. Locate the parameter code in the columns corresponding to the reset type.

The number that appears at the intersection of the drive model number and the parameter code is the parameter's value after a reset of the specified type.

Parameters whose values after a reset are drive model and reset type dependant

Reference	Factory reset L Y P = 3				50 Hz reset L Y P = 1							60 Hz reset L Y P = 2						
	tHr	F173	F185	F601	tHr	F173	F185	F415	F416	F417	F601	tHr	F173	F185	F415	F416	F417	F601
	%	%	%	%	%	%	%	A	%	rpm	%	%	%	%	A	%	rpm	%
ATV212H075M3X	100	100	110	110	100	100	110	3.5	64	1400	110	100	100	110	3.0	60	1700	110
ATV212HU15M3X	100	100	110	110	100	100	110	6.1	61	1420	110	100	100	110	5.8	59	1715	110
ATV212HU22M3X	100	100	110	110	100	100	110	8.8	59	1430	110	100	100	110	8.0	61	1715	110
ATV212HU30M3X	100	100	110	110	100	100	110	12.5	63	1420	110	100	100	110	12.4	48	1760	110
ATV212HU40M3X	100	100	110	110	100	100	110	15.8	61	1425	110	100	100	110	15.2	51	1769	110
ATV212HU55M3X	100	100	110	110	100	100	110	20.6	57	1430	110	100	100	110	22.0	53	1780	110
ATV212HU75M3X	100	100	110	110	100	100	110	26.3	54	1450	110	100	100	110	28.0	42	1780	110
ATV212HD11M3X	100	100	110	110	100	100	110	36.9	53	1450	110	100	100	110	36.0	39	1766	110
ATV212HD15M3X	100	100	110	110	100	100	110	49.5	53	1455	110	100	100	110	48.0	36	1771	110
ATV212HD18M3X	100	100	110	110	100	100	110	61.0	53	1455	110	100	100	110	61.0	39	1771	110
ATV212HD22M3X	100	100	110	110	100	100	110	68.0	53	1460	110	100	100	110	68.0	36	1771	110
ATV212HD30M3X	100	100	110	110	100	100	110	93.0	50	1460	110	100	100	110	93.0	33	1771	110
ATV212H075N4	100	100	110	110	100	100	110	2.0	64	1400	110	100	100	110	1.5	60	1720	110
ATV212HU15N4	100	100	110	110	100	100	110	3.5	61	1420	110	100	100	110	2.9	59	1700	110
ATV212HU22N4	100	100	110	110	100	100	110	5.1	59	1430	110	100	100	110	4.0	61	1715	110
ATV212HU30N4	100	100	110	110	100	100	110	7.2	63	1420	110	100	100	110	6.2	48	1715	110
ATV212HU40N4	100	100	110	110	100	100	110	9.1	61	1425	110	100	100	110	7.6	51	1760	110
ATV212HU55N4	100	100	110	110	100	100	110	11.9	57	1430	110	100	100	110	11.0	53	1769	110
ATV212HU75N4	100	100	110	110	100	100	110	15.2	54	1450	110	100	100	110	14.0	42	1780	110
ATV212HD11N4	100	100	110	110	100	100	110	21.3	53	1450	110	100	100	110	21.0	39	1780	110
ATV212HD15N4	100	100	110	110	100	100	110	28.6	53	1455	110	100	100	110	27.0	36	1766	110
ATV212HD18N4	100	100	110	110	100	100	110	35.1	53	1455	110	100	100	110	35.1	39	1771	110
ATV212HD22N4S	100	100	110	110	100	100	110	41.7	53	1460	110	100	100	110	41.7	36	1780	110
ATV212HD22N4	100	100	110	110	100	100	110	41.7	53	1460	110	100	100	110	41.7	36	1771	110
ATV212HD30N4	100	100	110	110	100	100	110	55.0	50	1460	110	100	100	110	55.0	33	1771	110
ATV212HD37N4	100	100	110	110	100	100	110	67	51	1475	110	100	100	110	67	31	1771	110
ATV212HD45N4	100	100	110	110	100	100	110	81	51	1475	110	100	100	110	71	34	1771	110
ATV212HD55N4	100	100	110	110	100	100	110	99	53	1480	110	100	100	110	86	31	1771	110
ATV212HD75N4	100	100	110	110	100	100	110	135	53	1480	110	100	100	110	114	31	1771	110

Parameter values that do not change if reset

The parameters listed in the table below cannot be reset. The table lists the default settings of these parameters.

Parameters whose values do not change if a reset is performed

Parameter	Description	Default Value
<i>F 0</i>	[AO scaling]	–
<i>F 0 5 L</i>	[AO funct. selection]	0
<i>F 1 0 9</i>	[VIA selection]	0
<i>F 4 7 0</i>	[VIA bias]	128
<i>F 4 7 1</i>	[VIA gain]	148
<i>F 4 7 2</i>	[VIB bias]	128
<i>F 4 7 3</i>	[VIB gain]	148
<i>F 8 8 0</i>	[Free ID parameter]	0

User Settings Tables

Use the Configuration Setting Table to look up parameter default settings, to record customized parameter settings, and to look up sections of the manual, by page number, that contain detailed parameter descriptions.

Configuration Setting Table

Code	Page	Name	Unit	Adjustment Range / Function	Factory Setting	User Setting
<i>FL</i>	87	[Local speed ref.]	Hz	– [Low limit frequency] (<i>LL</i>) to [Upper limit freq] (<i>UL</i>)	0.0	
<i>RUL</i>	95	[Auto ramp]	-	<i>0</i> [Disabled]	1	
				<i>1</i> [Enable]		
				<i>2</i> [ACC only]		
<i>RUC</i>	67	[Auto set function]	-	<i>0</i> [Factory set]	0	
				<i>1</i> [Run permissive]		
				<i>2</i> [3-wire]		
				<i>3</i> [+/- Speed]		
<i>CLMd</i>	87	[Command mode sel]	-	<i>4</i> [4-20mA speed ref]	0	
				<i>0</i> [Logic inputs]		
				<i>1</i> [HMI]		
				<i>2</i> [Communication]		
<i>FLMd</i>	87	[Frequency mode sel]	-	<i>1</i> [Ref source VIA]	1	
				<i>2</i> [Ref source VIB]		
				<i>3</i> [HMI reference]		
				<i>4</i> [Serial com ref.]		
				<i>5</i> [+/- Speed]		
<i>FNSL</i>	118	[AO funct. selection]	-	<i>0</i> [Motor frequency]	0	
				<i>1</i> [Motor current]		
				<i>2</i> [Speed ref]		
				<i>3</i> [DC bus U]		
				<i>4</i> [Motor U]		
				<i>5</i> [Input power]		
				<i>6</i> [Output power]		
				<i>7</i> [motor torque]		
				<i>8</i> [Torque I]		
				<i>9</i> [Motor thermal]		
				<i>10</i> [Drive thermal]		
				<i>11</i> [Do not use]		
				<i>12</i> [Internal reference]		
				<i>13</i> [VIA]		
				<i>14</i> [VIB]		
				<i>15</i> [Fixed 100%]		
				<i>16</i> [Fixed 50%]		
				<i>17</i> [Fixed 100%]		
				<i>18</i> [Com data]		
<i>19</i> [Do not use]						
<i>FN</i>	118	[AO scaling]	-	–	–	

Code	Page	Name	Unit	Adjustment Range / Function		Factory Setting	User Setting
EtYP	<u>66</u>	[Parameter reset]	-	0	[No action]	0	-
				1	[50 Hz reset]		
				2	[60 Hz reset]		
				3	[Factory set]		
				4	[Trip cleared]		
				5	[Cumul time clear]		
				6	[EtYP fault reset]		
				7	[Save parameters]		
				8	[Recall parameters]		
9	[Elapse time reset]						
Fr	<u>87</u>	[Local mot. direction]	-	0	[Run FW]	0	
				1	[Run rev.]		
				2	[Run FW+rev]		
				3	[Run rev+FW]		
ACC	<u>93</u> <u>163</u>	[Acceleration time 1]	s	-	0.0 – 3200	Model dependent	
DEC	<u>93</u> <u>162</u>	[Deceleration time 1]	s	-	0.0 – 3200	Model dependent	
FH	<u>92</u> <u>162</u>	[Max frequency]	Hz	-	30.0 – 400.0	50.0	
UL	<u>92</u> <u>161</u>	[Upper limit freq]	Hz	-	0.5 – [Max frequency] (FH)	50.0	
LL	<u>92</u> <u>161</u>	[Low limit frequency]	Hz	-	0.0 – [Upper limit freq] (UL)	0.0	
UL	<u>74</u> <u>161</u>	[Motor rated freq.]	Hz	-	25.0 – 200.00	50.0	
ULV	<u>74</u> <u>160</u>	[Motor Rated Voltage]	V	230 V models	50 – 330	230	
				460 V models	50 – 660	400	
PE	<u>71</u> <u>82</u>	[Mot cont. mode sel.]	-	0	[Constant V/Hz]	1	
				1	[Variable Torque]		
				2	[Cst V/Hz+Boost]		
				3	[SVC]		
				4	[Economy]		
				5	[Do not use]		
6	[PM Control]						
ub	<u>73</u>	[Motor Voltage Boost]	%	-	0.0 – 30.0	Model dependent	
EHr	<u>74</u>	[Motor thermal prot.]	%/A	-	10 – 100% of drive's output current rating	100%	
OLP	<u>146</u>	[Motor overload prot]	-	0	[Std mot. protect.]	0	
				1	[Std & stall mot. prot]		
				2	[Self cool]		
				3	[Sif cool stall ov.load]		
				4	[Forced cool prot]		
				5	[Forc cool stall prot]		
				6	[Forced cool]		
7	[F cool & stall ov load]						
Sr1	<u>123</u>	[Preset speed 1]	Hz	1	[Low limit frequency] (LL) to [Upper limit freq] (UL)	15	
Sr2	<u>123</u>	[Preset speed 2]	Hz	1	[Low limit frequency] (LL) to [Upper limit freq] (UL)	20	
Sr3	<u>123</u>	[Preset speed 3]	Hz	1	[Low limit frequency] (LL) to [Upper limit freq] (UL)	25	
Sr4	<u>123</u>	[Preset speed 4]	Hz	1	[Low limit frequency] (LL) to [Upper limit freq] (UL)	30	
Sr5	<u>123</u>	[Preset speed 5]	Hz	1	[Low limit frequency] (LL) to [Upper limit freq] (UL)	35	
Sr6	<u>123</u>	[Preset speed 6]	Hz	1	[Low limit frequency] (LL) to [Upper limit freq] (UL)	40	
Sr7	<u>123</u>	[Preset speed 7]	Hz	1	[Low limit frequency] (LL) to [Upper limit freq] (UL)	45	
F100	<u>125</u>	[Freq. 1 reached]	Hz	-	0.0 to [Max frequency] (FH)	0.0	

Code	Page	Name	Unit	Adjustment Range / Function		Factory Setting	User Setting
F 101	125	[Freq. 2 reached]	Hz	-	0.0 to [Max frequency] (F H)	0.0	
F 102	125	[Freq.2 bandw.]	Hz	-	0.0 to [Max frequency] (F H)	2.5	
F 108	122	[Logic Funct 1 active]	-	0 – 73	See table on page 101	0	
F 109	100	[VIA selection]	-	0	AI	0	
				1	LI sink		
				2	LI source		
F 110	122	[Logic Funct 2 active]	-	0 – 73	See table page 194	1	
F 111	100	[LI F selection]	-	0 – 72	See table page 194	2	
F 112	100	[LI R selection]	-	0 – 72	See table page 194	6	
F 113	100	[LI RES selection]	-	0 – 72	See table page 194	10	
F 118	100	[VIA LI selection]	-	0 – 73	See table page 194	7	
F 130	119	[RY Relay Function 1]	-	0 – 61, 254, 255	See table page 194	4	
F 132	120	[FL Relay Function]	-	0 – 61, 254, 255	See table page 194	11	
F 137	124	[RY Relay Function 2]	-	0 – 61, 254, 255	See table page 194	255	
F 139	124	[RY logic select.]	-	0	Function 1and 2	0	
				1	Function 1 or 2		
F 146	119	[RY delay]	s	-	0.0 – 60.0 s	0.0	
F 147	120	[FL Relay delay]	s	-	0.0 – 60.0 s	0.0	
F 160	116	[VIA rel thresh. logic]	%	-	0 – 100	0	
F 161	116	[VIA threshold hyst.]	%	-	0 – 20	3	
F 162	116	[VIB rel thresh. logic]	%	-	0 – 100	0	
F 163	116	[VIB threshold hyst.]	%	-	0 – 20	3	
F 167	126	[Freq band det range]	Hz	-	0.0 to [Max frequency] (F H)	2.5	
F 170	79	[Mot 2 rated Freq.]	Hz	-	25.0 to 200.0	50.0	
F 171	79	[Motor 2 rated Volt]	V	230V model	50 to 330	230	
				460V model	50 to 660	400	
F 172	79	[Motor 2 Volt Boost]	%	-	0 – 30	Model dependant	
F 173	79	[Motor 2 Overload]	%/A	-	10 – 100% of drive rating	100	
F 185	79	[Mot. 2 current limit]	%/A	-	10 – 110%	110	
F 200	118	[Auto/man speed ref]	-	0	[Enable]	0	
				1	[Disable]		
F 201	116	[VIA ref point 1]	%	-	0 – 100	0	
F 202	116	[VIA freq. point 1]	Hz	-	0.0 – 200.0	0.0	
F 203	116	[VIA freq. point 2]	%	-	0 – 100	100	
F 204	116	[VIA freq. point 2]	Hz	-	0.0 – 200.0	50.0	
F 207	88	[Remote spd ref 2]	-	1	[VIA]	2	
				2	[VIB]		
				3	[HMI]		
				4	[Communication]		
				5	[+/- Speed]		
F 210	116	[VIB ref. point 1]	%	-	0 – 100	0	
F 211	116	[VIB freq. point 1]	Hz	-	0.0 – 200.0	0.0	
F 212	116	[VIB ref. point 2]	%	-	0 – 100	100	
F 213	116	[VIB freq. point 2]	Hz	-	0.0 – 200.0	50.0	
F 240	92	[Mot start freq.]	Hz	-	0.5 – 10.0	0.5	
F 241	154	[Freq. pedestal]	Hz	-	0.0 – [Max frequency] (F H)	0.0	

Code	Page	Name	Unit	Adjustment Range / Function		Factory Setting	User Setting
F 242	154	[Freq. pedestal hyst.]	Hz	-	0.0 – [Max frequency] (F H)	0.0	
F 250	98	[DC brake start freq.]	Hz	-	0.0 – [Max frequency] (F H)	0.0	
F 251	98	[DC braking current]	%/A	-	0 – 100%	50	
F 252	98	[DC braking time]	s	-	0.0 – 20.0	1.0	
F 256	88	[Time limit low spd]	s	0	[Disable]	0.0	
				1	[Enable]		
F 264	124	[+speed LI resp time]	s	-	0.0 – 10.0	0.1	
F 265	124	[+speed freq. step]	Hz	-	0.0 – [Max frequency] (F H)	0.1	
F 266	124	[- speed LI resp time]	s	-	0.0 – 10.0	0.1	
F 267	124	[- speed freq. step]	Hz	-	0.0 – [Max frequency] (F H)	0.1	
F 268	124	[Init +/- Speed]	Hz	-	0.0 – [Max frequency] (F H)	0.0	
F 269	124	[Init +/- Speed memo]	-	0	[Disable]	1	
				1	[Enable]		
F 270	97	[Jump frequency 1]	Hz	-	0.0 – [Max frequency] (F H)	0.0	
F 271	97	[Jump bandwidth 1]	Hz	-	0.0 – 30.0	0.0	
F 272	97	[Jump frequency 2]	Hz	-	0.0 – [Max frequency] (F H)	0.0	
F 273	97	[Jump bandwidth 2]	Hz	-	0.0 – 30.0	0.0	
F 274	97	[Jump frequency 3]	Hz	-	0.0 – [Max frequency] (F H)	0.0	
F 275	97	[Jump bandwidth 3]	Hz	-	0.0 – 30.0	0.0	
F 294	89	[Forced speed freq.]	Hz	-	[Low limit frequency] (L L) – [Upper limit freq] (U L)	50.0	
F 295	88	[Switch rem/Local]	-	0	[No bumpless]	1	
				1	[Bumpless]		
F 300	95	[Switch. freq. level]	kHz	-	6.0 – 16.0	Model dependent	
F 301	137	[Catch on fly]	-	0	[Disable]	3	
				1	[Brief power loss]		
				2	[Run restored]		
				3	[Power loss, run]		
F 302	138	[Supply loss behav.]	-	0	[Disabled]	0	
				1	[Do not use]		
				2	[Freewheel]		
				0	[Disabled]		
F 303	135 169	[Number auto reset]	-	0	[Disabled]	0	
				1 - 10	[Number of fault reset attempts]		
F 305	139	[Overvoltage fault]	-	0	[Enable]	2	
				1	[Disabled]		
				2	[Quick deceleration]		
				3	[Dyn. deceleration]		
F 307	78	[Mot volt limitation]	-	0	[Motor volt limit]	3	
				1	[Line & mot correct.]		
				2	[No action]		
F 311	96 160	[Motor direction]	-	0	[U Line correction]	1	
				1	[Fw & Rev.]		
				2	[Fw only]		
F 312	96	[Noise reduction]	-	0	[Rev. only]	0	
				1	[Disable]		
				1	[Enable]		
F 316	96	[Switch. freq. mode]	-	0	[Fixed]	1	
				1	[Auto]		
				2	[460 V fixed]		
F 320	156	[Load gain]	%	-	0 – 100	0	
				3	[460 V Auto]		
F 323	156	[Load gain offset]	%	-	0 – 100	10	
F 324	160	[Driving Scroll]	-	0	[No]	0	
				1	[Yes]		

Code	Page	Name	Unit	Adjustment Range / Function		Factory Setting	User Setting
F 325	170	[Pre-start Scroll]	-	0	[No]	0	
				1	[Yes]		
F 326	170	[Pre-Start time]	s	-	0 – 6000	10	
F 327	171	[Pre-Start speed]	Hz	-	0.0 – [Upper limit freq] (UL)	50	
F 328	171	[LL speed time]	s	-	0 – 10	2	
F 329	171	[Pre-start delay]	s	-	0 – 120	3	
F 330	172	[Std Oiling Cycle]	-	0	[No]	0	
				1	[Yes]		
F 331	172 173	[Std Oiling Speed]	Hz	-	0.0 – [Upper limit freq] (UL)	70	
F 332	172	[Std Oiling Time]	s	-	0 – 6000	30	
F 333	172	[Std Oil. Cycle Frq.]	Hours	-	0 – 24	24	
F 334	173	[Low Speed Oiling]	-	0	[No]	0	
				1	[Yes]		
F 335	173	[LL Speed for Oiling]	Hz	-	0.0 – [Upper limit freq] (UL)	50	
F 336	173	[LLS Time for Oiling]	mn	-	0.0 – 360	60	
F 337	173	[Oiling Time at LLS]	s	-	0.0 – 6000	30	
F 338	174	[Scroll Protection]	-	0	[No]	0	
				1	[Yes]		
F 339	174	[Cavitation Frq.]	Hz	-	[Low limit frequency] (LL) – [Upper limit freq] (UL)	30	
F 349	175	[Discharge gas]	-	0	[No]	0	
				1	[VIA]		
				2	[VIB]		
F 350	175	[High Thd]	%	-	0 – 100	65	
F 351	175	[Cooling Frq.]	Hz	-	[Low limit frequency] (LL) – [Upper limit freq] (UL)	50	
F 352	175	[Cooling Time]	mn	-	0 – 30	3	
F 353	175	[High high Thd]	%	-	0 – 100	70	
F 354	175	[Re-Start Delay]	mn	-	0 – 30	5	
F 355	176	[Crankcase heating]	-	0	[No]	0	
				1	[Yes]		
F 359	121	[PID ctrl wait time]	s	-	0 – 2400	0	
F 360	120	[PID control enable]	-	0	[No PID]	0	
				1	[PID by VIA]		
				2	[PID by VIB]		
F 362	120	[PID Prop Gain]	-	-	0.01 – 100.0	0.30	
F 363	120	[PID Integral Gain]	-	-	0.01 – 100.0	0.20	
F 366	121	[PID Derivative Gain]	-	-	0.00 – 2.55	0.00	
F 380	121	[PID reverse error]	-	0	[No]	0	
				1	[Yes]		
F 391	122	[Stop on LL hyst]	Hz	-	0.0 – [Max frequency] (FH)	0.2	
F 392	122	[PID wake up (thres)]	Hz	-	0.0 – [Max frequency] (FH)	0.0	
F 393	122	[PID wake up, feedb]	Hz	-	0.0 – [Max frequency] (FH)	0.0	
F 400	76 165	[Auto-tuning drive]	-	0	[Disabled]	0	
				1	[Initialize constant]		
				2	[Tun Static]		
				3	[Tun Dyn.]		
				4	[Tun Prst 1]		
5	[Tun Prst 2]						
F 401	79 162	[Slip Compensation]	%	-	0 – 150	50	
F 402	79 162	[Auto Torque Boost]	%	-	0.0 – 30.0	Model dependent	

Code	Page	Name	Unit	Adjustment Range / Function		Factory Setting	User Setting
F 4 0 5	82	[Motor rated freq.]	kW	-	0.01 – 75	Model dependent	
F 4 1 5	74 161	[Motor rated current]	A	-	0.1 – 200.0	Model dependent	
F 4 1 6	74	[Mot no-load current]	%	-	10.0 – 100.0	Model dependent	
F 4 1 7	74 161	[Motor rated speed]	rpm	-	100 – 15000	Model dependent	
F 4 1 8	80 166	[Frequency loop gain]	-	-	1 – 150	40	
F 4 1 9	80 166	[Freq. loop stability]	-	-	1 – 100	20	
F 4 2 0	85 166	[Torque Boost Coef]	%	-	0 – 200	Model dependent	
F 4 5 8	165	[Current loop gain]	Hz	-	0 – 100	0	
F 4 7 0	117	[VIA bias]	-	-	0 – 255	128	
F 4 7 1	117	[VIA gain]	-	-	0 – 255	148	
F 4 7 2	117	[VIB bias]	-	-	0 – 255	128	
F 4 7 3	117	[VIB gain]	-	-	0 – 255	148	
F 4 8 0	77	[No load cur. coef]	-	-	100 – 130	100	
F 4 8 1	144	[In noise comp. filter]	μs	-	0 – 9999	0	
F 4 8 2	144	[In noise Inhibit filter]	μs	-	0 – 9999	442	
F 4 8 3	144	[In noise inhibit gain]	-	-	0.0 – 300.0	100.0	
F 4 8 4	144	[Pwr supply adj. gain]	-	-	0.0 to 2.0	0.0	
F 4 8 5	77	[Stall control coef. 1]	-	-	10 – 250	100	
F 4 9 2	77	[Stall control coef. 2]	-	-	50 – 150	100	
F 4 9 4	77	[Mot. adj coefficient]	-	-	DO NOT ADJUST	Model dependant	
F 4 9 5	77 166	[Motor voltage coef.]	%	-	90 – 120	104	
F 4 9 6	77	[PWM adj. coef.]	kHz	-	0.1 – 14.0	14.0	
F 5 0 0	93	[Acceleration time 2]	s	1	0.0 – 3200	20.0	
F 5 0 1	93	[Deceleration time 2]	s	1	0.0 – 3200	20.0	
F 5 0 2	94	[Acc/dec 1 pattern]	-	0	[Linear]	0	
				1	[S-ramp 1]		
				2	[S-ramp 2]		
F 5 0 3	94	[Acc/dec 2 pattern]	-	0	[Linear]	0	
				1	[S-pattern 1]		
				2	[S-pattern 2]		
F 5 0 4	95	[Ramp switching]	-	1	[Ramp 1]	1	
				2	[Ramp 2]		
F 5 0 5	95	[Commut. ramp freq.]	Hz	-	0.0 – [Upper limit freq] (UL)	0.0	
F 5 0 6	94	[Acc/Dec S-pat start]	%	-	0 – 50	10	
F 5 0 7	94	[Acc/Dec S-pat end]	-	-	0 – 50	10	
F 5 8 0	128	[Damper fdb type]	-	0	[No feedback]	0	
				1	[LIH set]		
				2	[LIL set]		
				3	[Com. LIH set]		
				4	[Com. LIL set]		

Code	Page	Name	Unit	Adjustment Range / Function		Factory Setting	User Setting
F 5 B 1	128	[Time open Damper]	-	-	0.05 to 300.00 s	60.00	
F 5 B 2	128	[Time close Damper]	-	-	0.05 to 300.00 s	60.00	
F 5 B 3	128	[Damper fit behavior]	-	0	[No fault]	1	
				1	[Freewheel stop]		
				2	[Ramp stop]		
F 6 0 1	73 161	[Motor Current Limit]	%/A	-	10 – 110%	110%	
F 6 0 2	138	[Drive fault memory]	-	0	[Cleared]	0	
				1	[Retained]		
F 6 0 3	126	[Ext. fault stop Mode]	-	0	[Freewheel]	0	
				1	[Ramp stop]		
				2	[DC braking]		
F 6 0 4	126	[DC brk time ext flt]	s	-	0.0 – 20.0	1.0	
F 6 0 5	140	[Output phase loss]	-	0	[Disabled]	3	
				1	[First start]		
				2	[Each start]		
				3	[During run]		
				4	[Permanent]		
F 6 0 7	74	[Mot overload time]	s	-	10 – 2400	300	
F 6 0 8	138	[Input phase loss]	-	0	[Disable]	1	
				1	[Enable]		
F 6 0 9	141	[Underload band]	%	-	1 – 20	10	
F 6 1 0	141	[Underload det.]	-	0	[Alarm]	0	
				1	[Fault]		
F 6 1 1	141	[Underload level]	%/A	-	0 – 100%	0	
F 6 1 2	141	[Underload det. time]	s	-	0 – 255	0	
F 6 1 3	142	[Short circuit det.]	-	0	[Each time (std)]	0	
				1	[One time (std)]		
				2	[Each time (short)]		
				3	[One time (short)]		
F 6 1 5	143	[Overtorque det.]	-	0	[Alarm]	0	
				1	[Fault]		
F 6 1 6	143	[Overtorque level]	%	-	0 – 250	130	
F 6 1 8	143	[OvTorque det time]	s	-	0.0 – 10.0	0.5	
F 6 1 9	143	[Overtorque band]	%	-	0 – 100%	10	
F 6 2 1	130	[Run time alarm]	h	-	0.0 – 999.9 (0.1 = 1 hour, 100 = 1000 hours)	610.0	
F 6 2 6	139	[Overvoltage level]	%	1	[100 – 150% of nominal DC bus voltage]	140	
F 6 2 7	138	[Undervolt detect.]	-	0	[Alarm (0.6U)]	0	
				1	[Fault (0.6U)]		
				2	[Alarm (0.5U)]		
F 6 3 2	137	[Mot overload memo]	-	0	[Disabled]	0	
				1	[Enabled]		
F 6 3 3	141	[Loss of VIA]	%	0	[Disabled]	0	
				1-100	[Fault detection level]		
F 6 3 4	144	[Amb. temp. alarm]	-	1	[-10 to 10°C]	3	
				2	[11 to 20°C]		
				3	[21 to 30°C]		
				4	[31 to 40°C]		
				5	[41 to 50°C]		
				6	[51 to 60°C]		
F 6 4 4	142	[4-20 mA loss]	-	0	[No]	0	
				1	[Freewheel]		
				2	[Set speed]		
				3	[Keep speed]		
				4	[Ramp stop]		
F 6 4 5	122	[Mot PTC selection]	-	0	[Disabled]	0	
				1	[Enabled fault]		
				2	[Enabled alarm]		

Code	Page	Name	Unit	Adjustment Range / Function		Factory Setting	User Setting
F 6 4 6	122	[PTC resistor value]	Ω	-	100 – 9999	3000	
F 6 4 9	142	[4-20mA fallback sp]	Hz	-	0 – [Max frequency] (F H) Hz	0	
F 6 5 0	89	[Forced fire control]	-	0	[Disable]	0	
				1	[Enable forward]		
				2	[Enable Reverse]		
F 6 5 9	89	[Forced fire function]	-	0	[Enable transition "0->1"]	0	
				1	[Enable level 1]		
				2	[Enable level 0]		
F 6 9 1	119	[AO slope]	-	0	[Negative slope]	1	
				1	[Positive slope]		
F 6 9 2	119	[Analog output bias]	%	-	0 – 100%	0	
F 6 9 4	119	[Freq. for AO = 0V]	Hz	-	0 – [Max frequency] (F H) Hz	0	
F 6 9 5	119	[Freq. for AO = 10V]	Hz	-	0 – [Max frequency] (F H) Hz	0	
F 7 0 0	68	[Parameter lock]	-	0	[Unlocked]	0	
				1	[Locked]		
F 7 0 1	130	[Unit value selection]	-	0	[%]	1	
				1	[Amp or Volt]		
F 7 0 2	131	[Customized freq val]	-	0	Frequency displayed in Hz	0	
				0.01 – 200.0	Conversion factor		
F 7 0 3	131	[Frequency convert.]	-	0	[All]	0	
				1	[PID only]		
F 7 0 5	131	[Custom freq. slope]	-	0	[Negative slope]	1	
				1	[Positive slope]		
F 7 0 6	131	[Customize unit bias]	Hz	-	0.00 – [Max frequency] (F H)	0.00	
F 7 0 7	87	[Loc. speed ref. step]	Hz	0	[Disable]	0.00	
				1	[Enable]		
F 7 0 8	130	[Display ref. resol.]	-	0	Disabled – 0.1 Hz steps	0	
				1 – 255	See formula on page 130		
F 7 1 0	130	[Displayed param.]	-	0	[Motor frequency]	0	
				1	[Reference]		
				2	[I Mot]		
				3	[Drive rated I]		
				4	[Drive therm state]		
				5	[Motor power]		
				6	[Int speed ref]		
				7	[Com data]		
				8	[Motor speed]		
				9	[Com count]		
F 7 2 1	88	[Loc. mot stop mode]	-	0	[Ramp stop]	0	
				1	[Freewheel]		
F 7 3 0	90	[Up/down key ref]	-	0	[Enable]	0	
				1	[Disable]		
F 7 3 2	90	[Loc/rem key]	-	0	[Permitted memo]	0	
				1	[Prohibited]		
				2	[Permitted no memo]		
F 7 3 3	90	[Run/stop key]	-	0	[Enable]	0	
				1	[Disable]		
F 7 3 4	90	[Priority stop]	-	0	[Enable]	0	
				1	[Disable]		
F 7 3 5	90	[HMI reset button]	-	0	[Disable]	1	
				1	[Enable]		
F 7 3 8	68	[Quick menu AUF]	-	0	[AUF displayed]	0	
				1	[AUF hidden]		
F 7 4 8	130	[Power cons. memo]	-	0	[Disable]	Model dependant	
				1	[Enable]		

Code	Page	Name	Unit	Adjustment Range / Function		Factory Setting	User Setting
F 749	131	[Power cons. unit]	kWh	0	[1 kWh]	Model dependant	
				1	[0.1 kWh]		
				2	[0.01 kWh]		
				3	[0.001 kWh]		
F 800	148	[Mdb RJ45 baud]	-	0	[9600 bps]	1	
				1	[19200 bps]		
F 801	148	[Mdb RJ45 parity]	-	0	[No]	1	
				1	[Even]		
				2	[Odd]		
F 802	148	[Modbus address]	-	-	0 – 247	1	
F 803	149	[Com. time out]	s	0	Communication error detection disabled	3	
				1-100	1 to 100 seconds		
F 807	149	[Com channel choice]	-	0	[RJ45]	1	
				1	[Open style]		
F 820	149	[Mdb network baud]	-	0	[9600]	1	
				1	[19200]		
F 821	149	[Mdb network parity]	s	0	[No]	1	
				1	[Even]		
				2	[Odd]		
F 829	149	[Network protocol]	-	1	[Mdb RTU]		
				2	[Metasys N2]		
				3	[Apogee P1]		
				4	[BACnet]		
				5	[LonWorks]		
F 851	149	[Com. fault setting]	-	0	[Ramp stp (F/Cmod)]	4	
				1	[No active]		
				2	[Ramp stop]		
				3	[Freewheel]		
F 856	150	[Mot. poles (comm.)]	-	1	[2 poles]	2	
				2	[4 poles]		
				3	[6 poles]		
				4	[8 poles]		
				5	[10 poles]		
				6	[12 poles]		
				7	[14 poles]		
				8	[16 poles]		
F 870	150	[Block write data 1]	-	0	[No select]	0	
				1	[Command word 1]		
				2	[Command word 2]		
				3	[Frequency Setpoint]		
				4	[Relay command]		
				5	[FM command]		
F 871	150	[Block write data 2]	-	0	[No select]	0	
				1	[Command word 1]		
				2	[Command word 2]		
				3	[Frequency Setpoint]		
				4	[Relay command]		
				5	[FM command]		
F 875	150	[Block read data 1]	-	0	[No select]	0	
				1	[Command 1]		
				2	[Freq. out]		
				3	[Motor current]		
				4	[Output volt]		
				5	[Alarm info]		
				6	[PID feedback value]		
				7	[Input term. mon]		
				8	[Out term. mon]		
				9	[VIA monitor]		
				10	[VIB monitor]		
11	[Mot speed mon.]						

Code	Page	Name	Unit	Adjustment Range / Function		Factory Setting	User Setting
FB 76	150	[Block read data 2]	-	0	[No select]	0	
				1	[Command 1]		
				2	[Freq. out]		
				3	[Motor current]		
				4	[Output volt]		
				5	[Alarm info]		
				6	[PID feedback value]		
				7	[Input term. mon]		
				8	[Out term. mon]		
				9	[VIA monitor]		
				10	[VIB monitor]		
11	[Mot speed mon.]						
FB 77	151	[Block read data 3]	-	0	[No select]	0	
				1	[Status info]		
				2	[Freq. out]		
				3	[Motor current]		
				4	[Output volt]		
				5	[Alarm info]		
				6	[PID feedback value]		
				7	[Input term. mon]		
				8	[Out term. mon]		
				9	[VIA monitor]		
				10	[VIB monitor]		
11	[Mot speed mon.]						
FB 78	151	[Block read data 4]	-	0	[No select]	0	
				1	[Status info]		
				2	[Freq. out]		
				3	[Motor current]		
				4	[Output volt]		
				5	[Alarm info]		
				6	[PID feedback value]		
				7	[Input term. mon]		
				8	[Out term. mon]		
				9	[VIA monitor]		
				10	[VIB monitor]		
11	[Mot speed mon.]						
FB 79	151	[Block read data 5]	-	0	[No select]	0	
				1	[Status info]		
				2	[Freq. out]		
				3	[Motor current]		
				4	[Output volt]		
				5	[Alarm info]		
				6	[PID feedback value]		
				7	[Input term. mon]		
				8	[Out term. mon]		
				9	[VIA monitor]		
				10	[VIB monitor]		
11	Mot speed mon.						
FB 80	151	[Free ID parameter]	-	-	0 – 65535	0	
FB 90	152	[Network adress]	-	-	0 – 65535	(1)	
FB 91	152	[Network baud rate]	-	-	0 – 65535	(1)	
FB 92	152	[Network time out]	-	-	20 - 600	(1)	
FB 93	152	[Instance number H]	-	-	0 – 4194	(1)	
FB 94	152	[Instance number L]	-	-	0 – 999	(1)	
FB 95	152	[Max master]	-	-	0 – 127	(1)	
FB 96	152	[Max info frames]	-	-	0 – 100	(1)	
F 9 12	85	[Autotune L q-axis]	-	-	0 – 650	10	
F 9 13	85	[Autotune L d-axis]	-	-	0 – 650	10	
F 9 14	86	[N-S direction]	-	0	[0]	0	
				1	[1]		

Code	Page	Name	Unit	Adjustment Range / Function		Factory Setting	User Setting
<i>F 9 15</i>	<u>166</u>	[PM mode selection]	-	<i>0</i>	[0]	3	
				<i>1</i>	[1]		
				<i>2</i>	[2]		
				<i>3</i>	[3]		
				<i>4</i>	[4]		
<i>F 9 16</i>	<u>85</u>	[PM Align cur. Level]	%	-	0 – 100	25	
<i>F 9 17</i>	<u>86</u>	[PM Max torq. Ctrl]	-	<i>0</i>	[0]	1	
				<i>1</i>	[1]		
<i>F 9 18</i>	<u>86</u>	[Cur. phase adjt]	-	-	-45 – 45.0	0.0	
<i>F 9 20</i>	<u>86</u>	[Position Adjust]	%	-	0 – 150	0	
<i>F 9 21</i>	<u>85</u>	[Init. Pos. Current]	%	-	10 – 150	0.0	
<i>F 9 36</i>	<u>84</u>	[Saliency Level]	-	-	0 – 2.55	0	

(1) See table page [152](#).

