

# Altivar 212

Variable speed drives  
for synchronous and asynchronous motors

02/2026



---

The information provided in this documentation contains general descriptions and/or technical characteristics of the performance of the products contained herein. This documentation is not intended as a substitute for and is not to be used for determining suitability or reliability of these products for specific user applications. It is the duty of any such user or integrator to perform the appropriate and complete risk analysis, evaluation and testing of the products with respect to the relevant specific application or use thereof. Neither Schneider Electric nor any of its affiliates or subsidiaries shall be responsible or liable for misuse of the information contained herein. If you have any suggestions for improvements or amendments or have found errors in this publication, please notify us.

You agree not to reproduce, other than for your own personal, noncommercial use, all or part of this document on any medium whatsoever without permission of Schneider Electric, given in writing. You also agree not to establish any hypertext links to this document or its content. Schneider Electric does not grant any right or license for the personal and noncommercial use of the document or its content, except for a non-exclusive license to consult it on an "as is" basis, at your own risk. All other rights are reserved.

All pertinent state, regional, and local safety regulations must be observed when installing and using this product. For reasons of safety and to help ensure compliance with documented system data, only the manufacturer should perform repairs to components.

When devices are used for applications with technical safety requirements, the relevant instructions must be followed.

Failure to use Schneider Electric software or approved software with our hardware products may result in injury, harm, or improper operating results.

Failure to observe this information can result in injury or equipment damage.

© 2026 Schneider Electric. All rights reserved.

# Table of Contents



	<b>Safety Information</b> .....	<b>5</b>
	<b>About the Book</b> .....	<b>9</b>
	Device overview .....	<b>14</b>
	Reference description .....	<b>15</b>
	Green Premium™ .....	<b>15</b>
<b>Chapter 1</b>	<b>Before You Begin</b> .....	<b>17</b>
	Lifting and handling instructions .....	<b>18</b>
<b>Chapter 2</b>	<b>Steps for Setting Up</b> .....	<b>19</b>
	Steps for setting up .....	<b>20</b>
<b>Chapter 3</b>	<b>Upstream Protective Device</b> .....	<b>21</b>
	Prospective Short-Circuit Current .....	<b>24</b>
	IEC Fuses - With enclosure .....	<b>26</b>
	IEC Fuses - Wall mounted .....	<b>29</b>
	UL Circuit-Breakers and Fuses .....	<b>32</b>
<b>Chapter 4</b>	<b>Technical Data</b> .....	<b>33</b>
	ATV212H dimensions and weights .....	<b>34</b>
	ATV212W dimensions and weights .....	<b>36</b>
	Electrical data .....	<b>37</b>
	Connection diagrams .....	<b>39</b>
	Examples of recommended circuit diagrams .....	<b>40</b>
<b>Chapter 5</b>	<b>Installation</b> .....	<b>41</b>
	Drive mounting generalities .....	<b>42</b>
	Specific recommendations for mounting in an enclosure .....	<b>51</b>
	Position of the charging LED .....	<b>52</b>
	Opening the drive to access terminals .....	<b>52</b>
	Wiring recommendations .....	<b>55</b>
	Power terminals .....	<b>57</b>
	Control terminals and switches .....	<b>62</b>
	Installing option card .....	<b>65</b>
	Use on an impedance grounded (IT) system .....	<b>66</b>
	Electromagnetic compatibility (EMC) .....	<b>69</b>
	Checking the Installation .....	<b>73</b>
	Recommended branch circuit protection devices .....	<b>74</b>
<b>Chapter 6</b>	<b>Maintenance</b> .....	<b>75</b>
	Scheduled Servicing .....	<b>76</b>
	Long-term Storage .....	<b>77</b>
	Decommissioning .....	<b>77</b>
	Additional Support .....	<b>77</b>
<b>Chapter 7</b>	<b>Migration ATV21 --&gt; ATV212</b> .....	<b>79</b>
	Generalities .....	<b>80</b>
	Differentiating points .....	<b>80</b>
	Terminal and switches arrangement comparison .....	<b>81</b>





## Important Information

### NOTICE

Read these instructions carefully, and look at the equipment to become familiar with the device before trying to install, operate, service, or maintain it. The following special messages may appear throughout this documentation or on the equipment to warn of potential hazards or to call attention to information that clarifies or simplifies a procedure.



The addition of this symbol to a “Danger” or “Warning” safety label indicates that an electrical hazard exists which will result in personal injury if the instructions are not followed.



This is the safety alert symbol. It is used to alert you to potential personal injury hazards. Obey all safety messages that follow this symbol to avoid possible injury or death.

### **DANGER**

**DANGER** indicates a hazardous situation which, if not avoided, **will result in** death or serious injury.

### **WARNING**

**WARNING** indicates a hazardous situation which, if not avoided, **could result in** death or serious injury.

### **VORSICHT**

**VORSICHT** macht auf eine gefährliche Situation aufmerksam, die, wenn sie nicht vermieden wird, leichte Verletzungen **zur Folge haben kann**.

### **HINWEIS**

**HINWEIS** gibt Auskunft über Vorgehensweisen, bei denen keine Verletzungen drohen.

### PLEASE NOTE

Electrical equipment should be installed, operated, serviced, and maintained only by qualified personnel. No responsibility is assumed by Schneider Electric for any consequences arising out of the use of this material.

A qualified person is one who has skills and knowledge related to the construction and operation of electrical equipment and its installation, and has received safety training to recognize and avoid the hazards involved.

### Qualification Of Personnel

Only appropriately trained persons who are familiar with and understand the contents of this manual and all other pertinent product documentation are authorized to work on and with this product. In addition, these persons must have received safety training to recognize and avoid hazards involved. These persons must have sufficient technical training, knowledge and experience and be able to foresee and detect potential hazards that may be caused by using the product, by changing the settings and by the mechanical, electrical and electronic equipment of the entire system in which the product is used. All persons working on and with the product must be fully familiar with all applicable standards, directives, and accident prevention regulations when performing such work.

## Intended Use

This product is a drive for three-phase synchronous, asynchronous motors and intended for industrial use according to this manual. The product may only be used in compliance with all applicable safety standard and local regulations and directives, the specified requirements and the technical data. The product must be installed outside the hazardous ATEX zone. Prior to using the product, you must perform a risk assessment in view of the planned application. Based on the results, the appropriate safety measures must be implemented. Since the product is used as a component in an entire system, you must ensure the safety of persons by means of the design of this entire system (for example, machine design). Any use other than the use explicitly permitted is prohibited and can result in hazards.

## Product Related Information

**Read and understand these instructions before performing any procedure with this drive.**

 **DANGER**

**HAZARD OF ELECTRIC SHOCK, EXPLOSION OR ARC FLASH**

- Only appropriately trained persons who are familiar with and understand the contents of this manual and all other pertinent product documentation and who have received safety training to recognize and avoid hazards involved are authorized to work on and with this drive system. Installation, adjustment, repair and maintenance must be performed by qualified personnel.
- The system integrator is responsible for compliance with all local and national electrical code requirements as well as all other applicable regulations with respect to grounding of all equipment.
- Many components of the product, including the printed circuit boards, operate with mains voltage.
- Only use properly rated, electrically insulated tools and measuring equipment.
- Do not touch unshielded components or terminals with voltage present.
- Motors can generate voltage when the shaft is rotated. Prior to performing any type of work on the drive system, block the motor shaft to prevent rotation.
- AC voltage can couple voltage to unused conductors in the motor cable. Insulate both ends of unused conductors of the motor cable.
- Do not short across the DC bus terminals or the DC bus capacitors or the braking resistor terminals.
- Before performing work on the drive system:
  - Disconnect all power, including external control power that may be present. Take into account that the circuit breaker or main switch does not de-energize all circuits.
  - Place a **Do Not Turn On** label on all power switches related to the drive system.
  - Lock all power switches in the open position.
  - Wait 15 minutes to allow the DC bus capacitors to discharge.
  - Measure the voltage on the DC bus between the DC bus terminals (PA/+ and PC/-) using a properly rated voltmeter to verify that the voltage is <42 Vdc.
  - If the DC bus capacitors do not discharge properly, contact your local Schneider Electric representative. Do not repair or operate the product.
- Install and close all covers before applying voltage.

**Failure to follow these instructions will result in death or serious injury.**

Damaged products or accessories may cause electric shock or unanticipated equipment operation.

 **DANGER**

**ELECTRIC SHOCK OR UNANTICIPATED EQUIPMENT OPERATION**

Do not use damaged products or accessories.

**Failure to follow these instructions will result in death or serious injury.**

Contact your local Schneider Electric sales office if you detect any damage whatsoever.

This equipment has been designed to operate outside of any hazardous location. Only install this equipment in zones known to be free of a hazardous atmosphere.

## DANGER

### POTENTIAL FOR EXPLOSION

Install and use this equipment in non-hazardous locations only.

**Failure to follow these instructions will result in death or serious injury.**

Drive systems may perform unexpected movements because of incorrect wiring, incorrect settings, incorrect data or other errors.

## WARNING

### UNANTICIPATED EQUIPMENT OPERATION

- Carefully install the wiring in accordance with the EMC requirements.
- Do not operate the product with unknown or unsuitable settings or data.
- Perform a comprehensive commissioning test.

**Failure to follow these instructions can result in death, serious injury, or equipment damage.**

## WARNING

### LOSS OF CONTROL

- The designer of any control scheme must consider the potential failure modes of control paths and, for critical control functions, provide a means to achieve a safe state during and after a path failure. Examples of critical control functions are emergency stop, overtravel stop, power outage and restart.
- Separate or redundant control paths must be provided for critical control functions.
- System control paths may include communication links. Consideration must be given to the implications of unanticipated transmission delays or failures of the link.
- Observe all accident prevention regulations and local safety guidelines (1).
- Each implementation of the product must be individually and thoroughly tested for proper operation before being placed into service.

**Failure to follow these instructions can result in death, serious injury, or equipment damage.**

(1) For USA: Additional information, refer to NEMA ICS 1.1 (latest edition), Safety Guidelines for the Application, Installation, and Maintenance of Solid State Control and to NEMA ICS 7.1 (latest edition), Safety Standards for Construction and Guide for Selection, Installation and Operation of Adjustable-Speed Drive Systems.

The temperature of the products described in this manual may exceed 80 °C (176 °F) during operation.

## WARNING

### HOT SURFACES

- Ensure that any contact with hot surfaces is avoided.
- Do not allow flammable or heat-sensitive parts in the immediate vicinity of hot surfaces.
- Verify that the product has sufficiently cooled down before handling it.
- Verify that the heat dissipation is sufficient by performing a test run under maximum load conditions.

**Failure to follow these instructions can result in death, serious injury, or equipment damage.**

---

## ***NOTICE***

### **DESTRUCTION DUE TO INCORRECT MAINS VOLTAGE**

Before switching on and configuring the product, verify that it is approved for the mains voltage.

**Failure to follow these instructions can result in equipment damage.**

---

# About the Book



## At a Glance

### Document Scope

The purpose of this document is:

- to give you mechanical and electrical information related to the Altivar 212 drive,
- to show you how to install and wire this drive.

### Validity Note

Original instructions and information given in the present document have been written in English (before optional translation).

**NOTE:** The products listed in the document are not all available at the time of publication of this document online. The data, illustrations and product specifications listed in the guide will be completed and updated as the product availabilities evolve. Updates to the guide will be available for download once products are released on the market.

This documentation is valid for the Altivar 212 drive.

The technical characteristics of the devices described in the present document also appear online. To access the information online:

Step	Action
1	Go to the Schneider Electric home page <a href="http://www.se.com">www.se.com</a> .
2	In the <b>Search</b> box type the reference of a product or the name of a product range. <ul style="list-style-type: none"><li>● Do not include blank spaces in the reference or product range.</li><li>● To get information on grouping similar modules, use asterisks (*).</li></ul>
3	If you entered a reference, go to the <b>Product Datasheets</b> search results and click on the reference that interests you. If you entered the name of a product range, go to the <b>Product Ranges</b> search results and click on the product range that interests you.
4	If more than one reference appears in the <b>Products</b> search results, click on the reference that interests you.
5	Depending on the size of your screen, you may need to scroll down to see the data sheet.
6	To save or print a data sheet as a .pdf file, click <b>Download XXX product datasheet</b> .

The characteristics that are presented in the present document should be the same as those characteristics that appear online. In line with our policy of constant improvement, we may revise content over time to improve clarity and accuracy. If you see a difference between the document and online information, use the online information as your reference.

### Related Documents

Use your tablet or your PC to quickly access detailed and comprehensive information on all our products on [www.se.com](http://www.se.com).

The internet site provides the information you need for products and solutions:

- The whole catalog for detailed characteristics and selection guides,
- The CAD files to help design your installation, available in over 20 different file formats,
- All software and firmware to maintain your installation up to date,
- A large quantity of White Papers, Environment documents, Application solutions, Specifications... to gain a better understanding of our electrical systems and equipment or automation,

- And finally all the User Guides related to your drive, listed below:

Title of Documentation	Catalog Number
ATV212 Quick Start guide	<a href="#">S1A53825</a> (English), <a href="#">S1A53826</a> (French), <a href="#">S1A53827</a> (German), <a href="#">S1A53828</a> (Spanish), <a href="#">S1A53830</a> (Italian), <a href="#">S1A53831</a> (Chinese)
ATV212 Quick Start guide - Annex	<a href="#">S1A73476</a> (English)
ATV212 Installation manual	<a href="#">S1A53832</a> (English), <a href="#">S1A53833</a> (French), <a href="#">S1A53834</a> (German), <a href="#">S1A53836</a> (Spanish), <a href="#">S1A53835</a> (Italian), <a href="#">SCDOC1563</a> (Chinese)
ATV212 Programming manual	<a href="#">S1A53838</a> (English), <a href="#">S1A53839</a> (French), <a href="#">S1A53840</a> (German), <a href="#">S1A53842</a> (Spanish), <a href="#">S1A53841</a> (Italian), <a href="#">SCDOC1564</a> (Chinese)
ATV212 Catalog	<a href="#">DIA2ED2101102EN</a> (English)
ATV212 Modbus manual	<a href="#">S1A53844</a> (English)
ATV32 Profinet manual	<a href="#">HRB25668</a> (English)
ATV212 BACnet manual	<a href="#">S1A53845</a> (English)
ATV212 Metasys N2 manual	<a href="#">S1A53846</a> (English)
ATV212 Apogee FLN P1 manual	<a href="#">S1A53847</a> (English)
ATV212 LONWORKS manual	<a href="#">S1A53848</a> (English)
Multiloader manual	<a href="#">BBV48778</a> (English)
SoMove: FDT	<a href="#">SoMove_FDT</a> (English, French, German, Spanish, Italian, Chinese)
Altivar DTM	<a href="#">Altivar_DTM_Library</a> (English, French, German, Spanish, Italian, Chinese)
ATV212 other option manuals: see <a href="http://www.se.com">www.se.com</a>	

You can download these technical publications and other technical information from our website at [www.se.com/en/download](http://www.se.com/en/download)

## Electronic Product Data sheet

Scan the QR code in front of the drive to get the product data sheet.

## Terminology

The technical terms, terminology, and the corresponding descriptions in this manual normally use the terms or definitions in the relevant standards.

In the area of drive systems this includes, but is not limited to, terms such as **error**, **error message**, **failure**, **fault**, **fault reset**, **protection**, **safe state**, **safety function**, **warning**, **warning message**, and so on.

Among others, these standards include:

- IEC 61800 series: Adjustable speed electrical power drive systems
- IEC 61508 Ed.2 series: Functional safety of electrical/electronic/programmable electronic safety-related
- EN 954-1 Safety of machinery - Safety related parts of control systems
- ISO 13849-1 & 2 Safety of machinery - Safety related parts of control systems
- IEC 61158 series: Industrial communication networks - Fieldbus specifications
- IEC 61784 series: Industrial communication networks - Profiles
- IEC 60204-1: Safety of machinery - Electrical equipment of machines – Part 1: General requirements

In addition, the term **zone of operation** is used in conjunction with the description of specific hazards, and is defined as it is for a **hazard zone** or **danger zone** in the EC Machinery Directive (2006/42/EC) and in ISO 12100-1.

Also see the glossary at the end of this manual.

---

## Contact Us

Select your country on:

[www.se.com/contact](http://www.se.com/contact)

### **Schneider Electric Industries SAS**

Head Office

35, rue Joseph Monier

92500 Rueil-Malmaison

France



---

# Chapter 1

## Introduction

---

### What's in this Chapter?

This chapter contains the following topics:

Topic	Page
Device overview	14
Reference description	15
Green Premium™	15

## Device overview

### The product

The ATV212 drive is mainly dedicated to HVAC applications in Building sector. The ATV212 drive family consists of five IP21 and two IP55 product sizes

### The IP21 «H» range - 5 drive sizes - Three-phase 50/60 Hz supply voltage

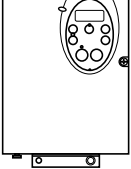
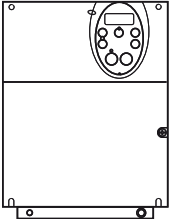
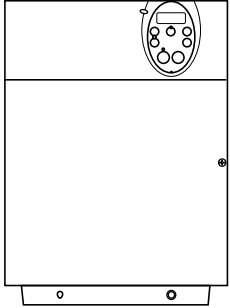
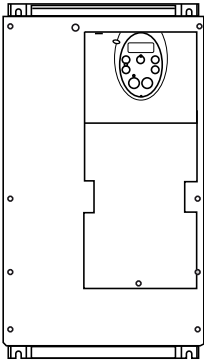
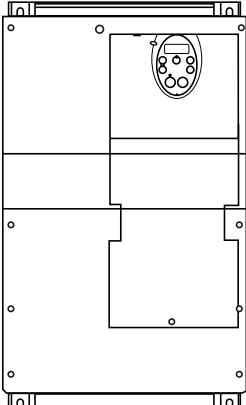
ATV212H075M3X, U15M3X, U22M3X, 075N4, U15N4, U22N4, U30M3X, U40M3X, U30N4, U40N4, U55N4	ATV212HU55M3X, U75M3X, U75N4, D11N4	ATV212HD11M3X, D15M3X, D15N4, D18M3X, D18N4, D22N4S
0.75 to 5.5 kW	5.5 to 11 kW	11 to 22 kW
		
ATV212HD22M3X, D22N4, D30N4, D37N4, D45N4	ATV212HD30M3X, D55N4, D75N4	
22 to 45 kW	30 to 75 kW	
		

### The IP55 «W» range - 2 drive sizes - Three-phase 50/60 Hz supply voltage

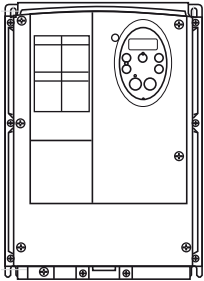
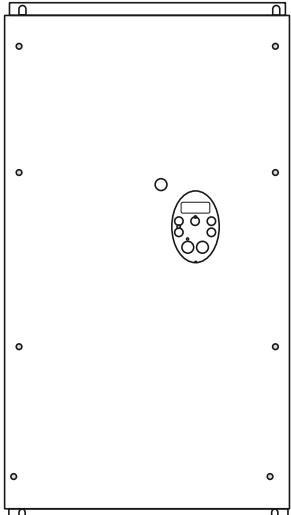
ATV212W075N4...U22N4, U30N4...U75N4	ATV212WD11N4...D75N4
0.75 to 7.5 kW	11 to 75 kW
	

## Reference description

### IP21 and IP55 variable speed drives - Three-phase 50/60 Hz supply voltage: 200 ... 240 V and 380 ... 480 V

	ATV	212	H	D30	N4	S
<b>Product designation</b> ATV - Altivar						
<b>Product range</b>						
<b>Degree of protection</b> H - IP21 product W - IP55 product						
<b>Drive rating</b> 075 - 0.75 kW (1 HP) U15 - 1.5 kW (2 HP) U22 - 2.2 kW (3 HP) U30 - 3 kW U40 - 4 kW (5 HP) U55 - 5.5 kW (7 <sup>1/2</sup> HP) U75 - 7.5 kW (10 HP) D11 - 11 kW (15 HP) D15 - 15 kW (20 HP) D18 - 18.5 kW (25 HP) D22 - 22 kW (30 HP) D30 - 30 kW (40 HP)						
D37 - 37 kW (50 HP) D45 - 45 kW (60 HP) D55 - 55 kW (75 HP) D75 - 75 kW (100 HP)						
						<b>380 - 480 V range only</b>
<b>Power supply voltage</b> M3X: 200 - 240 V range three-phase N4: 380 - 480 V range three-phase (With integrated EMC filter C2, C3) N4C: 380 - 480 V range three-phase (With integrated C1 EMC filter for UL Type 12/IP55 products ATV212W●●●●●●)						
<b>Slim version</b> N4S: Available for 22 kW (30 HP) rating, IP21 version						

## Green Premium™

### Description

Information on the environmental impact of products, their resource efficiency, and end-of-life instructions.

### Easy access to information: "Check Your Product"

Certificates and relevant product information available at the address:

[www.se.com/green-premium](http://www.se.com/green-premium)

You can download RoHS and REACH compliance declarations, Product Environmental Profiles (PEP) and End-of-Life instructions (EoLi).





---

## Chapter 2

### Before You Begin

---

#### What's in this Chapter?

This chapter contains the following topics:

Topic	Page
Lifting and handling instructions	18

## Lifting and handling instructions

### ▲WARNING

#### HANDLING AND LIFTING HAZARD

Keep the area below any equipment being lifted clear of all personnel and property. Use the lifting method illustrated in following figure.

**Failure to follow these instructions can result in death, serious injury, or equipment damage.**

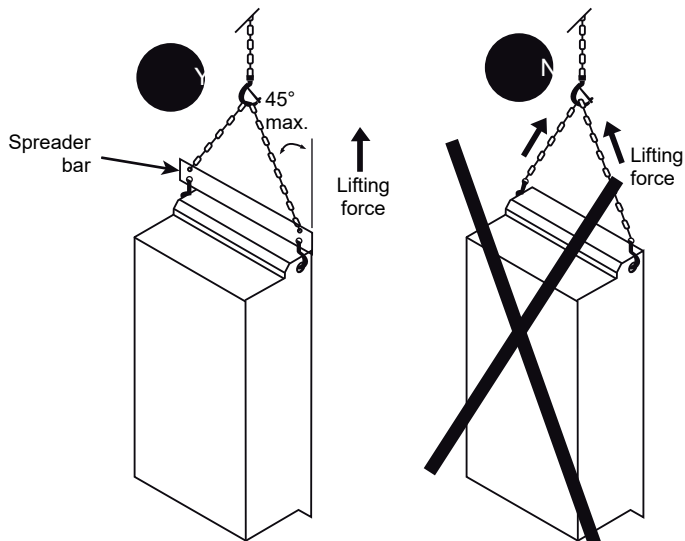

- Altivar 212 drives up to ATV212HD22N4S and ATV212W075N4 can be removed from their packaging and installed without a handling device.
- A hoist must be used for higher ratings.
- After removing the drive from its packaging, inspect it for damage. If any damage is found, notify the carrier and your sales representative.
- Verify that the drive nameplate and label conform to the packing slip and corresponding purchase order.

### ▲WARNING

#### RISK OF TOPPLING

- Keep the drive on the pallet until ready to install.
- Never place the drive in an upright position without proper support, such as a hoist, braces, or other mounting supports.

**Failure to follow these instructions can result in death, serious injury, or equipment damage.**

## Storing and shipping

If the drive is not immediately installed, store it in a clean, dry area where the ambient temperature is between  $-25$  and  $+70$  °C ( $-13$  to  $+158$  °F). If the drive has to be shipped to another location, use the original shipping material and carton to help protect the drive.

If the drive was not connected to mains for an extended period of time, the capacitors must be restored to their full performance before the motor is started.

### NOTICE

#### REDUCED CAPACITOR PERFORMANCE

- Apply mains voltage to the drive for one hour before starting the motor if the drive has not been connected to mains for the specified periods of time (1).
- Verify that no Run command can be applied before the period of one hour has elapsed.
- Verify the date of manufacture if the drive is commissioned for the first time and run the specified procedure if the date of manufacture is more than 12 months in the past.

**Failure to follow these instructions can result in equipment damage.**

(1) Period of time:

- 12 months at a maximum storage temperature of  $+50$ °C ( $+122$ °F)
- 24 months at a maximum storage temperature of  $+45$ °C ( $+113$ °F)
- 36 months at a maximum storage temperature of  $+40$ °C ( $+104$ °F)

If the specified procedure cannot be performed without a Run command because of internal mains contactor control, perform this procedure with the power stage enabled, but the motor being at standstill so that there is no appreciable mains current in the capacitors.

---

# Chapter 3

## Steps for Setting Up

---

### What's in this Chapter?

This chapter contains the following topics:

Topic	Page
Steps for setting up	20

## INSTALLATION

### 1. Check the delivery of the drive

- Check that the part number printed on the label is the same as that on the purchase order.
- Remove the Altivar from its packaging and check that it has not been damaged in transit.

### 2. Check the line voltage compatibility

- Check that the voltage range of the drive is compatible with the supply voltage (see page 37).

Steps 1 to 4 must be performed with the **power off**.



### 3. Mount the drive vertically

- Mount the drive in accordance with the instructions in this document (see page 42).
- Install any options required (see option documentation).

### 4. Wire the drive (see page 55)

- Connect the line supply and the ground, after making sure that the power is off.
- Connect the motor, ensuring that its connections correspond to the voltage.
- Connect the control part.

## PROGRAMMING

5. Please refer to the programming manual.

---

# Chapter 4

## Upstream Protective Device

---

### What Is in This Chapter?

This section contains the following topics:

Topic	Page
Introduction	22
Prospective Short-Circuit Current	24
IEC Type Circuit-Breaker as SCPD	26
IEC Fuses	26
UL Circuit-Breakers and Fuses	28

## Introduction

### Overview

#### **DANGER**

##### **INSUFFICIENT PROTECTION AGAINST OVERCURRENTS CAN CAUSE FIRE OR EXPLOSION**

- Use properly rated overcurrent protection devices.
- Use the fuses/circuit breakers specified.
- Do not connect the product to a supply mains whose prospective short circuit current rating (current that flows during a short circuit) exceeds the specified maximum permissible value.
- When rating the upstream mains fuses and the cross sections as well as the lengths of the mains cables, take into account the minimum required prospective short-circuit current (Isc). Refer to the Upstream Protection Device section.
- If the minimum required prospective short-circuit current (Isc) is not available, apply the instructions given in the section below.

**Failure to follow these instructions will result in death or serious injury.**

The specified maximum permissible values and products for IEC compliance are specified in the catalog.

The specified maximum permissible values and products for UL/CSA compliance are specified in the ATV212 Quick Start Guide Annex (S1A73476) provided with the product.

### General

- The Short Circuit Protective Device (SCPD) rated to the drive will help protect the upstream installation in case of a short-circuit internal to the drive and mitigate the damage to the drive and its surrounding area.
- The SCPD rated to the drive is mandatory to help ensuring the safety of the Power Drive System. It comes in addition to the upstream branch circuit protection which is in compliance with the local regulation for electrical installation.
- The SCPD shall mitigate the damage in case of detected error condition such as an internal short-circuit of the drive.
- The SCPD must take into account both following characteristics...
  - a maximum prospective short-circuit current
  - a minimum required prospective short-circuit current (Isc).

If the minimum required prospective short-circuit current (Isc) is not available, increase the power of the transformer or decrease the length of the cables

In other cases, contact your Schneider Electric Customer Care Center (CCC) <https://www.se.com/CCC> for specific selection of Short Circuit Protective Device (SCPD).

**Note:** The electronic power output short-circuit protection circuitry meets the requirements of IEC 60364-4-41:2005/AMD1 - Clause 411.

## Wiring Diagram

This diagram shows an example of installation with both SCPD types, Circuit-breaker ([see page 26](#)) and Fuse link ([see page 26](#)) rated to the drive.

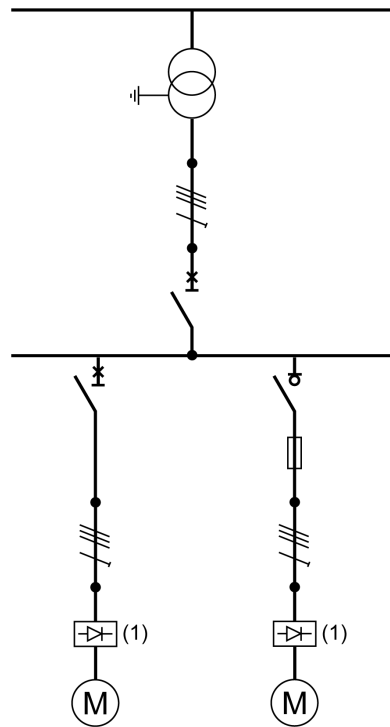

(1) Drive

---

## Prospective Short-Circuit Current

### Calculation

The prospective short-circuit current shall be computed at the drive connection points.



We recommend using the Schneider Electric tool EcoStruxure Power Design - Ecodial available on <https://www.se.com/en/product-range/61013-ecostruxure-power-design-ecodial/#overview>

The following equations allow to estimate the value of the symmetrical three-phase prospective short-circuit current ( $I_{sc}$ ) at the drive connection points.

$$X_t = \frac{U^2}{S_n} \cdot usc$$

$$Z_{cc} = \sqrt{\left(\rho \cdot \frac{l}{S} + R_f\right)^2 + (X_t + X_c \cdot l + X_f)^2}$$

$$I_{sc} = \frac{U}{\sqrt{3}} \cdot \frac{1}{Z_{cc}}$$

<b><math>I_{sc}</math></b>	Symmetrical three-phase prospective short-circuit current (kA)
<b><math>X_t</math></b>	Transformer reactance
<b><math>U</math></b>	No-load phase to phase voltage of the transformer (V)
<b><math>S_n</math></b>	Apparent transformer power (kVA)
<b><math>usc</math></b>	Short-circuit voltage, according to the transformer data sheet (%)
<b><math>Z_{cc}</math></b>	Total short-circuit impedance (m $\Omega$ )
<b><math>\rho</math></b>	Conductor resistivity e.g. Cu: 0.01851 m $\Omega$ .mm
<b><math>l</math></b>	Conductor length (mm)
<b><math>S</math></b>	Conductor cross section (mm <sup>2</sup> )
<b><math>X_c</math></b>	Conductor lineic reactance (0.0001 m $\Omega$ /mm)
<b><math>R_f, X_f</math></b>	Resistance and reactance of the line filter (m $\Omega$ )

**Example of Calculation with Copper Cable (without line filter)**

Transformer 50 Hz	U 400 Vac Usc	Cable Cross Section	Isc depending on cable length in m(ft)							
			10 (33)	20 (66)	40 (131)	80 (262)	100 (328)	160 (525)	200 (656)	320 (1050)
kVA	%	mm <sup>2</sup> (AWG)	kA	kA	kA	kA	kA	kA	kA	kA
100	4	2.5 (14)	2.3	1.4	0.8	0.4	0.3	0.2	0.2	0.1
		4 (12)	2.9	2.0	1.2	0.6	0.5	0.3	0.2	0.2
		6 (10)	3.2	2.6	1.6	0.9	0.7	0.5	0.4	0.2
		10 (8)	3.4	3.1	2.3	1.4	1.2	0.8	0.6	0.4
		25 (4)	3.5	3.4	3.1	2.5	2.2	1.6	1.4	0.9
		50 (0)	3.5	3.5	3.3	3.0	2.8	2.3	2.1	1.5
		70 (00)	3.5	3.5	3.4	3.1	2.9	2.6	2.3	1.8
		120 (250 MCM)	3.6	3.5	3.4	3.2	3.1	2.8	2.6	2.1
250	4	6 (10)	5.7	3.4	1.8	0.9	0.7	0.5	0.4	0.2
		10 (8)	7.1	5.0	2.9	1.5	1.2	0.8	0.6	0.4
		25 (4)	8.4	7.4	5.5	3.4	2.8	1.8	1.5	0.9
		50 (0)	8.6	8.1	7.0	5.2	4.5	3.2	2.7	1.8
		70 (00)	8.6	8.2	7.3	5.8	5.2	3.9	3.3	2.3
		120 (250 MCM)	8.7	8.3	7.6	6.5	6.0	4.8	4.2	3.0
400	4	6 (10)	6.6	3.6	1.8	0.9	0.7	0.5	0.4	0.2
		10 (8)	9.2	5.6	3.0	1.5	1.2	0.8	0.6	0.4
		25 (4)	12	9.9	6.5	3.6	2.9	1.9	1.5	1.0
		50 (0)	13	12	9.3	6.1	5.1	3.4	2.8	1.8
		70 (00)	13	12	10	7.2	6.2	4.4	3.6	2.4
		120 (250 MCM)	13	13	11	8.6	7.6	5.7	4.9	3.4
800	6	6 (10)	6.9	3.7	1.9	0.9	0.7	0.5	0.4	0.2
		10 (8)	10	5.8	3.0	1.5	1.2	0.8	0.6	0.4
		25 (4)	15	11	6.9	3.7	3.0	1.9	1.5	1.0
		50 (0)	17	15	11	6.5	5.4	3.5	2.9	1.8
		70 (00)	17	15	12	7.9	6.7	4.6	3.7	2.4
		120 (250 MCM)	17	16	13	9.8	8.6	6.2	5.2	3.5
1,000	6	6 (10)	7.1	3.7	1.9	0.9	0.7	0.5	0.4	0.2
		10 (8)	11	6.0	3.1	1.5	1.2	0.8	0.6	0.4
		25 (4)	18	12	7.1	3.7	3.0	1.9	1.5	1.0
		50 (0)	21	17	12	6.7	5.5	3.6	2.9	1.8
		70 (00)	21	18	13	8.4	7.0	4.7	3.8	2.4
		120 (250 MCM)	22	19	16	11	9.3	6.5	5.4	3.6

---

## IEC Fuses - With enclosure

### Introduction

#### **DANGER**

##### **HAZARD OF ELECTRIC SHOCK, EXPLOSION, OR FIRE**

The opening of the branch-circuit protective device is able to be an indication that a fault current has been interrupted.

- Current-carrying parts and other components of the controller should be examined and replaced if damaged.
- If burnout of the current element of an overload relay occurs, the complete overload relay must be replaced.

**Failure to follow these instructions will result in death or serious injury.**

### Short Circuit Current Ratings: Selection Table

**Note:**

- Integral solid state short circuit protection in the drive does not provide branch circuit protection. Branch circuit protection must be provided in accordance with any local codes.
- The ATV212 drive has a 100 kA interrupt rating on the output of the drive. In addition to providing a rating based on shorting the output of the drive, these short circuit current ratings have been obtained by shorting components internal to the ATV212. These ratings allow proper coordination of short circuit protection.

**Note:** Verify that the minimum required prospective short-circuit current (Isc) value from the table above is lower than the value estimated in the Calculation section ([see page 24](#)).

**NOTE:** Verify that the minimum Isc value above is lower than the value estimated in the Calculation section ([see page 24](#)).

## 240 Vac Three phase (50/60Hz)

**Note:** Suitable for use on a circuit capable of delivering not more than   X   rms symmetrical kiloAmperes, **240 Vac** Volts maximum, when protected by   Z1   with a maximum rating of   Z2  .

Current limiting fuses can be chosen as SCPD according to the following table:

Drive Catalog Number	gR-gS-aR (Z1, Z2)	Minimum size	SCCR (X)		Minimum Enclosure Volume	
	(A)		Min (A)	Max (kA)	(L)	(in <sup>3</sup> )
ATV212H075M3X	8	10x38	100	5	7,8	476
ATV212HU15M3X	10	10x38	100	5	7,8	476
ATV212HU22M3X	16	10x38	200	5	7,8	476
ATV212HU30M3X	20	10x38	200	5	13,2	805
ATV212HU40M3X	25	10x38	300	5	13,2	805
ATV212HU55M3X	40	14x51	500	22	13,2	805
ATV212HU75M3X	50	14x51	800	22	24	1465
ATV212HD11M3X	63	22x58	1000	22	24	1465
ATV212HD15M3X	100	000	1500	22	53	3223
ATV212HD18M3X	125	00	2000	22	53	3223
ATV212HD22M3X	125	00	2000	22	73	4455
ATV212HD30M3X	160	00	2500	22	197	12039

## 415 Vac Three phase (50/60Hz)

**Note:** Suitable for use on a circuit capable of delivering not more than **X** rms symmetrical kiloAmperes, **415 Vac** Volts maximum, when protected by **Z1** with a maximum rating of **Z2**.

Current limiting fuses can be chosen as SCPD according to the following table:

Drive Catalog Number	gR-gS-aR (Z1, Z2)	Minimum size	SCCR (X)		Minimum Enclosure Volume	
	(A)		Min (A)	Max (kA)	(L)	(in <sup>3</sup> )
ATV212H075N4	4	10x38	100	5	7,8	476
ATV212HU15N4	8	10x38	100	5	7,8	476
ATV212HU22N4	10	10x38	100	5	7,8	476
ATV212HU30N4	12,5	10x38	200	5	13,2	805
ATV212HU40N4	16	10x38	200	5	13,2	805
ATV212HU55N4	20	10x38	200	22	13,2	805
ATV212HU75N4	25	10x38	300	22	24	1465
ATV212HD11N4	40	14x51	500	22	24	1465
ATV212HD15N4	50	000	1000	22	53	3223
ATV212HD18N4	63	000	1000	22	53	3223
ATV212HD22N4	80	000	1500	22	73	4455
ATV212HD30N4	100	000	1500	22	73	4455
ATV212HD37N4	125	00	2000	22	109	6652
ATV212HD45N4	160	00	2500	22	109	6652
ATV212HD55N4	160	00	2500	22	197	12039
ATV212HD75N4	250	1	5000	22	197	12039

---

## IEC Fuses - Wall mounted

### Introduction

#### DANGER

##### HAZARD OF ELECTRIC SHOCK, EXPLOSION, OR FIRE

The opening of the branch-circuit protective device is able to be an indication that a fault current has been interrupted.

- Current-carrying parts and other components of the controller should be examined and replaced if damaged.
- If burnout of the current element of an overload relay occurs, the complete overload relay must be replaced.

**Failure to follow these instructions will result in death or serious injury.**

### Short Circuit Current Ratings: Selection Table

**Note:**

- Integral solid state short circuit protection in the drive does not provide branch circuit protection. Branch circuit protection must be provided in accordance with any local codes.
- The ATV212 drive has a 100 kA interrupt rating on the output of the drive. In addition to providing a rating based on shorting the output of the drive, these short circuit current ratings have been obtained by shorting components internal to the ATV212. These ratings allow proper coordination of short circuit protection.

**Note:** Verify that the minimum required prospective short-circuit current (Isc) value from the table above is lower than the value estimated in the Calculation section ([see page 24](#)).

**NOTE:** Verify that the minimum Isc value above is lower than the value estimated in the Calculation section ([see page 24](#)).

## 240 Vac Three phase (50/60Hz)

**Note:** Suitable for use on a circuit capable of delivering not more than   X   rms symmetrical kiloAmperes, **240 Vac** Volts maximum, when protected by   Z1   with a maximum rating of   Z2  .

Current limiting fuses can be chosen as SCPD according to the following table:

Drive Catalog Number	Wall mounting kit	gR-gS-aR (Z1, Z2)	Minimum size	SCCR (X)	
		(A)		Min (A)	Max (kA)
ATV212H075M3X	VW3A31814	8	10x38	100	5
ATV212HU15M3X	VW3A31814	10	10x38	100	5
ATV212HU22M3X	VW3A31814	16	10x38	200	5
ATV212HU30M3X	VW3A31815	20	10x38	200	5
ATV212HU40M3X	VW3A31815	25	10x38	300	5
ATV212HU55M3X	VW3A31816	40	14x51	500	22
ATV212HU75M3X	VW3A31816	50	14x51	800	22
ATV212HD11M3X	VW3A31817	63	22x58	1000	22
ATV212HD15M3X	VW3A31817	100	000	1500	22
ATV212HD18M3X	VW3A31817	125	00	2000	22
ATV212HD22M3X	VW3A9206	125	00	2000	22
ATV212HD30M3X	VW3A9208	160	00	2500	22

## 415 Vac Three phase (50/60Hz)

**Note:** Suitable for use on a circuit capable of delivering not more than **\_\_X\_\_** rms symmetrical kiloAmperes, **415 Vac** Volts maximum, when protected by **\_\_Z1\_\_** with a maximum rating of **\_\_Z2\_\_**.

Current limiting fuses can be chosen as SCPD according to the following table:

Drive Catalog Number	Wall mounting kit	gR-gS-aR (Z1, Z2)	Minimum size	SCCR (X)	
		(A)		Min (A)	Max (kA)
ATV212H075N4 ATV212W075N4(C)	VW3A31814 -	4	10x38	100	5
ATV212HU15N4 ATV212WU15N4(C)	VW3A31814 -	8	10x38	100	5
ATV212HU22N4 ATV212WU22N4(C)	VW3A31814 -	10	10x38	100	5
ATV212HU30N4 ATV212WU30N4(C)	VW3A31815 -	12,5	10x38	200	5
ATV212HU40N4 ATV212WU40N4(C)	VW3A31815 -	16	10x38	200	5
ATV212HU55N4 ATV212WU55N4(C)	VW3A31815 -	20	10x38	200	22
ATV212HU75N4 ATV212WU75N4(C)	VW3A31816 -	25	10x38	300	22
ATV212HD11N4 ATV212WD11N4(C)	VW3A31816 -	40	14x51	500	22
ATV212HD15N4 ATV212WD15N4(C)	VW3A31817 -	50	000	1000	22
ATV212HD18N4 ATV212WD18N4(C)	VW3A31817 -	63	000	1000	22
ATV212HD22N4 ATV212WD22N4(C)	VW3A9206 -	80	000	1500	22
ATV212HD30N4 ATV212WD30N4(C)	VW3A9206 -	100	000	1500	22
ATV212HD37N4 ATV212WD37N4(C)	VW3A9207 -	125	00	2000	22
ATV212HD45N4 ATV212WD45N4(C)	VW3A9207 -	160	00	2500	22
ATV212HD55N4 ATV212WD55N4(C)	VW3A9208 -	160	00	2500	22
ATV212HD75N4 ATV212WD75N4(C)	VW3A9208 -	250	1	5000	22

## UL Circuit-Breakers and Fuses

### Reference Document

UL Fuse and circuit-breaker information is provided in the ATV212 Quick Start guide Annex ([S1A73476](#)).

### Complementary Information

The following table shows the minimum required prospective short-circuit current (Isc) depending on the drive and **associated circuit-breaker**.

Catalog Number		PowerPact Circuit-breakers	Minimum Isc (A)
200...240 Vac	380...500 Vac		
ATV212U07M3X, ATV212U15M3X	ATV212•075N4(C)	H•L36015	1500
–	ATV212•U15N4(C), ATV212•U22N4(C)	H•L36015	1500
ATV212U22M3X	ATV212•U30N4(C), ATV212•U40N4(C)	H•L36020	1500
–	ATV212•U55N4(C)	H•L36025	1500
ATV212U30M3X	ATV212•U75N4(C)	H•L36030	1500
ATV212U40M3X	–	H•L36035	1700
ATV212U55M3X	ATV212•D11N4(C)	H•L36045	1700
ATV212U75M3X	ATV212•D15N4(C)	H•L36060	3000
–	ATV212•D18N4(C)	H•L36070	3000
ATV212D11M3X	ATV212•D22N4(C)(S)	H•L36090	3000
ATV212D15M3X	ATV212•D30N4(C), ATV212•D37N4(C)	H•L36125	3500
ATV212D18M3X	ATV212•D45N4(C)	H•L36150	3500
ATV212D22M3X	ATV212•D55N4(C)	H•L36175	3500
ATV212D30M3X	ATV212•D75N4(C)	H•L36225	4500

The following table shows the minimum required prospective short-circuit current (Isc) depending on the drive and **associated class J fuse, according to UL248-8**.

Catalog Number		Class J Fuse to UL248-8 (A)	Minimum Isc (A)
200...240 Vac	380...500 Vac		
–	ATV212•075N4(C)	5	300
–	ATV212•U15N4(C)	7.5	500
ATV212U07M3X	ATV212•U22N4(C)	10	500
ATV212U15M3X	ATV212•U30N4(C), ATV212•U40N4(C)	15	500
–	ATV212•U55N4(C)	20	500
ATV212U22M3X	ATV212•U75N4(C)	30	1000
ATV212U30M3X, ATV212U40M3X	–	35	1500
ATV212U55M3X	ATV212•D11N4(C)	45	2000
ATV212U75M3X	ATV212•D15N4(C)	60	2000
–	ATV212•D18N4(C)	80	2000
ATV212D11M3X	ATV212•D22N4(C)	90	2500
ATV212D15M3X	ATV212•D30N4(C)	110	2500
–	ATV212•D37N4(C)	125	3000
ATV212D18M3X	ATV212•D45N4(C)	150	3500
ATV212D22M3X	–	175	5000
ATV212D30M3X	ATV212•D55N4(C)	200	5000
–	ATV212•D75N4(C)	250	6500

---

# Chapter 5

## Technical Data

---

### What's in this Chapter?

This chapter contains the following topics:

Topic	Page
ATV212H dimensions and weights	34
ATV212W dimensions and weights	36
Electrical data	37
Connection diagrams	39

## ATV212H dimensions and weights

The figures below shows outline drawings of the ATV212 drives and the tables gives the dimensions and weights of the various models.

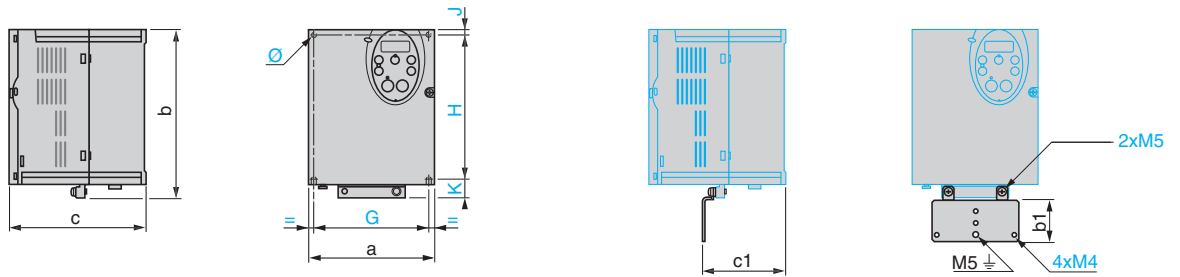

ATV212H	Dimensions mm (in.)										Weight kg (lb)
	a	b	b1	c	c1	G	H	K	J	Ø	
075M3X, U15M3X, U22M3X	107 (4.2)	143 (5.6)	49 (1.93)	150 (5.9)	67.3 (2.65)	93 (3.6)	121.5 (4.7)	16.5 (0.65)	5 (0.20)	5 (0.20)	1.80 (3.978)
075N4, U15N4, U22N4											2.00 (4.42)
U30M3X, U40M3X	142 (5.6)	184 (7.2)	48 (1.8)	150 (5.9)	88.8 (3.50)	126 (4.9)	157 (6.1)	20.5 (0.8)	6.5 (0.26)	5 (0.20)	3.05 (6.741)
U30N4, U40N4, U55N4											3.35 (7.404)

### ATV212HU55M3X, U75M3X, HU75N4, HD11N4

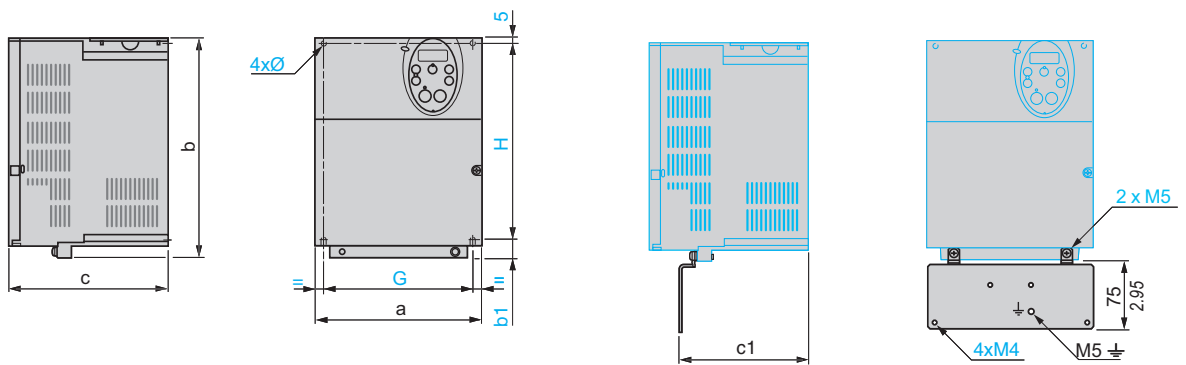

### ATV212HD11M3X, D15M3X, HD15N4, HD18N4, HD22N4S

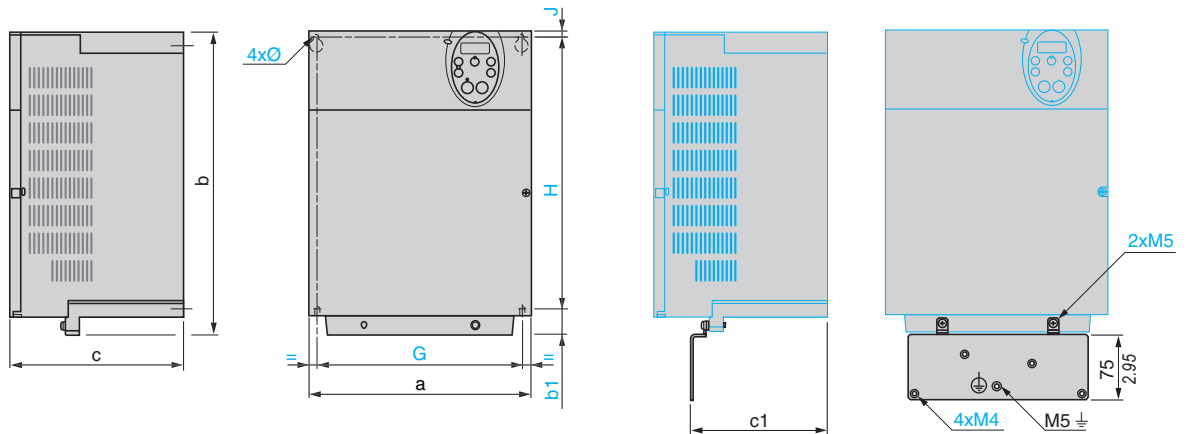

ATV212H	Dimensions mm (in.)										Weight kg (lb)
	a	b	b1	c	c1	G	H	J	Ø		
U55M3X, U75M3X, U75N4, D11N4	180 (7)	232 (9.1)	17 (0.67)	170 (6.7)	134.8 (5.31)	160 (6.3)	210 (8.2)	5 (0.20)	5 (0.20)	6.10 (13.481)	
D11M3X, D15M3X D15N4, D18N4, D18M3X, D22N4S	245 (9.6)	329.5 (12.97)	27.5 (1.08)	190 (7.5)	147.6 (5.81)	225 (8.8)	295 (11.6)	7 (0.28)	6 (0.24)	11.50 (25.4)	

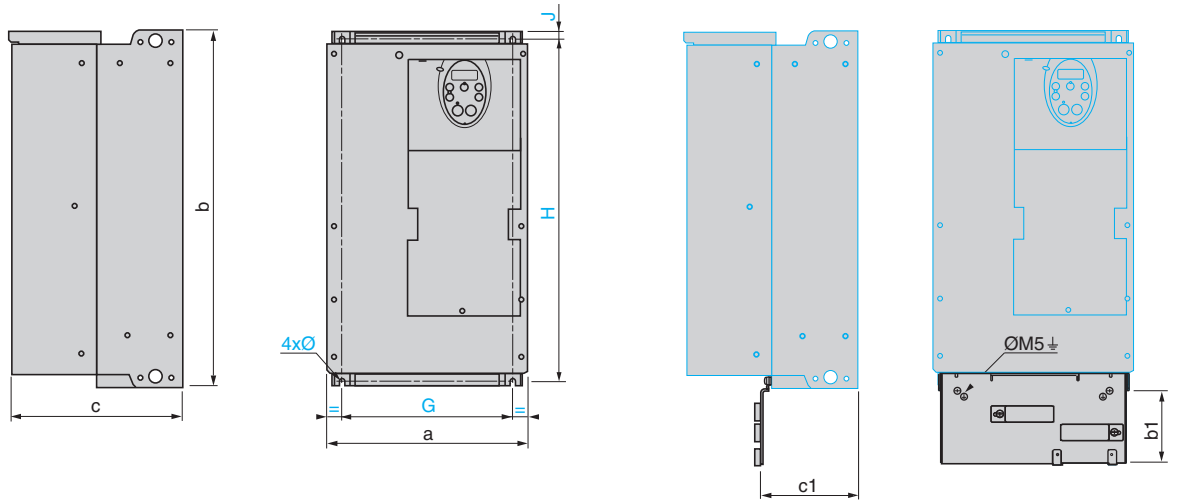

ATV212H	Dimensions mm (in.)									Weight kg (lb)
	a	b	b1	c	c1	G	H	J	Ø	
D22M3X	240 (9.4)	420 (16.5)	122 (4.8)	214 (8.4)	120 (4.72)	206 (8.1)	403 (15.8)	10 (0.39)	6 (0.24)	27.40 (60.554)
D22N4, D30N4										26.40 (58.344)
D37N4, D45N4	240 (9.4)	550 (21.65)	113 (4.45)	244 (9.61)	127 (5.0)	206 (8.1)	529 (20.83)	10 (0.39)	6 (0.24)	23.50 (51.81)

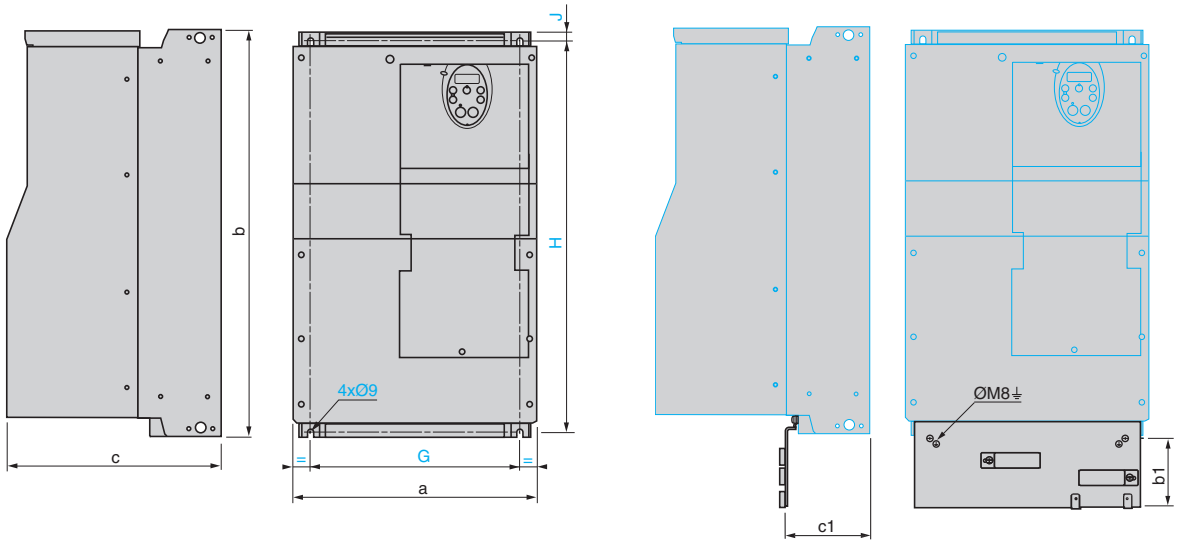

ATV212H	Dimensions mm (in.)									Weight kg (lb)
	a	b	b1	c	c1	G	H	J	Ø	
D30M3X	320 (12.5)	630 (24.8)	118 (4.65)	290 (11.4)	173 (6.81)	280 (11)	604.5 (23.8)	10 (0.39)	9 (0.35)	38.650 (85.42)
D55N4, D75N4	320 (12.5)	630 (24.8)	118 (4.65)	290 (11.4)	173 (6.81)	280 (11)	604.5 (23.8)	10 (0.39)	9 (0.35)	39.70 (87.74)

## ATV212W dimensions and weights

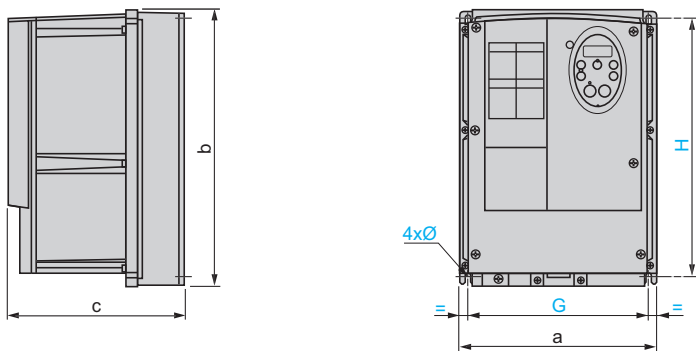

ATV212W	Dimensions mm (in.)						Weight kg (lb)
	a	b	c	G	H	Ø	
075N4...U22N4	215	297	192	197	277	5.5 (0.2)	7.00 (15.43)
075N4C...U22N4C	(8.5)	(11.7)	(7.6)	(7.8)	(10.9)		7.50 (16.53)
U30N4...U55N4	230	340	208	212	318		9.65 (21.27)
U75N4							10.95 (24.14)
U30N4C...U55N4C							10.55 (23.53)
U75N4C							11.85 (26.13)

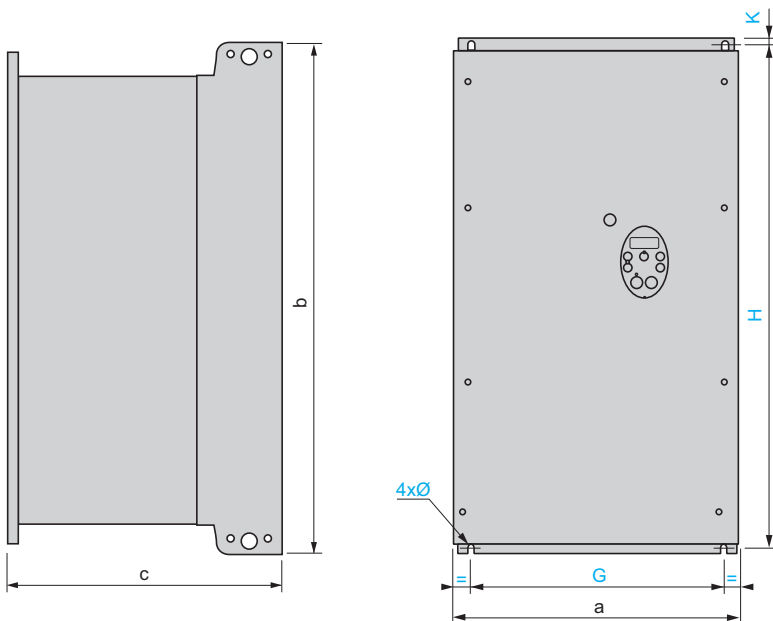

ATV212W	Dimensions mm (in.)							Weight kg (lb)
	a	b	c	G	H	K	Ø	
D11N4, D15N4,	290	560	315	250	544	8	6	30.3 (66.78)
D11N4C, D15N4C	(11.41)	(22.05)	(12.40)	(9.84)	(21.42)	(0.3)	(0.24)	36.5 (80.45)
D18N4,	310	665	315	270	650	10	6	37.4 (82.43)
D18N4C	(12.20)	(26.18)	(12.40)	(10.62)	(25.59)	(0.4)	(0.24)	45 (99.18)
D22N4, D30N4,	284	720	315	245	700	10	7	49.5 (109.10)
D22N4C, D30N4C	(11.18)	(28.35)	(12.40)	(9.64)	(27.56)	(0.4)	(0.27)	58.5 (128.93)
D37N4, D45N4	284	880	343	245	860	10	7	57.4 (126.5)
D37N4C, D45N4C	(11.18)	(34.34)	(13.50)	(9.64)	(33.86)	(0.4)	(0.27)	77.4 (171)
D55N4, D75N4,	362	1000	364	300	975	10	9	61.9 (136.5)
D55N4C, D75N4C	(14.25)	(39.37)	(14.33)	(11.81)	(38.39)	(0.4)	(0.35)	88.4 (195)

## Electrical data

### ATV212H●●●●● - Three-phase supply voltage: 200...240 V 50/60 Hz

Motor		Line supply (input)				Drive (output)			Reference (5)
Power indicated on plate (1)		Max. line current (2)		Apparent power at 240 V	Max. prospective line Isc (3)	Power dissipated at nominal current	Nominal current (1)	Max. transient current (1) (4)	
		at 200 V	at 240 V						
kW	HP	A	A	kVA	kA	W	A	A	
0.75	1	3.3	2.7	1.1	5	63	4.6	5.1	ATV212H075M3X
1.5	2	6.1	5.1	2.1	5	101	7.5	8.3	ATV212HU15M3X
2.2	3	8.7	7.3	3.0	5	120	10.6	11.7	ATV212HU22M3X
3	3	—	10.0	4.2	5	146	13.7	15.1	ATV212HU30M3X
4	5	14.6	13.0	5.4	5	193	18.7	19.3	ATV212HU40M3X
5.5	7.5	20.8	17.3	7.2	22	249	24.2	26.6	ATV212HU55M3X
7.5	10	27.9	23.3	9.7	22	346	32.0	35.2	ATV212HU75M3X
11	15	42.1	34.4	14.3	22	459	46.2	50.8	ATV212HD11M3X
15	20	56.1	45.5	18.9	22	629	61.0	67.1	ATV212HD15M3X
18.5	25	67.3	55.8	23.2	22	698	74.8	82.3	ATV212HD18M3X
22	30	80.4	66.4	27.6	22	763	88.0	96.8	ATV212HD22M3X
30	40	113.3	89.5	37.2	22	1085	117.0	128.7	ATV212HD30M3X

### ATV212H●●●●● - Three-phase supply voltage: 380 ... 480 V 50/60 Hz

Drives with an integrated EMC filter, category C2, C3

Motor		Line supply (input)				Drive (output)			Reference (5)
Power indicated on plate (1)		Max. line current (2)		Apparent power at 380 V	Max. prospective line Isc (3)	Power dissipated at nominal current	Nominal current (1)	Max. transient current (1) (4)	
		at 380 V	at 480 V						
kW	HP	A	A	kVA	kA	W	A	A	
0.75	1	1.7	1.4	1.1	5	55	2.2	2.4	ATV212H075N4
1.5	2	3.2	2.5	2.1	5	78	3.7	4.0	ATV212HU15N4
2.2	3	4.6	3.6	3.0	5	103	5.1	5.6	ATV212HU22N4
3	3	6.2	4.9	4.1	5	137	7.2	7.9	ATV212HU30N4
4	5	8.1	6.4	5.3	5	176	9.1	10.0	ATV212HU40N4
5.5	7.5	10.9	8.6	7.2	22	215	12.0	13.2	ATV212HU55N4
7.5	10	14.7	11.7	9.7	22	291	16.0	17.6	ATV212HU75N4
11	15	21.1	16.8	13.9	22	430	22.5	24.8	ATV212HD11N4
15	20	28.5	22.8	18.7	22	625	30.5	33.6	ATV212HD15N4
18.5	25	34.8	27.8	22.9	22	603	37.0	40.7	ATV212HD18N4
22	30	41.1	32.8	27	22	723	43.5	47.9	ATV212HD22N4S
22	30	41.6	33.1	27.3	22	626	43.5	47.9	ATV212HD22N4
30	40	56.7	44.7	37.3	22	847	58.5	64.4	ATV212HD30N4
37	50	68.9	54.4	45.3	22	976	79	86.9	ATV212HD37N4
45	60	83.8	65.9	55.2	22	1253	94	103.4	ATV212HD45N4
55	75	102.7	89	67.6	22	1455	116	127.6	ATV212HD55N4
75	100	141.8	111.3	93.3	22	1945	160	176	ATV212HD75N4

(1) These values are given for a nominal switching frequency of 12 kHz up to ATV212HD15M3X and up to ATV212HD15N4 or 8 kHz for ATV212HD18M3X...HD30M3X and ATV212HD18N4...HD75N4 drives, 6 kHz for ATV212HD22N4S, for use in continuous operation at 40°C (104 °F) ambient.

The switching frequency can be set between 6 and 16 kHz for all ratings.

Above 8 kHz or 12 kHz, depending on the rating, the drive will reduce the switching frequency automatically in the event of an excessive temperature rise. For continuous operation above the nominal switching frequency, derate the nominal drive current. See page 44 for derating curves as a function of switching frequency, ambient temperature, and mounting conditions.

(2) Current on a line supply with the "Input withstand rating", see QuickStart guide.

(3) Current on a line supply with the indicated short-circuit current rating.

(4) The drive is designed to run up to 60 seconds at this level.

(5) See reference description on page 15.

**ATV212W●●●●● - Three-phase supply voltage: 380 ... 480 V 50/60 Hz**  
**Drives with an integrated EMC filter, category C2, C3**

Motor		Line supply (input)				Drive (output)		Reference (5)
Power indicated on plate (1)		Max. line current (2)		Apparent power	Max. prospective line Isc (3)	Nominal current (1)	Max. transient current (1) (4)	
		at 380 V	at 480 V	at 380 V				
kW	HP	A	A	kVA	kA	A	A	
0.75	1	1.7	1.4	1.1	5	2.2	2.4	ATV212W075N4
1.5	2	3.2	2.5	2.1	5	3.7	4	ATV212WU15N4
2.2	3	4.6	3.6	3	5	5.1	5.6	ATV212WU22N4
3	3	6.2	4.9	4.1	5	7.2	7.9	ATV212WU30N4
4	5	8.1	6.4	5.3	5	9.1	10	ATV212WU40N4
5.5	7.5	10.9	8.6	7.2	22	12	13.2	ATV212WU55N4
7.5	10	14.7	11.7	9.7	22	16	17.6	ATV212WU75N4
11	15	21.2	16.9	14	22	22.5	24.8	ATV212WD11N4
15	20	28.4	22.6	18.7	22	30.5	33.6	ATV212WD15N4
18.5	25	34.9	27.8	23	22	37	40.7	ATV212WD18N4
22	30	41.6	33.1	27.3	22	43.5	47.9	ATV212WD22N4
30	40	56.7	44.7	37.3	22	58.5	64.4	ATV212WD30N4
37	50	68.9	54.4	45.3	22	79	86.9	ATV212WD37N4
45	60	83.8	65.9	55.2	22	94	103.4	ATV212WD45N4
55	75	102.7	89	67.6	22	116	127.6	ATV212WD55N4
75	100	141.8	111.3	93.3	22	160	176	ATV212WD75N4

**ATV212W●●●●● - Three-phase supply voltage: 380 ... 480 V 50/60 Hz**  
**Drives with an integrated C1 EMC filter**

Motor		Line supply (input)				Drive (output)		Reference (5)
Power indicated on plate (1)		Max. line current (2)		Apparent power	Max. prospective line Isc (3)	Nominal current (1)	Max. transient current (1) (4)	
		at 380 V	at 480 V	at 380 V				
kW	HP	A	A	kVA	A	A	A	
0.75	1	1.7	1.4	1.1	5	2.2	2.4	ATV212W075N4C
1.5	2	3.2	2.6	2.1	5	3.7	4	ATV212WU15N4C
2.2	3	4.6	3.7	3	5	5.1	5.6	ATV212WU22N4C
3	3	6.2	5	4.1	5	7.2	7.9	ATV212WU30N4C
4	5	8.2	6.5	5.4	5	9.1	10	ATV212WU40N4C
5.5	7.5	11	8.7	7.2	22	12	13.2	ATV212WU55N4C
7.5	10	14.7	11.7	9.7	22	16	17.6	ATV212WU75N4C
11	15	21.1	16.7	13.9	22	22.5	24.8	ATV212WD11N4C
15	20	28.4	22.8	18.7	22	30.5	33.6	ATV212WD15N4C
18.5	25	34.5	27.6	22.7	22	37	40.7	ATV212WD18N4C
22	30	41.1	33.1	27.1	22	43.5	47.9	ATV212WD22N4C
30	40	58.2	44.4	38.3	22	58.5	64.4	ATV212WD30N4C
37	50	68.9	54.4	45.3	22	79	86.9	ATV212WD37N4C
45	60	83.8	65.9	55.2	22	94	103.4	ATV212WD45N4C
55	75	102.7	89	67.6	22	116	127.6	ATV212WD55N4C
75	100	141.8	111.3	93.3	22	160	176	ATV212WD75N4C

- (1) These values are given for a nominal switching frequency of 12 kHz up to ATV212WD15M3X and up to ATV212HD15N4 or 8 kHz for ATV212WD18M3X...HD30M3X and ATV212WD18N4...HD75N4 drives, for use in continuous operation at 40°C (104 °F) ambient.  
Above 8 kHz or 12 kHz, depending on the rating, the drive will reduce the switching frequency automatically in the event of an excessive temperature rise. For continuous operation above the nominal switching frequency, derate the nominal drive current. See page 44 for derating curves as a function of switching frequency, ambient temperature, and mounting conditions
- (2) Current on a line supply with the "Input withstand rating", see QuickStart guide.
- (3) Current on a line supply with the indicated short-circuit current rating.
- (4) **Note:** The drive is designed to run up to 60 seconds at this level.
- (5) See reference description on page 15.

## Connection diagrams

### Recommended diagram for ATV212H●●●M3X, ATV212●●●●N4, ATV212W●●●N4C

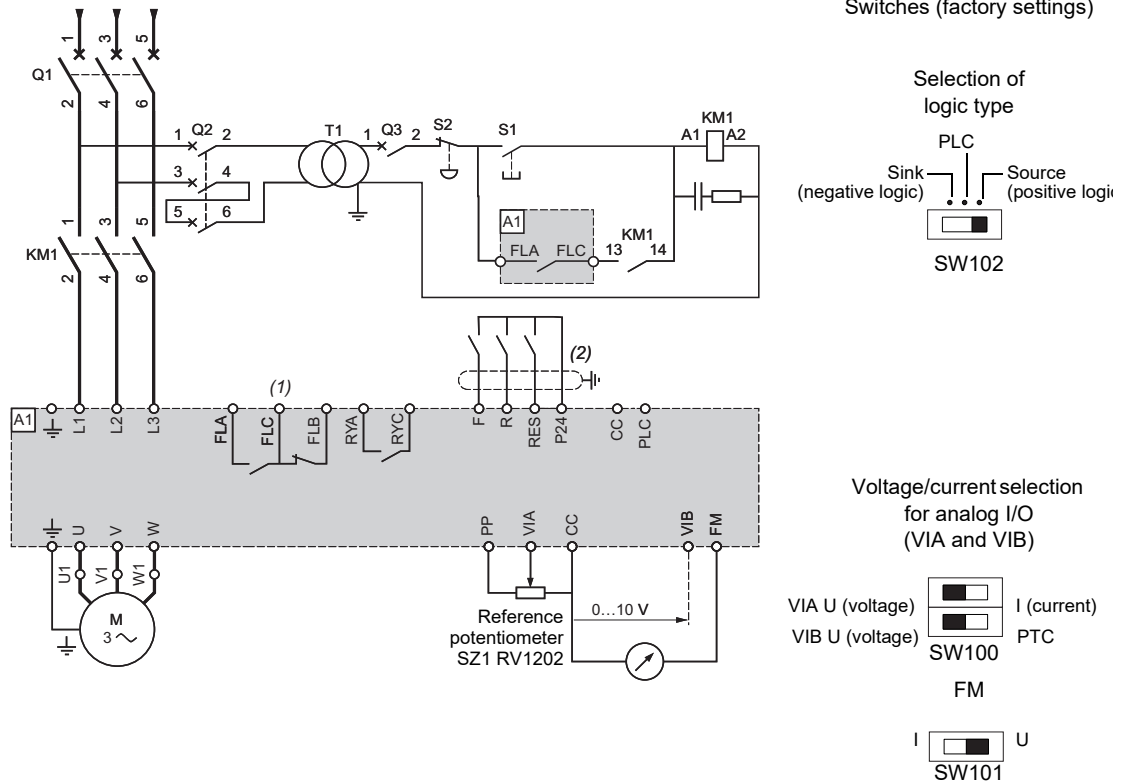

(1) Use relay output R1 set to operating state Fault to switch Off the product once an error is detected.

(2) Connection of the common for the logic inputs depends on the position of the switch (Source, PLC, Sink); see page 62.

## ⚠ DANGER

### UNINTENDED EQUIPMENT OPERATION

- Modify only the setting of switches when the product is switched off.
- Do not change the setting of switch SW102 unless your system is wired for sink logic.

**Failure to follow these instructions will result in death or serious injury.**

## ⚠ CAUTION

### RISK OF BODY INJURY

use a screw driver to change the position of the switches.

**Failure to follow these instructions can result in injury or equipment damage.**

**Note:** All terminals are located at the bottom of the drive. Install interference suppressors on all inductive circuits near the drive or connected on the same circuit, such as relays, contactors, solenoid valves, fluorescent lighting, etc.

## Examples of recommended circuit diagrams

### Logic input switch

The logic input switch SW102 assigns the logic input type to either 24 V (source logic) or 0 V (sink logic).

**⚠ DANGER**

**UNINTENDED EQUIPMENT OPERATION**

- Prevent accidental grounding of logic inputs configured for sink logic. Accidental grounding can result in unintended activation of drive functions.
- Protect the signal conductors against damage that could result in unintentional conductor grounding.
- Follow NFPA 79 and EN 60204 guidelines for proper control circuit grounding practices.

**Failure to follow these instructions will result in death or serious injury.**

### Logic inputs according to the position of the logic type switch

"Source" position

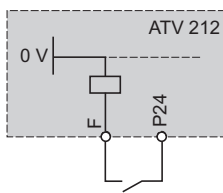

"Sink" position

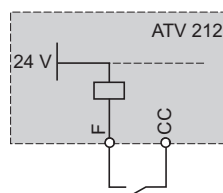

"PLC" position with PLC transistor outputs

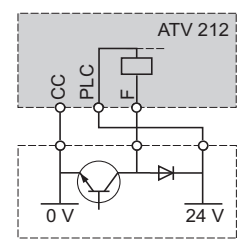
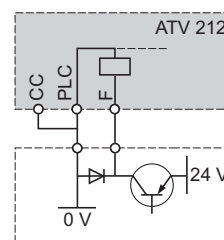

PLC

PLC

2-wire control

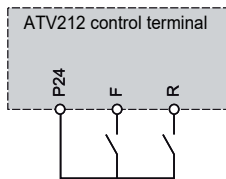

F: Forward  
R: Preset speed

3-wire control

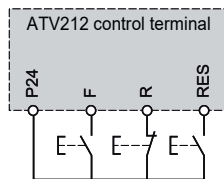

F: Forward  
R: Stop  
RES: Reverse

PTC probe

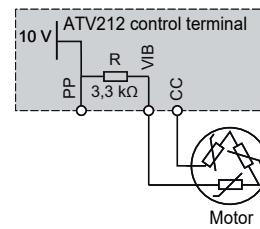

### Analog inputs

Voltage analog inputs  
External + 10 V

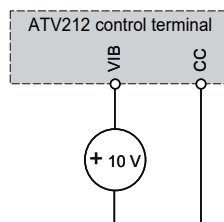
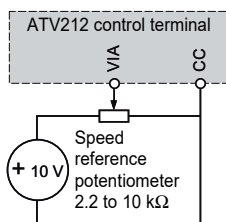

Voltage analog inputs  
0-20 mA, 4-20 mA, X-Y mA

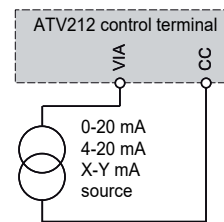

Voltage analog inputs  
Positive logic («Source» position)

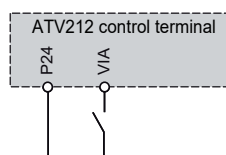

VIA U (voltage)  I (current)

Negative logic («Sink» position)

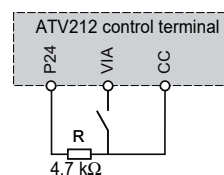

VIA U (voltage)  I (current)

---

# Chapter 6

## Installation

---

### What's in this Chapter?

This chapter contains the following topics:

Topic	Page
Drive mounting generalities	42
Specific recommendations for mounting in an enclosure	51
Position of the charging LED	52
Opening the drive to access terminals	52
Wiring recommendations	55
Power terminals	57
Control terminals and switches	62
Installing option card	65
Use on an impedance grounded (IT) system	66
Electromagnetic compatibility (EMC)	69
Checking the Installation	73

## Drive mounting generalities

### **⚡ ⚠ DANGER**

#### **HAZARD OF FIRE OR ELECTRIC SHOCK**

The open type product does not provide comprehensive mitigation for fire hazards and protection against direct contact to hazardous live parts.

- Install the product inside a supplementary enclosure which provides appropriate protection against spread of fire and electric shock.

**Failure to follow these instructions will result in death or serious injury.**

### **⚠ DANGER**

#### **RISK OF FIRE**

The device is suitable for mounting on concrete or other non-combustible surfaces only.

**Failure to follow these instructions will result in death or serious injury.**

### **NOTICE**

#### **RISK OF DAMAGE TO THE DRIVE**

Follow mounting recommendations described in this document.

**Failure to follow these instructions can result in equipment damage.**

## Attaching A Label With Safety Instructions

A label kit is provided with the drive.

Step	Action
1	Observe the safety regulations in the target country
2	Select the label suitable for the target country
3	<p>Attach the label to the front of the device so that it is clearly visible. Below is the English version. The label can vary depending on the frame size of the product.</p> <div data-bbox="446 1335 655 1626" data-label="Image"> </div> <p><b>NOTE: Products used in Canada</b> according to CSA C22.2 no.274 must comply with the requirement defined by the Canadian Advisory council of Electrical Safety (CACES). It defines that dual language (French and English) safety labeling is required on all products for use in Canada. To fulfill this requirement, add the French language safety label on the front panel of the product.</p>

## Mounting and temperature conditions

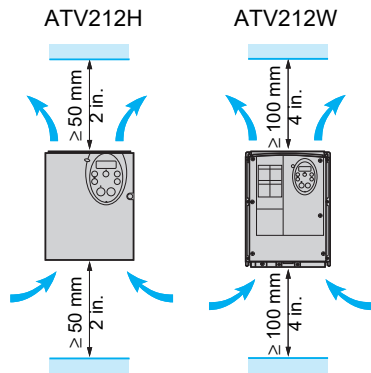

Depending on the conditions in which the drive is to be used, its installation will require certain precautions and the use of appropriate accessories.

- Install the drive vertically, at  $\pm 10^\circ$ .
- Fix it on the mounting surface using M5 screws with captive washer.
- Do not place it close to heating elements.
- Leave sufficient free space so that the air required for cooling purposes can circulate from the bottom to the top of the drive.
- Free space in front of the drive: 10 mm (0.39 in.) minimum.

The use of washers is recommended with all mounting screws.

## Mounting methods

### Type A mounting - ATV212H●●●M3X, ATV212H●●●N4● and ATV212W●●●N4, ATV212W●●●N4C

Free space  $\geq 50$  mm (2 in.) on each side, with the protective cover in place.

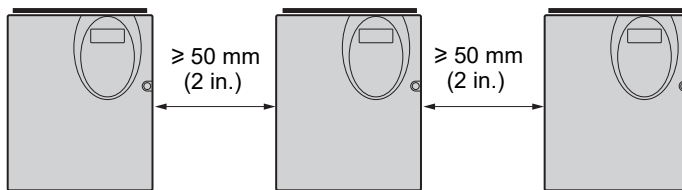

### Type B mounting - ATV212H●●●M3X, ATV212H●●●N4●

Drives mounted side-by-side, with the protective cover removed (degree of protection becomes open type IP20).

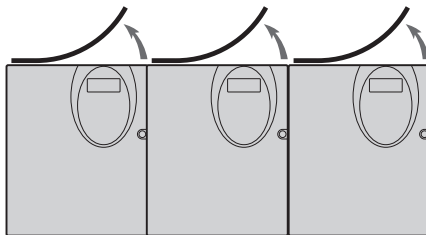

### Type C mounting - ATV212H●●●M3X, ATV212H●●●N4●

Free space  $\geq 50$  mm (2 in.) on each side, with the protective cover removed (degree of protection becomes open type IP20).

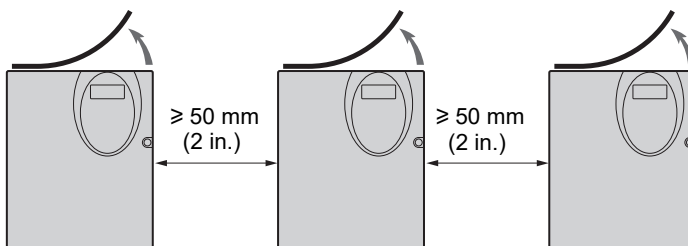

These mounting types are possible without derating up to 40°C (104 °F) at the factory-set switching frequency. For other ambient temperatures and switching frequencies, see derating curves page 44.

## Removing the protective cover on ATV212H drives

See Mounting methods, page 43 to determine the type of mounting appropriate for your application before removing the protective cover from the drive.

When IP20 protection is adequate, remove the protective cover on top of the drive as shown below.

For UL Type 1 protection, leave the protective cover on top of the drive and install a conduit entry kit (mounting outside the enclosure). See entry kit references in the catalog on [www.se.com](http://www.se.com).

**ATV212H 075M3X to D18M3X, and  
ATV212H 075N4 to D22N4S**

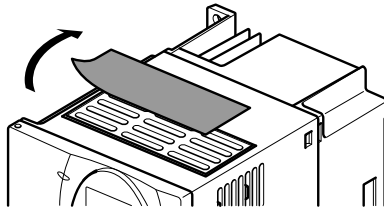

**ATV212H D22M3X to D30M3X and  
ATV212H D22N4 to D30N4**

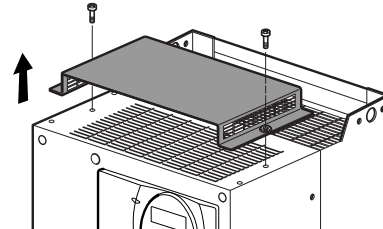

## Derating curves

The curves illustrate the drive nominal current derating percentage ( $I/I_n\%$ ) as a function of the temperature, switching frequency, and the different types of mounting (A, B and C).

For example, 80% derating of a 20 hp, 460 V ATV212 drive nominally rated for 30.5 amperes continuously:  $30.5 \times 0.8 = 24.4$  (15 hp).

For intermediate temperatures, interpolate between two curves.

**ATV212H075M3X**

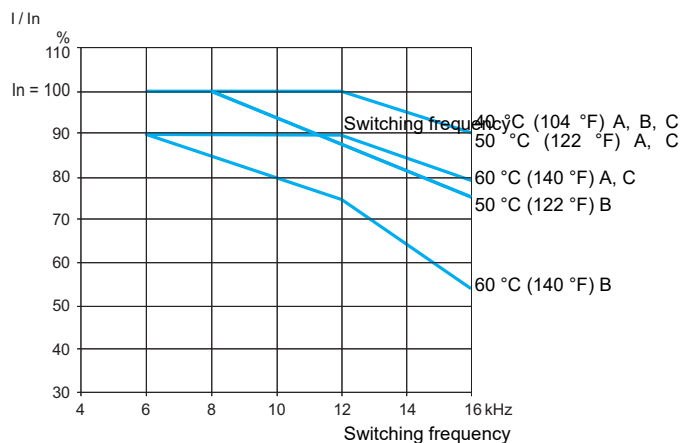

**ATV212HU15M3X**

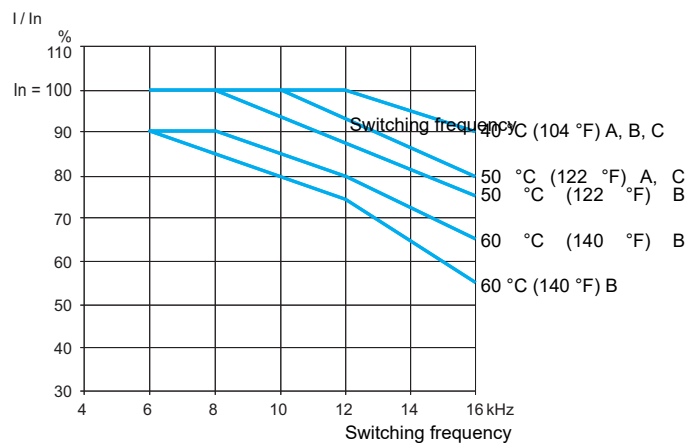

**ATV212HU22M3X**

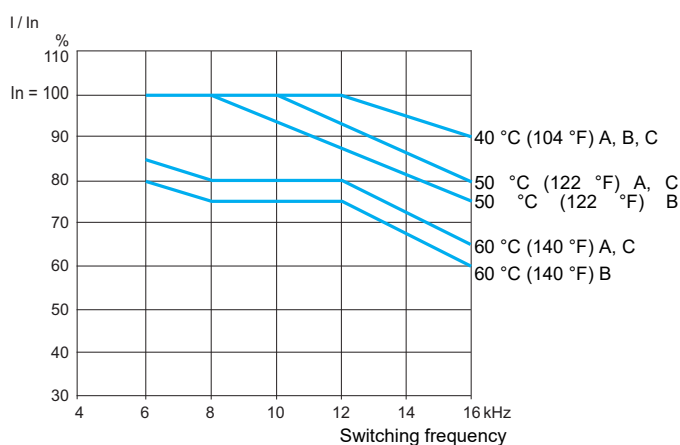

**ATV212HU30M3X, HU40M3X**

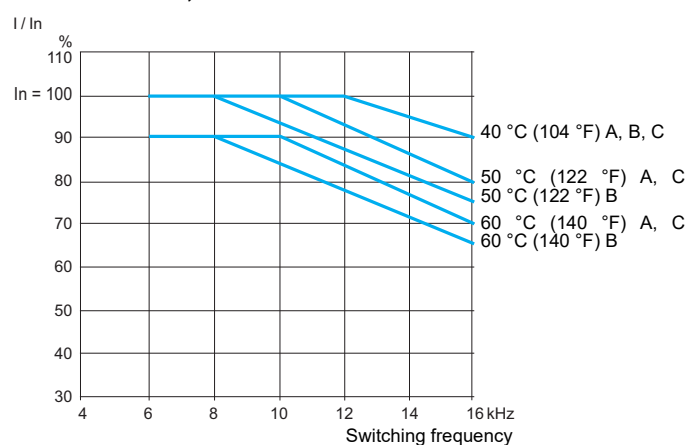

**ATV212HU55M3X**

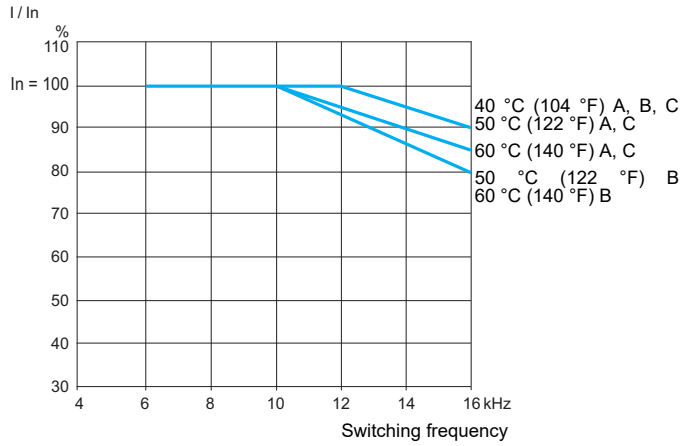

**ATV212HU75M3X**

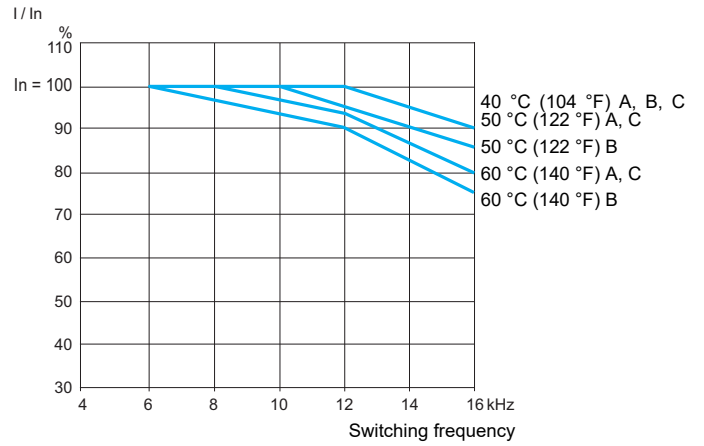

**ATV212HD11M3X**

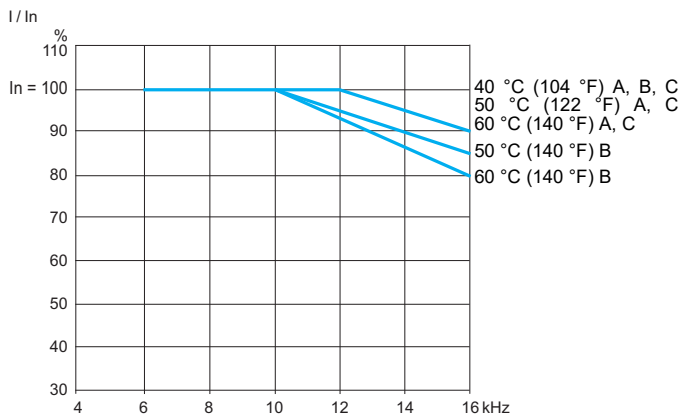

**ATV212HD15M3X**

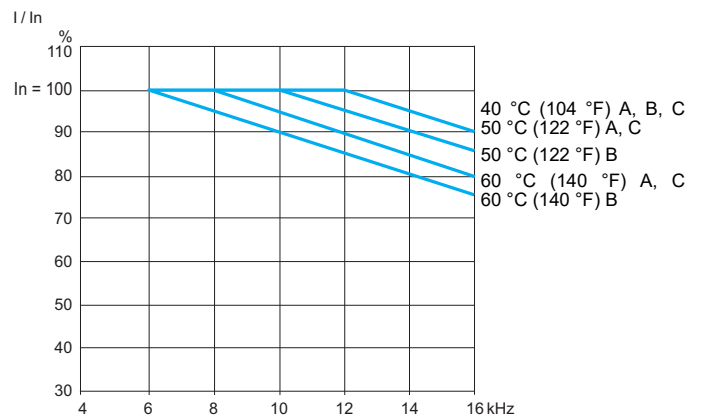

**ATV212HD18M3X**

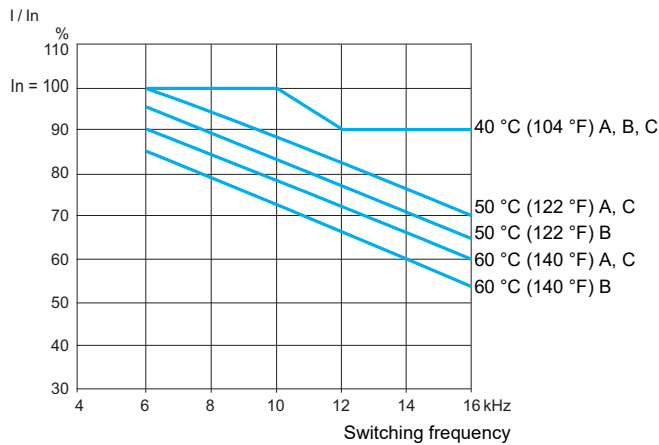

**ATV212HD22M3X**

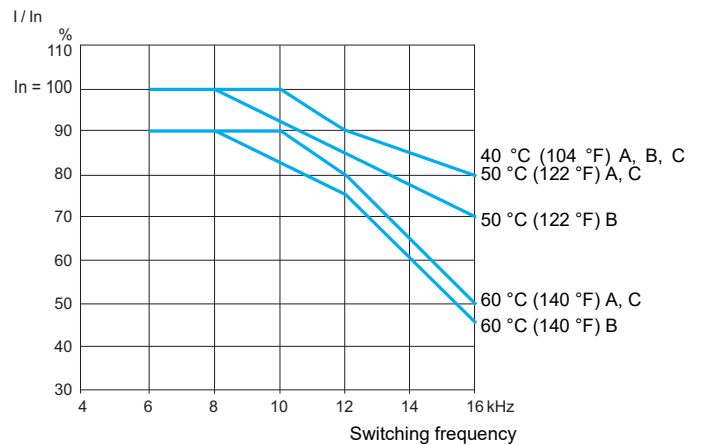

**ATV212HD30M3X**

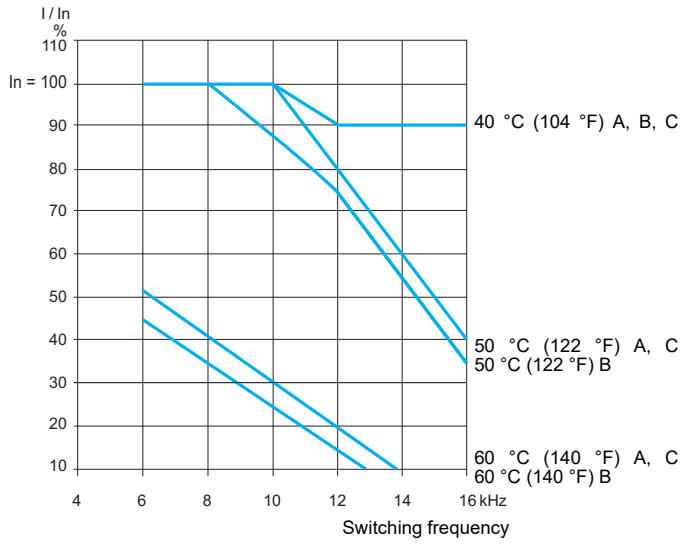

**ATV212H075N4**

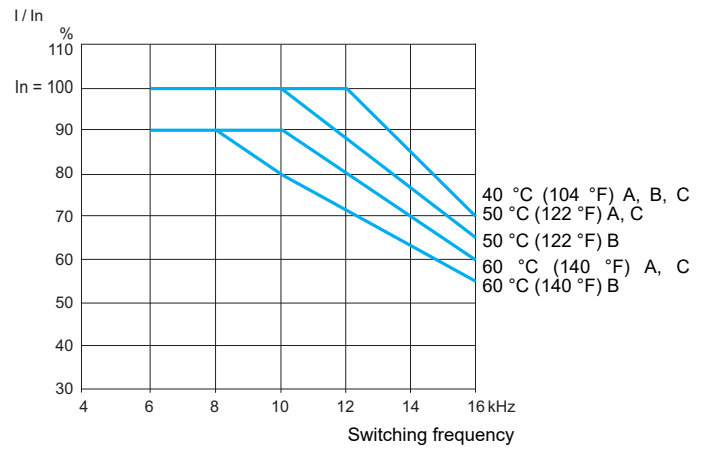

**ATV212HU15N4**

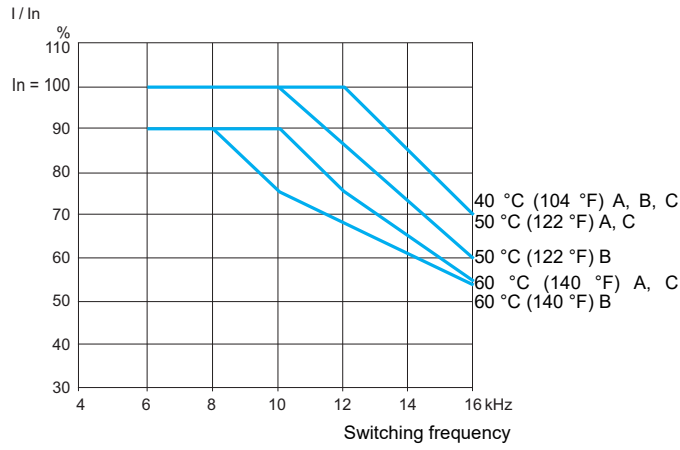

**ATV212HU22N4**

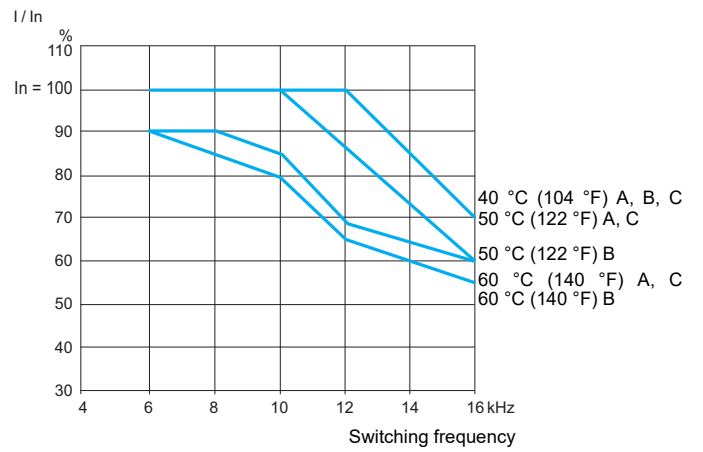

**ATV212HU30N4, HU40N4**

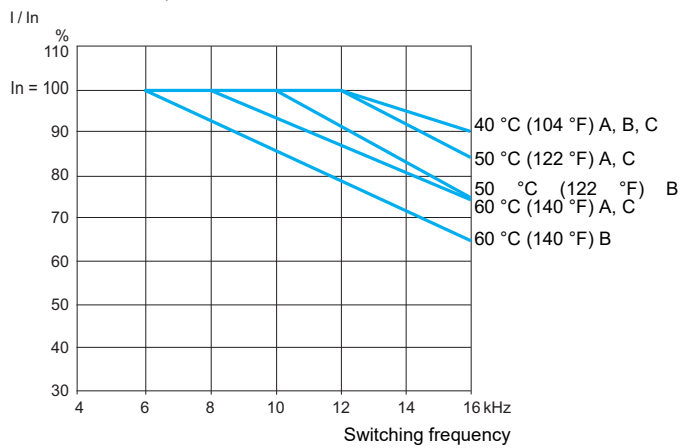

**ATV212HU55N4**

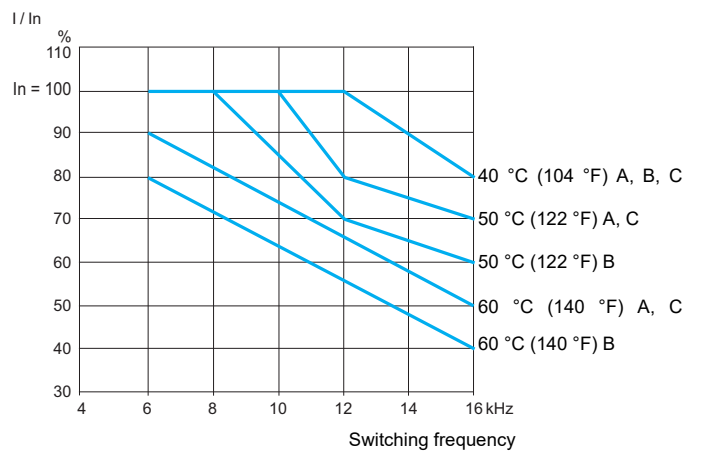

**ATV212HU75N4**

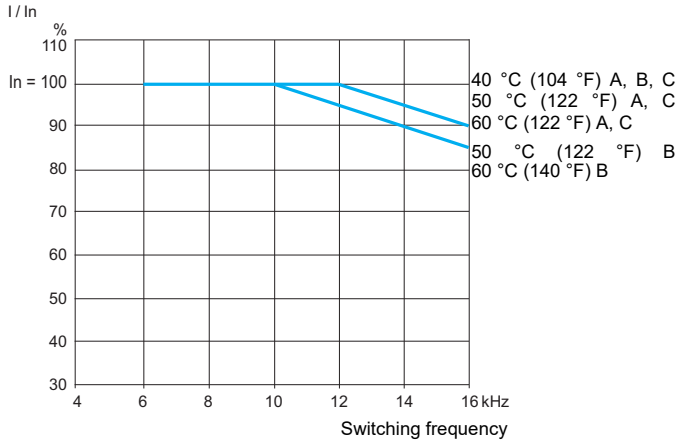

**ATV212HD11N4**

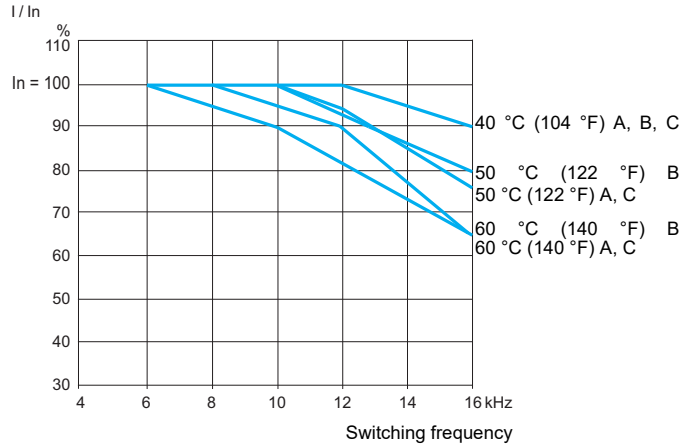

**ATV212HD15N4**

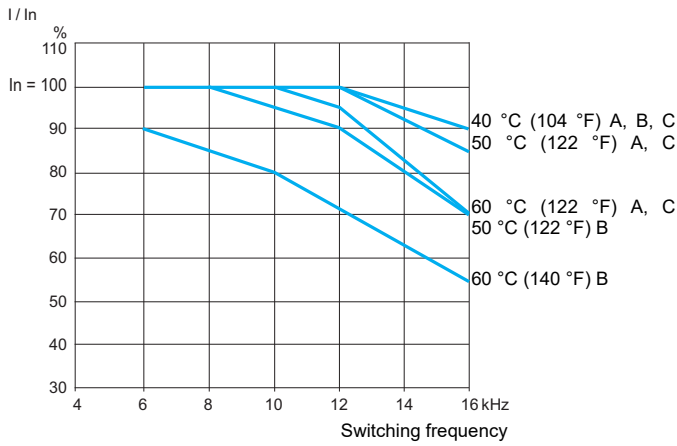

**ATV212HD18N4**

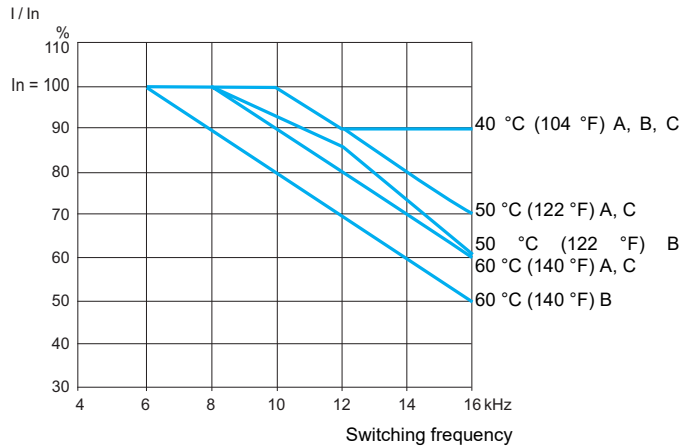

**ATV212HD22N4**

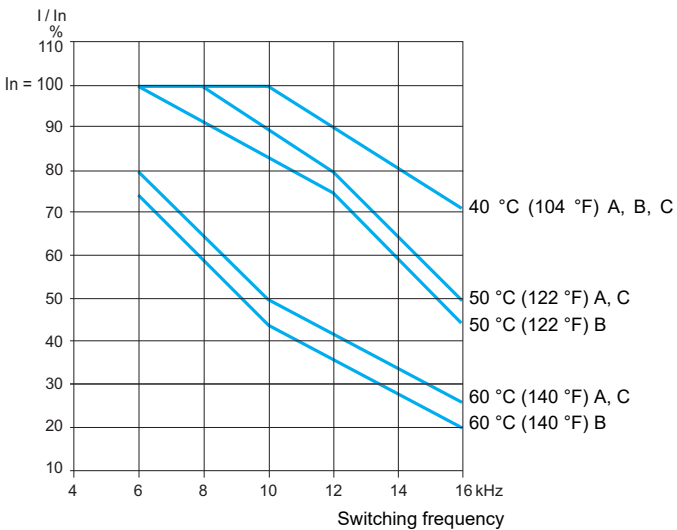

**ATV212HD22N4S**

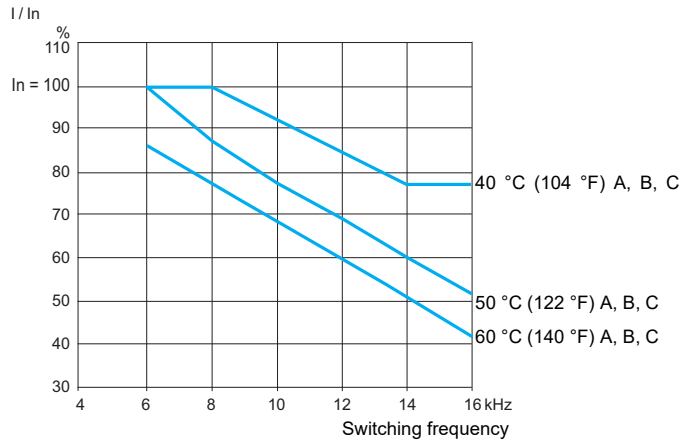

**ATV212HD30N4**

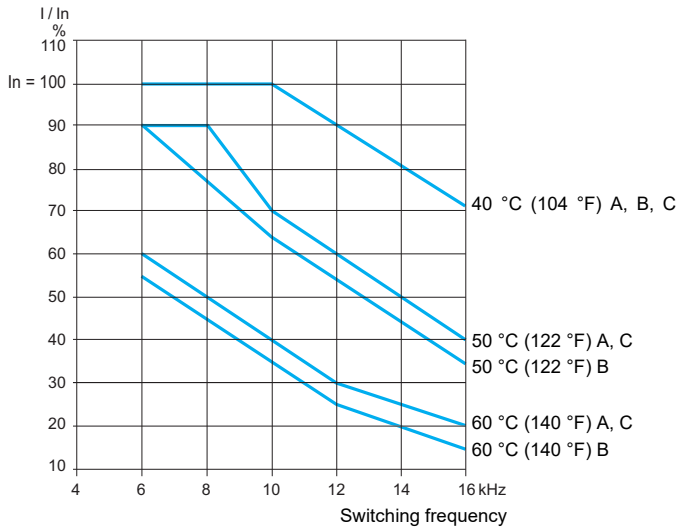

**ATV212HD37N4**

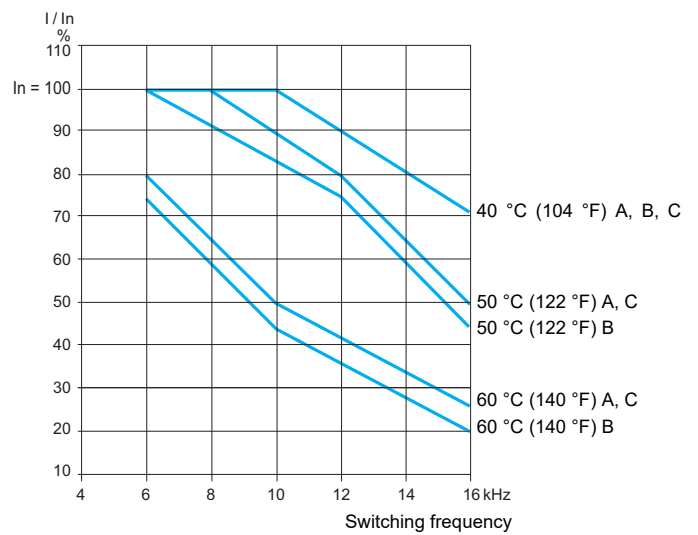

**ATV212HD45N4**

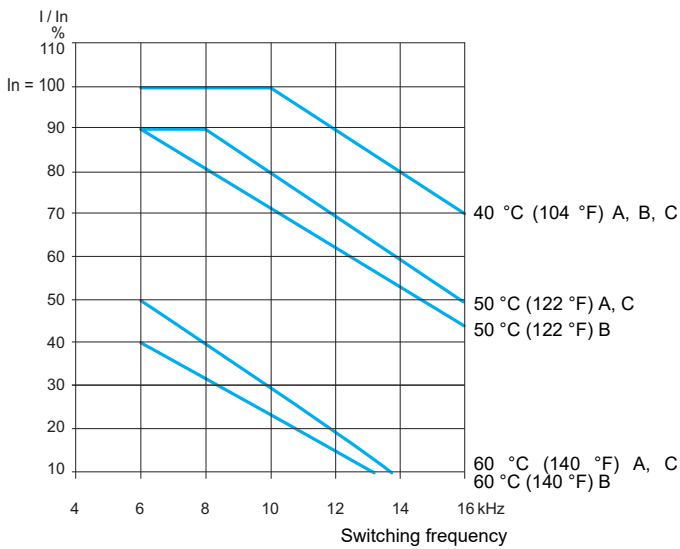

**ATV212HD55N4**

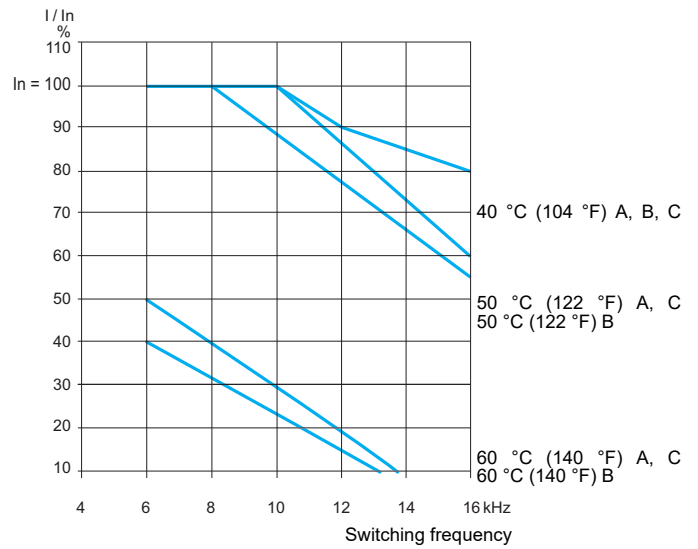

**ATV212HD75N4**

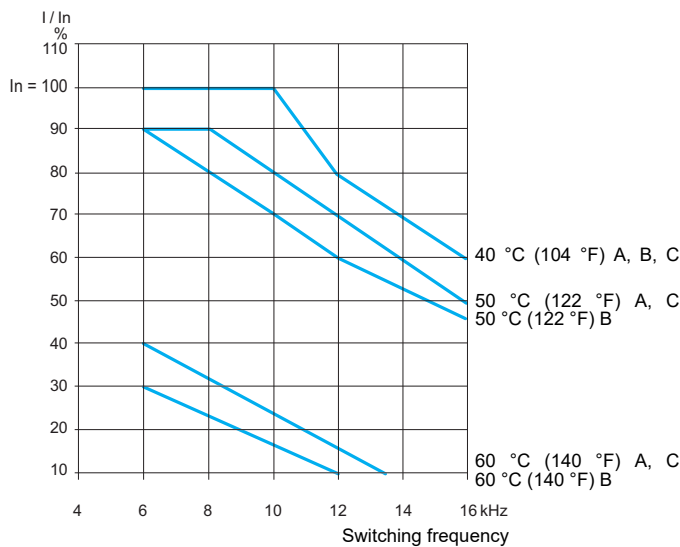

**ATV212W075N4...WU75N4, ATV212W075N4C...WU75N4C**

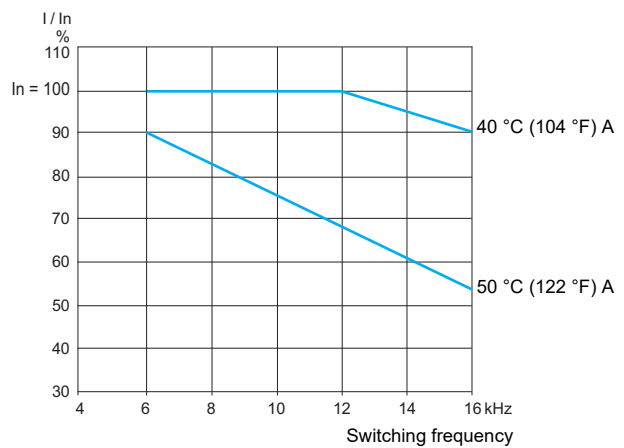

**ATV212WD11N4, ATV212WD11N4C**

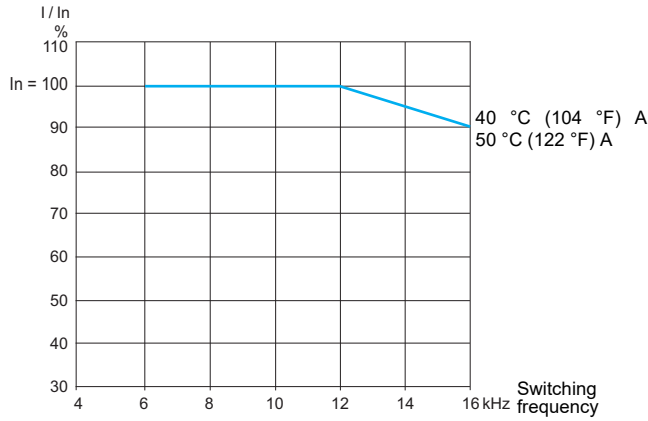

**ATV212WD15N4, ATV212WD15N4C**

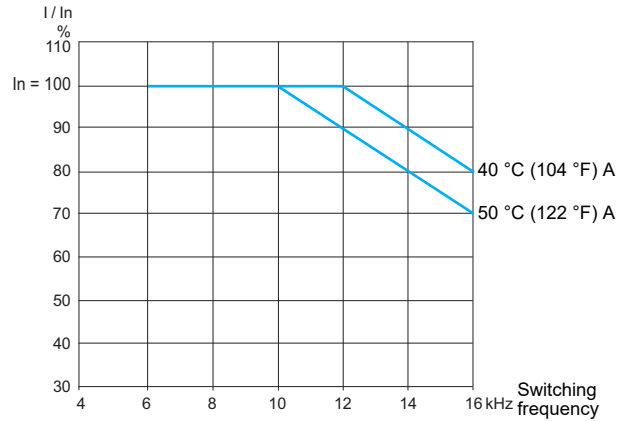

**ATV212WD18N4, ATV212WD18N4C**

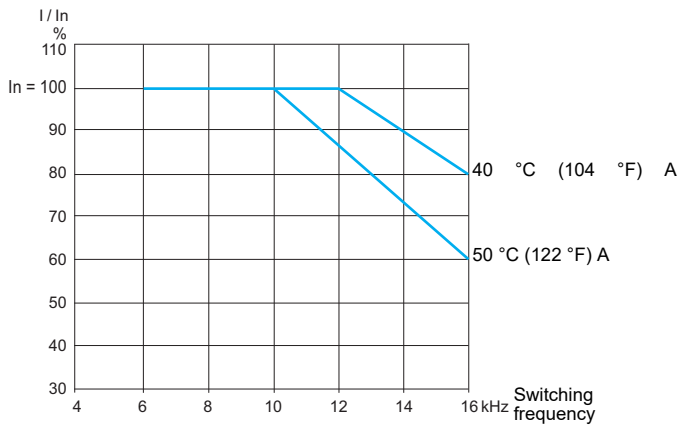

**ATV212WD22N4, ATV212WD22N4C**

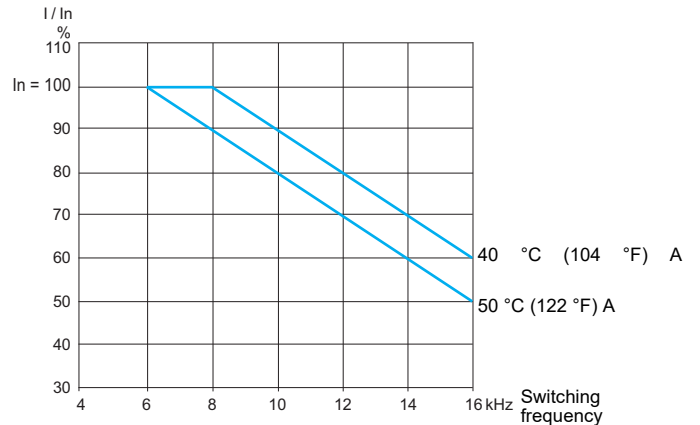

**ATV212WD30N4, ATV212WD30N4C**

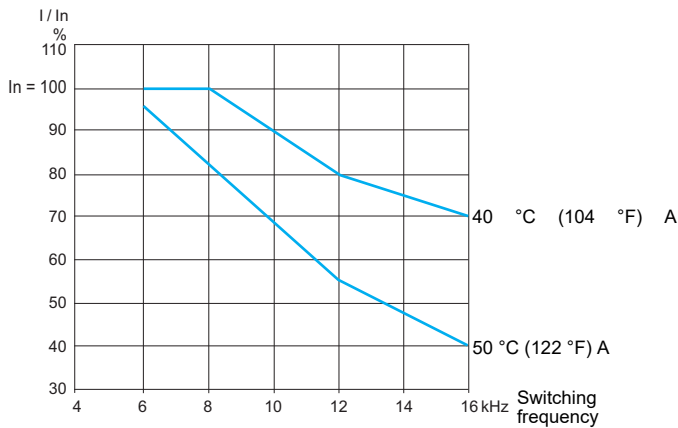

**ATV212WD37N4, ATV212WD37N4C**

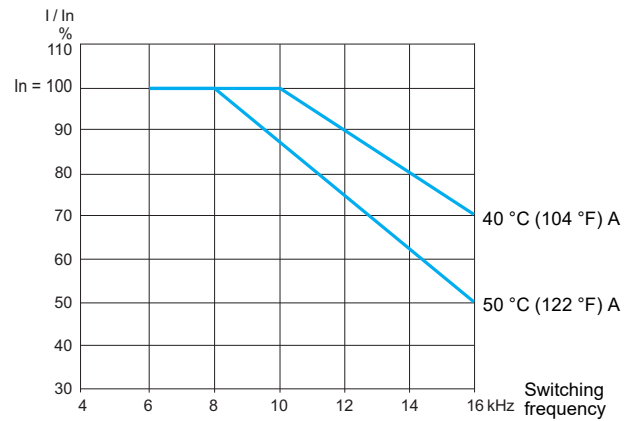

**ATV212WD45N4, ATV212WD45N4C**

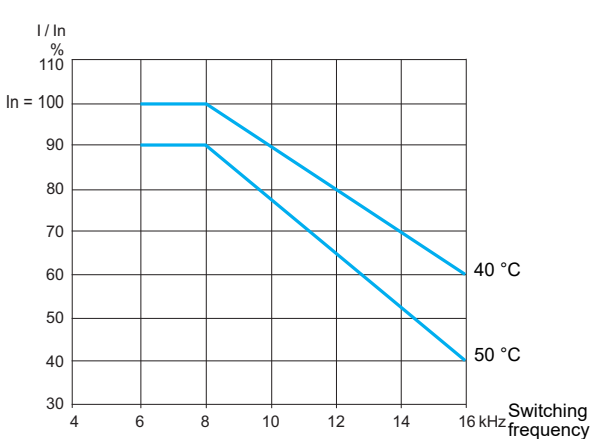

**ATV212WD55N4, ATV212WD55N4C**

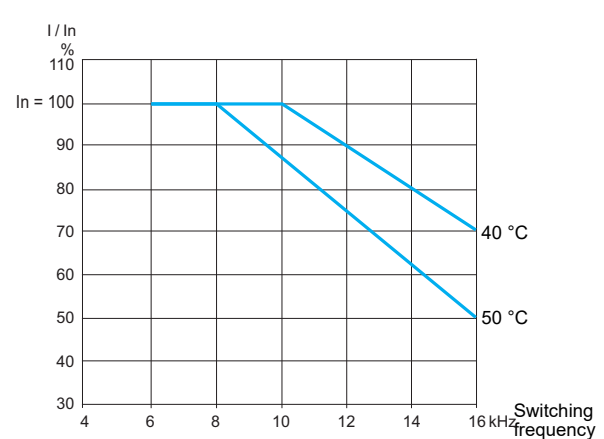

**ATV212WD75N4, ATV212WD75N4C**

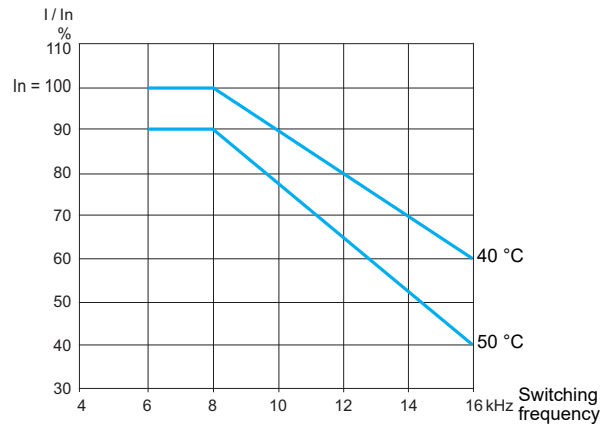

## Specific recommendations for mounting in an enclosure

**Note:** The following only applies to ATV212H●●●M3X and ATV212H●●●N4 drives.

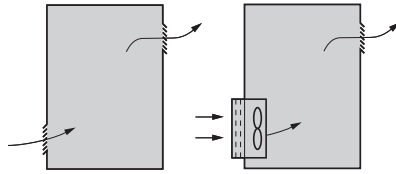

Observe the mounting recommendations described on page 42.

To help ensure proper air circulation in the drive:

- Fit ventilation grilles.
- Check that there is sufficient ventilation. If there is not, install a forced ventilation unit with a filter. The openings and/or fans must provide a flow rate at least equal to that of the drive fans (see below).
- Use special filters with UL Type 12/IP54 protection.
- Remove the blanking cover from the top of the drive, see page 43.

## Minimum air flow rates

If you are installing the drive in a Type 1 enclosure, provide forced ventilation at a rate at least equal to the value listed below each drive.

For drive	Flow rate	
	m <sup>3</sup> /hour	ft <sup>3</sup> /min
ATV212H075M3X	22	13
ATV212HU15M3X	35	21
ATV212HU22M3X	41	25
ATV212HU30M3X	50	30
ATV212HU40M3X	66	39
ATV212HU55M3X	85	50
ATV212HU75M3X	118	70
ATV212HD11M3X	157	93
ATV212HD15M3X	215	127
ATV212HD18M3X	239	141
ATV212HD22M3X	261	154
ATV212HD30M3X	371	219

For drive	Flow rate	
	m <sup>3</sup> /hour	ft <sup>3</sup> /min
ATV212H075N4	19	12
ATV212HU15N4	27	16
ATV212HU22N4	35	21
ATV212HU30N4	47	28
ATV212HU40N4	60	36
ATV212HU55N4	74	44
ATV212HU75N4	100	59
ATV212HD11N4	147	87
ATV212HD15N4	206	122
ATV212HD18N4	214	126
ATV212HD22N4S	214	126
ATV212HD22N4	214	126
ATV212HD30N4	290	171
ATV212HD37N4	334	197
ATV212HD45N4	429	252
ATV212HD55N4	498	293
ATV212HD75N4	666	392

## Sealed metal enclosure

### NOTICE

#### RISK DUE TO CONDENSATION

Where condensation is possible, keep the drive powered up when the motor is not running, or install thermostatically controlled strip heaters.

**Failure to follow these instructions can result in equipment damage.**

The drive must be mounted in a dust and damp proof enclosure in certain environmental conditions, such as dust, corrosive gases, high humidity with risk of condensation and dripping water, splashing liquid, etc.

This enables the drive to be used in an enclosure where the maximum internal temperature reaches 50°C.

When mounting the drive inside an UL Type 12 or IP54 enclosure, follow these ventilation instructions:

- Observe the minimum clearance distances shown on page 43.
- If necessary, install a stirring fan to circulate the air inside the enclosure, to help prevent hot spots in the drive, and to distribute the heat uniformly to surfaces used for convection cooling.

## Position of the charging LED

The capacitor charging LED on the drive is not an indicator of the absence of DC bus voltage. It only indicates when the capacitor is fully charged.

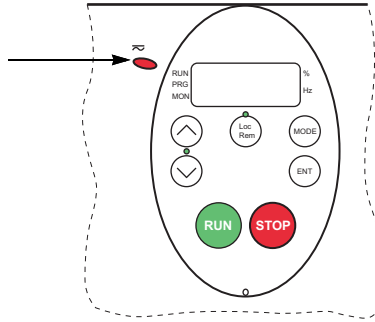

## Opening the drive to access terminals

### Procedure

- 1 Any procedure in this section must be performed when product is powered off.

### **⚠ ⚠ DANGER**

#### **HAZARD OF ELECTRIC SHOCK, EXPLOSION OR ARC FLASH**

Read and understand the instructions in "before you begin" chapter, before performing the procedure in this section.

**Failure to follow these instructions will result in death or serious injury.**

- 2 Open the ATV212 front cover.

#### **ATV212H products up to 22 kW**

Turn the screw on the front panel 90° counter-clockwise to align the dot on the screw with the unlock position.

To avoid damaging the screw, do not apply excessive force or turn the screw more than 90°.

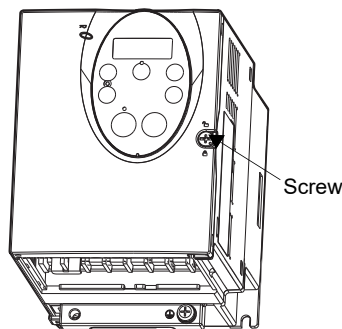

Pull the front panel toward you and swing it open to the left

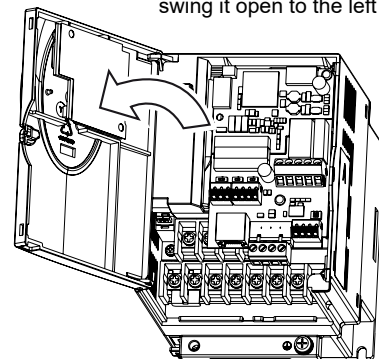

#### **ATV212H products from 22 kW**

Remove the screws.  
Lift off the cover.

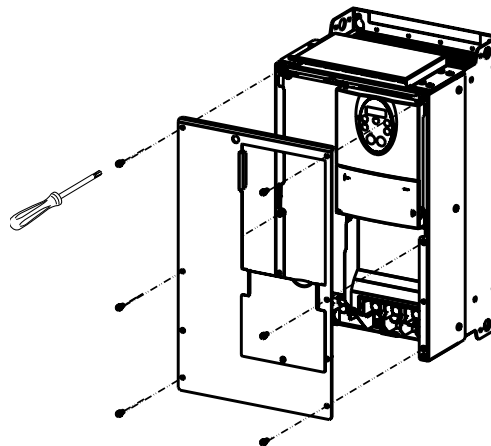

ATV212W up to 7.5 kW

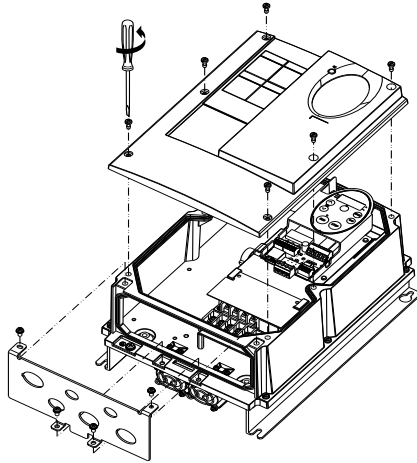

ATV212W above 7.5 kW

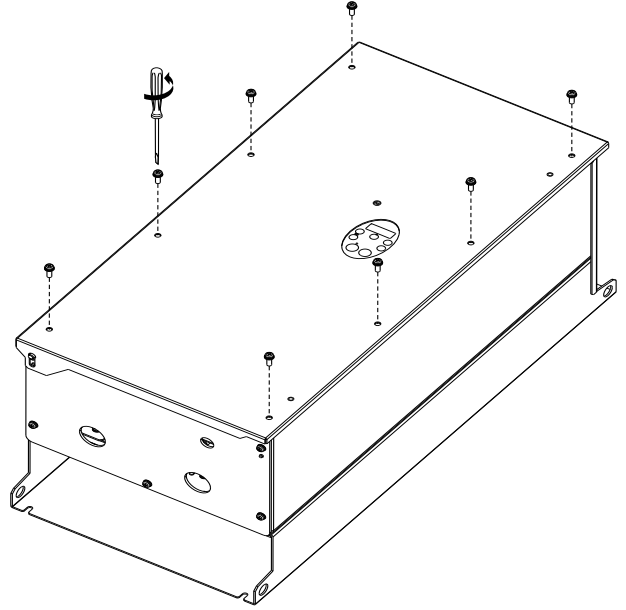

### Terminal location on ATV212H

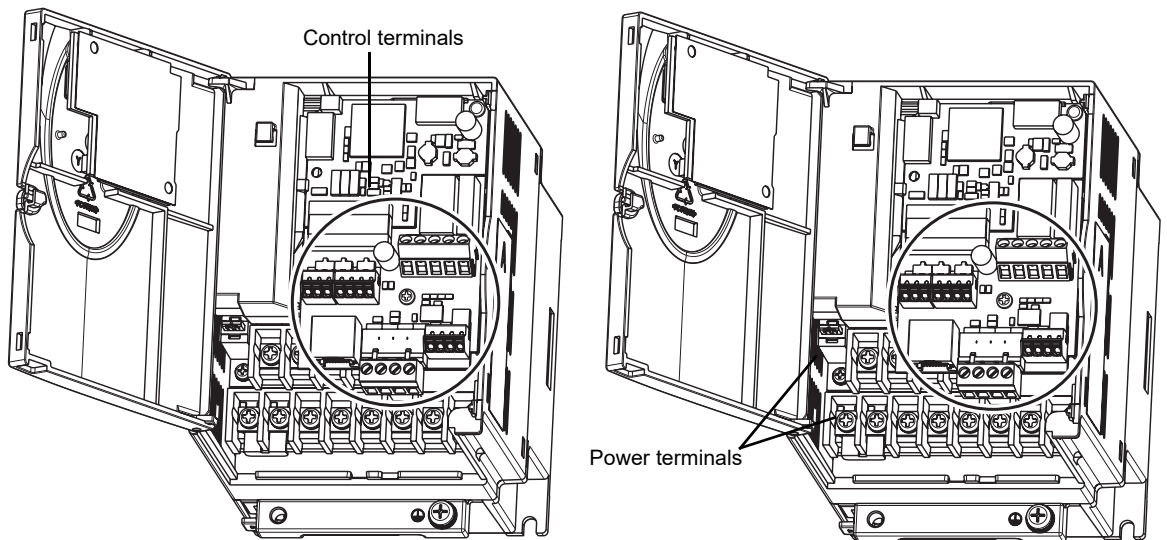

On drives ATV212H075M3X...U22N4 (page 14) first remove control board to access power terminals.

- 1 Remove the terminal board mounting screw and take off the ATV212 standard terminal board. Be careful not to lose the terminal board mounting screw.
- 2 Connect the power terminals
- 3 Reinstall the terminal board and fit the board mounting screw (M3 tapping type) and tighten to 0.7 to 0.8Nm.

## Terminal location on ATV212W

Example ATV212WU55N4C

Example ATV212WD15N4

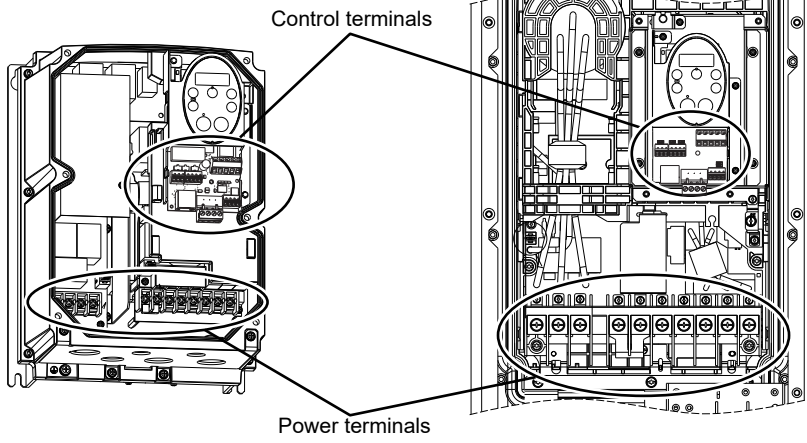

Example ATV212WD18N4C

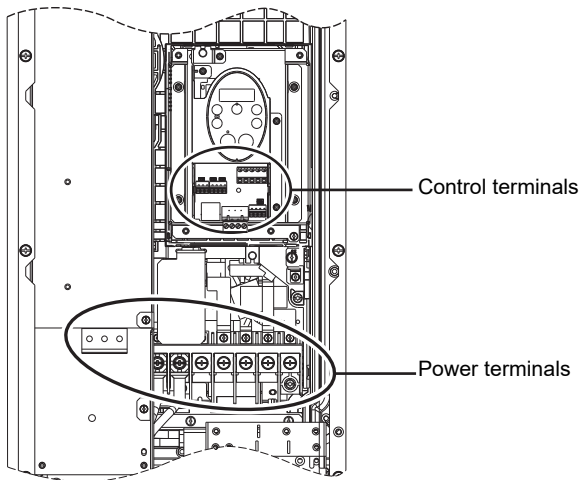

## Wiring recommendations

### **DANGER**

#### **HAZARD OF ELECTRIC SHOCK, EXPLOSION OR ARC FLASH**

- To avoid overheating or loss of contact, connections must be carried out according to the cable sizes and tightening torques given in this document.
- The use of multi-wire cable without a lug is forbidden for the mains connection.
- Carry-out a pull out test to check that terminal screws are correctly tighten.

**Failure to follow these instructions will result in death or serious injury.**

#### **Power and circuit protection**

The drive must be grounded to conform with the regulations concerning high leakage currents (over 3.5 mA).

Where local and national codes require upstream protection by means of a residual current device, use a type A device for single-phase drives and a type B device for three-phase drives as defined in the IEC Standard 60755.

Choose a suitable model integrating:

- High frequency current filtering,
- A time delay that helps to prevent tripping caused by the load from stray capacitance on power-up.  
The time delay is not possible for 30 mA devices; in this case, choose devices with immunity against nuisance tripping.

If the installation includes several drives, provide one "residual current device" per drive.

Keep the power cables separate from circuits in the installation with low-level signals (detectors, PLCs, measuring apparatus, video, telephone).

If you are using cables longer than 50 m (164 ft) between the drive and the motor, add output filters (for more details please refer to the catalog).

#### **Control**

Keep the control circuits away from the power cables. For control and speed reference circuits, we recommend using shielded twisted cables with a pitch of between 25 and 50 mm (1 and 2 in.), connecting the shielding to ground at each end.

## Equipment Grounding

Ground the drive according to local and national code requirements. A minimum wire size of 10 mm<sup>2</sup> (6 AWG) may be required to meet standards limiting leakage current.

### ⚠️ DANGER

#### HAZARD OF ELECTRIC SHOCK, EXPLOSION OR ARC FLASH

- The drive panel must be properly grounded before power is applied.
- Use the provided ground connecting point as shown in the figure.

**Failure to follow these instructions will result in death or serious injury.**

### ⚠️ WARNING

#### INADEQUATE OVERCURRENT PROTECTION

- Overcurrent protective devices must be properly coordinated.
- The Canadian Electrical Code and the National Electrical Code require branch circuit protection. Use the recommendations in the ATV212 Quick Start Annex document, reference S1A73476 provided with the product.
- Do not connect the drive to a power feeder whose short-circuit capacity exceeds the maximum prospective line Isc listed in this manual.

**Failure to follow these instructions can result in death, serious injury, or equipment damage.**

### NOTICE

#### RISK OF DAMAGE TO THE DRIVE

- The drive will be damaged if input line voltage is applied to the output terminals (U/T1,V/T2,W/T3).
- Check the power connections before energizing the drive.
- If replacing the existing drive by another drive, verify that all wiring connections to the drive comply with wiring instructions in this manual

**Failure to follow these instructions can result in equipment damage.**

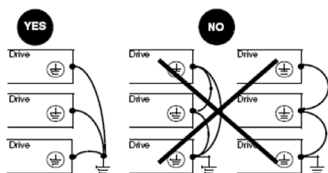

- Ensure that the resistance of the ground is one ohm or less.
- When grounding several drives, you must connect each one directly, as shown in the figure to the left.
- Do not loop the ground cables or connect them in series.



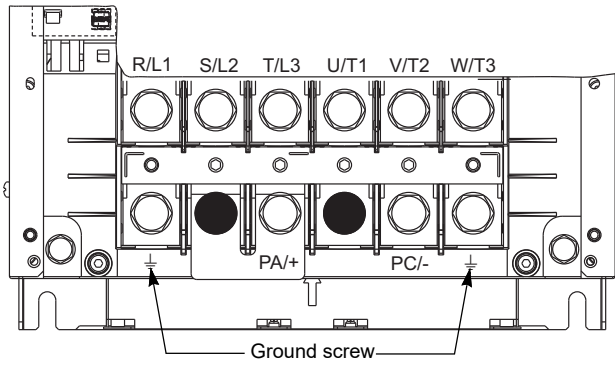

ATV212H	Maximum wire size		Tightening torque
	mm <sup>2</sup>	AWG	N·m (lb-in)
<b>D22M3X</b> <b>D22N4,</b> <b>D30N4</b>	50	1/0	24 (212.0)

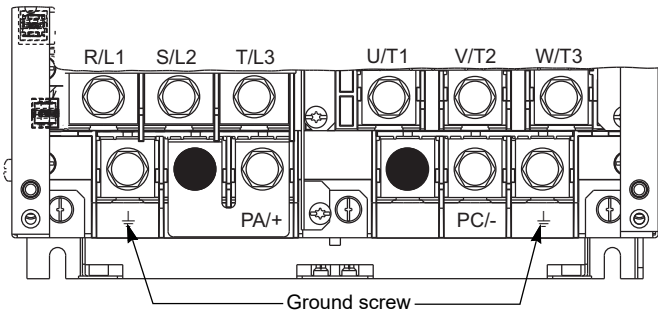

ATV212H	Maximum wire size		Tightening torque
	mm <sup>2</sup>	kcmils	N·m (lb-in)
<b>D30M3X</b>	150	300	41 (363.0)

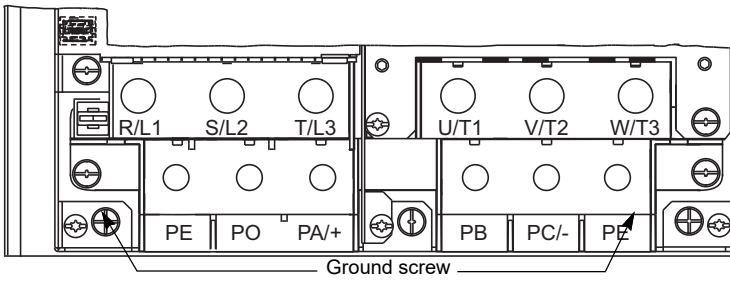

ATV212H	Maximum wire size		Tightening torque
	mm <sup>2</sup>	AWG	N·m (lb-in)
<b>D37N4,</b> <b>D45N4</b>	50	1/0	24 (212.0)

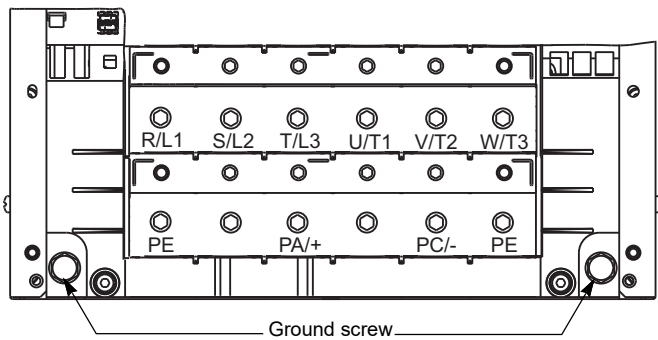

ATV212H	Maximum wire size		Tightening torque
	mm <sup>2</sup>	kcmils	N·m (lb-in)
<b>D55N4,</b> <b>D75N4</b>	150	300	41 (363.0)

## Characteristics

Terminal	Function
⏏	Ground terminal
R/L1 S/L2 T/L3	Power supply
U/T1 V/T2 W/T3	Outputs to the motor
PO (2)	DC bus (+) polarity (do not use)
PA/+ (2) (3)	DC bus (+) polarity
PB	DC bus connection (do not use)
PC/- (3)	DC bus (-) polarity



(1) ATV212 drives have two ground terminals, one on the power terminal strip and one on the heatsink.

(2) Never remove the jumper between PO and PA/+.

(3) The PA/+ and PC/- terminals can only be used to measure the DC bus voltage.

## ATV212W - Arrangement and characteristics of the power terminals

Connect the power terminals before connecting the control terminals.

- A**  Each power terminal has the structure shown in the figure at left. Connect a cable to **A** if it has a ring terminal or to **B** if it does not have a terminal (bare wire).
- B**  Parts A and B can accommodate different cable sizes.

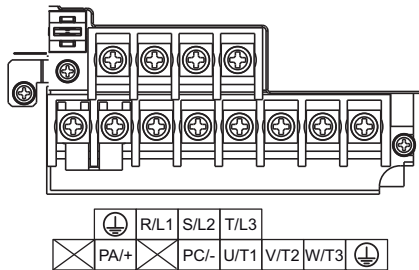

ATV212W	Maximum wire size		Tightening torque
	mm <sup>2</sup>	AWG	N·m (lb-in)
<b>075N4, U15N4, U22N4</b>	6	10	1.3 (11.5)

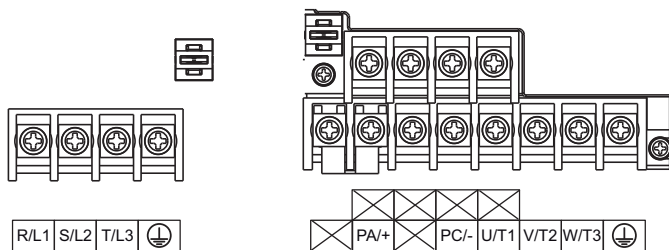

ATV212W	Maximum wire size		Tightening torque
	mm <sup>2</sup>	AWG	N·m (lb-in)
<b>075N4C, U15N4C, U22N4C</b>	6	10	1.3 (11.5)

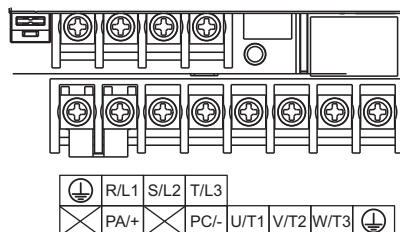

ATV212W	Maximum wire size		Tightening torque
	mm <sup>2</sup>	AWG	N·m (lb-in)
<b>U30N4, U40N4, U55N4,</b>	6	10	1.3 (11.5)

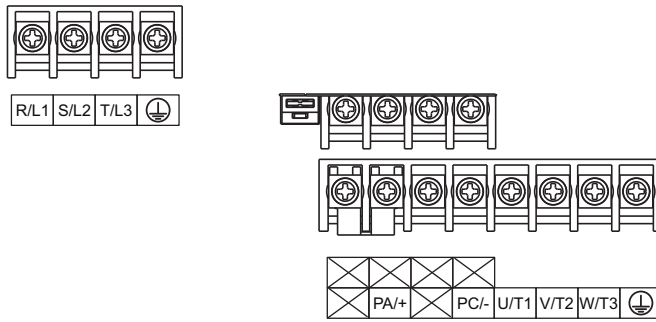

ATV212W	Maximum wire size		Tightening torque
	mm <sup>2</sup>	AWG	N·m (lb-in)
<b>U30N4C, U40N4C, U55N4C,</b>	6	10	1.3 (11.5)

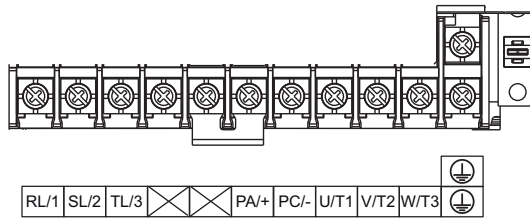

ATV212W	Maximum wire size		Tightening torque
	mm <sup>2</sup>	AWG	N·m (lb-in)
<b>U75N4, U75N4C</b>	16	6	2.5 (22)

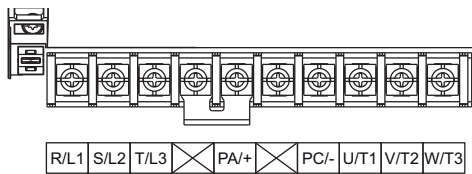

ATV212W	Maximum wire size		Tightening torque
	mm <sup>2</sup>	AWG	N·m (lb-in)
<b>D11N4, D15N4</b>	16	4	3 (26.5)

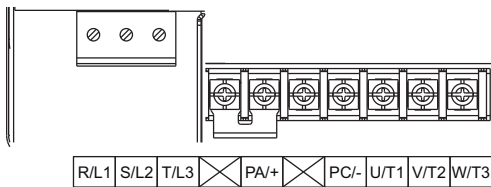

ATV212W	Maximum wire size		Tightening torque
	mm <sup>2</sup>	AWG	N·m (lb-in)
<b>D11N4C, D15N4C</b>	16	4	3 (26.5)
<b>D11N4C, D15N4C</b>	<i>10</i>	<i>6</i>	<i>4.5 (40.0)</i>

Values in italics are for terminals R/L1, S/L2, T/L3 terminals only.

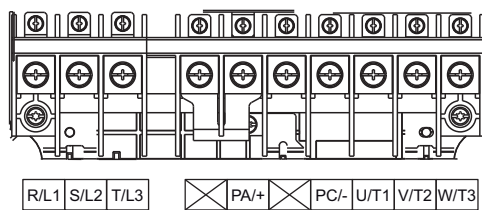

ATV212W	Maximum wire size		Tightening torque
	mm <sup>2</sup>	AWG	N·m (lb-in)
<b>D18N4, D18N4C</b>	25	3	5.4 (48)
<b>D18N4C</b>	<i>16</i>	<i>4</i>	<i>2.2 (19.5)</i>

Values in italics are for terminals R/L1, S/L2, T/L3 terminals only.

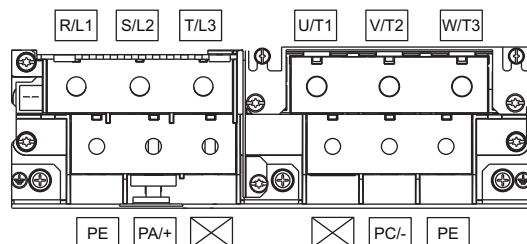

ATV212W	Maximum wire size		Tightening torque
	mm <sup>2</sup>	AWG	N·m (lb-in)
<b>D22N4, D22N4C</b>	50	1/0	24 (212)
<b>D30N4, D30N4C</b>	25	3	4.3 (38)

Values in italics are for terminals R/L1, S/L2, T/L3 terminals only.

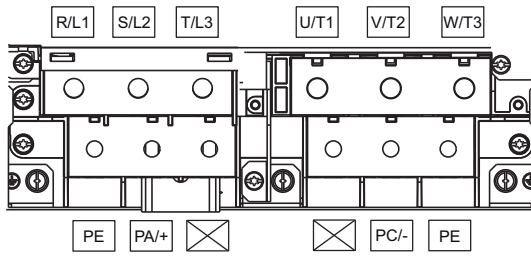

ATV212W	Maximum wire size		Tightening torque
	mm <sup>2</sup>	AWG	N·m (lb-in)
<b>D37N4, D37N4C</b>	50	1/0	24 (212)
<b>D45N4, D45N4C</b>	-	-	7 (62)

Values in italics are for terminals R/L1, S/L2, T/L3 terminals only.

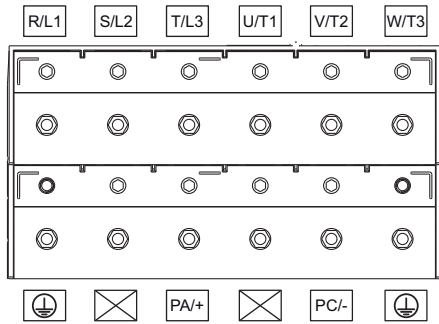

ATV212W	Maximum wire size		Tightening torque
	mm <sup>2</sup>	kcmils	N·m (lb-in)
<b>D55N4, D75N4,</b>	150	300	41 (360)

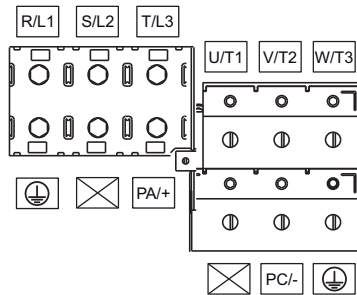

ATV212W	Maximum wire size		Tightening torque
	mm <sup>2</sup>	kcmils	N·m (lb-in)
<b>D55N4C, D75N4C</b>	150	300	41 (360)
	<i>130</i>	<i>250</i>	<i>16 (142)</i>

Values in italics are for terminals R/L1, S/L2, T/L3 terminals only.

---

## Control terminals and switches

### Preliminary recommendations

Connect the control terminals after connecting the power terminals.

The logic input switch SW102 assigns the logic input type to either 24 V (source logic) or 0 V (sink logic).

#### DANGER

##### UNINTENDED EQUIPMENT OPERATION

- Prevent accidental grounding of logic inputs configured for sink logic. Accidental grounding can result in unintended activation of drive functions.
- Protect the signal conductors against damage that could result in unintentional conductor grounding.
- Follow NFPA 79 and EN 60204 guidelines for proper control circuit grounding practices

**Failure to follow these instructions will result in death or serious injury.**

#### DANGER

##### UNINTENDED EQUIPMENT OPERATION

- Modify only the setting of switches when the product is switched off.
- Do not change the setting of switch SW102 unless your system is wired for sink logic.

**Failure to follow these instructions will result in death or serious injury.**

#### CAUTION

##### RISK OF BODY INJURY

use a screwdriver to change the position of the switches.

**Failure to follow these instructions can result in injury or equipment damage.**

Refer to "Logic Input Switch" on page [40](#) for recommended circuit diagrams for source and sink logic.

## Arrangement

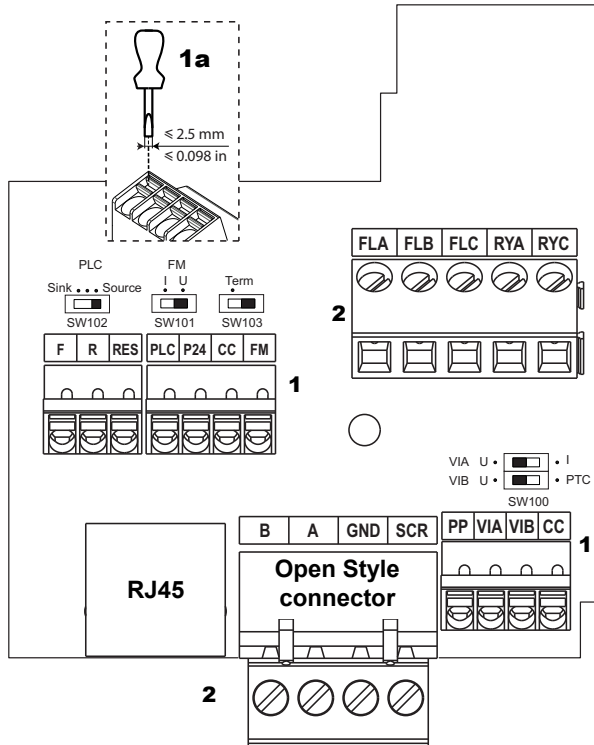

**1** spring terminals, see **1a**

**2** screw terminals

(2) When SW103 is set to Term, internal 120 Ω termination resistor is connected between A and B terminals.

Switch	Factory Setting
SW100 VIA voltage/current selection VIB voltage/PTC selection (1)	Voltage (U) Voltage (U)
SW101 (FM voltage/ current selection)	Voltage (U)
SW102 Selection of logic type	Source
SW103 Selection of communication terminal resistor (2)	 no resistor

Control terminal wire size and torque:

Applicable wire size:

- Screw terminals : 0.75 to 2.5 mm<sup>2</sup> (AWG 18 to 14)

- Spring terminals : 0.2 to 1 mm<sup>2</sup> (AWG 24 to 16)

Tightening torque:

0.5 to 0.6 N·m (4.4 to 5.3 lb-in)

(1) When SW100 is set to PTC, VIB is configured as PTC input connected to the 3.3 kΩ internal resistor. Connect the PTC probe between CC and VIB terminals.

If the 3.3 kΩ internal resistor does not suit the installation, regarding to the PTC resistor value, set SW100 to VIB, connect the PTC probe between CC and VIB terminals and add an external resistor between PP and VIB terminals.

## Characteristics

Terminals	Function	Characteristics	Default function setting
PLC	External power supply input	+24 Vdc input for external power supply for logic inputs Max. permissible voltage: 50 Vdc	
P24	Internal supply	Short-circuit and overload protection: 24 Vdc supply (min. 21 Vdc, max. 27 Vdc), maximum current: 200 mA	—
CC	Common	0 Vdc common (2 terminals)	
FLA, FLB, FLC	Configurable relay outputs	1 relay logic output, 1 N/C contact, and 1 N/O contact with common point Minimum switching capacity: 10 mA for 5 Vdc Maximum switching capacity: • On resistive load ( $\cos \varphi = 1$ ): 5 A for 250 Vac or 30 Vdc • On inductive load ( $\cos \varphi = 0.4$ and $L/R = 7$ ms): 2 A for 250 Vac or 30 Vdc Max. response time: 10 ms	Fault relay
RYA, RYC		1 relay logic output, 1 N/O contact Minimum switching capacity: 3 mA for 24 Vdc Maximum switching capacity: • On resistive load ( $\cos \varphi = 1$ ): 3 A for 250 Vac or 30 Vdc • On inductive load ( $\cos \varphi = 0.4$ and $L/R = 7$ ms): 2 A for 250 Vac or 30 Vdc Max. response time: 7 ms $\pm$ 0.5 ms	Speed attained
F R RES	Configurable logic inputs	3 programmable logic inputs, 24 Vdc, compatible with level 1 PLC, IEC 65A-68 standard Impedance: 4.7 k $\Omega$ Maximum voltage: 30 Vdc Max. sampling time: 2 ms $\pm$ 0.5 ms Multiple assignment makes it possible to configure several functions on one input	F: Run forward (2-wire control) R: Preset speed 1 command (15 Hz) RES: Clear trip
		Positive logic (Source): State 0 if $\leq 5$ Vdc or logic input not wired, state 1 if $\geq 11$ Vdc	
		Negative logic (Sink): State 0 if $\geq 16$ Vdc or logic input not wired, state 1 if $\leq 10$ Vdc	
FM	Configurable analog output	1 switch-configurable (SW101) voltage or current analog output: • Voltage analog output 0–10 Vdc, minimum load impedance 7.62 k $\Omega$ • Current analog output X–Y mA by programming X and Y from 0 to 20 mA, maximum load impedance: 970 $\Omega$ Max. sampling time: 2 ms $\pm$ 0.5 ms Resolution: 10 bits Accuracy: $\pm 1$ % for a temperature variation of 60 °C Linearity: $\pm 0.2$ %	Output frequency
PP	Internal supply available	Short-circuit and overload protection: One 10.5 Vdc $\pm$ 5% supply for the reference potentiometer (1 to 10 k $\Omega$ ), maximum current: 10 mA	—
VIA	Configurable analog/logic input	Switch-configurable voltage or current analog input: • Voltage analog input 0–10 Vdc, impedance 30 k $\Omega$ maximum voltage: 24 Vdc • Analog current input X–Y mA by programming X and Y from 0 to 20 mA, with impedance 250 $\Omega$ Max. sampling time: 3.5 ms $\pm$ 0.5 ms Resolution: 10 bits Accuracy: $\pm 0.6$ % for a temperature variation of 60 °C Linearity: $\pm 0.29$ % of the maximum value This analog input is also configurable as a logic input. Consult the Altivar 212 Programming Manual for more information.	Primary speed reference, 0–10 V
VIB	Configurable analog input	Voltage analog input, configurable as an analog input or as a PTC probe input. Voltage analog input: • 0–10 Vdc, impedance 30 k $\Omega$ max. voltage 24 Vdc • Max. sampling time: 22 ms $\pm$ 0.5 ms • Resolution: 10 bits • Accuracy: $\pm 0.6$ % for a temperature variation of 60 °C • Linearity: $\pm 0.29$ % of the maximum value PTC probe input: • 6 probes max. mounted in series • Nominal value < 1.5 k $\Omega$ • Trip resistance 3 k $\Omega$ , reset value 1.8 k $\Omega$ • Short-circuit detection threshold < 50 $\Omega$	Secondary speed reference, 1–10 V
RJ45	Graphic display terminal or Modbus	Used to connect graphic display terminal or connect the drive to a Modbus fieldbus. <b>Note:</b> For using Modbus on the RJ45, modify parameter F807. See Modbus manual.	
Open Style connector	Fieldbus	Refer to communication manual related to the fieldbus.	

### ⚠️ ⚠️ DANGER

#### HAZARD OF ELECTRIC SHOCK, EXPLOSION OR ARC FLASH

Read and understand the instructions in "before you begin" chapter, before performing the procedure in this section.

**Failure to follow these instructions will result in death or serious injury.**

### ⚠️ DANGER

#### UNINTENDED EQUIPMENT OPERATION

- Do not plug or unplug the terminal board while drive is powered.
- Check the tightening of the mounting screw after any manipulation on the terminal board.

**Failure to follow these instructions will result in death or serious injury.**

Example for installing the LONWORKS communication card in ATV212.

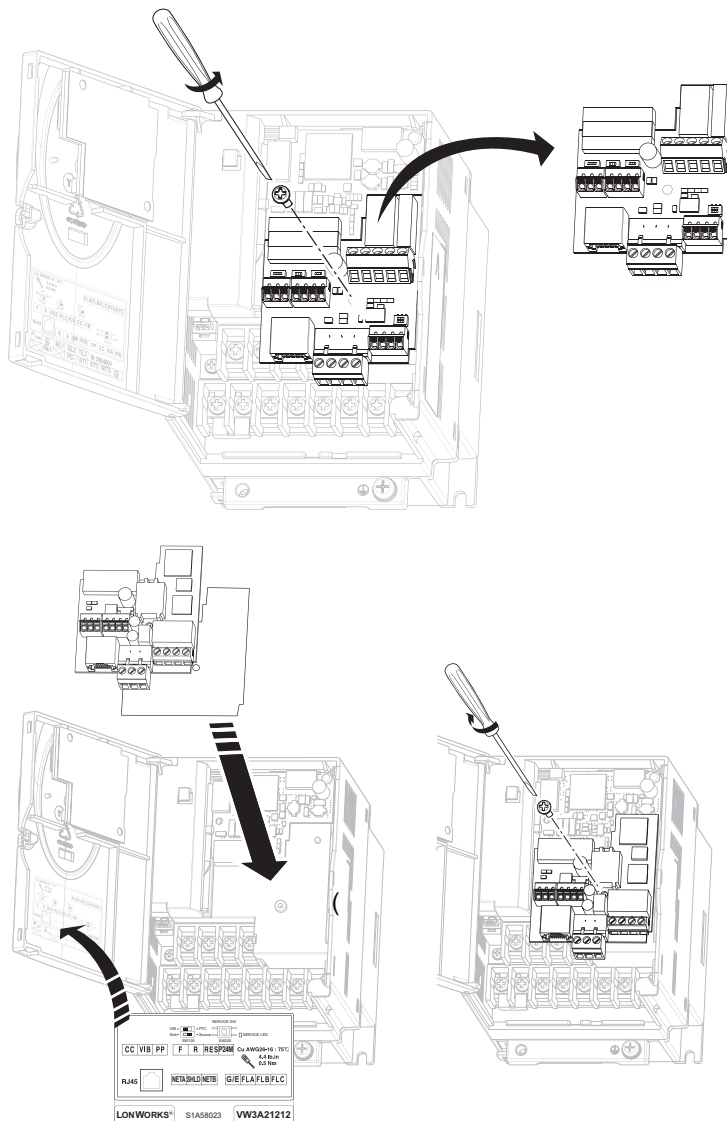

- 1 Open the ATV212 front cover, remove the terminal board mounting screw and take off the ATV212 standard terminal board. See paragraph How to open the front cover, page 52. Be careful not to lose the terminal board mounting screw when removed since it may be used again. On drives from 0.75 to 2.2 kW the board features a plastic tag to hold the mounting screw in place.
- 2 Attach the insulating sheet in ATV212. Fix to the terminal board mounting screw hole and ATV212 catch pin (a).
- 3 Install the LONWORKS communication card over the insulating sheet. Fit the board mounting screw (M3 tapping type) and tighten to 0.7 to 0.8 Nm.
- 4 Make the power and control wiring connections. For size 1 products (see page 14), connect power terminals before step 3.
- 5 Stick the cabling label for communication card on the standard cabling label stuck on front cover (internal side) ATV212. And stick the communication card nameplate close to the standard nameplate. Be careful not to cover slits on the ATV212 enclosure.

**Note:** To install or remove the terminal board, make it slide in or out in parallel with board.

## Use on an impedance grounded (IT) system

### Principle

When using the ATV212 drive on a system with an isolated or impedance grounded neutral, use a permanent insulation monitor compatible with non-linear loads, such as a XM200 type or equivalent.

### ⚠ ⚠ DANGER

#### HAZARD OF ELECTRIC SHOCK, EXPLOSION OR ARC FLASH

Read and understand the instructions in "before you begin" chapter, before performing the procedure in this section.

**Failure to follow these instructions will result in death or serious injury.**

ATV212 480 V rated drives feature built-in radio frequency interference (RFI) filters with grounded capacitors. When using the drive on an impedance grounded system, we recommend that you isolate the RFI filters from ground to help prevent reduction of their operating life.

### Jumper Location

- ATV212H075N4 to U55N4, ATV212H D22N4 to D30N4:  
Pull out the jumper to the left of the ground terminal as illustrated below to isolate the RFI filters.

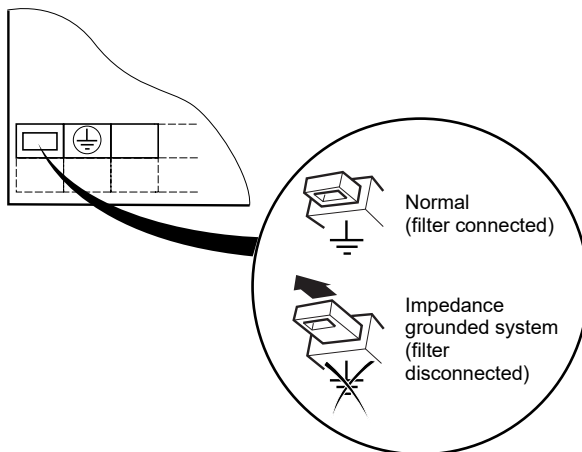

- ATV212HU75N4 to D22N4S:  
Connect the cable to the top left of the power terminals as illustrated below to isolate the filters.

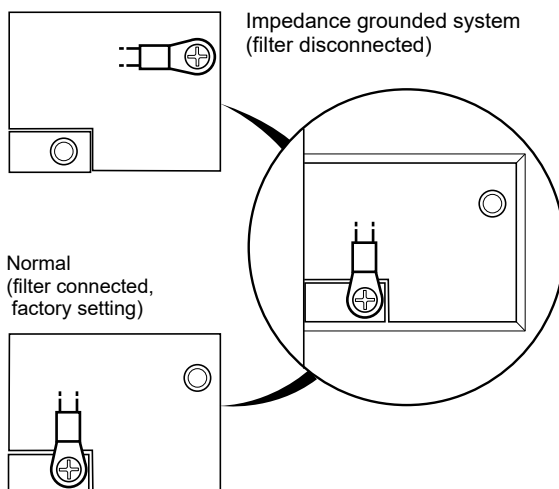

- ATV212W075N4 to U55N4 (C2, C3) and ATV212W075N4C to U55N4C (C1)

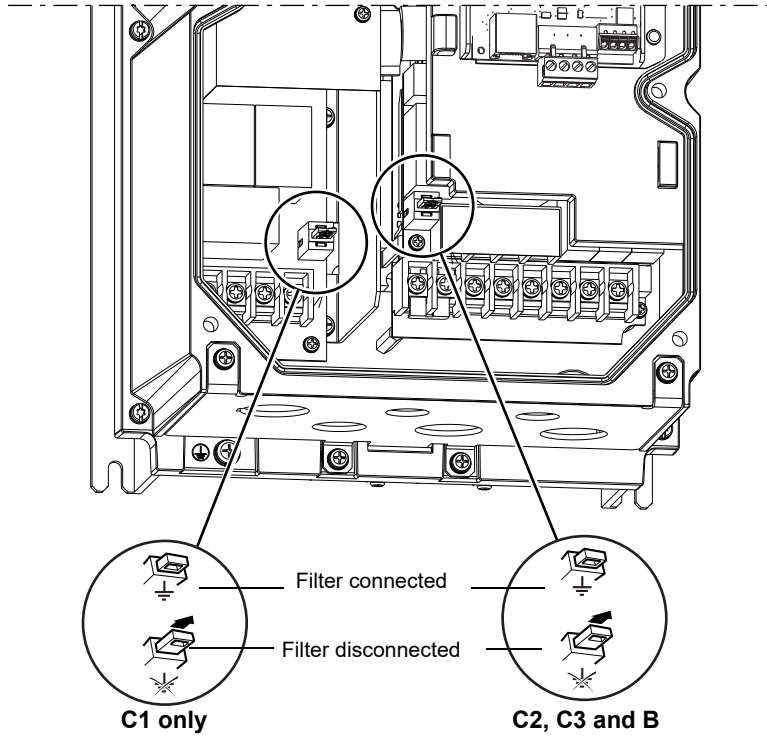

- ATV212WU75N4 (C2, C3) and ATV212WU75N4C (C1)

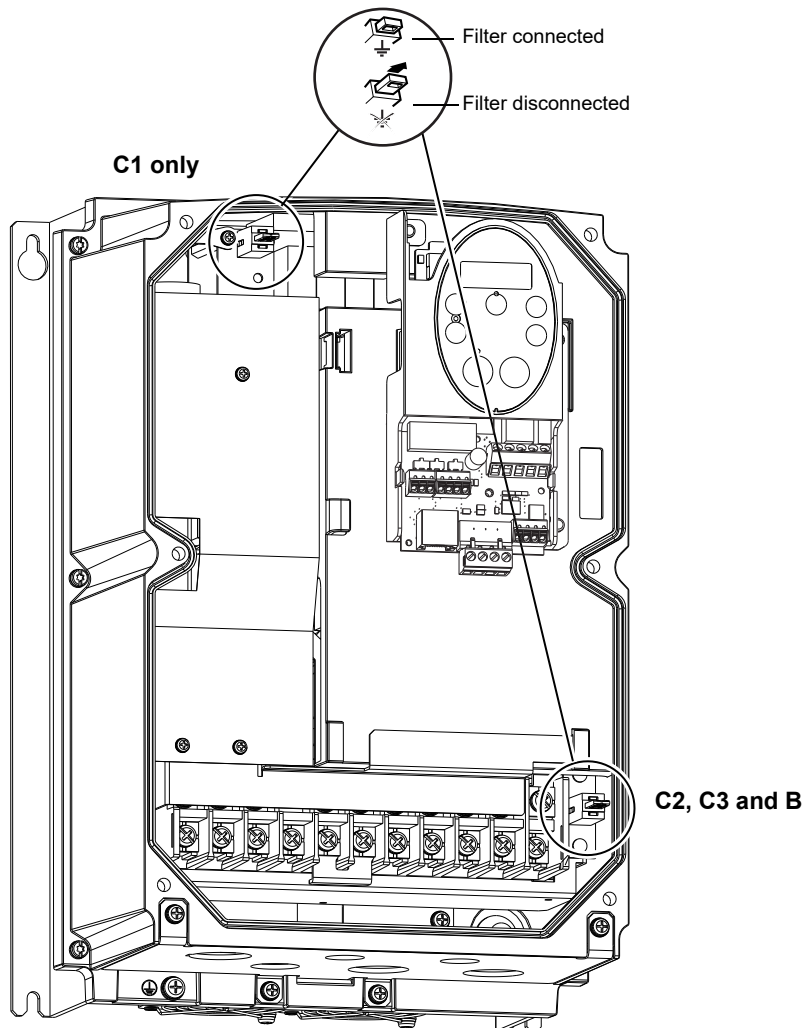

- ATV212WD11N4 to D18N4 (C2, C3) and ATV212WD11N4C to D18N4C (C1)

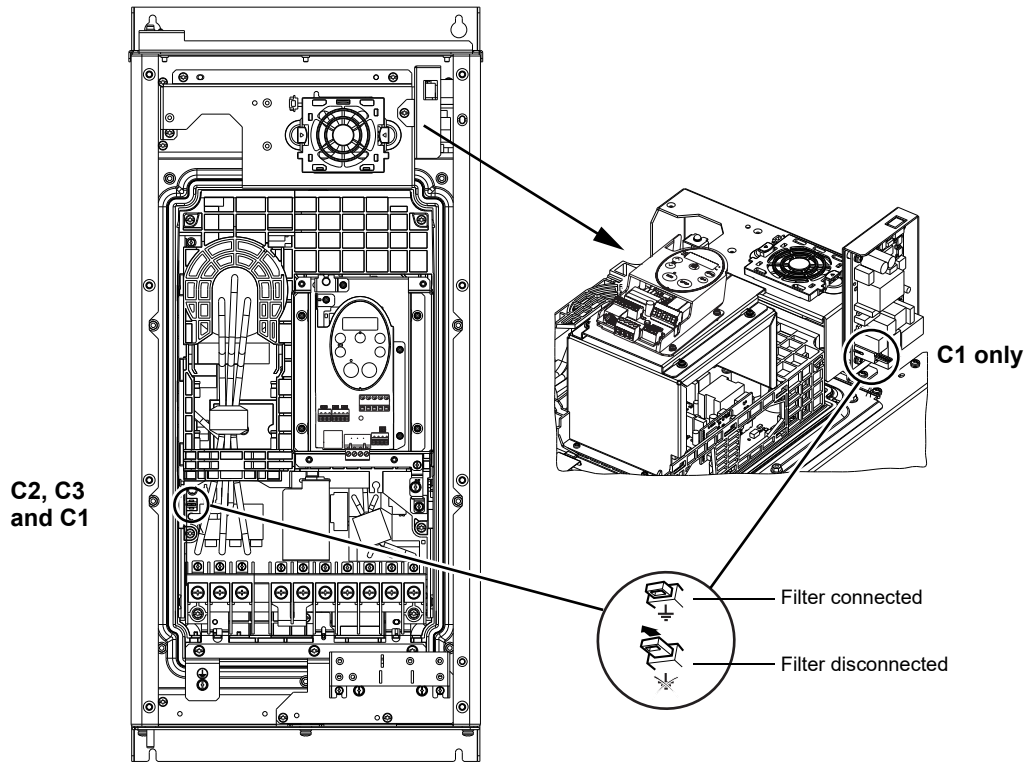

- ATV212WD22N4 to D75N4 (C2, C3)

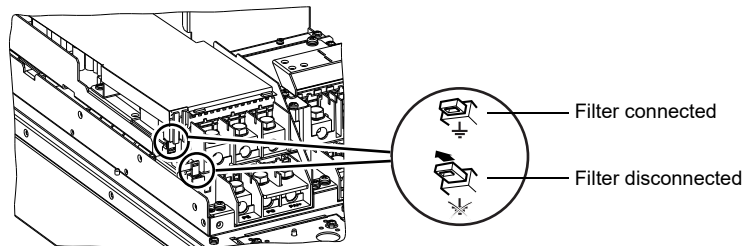

- ATV212WD22N4C to D75N4C (C1)

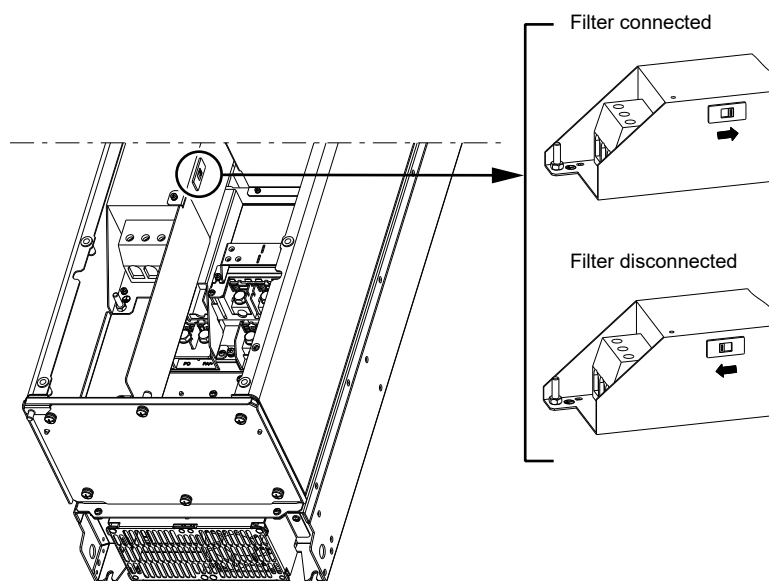

## Electromagnetic compatibility (EMC)

**NOTE:** The high frequency equipotential ground connection between the drive, motor, and cable shielding does not eliminate the need to connect the ground (PE) conductors (green-yellow) to the appropriate terminals on each unit.

### Principle and precautions

- Grounds between the drive, motor, and cable shielding must have high frequency equipotentiality.
- When using shielded cable for the motor, use a 4-conductor cable so that one wire will be the ground connection between the motor and the drive. Size of the ground conductor must be selected in compliance with local and national codes. The shield can then be grounded at both cable ends. Metal ducting or conduit can be used for part or all of the shielding length, provided there is no break in continuity.
- When using shielded cable for Dynamic Brake (DB) resistors, use a 3-conductor cable so that one wire will be the ground connection between the DB resistor assembly and the drive. The size of the ground conductor must be selected in compliance with local and national codes. The shield can then be grounded at both cable ends. Metal ducting or conduit can be used for part or all of the shielding length, provided there is no break in continuity.
- When using shielded cable for control signals, if the cable is connecting equipment that is close together and the grounds are bonded together, then both ends of the shield can be grounded. If the cable is connected to equipment that may have a different ground potential, then ground the shield at one end only to help prevent large currents from flowing in the shield. The shield on the ungrounded end may be tied to ground with a capacitor (for example: 10 nF, 100 V or higher) in order to provide a path for the higher frequency noise. Keep the control circuits away from the power circuits. For control and speed reference circuits, we recommend using shielded twisted cables with a pitch of between 25 and 50 mm (1 and 2 in.) Keep the control circuits away from the power circuits.
- Ensure maximum separation between the power supply cable (line supply) and the motor cable.
- The motor cables must be at least 0.5 m (20 in.) long.
- Do not use surge arresters or power factor correction capacitors on the variable speed drive output.
- If using an additional input filter, it should be mounted as closed as possible to the drive and connected directly to the line supply via an unshielded cable. Link on the drive is via the filter output cable.
- For installation of the EMC plate and instructions for meeting IEC 61800-3 standard, refer to the section entitled "Installing the EMC plates".

### **DANGER**

#### **HAZARD OF ELECTRIC SHOCK, EXPLOSION OR ARC FLASH**

- Do not expose cable shielding except where connected to ground at the metal cable glands and underneath the grounding clamps.
- Ensure that there is no risk of the shielding coming into contact with live components.

**Failure to follow these instructions will result in death or serious injury.**

### Mains impedance

### **NOTICE**

#### **RISK OF LIFE DURATION AND EMC PERFORMANCES DECREASE**

- Do not connect the drive to a low impedance network.
- The input withstand current must not exceed the value in the table defined in the ATV212 Quick Start Annex document, reference S1A73476 provided with the product.
- Installation and supply greater than this value will require an additional inductance.

**Failure to follow these instructions can result in equipment damage.**

## EMC Plate and cable arrangement on ATV212H drives

### ATV212H 075M3X to D18M3X ATV212H 075N4 to D22N4S

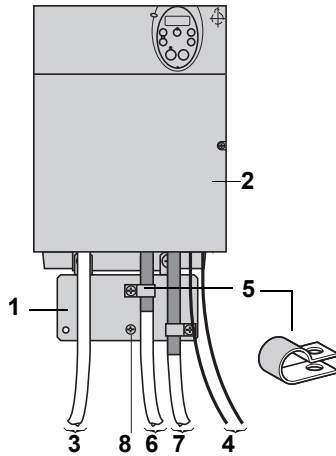

- 1 EMC plate supplied with the ATV212 drive.
- 2 ATV212 drive.
- 3 Non-shielded power supply wires or cables.
- 4 Non-shielded wires for the output of the relay contacts.
- 5 The shields for cables 6 and 7 must be securely attached to the EMC plate with stainless steel clamps not supplied with the product. See catalog to order the clamps (ref. TM200RSRCEMC). Strip cables 6 and 7 to expose the shields. Apply appropriately-sized clamps around the stripped portion of the cables and fasten them to the EMC plate.
- 6 Shielded cable for connection to the motor, with shield connected to ground at both ends. This shield must not be interrupted. If intermediate terminal blocks are used, they must be in EMC-shielded metal boxes.
- 7 Shielded cable for connection to control/command devices. For applications which require a large number of conductors, small cross-sections must be used ( $0.5 \text{ mm}^2$ , 20 AWG). This shield must not be interrupted. If intermediate terminal blocks are used, they must be in EMC-shielded metal boxes.
- 8 Ground screw. Use this screw for the motor cables on the low power rated drives, as the ground screw on the heatsink is inaccessible.

### AV212H D22M3X to D30M3X ATV212H D22N4 to D75N4

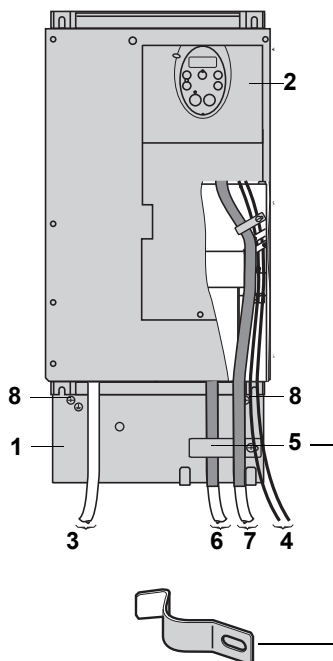

If using an additional input filter, connect it directly to the line supply with an unshielded cable. Then make connection 3 on the drive using the filter output cable.

Although there is a high frequency equipotential ground connection between the drive, motor, and cable shielding, you must still connect the PE protective conductors (green-yellow) to the appropriate terminals on each of the devices. You may also need to disconnect the shield at the motor end for very long cable runs to alleviate noise generation.

## ATV212W connection plates

There are connection plates on the lower sections of the variable speed drives. These plates are drilled in order to allow cables to be routed through them via cable glands. Cable glands must be ordered separately; **they are not supplied with the drive.**

## Mounting and connecting a shielded motor cable with metal cable gland (not supplied with the drive)

- Prepare the shielded cable by stripping both ends ready for connection.
- Loosen the cover of the cable gland.
- Attach the shielded cable to the cable gland ensuring it is fully in contact (throughout 360°).
- Fold back the shielding and clamp it between the ring and the body of the cable gland, and tighten the cover.

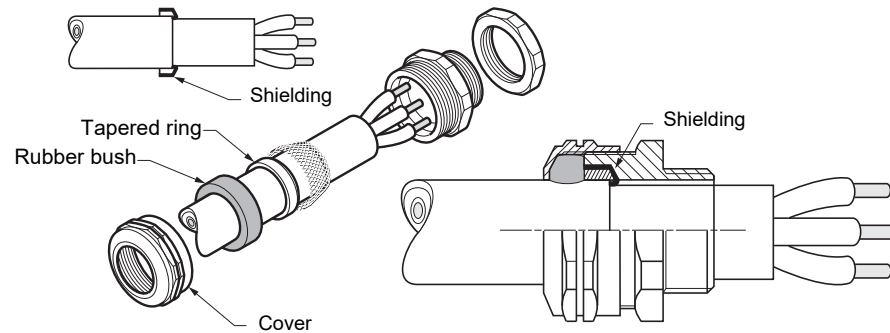

## EMC Plate and cable arrangement on ATV212W drives

### ATV212W075N4C to U55N4C

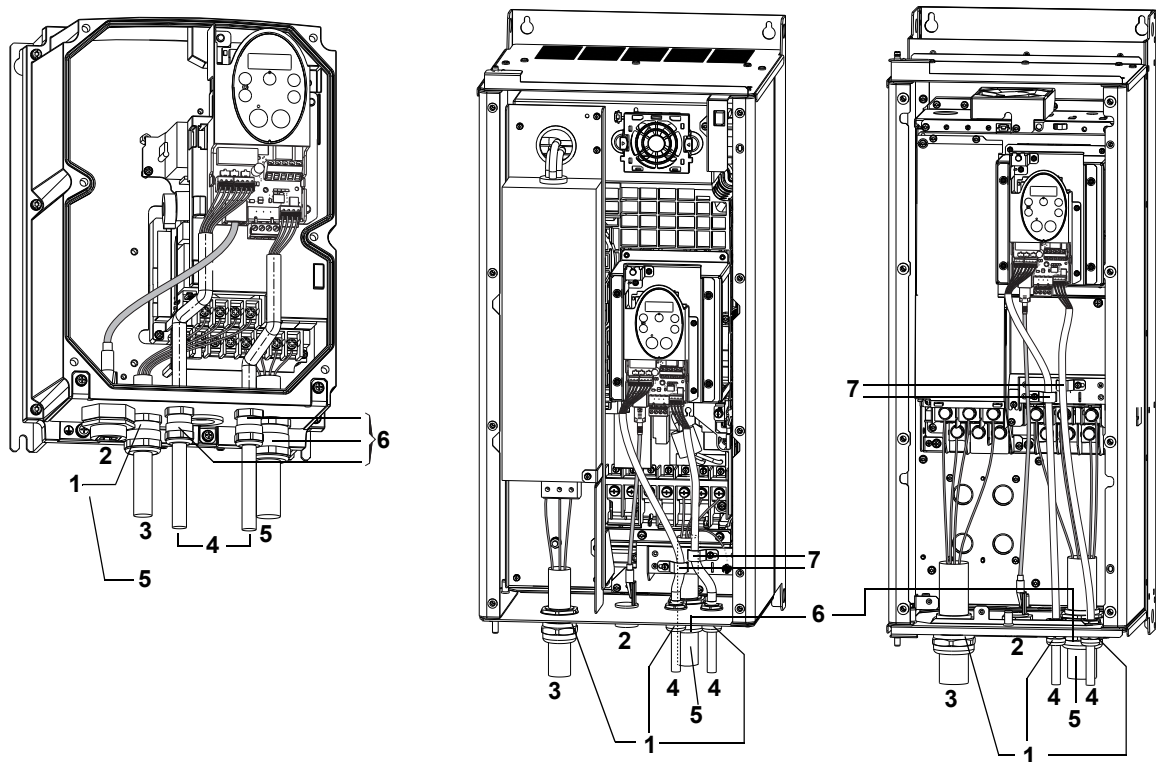

- 1 Standard cable gland (not supplied with the drive)
- 2 RJ45 connector
- 3 Unshielded power supply cable
- 4 Shielded control cables
- 5 Shielded motor cable
- 6 Metal cable glands (not supplied with the drive) for shielded control and motor cables
- 7 Metal clamps for grounding control cable shielding (shielding should be stripped)

## Using the RJ45 socket

For example, ATV212W075N4 to U75N4

Using the dust and damp proof (UL Type 12/IP55) RJ45 cable VW3A01500 and cable VW3A01501.

VW3A01500

VW3A01501



1)

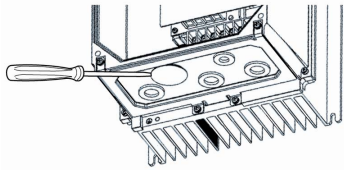

2)

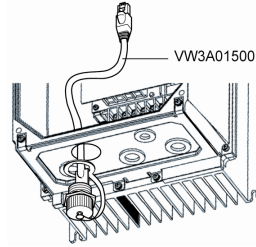

3)

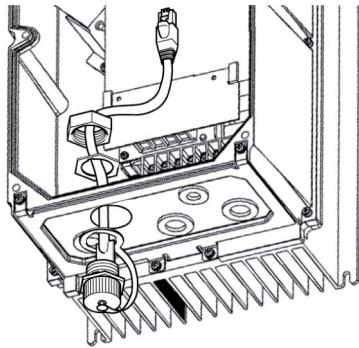

4)

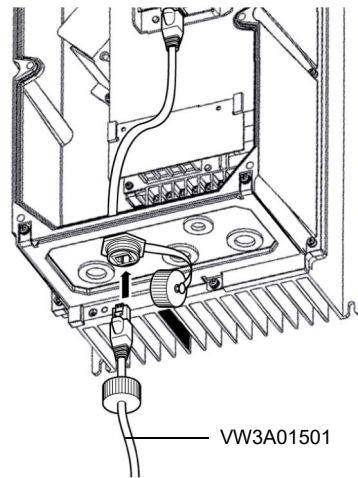

## Checking the Installation

### Before Switching On

Unsuitable settings or unsuitable data or unsuitable wiring may trigger unintended movements, trigger signals, damage parts and disable monitoring functions.

#### **WARNING**

##### **UNANTICIPATED EQUIPMENT OPERATION**

- Only start the system if there are no persons or obstructions in the zone of operation.
- Verify that a functioning emergency stop push-button is within reach of all persons involved in the operation.
- Do not operate the drive system with unknown settings or data.
- Verify that the wiring is appropriate for the settings.
- Never modify a parameter unless you fully understand the parameter and all effects of the modification.
- When commissioning, carefully run tests for all operating states, operating conditions and potential error situations.
- Anticipate movements in unintended directions or oscillation of the motor.

**Failure to follow these instructions can result in death, serious injury, or equipment damage.**

If the power stage is disabled unintentionally, for example as a result of power outage, errors or functions, there is a possibility that the motor is no longer decelerated in a controlled way.

#### **WARNING**

##### **UNANTICIPATED EQUIPMENT OPERATION**

Verify that movements without braking effect cannot cause injuries or equipment damage.

**Failure to follow these instructions can result in death, serious injury, or equipment damage.**

### Mechanical Installation

Verify the mechanical installation of the entire drive system:

Step	Action	?
1	Does the installation meet the specified distance requirements?	
2	Did you tighten all fastening screws to the specified tightening torque?	

## Electrical installation

Verify the electrical connections and the cabling:

Step	Action	?
1	Did you connect all protective ground conductors?	
2	The correct tightening of the screws may be altered during assembly and wiring phases of the drive. Verify and adjust the tightening of all terminal screws to the specified nominal torque.	
3	Do all fuses and circuit breaker have the correct rating; are the fuses of the specified type? in the Altivar Process ATV212 Quick Start guide Annex (SCCR) catalog number: <a href="#">S1A73476</a> for UL/CSA compliance and also in the catalog (see page 10) for IEC compliance.	
4	Did you connect or insulate all wires at the cable ends?	
5	Did you properly connect and install all cables and connectors?	
6	Do all plug-in terminals colors and markings correspond to the colors and marking of the control block?	
7	Did you properly connect the signal wires?	
8	Are the required shield connections EMC-compliant?	
9	Did you take all measures for EMC compliance?	
10	On floor standing products, verify that internal circuit breaker is closed	

## Covers And Seals

Verify that all devices, doors and covers of cabinet are properly installed to meet the required degree of protection.

## Recommended branch circuit protection devices

Please refer to the ATV212 Quick Start Annex document, reference S1A73476: Short Circuit Current Ratings (SCCR) and branch circuit protection.

This document is delivered with the product, and you can download it on [www.se.com](http://www.se.com).

---

# Chapter 7

## Maintenance

---

### What Is in This Chapter?

This chapter contains the following topics:

Topic	Page
Scheduled Servicing	76
Long-term Storage	77
Decommissioning	77
Additional Support	77

## Scheduled Servicing

### Servicing

#### DANGER

##### HAZARD OF ELECTRIC SHOCK, EXPLOSION OR ARC FLASH

Read and understand the instructions in **Safety Information** chapter before performing any procedure in this chapter.

**Failure to follow these instructions will result in death or serious injury.**

The temperature of the products described in this manual may exceed 80 °C (176 °F) during operation.

#### WARNING

##### HOT SURFACES

- Ensure that any contact with hot surfaces is avoided.
- Do not allow flammable or heat-sensitive parts in the immediate vicinity of hot surfaces.
- Verify that the product has sufficiently cooled down before handling it.
- Verify that the heat dissipation is sufficient by performing a test run under maximum load conditions.

**Failure to follow these instructions can result in death, serious injury, or equipment damage.**

#### WARNING

##### INSUFFICIENT MAINTENANCE

Verify that the maintenance activities described below are performed at the specified intervals.

**Failure to follow these instructions can result in death, serious injury, or equipment damage.**

Adherence to the environmental conditions must be ensured during operation of the drive. In addition, during maintenance, verify and, if appropriate, correct all factors that may have an impact on the environmental conditions.

	Part concerned	Activity	Interval (1)
Overall condition	All parts such as housing, HMI, control block, connections, etc.	Perform a visual inspection	At least every year
Corrosion	Terminals, connectors, screws, EMC plate	Inspect and clean if required	
Dust	Terminals, fans, cabinet air inlets and air outlets, air filters of cabinet	Inspect and clean if required	
	Drives filter mats Floor standing	Inspect	At least every year
		Change	At least every 4 years
Cooling	Wall mounting drives fan	Verify the fan operation	At least every year
		Replace the fan, see catalog and the instructions sheets on <a href="http://www.se.com">www.se.com</a> .	After 3 to 5 years, depending on the operating conditions
	Floor standing drives fan for power part and enclosure door fan	Replace the fans, see catalog and the instructions sheets on <a href="http://www.se.com">www.se.com</a> .	Every 35000 operating hours or every 6 years
Fastening	All screws for electrical and mechanical connections	Verify tightening torques	At least every year

**(1)** Maximum maintenance intervals from the date of commissioning. Reduce the intervals between maintenance to adapt maintenance to the environmental conditions, the operating conditions of the drive, and to any other factor that may influence the operation and/ or maintenance requirements of the drive.

---

## Diagnostic And Troubleshooting

Refer to the ATV212 Programming Manual (see page 10) available on [www.se.com](http://www.se.com)

## Spares and repairs

Serviceable product. Please refer to your Customer Care Center on:

[www.se.com/CCC](http://www.se.com/CCC).

## Long-term Storage

### Capacitor Reforming

If the drive was not connected to mains for an extended period of time, the capacitors must be restored to their full performance before the motor is started.

### **NOTICE**

#### **REDUCED CAPACITOR PERFORMANCE**

- Apply mains voltage to the drive for one hour before starting the motor if the drive has not been connected to mains for the specified periods of time (1).
- Verify that no Run command can be applied before the period of one hour has elapsed.
- Verify the date of manufacture if the drive is commissioned for the first time and run the specified procedure if the date of manufacture is more than 12 months in the past.

**Failure to follow these instructions can result in equipment damage.**

(1) Period of time:

- 12 months at a maximum storage temperature of +50°C (+122°F)
- 24 months at a maximum storage temperature of +45°C (+113°F)
- 36 months at a maximum storage temperature of +40°C (+104°F)

If the specified procedure cannot be performed without a Run command because of internal mains contactor control, perform this procedure with the power stage enabled, but the motor being at standstill so that there is no appreciable mains current in the capacitors.

## Decommissioning

### Uninstall the Product

Observe the following procedure when uninstalling the product.

- Switch off all supply voltage. Verify that no voltages are present - refer to Safety Information chapter, page 6).
- Remove all connection cables.
- Uninstall the product.

### End of Life

The components of the product consist of different materials which can be recycled and which must be disposed of separately.

- Dispose of the packaging in compliance with all applicable regulations.
- Dispose of the product in compliance with all applicable regulations.

Refer to Green Premium section ([see page 15](#)) for information and documents on environmental protection such as EoLI (End of Life instruction).

## Additional Support

### Customer Care Center

For additional support, you can contact our Customer Care Center on:

[www.se.com/CCC](http://www.se.com/CCC).



---

# Chapter 8

## Migration ATV21 --> ATV212

---

### What's in this Chapter?

This chapter contains the following topics:

Topic	Page
Generalities	80
Differentiating points	80
Terminal and switches arrangement comparison	81

## Generalities

The ATV212 is compatible with the ATV21 (latest version), nevertheless some differences exist between both drives.

## Differentiating points

### Power part

The power connections are identical to that of ATV21

### Control part overview

The control terminals are arranged and marked differently.

Furthermore ATV21 used to offer 5 different cards:

- a standard I/O card,
- 4 dedicated cards for BACnet, Metasys N2, APOGEE and LONWORKS fieldbuses.

ATV212 offers:

- as standard a communication card intended to Modbus, BACnet, Metasys N2 and APOGEE FLNP1 fieldbuses,
- a LONWORKS option card.

### Switches

ATV21 Standard I/O		ATV212 Modbus BACnet, Metasys N2, APOGEE	
Selection of logic type	SW4	Selection of logic type	SW102
FM voltage/ current selection	SW2	FM voltage/ current selection	SW101

ATV21 BACnet, Metasys N2, APOGEE		ATV212 Modbus BACnet, Metasys N2, APOGEE	
Selection of logic type	SW2	Selection of logic type	SW102
VIB function		VIB function	SW100
Selection of communication terminal resistor	SW4	Selection of communication terminal resistor	SW103

ATV21 LONWORKS		ATV212 LONWORKS	
Selection of logic type	SW1	Selection of logic type	SW100
VIB function		VIB function	

## Terminal and switches arrangement comparison

ATV21 former cards	ATV212 new cards
Standard I/O card	Standard Modbus/BACnet/Metasy N2/APOGEE FLNP1 card
<p><b>ATV21</b></p> <p style="text-align: right;">Sta</p>	<p>RJ45 factory setting:</p> <ul style="list-style-type: none"> <li>• on ATV21, to connect Modbus</li> <li>• on ATV212, to connect graphic display option.</li> </ul> <p>For ATV212, use the open style connector to connect the drive to Modbus, BACnet, APOGEE FLNP1 and Metasy N2 fieldbuses.</p> <p>Using RJ45 to connect Modbus fieldbus is still possible but requires to modify parameter <b>F B 0 7</b></p>
BACnet / Metasy N2 / APOGEE option card	Standard including ModBus / BACnet / Metasy N2 / APOGEE FLNP1 card
<p><b>ATV21</b></p> <p style="text-align: right;">BA</p>	<p><b>ATV212</b></p> <p>Standard including ModBus / BACnet / Metasy N2 / APOGEE FLNP1</p>
LONWORKS option card	LONWORKS option card
<p><b>ATV21</b></p> <p style="text-align: center;">LONWORKS VW3A21312</p>	<p><b>ATV212</b></p> <p style="text-align: center;">LONWORKS VW3A21212</p>





[www.se.com/contact](http://www.se.com/contact)