

Switch-disconnector
 Interrupteur-sectionneur
 Interruptor seccionador
 隔离开关
 Lasttrennschalter
 Interruttore di manovra-sezionatore
 Interruptor-seccionador
 Выключатель-разъединитель

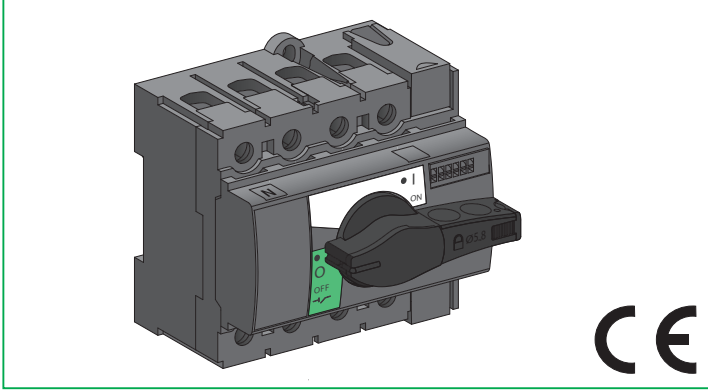

Schneider
 Electric

S1A3559100-04

<p>PLEASE NOTE</p> <ul style="list-style-type: none"> ● Electrical equipment should be installed, operated, serviced, and maintained only by qualified personnel. ● No responsibility is assumed by Schneider Electric for any consequences arising out of the use of this material. 	<p>BITTE BEACHTEN</p> <ul style="list-style-type: none"> ● Elektrische Geräte dürfen nur von Fachpersonal installiert, betrieben, bedient und gewartet werden. ● Schneider Electric haftet nicht für Schäden, die durch die Verwendung dieses Materials entstehen.
<p>REMARQUE IMPORTANTE</p> <ul style="list-style-type: none"> ● L'installation, l'utilisation, la réparation et la maintenance des équipements électriques doivent être assurées par du personnel qualifié uniquement. ● Schneider Electric décline toute responsabilité quant aux conséquences de l'utilisation de ce matériel. 	<p>NOTA</p> <ul style="list-style-type: none"> ● Manutenzione, riparazione, installazione e uso delle apparecchiature elettriche si devono affidare solo a personale qualificato. ● Schneider Electric non si assume alcuna responsabilità per qualsiasi conseguenza derivante dall'uso di questo materiale.
<p>TENGA EN CUENTA</p> <ul style="list-style-type: none"> ● La instalación, utilización, puesta en servicio y mantenimiento de equipos eléctricos deberán ser realizados sólo por personal cualificado. ● Schneider Electric no se hace responsable de ninguna de las consecuencias del uso de este material. 	<p>NOTA</p> <ul style="list-style-type: none"> ● A instalação, utilização e manutenção do equipamento eléctrico devem ser efectuadas exclusivamente por pessoal qualificado. ● A Schneider Electric não assume qualquer responsabilidade pelas consequências resultantes da utilização deste material.
<p>请注意</p> <ul style="list-style-type: none"> ● 电气设备的安装、操作、维修和维护工作仅限于合格人员执行。 ● Schneider Electric 不承担由于使用本资料所引起的任何后果。 	<p>ОБРАТИТЕ ВНИМАНИЕ</p> <ul style="list-style-type: none"> ● Установка, эксплуатация, ремонт и обслуживание электрического оборудования может выполняться только квалифицированными электриками. ● Компания Schneider Electric не несет никакой ответственности за любые возможные последствия использования данной документации.

⚠️ DANGER / DANGER / PELIGRO / 危險 / GEFAHR / PERICOLO / PERIGO / ОПАСНОСТЬ

<p>HAZARD OF ELECTRIC SHOCK, EXPLOSION OR ARC FLASH</p> <ul style="list-style-type: none"> ■ Apply appropriate personal protective equipment (PPE) and follow safe electrical work practices. See NFPA 70E, CSA Z462 or local equivalent. ■ This equipment must only be installed and serviced by qualified electrical personnel. ■ Turn off all power supplying this equipment before working on or inside equipment. Lock the switchgear in the isolated position. ■ Always use a properly rated voltage sensing device to confirm power is off. ■ Install safety barriers and display a danger sign. ■ Replace all devices, doors, and covers before turning on power to this equipment. <p>Failure to follow these instructions will result in death or serious injury.</p>	<p>RISQUE D'ÉLECTROCUTION, D'EXPLOSION OU D'ARC ÉLECTRIQUE</p> <ul style="list-style-type: none"> ■ Portez un équipement de protection personnelle adapté et respectez les consignes de sécurité électrique courantes. Reportez-vous aux normes NFPA 70E, CSA Z462 ou aux textes équivalents applicables dans votre région du monde. ■ Seul un personnel qualifié doit effectuer l'installation et l'entretien de cet appareil. ■ Débranchez toutes les sources d'alimentation de cet équipement avant d'effectuer toute opération interne ou externe sur celui-ci. Verrouillez l'appareillage en position isolée. ■ Utilisez toujours un dispositif de détection de tension ayant une valeur nominale appropriée pour vous assurer que l'alimentation est coupée ■ Installez des barrières de sécurité et affichez un signal de danger. ■ Remettez en place tous les équipements, les portes et les capots avant de remettre l'appareil sous tension. <p>Le non-respect de ces instructions provoquera la mort ou des blessures graves.</p>	<p>PELIGRO DE DESCARGA ELÉCTRICA, EXPLOSIÓN O ARCO ELÉCTRICO</p> <ul style="list-style-type: none"> ■ Utilice el equipo de protección personal (PPE) adecuado y siga las recomendaciones para el trabajo seguro con dispositivos eléctricos. Consulte NFPA 70E, CSA Z462 o la norma local equivalente. ■ Solo el personal de electricidad cualificado podrá instalar, programar y realizar el mantenimiento del equipo. ■ Desconecte toda la alimentación de este equipo antes de trabajar en él o en su interior. Bloquee la apartament eléctrica en la posición de aislamiento. ■ Utilice siempre un dispositivo de detección de tensión de capacidad adecuada para confirmar la ausencia de alimentación eléctrica. ■ Instale barreras de seguridad y coloque un cartel de peligro. ■ Vuelva a colocar todos los dispositivos, las puertas y las tapas antes de conectar la alimentación de este equipo. <p>Si no se siguen estas instrucciones provocará lesiones graves o incluso la muerte.</p>	<p>电击、爆炸或弧闪的危险</p> <ul style="list-style-type: none"> ■ 采用适当的个人防护设备 (PPE) 并遵循电气作业安全守则。请参阅 NFPA 70E, CSA Z462 或当地对应的标准。 ■ 只有具备相应资质的电气人员才能安装和维修该设备。 ■ 在该设备表面或内部工作之前, 请关闭设备的全部电源。将开关锁定在隔离位置。 ■ 确保使用合适的额定电压传感器确认电源已关闭。 ■ 安装安全栅并显示危险标志。 ■ 更换所有设备、门和盖, 然后再打开该设备的电源。 <p>不遵循上述说明将导致人员伤亡。</p>
<p>GEFAHR VON ELEKTRISCHEM SCHLAG, EXPLOSION ODER LICHTBOGEN</p> <ul style="list-style-type: none"> ■ Tragen Sie persönliche Schutzausrüstung (PSA) und befolgen Sie sichere Verfahren im Umgang mit Elektrogeräten. Siehe NFPA 70E, CSA Z462 oder lokale Entsprechung. ■ Diese Geräte dürfen nur von qualifizierten Elektrikern installiert und gewartet werden. ■ Schalten Sie vor Arbeiten am bzw. im Innern des Geräts die gesamte Spannungsversorgung ab. Die Schaltanlage in die Trennstellung bringen. ■ Verwenden Sie für die Prüfung vorhandener Spannung stets einen Spannungsfühler mit zutreffender Bemessungsspannung. ■ Bringen Sie Sicherheitsbarrieren und einen Warnhinweis an. ■ Bringen Sie alle Vorrichtungen, Türen und Abdeckungen wieder an, bevor Sie das Gerät einschalten. <p>Die Nichtbeachtung dieser Anweisungen führt zu Tod oder schwerer Körperverletzung.</p>	<p>RISCHIO DI FOLGORAZIONE, ESPLOSIONI O ARCO ELETTRICO</p> <ul style="list-style-type: none"> ■ Utilizzare dispositivi di protezione individuale (DPI) idonei e adottare misure di sicurezza adeguate per lavori elettrici. Vedere le normative NFPA 70E, CSA Z462 o le norme equivalenti nel paese di installazione. ■ Installazione e manutenzione di questa apparecchiatura si devono affidare solo ad elettricisti qualificati. ■ Prima di lavorare con l'apparecchiatura o al suo interno isolare completamente l'alimentazione elettrica. Bloccare l'interruttore in posizione isolata. ■ Per verificare che l'alimentazione sia isolata usare sempre un rivelatore di tensione correttamente tarato. ■ Installare barriere di sicurezza e apporre un segnale di pericolo. ■ Sostituire dispositivi, sportelli e coperture prima di riaccendere l'alimentazione dell'apparecchiatura. <p>Il mancato rispetto di queste istruzioni provocherà morte o gravi infortuni.</p>	<p>RISCO DE ELECTROCUSSÃO, DE EXPLOÇÃO, OU DE ARCO ELÉCTRICO</p> <ul style="list-style-type: none"> ■ Utilize equipamento de protecção pessoal (PPE) e siga os métodos de segurança eléctrica. Consulte NFPA 70E, CSA Z462 ou o equivalente local. ■ A instalação e manutenção deste equipamento só devem ser efectuadas por electricistas qualificados. ■ Desligue todas as fontes de alimentação deste equipamento antes de trabalhar no equipamento ou no seu interior. Bloqueie a placa de distribuição na posição isolada. ■ Utilize sempre um dispositivo de detecção da tensão nominal adequada para confirmar se a alimentação está desligada. ■ Instale barreiras de segurança e apresente um sinal de perigo. ■ Substitua todos os dispositivos, portas e tampas antes de ligar a alimentação deste equipamento. <p>A não observância destas instruções resultará em morte, ou ferimentos graves.</p>	<p>ОПАСНОСТЬ ПОРАЖЕНИЯ ЭЛЕКТРИЧЕСКИМ ТОКОМ, ВЗРЫВА ИЛИ ВСПЫШКИДУГИ</p> <ul style="list-style-type: none"> ■ Используйте подходящие средства индивидуальной защиты (СИЗ) и соблюдайте технику безопасности при электротехнических работах. См. NFPA 70E, CSA Z462 или местный эквивалентный стандарт. ■ Данное оборудование могут устанавливать и обслуживать только квалифицированные электрики. ■ Отключите питание до начала работы снаружи или внутри оборудования. ■ Переведите переключатель в изолированное положение. ■ Всегда пользуйтесь надлежащим датчиком номинального напряжения для определения отсутствия питания. ■ Установите защитные ограждения и знак опасности. ■ Установите обратно все устройства, дверцы и крышки перед включением питания данного оборудования. <p>Несоблюдение этих инструкций приведет к смерти или серьезной травме.</p>

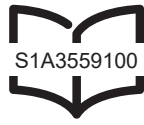
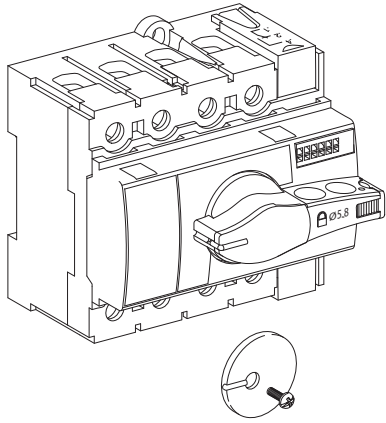

- 2 (M4)
- 2 (M4 x 10)

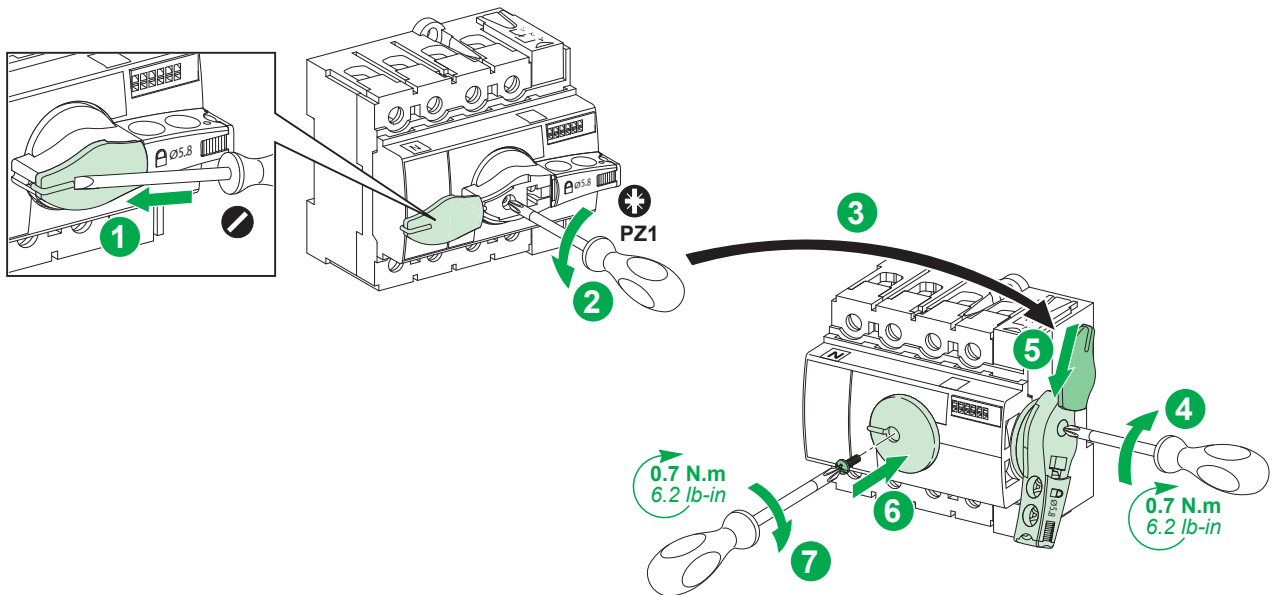
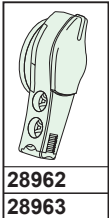
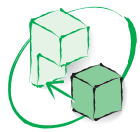
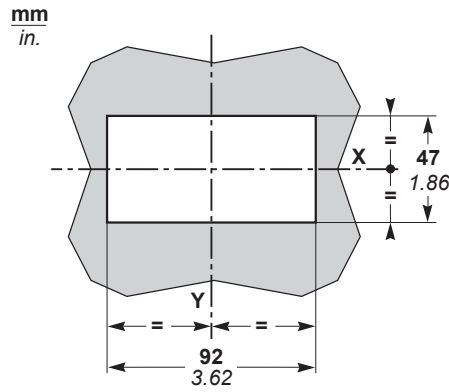
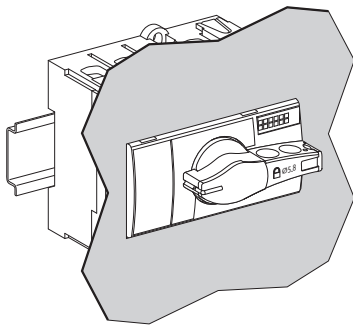
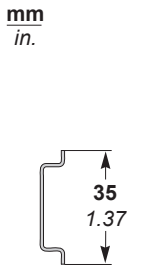
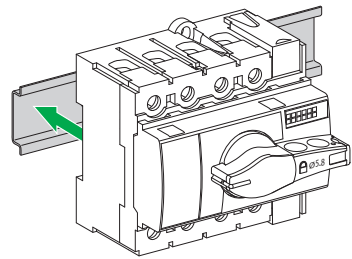
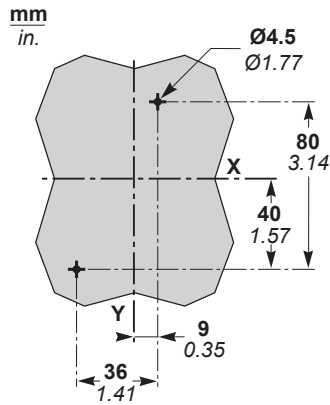
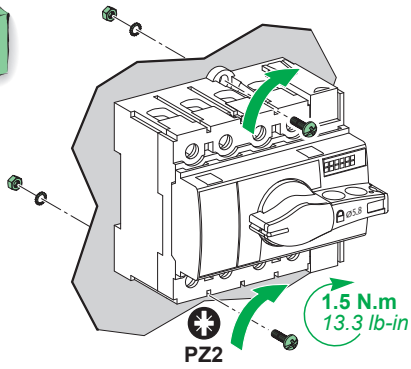
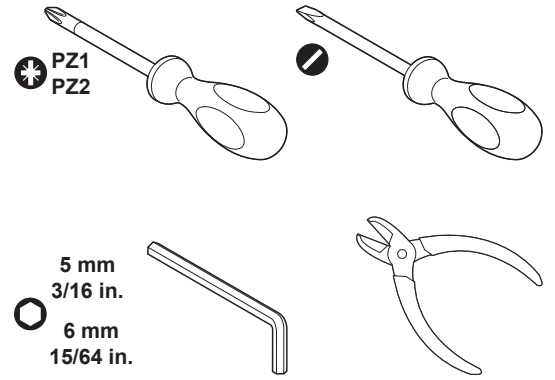

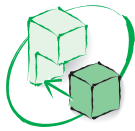

29450
29452

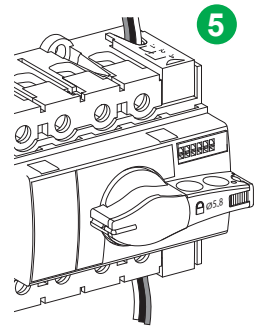
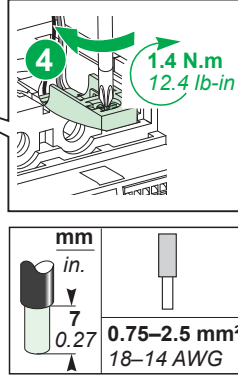
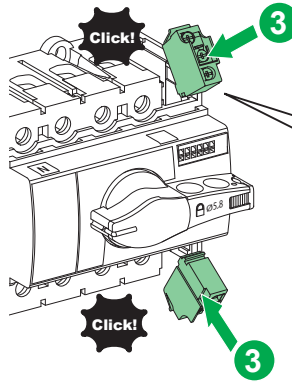
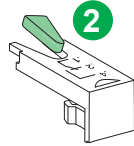
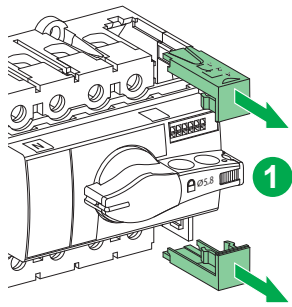

mm	in.
7	0.27
0.75–2.5 mm ²	18–14 AWG

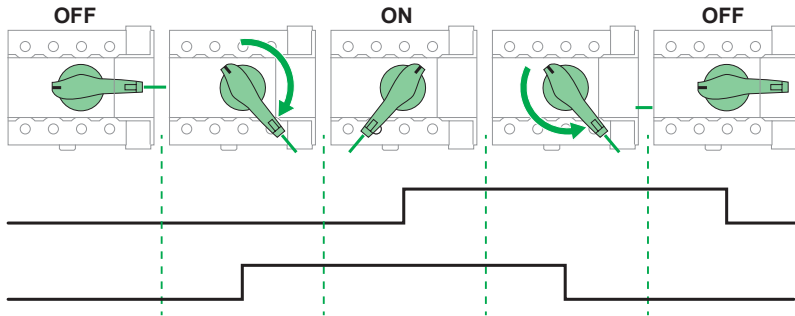

OFF open ouvert abierto 断开 open aperto abrir разомкнут	ON close fermé cerrado 闭合 geschlossen chiuso fechar замкнут	Q main contacts contacts principaux contactos principales 主触点 Hauptkontakte contatti principali contatos principais главные контакты	CAM early make or break contact avancé à la manœuvre contacto avanzado 预合或预分 Frühschließer oder Frühöffner contatto/interruzione avanzato marca ou falha inicial определение работоспособности на раннем этапе
---	--	---	---

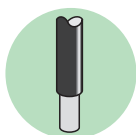
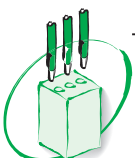
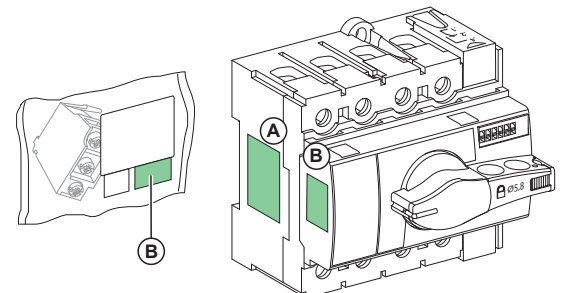
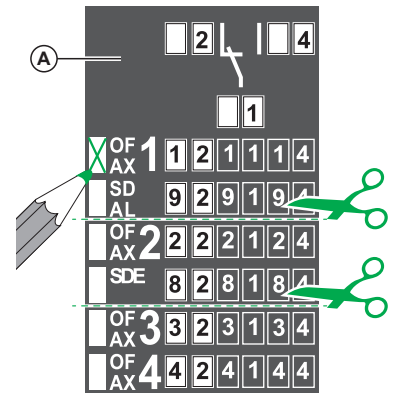

mm	in.
13	0.5
1.5–5.0 mm ²	16–1/0 AWG

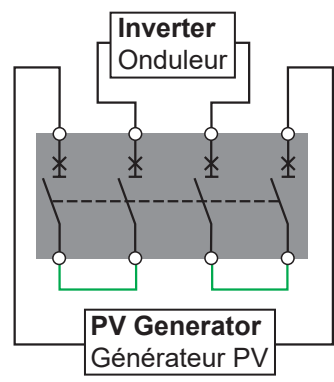
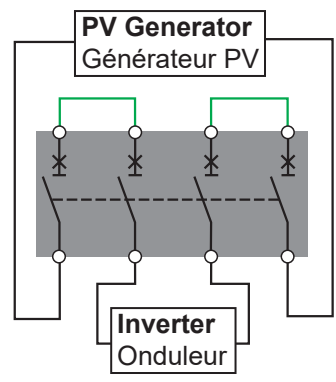
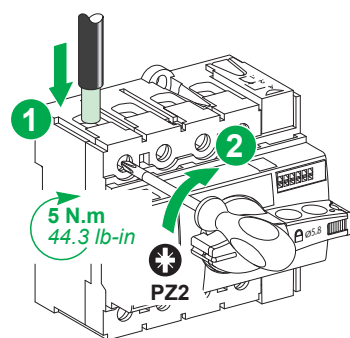



Terminal shield or interphase barriers mandatory for $U > 500\text{ V}\sim$
 Cache-borne ou séparateur de phases obligatoire pour $U > 500\text{ V}\sim$
 Cubrebornes o separadores de fase obligatorios para $U > 500\text{ V}\sim$
 $U > 500\text{ V}\sim$ 时必须采用端子屏罩或相间隔板
 Klemmenabdeckung oder Phasentrenner sind obligatorisch für $U > 500\text{ V}\sim$
 Protezione morsetteria o separatori di fase obbligatori per $U > 500\text{ V}\sim$
 Blindagem do terminal ou barreiras de interfase mandatórias para $U > 500\text{ V}\sim$
 Применение изолятора клеммы или межфазных перегородок обязательно для $U > 500\text{ В}\sim$

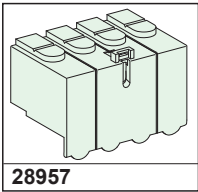

28957



LV429375

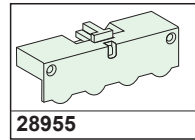
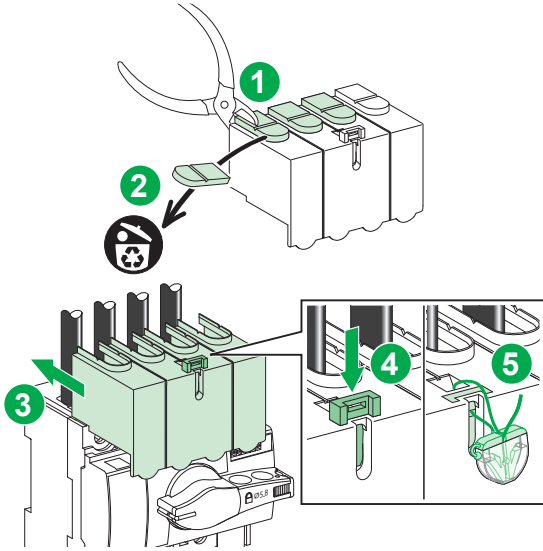

28955



LV429375

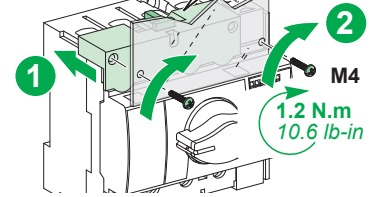
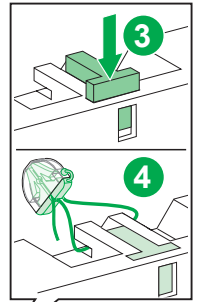

M4
1.2 N.m
10.6 lb-in



OFF

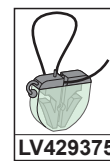
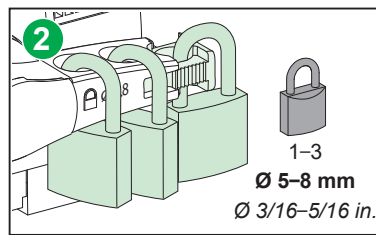
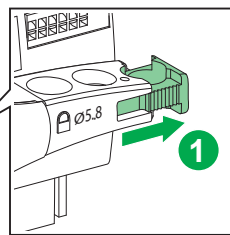
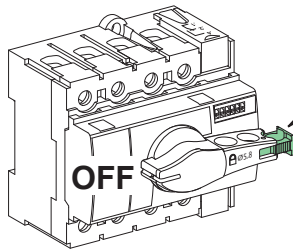

LV429375

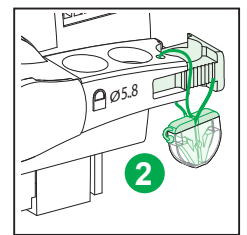

i

ON

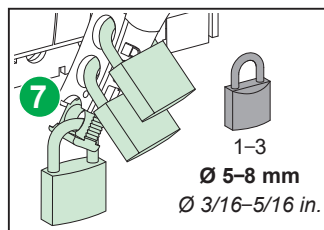
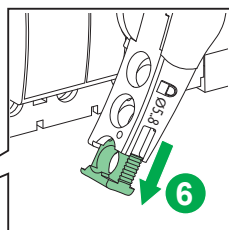
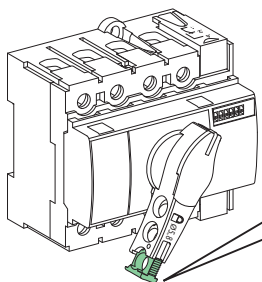
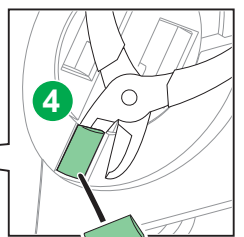
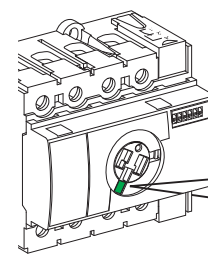
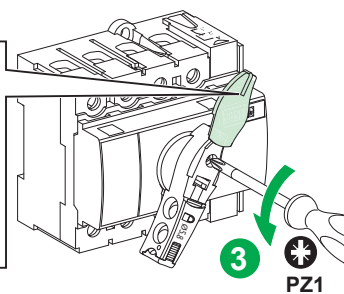
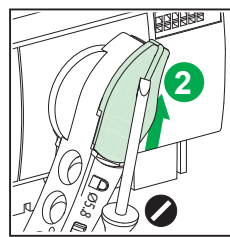
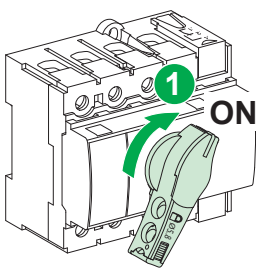

Schneider Electric Industries SAS
 35, rue Joseph Monier
 CS 30323
 F - 92506 Rueil Malmaison Cedex
 www.se.com

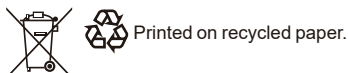

Printed on recycled paper.

Schneider Electric Limited
 Stafford Park 5
 Telford, TF3 3BL
 United Kingdom
 www.se.com/uk



Уполномоченный поставщик в РФ:
 АО «Шнейдер Электрик»
 Адрес: 127018, г. Москва, ул.
 Двинцев, д.12, корп.1,
 тел. +7 (495)777 99 88,
 факс: +7 (495)777 99 94, 8-800-200-6446
 www.se.com/ru

