

RITTO™

TwinBus IP

Door station

Installation Guide

en

In this document you will find all information for safe installation.

RGE20151xx, RGE20152xx

2023/01

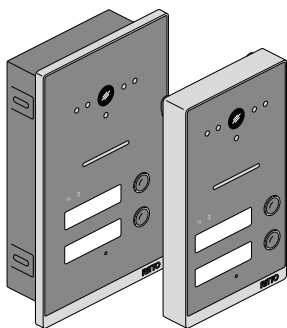

www.ritto.de

Schneider
Electric

Table of contents

For your safety.	4
About this document	4
Scope of supply	4
Introduction to the TwinBus IP Door station	5
Device overview	5
Front	5
Rear	6
The right place to install	7
Installation	8
Flush-mounted installation.	8
Surface-mounted installation	12
Pin assignment	15
Wiring diagrams / Block diagrams.	16
Single-family house	16
Wiring diagram.	16
Block diagram	18
2-family house	19
Wiring diagram.	19
Block diagram	21
Technical data	22
WEEE	23

Safety instructions

Read these instructions carefully and familiarize yourself with the device before installing or operating it. The following specific instructions may appear in this manual or on the device to warn against potential dangers or to draw attention to information that explains or simplifies a procedure.

 The addition of this symbol to the „danger“ or „warning“ precautions informs about an electrical danger which may cause serious injury if the instructions are not followed.

 This is a safety warning symbol. It informs you about possible risks of injury. Follow all safety instructions with this symbol to avoid potential injury or fatal injury.

DANGER

DANGER refers to an immediately dangerous situation which, if not observed, will **lead** to serious injuries or death.

WARNING

WARNING points to a dangerous situation which may **lead to serious injury or death** if not avoided.

CAUTION

CAUTION indicates a dangerous situation which may lead to minor or moderate injuries if not avoided.

NOTICE

A **NOTICE** indicates that there is no risk of injury.

Additional comments



More information can be found here to make your work easier.

For your safety

⚠ ⚠ DANGER

Hazard of electric shock, or arc flash

Safe electrical installation must be carried out only by skilled professionals. Skilled professionals must prove profound knowledge in the following areas:

- Connecting to installation networks
- Connecting several electrical devices
- Laying electric cables
- Safety standards, local wiring rules and regulations

Failure to follow these instructions will result in death or serious injury.

About this document

In this document you will find all information for safe installation.



For more detailed product information, such as start-up or settings, follow the QR code.



<https://www.merten.de/profibereich/service/downloads.html>

Scope of supply

Door station, wall box for flush mount, fixing material for surface mounting, installation guide

Introduction to the TwinBus IP Door station

The TwinBus IP door station (hereinafter referred to as the **door station**) is a video door station for a maximum of 2 residential units. The door station is available for surface-mounted or flush-mounted installation.

Device overview

Front

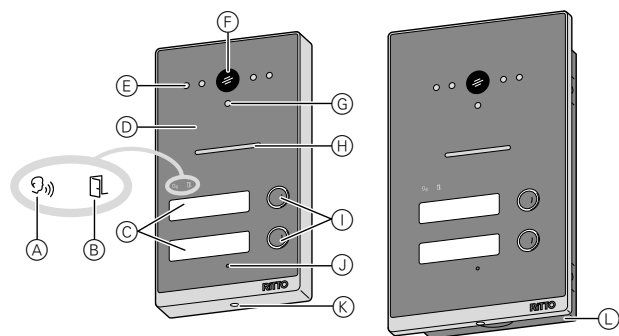

- | | |
|---|--|
| Ⓐ Indication conversation active | Ⓕ Camera |
| Ⓑ Indication door opener active | Ⓖ Lighting sensor |
| Ⓒ Illuminated name plates (number according to version) | Ⓗ Speaker |
| Ⓓ Front panel | Ⓘ Illuminated call buttons (number according to version) |
| Ⓔ Night lighting | ⓵ Microphone |
| | Ⓚ Fixing screw front panel |
| | Ⓛ Wall box for flush mount |

en

Rear

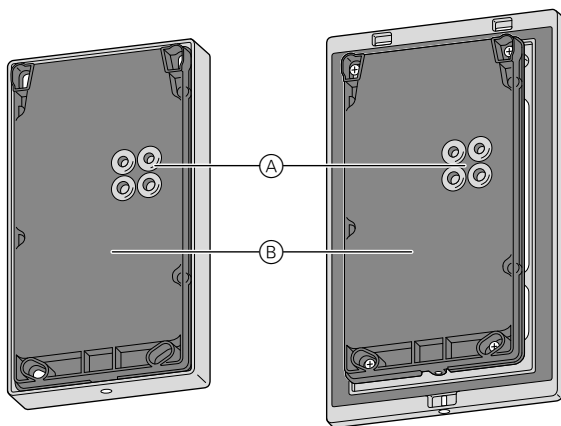

Ⓐ Cable entries with different opening diameters

Ⓑ Rear panel of the housing

The right place to install

When choosing the installation location, the maximum cable length must be observed. The following table shows the lengths from the door station to the system components

	Group of cables		
	0.8 mm	0.6 mm	0.5 mm
REG bus filter	80 m	60 m	50 m
Video indoor station	200 m	140 m	100 m
External device for opening the door (optional, e.g. card reader)	30 m	30 m	30 m
Door opener*	50 m	50 m	50 m
External power supply for door opener*	50 m	50 m	50 m

Group 0.8 mm cable: YR 2x0.8 mm, J-Y(ST)Y 2x2x0.8 mm, A-2Y(L)2Y 2x2x0.8 mm, CAT5e / CAT6 0.8 mm

Group 0.6 mm cable: A-2Y(L)2Y 2x2x0.6 mm, J-Y(ST)Y 2x2x0.6 mm, CAT5e / CAT6 0.8 mm

Group 0.5 mm cable: CAT5e / CAT6 0.5 mm

When using a shielded cable, the shield must not be connected.

* If the cable length to the door opener exceeds 80 m, an additional power supply (DC 24 V... 28 V, 2.5 A) is required.

Installation

Flush-mounted installation

NOTICE

Before starting the installation, all activities concerning the surface of the wall (e.g. plastering, wall cladding) must be completed.

- ① Trace the exact dimensions of the wall box for flush mount onto the wall by using the wall box as a template.
- ② Finish the mounting opening for the wall box.

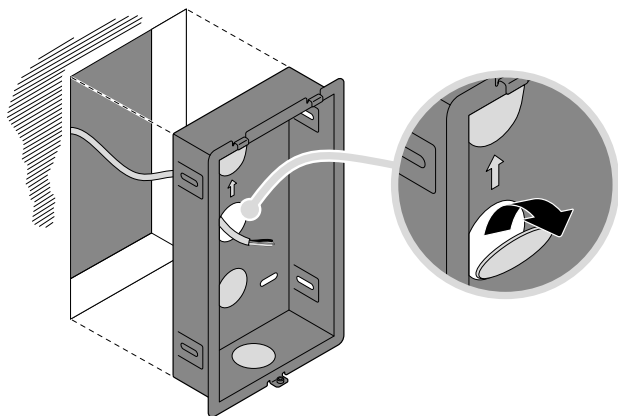

- ③ Mount the wall box in a way that its edges are flush on the wall to prevent moisture from penetrating.

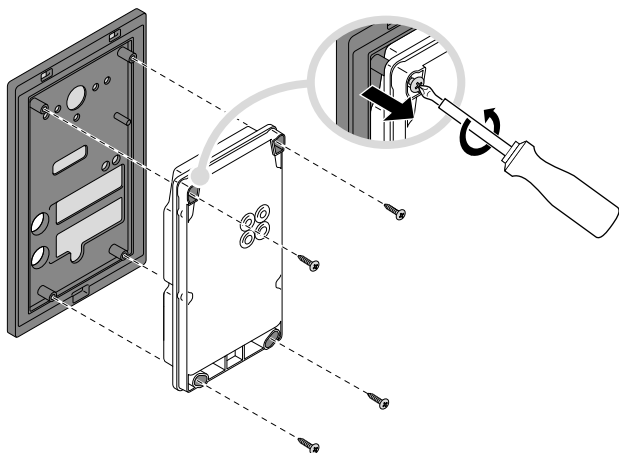

- ④ Remove the front panel of the door station.

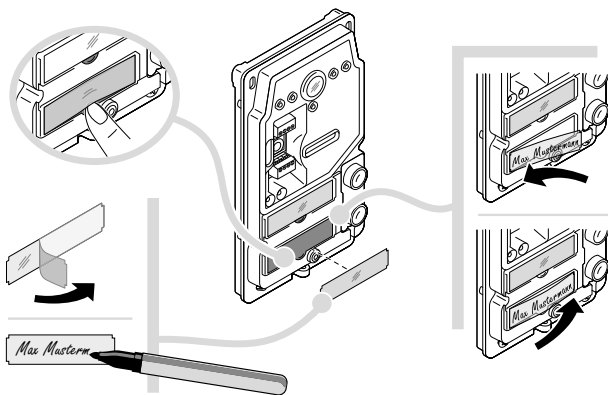

- ⑤ Label the name tag and slide it into the slot.

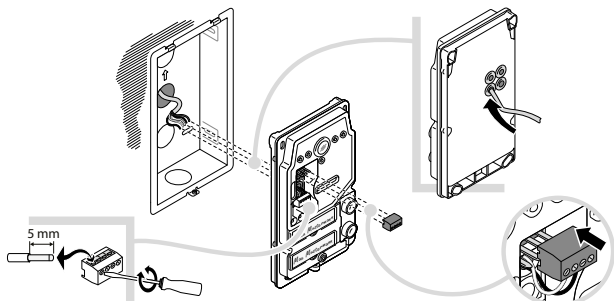

- ⑥ Feed cable with sheath from behind through the cable entry of the rear panel.
- ⑦ Perform connection according to the wiring diagram.

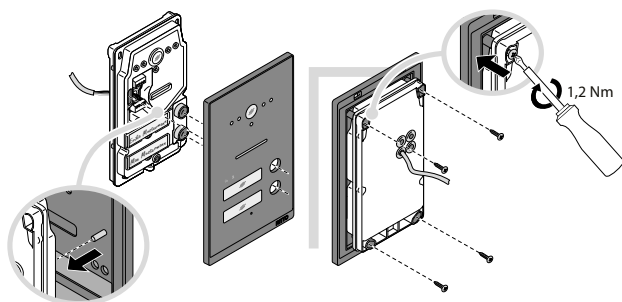

- ⑧ Screw the front plate on.

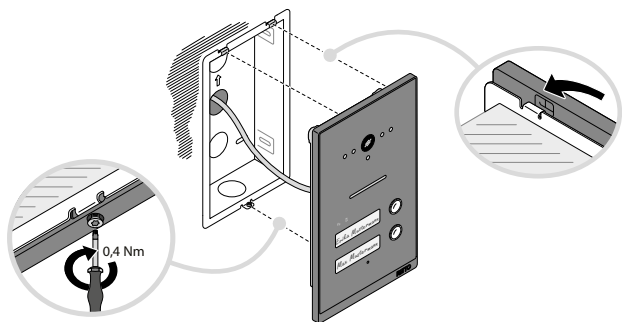

⑨ Insert the door station into the wall box.

⑩ Screw the door station to the wall box.

Surface-mounted installation

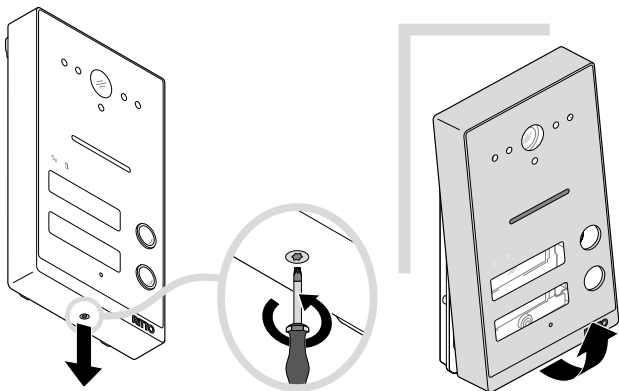

- ① Remove the front panel of the door station.

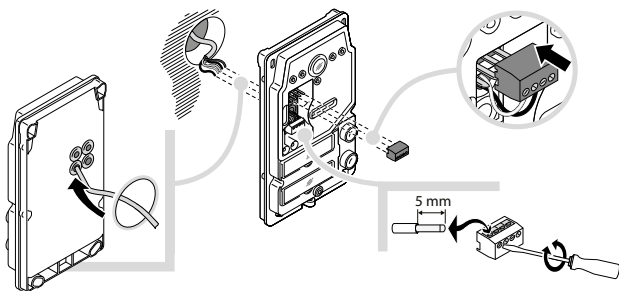

- ② Feed cable with sheath from behind through the cable entry of the rear panel.
- ③ Perform connection according to the wiring diagram.

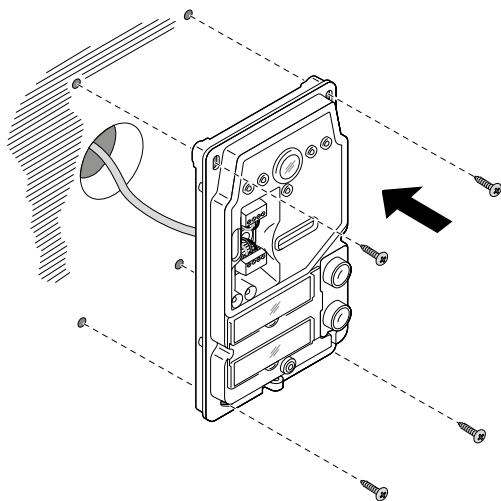

- ④ Attach the rear panel to the wall.

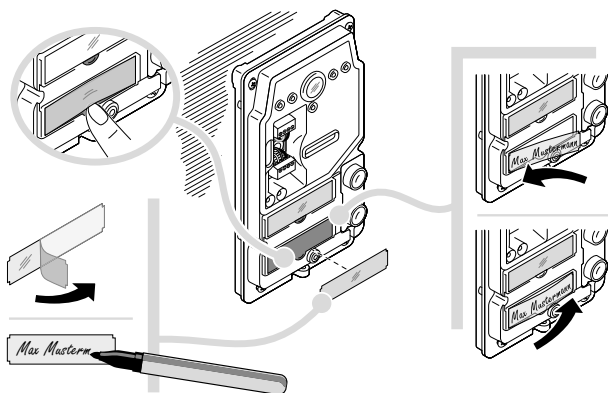

- ⑤ Label the name tag and slide it into the slot.

en

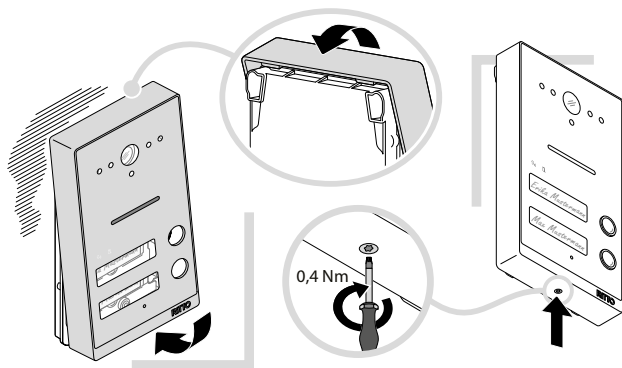

- ⑥ Place the front plate on the rear panel.
- ⑦ Screw the face plate to the rear panel.

Pin assignment

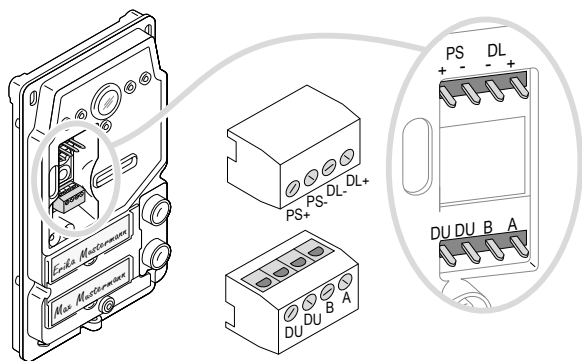

- PS + Power Supply (optional)
- PS - Power Supply (optional)
- DL - Door opener
- DL + Door opener
- DU External device, e.g. card reader
- B Bus -
- A Bus +

Wiring diagrams / Block diagrams

The system configuration can be executed in star or bus structure.

Single-family house

Wiring diagram

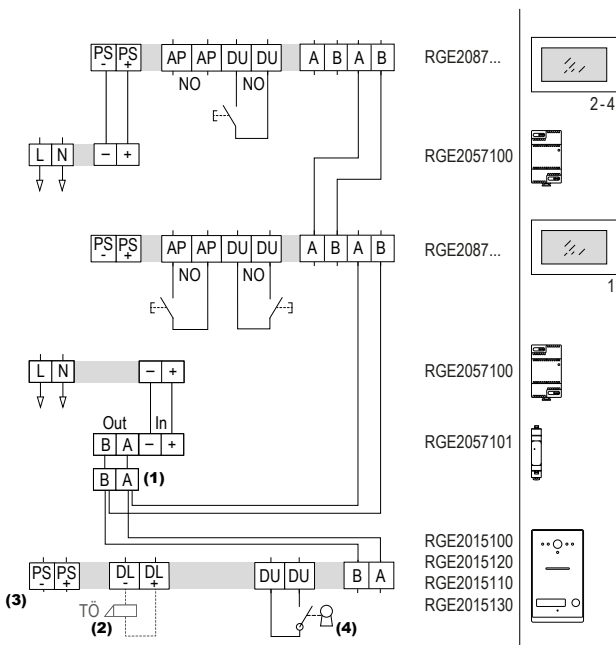

- (1) Terminal strip
 - (2) Door opener, DC 6 V ... 12 V, max. 800 mA
 - (3) **⚠ WARNING** Danger to life due to electric shock
 - Use only a SELV power supply.**Failure to comply with this instruction may result in death or serious injury.**

Connection of an additional power supply (DC 24 V ... 28 V, 2,5 A) if the cable length from the door station to the door opener exceeds 80 m.
 - (4) For example, an external card reader
- NO Normally open contacts of the indoor station: Connection of a push-button to unlock the door (DU) and to connect an apartment button ED (AP).
- TÖ Door opener

Power supply of the system:

One REG power supply RGE2057100 can supply the following components:

- REG bus filter, 1 video indoor station and 1 door station with door opener at the A Bus +/B Bus - connection or
- 3 video indoor stations at the PS+/PS- connection

Minimum system configuration:

1x video indoor station, 1x door station, 1x REG bus filter, 1x REG power supply

Maximum system configuration:

Minimum system configuration plus max. 3 further video indoor stations powered by 1 additional REG power supply.

Block diagram

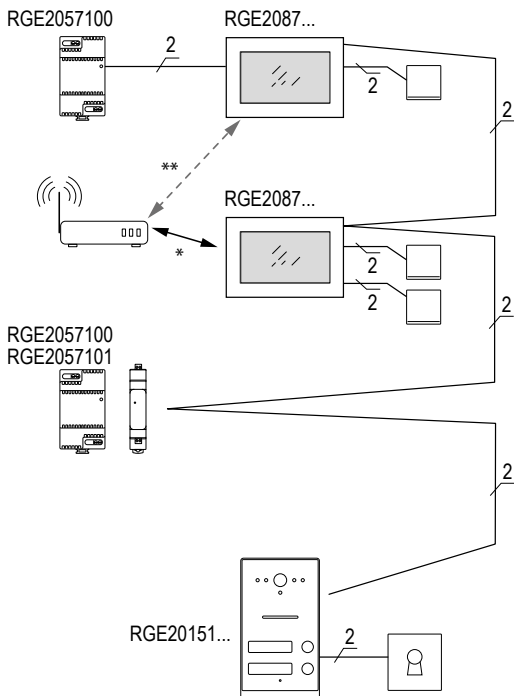

- * The connection of the indoor station with a router enables the use of the TwinBus IP app and the time synchronization with an NTP server.
- ** The optional connection to other video indoor stations is only used for NTP time synchronization on the Internet.

2-family house

Wiring diagram

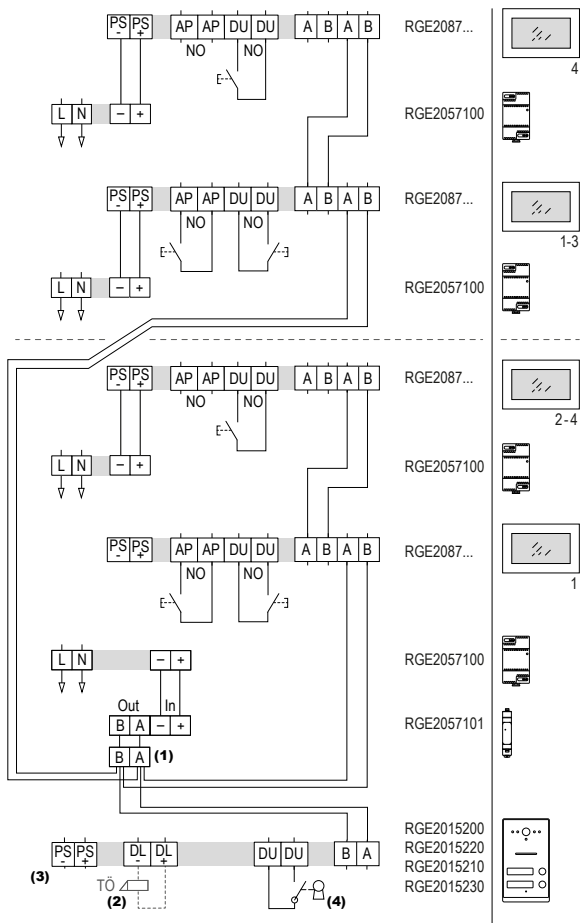

- (1) Terminal strip
- (2) Door opener, DC 6 V ... 12 V, max. 800 mA
- (3) **⚠ WARNING** Danger to life due to electric shock
 - Use only a SELV power supply.

Failure to comply with this instruction may result in death or serious injury.

Connection of an additional power supply (DC 24 V ... 28 V, 2,5 A) if the cable length from the door station to the door opener exceeds 80 m.

- (4) For example, an external card reader
- NO Normally open contacts of the indoor station: Connection of a push-button to unlock the door (DU) and to connect an apartment button ED (AP).
- TÖ Door opener

Power supply of the system:

One REG power supply RGE2057100 can supply the following components:

- REG bus filter, 1 video indoor station and 1 door station with door opener at the A Bus +/B Bus - connection or
- 3 video indoor stations at the PS+/PS- connection

Maximum system configuration:

8x video indoor stations (for each household 4 indoor stations),
1x door station, 1x REG bus filter, 4x REG power supply

Block diagram

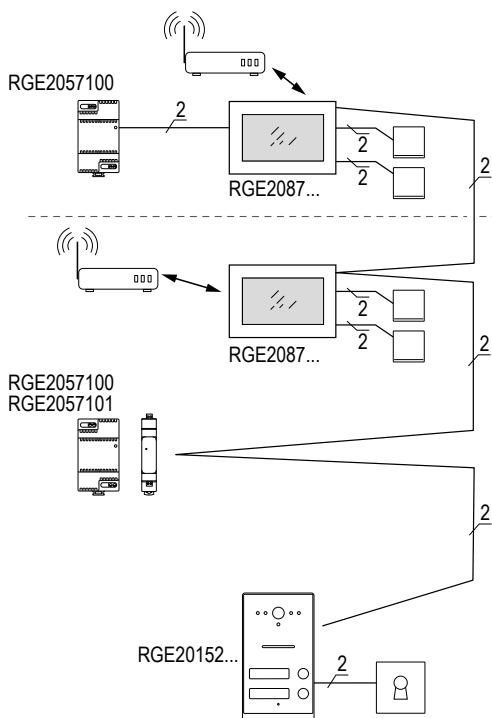

v

For information on connecting the indoor station with a router see [Block diagram --> 18](#) in chapter Single-family house.

Technical data

Input voltage (Bus) SELV DC 24 V

Current consumption <1.2 A

Connection terminal

Clamping range (conductor diameter) 1x 0.5 mm ... 0.8 mm solid
1x AWG 24 ... AWG 20 solid
Copper-clad aluminum conductors must not be used.

Nominal torque 0.2 Nm

Door opener

Rated voltage DC 6 V ... DC 12 V

Current (Bus) max. 800 mA

Door opening time 1 s ... 5 s (factory setting 3 s)

Camera

Resolution 1.3 megapixels

Angle of detection 120° horizontal, 78° vertical

Lighting for name plates and call buttons

Brightness threshold < 20 lux

Colour lighting White

Environmental conditions

Ambient temperature -20 °C ... 55 °C

Humidity (max) 96 %

Dimensions and weights

Installation height 1.6 m

Dimensions for surface mount variant (LxBxH) 180 x 101 x 28.4 mm

Dimensions for flush mount variant (LxBxH) 207.5 x 125 x 48 mm

Dimensions for wall box (LxBxH) 201 x 118 x 43 mm

Weight flush mount variant	537 g
Weight wall mount variant	440 g
Weight wall box	268 g
Protection class	IP55

WEEE



Dispose of the device separately from household waste at an official collection point. Professional recycling protects people and the environment against potential negative effects.

Schneider Electric GmbH

Fritz-Kotz-Str. 8

51674 Wiehl

Germany

se.com/contact

© 2023 Schneider Electric, all rights reserved

NNZ42644-02 2023/01