

7392 kW, Tier III, NAM, Chilled Water, Liquid-Cooled AI Clusters

Design Overview

Data Center IT Capacity
7392 kW

Target Availability
Tier III

Annualized PUE at 100% Load
San Francisco, CA: 1.14
Dallas, TX: 1.17

Racks and Density
Total Racks: 96
Rack Power Density:
Networking racks up to 22 kW/rack
AI racks up to 132 kW/rack

Data Center Overall Space
37,774 ft²

Regional Voltage and Frequency
480V, 60Hz

About this Design

- IT space and power distribution designed to accommodate AI clusters with density up to 132 kW per rack
- Design optimized to support liquid-cooled racks, with liquid-to-liquid coolant distribution units (CDUs) and fluid coolers with adiabatic assist
- Chilled water systems optimized for high water temperatures using *Uniflair FWCV* fan walls and *Uniflair XRAF* air-cooled packaged chillers
- Redundant design for increased availability and concurrent maintainability

Introduction

High-density AI clusters and liquid cooling bring new challenges to data center design. Schneider Electric's data center reference designs help shorten the planning process by providing validated, proven, and documented data center physical infrastructure designs to address such challenges. This design focuses on the deployment of high-density AI clusters, specifically *NVIDIA's GB200 NVL72* racks, in a single IT room. The IT room is purpose-built and optimized for three *NVIDIA 1152 GPU DGX SuperPOD GB200* clusters using liquid-to-liquid CDUs and fluid coolers with adiabatic assist. Facility power and cooling design are optimized for capital cost, efficiency, and reliability.

Reference Design 109 includes information on four technical areas: facility power, facility cooling, IT space and lifecycle software. These areas represent the integrated systems required to meet the design's specifications provided in this overview document.

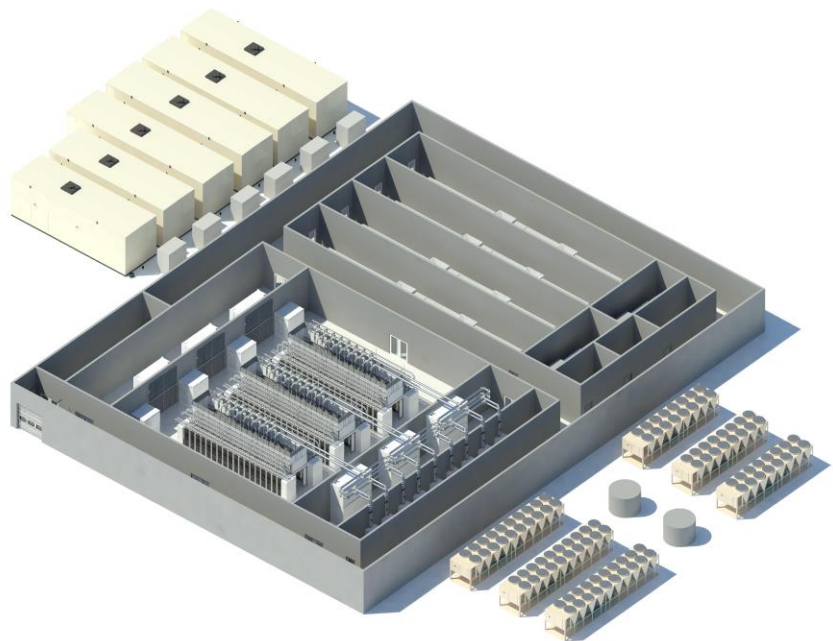

Facility Power

Facility Power Block Diagram

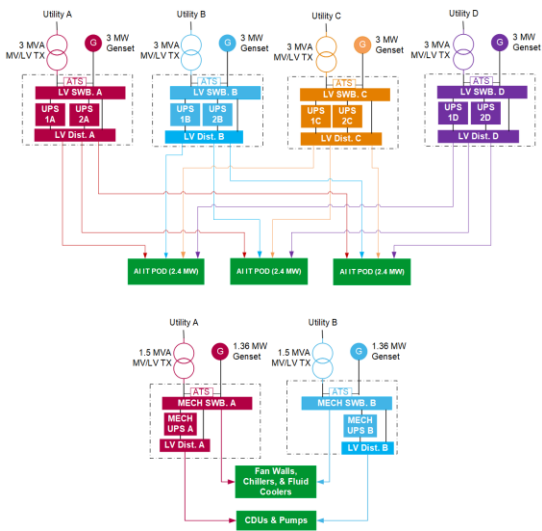

The facility power system supplies power to all components within the data center. In this concurrently maintainable electrical design, power to the IT rooms is supplied through four 3 MW powertrains. The four powertrains provide 3+1 distributed redundant UPS power to the IT space, backed up by diesel generators. Each powertrain consists of a 4000-amp QED-2 main switchboard feeding two 1500 kW Galaxy VX UPS with 5 minutes of runtime in parallel and a 4000-amp QED-2 distribution section. Downstream, these powertrains feed Hyper 1.3 MVA 480V:415V/240V power distribution units (PDUs), that power the IT racks with 3+1 redundancy. Separately, two 1.5 MW powertrains feed the fan walls, chillers, and fluid coolers with 2N redundant power. They also feed a 250 kW Galaxy VL UPS that provides critical power to the liquid-to-liquid coolant distribution units (CDUs) and facility water system pumps.

The facility power system is designed to support integrated peripheral devices like fire panels, access control systems, and environmental monitoring and control devices. Power meters in the electrical path monitor power quality and allow for predictive maintenance & diagnostics of the system. These meters also integrate with EcoStruxure Power Monitoring Expert.

Every component in this design is built and tested to the applicable IEEE or UL standards.

Further design details, such as dimensions, schematics, and equipment lists are available in the engineering package.

Design Options

This reference design can be modified as follows without a significant effect on the design’s performance attributes:

- Provision for load bank
- Change UPS battery type & runtime
- Add/remove/change standby generators:
 - Location & tank size

Facility Power Attributes

Name	Value	Unit
Total facility peak power (IT and cooling)	10,500	kW
Total amps (IT main bus, each)	4000	A
Input voltage (IT main bus)	480	V
Switchboard kAIC (IT main bus)	65	kA
Generator redundancy (IT main bus)	Distributed redundant	
IT power path	3+1	
IT space UPS capacity, per powertrain	3000	kW
IT space UPS redundancy	Distributed redundant	
IT space UPS runtime @ rated load	5	minutes
IT space UPS output voltage	480	V
Total amps (Facility cooling bus, each)	1600	A
Input voltage (Facility cooling bus)	480	V
Switchboard kAIC (Facility cooling bus)	35	kA
Generator redundancy (Facility cooling bus)	2N	
Facility cooling UPS capacity	250	kW
Facility cooling UPS redundancy	2N	
Facility cooling UPS runtime @ rated load	5	minutes

Facility Cooling

Facility Cooling Block Diagrams

Facility Water System Flow

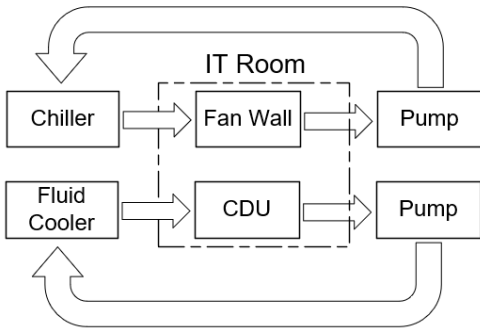

Facility Piping Diagram

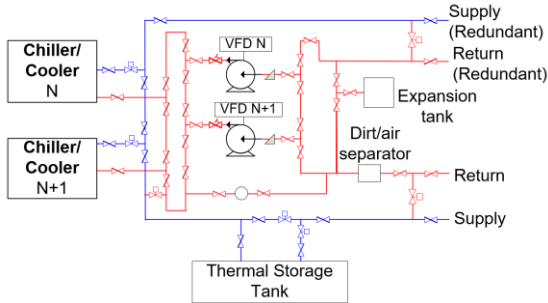

Similar piping architecture for chilled water loop and fluid cooler loop

Design Options

This reference design can be modified as follows without a significant effect on the design's performance attributes:

- Change storage tank size
- Integrate heat exchanger on FWS with additional *Uniflair XRAF* chillers to enable 100% dry cooling

The facility cooling design features a dual path piping system optimized for data center efficiency. A chilled water loop integrates *Uniflair XRAF* chillers, with free cooling capabilities, to deliver 73°F chilled water to fan walls in N+1 configuration. This lower temperature water loop is required to handle air cooling needs of the data center. A separate high temperature water loop supplies 99°F water to liquid-to-liquid CDUs used to cool *NVIDIA's GB200 NVL72* liquid cooled racks. Outdoor heat rejection for this loop is supported by *Guntner GFD V-Shape Vario* fluid coolers. With supply water temperatures approaching 100°F, fluid coolers are useful heat rejection units in a wide range of climates. Using fluid cooler based cooling provides large energy and capex savings compared to chillers. For ambient temperatures above 90°F, the fluid coolers use adiabatic assist to provide sufficient cooling for the data center.

An integrated thermal storage system provides 5 minutes of continuous cooling, in case of power outage, to allow the chillers and fluid coolers to restart. The CDUs and facility pumps are on UPS power. More information on fan wall and CDU cooling architecture is detailed in the IT room section of this document.

This design is instrumented to work with *EcoStruxure IT Expert* and *AVEVA Unified Operations Center*.

Further design details such as dimensions, schematics, and equipment lists are available in the engineering package.

Facility Cooling Attributes

Name	Value	Unit
Total max cooling capacity	9051 (Dallas) 9369 (San Francisco)	kW
Input voltage	480	V
Heat rejection medium	Water	
Chiller redundancy	N+1	
Outdoor heat exchange	Fluid cooler with adiabatic assist & packaged chiller	
Chiller CW supply temperature	73	°F
Chiller CW return temperature	91	°F
Fluid cooler CW supply temperature	99	°F
Fluid cooler CW return temperature	117	°F
Combined* storage tank size	15,002	gallon
Ride-through time	5	minutes
Outdoor ambient temperature range	11.1 to 110.5	°F
Economizer type	Water-side	

*Summation of both facility water systems

IT Room

IT Room Diagrams

IT Room Layout

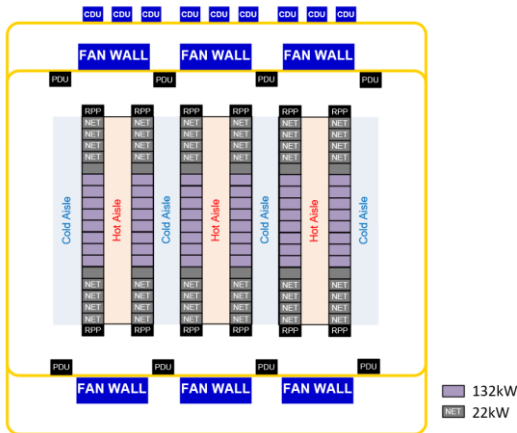

IT Room Piping

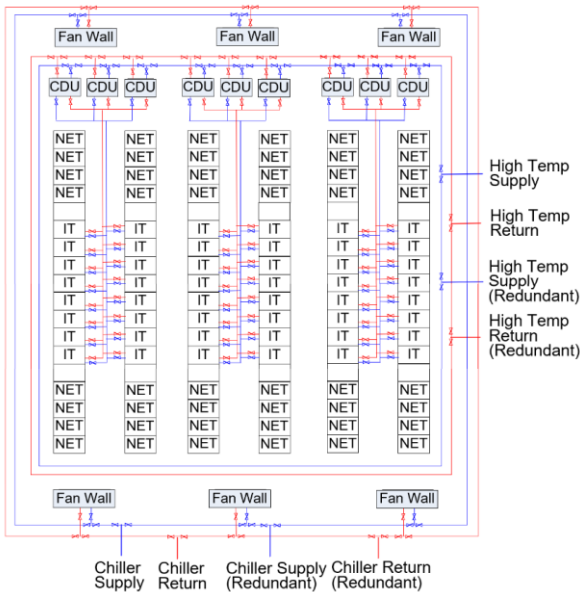

Design Options

This reference design can be modified as follows without a significant effect on the design's performance attributes:

- Use *Uniflair FXCV* fan walls
- CRAHs can be selected instead of fan walls
- Variations in AI cluster configuration

The IT room features forty-eight 132 kW liquid cooled IT racks, modeled after *NVIDIA's GB200 NVL72*, with forty-eight 22 kW air-cooled networking racks. The 132 kW IT racks are configured in pods of 16 racks with 8 racks together in each row. The liquid cooled racks remove 87% of the heat via liquid while 13% requires air. Four 22 kW networking racks are placed on both ends of the row accompanied by one empty rack incase additional rack space is required. The racks share a 6 ft. wide hot aisle to allow for proper airflow. Ducted hot aisles and a common ceiling plenum return hot air to the fan walls for cooling.

Six *Uniflair FWCV* chilled water fan walls supply conditioned air to the IT room in an N+1 configuration. The redundant piping system across the IT room provides an alternate path for chilled water in case of cooling equipment failure or maintenance.

The 22 kW networking racks are configured with 1+1 60 A *NetShelter Rack PDU Advanced* rack-mount power distribution units (rPDUs). The 132 kW AI racks are configured with 6+2 33 kW OCP-like power shelves. Each row is powered by four *Hyper 1300 kVA PDUs* and two *Hyper High Density 2x800 A RPPs*, providing A-, B-, C-, and D-side power to the row. The 132 kW AI racks have a pair of 60 A feeds coming from each of the 800 A panel in the RPPs, for a total of eight power feeds per rack from the RPPs – one for each power shelf. The 22 kW networking racks have a pair of 60 A feeds from two of the four 800 A RPPs for 2N redundant feeds. The *Hyper High Density 2x800A RPP* includes *PowerLogic HDPM* for branch circuit power monitoring, *PowerLogic ION900T* for metering each 800 A RPP with transient capture, and *PowerPacT B-Frame* circuit breakers that can be configured with shunt trip units for those feeding liquid cooled racks.

IT Room Attributes

Name	Value	Unit
IT load	7392	kW
Supply voltage to IT	415	V
Rack power feed redundancy	Redundant	
Number of 132 kW liquid-cooled racks	48	racks
Number of 22 kW networking racks	48	racks
IT floor space	5486	ft ²
CRAC/CRAH type	Fan wall	
CRAC/CRAH redundancy	N+1	
CW supply temperature	73	°F
CW return temperature	91	°F
Containment type	Ducted hot aisle	
CDU type	L2L	
CDU redundancy	N+1	
CDU CW supply temperature	99	°F
CDU CW return temperature	117	°F
TCS loop supply temperature	104	°F
TCS loop return temperature	129	°F

Lifecycle Software

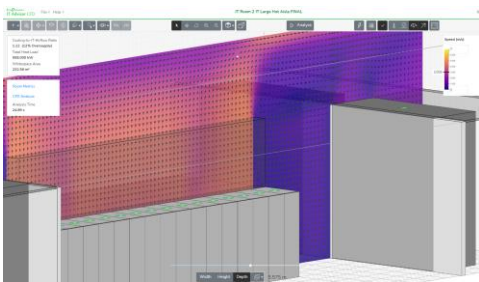
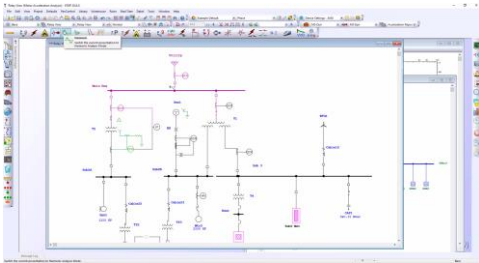

High-density AI clusters push the limits of data center facility infrastructure, so it's critical to leverage advanced planning and operation tools to ensure safe and reliable operations.

Planning & Design

Electrical Safety and Reliability: Due to the high amount of power supplied to an AI cluster, design specifications such as available fault current, arc flash hazards and breaker selectivity must be analyzed in the design phase. Applications like *Ecodial* and *ETAP* simulate the electrical design and reduce the chance of costly mistakes or even worse, injury.

Cooling: AI clusters are pushing the limits of what can be done with air-cooling. Modeling the IT space with computational fluid dynamics (CFD) helps spot issues including high pressure areas, rack recirculation, and hot spots. This is especially true when retrofitting an existing data center with an AI cluster. Schneider Electric's *EcoStruxure IT Design CFD* can quickly model airflow, allowing rapid iteration to find the best design and layout.

Operations

EcoStruxure™ is Schneider Electric's open, interoperable, integrated Internet of Things (IOT)-enabled system architecture and platform. It consists of three layers: connected products, edge control, and applications, analytics, and services.

EcoStruxure Data Center is a combination of three domains of *EcoStruxure*: Power, Building, and IT. Each domain is focused on a subsystem of the data center: power, cooling, and IT. These three domains combined will reduce risks, increase efficiencies, and speed operations across the entire facility.

- *EcoStruxure Power* monitors power quality, generates alerts, while protecting and controlling the electrical distribution the electrical distribution system of the data center from the MV level to the LV level. It uses any device for monitoring and alerting, uses predictive analytics for increased safety, availability, and efficiency, while lowering maintenance costs.
- *EcoStruxure Building* controls cooling effectively while driving reliability, efficiency, and safety of building management, security, and fire systems. It performs data analytics on assets, energy use, and operational performance.
- *EcoStruxure IT* makes IT infrastructure more reliable and efficient while simplifying management by offering complete visibility, alerting and modelling tools. It receives data, generates alerts, predictive analytics, and system advice on any device to optimize availability and efficiency in the IT space.

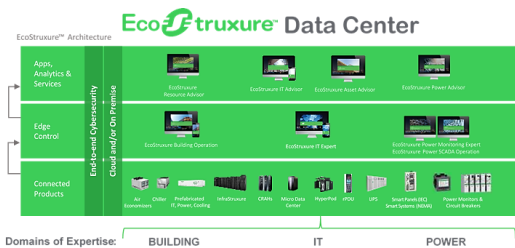

Visit [EcoStruxure for Data Center](#) for more details.

There are several options for supervisory visibility and control. *AVEVA Unified Operations Center* can provide visibility at a site or across an entire enterprise.

Design Attributes

OVERVIEW	Value	Unit
Target availability	III	Tier
Annualized PUE at 100% load	1.14	San Francisco, CA
	1.17	Dallas, TX
Data center IT capacity	7392	kW
Data center overall space	37,774	ft ²
Maximum rack power density	132	kW/rack
FACILITY POWER	Value	Unit
Total facility peak power (IT and cooling)	10500	kW
Total amps (IT main bus, each)	4000	A
Input voltage (IT main bus)	480	V
Switchboard kAIC	65	kA
Generator redundancy (IT main bus)	Distributed redundant	
IT Power path	3+1	
IT space UPS capacity, per powertrain	3000	kW
IT space UPS redundancy	Distributed redundant	
IT space UPS runtime @ rated load	5	minutes
IT space UPS output voltage	480	V
Total amps (facility cooling bus, each)	1600	A
Input voltage (facility cooling bus)	480	V
Switchboard kAIC (facility cooling bus)	35	kA
Generator redundancy (facility cooling bus)	2N	
FACILITY COOLING	Value	Unit
Total max cooling capacity	9051 (Dallas), 9369 (San Francisco)	kW
Input voltage	480	V
Heat rejection medium	Water	
Chiller redundancy	N+1	
Outdoor heat exchange	Fluid cooler with adiabatic assist & packaged chiller	
Chiller CW supply temperature	73	°F
Chiller CW return temperature	91	°F
Fluid cooler CW supply temperature	99	°F
Fluid cooler CW return temperature	117	°F
Combined* storage tank size	15,002	gallon
Ride-through time	5	minutes
Outdoor ambient temperature range	11.1 to 110.5	°F
Economizer type	Water-side	

*Summation of both facility water systems

Design Attributes continued

IT SPACE	Value	Unit
IT load	7392	kW
Supply voltage to IT	415	V
Maximum rack power density	132	kW/rack
Number of racks	96	racks
IT floor space	5486	ft ²
Rack power feed redundancy	Redundant	
CRAC/CRAH redundancy	N+1	
Containment type	Ducted hot aisle	
CDU Type	L2L	
CDU redundancy	N+1	
CW supply temperature	73	°F
CW return temperature	91	°F
CDU CW supply temperature	99	°F
CDU CW return temperature	117	°F
TCS loop supply temperature	104	°F
TCS loop return supply temperature	129	°F

Schneider Electric Life-Cycle Services

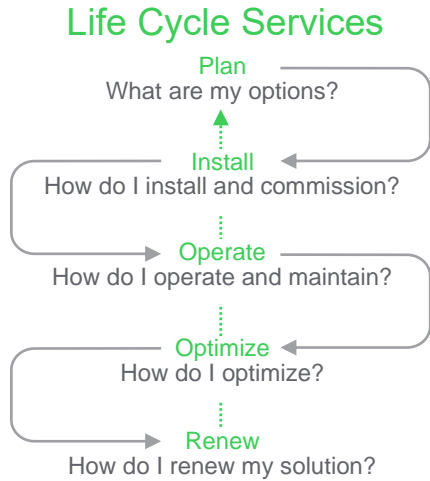

- 1** Team of **over 7,000 trained specialists** covering every phase and system in the data center
- 2** Standardized, documented, and validated **methodology** leveraging automation tools and repeatable processes developed **over 45 years**
- 3** **Complete portfolio of services** to solve your technical or business challenge, simplify your life, and reduce costs

Get more information for this design:

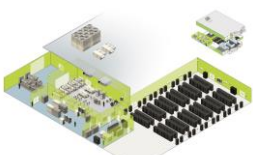

3D spatial views



Floor layouts

Engineering Package

Every reference design is built with technical documentation for engineers and project managers. This includes engineering schematics (CAD, PDF), floor layouts, equipment lists containing all the components used in the design and 3D images showing real world illustrations of our reference designs.

Documentation is available in multiple formats to suit the needs of both engineers and managers working on data center projects. The engineering package of this design can be downloaded [here](#).

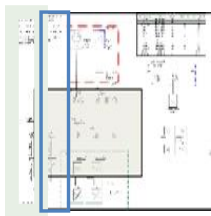

One-line schematics



Bill of materials

Click [here](#) to download the Engineering Package

Email referencedesigns@se.com for further assistance