

Altivar Process ATV6000

Variable Speed Drives

Handbook Manual

QGH83255.05
07/2024



Legal Information

The information provided in this document contains general descriptions, technical characteristics and/or recommendations related to products/solutions.

This document is not intended as a substitute for a detailed study or operational and site-specific development or schematic plan. It is not to be used for determining suitability or reliability of the products/solutions for specific user applications. It is the duty of any such user to perform or have any professional expert of its choice (integrator, specifier or the like) perform the appropriate and comprehensive risk analysis, evaluation and testing of the products/solutions with respect to the relevant specific application or use thereof.

The Schneider Electric brand and any trademarks of Schneider Electric SE and its subsidiaries referred to in this document are the property of Schneider Electric SE or its subsidiaries. All other brands may be trademarks of their respective owner.

This document and its content are protected under applicable copyright laws and provided for informative use only. No part of this document may be reproduced or transmitted in any form or by any means (electronic, mechanical, photocopying, recording, or otherwise), for any purpose, without the prior written permission of Schneider Electric.

Schneider Electric does not grant any right or license for commercial use of the document or its content, except for a non-exclusive and personal license to consult it on an "as is" basis.

Schneider Electric reserves the right to make changes or updates with respect to or in the content of this document or the format thereof, at any time without notice.

To the extent permitted by applicable law, no responsibility or liability is assumed by Schneider Electric and its subsidiaries for any errors or omissions in the informational content of this document, as well as any non-intended use or misuse of the content thereof.

Table of Contents

Safety Information.....	7
Qualification Of Personnel.....	7
Intended Use.....	8
Product Related Information.....	8
About the Book.....	12
Drive System.....	15
Presentation.....	18
ATV6000 - Your smart connected drive.....	18
Benefits.....	19
Application.....	22
Standards and regulations.....	26
Drive topology.....	27
Device basic information.....	28
Control features.....	29
Key functions.....	30
Selection and ordering data.....	31
Type designation.....	31
Selection and ordering data.....	32
General Specification.....	44
High Altitude.....	46
Master Controller Identification.....	47
ATV6000 Drive System I/O Interface Diagram.....	48
With Power Output Enable (POE) Configuration.....	48
With Safe Torque Off (STO) Configuration.....	49
Technical Data.....	50
Output Voltage 2.4 kV.....	50
ATV6000D200A2424...ATV6000D430A2424.....	50
ATV6000D570A2424, ATV6000D650A2424.....	52
ATV6000D790A2424, ATV6000D950A2424.....	53
ATV6000C122A2424.....	54
ATV6000C139A2424...ATV6000C178A2424.....	55
ATV6000C200A2424, ATV6000C213A2424.....	57
ATV6000C225A2424...ATV6000C434A2424.....	58
Layout Drawing and Dimensions.....	62
Output Voltage 3.3 kV.....	67
ATV6000D390A3333...ATV6000D590A3333.....	67
ATV6000D700A3333...ATV6000D890A3333.....	69
ATV6000C100A3333...ATV6000C132A3333.....	71
ATV6000C150A3333...ATV6000C167A3333.....	73
ATV6000C190A3333...ATV6000C244A3333.....	74
ATV6000C293A3333.....	76
ATV6000C328A3333...ATV6000C463A3333.....	77
ATV6000C508A3333.....	80
ATV6000C550A3333...ATV6000C600A3333.....	81
Layout Drawing and Dimensions.....	82
Output Voltage 4.16 kV.....	87
ATV6000D350A4242...ATV6000D750A4242.....	87

ATV6000D890A4242	90
ATV6000C100A4242...ATV6000C113A4242.....	91
ATV6000C125A4242...ATV6000C165A4242	92
ATV6000C188A4242...ATV6000C210A4242	94
ATV6000C240A4242...ATV6000C275A4242	95
ATV6000C308A4242	96
ATV6000C338A4242...ATV6000C369A4242	97
ATV6000C414A4242...ATV6000C542A4242	98
ATV6000C600A4242...ATV6000C753A4242	100
Layout Drawing and Dimensions	102
Output Voltage 5.5 kV	107
ATV6000D450A5555...ATV6000D890A5555	107
ATV6000D990A5555	110
ATV6000C113A5555...ATV6000C132A5555.....	111
ATV6000C149A5555	112
ATV6000C169A5555...ATV6000C278A5555	113
ATV6000C318A5555...ATV6000C408A5555	116
ATV6000C488A5555	118
ATV6000C538A5555	119
ATV6000C600A5555, ATV6000C663A5555	120
ATV6000C717A5555...ATV6000M100A5555	121
Layout Drawing and Dimensions	124
Output Voltage 6 kV	129
ATV6000D450A6060...ATV6000D890A6060	129
ATV6000C108A6060	132
ATV6000C125A6060...ATV6000C138A6060	133
ATV6000C163A6060	134
ATV6000C188A6060...ATV6000C239A6060	135
ATV6000C263A6060...ATV6000C304A6060	137
ATV6000C348A6060...ATV6000C375A6060	138
ATV6000C413A6060...ATV6000C532A6060	139
ATV6000C588A6060	141
ATV6000C638A6060...ATV6000C688A6060	142
ATV6000C782A6060...ATV6000M109A6060	143
Layout Drawing and Dimensions	146
Output Voltage 6.3 kV	151
ATV6000D450A6363...ATV6000D790A6363	151
ATV6000D890A6363, ATV6000C114A6363.....	154
ATV6000C132A6363	155
ATV6000C150A6363	156
ATV6000C170A6363	157
ATV6000C194A6363, ATV6000C228A6363	158
ATV6000C250A6363...ATV6000C282A6363	159
ATV6000C319A6363	160
ATV6000C364A6363	161
ATV6000C413A6363...ATV6000C513A6363	162
ATV6000C558A6363	164
ATV6000C627A6363...ATV6000C688A6363	165
ATV6000C750A6363...ATV6000M114A6363	166
Layout Drawing and Dimensions	169
Output Voltage 6.6 kV	174

ATV6000D450A6666...ATV6000D890A6666	174
ATV6000C100A6666	177
ATV6000C119A6666.....	178
ATV6000C138A6666	179
ATV6000C163A6666	180
ATV6000C179A6666	181
ATV6000C200A6666...ATV6000C225A6666	182
ATV6000C263A6666...ATV6000C288A6666	183
ATV6000C334A6666	184
ATV6000C382A6666...ATV6000C538A6666	185
ATV6000C585A6666	187
ATV6000C657A6666...ATV6000C713A6666	188
ATV6000C775A6666...ATV6000M120A6666	189
Layout Drawing and Dimensions	192
Output Voltage 10 kV	197
ATV6000D450A1010...ATV6000D790A1010	197
ATV6000D890A1010...ATV6000C138A1010	200
ATV6000C150A1010...ATV6000C180A1010	202
ATV6000C200A1010...ATV6000C225A1010	203
ATV6000C272A1010	204
ATV6000C300A1010...ATV6000C350A1010	205
ATV6000C398A1010...ATV6000C438A1010	207
ATV6000C507A1010	208
ATV6000C538A1010...ATV6000C625A1010	209
ATV6000C742A1010...ATV6000C887A1010	211
ATV6000C995A1010...ATV6000M107A1010	213
ATV6000M115A1010	214
ATV6000M131A1010...ATV6000M154A1010.....	215
Layout Drawing and Dimensions	218
Output Voltage 11 kV	223
ATV6000D500A1111...ATV6000D690A1111	223
ATV6000D790A1111...ATV6000C199A1111	225
ATV6000C225A1111	228
ATV6000C250A1111...ATV6000C298A1111	229
ATV6000C325A1111...ATV6000C375A1111	230
ATV6000C438A1111	231
ATV6000C557A1111	232
ATV6000C637A1111...ATV6000C975A1111	233
ATV6000M110A1111	236
ATV6000M125A1111...ATV6000M144A1111	237
ATV6000M159A1111...ATV6000M188A1111	238
Layout Drawing and Dimensions	240
Options	245
Available Options	245
Communication Buses and Networks	248
I/O Extension Modules	250
Encoder Interface Modules.....	251
Output Filters	252
Power Supply.....	253
Wiring.....	254
Safety Function or Power Output Enable function.....	256

Environment and General Technical Data	258
Cabinet and Transformer.....	259
Harsh Environment.....	260
Guarding Options	262
Customization	266

Safety Information

Important Information

Read these instructions carefully, and look at the equipment to become familiar with the device before trying to install, operate, service, or maintain it. The following special messages may appear throughout this documentation or on the equipment to warn of potential hazards or to call attention to information that clarifies or simplifies a procedure.



The addition of this symbol to a "Danger" or "Warning" safety label indicates that an electrical hazard exists which will result in personal injury if the instructions are not followed.



This is the safety alert symbol. It is used to alert you to potential personal injury hazards. Obey all safety messages that follow this symbol to avoid possible injury or death.

⚠ DANGER
DANGER indicates a hazardous situation which, if not avoided, will result in death or serious injury.

⚠ WARNING
WARNING indicates a hazardous situation which, if not avoided, could result in death or serious injury.

⚠ CAUTION
CAUTION indicates a hazardous situation which, if not avoided, could result in minor or moderate injury.

NOTICE
NOTICE is used to address practices not related to physical injury.

Please Note

Electrical equipment should be installed, operated, serviced, and maintained only by qualified personnel. No responsibility is assumed by Schneider Electric for any consequences arising out of the use of this material.

A qualified person is one who has skills and knowledge related to the construction and operation of electrical equipment and its installation, and has received safety training to recognize and avoid the hazards involved.

Qualification Of Personnel

Only appropriately trained persons who are familiar with and understand the contents of this manual and all other pertinent product documentation are authorized to work on and with this product. In addition, these persons must have received safety training to recognize and avoid hazards involved. These persons must have sufficient technical training, knowledge and experience and be able to foresee and detect potential hazards that may be caused by using the product, by changing the settings and by the mechanical, electrical and electronic equipment

of the entire system in which the product is used. All persons working on and with the product must be fully familiar with all applicable standards, directives, and accident prevention regulations when performing such work.

Intended Use

This product is a drive for three-phase synchronous, asynchronous motors and intended for industrial use according to this manual.

The product may only be used in compliance with all applicable safety standard and local regulations and directives, the specified requirements and the technical data. The product must be installed outside the hazardous ATEX zone. Prior to using the product, you must perform a risk assessment in view of the planned application. Based on the results, the appropriate safety measures must be implemented. Since the product is used as a component in an entire system, you must ensure the safety of persons by means of the design of this entire system (for example, machine design). Any use other than the use explicitly permitted is prohibited and can result in hazards.

Product Related Information

Read and understand these instructions before performing any procedure with this drive.

DANGER

HAZARD OF ELECTRIC SHOCK, EXPLOSION OR ARC FLASH

Before performing work on the drive system:

- Follow the instructions given in the section "Complete drive system power Off procedure" of the installation manual.

Before applying voltage to the drive system:

- Verify that the work has been completed and that the entire installation cannot cause hazards.
- Remove the ground and the short circuits on the mains input terminals and the motor output terminals.
- Verify proper grounding of all equipment.
- Verify that all protective equipment such as covers, doors, grids is installed and/or closed.

Failure to follow these instructions will result in death or serious injury.

⚠ ⚠ DANGER**HAZARD OF ELECTRIC SHOCK, EXPLOSION OR ARC FLASH**

- Only appropriately trained persons who are familiar with and fully understand the contents of the present manual and all other pertinent product documentation and who have received all necessary training to recognize and avoid hazards involved are authorized to work on and with this drive system.
- Installation, adjustment, repair and maintenance must be performed by qualified personnel.
- Verify compliance with all local and national electrical code requirements as well as all other applicable regulations with respect to grounding of all equipment.
- Only use properly rated, electrically insulated tools and measuring equipment.
- Do not touch unshielded components or terminals with voltage present.
- Prior to performing any type of work on the drive system, block the motor shaft to prevent rotation.
- Insulate both ends of unused conductors of the motor cable
- Do not create short circuits across the DC bus terminals or the DC bus capacitors.

Failure to follow these instructions will result in death or serious injury.

Damaged products or accessories may cause electric shock or unanticipated equipment operation.

⚠ ⚠ DANGER**ELECTRIC SHOCK OR UNANTICIPATED EQUIPMENT OPERATION**

Do not use damaged products or accessories.

Failure to follow these instructions will result in death or serious injury.

Contact your local Schneider Electric sales office if you detect any damage whatsoever.

This equipment has been designed to operate outside of any hazardous location. Only install this equipment in zones known to be free of a hazardous atmosphere.

⚠ DANGER**POTENTIAL FOR EXPLOSION**

Install and use this equipment in non-hazardous locations only.

Failure to follow these instructions will result in death or serious injury.

Your application consists of a whole range of different interrelated mechanical, electrical, and electronic components, the drive being just one part of the application. The drive by itself is neither intended to nor capable of providing the entire functionality to meet all safety-related requirements that apply to your application. Depending on the application and the corresponding risk assessment to be conducted by you, a whole variety of additional equipment is required such as, but not limited to, external encoders, external brakes, external monitoring devices, guards, etc.

As a designer/manufacture of machines, you must be familiar with and observe all standards that apply to your machine. You must conduct a risk assessment and determine the appropriate Performance Level (PL) and/or Safety Integrity Level (SIL) and design and build your machine in compliance with all applicable standards. In doing so, you must consider the interrelation of all components of the machine. In addition, you must provide instructions for use that enable the user of your machine to perform any type of work on and with the machine such as operation and maintenance in a safe manner.

The present document assumes that you are fully aware of all normative standards and requirements that apply to your application. Since the drive cannot provide all safety-related functionality for your entire application, you must ensure that the required Performance Level and/or Safety Integrity Level is reached by installing all necessary additional equipment.

⚠ WARNING

INSUFFICIENT PERFORMANCE LEVEL/SAFETY INTEGRITY LEVEL AND/OR UNINTENDED EQUIPMENT OPERATION

- Conduct a risk assessment according to EN ISO 12100 and all other standards that apply to your application.
- Use redundant components and/or control paths for all critical control functions identified in your risk assessment.
- Implement all monitoring functions required to avoid any type of hazard identified in your risk assessment, for example, slipping or falling loads.
- Verify that the service life of all individual components used in your application is sufficient for the intended service life of your overall application.
- Perform extensive commissioning tests for all potential error situations to verify the effectiveness of the safety-related functions and monitoring functions implemented, for example, but not limited to, speed monitoring by means of encoders, short circuit monitoring for all connected equipment, correct operation of brakes and guards.
- Perform extensive commissioning tests for all potential error situations to verify that the load can be brought to a safe stop under all conditions.

Failure to follow these instructions can result in death, serious injury, or equipment damage.

Product may perform unexpected movements because of incorrect wiring, incorrect settings, incorrect data or other errors.

⚠ WARNING

UNANTICIPATED EQUIPMENT OPERATION

- Carefully install the wiring in accordance with the EMC requirements.
- Do not operate the product with unknown or unsuitable settings or data.
- Perform a comprehensive commissioning test.

Failure to follow these instructions can result in death, serious injury, or equipment damage.

▲ WARNING
<p>LOSS OF CONTROL</p> <ul style="list-style-type: none"> • The designer of any control scheme must consider the potential failure modes of control paths and, for critical control functions, provide a means to achieve a safe state during and after a path failure. Examples of critical control functions are emergency stop, overtravel stop, power outage and restart. • Separate or redundant control paths must be provided for critical control functions. • System control paths may include communication links. Consideration must be given to the implications of unanticipated transmission delays or failures of the link. • Observe all accident prevention regulations and local safety guidelines (1). • Each implementation of the product must be individually and thoroughly tested for proper operation before being placed into service. <p>Failure to follow these instructions can result in death, serious injury, or equipment damage.</p>

(1) For USA: Additional information, refer to NEMA ICS 1.1 (latest edition), Safety Guidelines for the Application, Installation, and Maintenance of Solid State Control and to NEMA ICS 7.1 (latest edition), Safety Standards for Construction and Guide for Selection, Installation and Operation of Adjustable-Speed Drive Systems.

▲ WARNING
<p>LOSS OF CONTROL</p> <p>Perform a comprehensive commissioning test to verify that communication monitoring properly detects communication interruptions</p> <p>Failure to follow these instructions can result in death, serious injury, or equipment damage.</p>

NOTICE
<p>DESTRUCTION DUE TO INCORRECT MAINS VOLTAGE</p> <p>Before switching on and configuring the product, verify that it is approved for the mains voltage.</p> <p>Failure to follow these instructions can result in equipment damage.</p>

About the Book

Document Scope

This document gives you an overview of the available Altivar Process Drive Systems.

Furthermore, you can select from the options described in detail in order to adapt the Altivar Process Drive System to the actual requirements of your system.

Validity Note

The information in this manual is merely informative and maybe subject to modification.

Original instructions and information given in this manual have been written in English (before optional translation).

All pictures shown are for 3D illustration purpose only. Depending on the product chosen, product layout may vary.

This documentation is valid for the Altivar Process ATV6000 Medium Voltage Drives.

The asterisks (*) available to this document is linked to the following information: Based on previous data. This is not a guarantee of future performance or performance in your particular circumstances.

The characteristics of the products described in this document are intended to match the characteristics that are available on www.se.com. As part of our corporate strategy for constant improvement, we may revise the content over time to enhance clarity and accuracy. If you see a difference between the characteristics in this document and the characteristics on www.se.com, consider www.se.com to contain the latest information.

Related Documents

Use your tablet or your PC to quickly access detailed and comprehensive information on all our products on www.se.com.

The Internet site provides the information you need for products and solutions:

- The Handbook for detailed characteristics and selection guides,
- The CAD files to help design your installation,
- All software and firmware to maintain your installation up to date,
- Additional documents for better understanding of drive systems and applications
- And finally all the User Guides related to your drive, listed below:

(Other option manuals and Instruction sheets are available on www.se.com)

Title of Documentation	Reference number
Altivar Process range brochure	998-20307132 (English)
Recommended Cybersecurity Best Practices	CS-Best-Practices-2019-340 (English)
ATV6000 Handbook	QGH83255 (English), PHA51119 (French), PHA51121 (German), PHA51120 (Spanish), GDE94089 (Italian), PHA51122 (Russian), PHA51118 (Chinese)
ATV6000 Installation Manual	QGH83258 (English), QGH83259 (French), QGH83261 (German), QGH83260 (Spanish), GDE94087 (Italian), QGH83257 (Chinese)
ATV6000 Programming Manual for Operator and Advanced Operator	QGH83265 (English), QGH83266 (French), QGH83268 (German), QGH83267 (Spanish), GDE94088 (Italian)
ATV6000 Embedded Safety Function Manual	BQT43422 (English)
ATV6000 Communication Parameters	MFR82761 (English)
ATV6000 Embedded Ethernet Manual	PHA30472 (English)
ATV6000 Modbus SL Manual	MFR24213 (English)
ATV6000 PROFIBUS Manual	PHA30474 (English)
ATV6000 DeviceNet Manual	PHA30471 (English)
ATV6000 EtherCat Manual	PHA30473 (English)
ATV6000 Profinet Manual	PHA30475 (English)
ATV6000 CANopen Manual	PHA30470 (English)
SoMove: FDT	SoMove_FDT (English, French, German, Spanish, Italian, Chinese)
Altivar Process ATV6000: DTM	ATV6000 DTM Library EN (English)

You can download these technical publications and other technical information from our website at www.se.com/en/download

Terminology

The technical terms, terminology, and the corresponding descriptions in this manual normally use the terms or definitions in the relevant standards.

In the area of drive systems this includes, but is not limited to, terms such as **error**, **error message**, **failure**, **fault**, **fault reset**, **protection**, **safe state**, **safety function**, **warning**, **warning message**, and so on.

Among others, these standards include:

- IEC 61800 series: Adjustable speed electrical power drive systems
- IEC 61508 Ed.2 series: Functional safety of electrical/electronic/programmable electronic safety-related
- EN 954-1 Safety of machinery - Safety related parts of control systems
- ISO 13849-1 & 2 Safety of machinery - Safety related parts of control systems
- IEC 61158 series: Industrial communication networks - Fieldbus specifications
- IEC 61784 series: Industrial communication networks - Profiles
- IEC 60204-1: Safety of machinery - Electrical equipment of machines – Part 1: General requirements

In addition, the term **zone of operation** is used in conjunction with the description of specific hazards, and is defined as it is for a **hazard zone** or **danger zone** in the EC Machinery Directive (2006/42/EC) and in ISO 12100-1.

Contact Us

Select your country on:

www.se.com/contact

Schneider Electric Industries SAS

Head Office

35, rue Joseph Monier

92500 Rueil-Malmaison

France

Drive System

Overview

Altivar Process - ATV6000

Marketing segment

- Mining, Mineral & Metals
- Water & Wastewater
- Oil & Gas
- Power Generation

Product Picture



Type

ATV6000

Brief description

Medium Voltage Drive System with multi-pulse transformer and low voltage inverter cascade provides a sinusoidal sine wave at both input and output with low THD(i).

Protection degree

IP31 enclosure design
 IP41 enclosure design optional available
 IP42 enclosure design optional available

Power range

160...20,000 kW

Voltage ranges

3.3 kV, 4.16 kV, 6.0 kV, 6.6 kV, 10 kV, 11 kV
 2.4 kV (on request), 13.8 kV (on request)

Mains frequency

50/60 Hz ± 5 %

Output frequency

0.1 to 120 Hz

Controlled motors

- Asynchronous motor
- Synchronous motor
 - PM motor
 - PM motor with starter winding DOL

Application types

- Constant torque
- Variable torque
- Multi motor applications

Control features

- Vector control mode
- Energy efficiency mode
- With or without encoder

Interfaces

10 inch LCD touch screen as operating panel in the enclosure door,
 I/O terminals for digital and analog signals,
 Ethernet dual port connector, supporting Ethernet IP and Modbus TCP,
 Modbus SL connector
 Fieldbus options for Profibus, Profinet, EtherCAT, DeviceNet, CANopen

Further reading

You will find detailed information in this document.

Altivar Process - ATV6xx

Marketing segment

- Water and waste water
- Oil & gas
- Mining, minerals & metals
- Food & beverage

Product Picture



Type	ATV660	ATV680
Brief description	Enclosure unit, alternatively in the standard design, with additionally installed options or as a customized solution (Engineered To Order ETO)	Enclosure unit ready for regeneration, alternatively in the standard design, with predefined customizations or as individual customer solution
Protection degree	IP23 standard design of the enclosure IP54 optional design of the enclosure	
Power range	110 / 90 up to 800 / 630 kW	
Voltage ranges	3AC 380 V -10% - 415 V +6 % (other voltages possible - ETO)	
Mains frequency	50/60 Hz \pm 5 %	
Output frequency	0.1...500 Hz	
Control method	Asynchronous motor: <ul style="list-style-type: none"> • Constant load torque standard, variable load torque standard, load-depending mode Synchronous motor: <ul style="list-style-type: none"> • PM (permanent magnet) motor 	
Interfaces	Operating panel in the enclosure door, control terminals inside the enclosure, control terminals can be extended, fieldbus connection via Ethernet or Modbus, reading of the parameters via USB interface at the keypad	
Further reading	You can find information about project planning and order in the "Configuration guide Altivar Process ATV660" and on on www.se.com .	You can find information about project planning and order in the "Configuration guide Altivar Process ATV680" and on on www.se.com .

Altivar Process - ATV9xx

Marketing segment

- Water and waste water
- Oil & gas
- Mining, minerals & metals
- Food & beverage

Product Picture



Type	ATV960	ATV980
Brief description	Enclosure unit, alternatively in the standard design, with predefined customizations or as individual customer solution	Enclosure unit ready for regeneration, alternatively in the standard design, with predefined customizations or as individual customer solution
Protection degree	IP23 standard design of the enclosure	IP54 optional design of the enclosure
Power range	110 / 90 up to 800 / 630 kW	
Voltage ranges	3AC 380 V -10% - 415 V +6 % (other voltages possible)	
Mains frequency	50/60 Hz ± 5 %	
Output frequency	0.1...500 Hz	
Control method	Asynchronous motor: <ul style="list-style-type: none"> • Constant load torque standard, variable load torque standard, load-depending mode, energy saving mode Synchronous motor: <ul style="list-style-type: none"> • PM (permanent magnet) motor 	
Interfaces	Operating panel in the enclosure door, control terminals inside the enclosure, control terminals can be extended, fieldbus connection via Ethernet or Modbus, saving the parameters via USB interface at the keypad	
Further reading	You can find detailed information in the "Altivar Process ATV960 Handbook" and on www.se.com .	You can find detailed information in the "Altivar Process ATV980 Handbook" and on www.se.com .

Presentation

ATV6000 - Your smart connected drive

The **Altivar™ Process ATV6000** services-oriented drive completes the Altivar Process line-up with a solution to address your medium voltage operation and maintenance challenges.



ATV6000 is a smart, connected product which help optimize your business by:

- Enabling **process optimization**
- Improving **energy management**
- Enhancing **asset management**
- Providing a tailored **engineering solution**

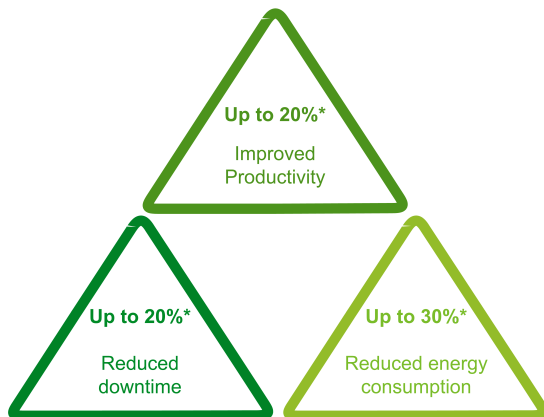

The ATV6000 improves your process performance and asset management capability by transforming data into valuable and actionable business insight.

As a result, you get increased overall equipment effectiveness (OEE) and optimized total cost of ownership (TCO).

- Services-oriented drives for 0 to 20 MW
- Real-time intelligence
- Easy integration in process automation systems
- Intuitive and easy to use
- Optimized performance of applications such as fans, pumps, compressors, and conveyors
- EcoStruxure™-ready

NOTE: *) Based on previous data. This is not a guarantee of future performance or performance in your particular circumstances.

Benefits

Services-oriented drives

Increase availability and reduce Downtime for service continuity by 20%*



Improved operator efficiency

- Generation of robust, actionable, and relevant information
- Advanced communication and predictive maintenance capabilities
- Functionalities for remote intervention and online support
- Easy troubleshooting with QR code
- Comfortable usability with the connected 10" Magelis HMI screen
- Key performance indicators

Fast and easy on-site maintenance operation

- Quicker intervention
- Optimized management of spare parts stock with modular architecture
- Easy front access design

Digital services

More uptime & shorter recovery time with predictive maintenance and reduce TCO by 20%*



- Predictive maintenance, including continuous monitoring, risk assessment, and mitigation plan, with EcoStruxure™ Asset Advisor
- Identification of energy saving potential
- Optimized maintenance budgeting
- 360° diagnostics, with report and analysis
- Records of your crucial assets
- Access to 24/7 Schneider Electric service assistance

EcoStruxure Asset Advisor

Preventive analytics to increase operational performance of your drives systems



ATV6000 provides a unique solution to optimize the operation and maintenance of your installation. It allows you to manage maintenance tasks on your assets with preventive and predictive management based on real-time assessments and predictive analytics. All thanks to the combination of smart connected device technologies and powerful cloud-based risk prediction capabilities.

The ATV6000 with EcoStruxure Asset Advisor transforms data into insight to help run your operations more efficiently and safer, with more availability, and increased profits.

Continuous health monitoring

The operator gets a complete health monitoring view of its assets and conditions of usage (drive, transformer, MCB, motor) and the assets are seen as super-sensors providing relevant data and KPIs.

Risk evaluation

The operator knows in real-time where and what risks are on the installation. Predictive analytics constantly evaluates the level and criticality of risk by looking at an asset, the process duty cycle, and the condition of usage. This enables the ability to predict, in advance, a potential failure or dysfunction of the installation.

Risk mitigation

The operator receives notification of the necessary maintenance task required at the right time to secure the asset and production at minimal cost, mitigating the risks of downtime.

QR code interface

Empowered operator to improve efficiency



The ATV6000 provides a smart and easy to use QR-code interface to provide the operator with relevant drive information. With just one scan of the QR-code with a mobile device (as tablet or smartphone) on the name plate or the HMI screen you get easy access to technical documentation or technical online support for easy error management.

Energy management

Optimize usage of energy and reduce consumption by up to 30%*

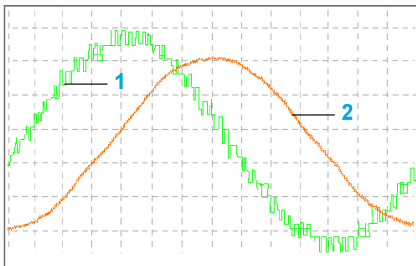

1 Voltage on motor side
2 Current on motor side

Better usage of energy

- Embedded power management with < 5% measurement error
- Key performance indicators and service life monitoring on energy usage
- Smart data collection and access to real-time information

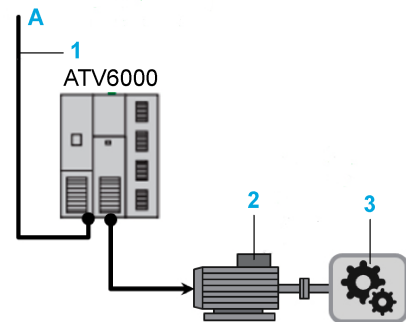

A Mains

- 1 Drive input voltage, Drive input current, Drive input power
- 2 Motor current, Motor voltage, Motor speed, Motor winding & bearing temperature, Consumption kWh
- 3 Over-/Underload, Stall, Cavitation, Flow, Pressure, BEP

Use of clean power

- Designed for seamless integration into installation
- No need to add harmonic mitigation on mains side
- Minimized energy waste
- Reduced motor losses, vibrations, and torque pulses with advanced harmonic-free technology

Process optimization

Improve productivity and availability by up to 20%*

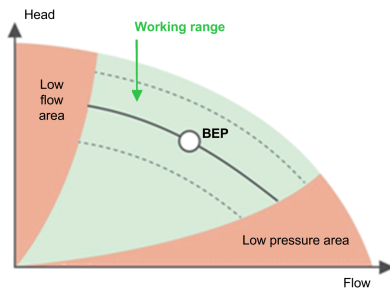

Error tolerant operations

Equipped with level inverter bypass features, ATV6000 help to reduce process interruption.

Proactive maintenance approach

With improved warning functions in case of unusual conditions, and sophisticated measures to help protect equipment against damage. The ATV6000 is also highly modular, enabling fast maintenance operation.

Maximized performance and production output

Ensuring sustainable operation efficiency through making necessary adjustment in case of best efficiency point (BEP) deviation.

BEP Best Efficiency Point Function

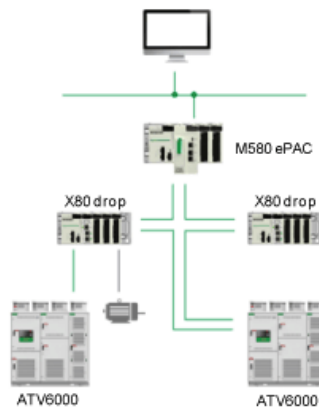

Our IIoT-enabled EcoStruxure solution

Provides compatibility with Process Expert System (PES) architectures, Modicon M580 controllers, and Foxboro EVO DCS systems.

The ATV6000's smart drive capabilities offer innovative features based on IIoT, mobility, detecting, analysing, and recommending solutions to boost your operation and maintenance activities.

The drive is EcoStruxure-ready, providing a complete integrated solution for overall equipment effectiveness.

It allows you to save time and exploit the full range of capabilities of your equipment on a single platform.

- EcoStruxure PES and Modicon™ M580-compatible, enabling use of dedicated libraries for quicker product implementation and commissioning
- DTM library and application function blocks provide full programming and diagnostic functions
- EcoStruxure Asset Advisor uses the drive as a super sensor for predictive maintenance

Tailored solutions

Deliver solutions to optimize your operation efficiency and investment (time & expenditure)

- Delivers a highly versatile platform to meet demanding customer requirements beyond those of standard drives
- Provides a high level of customization to fit specific purposes
- Offers flexibility with electrical or mechanical modifications and extensions easily delivered
- Utilizes a simplified design process and shortened system implementation time

Application



Mining, Mineral & Metals

- Long Distance Conveyor
- Single/Multi Flat Conveyor
- Belt Conveyor
- Sintering/Dedusting / ID Fan/Mill Fan
- Blast Furnace
- Slurry Pump/Cyclone
- HPGR
- SAG Mill / Ball Mill / Vertical Mill



Oil & Gas

- ESP (Electrical Submersible Pump)
- Crude Oil Transfer Pump
- Distribution Pipeline Compressor
- Pipeline Pumps
- Load Commutated Inverter Retrofit
- LNG Compressor
- Fans/Pumps/Compressors/Mixer (Refining)
- Petrochemical Fan/Pump/Extruder
- FPSO



Water & Wastewater

- Natural Spring/Well
- Electrical Submersible Pump
- Raw Water Intake Pump
- Booster Pump
- Multi-pump Station
- Distribution Pump
- Desalination Pumps
- Wastewater Treatment Pumps
- Water Purification Pumps



Power Plant

- GT Starters, Fuel Gas Booster Compressors, Boiler (HRSG)
- Feed-water Pumps/Cooling Water Pumps
- Circulation water pump
- Primary/Secondary Draft Fan/ID fans
- Coal belt conveyor
- Coal vertical mill

Typical Control Functions Used for Applications

Function	MMM					WWW					O&G					Power Plant					
	Long-distance conveyor	Slurry pump	SAG/ball mill	HPGR	ID/FD fans	Raw water pump	Lifting station	Blower/compressor	Booster pump	High-pressure pumps	ESP	Crude oil transfer pump	Pipeline compressor	ID/FD fans	Extruder	Mixer	Feed water pump	ID/FD fans	Coal mill	Cooling water circulation pump	Fuel gas compressor
Soft start function, incl. synchronization, and bypass	✓		✓			✓	✓	✓	✓	✓		✓	✓				✓			✓	✓
Speed and torque control mode	✓		✓	✓											✓	✓					
Master slave up to 10 drives	✓		✓	✓											✓	✓					
Torque regulation	✓		✓	✓											✓	✓					
Gliding current control		✓				✓				✓	✓						✓			✓	
Mechanical Backlash compensation			✓	✓											✓		✓				
Master/Slave management	✓		✓	✓											✓	✓			✓		
Master/Slave on rigid coupling	✓		✓												✓	✓					
Master/Slave on elastic coupling	✓			✓																	
Load sharing (drop control)	✓		✓	✓																	
Pump characteristics setting		✓				✓	✓		✓	✓	✓						✓			✓	

Typical Monitoring Functions Used for Applications

Function	MMM					WWW					O&G					Power Plant						
	Long-distance conveyor	Slurry pump	SAG/ball mill	HPGR	ID/ID fans	Raw water pump	Lifting station	Blower/compressor	Booster pump	High-pressure pumps	ESP	Crude oil transfer pump	Pipeline compressor	ID/ID fans	Extruder	Mixer	Feed water pump	ID/ID fans	Coal mill	Cooling water circulation pump	Fuel gas compressor	
External error	✓	✓	✓	✓	✓	✓	✓	✓	✓	✓	✓	✓	✓	✓	✓	✓	✓	✓	✓	✓	✓	✓
External error processing	✓	✓	✓	✓	✓	✓	✓	✓	✓	✓	✓	✓	✓	✓	✓	✓	✓	✓	✓	✓	✓	✓
Catch on the fly				✓	✓			✓			✓			✓				✓				
Torque limitation	✓		✓	✓			✓			✓	✓				✓	✓			✓			
Current limitation	✓		✓	✓						✓	✓				✓	✓			✓			
2nd current limitation	✓			✓							✓				✓	✓			✓			
Encoder check	✓		✓												✓	✓						
Reverse disable		✓			✓	✓	✓	✓	✓	✓	✓	✓	✓	✓	✓		✓	✓	✓	✓	✓	✓
Under/Overload detection	✓	✓	✓	✓						✓	✓		✓		✓	✓			✓			
Mechanical resonance rejection	✓	✓	✓	✓	✓	✓	✓	✓	✓	✓	✓	✓	✓	✓	✓	✓	✓	✓	✓	✓	✓	✓
Stall monitoring	✓	✓	✓	✓			✓				✓			✓	✓	✓		✓	✓			
Ramp tracking	✓		✓	✓				✓					✓		✓	✓			✓			✓
Pump monitoring functions		✓				✓	✓		✓	✓	✓	✓					✓			✓		
Sensorless pump flow calculation		✓				✓	✓		✓	✓	✓	✓					✓			✓		
Energy measurement and savings calculation	✓	✓	✓	✓	✓	✓	✓	✓	✓	✓	✓	✓	✓	✓	✓	✓	✓	✓	✓	✓	✓	✓
Oscilloscope function	✓	✓	✓	✓	✓	✓	✓	✓	✓	✓	✓	✓	✓	✓	✓	✓	✓	✓	✓	✓	✓	✓
Operating time	✓	✓	✓	✓	✓	✓	✓	✓	✓	✓	✓	✓	✓	✓	✓	✓	✓	✓	✓	✓	✓	✓
1-year Trend recording	✓	✓	✓	✓	✓	✓	✓	✓	✓	✓	✓	✓	✓	✓	✓	✓	✓	✓	✓	✓	✓	✓
Error storage and history with actual values	✓	✓	✓	✓	✓	✓	✓	✓	✓	✓	✓	✓	✓	✓	✓	✓	✓	✓	✓	✓	✓	✓

Typical Configuration Management Used for Applications

Function	MMM					WWW					O&G					Power Plant					
	Long-distance conveyor	Slurry pump	SAG/ball mill	HPGR	ID/FD fans	Raw water pump	Lifting station	Blower/compressor	Booster pump	High-pressure pumps	ESP	Crude oil transfer pump	Pipeline compressor	ID/FD fans	Extruder	Mixer	Feed water pump	ID/FD fans	Coal mill	Cooling water circulation pump	Fuel gas compressor
Motor-/ Configuration switching	✓	✓	✓	✓			✓		✓						✓	✓			✓		
Threshold value reached (current, frequency...)	✓	✓	✓	✓	✓	✓	✓	✓	✓	✓	✓	✓	✓	✓	✓	✓	✓	✓	✓	✓	✓
Output phase rotation	✓	✓	✓	✓	✓	✓	✓	✓	✓	✓	✓	✓	✓	✓	✓	✓	✓	✓	✓	✓	✓
Automatic Fault Reset	✓				✓		✓						✓					✓			
Parameter customization	✓									✓											
Pulse input configuration	✓		✓		✓								✓					✓	✓		
Dual rating	✓		✓	✓				✓		✓					✓	✓			✓		✓
Skip frequencies selection	✓	✓	✓	✓	✓	✓	✓	✓	✓	✓	✓	✓	✓	✓	✓	✓	✓	✓	✓	✓	✓
Motor auto tuning function	✓	✓	✓	✓	✓	✓	✓	✓	✓	✓	✓	✓	✓	✓	✓	✓	✓	✓	✓	✓	✓
Preset speeds setting	✓		✓					✓					✓		✓	✓			✓		✓
Ramp type setting	✓			✓						✓											✓
Ramp switching	✓		✓	✓			✓			✓								✓	✓		✓
Motor potentiometer function			✓	✓											✓						

Standards and regulations

The entire ATV6000 range conforms to international requirements in order to provide efficient and appropriate usage of products by the end user, machine manufacturer or system integrator.



Low voltage directive (LVD)

As declared by the CE mark, the mechanical and electrical design of the Low voltage cabinet (control cabinet) meets the European Directive LVD 2014/35/EU with regards to the harmonized standard EN/IEC 61800-5-1.

As described on the technical construction file, the mechanical and electrical design of Medium voltage parts meets the harmonized standard EN/IEC 61800-5-1.

Electromagnetic compatibility directive (EMC)

As declared by the CE mark, ATV6000 fulfills the requirements of the European Directive EMC 2014/30/EU with regards to the harmonized standard EN/IEC 61800-3.

Machine directive

The ATV6000 drive is to be installed as a part of a machine, system or plant. The responsibility of the machine manufacturer or system integrator is involved as it refers to the method of installation. An appropriate usage of products helps to ensure the compliance to the machine directive with regards to the IEC standards 61800-5-1. Drive operation remains totally prohibited without prior establishment of conformity by the machine manufacturer or integrator.

Drive topology

Its simple two level power cell design takes away the complexity of multilevel architecture and makes it into a clear and easy understandable technology. This reduces your maintenance cost because the crew will easily understand Altivar 6000.

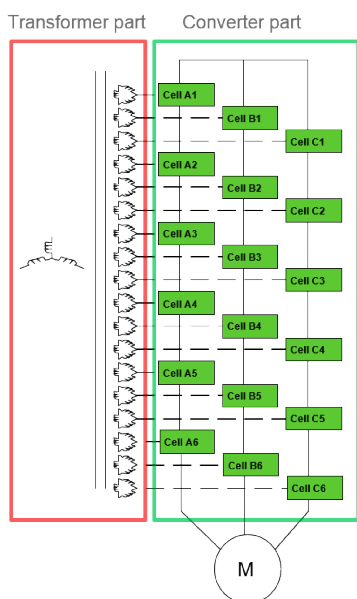

Fig. ATV6000 multilevel architecture

One of the core component of ATV6000 is the “Power cell”. This “Power cell” is a single phase, two level output switching device, supplied by a 700/720 V low voltage winding of a transformer.

The big advantage of this is, that the switching elements are state-of-the-art LV components. By putting this AC - supplies in series, higher voltages are achieved. The number of “Power cells” determines the output voltage. Every cell provides a small step of motor supply, resulting in a smooth waveform. Phase shifting can be done on the secondary windings of transformer, allowing an elimination of harmonics of input.

The cells create the right part of the drive and the transformer the left section of the drive. The drives regulation system and control system are installed at front of the drive to provide an optimized footprint. The transformer and cell section can be separated for easy installation. Adequate cooling fans on top of the cabinet are supplied by auxiliary power supply or by an additional secondary winding of the integrated transformer as an option

Schneider Electric offers this transformer (aluminum and copper) in a standard efficiency as well as in increased high efficiency.

The mains over-current monitoring is not provided by the drive system and must be managed upstream of the drive. (For more details refer to your local Schneider representative)

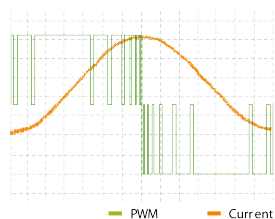

Fig. Typical output waveform of a single power cell

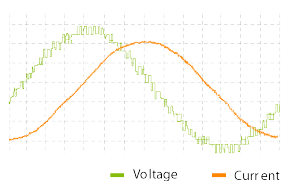

Fig. Output waveform

Benefits

- Easy understandable multilevel architecture saves money in case of maintenance
- Less spare parts because only one power cell design is needed for the whole drive
- Smooth output voltage because each power cell provides only a small step of the voltage
- Typical THDI down to 1.5%⁽¹⁾ (grid side)
- Typical THDU <2%⁽¹⁾ (motor side)
- Typical Power Cell Carrier Frequency: 610 Hz

(1) Value may slightly change depending on drive's rating.

Device basic information

Control and Transformer cabinet

Clever and modular arrangement of control section in front of transformer. This section with independent access allows the integration of additional components according to your personal needs.

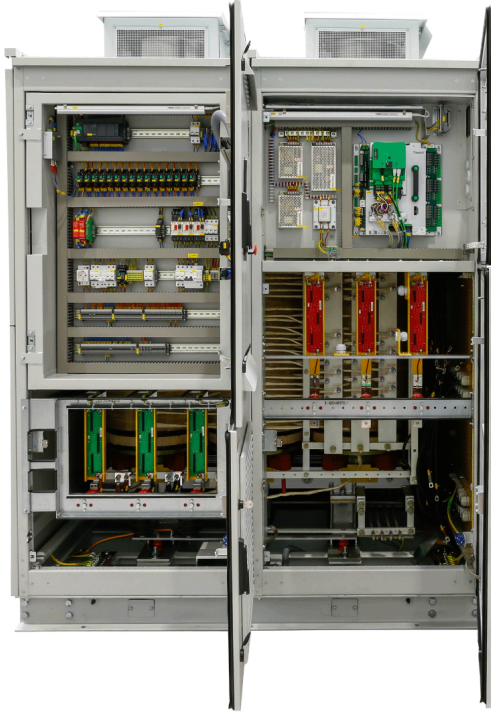

Fig. Control and transformer cabinet

Benefits

- Space optimized dimensions without squeezing components in small compartments, granting you a very long lifetime avoiding any hot spot inside the system.
- The integrated transformer and multilevel structure helps to avoid bearing currents in existing motors. This results in a capability to run your old motor on a new MV drive, with conditions, leading to a drastic reduction of energy costs where your damper controlled fan or throttle controlled pump is concerned.

Power cells cabinet

The power cells cabinet contains the inverter function of the ATV6000. It is a modular cabinet that can be used with the transformer cabinet according to the implementation requirements. The power cells are placed onto a fast-track system providing a convenient access to it.



Fig. Power cells cabinet and Power cell

Benefits

- Clear arrangement of components helping your team in maintenance and service
- Compact and low weight cell design saving maintenance shutdown time
- Easier installation to save time

Control features

Friendly and easy-to-use interface with 10" Magelis touch-screen. Windows arrangement to guide you in few touches to the required result.

- Motor control mode
 - Vector control mode
 - Energy efficiency mode
 - With or without encoder
- Application control mode
 - Speed control
 - Torque control
- Number of quadrant
 - 2Q
- Steady operation
 - Speed precision in steady state: $\pm 0.5\%$
 - Closed-loop speed precision: $\pm 0.1\%$
- Monitoring (Monitoring functions which help to protect)
 - Overcurrent, overvoltage, undervoltage, controller shutdown, cooling fan stop, overload, overtemperature, communication interruption, ground fault, phase loss, etc.
- Communication
 - Ethernet dual port connector, sporting Ethernet IP and Modbus TCP
 - Modbus SL connector
 - Fieldbus options for Profibus, Profinet, EtherCAT, DeviceNet, CANopen
- PID function
 - Integrated PID controller, and parameters can be set.
- I/O function
 - Variety different analog and digital I/Os, extendable on customer request.
- Operation mode
 - Local/remote/panel (As an option)
- Human-Machine interface display
 - 10 inch large color LCD touch screen with graphic user surface.
 - Drive status pilot lights for ready, run, warning and error.
 - Output frequency, voltage, current, power and input voltage, current, power, power factor, parameter settings, voltage and current waveform, transformer temperature, drive status and records.
 - Comprehensive display for monitoring and maintenance data.
- Multi language for HMI: English, French, German, Spanish, Chinese, Russian. For other languages, contact your local Schneider Electric representative.

Key functions

- Soft start function, incl. synchronization and bypass
- Speed and torque control mode
- Master slave up to 10 drives
- Load sharing (droop control)
- Mechanical Backlash compensation
- Stall monitoring
- Pump characteristics setting
- Pump monitoring functions
- Sensor less pump flow calculation
- Energy measurement and savings calculation
- Oscilloscope function
- 1 year Trend recording
- Catch on the fly a spinning motor
- Skip frequencies selection
- Motor auto tuning function
- Error/warning messages history with actual values
- Preset speeds setting
- Ramp type setting
- Motor potentiometer function
- Parameter set switching

Selection and ordering data

Type designation

The product designation of the ATV6000 consists of several points of reference (characters and figures). The meaning of each point is illustrated in the following example.

For ATV6000

		ATV6000	C	470	A	66	66	N	A	3
Product Range										
ATV 6000										
Factor for power rating										
D x 1 kVA										
C x 10 kVA										
M x 100 kVA										
Transformer rating										
470 470										
...										
Cooling type										
A Air cooled										
R Redundant fan cooling										
Input voltage										
24 2.4 kV										
33 3.0 kV										
42 4.16 kV										
55 5.5 kV										
60 6.0 kV										
63 6.3 kV										
66 6.6 kV										
10 10 kV										
11 11 kV										
14 13.8 kV										
15 15 kV										
2A 20 kV										
2B 22 kV										
Output voltage										
24 2.4 kV										
...										
14 13.8 kV										
Style (1)										
N No bypass										
B Powercell bypass										
C Powercell bypass n+1										
D Powercell bypass n+2										
Standard										
A CE Standard										
B CE High efficiency										
C CE Optimized transformer										
G CSA Standard										
H CSA High efficiency										
J CSA Optimized										
IP rating										
3 IP31										
4 IP41										
5 IP42										

(1) Power cell bypass is available up to 490 A

Selection and ordering data

Voltage class 2.4 kV

Power specifications for output voltage 2.4 kV, 9 power cells, 18 input pulses											
Model	Transformer rating (1)	Normal duty				Heavy duty				Power cell	
		Maximum motor shaft power (2)		Nominal continuous current	120% overload 1 min/10 mins	Maximum motor shaft power (2)		Nominal continuous current	150% overload 1 min/10 mins	Individual power cell rating	Max overload 3 sec/10 mins
		kVA	kW	HP	A	A	kW	HP	A	A	A
Voltage class: 2.4 kV (3)											
ATV6000D200A2424●●●	200	160	214	46	55.2	150	201	44	66	65	97.5
ATV6000D280A2424●●●	280	220	295	65	78	180	241	52	78	65	97.5
ATV6000D350A2424●●●	350	280	375	80.6	96.7	260	348	77	116	100	150
ATV6000D430A2424●●●	430	340	455	100	120	270	362	80	120	100	150
ATV6000D570A2424●●●	570	450	603	130	155	410	549	120	180	150	225
ATV6000D650A2424●●●	650	520	697	150	180	410	549	120	180	150	225
ATV6000D790A2424●●●	790	630	844	181	218	550	737	160	240	200	300
ATV6000D950A2424●●●	950	760	1019	220	264	610	818	176	264	220	330
ATV6000C122A2424●●●	1220	970	1300	280	336	770	1032	224	336	280	420
ATV6000C139A2424●●●	1390	1100	1475	320	384	880	1180	256	384	320	480
ATV6000C163A2424●●●	1630	1300	1743	374	449	1130	1515	328	492	410	615
ATV6000C178A2424●●●	1780	1420	1904	410	492	1130	1515	328	492	410	615
ATV6000C200A2424●●●	2000	1600	2145	460	552	1360	1823	392	588	490	735
ATV6000C213A2424●●●	2130	1700	2279	490	588	1360	1823	392	588	490	735
ATV6000C225A2424●●●	2250	1800	2413	518	622	1520	2038	440	660	550	825
ATV6000C239A2424●●●	2390	1910	2561	550	660	1520	2038	440	660	550	825
ATV6000C275A2424●●●	2750	2200	2950	633	760	2000	2682	576	864	720	1080
ATV6000C313A2424●●●	3130	2500	3352	720	864	2000	2682	576	864	720	1080
ATV6000C338A2424●●●	3380	2700	3620	777	932	2360	3164	680	1020	850	1275
ATV6000C369A2424●●●	3690	2950	3956	850	1020	2360	3164	680	1020	850	1275
ATV6000C400A2424●●●	4000	3200	4291	921	1105	2780	3728	800	1200	1000	1500
ATV6000C434A2424●●●	4340	3470	4653	1000	1200	2780	3728	800	1200	1000	1500
<p>(1) For higher drive power please contact Schneider Electric.</p> <p>(2) Values valid for synchronous motor and asynchronous motor. The specifications for the maximum motor shaft power is based on a motor efficiency of 95%, and power factor 0.88.</p> <p>(3) Please contact Schneider Electric for other combinations of input and output voltage.</p> <p>NOTE: For dimensions and outline drawings please refer to chapter Technical Data, page 50.</p>											

Voltage class 3.3 kV

Power specifications for output voltage 3.3 kV, 9 power cells, 18 input pulses											
Model	Transformer rating (1)	Normal duty				Heavy duty				Power cell	
		Maximum motor shaft power (2)		Nominal continuous current	120% overload 1 min/10 mins	Maximum motor shaft power (2)		Nominal continuous current	150% overload 1 min/10 mins	Individual power cell rating	Max overload 3 sec/10 mins
		kVA	kW	HP	A	A	kW	HP	A	A	A
Voltage class: 3.3 kV (3)											
ATV6000D390A3333●●●	390	310	415	65	78	240	321	52	78	65	97.5
ATV6000D500A3333●●●	500	400	536	83.7	100	380	509	80	120	100	150
ATV6000D590A3333●●●	590	470	630	100	120	380	509	80	120	100	150
ATV6000D700A3333●●●	700	560	750	117	141	530	710	112	168	150	225
ATV6000D790A3333●●●	790	630	844	132	158	570	764	120	180	150	225
ATV6000D890A3333●●●	890	710	952	150	180	570	764	120	180	150	225
ATV6000C100A3333●●●	1000	800	1072	167	201	760	1019	160	240	200	300
ATV6000C113A3333●●●	1130	900	1206	188	226	760	1019	160	240	200	300
ATV6000C132A3333●●●	1320	1050	1408	220	264	840	1126	176	264	220	330
ATV6000C150A3333●●●	1500	1200	1609	251	301	1070	1434	224	336	280	420
ATV6000C167A3333●●●	1670	1330	1783	280	336	1070	1434	224	336	280	420
ATV6000C190A3333●●●	1900	1520	2038	320	384	1220	1636	256	384	320	480
ATV6000C213A3333●●●	2130	1700	2279	356	427	1560	2091	328	492	410	615
ATV6000C244A3333●●●	2440	1950	2614	410	492	1560	2091	328	492	410	615
ATV6000C293A3333●●●	2930	2340	3137	490	588	1870	2507	392	588	490	735
ATV6000C328A3333●●●	3280	2620	3513	550	660	2100	2816	440	660	550	825
ATV6000C350A3333●●●	3500	2800	3754	586	703	2690	3607	563	845	720	1080
ATV6000C388A3333●●●	3880	3100	4157	649	779	2750	3687	576	864	720	1080
ATV6000C430A3333●●●	4300	3440	4613	720	864	2750	3687	576	864	720	1080
ATV6000C463A3333●●●	4630	3700	4961	774	929	3240	4344	680	1020	850	1275
ATV6000C508A3333●●●	5080	4060	5444	850	1020	3240	4344	680	1020	850	1275
ATV6000C550A3333●●●	5500	4400	5900	921	1105	3820	5122	800	1200	1000	1500
ATV6000C600A3333●●●	6000	4770	6396	1000	1200	3820	5122	800	1200	1000	1500

(1) For higher drive power please contact Schneider Electric.

(2) Values valid for synchronous motor and asynchronous motor. The specifications for the maximum motor shaft power is based on a motor efficiency of 95%, and power factor 0.88.

(3) Please contact Schneider Electric for other combinations of input and output voltage.

NOTE: For dimensions and outline drawings please refer to chapter Technical Data, page 50.

Voltage class 4.16 kV

Power specifications for output voltage 4.16 kV, 12 power cells, 24 input pulses											
Model	Transformer rating (1)	Normal duty				Heavy duty				Power cell	
		Maximum motor shaft power (2)		Nominal continuous current	120% overload 1 min/10 mins	Maximum motor shaft power (2)		Nominal continuous current	150% overload 1 min/10 mins	Individual power cell rating	Max overload 3 sec/10 mins
		kVA	kW	HP	A	A	kW	HP	A	A	A
Voltage class: 4.16 kV (3)											
ATV6000D350A4242●●●	350	280	375	46.5	55.8	260	348	44	66	65	97.5
ATV6000D490A4242●●●	490	390	522	65	78	310	415	52	78	65	97.5
ATV6000D570A4242●●●	570	450	603	74.7	89.6	420	563	71	107	100	150
ATV6000D630A4242●●●	630	500	670	83	99.6	470	630	79	119	100	150
ATV6000D750A4242●●●	750	600	804	100	120	480	643	80	120	100	150
ATV6000D890A4242●●●	890	710	952	118	141	680	911	113	170	150	225
ATV6000C100A4242●●●	1000	800	1072	133	159	720	965	120	180	150	225
ATV6000C113A4242●●●	1130	900	1206	150	180	720	965	120	180	150	225
ATV6000C125A4242●●●	1250	1000	1341	166	199	950	1273	159	239	200	300
ATV6000C150A4242●●●	1500	1200	1609	199	239	960	1287	160	240	200	300
ATV6000C165A4242●●●	1650	1320	1770	220	264	1060	1421	176	264	220	330
ATV6000C188A4242●●●	1880	1500	2011	249	299	1340	1796	224	336	280	420
ATV6000C210A4242●●●	2100	1680	2252	280	336	1340	1796	224	336	280	420
ATV6000C240A4242●●●	2400	1920	2574	320	384	1540	2065	256	384	320	480
ATV6000C275A4242●●●	2750	2200	2950	365	438	1970	2641	328	492	410	615
ATV6000C308A4242●●●	3080	2460	3298	410	492	1970	2641	328	492	410	615
ATV6000C338A4242●●●	3380	2700	3620	448	538	2360	3164	392	588	490	735
ATV6000C369A4242●●●	3690	2950	3956	490	588	2360	3164	392	588	490	735
ATV6000C414A4242●●●	4140	3310	4438	550	660	2650	3553	440	660	550	825
ATV6000C463A4242●●●	4630	3700	4961	614	737	3460	4639	576	864	720	1080
ATV6000C500A4242●●●	5000	4000	5364	664	797	3460	4639	576	864	720	1080
ATV6000C542A4242●●●	5420	4330	5806	720	864	3460	4639	576	864	720	1080
ATV6000C600A4242●●●	6000	4800	6436	797	956	4090	5484	680	1020	850	1275
ATV6000C640A4242●●●	6400	5120	6866	850	1020	4090	5484	680	1020	850	1275
ATV6000C700A4242●●●	7000	5600	7509	930	1116	4810	6450	800	1200	1000	1500
ATV6000C753A4242●●●	7530	6020	8072	1000	1200	4810	6450	800	1200	1000	1500

(1) For higher drive power please contact Schneider Electric.

(2) Values valid for synchronous motor and asynchronous motor. The specifications for the maximum motor shaft power is based on a motor efficiency of 95%, and power factor 0.88.

(3) Please contact Schneider Electric for other combinations of input and output voltage.

NOTE: For dimensions and outline drawings please refer to chapter Technical Data, page 50.

Voltage class 5.5 kV

Power specifications for output voltage 5.5 kV, 15 power cells, 30 input pulses											
Model	Transformer rating (1)	Normal duty				Heavy duty				Power cell	
		Maximum motor shaft power (2)		Nominal continuous current	120% overload 1 min/10 mins	Maximum motor shaft power (2)		Nominal continuous current	150% overload 1 min/10 mins	Individual power cell rating	Max overload 3 sec/10 mins
		kVA	kW	HP	A	A	kW	HP	A	A	A
Voltage class: 5.5 kV (3)											
ATV6000D450A5555●●●	450	355	476	44.6	53.5	330	442	42	63	65	97.5
ATV6000D570A5555●●●	570	450	603	56.5	67.8	410	549	52	78	65	97.5
ATV6000D640A5555●●●	640	510	683	65	78	410	549	52	78	65	97.5
ATV6000D790A5555●●●	790	630	844	79.1	94.9	600	804	76	114	100	150
ATV6000D890A5555●●●	890	710	952	89.2	107	630	844	80	120	100	150
ATV6000D990A5555●●●	990	790	1059	100	120	630	844	80	120	100	150
ATV6000C113A5555●●●	1130	900	1206	113	136	860	1153	108	162	150	225
ATV6000C132A5555●●●	1320	1050	1408	132	158	950	1273	120	180	150	225
ATV6000C149A5555●●●	1490	1190	1595	150	180	950	1273	120	180	150	225
ATV6000C169A5555●●●	1690	1350	1810	170	203	1270	1703	160	240	200	300
ATV6000C199A5555●●●	1990	1590	2132	200	240	1270	1703	160	240	200	300
ATV6000C219A5555●●●	2190	1750	2346	220	264	1400	1877	176	264	220	330
ATV6000C250A5555●●●	2500	2000	2682	251	301	1780	2387	224	336	280	420
ATV6000C278A5555●●●	2780	2220	2977	280	336	1780	2387	224	336	280	420
ATV6000C318A5555●●●	3180	2540	3406	320	384	2030	2722	256	384	320	480
ATV6000C350A5555●●●	3500	2800	3754	352	422	2610	3500	328	492	410	615
ATV6000C375A5555●●●	3750	3000	4023	377	452	2610	3500	328	492	410	615
ATV6000C408A5555●●●	4080	3260	4371	410	492	2610	3500	328	492	410	615
ATV6000C488A5555●●●	4880	3900	5229	490	588	3120	4183	392	588	490	735
ATV6000C538A5555●●●	5380	4300	5766	550	660	3500	4693	440	660	550	825
ATV6000C600A5555●●●	6000	4800	6436	603	723	4580	6141	576	864	720	1080
ATV6000C663A5555●●●	6630	5300	7107	666	799	4580	6141	576	864	720	1080
ATV6000C717A5555●●●	7170	5730	7684	720	864	4580	6141	576	864	720	1080
ATV6000C775A5555●●●	7750	6200	8314	779	934	5410	7254	680	1020	850	1275
ATV6000C845A5555●●●	8450	6760	9065	850	1020	5410	7254	680	1020	850	1275
ATV6000C925A5555●●●	9250	7400	9923	929	1115	6370	8542	800	1200	1000	1500
ATV6000M100A5555●●●	10000	7960	10674	1000	1200	6370	8542	800	1200	1000	1500

(1) For higher drive power please contact Schneider Electric.

(2) Values valid for synchronous motor and asynchronous motor. The specifications for the maximum motor shaft power is based on a motor efficiency of 95%, and power factor 0.88.

(3) Please contact Schneider Electric for other combinations of input and output voltage.

NOTE: For dimensions and outline drawings please refer to chapter Technical Data, page 50.

Voltage class 6 kV

Power specifications for output voltage 6 kV, 15 power cells, 30 input pulses											
Model	Transformer rating (1)	Normal duty				Heavy duty				Power cell	
		Maximum motor shaft power (2)		Nominal continuous current	120% overload 1 min/10 mins	Maximum motor shaft power (2)		Nominal continuous current	150% overload 1 min/10 mins	Individual power cell rating	Max overload 3 sec/10 mins
		kVA	kW	HP	A	A	kW	HP	A	A	A
Voltage class: 6 kV (3)											
ATV6000D450A6060●●●	450	355	476	40.9	49	330	442	39	58.5	65	97.5
ATV6000D570A6060●●●	570	450	603	51.8	62.1	420	563	49	73.5	65	97.5
ATV6000D700A6060●●●	700	560	750	65	78	450	603	52	78	65	97.5
ATV6000D790A6060●●●	790	630	844	72.5	87	590	791	69	104	100	150
ATV6000D890A6060●●●	890	710	952	81.7	98	670	898	78	117	100	150
ATV6000C108A6060●●●	1080	860	1153	100	120	690	925	80	120	100	150
ATV6000C125A6060●●●	1250	1000	1341	115	138	950	1273	110	165	150	225
ATV6000C138A6060●●●	1380	1100	1475	127	152	1040	1394	120	180	150	225
ATV6000C163A6060●●●	1630	1300	1743	150	180	1040	1394	120	180	150	225
ATV6000C188A6060●●●	1880	1500	2011	173	207	1390	1864	160	240	200	300
ATV6000C213A6060●●●	2130	1700	2279	196	235	1390	1864	160	240	200	300
ATV6000C239A6060●●●	2390	1910	2561	220	264	1520	2038	176	264	220	330
ATV6000C263A6060●●●	2630	2100	2816	242	290	1940	2601	224	336	280	420
ATV6000C304A6060●●●	3040	2430	3258	280	336	1940	2601	224	336	280	420
ATV6000C348A6060●●●	3480	2780	3728	320	384	2220	2977	256	384	320	480
ATV6000C375A6060●●●	3750	3000	4023	345	414	2840	3808	328	492	410	615
ATV6000C413A6060●●●	4130	3300	4425	380	456	2840	3808	328	492	410	615
ATV6000C445A6060●●●	4450	3560	4774	410	492	2840	3808	328	492	410	615
ATV6000C532A6060●●●	5320	4250	5699	490	588	3400	4559	392	588	490	735
ATV6000C588A6060●●●	5880	4700	6302	550	660	3820	5122	440	660	550	825
ATV6000C638A6060●●●	6380	5100	6839	587	704	4900	6571	564	846	720	1080
ATV6000C688A6060●●●	6880	5500	7375	633	760	5000	6705	576	864	720	1080
ATV6000C782A6060●●●	7820	6250	8381	720	864	5000	6705	576	864	720	1080
ATV6000C863A6060●●●	8630	6900	9253	794	953	5900	7912	680	1020	850	1275
ATV6000C924A6060●●●	9240	7390	9910	850	1020	5900	7912	680	1020	850	1275
ATV6000M100A6060●●●	10000	8000	10728	921	1105	6950	9320	800	1200	1000	1500
ATV6000M109A6060●●●	10900	8680	11640	1000	1200	6950	9320	800	1200	1000	1500

(1) For higher drive power please contact Schneider Electric.

(2) Values valid for synchronous motor and asynchronous motor. The specifications for the maximum motor shaft power is based on a motor efficiency of 95%, and power factor 0.88.

(3) Please contact Schneider Electric for other combinations of input and output voltage.

NOTE: For dimensions and outline drawings please refer to chapter Technical Data, page 50.

Voltage class 6.3 kV

Power specifications for output voltage 6.3 kV, 15 power cells, 30 input pulses											
Model	Transformer rating (1)	Normal duty				Heavy duty				Power cell	
		Maximum motor shaft power (2)	Nominal continuous current	120% overload 1 min/10 mins	Maximum motor shaft power (2)	Nominal continuous current	150% overload 1 min/10 mins	Individual power cell rating	Max overload 3 sec/10 mins		
										kVA	kW
Voltage class: 6.3 kV (3)											
ATV6000D450A6363●●●	450	355	476	38.9	46.6	330	442	37	55.5	65	97.5
ATV6000D570A6363●●●	570	450	603	49.3	59.1	420	563	47	70.5	65	97.5
ATV6000D630A6363●●●	630	500	670	54.8	65.7	470	630	52	78	65	97.5
ATV6000D740A6363●●●	740	590	791	65	78	470	630	52	78	65	97.5
ATV6000D790A6363●●●	790	630	844	69.1	82.9	600	804	66	99	100	150
ATV6000D890A6363●●●	890	710	952	77.8	93.3	670	898	74	111	100	150
ATV6000C114A6363●●●	1140	910	1220	100	120	720	965	80	120	100	150
ATV6000C132A6363●●●	1320	1050	1408	115	138	1000	1341	110	165	150	225
ATV6000C150A6363●●●	1500	1200	1609	132	158	1090	1461	120	180	150	225
ATV6000C170A6363●●●	1700	1360	1823	150	180	1090	1461	120	180	150	225
ATV6000C194A6363●●●	1940	1550	2078	170	204	1450	1944	160	240	200	300
ATV6000C228A6363●●●	2280	1820	2440	200	240	1450	1944	160	240	200	300
ATV6000C250A6363●●●	2500	2000	2682	220	264	1600	2145	176	264	220	330
ATV6000C282A6363●●●	2820	2250	3017	247	296	2040	2735	224	336	280	420
ATV6000C319A6363●●●	3190	2550	3419	280	336	2040	2735	224	336	280	420
ATV6000C364A6363●●●	3640	2910	3902	320	384	2330	3124	256	384	320	480
ATV6000C413A6363●●●	4130	3300	4425	362	434	2990	4009	328	492	410	615
ATV6000C468A6363●●●	4680	3740	5015	410	492	2990	4009	328	492	410	615
ATV6000C513A6363●●●	5130	4100	5498	449	539	3570	4787	392	588	490	735
ATV6000C558A6363●●●	5580	4460	5980	490	588	3570	4787	392	588	490	735
ATV6000C627A6363●●●	6270	5010	6718	550	660	4010	5377	440	660	550	825
ATV6000C688A6363●●●	6880	5500	7375	603	723	5250	7040	576	864	720	1080
ATV6000C750A6363●●●	7500	6000	8046	658	789	5250	7040	576	864	720	1080
ATV6000C820A6363●●●	8200	6560	8797	720	864	5250	7040	576	864	720	1080
ATV6000C888A6363●●●	8880	7100	9521	778	934	6200	8314	680	1020	850	1275
ATV6000C969A6363●●●	9690	7750	10392	850	1020	6200	8314	680	1020	850	1275
ATV6000M105A6363●●●	10500	8400	11264	921	1105	7290	9776	800	1200	1000	1500
ATV6000M114A6363●●●	11400	9120	12230	1000	1200	7290	9776	800	1200	1000	1500

(1) For higher drive power please contact Schneider Electric.

(2) Values valid for synchronous motor and asynchronous motor. The specifications for the maximum motor shaft power is based on a motor efficiency of 95%, and power factor 0.88.

(3) Please contact Schneider Electric for other combinations of input and output voltage.

NOTE: For dimensions and outline drawings please refer to chapter Technical Data, page 50.

Voltage class 6.6 kV

Power specifications for output voltage 6.6 kV, 15 (18) power cells, 30 (36) input pulses											
Model	Transformer rating (1)	Normal duty				Heavy duty				Power cell	
		Maximum motor shaft power (2)		Nominal continuous current	120% overload 1 min/10 mins	Maximum motor shaft power (2)		Nominal continuous current	150% overload 1 min/10 mins	Individual power cell rating	Max overload 3 sec/10 mins
		kVA	kW	HP	A	A	kW	HP	A	A	A
Voltage class: 6.6 kV (3)											
ATV6000D450A6666●●●	450	355	476	37.1	44.5	330	442	35	52.5	65	97.5
ATV6000D570A6666●●●	570	450	603	47.1	56.5	430	576	45	67.5	65	97.5
ATV6000D630A6666●●●	630	500	670	52.3	62.7	470	630	50	75	65	97.5
ATV6000D780A6666●●●	780	620	831	65	78	590	791	62	93	100	150
ATV6000D890A6666●●●	890	710	952	74.3	89.1	670	898	71	107	100	150
ATV6000C100A6666●●●	1000	800	1072	83.7	100	760	1019	80	120	100	150
ATV6000C119A6666●●●	1190	950	1273	100	120	760	1019	80	120	100	150
ATV6000C138A6666●●●	1380	1100	1475	115	138	1050	1408	110	165	150	225
ATV6000C163A6666●●●	1630	1300	1743	136	163	1140	1528	120	180	150	225
ATV6000C179A6666●●●	1790	1430	1917	150	180	1140	1528	120	180	150	225
ATV6000C200A6666●●●	2000	1600	2145	167	201	1520	2038	160	240	200	300
ATV6000C225A6666●●●	2250	1800	2413	188	226	1520	2038	160	240	200	300
ATV6000C263A6666●●●	2630	2100	2816	220	264	2010	2695	211	317	280	420
ATV6000C288A6666●●●	2880	2300	3084	241	289	2140	2869	224	336	280	420
ATV6000C334A6666●●●	3340	2670	3580	280	336	2140	2869	224	336	280	420
ATV6000C382A6666●●●	3820	3050	4090	320	384	2930	3929	307	461	410	615
ATV6000C425A6666●●●	4250	3400	4559	356	427	3130	4197	328	492	410	615
ATV6000C489A6666●●●	4890	3910	5243	410	492	3740	5015	392	588	490	735
ATV6000C538A6666●●●	5380	4300	5766	450	540	3740	5015	392	588	490	735
ATV6000C585A6666●●●	5850	4680	6275	490	588	3740	5015	392	588	490	735
ATV6000C657A6666●●●	6570	5250	7040	550	660	5040	6758	528	792	720	1080
ATV6000C713A6666●●●	7130	5700	7643	596	716	5470	7335	573	860	720	1080
ATV6000C775A6666●●●	7750	6200	8314	649	779	5500	7375	576	864	720	1080
ATV6000C860A6666●●●	8600	6880	9226	720	864	6490	8703	680	1020	850	1275
ATV6000C925A6666●●●	9250	7400	9923	774	929	6490	8703	680	1020	850	1275
ATV6000M102A6666●●●	10200	8120	10889	850	1020	7640	10245	800	1200	1000	1500
ATV6000M110A6666●●●	11000	8800	11800	921	1105	7640	10245	800	1200	1000	1500
ATV6000M120A6666●●●	12000	9550	12806	1000	1200	7640	10245	800	1200	1000	1500

(1) For higher drive power please contact Schneider Electric.

(2) Values valid for synchronous motor and asynchronous motor. The specifications for the maximum motor shaft power is based on a motor efficiency of 95%, and power factor 0.88.

(3) Please contact Schneider Electric for other combinations of input and output voltage.

NOTE: For dimensions and outline drawings please refer to chapter Technical Data, page 50.

Voltage class 10 kV

Power specifications for output voltage 10 kV, 24 power cells, 48 input pulses											
Model	Transformer rating (1)	Normal duty				Heavy duty				Power cell	
		Maximum motor shaft power (2)		Nominal continuous current	120% overload 1 min/10 mins	Maximum motor shaft power (2)		Nominal continuous current	150% overload 1 min/10 mins	Individual power cell rating	Max overload 3 sec/10 mins
		kVA	kW	HP	A	A	kW	HP	A	A	A
Voltage class: 10 kV (3)											
ATV6000D450A1010●●●	450	355	476	24.5	29.4	330	442	23	34.5	35	52.5
ATV6000D500A1010●●●	500	400	536	27.6	33.1	370	496	26	39.0	35	52.5
ATV6000D630A1010●●●	630	500	670	35	42	400	536	28	42	35	52.5
ATV6000D700A1010●●●	700	560	750	38.7	46.4	530	710	37	55.5	65	97.5
ATV6000D790A1010●●●	790	630	844	43.5	52.2	590	791	41	61.5	65	97.5
ATV6000D890A1010●●●	890	710	952	49	58.8	680	911	47	70.5	65	97.5
ATV6000C100A1010●●●	1000	800	1072	55.2	66.2	750	1005	52	78	65	97.5
ATV6000C118A1010●●●	1180	940	1260	65	78	750	1005	52	78	65	97.5
ATV6000C138A1010●●●	1380	1100	1475	76	91.2	1050	1408	73	110	100	150
ATV6000C150A1010●●●	1500	1200	1609	82.9	99.4	1140	1528	79	119	100	150
ATV6000C180A1010●●●	1800	1440	1931	100	120	1150	1542	80	120	100	150
ATV6000C200A1010●●●	2000	1600	2145	111	133	1530	2051	106	159	150	225
ATV6000C225A1010●●●	2250	1800	2413	124	149	1720	2306	119	179	150	225
ATV6000C272A1010●●●	2720	2170	2910	150	180	1730	2319	120	180	150	225
ATV6000C300A1010●●●	3000	2400	3218	166	199	2300	3084	159	239	200	300
ATV6000C325A1010●●●	3250	2600	3486	180	216	2310	3097	160	240	200	300
ATV6000C350A1010●●●	3500	2800	3754	193	232	2310	3097	160	240	200	300
ATV6000C398A1010●●●	3980	3180	4264	220	264	2540	3406	176	264	220	330
ATV6000C438A1010●●●	4380	3500	4693	242	290	3240	4344	224	336	280	420
ATV6000C507A1010●●●	5070	4050	5431	280	336	3240	4344	224	336	280	420
ATV6000C538A1010●●●	5380	4300	5766	297	356	3700	4961	256	384	320	480
ATV6000C579A1010●●●	5790	4630	6208	320	384	3700	4961	256	384	320	480
ATV6000C625A1010●●●	6250	5000	6705	345	414	4740	6356	328	492	410	615
ATV6000C742A1010●●●	7420	5930	7952	410	492	4740	6356	328	492	410	615
ATV6000C813A1010●●●	8130	6500	8716	449	539	5670	7603	392	588	490	735
ATV6000C887A1010●●●	8870	7090	9507	490	588	5670	7603	392	588	490	735
ATV6000C995A1010●●●	9950	7960	10674	550	660	6370	8542	440	660	550	825
ATV6000M107A1010●●●	10700	8500	11398	587	704	8160	10942	564	846	720	1080
ATV6000M115A1010●●●	11500	9200	12337	635	762	8340	11184	576	864	720	1080
ATV6000M131A1010●●●	13100	10420	13973	720	864	8340	11184	576	864	720	1080
ATV6000M143A1010●●●	14300	11400	15287	787	945	9840	13195	680	1020	850	1275
ATV6000M154A1010●●●	15400	12300	16494	850	1020	9840	13195	680	1020	850	1275
ATV6000M169A1010●●●	16900	13500	18103	932	1119	11580	15529	800	1200	1000	1500

Power specifications for output voltage 10 kV, 24 power cells, 48 input pulses											
Model	Transformer rating (1)	Normal duty				Heavy duty				Power cell	
		Maximum motor shaft power (2)		Nominal continuous current	120% overload 1 min/10 mins	Maximum motor shaft power (2)		Nominal continuous current	150% overload 1 min/10 mins	Individual power cell rating	Max overload 3 sec/10 mins
		kVA	kW	HP	A	A	kW	HP	A	A	A
Voltage class: 10 kV (3)											
ATV6000M181A1010●●●	18100	14470	19404	1000	1200	11580	15529	800	1200	1000	1500
<p>(1) For higher drive power please contact Schneider Electric.</p> <p>(2) Values valid for synchronous motor and asynchronous motor. The specifications for the maximum motor shaft power is based on a motor efficiency of 95%, and power factor 0.88.</p> <p>(3) Please contact Schneider Electric for other combinations of input and output voltage.</p> <p>NOTE: For dimensions and outline drawings please refer to chapter Technical Data, page 50.</p>											

Voltage class 11 kV

Power specifications for output voltage 11 kV, 27 power cells, 54 input pulses											
Model	Transformer rating (1)	Normal duty				Heavy duty				Power cell	
		Maximum motor shaft power (2)		Nominal continuous current	120% overload 1 min/10 mins	Maximum motor shaft power (2)		Nominal continuous current	150% overload 1 min/10 mins	Individual power cell rating	Max overload 3 sec/10 mins
		kVA	kW	HP	A	A	kW	HP	A	A	A
Voltage class: 11 kV (3)											
ATV6000D500A1111●●●	500	400	536	25.1	30.1	380	509	24	36	35	52.5
ATV6000D690A1111●●●	690	550	737	35	42	440	590	28	42	35	52.5
ATV6000D790A1111●●●	790	630	844	39.6	47.5	600	804	38	57	65	97.5
ATV6000C100A1111●●●	1000	800	1072	50.2	60.2	760	1019	48	72	65	97.5
ATV6000C129A1111●●●	1290	1030	1381	65	78	820	1099	52	78	65	97.5
ATV6000C150A1111●●●	1500	1200	1609	75.3	90.3	1140	1528	72	108	100	150
ATV6000C175A1111●●●	1750	1400	1877	87.9	105	1270	1703	80	120	100	150
ATV6000C199A1111●●●	1990	1590	2132	100	120	1270	1703	80	120	100	150
ATV6000C225A1111●●●	2250	1800	2413	113	136	1720	2306	108	162	150	225
ATV6000C250A1111●●●	2500	2000	2682	126	151	1910	2561	120	180	150	225
ATV6000C298A1111●●●	2980	2380	3191	150	180	1910	2561	120	180	150	225
ATV6000C325A1111●●●	3250	2600	3486	163	196	2480	3325	156	234	200	300
ATV6000C375A1111●●●	3750	3000	4023	188	226	2540	3406	160	240	200	300
ATV6000C438A1111●●●	4380	3500	4693	220	264	2800	3754	176	264	220	330
ATV6000C557A1111●●●	5570	4450	5967	280	336	3560	4774	224	336	280	420
ATV6000C637A1111●●●	6370	5090	6825	320	384	4070	5457	256	384	320	480
ATV6000C713A1111●●●	7130	5700	7643	358	429	5220	7000	328	492	410	615
ATV6000C817A1111●●●	8170	6530	8756	410	492	5220	7000	328	492	410	615
ATV6000C888A1111●●●	8880	7100	9521	446	535	6240	8367	392	588	490	735
ATV6000C975A1111●●●	9750	7800	10459	490	588	6240	8367	392	588	490	735
ATV6000M110A1111●●●	11000	8760	11747	550	660	7000	9387	440	660	550	825
ATV6000M125A1111●●●	12500	10000	13410	628	753	9170	12297	576	864	720	1080
ATV6000M144A1111●●●	14400	11460	15368	720	864	9170	12297	576	864	720	1080
ATV6000M159A1111●●●	15900	12700	17030	797	957	10830	14523	680	1020	850	1275
ATV6000M170A1111●●●	17000	13530	18144	850	1020	10830	14523	680	1020	850	1275
ATV6000M188A1111●●●	18800	15000	20115	942	1130	12740	17084	800	1200	1000	1500
ATV6000M199A1111●●●	19900	15920	21349	1000	1200	12740	17084	800	1200	1000	1500

(1) For higher drive power please contact Schneider Electric.

(2) Values valid for synchronous motor and asynchronous motor. The specifications for the maximum motor shaft power is based on a motor efficiency of 95%, and power factor 0.88.

(3) Please contact Schneider Electric for other combinations of input and output voltage.

NOTE: For dimensions and outline drawings please refer to chapter Technical Data, page 50.

Voltage class 13.8 kV

Power specifications for output voltage 13.8 kV, 33 power cells, 66 input pulses											
Model	Transformer rating (1)	Normal duty				Heavy duty				Power cell	
		Maximum motor shaft power (2)		Nominal continuous current	120% overload 1 min/10 mins	Maximum motor shaft power (2)		Nominal continuous current	150% overload 1 min/10 mins	Individual power cell rating	Max overload 3 sec/10 mins
	kVA	kW	HP	A	A	kW	HP	A	A	A	A
Voltage class: 13.8 kV (3)											
ATV6000D870A1414●●●	870	690	925	35	42	550	737	28	42	35	52.5
ATV6000C113A1414●●●	1130	900	1206	45	54	850	1139	43	64.5	65	97.5
ATV6000C138A1414●●●	1380	1100	1475	55	66	1030	1381	52	78	65	97.5
ATV6000C162A1414●●●	1620	1290	1729	65	78	1030	1381	52	78	65	97.5
ATV6000C188A1414●●●	1880	1500	2011	75.1	90.1	1430	1917	72	108	100	150
ATV6000C225A1414●●●	2250	1800	2413	90.1	108	1590	2132	80	120	100	150
ATV6000C249A1414●●●	2490	1990	2668	100	120	1590	2132	80	120	100	150
ATV6000C288A1414●●●	2880	2300	3084	115	138	2190	2936	110	165	150	225
ATV6000C325A1414●●●	3250	2600	3486	130	156	2390	3205	120	180	150	225
ATV6000C374A1414●●●	3740	2990	4009	150	180	2390	3205	120	180	150	225
ATV6000C413A1414●●●	4130	3300	4425	165	198	3150	4224	158	237	200	300
ATV6000C450A1414●●●	4500	3600	4827	180	216	3190	4277	160	240	200	300
ATV6000C500A1414●●●	5000	4000	5364	200	240	3510	4706	176	264	220	330
ATV6000C549A1414●●●	5490	4390	5887	220	264	3510	4706	176	264	220	330
ATV6000C625A1414●●●	6250	5000	6705	250	300	4470	5994	224	336	280	420
ATV6000C699A1414●●●	6990	5590	7496	280	336	4470	5994	224	336	280	420
ATV6000C799A1414●●●	7990	6390	8569	320	384	5110	6852	256	384	320	480
ATV6000C888A1414●●●	8880	7100	9521	355	426	6550	8783	328	492	410	615
ATV6000M103A1414●●●	10300	8190	10982	410	492	6550	8783	328	492	410	615
ATV6000M113A1414●●●	11300	9000	12069	450	540	7830	10500	392	588	490	735
ATV6000M123A1414●●●	12300	9790	13128	490	588	7830	10500	392	588	490	735
ATV6000M138A1414●●●	13800	10990	14737	550	660	8790	11787	440	660	550	825
ATV6000M150A1414●●●	15000	12000	16092	601	721	11500	15421	576	864	720	1080
ATV6000M165A1414●●●	16500	13200	17701	661	793	11500	15421	576	864	720	1080
ATV6000M180A1414●●●	18000	14380	19283	720	864	11500	15421	576	864	720	1080
ATV6000M189A1414●●●	18900	15100	20249	756	907	13580	18211	680	1020	850	1275
ATV6000M200A1414●●●	20000	16000	21456	801	961	13580	18211	680	1020	850	1275
ATV6000M212A1414●●●	21200	16900	22663	850	1020	13580	18211	680	1020	850	1275
ATV6000M232A1414●●●	23200	18500	24808	926	1111	15980	21429	800	1200	1000	1500

Power specifications for output voltage 13.8 kV, 33 power cells, 66 input pulses											
Model	Transformer rating (1)	Normal duty				Heavy duty				Power cell	
		Maximum motor shaft power (2)		Nominal continuous current	120% overload 1 min/10 mins	Maximum motor shaft power (2)		Nominal continuous current	150% overload 1 min/10 mins	Individual power cell rating	Max overload 3 sec/10 mins
	kVA	kW	HP	A	A	kW	HP	A	A	A	A
Voltage class: 13.8 kV (3)											
ATV6000M250A1414●●●	25000	20000	26820	1000	1200	15980	21429	800	1200	1000	1500
<p>(1) For higher drive power please contact Schneider Electric.</p> <p>(2) Values valid for synchronous motor and asynchronous motor. The specifications for the maximum motor shaft power is based on a motor efficiency of 95%, and power factor 0.88.</p> <p>(3) Please contact Schneider Electric for other combinations of input and output voltage.</p> <p>NOTE: For dimensions and outline drawings please refer to chapter Technical Data, page 50.</p>											

General Specification

General Technical Data

Input	18-48 pulse diode rectifier bridge
Output	Multilevel PWM with 2 level low-voltage IGBT inverter cells
Input voltage	<ul style="list-style-type: none"> 3.3 kV, 4.16 kV, 5.5 kV, 6.0 kV, 6.3 kV, 6.6 kV, 10 kV, 11 kV 2.4 kV and 13.8 kV on request Variation: $\pm 10\%$
Allowable voltage fluctuation	The drive is subject to derating operation when the voltage drop of power supply is within -20% .
Input frequency	50/60 Hz $\pm 5\%$
Incoming short circuit withstand	31.5 kA for 150 ms
Inrush current	<p>The Multilevel topology implies that the input transformer is designed with the primary coil at the inner side at the opposite of usual distribution transformers. For that reason, the inrush current has a higher amplitude but is shorter in time.</p> <p>Typical values for ATV6000 are $\hat{I}_{inrush} = [8 \text{ to } 14] \times \sqrt{2} \times I_{input_RMS}$ with a time constant limited to 80 to 120ms.</p> <p>The amplitude increases when the supply short circuit power increases or the transformer power rating increases. The time constant increases when the transformer power rating increases.</p>
Overload capability	<ul style="list-style-type: none"> Normal duty: 120 % 60 s/10 min and 150 % 3 s/10 min Heavy duty: 150 % 60 s/10 min, 185 % 3 s/10 min
Total harmonics THD(i)	Comply with the requirements of power quality standard of IEEE519-2014. (When supplied by balanced network without preexisting pollution. For more details please contact Schneider Electric.)
Input power factor	≥ 0.96 from 20 % to 100 % of load
Cable entry	Bottom (on request for others)
Frequency resolution	0.01 Hz
Power cells command signals transmission	Fiber optic transmission
Efficiency at rated power	Inverter efficiency is 98.5 %. Drive efficiency including input transformer is 96 % to 96.5 % depending on product.
Type of motor	Asynchronous motor, synchronous motor, permanent magnet motor (Surface / Interior magnet).
Three-phase output voltage for motor connection	0 to respective output voltage.
Output frequency	0.1 to 120 Hz
Input transformer	Indoor type integrated in the frequency variable device, the dry phase-shifting transformer can be supplied for 18-66 pulse rectifier
Control power supply	100...240 Vac $\pm 10\%$ (47...63 Hz), 1 kVA capacity. Other AC and DC voltage on request
Auxiliary power supply	230 Vac $\pm 10\%$, 50/60Hz, 1kVA capacity for standard configuration, value depending on auxiliary options used.
Cooling fan power supply	400 VAC $\pm 10\%$, 50Hz, capacity depending on drive reference. Other voltage on request
Communication protocols	Modbus TCP, EtherNet/IP, Modbus serial
HMI	10 inch, color graphic, touch screen, multi-languages
Control interface	8 DI, 3AI, 2AO, 3 relay output (more on request)
Degree of protection (cabinet)	<ul style="list-style-type: none"> Standard: IP31, IP22 air exhaust Option: IP41, IP42
Paint	RAL 7035

Panel thickness	2 mm
Cooling	Forced air ventilation
EMC	EN/IEC 61800-3 environment 2 category C4 for power, C3 for control
Reference standard	IEC EN 61800-3, IEC EN 61800-4, IEC EN 61800-5-1, IEC EN 60529, IEEE 519 and other optional ones C22.2 No.274-17 second edition.
Product certification	CE, EAC, CSA
Environment features	
Storage temperature	0 °C to 50 °C
Transportation temperature	-25 °C to 70 °C
Working temperature	0 to 40 °C, up to 50°C possible with derating (1).
Relative humidity	Up to 90% (without condensation) Optional: maximum up to 95% (without condensation)
Altitude	≤1000m, up to 2000m possible with derating. Above 2000m contact your local Schneider Electric representative.
Noise level	80/83/85 dB (A)
Over Voltage Category	IEC61800 (Adjustable speed electrical power drive systems - Part 5-1: Safety requirements - Electrical, thermal and energy)
<ul style="list-style-type: none"> • Drive line side • Drive motor side • Secures Control power supply • Auxiliary and fan power supply 	<ul style="list-style-type: none"> • Category III • Category II • Category II • Category III
Pollution in accordance with IEC 61800-5-1	Pollution degree 2
Environmental parameters (operation)	Refer to IEC60721-3-3
<ul style="list-style-type: none"> • Climatic conditions • Mechanical conditions • Biological conditions • Chemical conditions • Mechanically active substances 	<ul style="list-style-type: none"> • 3K3 • 3M1 • 3B1 • 3C2 • 3S1
(1): Derating must be applied on the drive system and the value of the derating is defined by Schneider Services depending on the customer application and the local environment conditions	

High Altitude

For drives to be installed from 2000 to 5000m, up to 4.16kV input/output is preferred. The drive size and maximum voltage (more than 4.16KV) are defined by Schneider Electric depending on the customer application and the local environmental conditions.

Options available up to 2000m only

- **Guarding options:**
 - Power cell bypass (**PC01**)
 - Inverter Redundancy N+1 (**PC02**)
- **Wiring:**
 - Analog isolator for one signal (**A13**)

NOTE: For all other options described in the chapter Options, page 245 contact your local Schneider Electric representative.

Master Controller Identification

Depending on the option chosen, there are two types of Master Controller. One linked to the **Power Output Enable (POE)** function and one linked to the **Safe Torque Off (STO)** function.

The sticker located on the Master Controller shows which function is used on your system.

ATV6000 MASTER CONTROLLER (POE)



The Power Output Enable (POE) function is managed during the commissioning, status of the POE function is displayed through HMI Panel.

Refer also to the I/O Interface diagram, page 48.

ATV6000 MASTER CONTROLLER (STO)



The Safe torque off (STO) function is managed during the commissioning, status of the STO function is displayed through HMI Panel.

Refer also to safety options, page 256 and the I/O Interface diagram, page 49.

ATV6000 Drive System I/O Interface Diagram

With Power Output Enable (POE) Configuration

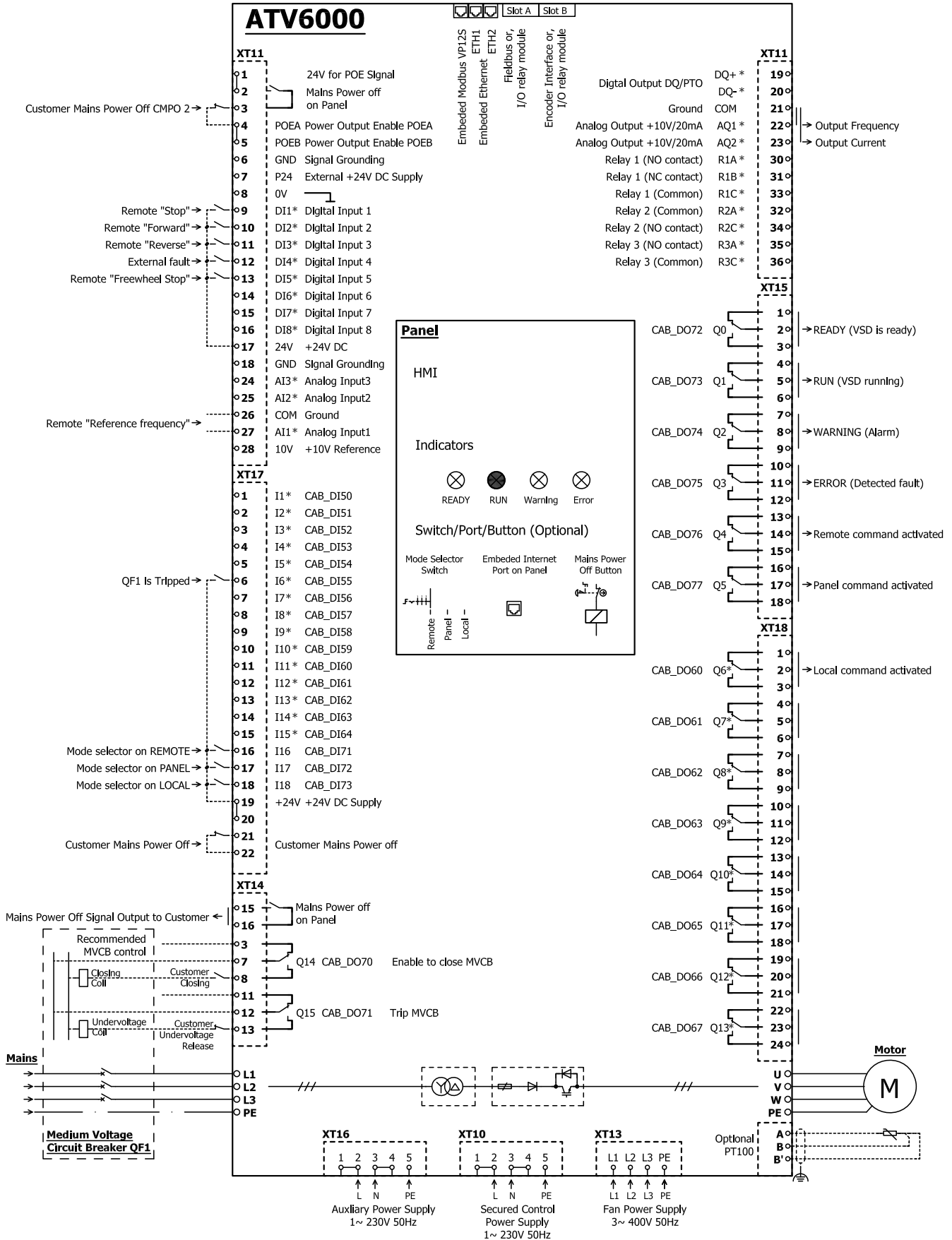

*Note: IO Function Configurable

With Safe Torque Off (STO) Configuration

NOTE: For all certified architecture refer to the ATV6000 Embedded Safety Function Manual BQT43422.

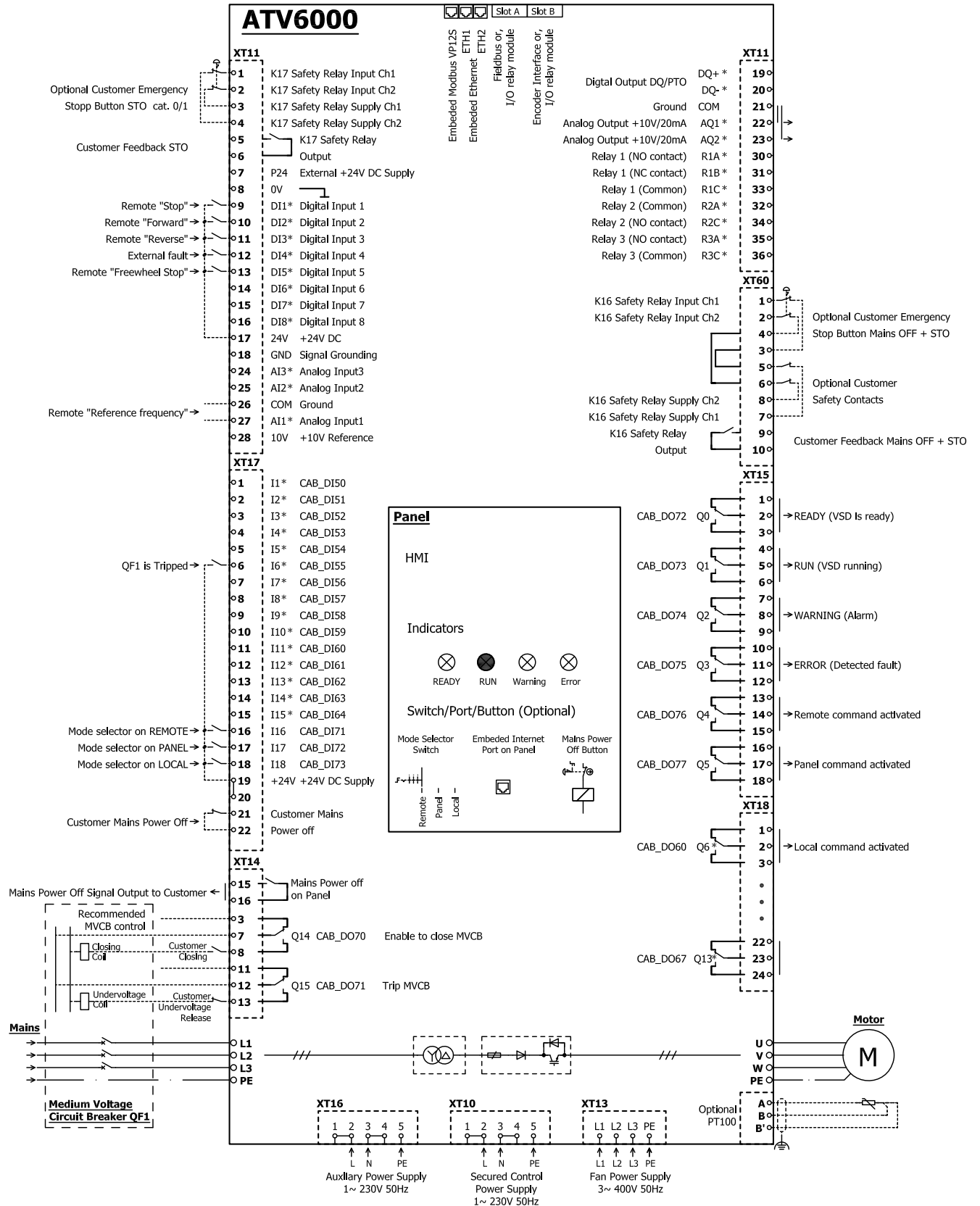

*Note: IO Function Configurable

Technical Data

Output Voltage 2.4 kV

ATV6000D200A2424...ATV6000D430A2424

ATV6000	D200A2424NA•		D280A2424NA•	
	Normal Duty	Heavy Duty	Normal Duty	Heavy Duty
Nominal data				
Type rating [kVA]	200		280	
Max. Motor power [kW] / [HP] 1)	160/214	150/201	220/295	180/241
Nominal Continuous output current [A] 1)	46	44	65	52
Max. output current with 120 % overload 1 min / 10 min [A]	55.2	/	78	/
Max. output current with 150 % overload 1 min / 10 min [A]	/	66	/	78
Power cells				
Number of cells per phase	3		3	
Power cell rated current [A]	65		65	
Power cell current with 120 % overload 1 min / 10 min [A]	78		78	
Max. output current for 3 sec [A]	97.5		97.5	
Characteristics with standard efficiency				
Efficiency at 100 % load (incl. Transformer) [%]	96.0%		96.0%	
Total losses at 100 % load [kW]	7.0	6.7	9.7	7.9
Air flow [m ³ /h]	7139		7139	
Noise level [dB (A)] @ 50 Hz	80		80	
Weight [kg / lb]	2589/5696		2688/5914	
Dimension [mm / inch] W*D*H 2)	2460*1400*2540/97*55.2*100.1		2460*1400*2540/97*55.2*100.1	
Connection				
Incoming cable type	symmetrical three-phase		symmetrical three-phase	
Typical cable size (mm ² / AWG) 3)	95/000		95/000	
Motor cable type	symmetrical three-phase(Use of shielded cable is advisable)		symmetrical three-phase(Use of shielded cable is advisable)	
Typical cable size (mm ² / AWG) 3)	25/4		25/4	
Motor cable Max. length 4)	3280 ft (1000 m)		3280 ft (1000 m)	
Grounding connection PE (mm ² / AWG)	50/0		50/0	
Control power supply	single phase, 230V, 50/60Hz		single phase, 230V, 50/60Hz	
Capacity of control power supply w/o options	1 kVA		1 kVA	
Capacity of control power supply with options	"depending on options to be used"		"depending on options to be used"	
Fan power supply	3-phase 400 Vac, 50Hz		3-phase 400 Vac, 50Hz	
Capacity of fan power supply (kVA) 5)	4		4	
Maintenance				
Maintenance access	Front		Front	
Cable entry 6)	Bottom in /Bottom out		Bottom in /Bottom out	

ATV6000	D350A2424NA●		D430A2424NA●	
	Normal Duty	Heavy Duty	Normal Duty	Heavy Duty
Nominal data				
Type rating [kVA]	350		430	
Max. Motor power [kW] / [HP] 1)	280/375	260/348	340/455	270/362
Nominal Continuous output current [A] 1)	80.6	77	100	80
Max. output current with 120 %overload 1 min / 10 min [A]	96.7	/	120	/
Max. output current with 150 % overload 1 min / 10 min [A]	/	116	/	120
Power cells				
Number of cells per phase	3		3	
Power cell rated current [A]	100		100	
Power cell current with 120 %overload 1 min / 10 min [A]	120		120	
Max. output current for 3 sec [A]	150		150	
Characteristics with standard efficiency				
Efficiency at 100 % load (incl. Transformer) [%]	96.0%		96.0%	
Total losses at 100 % load [kW]	12.2	11.4	14.9	11.8
Air flow [m³/h]	7139		7139	
Noise level [dB (A)] @ 50 Hz	80		80	
Weight [kg / lb]	2775/6105		2874/6323	
Dimension [mm / inch] W*D*H 2)	2460*1400*2540/97*55.2*100.1		2460*1400*2540/97*55.2*100.1	
Connection				
Incoming cable type	symmetrical three-phase		symmetrical three-phase	
Typical cable size (mm² / AWG) 3)	95/000		95/000	
Motor cable type	symmetrical three-phase(Use of shielded cable is advisable)		symmetrical three-phase(Use of shielded cable is advisable)	
Typical cable size (mm² / AWG) 3)	25/4		25/4	
Motor cable Max. length 4)	3280 ft (1000 m)		3280 ft (1000 m)	
Grounding connection PE (mm² / AWG)	50/0		50/0	
Control power supply	single phase, 230V, 50/60Hz		single phase, 230V, 50/60Hz	
Capacity of control power supply w/o options	1 kVA		1 kVA	
Capacity of control power supply with options	"depending on options to be used"		"depending on options to be used"	
Fan power supply	3-phase 400 Vac, 50Hz		3-phase 400 Vac, 50Hz	
Capacity of fan power supply (kVA) 5)	4		4	
Maintenance				
Maintenance access	Front		Front	
Cable entry 6)	Bottom in /Bottom out		Bottom in /Bottom out	
1) Values valid for synchronous motor and asynchronous motor. The specifications for the maximum motor shaft power is based on a motor efficiency of 95%. 2) Including the height of top cooling fans. 3) For CE products: Typical cable size values based on use of copper cables in cable tray laying. Incoming cable size is based on drive current rating. It has to be checked to be in accordance to mains short circuit capability and local and national electrical code requirement as well all other applicable regulations. 4) Variation in max. cable length may be possible depending on type cable and installation. For longer cable length between motor and drive contact Schneider Electric. 5) Contact Schneider Electric if N+1 redundancy cooling fan requested. 6) For other combination contact Schneider Electric.				

ATV6000D570A2424, ATV6000D650A2424

ATV6000	D570A2424NA●		D650A2424NA●	
Nominal data	Normal Duty	Heavy Duty	Normal Duty	Heavy Duty
Type rating [kVA]	570		650	
Max. Motor power [kW] / [HP] 1)	450/603	410/549	520/697	410/549
Nominal Continuous output current [A] 1)	130	120	150	120
Max. output current with 120 %overload 1 min / 10 min [A]	155	/	180	/
Max. output current with 150 % overload 1 min / 10 min [A]	/	180	/	180
Power cells				
Number of cells per phase	3		3	
Power cell rated current [A]	150		150	
Power cell current with 120 %overload 1 min / 10 min [A]	180		180	
Max. output current for 3 sec [A]	225		225	
Characteristics with standard efficiency				
Efficiency at 100 % load (incl. Transformer) [%]	96.0%		96.0%	
Total losses at 100 % load [kW]	19.7	17.9	22.7	17.9
Air flow [m ³ /h]	10934		10934	
Noise level [dB (A)] @ 50 Hz	80		80	
Weight [kg / lb]	3361/7394		3460/7612	
Dimension [mm / inch] W*D*H 2)	2760*1400*2645/ 108.8*55.2*104.3		2760*1400*2645/ 108.8*55.2*104.3	
Connection				
Incoming cable type	symmetrical three-phase		symmetrical three-phase	
Typical cable size (mm ² / AWG) 3)	95/000		95/000	
Motor cable type	symmetrical three-phase(Use of shielded cable is advisable)		symmetrical three-phase(Use of shielded cable is advisable)	
Typical cable size (mm ² / AWG) 3)	35/2		35/2	
Motor cable Max. length 4)	3280 ft (1000 m)		3280 ft (1000 m)	
Grounding connection PE (mm ² / AWG)	50/0		50/0	
Control power supply	single phase, 230V, 50/60Hz		single phase, 230V, 50/60Hz	
Capacity of control power supply w/o options	1 kVA		1 kVA	
Capacity of control power supply with options	"depending on options to be used"		"depending on options to be used"	
Fan power supply	3-phase 400 Vac, 50Hz		3-phase 400 Vac, 50Hz	
Capacity of fan power supply (kVA) 5)	7		7	
Maintenance				
Maintenance access	Front		Front	
Cable entry 6)	Bottom in /Bottom out		Bottom in /Bottom out	
<p>1) Values valid for synchronous motor and asynchronous motor. The specifications for the maximum motor shaft power is based on a motor efficiency of 95%.</p> <p>2) Including the height of top cooling fans.</p> <p>3) For CE products: Typical cable size values based on use of copper cables in cable tray laying. Incoming cable size is based on drive current rating. It has to be checked to be in accordance to mains short circuit capability and local and national electrical code requirement as well all other applicable regulations.</p> <p>4) Variation in max. cable length may be possible depending on type cable and installation. For longer cable length between motor and drive contact Schneider Electric.</p> <p>5) Contact Schneider Electric if N+1 redundancy cooling fan requested.</p> <p>6) For other combination contact Schneider Electric.</p>				

ATV6000D790A2424, ATV6000D950A2424

ATV6000	D790A2424NA●		D950A2424NA●	
	Normal Duty	Heavy Duty	Normal Duty	Heavy Duty
Nominal data				
Type rating [kVA]	790		950	
Max. Motor power [kW] / [HP] 1)	630/844	550/737	760/1019	610/818
Nominal Continuous output current [A] 1)	181	160	220	176
Max. output current with 120 %overload 1 min / 10 min [A]	218	/	264	/
Max. output current with 150 % overload 1 min / 10 min [A]	/	240	/	264
Power cells				
Number of cells per phase	3		3	
Power cell rated current [A]	200		220	
Power cell current with 120 %overload 1 min / 10 min [A]	240		264	
Max. output current for 3 sec [A]	300		330	
Characteristics with standard efficiency				
Efficiency at 100 % load (incl. Transformer) [%]	96.0%		96.0%	
Total losses at 100 % load [kW]	27.4	24.0	33.1	26.6
Air flow [m³/h]	12679		12679	
Noise level [dB (A)] @ 50 Hz	80		80	
Weight [kg / lb]	4155/9141		4353/9577	
Dimension [mm / inch] W*D*H 2)	3560*1400*2754/ 140.3*55.2*108.6		3560*1400*2754/ 140.3*55.2*108.6	
Connection				
Incoming cable type	symmetrical three-phase		symmetrical three-phase	
Typical cable size (mm² / AWG) 3)	95/000		95/000	
Motor cable type	symmetrical three-phase(Use of shielded cable is advisable)		symmetrical three-phase(Use of shielded cable is advisable)	
Typical cable size (mm² / AWG) 3)	50/0		70/00	
Motor cable Max. length 4)	3280 ft (1000 m)		3280 ft (1000 m)	
Grounding connection PE (mm² / AWG)	50/0		50/0	
Control power supply	single phase, 230V, 50/60Hz		single phase, 230V, 50/60Hz	
Capacity of control power supply w/o options	1 kVA		1 kVA	
Capacity of control power supply with options	"depending on options to be used"		"depending on options to be used"	
Fan power supply	3-phase 400 Vac, 50Hz		3-phase 400 Vac, 50Hz	
Capacity of fan power supply (kVA) 5)	5		5	
Maintenance				
Maintenance access	Front		Front	
Cable entry 6)	Bottom in /Bottom out		Bottom in /Bottom out	
1) Values valid for synchronous motor and asynchronous motor. The specifications for the maximum motor shaft power is based on a motor efficiency of 95%. 2) Including the height of top cooling fans. 3) For CE products: Typical cable size values based on use of copper cables in cable tray laying. Incoming cable size is based on drive current rating. It has to be checked to be in accordance to mains short circuit capability and local and national electrical code requirement as well all other applicable regulations. 4) Variation in max. cable length may be possible depending on type cable and installation. For longer cable length between motor and drive contact Schneider Electric. 5) Contact Schneider Electric if N+1 redundancy cooling fan requested. 6) For other combination contact Schneider Electric.				

ATV6000C122A2424

ATV6000	C122A2424NA●	
Nominal data	Normal Duty	Heavy Duty
Type rating [kVA]	1220	
Max. Motor power [kW] / [HP] 1)	970/1300	770/1032
Nominal Continuous output current [A] 1)	280	224
Max. output current with 120 %overload 1 min / 10 min [A]	336	/
Max. output current with 150 % overload 1 min / 10 min [A]	/	336
Power cells		
Number of cells per phase	3	
Power cell rated current [A]	280	
Power cell current with 120 %overload 1 min / 10 min [A]	336	
Max. output current for 3 sec [A]	420	
Characteristics with standard efficiency		
Efficiency at 100 % load (incl. Transformer) [%]	96.0%	
Total losses at 100 % load [kW]	42.2	33.5
Air flow [m ³ /h]	16620	
Noise level [dB (A)] @ 50 Hz	83	
Weight [kg / lb]	4751/10452	
Dimension [mm / inch] W*D*H 2)	3560*1500*2754/140.3*59.1*108.6	
Connection		
Incoming cable type	symmetrical three-phase	
Typical cable size (mm ² / AWG) 3)	95/000	
Motor cable type	symmetrical three-phase(Use of shielded cable is advisable)	
Typical cable size (mm ² / AWG) 3)	95/000	
Motor cable Max. length 4)	3280 ft (1000 m)	
Grounding connection PE (mm ² / AWG)	50/0	
Control power supply	single phase, 230V, 50/60Hz	
Capacity of control power supply w/o options	1 kVA	
Capacity of control power supply with options	"depending on options to be used"	
Fan power supply	3-phase 400 Vac, 50Hz	
Capacity of fan power supply (kVA) 5)	10	
Maintenance		
Maintenance access	Front	
Cable entry 6)	Bottom in /Bottom out	
<p>1) Values valid for synchronous motor and asynchronous motor. The specifications for the maximum motor shaft power is based on a motor efficiency of 95%.</p> <p>2) Including the height of top cooling fans.</p> <p>3) For CE products: Typical cable size values based on use of copper cables in cable tray laying. Incoming cable size is based on drive current rating. It has to be checked to be in accordance to mains short circuit capability and local and national electrical code requirement as well all other applicable regulations.</p> <p>4) Variation in max. cable length may be possible depending on type cable and installation. For longer cable length between motor and drive contact Schneider Electric.</p> <p>5) Contact Schneider Electric if N+1 redundancy cooling fan requested.</p> <p>6) For other combination contact Schneider Electric.</p>		

ATV6000C139A2424...ATV6000C178A2424

ATV6000	C139A2424NA●		C163A2424NA●	
Nominal data	Normal Duty	Heavy Duty	Normal Duty	Heavy Duty
Type rating [kVA]	1390		1630	
Max. Motor power [kW] / [HP] 1)	1100/1475	880/1180	1300/1743	1130/1515
Nominal Continuous output current [A] 1)	320	256	374	328
Max. output current with 120 %overload 1 min / 10 min [A]	384	/	449	/
Max. output current with 150 % overload 1 min / 10 min [A]	/	384	/	492
Power cells				
Number of cells per phase	3		3	
Power cell rated current [A]	320		410	
Power cell current with 120 %overload 1 min / 10 min [A]	384		492	
Max. output current for 3 sec [A]	480		615	
Characteristics with standard efficiency				
Efficiency at 100 % load (incl. Transformer) [%]	96.0%		96.0%	
Total losses at 100 % load [kW]	47.9	38.4	56.6	49.2
Air flow [m³/h]	15564		15564	
Noise level [dB (A)] @ 50 Hz	80		80	
Weight [kg / lb]	5933/13053		6231/13708	
Dimension [mm / inch] W*D*H 2)	4460*1500*2690/ 175.8*59.1*106		4460*1500*2690/ 175.8*59.1*106	
Connection				
Incoming cable type	symmetrical three-phase		symmetrical three-phase	
Typical cable size (mm² / AWG) 3)	120/0000		185/350MCM	
Motor cable type	symmetrical three-phase(Use of shielded cable is advisable)		symmetrical three-phase(Use of shielded cable is advisable)	
Typical cable size (mm² / AWG) 3)	120/0000		150/300MCM	
Motor cable Max. length 4)	3280 ft (1000 m)		3280 ft (1000 m)	
Grounding connection PE (mm² / AWG)	50/0		70/00	
Control power supply	single phase, 230V, 50/60Hz		single phase, 230V, 50/60Hz	
Capacity of control power supply w/o options	1 kVA		1 kVA	
Capacity of control power supply with options	"depending on options to be used"		"depending on options to be used"	
Fan power supply	3-phase 400 Vac, 50Hz		3-phase 400 Vac, 50Hz	
Capacity of fan power supply (kVA) 5)	7		7	
Maintenance				
Maintenance access	Front		Front	
Cable entry 6)	Bottom in /Bottom out		Bottom in /Bottom out	

ATV6000	C178A2424NA●	
Nominal data	Normal Duty	Heavy Duty
Type rating [kVA]	1780	
Max. Motor power [kW] / [HP] 1)	1420/1904	1130/1515
Nominal Continuous output current [A] 1)	410	328
Max. output current with 120 %overload 1 min / 10 min [A]	492	/
Max. output current with 150 % overload1 min / 10 min [A]	/	492
Power cells		
Number of cells per phase	3	
Power cell rated current [A]	410	
Power cell current with 120 %overload 1 min / 10 min [A]	492	
Max. output current for 3 sec [A]	615	
Characteristics with standard efficiency		
Efficiency at 100 % load (incl. Transformer) [%]	96.0%	
Total losses at 100 % load [kW]	61.8	49.2
Air flow [m ³ /h]	15564	
Noise level [dB (A)] @ 50 Hz	80	
Weight [kg / lb]	6416/14115	
Dimension [mm / inch] W*D*H 2)	4460*1500*2690/175.8*59.1*106	
Connection		
Incoming cable type	symmetrical three-phase	
Typical cable size (mm ² / AWG) 3)	185/350MCM	
Motor cable type	symmetrical three-phase(Use of shielded cable is advisable)	
Typical cable size (mm ² / AWG) 3)	185/350MCM	
Motor cable Max. length 4)	3280 ft (1000 m)	
Grounding connection PE (mm ² / AWG)	70/00	
Control power supply	single phase, 230V, 50/60Hz	
Capacity of control power supply w/o options	1 kVA	
Capacity of control power supply with options	"depending on options to be used"	
Fan power supply	3-phase 400 Vac, 50Hz	
Capacity of fan power supply (kVA) 5)	7	
Maintenance		
Maintenance access	Front	
Cable entry 6)	Bottom in /Bottom out	
<p>1) Values valid for synchronous motor and asynchronous motor. The specifications for the maximum motor shaft power is based on a motor efficiency of 95%.</p> <p>2) Including the height of top cooling fans.</p> <p>3) For CE products: Typical cable size values based on use of copper cables in cable tray laying. Incoming cable size is based on drive current rating. It has to be checked to be in accordance to mains short circuit capability and local and national electrical code requirement as well all other applicable regulations.</p> <p>4) Variation in max. cable length may be possible depending on type cable and installation. For longer cable length between motor and drive contact Schneider Electric.</p> <p>5) Contact Schneider Electric if N+1 redundancy cooling fan requested.</p> <p>6) For other combination contact Schneider Electric.</p>		

ATV6000C200A2424, ATV6000C213A2424

ATV6000	C200A2424NA●		C213A2424NA●	
Nominal data	Normal Duty	Heavy Duty	Normal Duty	Heavy Duty
Type rating [kVA]	2000		2130	
Max. Motor power [kW] / [HP] 1)	1600/2145	1360/1823	1700/2279	1360/1823
Nominal Continuous output current [A] 1)	460	392	490	392
Max. output current with 120 %overload 1 min / 10 min [A]	552	/	588	/
Max. output current with 150 % overload 1 min / 10 min [A]	/	588	/	588
Power cells				
Number of cells per phase	3		3	
Power cell rated current [A]	490		490	
Power cell current with 120 %overload 1 min / 10 min [A]	588		588	
Max. output current for 3 sec [A]	735		735	
Characteristics with standard efficiency				
Efficiency at 100 % load (incl. Transformer) [%]	96.0%		96.0%	
Total losses at 100 % load [kW]	69.6	59.2	73.9	59.2
Air flow [m³/h]	18120		18120	
Noise level [dB (A)] @ 50 Hz	80		80	
Weight [kg / lb]	6709/14760		6869/15112	
Dimension [mm / inch] W*D*H 2)	4460*1600*2754/ 175.8*63.1*108.6		4460*1600*2754/ 175.8*63.1*108.6	
Connection				
Incoming cable type	symmetrical three-phase		symmetrical three-phase	
Typical cable size (mm² / AWG) 3)	240/500MCM		95*2/2*000	
Motor cable type	symmetrical three-phase(Use of shielded cable is advisable)		symmetrical three-phase(Use of shielded cable is advisable)	
Typical cable size (mm² / AWG) 3)	240/500MCM		240/500MCM	
Motor cable Max. length 4)	3280 ft (1000 m)		3280 ft (1000 m)	
Grounding connection PE (mm² / AWG)	95/000		95/000	
Control power supply	single phase, 230V, 50/60Hz		single phase, 230V, 50/60Hz	
Capacity of control power supply w/o options	1 kVA		1 kVA	
Capacity of control power supply with options	"depending on options to be used"		"depending on options to be used"	
Fan power supply	3-phase 400 Vac, 50Hz		3-phase 400 Vac, 50Hz	
Capacity of fan power supply (kVA) 5)	9		9	
Maintenance				
Maintenance access	Front		Front	
Cable entry 6)	Bottom in /Bottom out		Bottom in /Bottom out	
1) Values valid for synchronous motor and asynchronous motor. The specifications for the maximum motor shaft power is based on a motor efficiency of 95%. 2) Including the height of top cooling fans. 3) For CE products: Typical cable size values based on use of copper cables in cable tray laying. Incoming cable size is based on drive current rating. It has to be checked to be in accordance to mains short circuit capability and local and national electrical code requirement as well all other applicable regulations. 4) Variation in max. cable length may be possible depending on type cable and installation. For longer cable length between motor and drive contact Schneider Electric. 5) Contact Schneider Electric if N+1 redundancy cooling fan requested. 6) For other combination contact Schneider Electric.				

ATV6000C225A2424...ATV6000C434A2424

ATV6000	C225A2424NA●		C239A2424NA●	
Nominal data	Normal Duty	Heavy Duty	Normal Duty	Heavy Duty
Type rating [kVA]	2250		2390	
Max. Motor power [kW] / [HP] 1)	1800/2413	1520/2038	1910/2561	1520/2038
Nominal Continuous output current [A] 1)	518	440	550	440
Max. output current with 120 %overload 1 min / 10 min [A]	622	/	660	/
Max. output current with 150 % overload 1 min / 10 min [A]	/	660	/	660
Power cells				
Number of cells per phase	3		3	
Power cell rated current [A]	550		550	
Power cell current with 120 %overload 1 min / 10 min [A]	660		660	
Max. output current for 3 sec [A]	825		825	
Characteristics with standard efficiency				
Efficiency at 100 % load (incl. Transformer) [%]	96.0%		96.0%	
Total losses at 100 % load [kW]	78.3	66.1	83.1	66.1
Air flow [m ³ /h]	30600		30600	
Noise level [dB (A)] @ 50 Hz	85		85	
Weight [kg / lb]	8689/19116		8862/19496	
Dimension [mm / inch] W*D*H 2)	5760*1700*2795/227*67*110.2		5760*1700*2795/227*67*110.2	
Connection				
Incoming cable type	symmetrical three-phase		symmetrical three-phase	
Typical cable size (mm ² / AWG) 3)	95*2/2*000		95*2/2*000	
Motor cable type	symmetrical three-phase(Use of shielded cable is advisable)		symmetrical three-phase(Use of shielded cable is advisable)	
Typical cable size (mm ² / AWG) 3)	95*2/2*000		95*2/2*000	
Motor cable Max. length 4)	1000 m		1000 m	
Grounding connection PE (mm ² / AWG)	95/000		95/000	
Control power supply	single phase, 230V, 50/60Hz,		single phase, 230V, 50/60Hz,	
Capacity of control power supply w/o options	1 kVA		1 kVA	
Capacity of control power supply with options	"depending on options to be used"		"depending on options to be used"	
Fan power supply	3-phase 400 Vac, 50Hz		3-phase 400 Vac, 50Hz	
Capacity of fan power supply (kVA) 5)	25		25	
Maintenance				
Maintenance access	Front		Front	
Cable entry 6)	Bottom in /Bottom out		Bottom in /Bottom out	

ATV6000	C275A2424NA●		C313A2424NA●	
	Normal Duty	Heavy Duty	Normal Duty	Heavy Duty
Nominal data				
Type rating [kVA]	2750		3130	
Max. Motor power [kW] / [HP] 1)	2200/2950	2000/2682	2500/3352	2000/2682
Nominal Continuous output current [A] 1)	633	576	720	576
Max. output current with 120 %overload 1 min / 10 min [A]	760	/	864	/
Max. output current with 150 % overload 1 min / 10 min [A]	/	864	/	864
Power cells				
Number of cells per phase	3		3	
Power cell rated current [A]	720		720	
Power cell current with 120 %overload 1 min / 10 min [A]	864		864	
Max. output current for 3 sec [A]	1080		1080	
Characteristics with standard efficiency				
Efficiency at 100 % load (incl. Transformer) [%]	96.0%		96.0%	
Total losses at 100 % load [kW]	95.6	87.0	108.7	87.0
Air flow [m³/h]	30600		30600	
Noise level [dB (A)] @ 50 Hz	85		85	
Weight [kg / lb]	9308/20478		9778/21512	
Dimension [mm / inch] W*D*H 2)	5760*1700*2795/227*67*110.2		5760*1700*2795/227*67*110.2	
Connection				
Incoming cable type	symmetrical three-phase		symmetrical three-phase	
Typical cable size (mm² / AWG) 3)	120*2/2*0000		150*2/2*300MCM	
Motor cable type	symmetrical three-phase(Use of shielded cable is advisable)		symmetrical three-phase(Use of shielded cable is advisable)	
Typical cable size (mm² / AWG) 3)	120*2/2*0000		150*2/2*300MCM	
Motor cable Max. length 4)	1000 m		1000 m	
Grounding connection PE (mm² / AWG)	120/0000		120/0000	
Control power supply	single phase, 230V, 50/60Hz,		single phase, 230V, 50/60Hz,	
Capacity of control power supply w/o options	1 kVA		1 kVA	
Capacity of control power supply with options	"depending on options to be used"		"depending on options to be used"	
Fan power supply	3-phase 400 Vac, 50Hz		3-phase 400 Vac, 50Hz	
Capacity of fan power supply (kVA) 5)	25		25	
Maintenance				
Maintenance access	Front		Front	
Cable entry 6)	Bottom in /Bottom out		Bottom in /Bottom out	

ATV6000	C338A2424NA●		C369A2424NA●	
Nominal data	Normal Duty	Heavy Duty	Normal Duty	Heavy Duty
Type rating [kVA]	3380		3690	
Max. Motor power [kW] / [HP] 1)	2700/3620	2360/3164	2950/3956	2360/3164
Nominal Continuous output current [A] 1)	777	680	850	680
Max. output current with 120 % overload 1 min / 10 min [A]	932	/	1020	/
Max. output current with 150 % overload 1 min / 10 min [A]	/	1020	/	1020
Power cells				
Number of cells per phase	3		3	
Power cell rated current [A]	850		850	
Power cell current with 120 % overload 1 min / 10 min [A]	1020		1020	
Max. output current for 3 sec [A]	1275		1275	
Characteristics with standard efficiency				
Efficiency at 100 % load (incl. Transformer) [%]	96.0%		96.0%	
Total losses at 100 % load [kW]	117.3	102.6	128.2	102.6
Air flow [m ³ /h]	31944		31944	
Noise level [dB (A)] @ 50 Hz	85		85	
Weight [kg / lb]	10150/22330		10534/23175	
Dimension [mm / inch] W*D*H 2)	5760*1700*2795/227*67*110.2		5760*1700*2795/227*67*110.2	
Connection				
Incoming cable type	symmetrical three-phase		symmetrical three-phase	
Typical cable size (mm ² / AWG) 3)	185*2/2*350MCM		240*2/2*500MCM	
Motor cable type	symmetrical three-phase(Use of shielded cable is advisable)		symmetrical three-phase(Use of shielded cable is advisable)	
Typical cable size (mm ² / AWG) 3)	240*2/2*500MCM		240*2/2*500MCM	
Motor cable Max. length 4)	1000 m		1000 m	
Grounding connection PE (mm ² / AWG)	150/300MCM		150/300MCM	
Control power supply	single phase, 230V, 50/60Hz,		single phase, 230V, 50/60Hz,	
Capacity of control power supply w/o options	1 kVA		1 kVA	
Capacity of control power supply with options	"depending on options to be used"		"depending on options to be used"	
Fan power supply	3-phase 400 Vac, 50Hz		3-phase 400 Vac, 50Hz	
Capacity of fan power supply (kVA) 5)	29		29	
Maintenance				
Maintenance access	Front		Front	
Cable entry 6)	Bottom in /Bottom out		Bottom in /Bottom out	

ATV6000	C400A2424NA●		C434A2424NA●	
	Normal Duty	Heavy Duty	Normal Duty	Heavy Duty
Nominal data				
Type rating [kVA]	4000		4340	
Max. Motor power [kW] / [HP] 1)	3200/4291	2780/3728	3470/4653	2780/3728
Nominal Continuous output current [A] 1)	921	800	1000	800
Max. output current with 120 %overload 1 min / 10 min [A]	1105	/	1200	/
Max. output current with 150 % overload 1 min / 10 min [A]	/	1200	/	1200
Power cells				
Number of cells per phase	3		3	
Power cell rated current [A]	1000		1000	
Power cell current with 120 %overload 1 min / 10 min [A]	1200		1200	
Max. output current for 3 sec [A]	1500		1500	
Characteristics with standard efficiency				
Efficiency at 100 % load (incl. Transformer) [%]	96.0%		96.0%	
Total losses at 100 % load [kW]	139.0	120.8	150.8	120.8
Air flow [m³/h]	31944		31944	
Noise level [dB (A)] @ 50 Hz	85		85	
Weight [kg / lb]	10988/24174		11409/25100	
Dimension [mm / inch] W*D*H 2)	5760*1700*2795/227*67*110.2		5760*1700*2795/227*67*110.2	
Connection				
Incoming cable type	symmetrical three-phase		symmetrical three-phase	
Typical cable size (mm² / AWG) 3)	240*2/2*500MCM		120*3/3*0000	
Motor cable type	symmetrical three-phase(Use of shielded cable is advisable)		symmetrical three-phase(Use of shielded cable is advisable)	
Typical cable size (mm² / AWG) 3)	240*2/2*500MCM		240*2/2*500MCM	
Motor cable Max. length 4)	1000 m		1000 m	
Grounding connection PE (mm² / AWG)	240/500MCM		240/500MCM	
Control power supply	single phase, 230V, 50/60Hz,		single phase, 230V, 50/60Hz,	
Capacity of control power supply w/o options	1 kVA		1 kVA	
Capacity of control power supply with options	"depending on options to be used"		"depending on options to be used"	
Fan power supply	3-phase 400 Vac, 50Hz		3-phase 400 Vac, 50Hz	
Capacity of fan power supply (kVA) 5)	29		29	
Maintenance				
Maintenance access	Front		Front	
Cable entry 6)	Bottom in /Bottom out		Bottom in /Bottom out	
1) Values valid for synchronous motor and asynchronous motor. The specifications for the maximum motor shaft power is based on a motor efficiency of 95%. 2) Including the height of top cooling fans. 3) For CE products: Typical cable size values based on use of copper cables in cable tray laying. Incoming cable size is based on drive current rating. It has to be checked to be in accordance to mains short circuit capability and local and national electrical code requirement as well all other applicable regulations. 4) Variation in max. cable length may be possible depending on type cable and installation. For longer cable length between motor and drive contact Schneider Electric. 5) Contact Schneider Electric if N+1 redundancy cooling fan requested. 6) For other combination contact Schneider Electric.				

Layout Drawing and Dimensions

Layout Drawing

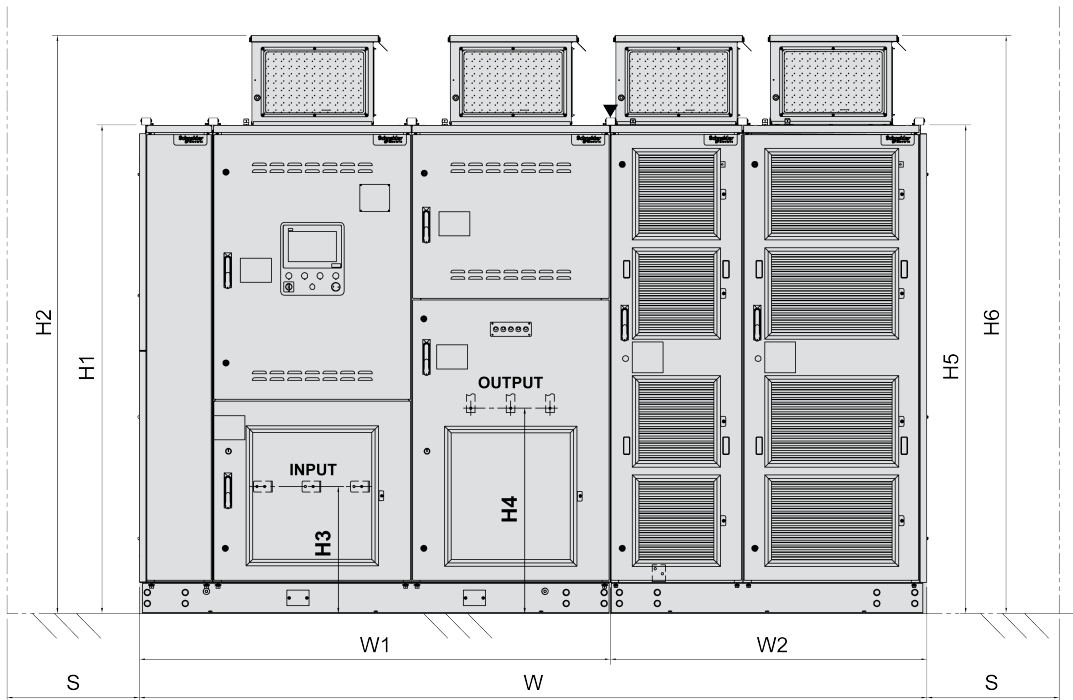

INPUT: Input terminal

OUTPUT: Output terminal

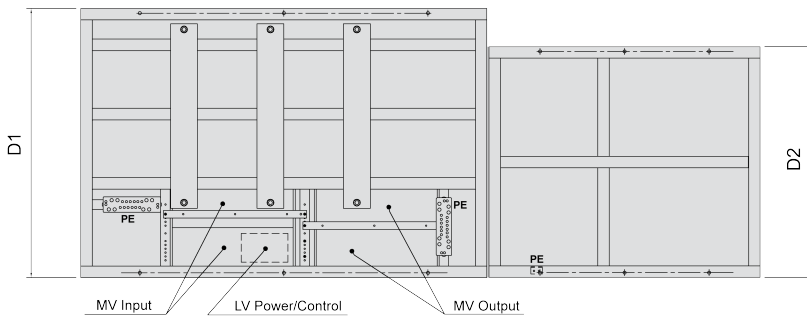

MV Input: MV Input cable area

LV Power/Control: LV Power/Control cable area

MV Output: MV Output cable area

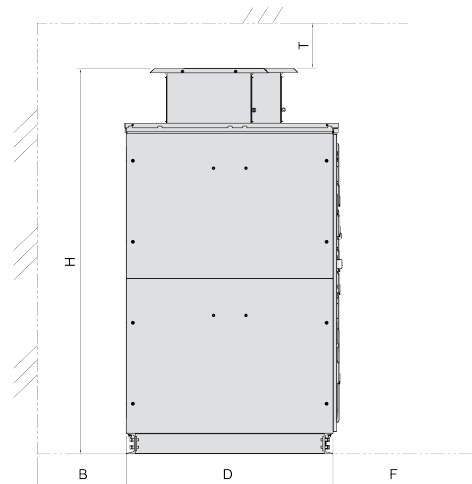

NOTE: Sketch is representing outline dimensions only, real cabinet arrangement is depending on power size.

Main dimensions - Output Voltage 2.4 kV

Product reference	Outer dimensions (mm / in)			Transformer cabinet			Powercell cabinet		
	W	H ^(b)	D	Fan Type	Fan Number	Weight [kg / lb]	Fan Type	Fan number	Weight [kg / lb]
ATV6000D200A2424***	2460	2540	1400	400	2	1981.8	400	1	606.5
	97	100	55			4360			1213
ATV6000D280A2424***	2460	2540	1400	400	2	2080.9	400	1	606.5
	97	100	55			4578			1213
ATV6000D350A2424***	2460	2540	1400	400	2	2167.6	400	1	606.5
	97	100	55			4768.7			1213
ATV6000D430A2424***	2460	2540	1400	400	2	2266.6	400	1	606.5
	97	100	55			4986.5			1213
ATV6000D570A2424***	2760	2645	1400	400	2	2439.9	560	1	920.2
	109	104	55			5367.8			1840.4
ATV6000D650A2424***	2760	2645	1400	400	2	2539	560	1	920.2
	109	104	55			5585.8			1840.4
ATV6000D790A2424***	3560	2754	1400	450	2	2862.7	400	2	1292
	140	108	55			6297.9			2584
ATV6000D950A2424***	3560	2754	1400	450	2	3060.8	400	2	1292
	140	108	55			6733.8			2584
ATV6000C122A2424***	3560	2754	1500	450	2	3430.4	500	2	1320.2
	140	108	59			7546.9			2640.4
ATV6000C139A2424***	4460	2690	1500	400	3	3770.8	400	3	2162.2
	176	106	59			8295.8			4324.4
ATV6000C163A2424***	4460	2690	1500	400	3	4067.9	400	3	2162.2
	176	106	59			8949.4			4324.4
ATV6000C178A2424***	4460	2690	1500	400	3	4253.6	400	3	2162.2
	176	106	59			9357.9			4324.4
ATV6000C200A2424***	4460	2754	1600	450	3	4556.3	450	3	2151.7
	176	108	63			10023.9			4303.3
ATV6000C213A2424***	4460	2754	1600	450	3	4717.3	450	3	2151.7
	176	108	63			10378.1			4303.3
ATV6000C225A2424***	5760	2795	1700	560	3	5034	500	3	3654.4
	227	110	67			11074.8			7308.9
ATV6000C239A2424***	5760	2795	1700	560	3	5207.3	500	3	3654.4
	227	110	67			11456.1			7308.9
ATV6000C275A2424***	5760	2795	1700	560	3	5653	500	3	3654.4
	227	110	67			12436.6			7308.9
ATV6000C313A2424***	5760	2795	1700	560	3	6123.5	500	3	3654.4
	227	110	67			13471.7			7308.9
ATV6000C338A2424***	5760	2795	1700	560	3	6433	560	3	3716.2
	227	110	67			14152.6			7432.5
ATV6000C369A2424***	5760	2795	1700	560	3	6816.8	560	3	3716.2
	227	110	67			14997			7432.5

Product reference	Outer dimensions (mm / in)			Transformer cabinet			Powercell cabinet		
	W	H ^(b)	D	Fan Type	Fan Number	Weight [kg / lb]	Fan Type	Fan number	Weight [kg / lb]
ATV6000C400A2424...	5760	2795	1700	560	3	7189.5	560	3	3798.3
	227	110	67			15816.9			7596.6
ATV6000C434A2424...	5760	2795	1700	560	3	7610.5	560	3	3798.3
	227	110	67			16743.1			7596.6

a) "H" is linked to higher size of transformer cabinet (H2) or power cell cabinet (H6).

Additional Dimensions - Output Voltage 2.4 kV

Product reference	Transformer Cabinet						Power cell Cabinet				Space Maintenance			
	(mm / in)						(mm / in)				(mm / in)			
	H1	H2	H3	H4	W1	D1	H5	H6	W2	D2	T	B (a)	F (b)	S (c)
ATV6000D200A2424***	2210	2540	500	780	1830	1400	2210	2540	630	1200	≥500	0	1500	0
	87	100	20	31	72	55	87	100	25	47	≥20		59	
ATV6000D280A2424***	2210	2540	500	780	1830	1400	2210	2540	630	1200	≥500	0	1500	0
	87	100	20	31	72	55	87	100	25	47	≥20		59	
ATV6000D350A2424***	2210	2540	500	780	1830	1400	2210	2540	630	1200	≥500	0	1500	0
	87	100	20	31	72	55	87	100	25	47	≥20		59	
ATV6000D430A2424***	2210	2540	500	780	1830	1400	2210	2540	630	1200	≥500	0	1500	0
	87	100	20	31	72	55	87	100	25	47	≥20		59	
ATV6000D570A2424***	2210	2540	500	780	1830	1400	2210	2645	930	1200	≥500	0	1500	0
	87	100	20	31	72	55	87	104	37	47	≥20		59	
ATV6000D650A2424***	2210	2540	500	780	1830	1400	2210	2645	930	1200	≥500	0	1500	0
	87	100	20	31	72	55	87	104	37	47	≥20		59	
ATV6000D790A2424***	2360	2754	500	930	2130	1400	2210	2540	1430	1200	≥500	0	1500	0
	93	108	20	37	84	55	87	100	56	47	≥20		59	
ATV6000D950A2424***	2360	2754	500	930	2130	1400	2210	2540	1430	1200	≥500	0	1500	0
	93	108	20	37	84	55	87	100	56	47	≥20		59	
ATV6000C122A2424***	2360	2754	500	930	2130	1500	2210	2618	1430	1200	≥500	0	1500	0
	93	108	20	37	84	59	87	103	56	47	≥20		59	
ATV6000C139A2424***	2360	2690	500	930	2430	1500	2360	2690	2030	1200	≥500	0	1500	0
	93	106	20	37	96	59	93	106	80	47	≥20		59	
ATV6000C163A2424***	2360	2690	500	930	2430	1500	2360	2690	2030	1200	≥500	0	1500	0
	93	106	20	37	96	59	93	106	80	47	≥20		59	
ATV6000C178A2424***	2360	2690	500	930	2430	1500	2360	2690	2030	1200	≥500	0	1500	0
	93	106	20	37	96	59	93	106	80	47	≥20		59	
ATV6000C200A2424***	2360	2754	500	930	2430	1600	2360	2754	2030	1200	≥500	0	1500	0
	93	108	20	37	96	63	93	108	80	47	≥20		59	
ATV6000C213A2424***	2360	2754	500	930	2430	1600	2360	2754	2030	1200	≥500	0	1500	0
	93	108	20	37	96	63	93	108	80	47	≥20		59	
ATV6000C225A2424***	2360	2795	500	930	2730	1700	2360	2768	3030	1400	≥500	0	1500	0
	93	110	20	37	107	67	93	109	119	55	≥20		59	
ATV6000C239A2424***	2360	2795	500	930	2730	1700	2360	2768	3030	1400	≥500	0	1500	0
	93	110	20	37	107	67	93	109	119	55	≥20		59	
ATV6000C275A2424***	2360	2795	500	930	2730	1700	2360	2768	3030	1400	≥500	0	1500	0
	93	110	20	37	107	67	93	109	119	55	≥20		59	
ATV6000C313A2424***	2360	2795	500	930	2730	1700	2360	2768	3030	1400	≥500	0	1500	0
	93	110	20	37	107	67	93	109	119	55	≥20		59	
ATV6000C338A2424***	2360	2795	500	930	2730	1700	2360	2795	3030	1400	≥500	0	1500	0
	93	110	20	37	107	67	93	110	119	55	≥20		59	
ATV6000C369A2424***	2360	2795	500	930	2730	1700	2360	2795	3030	1400	≥500	0	1500	0
	93	110	20	37	107	67	93	110	119	55	≥20		59	

Product reference	Transformer Cabinet (mm / in)						Power cell Cabinet (mm / in)				Space Maintenance (mm / in)			
	H1	H2	H3	H4	W1	D1	H5	H6	W2	D2	T	B (a)	F (b)	S(c)
ATV6000C400A2424...	2360	2795	500	930	2730	1700	2360	2795	3030	1600	≥500	0	1500	0
	93	110	20	37	107	67	93	110	119	63	≥20	0	59	0
ATV6000C434A2424...	2360	2795	500	930	2730	1700	2360	2795	3030	1600	≥500	0	1500	0
	93	110	20	37	107	67	93	110	119	63	≥20	0	59	0

a) Space could be required for installation and lifting lugs.
b) For easy handling with power cell exchange tool 2000mm (78.7 in) are recommended.
c) Space (600mm) could be required for maintenance of the front & rear access drive.

Output Voltage 3.3 kV

ATV6000D390A3333...ATV6000D590A3333

ATV6000	D390A3333NA●		D500A3333NA●	
	Normal Duty	Heavy Duty	Normal Duty	Heavy Duty
Nominal data				
Type rating [kVA]	390		500	
Max. Motor power [kW] / [HP] 1)	310/415	240/321	400/536	380/509
Nominal Continuous output current [A] 1)	65	52	83.7	80
Max. output current with 120 %overload 1 min / 10 min [A]	78	/	100	/
Max. output current with 150 % overload 1 min / 10 min [A]	/	78	/	120
Power cells				
Number of cells per phase	3		3	
Power cell rated current [A]	65		100	
Power cell current with 120 %overload 1 min / 10 min [A]	78		120	
Max. output current for 3 sec [A]	97.5		150	
Characteristics with standard efficiency				
Efficiency at 100 % load (incl. Transformer) [%]	96.0%		96.0%	
Total losses at 100 % load [kW]	13.5	10.5	17.5	16.6
Air flow [m³/h]	7139		7139	
Noise level [dB (A)] @ 50 Hz	80		80	
Weight [kg / lb]	2824/6213		2960/6512	
Dimension [mm / inch] W*D*H 2)	2460*1400*2540/97*55.2*100.1		2460*1400*2540/97*55.2*100.1	
Connection				
Incoming cable type	symmetrical three-phase		symmetrical three-phase	
Typical cable size (mm² / AWG) 3)	95/000		95/000	
Motor cable type	symmetrical three-phase(Use of shielded cable is advisable)		symmetrical three-phase(Use of shielded cable is advisable)	
Typical cable size (mm² / AWG) 3)	25/4		25/4	
Motor cable Max. length 4)	1000 m		1000 m	
Grounding connection PE (mm² / AWG)	50/0		50/0	
Control power supply	single phase, 230V, 50/60Hz,		single phase, 230V, 50/60Hz,	
Capacity of control power supply w/o options	1 kVA		1 kVA	
Capacity of control power supply with options	"depending on options to be used"		"depending on options to be used"	
Fan power supply	3-phase 400 Vac, 50Hz		3-phase 400 Vac, 50Hz	
Capacity of fan power supply (kVA) 5)	4		4	
Maintenance				
Maintenance access	Front		Front	
Cable entry 6)	Bottom in /Bottom out		Bottom in /Bottom out	

ATV6000	D590A3333NA●	
Nominal data	Normal Duty	Heavy Duty
Type rating [kVA]	590	
Max. Motor power [kW] / [HP] 1)	470/630	380/509
Nominal Continuous output current [A] 1)	100	80
Max. output current with 120 %overload 1 min / 10 min [A]	120	/
Max. output current with 150 % overload1 min / 10 min [A]	/	120
Power cells		
Number of cells per phase	3	
Power cell rated current [A]	100	
Power cell current with 120 %overload 1 min / 10 min [A]	120	
Max. output current for 3 sec [A]	150	
Characteristics with standard efficiency		
Efficiency at 100 % load (incl. Transformer) [%]	96.0%	
Total losses at 100 % load [kW]	20.5	16.6
Air flow [m ³ /h]	7139	
Noise level [dB (A)] @ 50 Hz	80	
Weight [kg / lb]	3072/6758	
Dimension [mm / inch] W*D*H 2)	2460*1400*2540/97*55.2*100.1	
Connection		
Incoming cable type	symmetrical three-phase	
Typical cable size (mm ² / AWG) 3)	95/000	
Motor cable type	symmetrical three-phase(Use of shielded cable is advisable)	
Typical cable size (mm ² / AWG) 3)	25/4	
Motor cable Max. length 4)	1000 m	
Grounding connection PE (mm ² / AWG)	50/0	
Control power supply	single phase, 230V, 50/60Hz,	
Capacity of control power supply w/o options	1 kVA	
Capacity of control power supply with options	"depending on options to be used"	
Fan power supply	3-phase 400 Vac, 50Hz	
Capacity of fan power supply (kVA) 5)	4	
Maintenance		
Maintenance access	Front	
Cable entry 6)	Bottom in /Bottom out	
<p>1) Values valid for synchronous motor and asynchronous motor. The specifications for the maximum motor shaft power is based on a motor efficiency of 95%.</p> <p>2) Including the height of top cooling fans.</p> <p>3) For CE products: Typical cable size values based on use of copper cables in cable tray laying. Incoming cable size is based on drive current rating. It has to be checked to be in accordance to mains short circuit capability and local and national electrical code requirement as well all other applicable regulations.</p> <p>4) Variation in max. cable length may be possible depending on type cable and installation. For longer cable length between motor and drive contact Schneider Electric.</p> <p>5) Contact Schneider Electric if N+1 redundancy cooling fan requested.</p> <p>6) For other combination contact Schneider Electric.</p>		

ATV6000D700A3333...ATV6000D890A3333

ATV6000	D700A3333NA●		D790A3333NA●	
	Normal Duty	Heavy Duty	Normal Duty	Heavy Duty
Nominal data				
Type rating [kVA]	700		790	
Max. Motor power [kW] / [HP] 1)	560/750	530/710	630/844	570/764
Nominal Continuous output current [A] 1)	117	112	132	120
Max. output current with 120 %overload 1 min / 10 min [A]	141	/	158	/
Max. output current with 150 % overload1 min / 10 min [A]	/	168	/	180
Power cells				
Number of cells per phase	3		3	
Power cell rated current [A]	150		150	
Power cell current with 120 %overload 1 min / 10 min [A]	180		180	
Max. output current for 3 sec [A]	225		225	
Characteristics with standard efficiency				
Efficiency at 100 % load (incl. Transformer) [%]	96.0%		96.0%	
Total losses at 100 % load [kW]	24.4	23.1	27.4	24.9
Air flow [m³/h]	10934		10934	
Noise level [dB (A)] @ 50 Hz	80		80	
Weight [kg / lb]	3522/7748		3633/7993	
Dimension [mm / inch] W*D*H 2)	2760*1400*2645/ 108.8*55.2*104.3		2760*1400*2645/ 108.8*55.2*104.3	
Connection				
Incoming cable type	symmetrical three-phase		symmetrical three-phase	
Typical cable size (mm² / AWG) 3)	95/000		95/000	
Motor cable type	symmetrical three-phase(Use of shielded cable is advisable)		symmetrical three-phase(Use of shielded cable is advisable)	
Typical cable size (mm² / AWG) 3)	35/2		35/2	
Motor cable Max. length 4)	1000 m		1000 m	
Grounding connection PE (mm² / AWG)	50/0		50/0	
Control power supply	single phase, 230V, 50/60Hz,		single phase, 230V, 50/60Hz,	
Capacity of control power supply w/o options	1 kVA		1 kVA	
Capacity of control power supply with options	"depending on options to be used"		"depending on options to be used"	
Fan power supply	3-phase 400 Vac, 50Hz		3-phase 400 Vac, 50Hz	
Capacity of fan power supply (kVA) 5)	7		7	
Maintenance				
Maintenance access	Front		Front	
Cable entry 6)	Bottom in /Bottom out		Bottom in /Bottom out	

ATV6000	D890A3333NA●	
Nominal data	Normal Duty	Heavy Duty
Type rating [kVA]	890	
Max. Motor power [kW] / [HP] 1)	710/952	570/764
Nominal Continuous output current [A] 1)	150	120
Max. output current with 120 %overload 1 min / 10 min [A]	180	/
Max. output current with 150 % overload1 min / 10 min [A]	/	180
Power cells		
Number of cells per phase	3	
Power cell rated current [A]	150	
Power cell current with 120 %overload 1 min / 10 min [A]	180	
Max. output current for 3 sec [A]	225	
Characteristics with standard efficiency		
Efficiency at 100 % load (incl. Transformer) [%]	96.0%	
Total losses at 100 % load [kW]	30.9	24.9
Air flow [m ³ /h]	10934	
Noise level [dB (A)] @ 50 Hz	80	
Weight [kg / lb]	3757/8265	
Dimension [mm / inch] W*D*H 2)	2760*1400*2645/108.8*55.2*104.3	
Connection		
Incoming cable type	symmetrical three-phase	
Typical cable size (mm ² / AWG) 3)	95/000	
Motor cable type	symmetrical three-phase(Use of shielded cable is advisable)	
Typical cable size (mm ² / AWG) 3)	35/2	
Motor cable Max. length 4)	1000 m	
Grounding connection PE (mm ² / AWG)	50/0	
Control power supply	single phase, 230V, 50/60Hz,	
Capacity of control power supply w/o options	1 kVA	
Capacity of control power supply with options	"depending on options to be used"	
Fan power supply	3-phase 400 Vac, 50Hz	
Capacity of fan power supply (kVA) 5)	7	
Maintenance		
Maintenance access	Front	
Cable entry 6)	Bottom in /Bottom out	
<p>1) Values valid for synchronous motor and asynchronous motor. The specifications for the maximum motor shaft power is based on a motor efficiency of 95%.</p> <p>2) Including the height of top cooling fans.</p> <p>3) For CE products: Typical cable size values based on use of copper cables in cable tray laying. Incoming cable size is based on drive current rating. It has to be checked to be in accordance to mains short circuit capability and local and national electrical code requirement as well all other applicable regulations.</p> <p>4) Variation in max. cable length may be possible depending on type cable and installation. For longer cable length between motor and drive contact Schneider Electric.</p> <p>5) Contact Schneider Electric if N+1 redundancy cooling fan requested.</p> <p>6) For other combination contact Schneider Electric.</p>		

ATV6000C100A3333...ATV6000C132A3333

ATV6000	C100A3333NA●		C113A3333NA●	
Nominal data	Normal Duty	Heavy Duty	Normal Duty	Heavy Duty
Type rating [kVA]	1000		1130	
Max. Motor power [kW] / [HP] 1)	800/1072	760/1019	900/1206	760/1019
Nominal Continuous output current [A] 1)	167	160	188	160
Max. output current with 120 %overload 1 min / 10 min [A]	201	/	226	/
Max. output current with 150 % overload 1 min / 10 min [A]	/	240	/	240
Power cells				
Number of cells per phase	3		3	
Power cell rated current [A]	200		200	
Power cell current with 120 %overload 1 min / 10 min [A]	240		240	
Max. output current for 3 sec [A]	300		300	
Characteristics with standard efficiency				
Efficiency at 100 % load (incl. Transformer) [%]	96.0%		96.0%	
Total losses at 100 % load [kW]	34.9	33.1	39.2	33.1
Air flow [m³/h]	12679		12679	
Noise level [dB (A)] @ 50 Hz	80		80	
Weight [kg / lb]	4415/9713		4576/10067	
Dimension [mm / inch] W*D*H 2)	3560*1400*2754/ 140.3*55.2*108.6		3560*1400*2754/ 140.3*55.2*108.6	
Connection				
Incoming cable type	symmetrical three-phase		symmetrical three-phase	
Typical cable size (mm² / AWG) 3)	95/000		95/000	
Motor cable type	symmetrical three-phase(Use of shielded cable is advisable)		symmetrical three-phase(Use of shielded cable is advisable)	
Typical cable size (mm² / AWG) 3)	35/2		50/0	
Motor cable Max. length 4)	1000 m		1000 m	
Grounding connection PE (mm² / AWG)	50/0		50/0	
Control power supply	single phase, 230V, 50/60Hz,		single phase, 230V, 50/60Hz,	
Capacity of control power supply w/o options	1 kVA		1 kVA	
Capacity of control power supply with options	"depending on options to be used"		"depending on options to be used"	
Fan power supply	3-phase 400 Vac, 50Hz		3-phase 400 Vac, 50Hz	
Capacity of fan power supply (kVA) 5)	5		5	
Maintenance				
Maintenance access	Front		Front	
Cable entry 6)	Bottom in /Bottom out		Bottom in /Bottom out	

ATV6000	C132A3333NA●	
Nominal data	Normal Duty	Heavy Duty
Type rating [kVA]	1320	
Max. Motor power [kW] / [HP] 1)	1050/1408	840/1126
Nominal Continuous output current [A] 1)	220	176
Max. output current with 120 %overload 1 min / 10 min [A]	264	/
Max. output current with 150 % overload1 min / 10 min [A]	/	264
Power cells		
Number of cells per phase	3	
Power cell rated current [A]	220	
Power cell current with 120 %overload 1 min / 10 min [A]	264	
Max. output current for 3 sec [A]	330	
Characteristics with standard efficiency		
Efficiency at 100 % load (incl. Transformer) [%]	96.0%	
Total losses at 100 % load [kW]	45.7	36.6
Air flow [m ³ /h]	12679	
Noise level [dB (A)] @ 50 Hz	80	
Weight [kg / lb]	4811/10584	
Dimension [mm / inch] W*D*H 2)	3560*1400*2754/140.3*55.2*108.6	
Connection		
Incoming cable type	symmetrical three-phase	
Typical cable size (mm ² / AWG) 3)	95/000	
Motor cable type	symmetrical three-phase(Use of shielded cable is advisable)	
Typical cable size (mm ² / AWG) 3)	70/00	
Motor cable Max. length 4)	1000 m	
Grounding connection PE (mm ² / AWG)	50/0	
Control power supply	single phase, 230V, 50/60Hz,	
Capacity of control power supply w/o options	1 kVA	
Capacity of control power supply with options	"depending on options to be used"	
Fan power supply	3-phase 400 Vac, 50Hz	
Capacity of fan power supply (kVA) 5)	5	
Maintenance		
Maintenance access	Front	
Cable entry 6)	Bottom in /Bottom out	
<p>1) Values valid for synchronous motor and asynchronous motor. The specifications for the maximum motor shaft power is based on a motor efficiency of 95%.</p> <p>2) Including the height of top cooling fans.</p> <p>3) For CE products: Typical cable size values based on use of copper cables in cable tray laying. Incoming cable size is based on drive current rating. It has to be checked to be in accordance to mains short circuit capability and local and national electrical code requirement as well all other applicable regulations.</p> <p>4) Variation in max. cable length may be possible depending on type cable and installation. For longer cable length between motor and drive contact Schneider Electric.</p> <p>5) Contact Schneider Electric if N+1 redundancy cooling fan requested.</p> <p>6) For other combination contact Schneider Electric.</p>		

ATV6000C150A3333...ATV6000C167A3333

ATV6000	C150A3333NA●		C167A3333NA●	
Nominal data	Normal Duty	Heavy Duty	Normal Duty	Heavy Duty
Type rating [kVA]	1500		1670	
Max. Motor power [kW] / [HP] 1)	1200/1609	1070/1434	1330/1783	1070/1434
Nominal Continuous output current [A] 1)	251	224	280	224
Max. output current with 120 %overload 1 min / 10 min [A]	301	/	336	/
Max. output current with 150 % overload 1 min / 10 min [A]	/	336	/	336
Power cells				
Number of cells per phase	3		3	
Power cell rated current [A]	280		280	
Power cell current with 120 %overload 1 min / 10 min [A]	336		336	
Max. output current for 3 sec [A]	420		420	
Characteristics with standard efficiency				
Efficiency at 100 % load (incl. Transformer) [%]	96.0%		96.0%	
Total losses at 100 % load [kW]	52.2	46.6	57.9	46.6
Air flow [m³/h]	16620		16620	
Noise level [dB (A)] @ 50 Hz	83		83	
Weight [kg / lb]	5098/11216		5308/11678	
Dimension [mm / inch] W*D*H 2)	3560*1500*2754/ 140.3*59.1*108.6		3560*1500*2754/ 140.3*59.1*108.6	
Connection				
Incoming cable type	symmetrical three-phase		symmetrical three-phase	
Typical cable size (mm² / AWG) 3)	95/000		95/000	
Motor cable type	symmetrical three-phase(Use of shielded cable is advisable)		symmetrical three-phase(Use of shielded cable is advisable)	
Typical cable size (mm² / AWG) 3)	70/00		95/000	
Motor cable Max. length 4)	1000 m		1000 m	
Grounding connection PE (mm² / AWG)	50/0		50/0	
Control power supply	single phase, 230V, 50/60Hz,		single phase, 230V, 50/60Hz,	
Capacity of control power supply w/o options	1 kVA		1 kVA	
Capacity of control power supply with options	"depending on options to be used"		"depending on options to be used"	
Fan power supply	3-phase 400 Vac, 50Hz		3-phase 400 Vac, 50Hz	
Capacity of fan power supply (kVA) 5)	10		10	
Maintenance				
Maintenance access	Front		Front	
Cable entry 6)	Bottom in /Bottom out		Bottom in /Bottom out	
1) Values valid for synchronous motor and asynchronous motor. The specifications for the maximum motor shaft power is based on a motor efficiency of 95%. 2) Including the height of top cooling fans. 3) For CE products: Typical cable size values based on use of copper cables in cable tray laying. Incoming cable size is based on drive current rating. It has to be checked to be in accordance to mains short circuit capability and local and national electrical code requirement as well all other applicable regulations. 4) Variation in max. cable length may be possible depending on type cable and installation. For longer cable length between motor and drive contact Schneider Electric. 5) Contact Schneider Electric if N+1 redundancy cooling fan requested. 6) For other combination contact Schneider Electric.				

ATV6000C190A3333...ATV6000C244A3333

ATV6000	C190A3333NA●		C213A3333NA●	
Nominal data	Normal Duty	Heavy Duty	Normal Duty	Heavy Duty
Type rating [kVA]	1900		2130	
Max. Motor power [kW] / [HP] 1)	1520/2038	1220/1636	1700/2279	1560/2091
Nominal Continuous output current [A] 1)	320	256	356	328
Max. output current with 120 %overload 1 min / 10 min [A]	384	/	427	/
Max. output current with 150 % overload 1 min / 10 min [A]	/	384	/	492
Power cells				
Number of cells per phase	3		3	
Power cell rated current [A]	320		410	
Power cell current with 120 %overload 1 min / 10 min [A]	384		492	
Max. output current for 3 sec [A]	480		615	
Characteristics with standard efficiency				
Efficiency at 100 % load (incl. Transformer) [%]	96.0%		96.0%	
Total losses at 100 % load [kW]	66.1	53.1	73.9	67.9
Air flow [m ³ /h]	15564		15564	
Noise level [dB (A)] @ 50 Hz	80		80	
Weight [kg / lb]	6565/14443		6850/15070	
Dimension [mm / inch] W*D*H 2)	4460*1500*2690/ 175.8*59.1*106		4460*1500*2690/ 175.8*59.1*106	
Connection				
Incoming cable type	symmetrical three-phase		symmetrical three-phase	
Typical cable size (mm ² / AWG) 3)	120/0000		150/300MCM	
Motor cable type	symmetrical three-phase(Use of shielded cable is advisable)		symmetrical three-phase(Use of shielded cable is advisable)	
Typical cable size (mm ² / AWG) 3)	120/0000		150/300MCM	
Motor cable Max. length 4)	1000 m		1000 m	
Grounding connection PE (mm ² / AWG)	50/0		70/00	
Control power supply	single phase, 230V, 50/60Hz,		single phase, 230V, 50/60Hz,	
Capacity of control power supply w/o options	1 kVA		1 kVA	
Capacity of control power supply with options	"depending on options to be used"		"depending on options to be used"	
Fan power supply	3-phase 400 Vac, 50Hz		3-phase 400 Vac, 50Hz	
Capacity of fan power supply (kVA) 5)	7		7	
Maintenance				
Maintenance access	Front		Front	
Cable entry 6)	Bottom in /Bottom out		Bottom in /Bottom out	

ATV6000	C244A3333NA●	
Nominal data	Normal Duty	Heavy Duty
Type rating [kVA]	2440	
Max. Motor power [kW] / [HP] 1)	1950/2614	1560/2091
Nominal Continuous output current [A] 1)	410	328
Max. output current with 120 %overload 1 min / 10 min [A]	492	/
Max. output current with 150 % overload 1 min / 10 min [A]	/	492
Power cells		
Number of cells per phase	3	
Power cell rated current [A]	410	
Power cell current with 120 %overload 1 min / 10 min [A]	492	
Max. output current for 3 sec [A]	615	
Characteristics with standard efficiency		
Efficiency at 100 % load (incl. Transformer) [%]	96.0%	
Total losses at 100 % load [kW]	84.8	67.9
Air flow [m ³ /h]	15564	
Noise level [dB (A)] @ 50 Hz	80	
Weight [kg / lb]	7233/15913	
Dimension [mm / inch] W*D*H 2)	4460*1500*2690/175.8*59.1*106	
Connection		
Incoming cable type	symmetrical three-phase	
Typical cable size (mm ² / AWG) 3)	185/350MCM	
Motor cable type	symmetrical three-phase(Use of shielded cable is advisable)	
Typical cable size (mm ² / AWG) 3)	185/350MCM	
Motor cable Max. length 4)	1000 m	
Grounding connection PE (mm ² / AWG)	70/00	
Control power supply	single phase, 230V, 50/60Hz,	
Capacity of control power supply w/o options	1 kVA	
Capacity of control power supply with options	"depending on options to be used"	
Fan power supply	3-phase 400 Vac, 50Hz	
Capacity of fan power supply (kVA) 5)	7	
Maintenance		
Maintenance access	Front	
Cable entry 6)	Bottom in /Bottom out	
1) Values valid for synchronous motor and asynchronous motor. The specifications for the maximum motor shaft power is based on a motor efficiency of 95%. 2) Including the height of top cooling fans. 3) For CE products: Typical cable size values based on use of copper cables in cable tray laying. Incoming cable size is based on drive current rating. It has to be checked to be in accordance to mains short circuit capability and local and national electrical code requirement as well all other applicable regulations. 4) Variation in max. cable length may be possible depending on type cable and installation. For longer cable length between motor and drive contact Schneider Electric. 5) Contact Schneider Electric if N+1 redundancy cooling fan requested. 6) For other combination contact Schneider Electric.		

ATV6000C293A3333

ATV6000	C293A3333NA●	
Nominal data	Normal Duty	Heavy Duty
Type rating [kVA]	2930	
Max. Motor power [kW] / [HP] 1)	2340/3137	1870/2507
Nominal Continuous output current [A] 1)	490	392
Max. output current with 120 %overload 1 min / 10 min [A]	588	/
Max. output current with 150 % overload 1 min / 10 min [A]	/	588
Power cells		
Number of cells per phase	3	
Power cell rated current [A]	490	
Power cell current with 120 %overload 1 min / 10 min [A]	588	
Max. output current for 3 sec [A]	735	
Characteristics with standard efficiency		
Efficiency at 100 % load (incl. Transformer) [%]	96.0%	
Total losses at 100 % load [kW]	101.8	81.3
Air flow [m ³ /h]	18120	
Noise level [dB (A)] @ 50 Hz	80	
Weight [kg / lb]	7860/17292	
Dimension [mm / inch] W*D*H 2)	4460*1600*2754/175.8*63.1*108.6	
Connection		
Incoming cable type	symmetrical three-phase	
Typical cable size (mm ² / AWG) 3)	95*2/2*000	
Motor cable type	symmetrical three-phase(Use of shielded cable is advisable)	
Typical cable size (mm ² / AWG) 3)	240/500MCM	
Motor cable Max. length 4)	1000 m	
Grounding connection PE (mm ² / AWG)	95/000	
Control power supply	single phase, 230V, 50/60Hz,	
Capacity of control power supply w/o options	1 kVA	
Capacity of control power supply with options	"depending on options to be used"	
Fan power supply	3-phase 400 Vac, 50Hz	
Capacity of fan power supply (kVA) 5)	9	
Maintenance		
Maintenance access	Front	
Cable entry 6)	Bottom in /Bottom out	
<p>1) Values valid for synchronous motor and asynchronous motor. The specifications for the maximum motor shaft power is based on a motor efficiency of 95%.</p> <p>2) Including the height of top cooling fans.</p> <p>3) For CE products: Typical cable size values based on use of copper cables in cable tray laying. Incoming cable size is based on drive current rating. It has to be checked to be in accordance to mains short circuit capability and local and national electrical code requirement as well all other applicable regulations.</p> <p>4) Variation in max. cable length may be possible depending on type cable and installation. For longer cable length between motor and drive contact Schneider Electric.</p> <p>5) Contact Schneider Electric if N+1 redundancy cooling fan requested.</p> <p>6) For other combination contact Schneider Electric.</p>		

ATV6000C328A3333...ATV6000C463A3333

ATV6000	C328A3333NA●		C350A3333NA●	
Nominal data	Normal Duty	Heavy Duty	Normal Duty	Heavy Duty
Type rating [kVA]	3280		3500	
Max. Motor power [kW] / [HP] 1)	2620/3513	2100/2816	2800/3754	2690/3607
Nominal Continuous output current [A] 1)	550	440	586	563
Max. output current with 120 %overload 1 min / 10 min [A]	660	/	703	/
Max. output current with 150 % overload 1 min / 10 min [A]	/	660	/	845
Power cells				
Number of cells per phase	3		3	
Power cell rated current [A]	550		720	
Power cell current with 120 %overload 1 min / 10 min [A]	660		864	
Max. output current for 3 sec [A]	825		1080	
Characteristics with standard efficiency				
Efficiency at 100 % load (incl. Transformer) [%]	96.0%		96.0%	
Total losses at 100 % load [kW]	113.8	91.3	121.7	117.0
Air flow [m³/h]	30600		30600	
Noise level [dB (A)] @ 50 Hz	85		85	
Weight [kg / lb]	9964/21921		10237/22521	
Dimension [mm / inch] W*D*H 2)	5760*1700*2795/227*67*110.2		5760*1700*2795/227*67*110.2	
Connection				
Incoming cable type	symmetrical three-phase		symmetrical three-phase	
Typical cable size (mm² / AWG) 3)	95*2/2*000		95*2/2*000	
Motor cable type	symmetrical three-phase(Use of shielded cable is advisable)		symmetrical three-phase(Use of shielded cable is advisable)	
Typical cable size (mm² / AWG) 3)	95*2/2*000		95*2/2*000	
Motor cable Max. length 4)	1000 m		1000 m	
Grounding connection PE (mm² / AWG)	95/000		120/0000	
Control power supply	single phase, 230V, 50/60Hz,		single phase, 230V, 50/60Hz,	
Capacity of control power supply w/o options	1 kVA		1 kVA	
Capacity of control power supply with options	"depending on options to be used"		"depending on options to be used"	
Fan power supply	3-phase 400 Vac, 50Hz		3-phase 400 Vac, 50Hz	
Capacity of fan power supply (kVA) 5)	25		25	
Maintenance				
Maintenance access	Front		Front	
Cable entry 6)	Bottom in /Bottom out		Bottom in /Bottom out	

ATV6000	C388A3333NA●		C430A3333NA●	
	Normal Duty	Heavy Duty	Normal Duty	Heavy Duty
Nominal data				
Type rating [kVA]	3880		4300	
Max. Motor power [kW] / [HP] 1)	3100/4157	2750/3687	3440/4613	2750/3687
Nominal Continuous output current [A] 1)	649	576	720	576
Max. output current with 120 % overload 1 min / 10 min [A]	779	/	864	/
Max. output current with 150 % overload 1 min / 10 min [A]	/	864	/	864
Power cells				
Number of cells per phase	3		3	
Power cell rated current [A]	720		720	
Power cell current with 120 % overload 1 min / 10 min [A]	864		864	
Max. output current for 3 sec [A]	1080		1080	
Characteristics with standard efficiency				
Efficiency at 100 % load (incl. Transformer) [%]	96.0%		96.0%	
Total losses at 100 % load [kW]	134.7	119.5	149.5	119.5
Air flow [m ³ /h]	30600		30600	
Noise level [dB (A)] @ 50 Hz	85		85	
Weight [kg / lb]	10707/23555		11227/24699	
Dimension [mm / inch] W*D*H 2)	5760*1700*2795/227*67*110.2		5760*1700*2795/227*67*110.2	
Connection				
Incoming cable type	symmetrical three-phase		symmetrical three-phase	
Typical cable size (mm ² / AWG) 3)	120*2/2*0000		150*2/2*300MCM	
Motor cable type	symmetrical three-phase(Use of shielded cable is advisable)		symmetrical three-phase(Use of shielded cable is advisable)	
Typical cable size (mm ² / AWG) 3)	120*2/2*0000		150*2/2*300MCM	
Motor cable Max. length 4)	1000 m		1000 m	
Grounding connection PE (mm ² / AWG)	120/0000		120/0000	
Control power supply	single phase, 230V, 50/60Hz,		single phase, 230V, 50/60Hz,	
Capacity of control power supply w/o options	1 kVA		1 kVA	
Capacity of control power supply with options	"depending on options to be used"		"depending on options to be used"	
Fan power supply	3-phase 400 Vac, 50Hz		3-phase 400 Vac, 50Hz	
Capacity of fan power supply (kVA) 5)	25		25	
Maintenance				
Maintenance access	Front		Front	
Cable entry 6)	Bottom in /Bottom out		Bottom in /Bottom out	

ATV6000	C463A3333NA●	
Nominal data	Normal Duty	Heavy Duty
Type rating [kVA]	4630	
Max. Motor power [kW] / [HP] 1)	3700/4961	3240/4344
Nominal Continuous output current [A] 1)	774	680
Max. output current with 120 %overload 1 min / 10 min [A]	929	/
Max. output current with 150 % overload 1 min / 10 min [A]	/	1020
Power cells		
Number of cells per phase	3	
Power cell rated current [A]	850	
Power cell current with 120 %overload 1 min / 10 min [A]	1020	
Max. output current for 3 sec [A]	1275	
Characteristics with standard efficiency		
Efficiency at 100 % load (incl. Transformer) [%]	96.0%	
Total losses at 100 % load [kW]	160.8	140.8
Air flow [m ³ /h]	31944	
Noise level [dB (A)] @ 50 Hz	85	
Weight [kg / lb]	11697/25733	
Dimension [mm / inch] W*D*H 2)	5760*1700*2795/227*67*110.2	
Connection		
Incoming cable type	symmetrical three-phase	
Typical cable size (mm ² / AWG) 3)	185*2/2*350MCM	
Motor cable type	symmetrical three-phase(Use of shielded cable is advisable)	
Typical cable size (mm ² / AWG) 3)	240*2/2*500MCM	
Motor cable Max. length 4)	1000 m	
Grounding connection PE (mm ² / AWG)	150/300MCM	
Control power supply	single phase, 230V, 50/60Hz,	
Capacity of control power supply w/o options	1 kVA	
Capacity of control power supply with options	"depending on options to be used"	
Fan power supply	3-phase 400 Vac, 50Hz	
Capacity of fan power supply (kVA) 5)	29	
Maintenance		
Maintenance access	Front	
Cable entry 6)	Bottom in /Bottom out	
1) Values valid for synchronous motor and asynchronous motor. The specifications for the maximum motor shaft power is based on a motor efficiency of 95%. 2) Including the height of top cooling fans. 3) For CE products: Typical cable size values based on use of copper cables in cable tray laying. Incoming cable size is based on drive current rating. It has to be checked to be in accordance to mains short circuit capability and local and national electrical code requirement as well all other applicable regulations. 4) Variation in max. cable length may be possible depending on type cable and installation. For longer cable length between motor and drive contact Schneider Electric. 5) Contact Schneider Electric if N+1 redundancy cooling fan requested. 6) For other combination contact Schneider Electric.		

ATV6000C508A3333

ATV6000	C508A3333NA●	
Nominal data	Normal Duty	Heavy Duty
Type rating [kVA]	5080	
Max. Motor power [kW] / [HP] 1)	4060/5444	3240/4344
Nominal Continuous output current [A] 1)	850	680
Max. output current with 120 %overload 1 min / 10 min [A]	1020	/
Max. output current with 150 % overload 1 min / 10 min [A]	/	1020
Power cells		
Number of cells per phase	3	
Power cell rated current [A]	850	
Power cell current with 120 %overload 1 min / 10 min [A]	1020	
Max. output current for 3 sec [A]	1275	
Characteristics with standard efficiency		
Efficiency at 100 % load (incl. Transformer) [%]	96.5%	
Total losses at 100 % load [kW]	153.7	122.7
Air flow [m ³ /h]	31944	
Noise level [dB (A)] @ 50 Hz	85	
Weight [kg / lb]	12337/27141	
Dimension [mm / inch] W*D*H 2)	5760*1800*2795/227*71*110.2	
Connection		
Incoming cable type	symmetrical three-phase	
Typical cable size (mm ² / AWG) 3)	240*2/2*500MCM	
Motor cable type	symmetrical three-phase(Use of shielded cable is advisable)	
Typical cable size (mm ² / AWG) 3)	240*2/2*500MCM	
Motor cable Max. length 4)	1000 m	
Grounding connection PE (mm ² / AWG)	150/300MCM	
Control power supply	single phase, 230V, 50/60Hz,	
Capacity of control power supply w/o options	1 kVA	
Capacity of control power supply with options	"depending on options to be used"	
Fan power supply	3-phase 400 Vac, 50Hz	
Capacity of fan power supply (kVA) 5)	29	
Maintenance		
Maintenance access	Front	
Cable entry 6)	Bottom in /Bottom out	
<p>1) Values valid for synchronous motor and asynchronous motor. The specifications for the maximum motor shaft power is based on a motor efficiency of 95%.</p> <p>2) Including the height of top cooling fans.</p> <p>3) For CE products: Typical cable size values based on use of copper cables in cable tray laying. Incoming cable size is based on drive current rating. It has to be checked to be in accordance to mains short circuit capability and local and national electrical code requirement as well all other applicable regulations.</p> <p>4) Variation in max. cable length may be possible depending on type cable and installation. For longer cable length between motor and drive contact Schneider Electric.</p> <p>5) Contact Schneider Electric if N+1 redundancy cooling fan requested.</p> <p>6) For other combination contact Schneider Electric.</p>		

ATV6000C550A3333...ATV6000C600A3333

ATV6000	C550A3333NA●		C600A3333NA●	
Nominal data	Normal Duty	Heavy Duty	Normal Duty	Heavy Duty
Type rating [kVA]	5500		6000	
Max. Motor power [kW] / [HP] 1)	4400/5900	3820/5122	4770/6396	3820/5122
Nominal Continuous output current [A] 1)	921	800	1000	800
Max. output current with 120 %overload 1 min / 10 min [A]	1105	/	1200	/
Max. output current with 150 % overload 1 min / 10 min [A]	/	1200	/	1200
Power cells				
Number of cells per phase	3		3	
Power cell rated current [A]	1000		1000	
Power cell current with 120 %overload 1 min / 10 min [A]	1200		1200	
Max. output current for 3 sec [A]	1500		1500	
Characteristics with standard efficiency				
Efficiency at 100 % load (incl. Transformer) [%]	96.5%		96.5%	
Total losses at 100 % load [kW]	166.6	144.7	180.6	144.7
Air flow [m³/h]	31944		31944	
Noise level [dB (A)] @ 50 Hz	85		85	
Weight [kg / lb]	13268/29190		13887/30551	
Dimension [mm / inch] W*D*H 2)	6060*1800*3155/ 238.8*71*124.4		6060*1800*3155/ 238.8*71*124.4	
Connection				
Incoming cable type	symmetrical three-phase		symmetrical three-phase	
Typical cable size (mm² / AWG) 3)	240*2/2*500MCM		150*3/3*300MCM	
Motor cable type	symmetrical three-phase(Use of shielded cable is advisable)		symmetrical three-phase(Use of shielded cable is advisable)	
Typical cable size (mm² / AWG) 3)	240*2/2*500MCM		240*2/2*500MCM	
Motor cable Max. length 4)	1000 m		1000 m	
Grounding connection PE (mm² / AWG)	185/350MCM		185/350MCM	
Control power supply	single phase, 230V, 50/60Hz,		single phase, 230V, 50/60Hz,	
Capacity of control power supply w/o options	1 kVA		1 kVA	
Capacity of control power supply with options	"depending on options to be used"		"depending on options to be used"	
Fan power supply	3-phase 400 Vac, 50Hz		3-phase 400 Vac, 50Hz	
Capacity of fan power supply (kVA) 5)	29		29	
Maintenance				
Maintenance access	Front		Front	
Cable entry 6)	Bottom in /Bottom out		Bottom in /Bottom out	
1) Values valid for synchronous motor and asynchronous motor. The specifications for the maximum motor shaft power is based on a motor efficiency of 95%. 2) Including the height of top cooling fans. 3) For CE products: Typical cable size values based on use of copper cables in cable tray laying. Incoming cable size is based on drive current rating. It has to be checked to be in accordance to mains short circuit capability and local and national electrical code requirement as well all other applicable regulations. 4) Variation in max. cable length may be possible depending on type cable and installation. For longer cable length between motor and drive contact Schneider Electric. 5) Contact Schneider Electric if N+1 redundancy cooling fan requested. 6) For other combination contact Schneider Electric.				

Layout Drawing and Dimensions

Layout Drawing

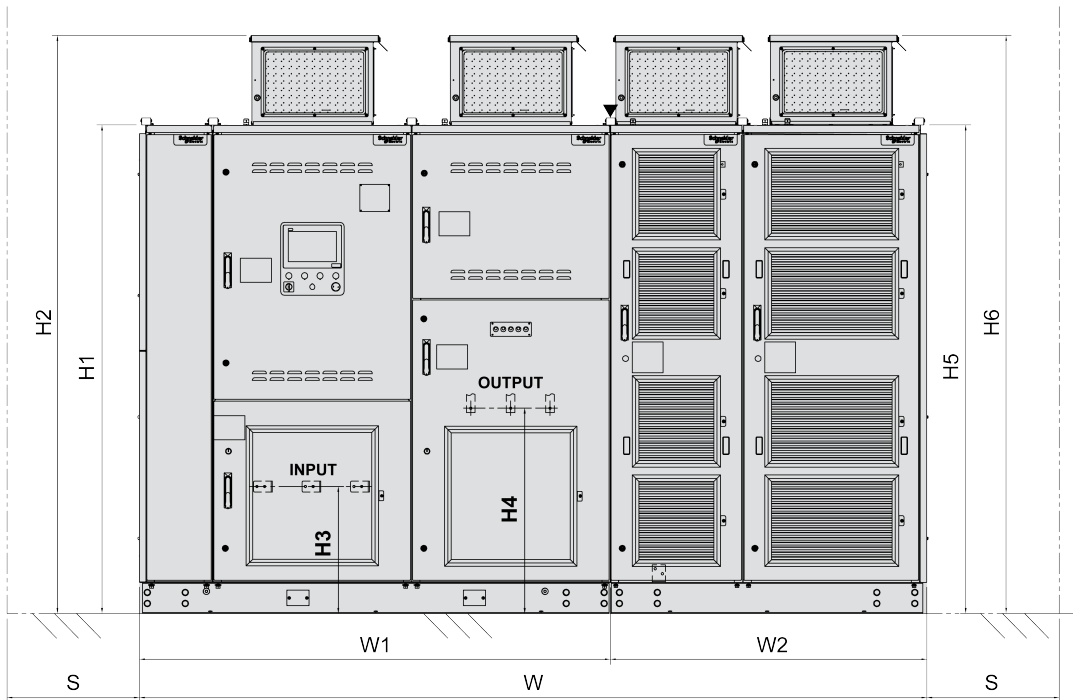

INPUT: Input terminal

OUTPUT: Output terminal

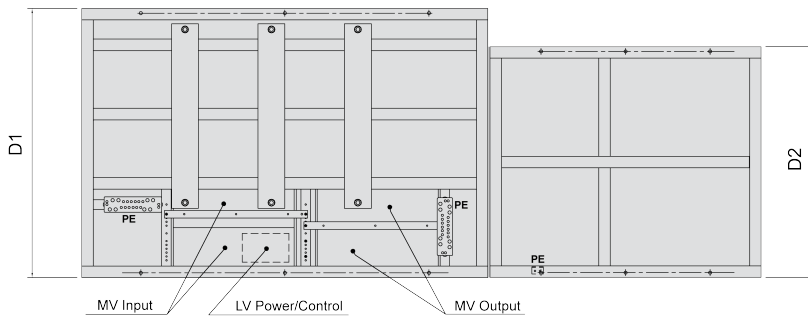

MV Input: MV Input cable area

LV Power/Control: LV Power/Control cable area

MV Output: MV Output cable area

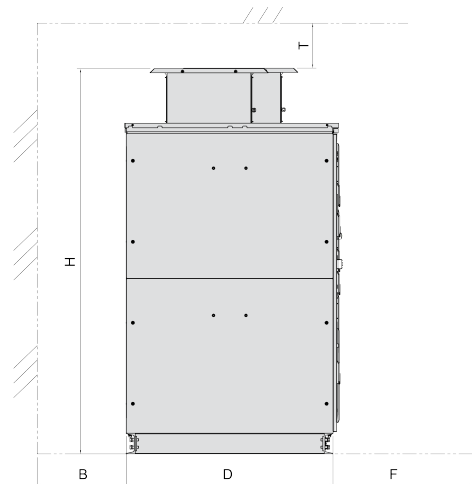

NOTE: Sketch is representing outline dimensions only, real cabinet arrangement is depending on power size.

Main dimensions - Output Voltage 3.3 kV

Product reference	Outer dimensions (mm / in)			Transformer cabinet			Powercell cabinet		
	W	H ^(b)	D	Fan Type	Fan Number	Weight [kg / lb]	Fan Type	Fan number	Weight [kg / lb]
ATV6000D390A3333...	2460	2540	1400	400	2	2217.1	400	1	606.5
	97	100	55			4877.6			1334.3
ATV6000D500A3333...	2460	2540	1400	400	2	2353.3	400	1	606.5
	97	100	55			5177.2			1334.3
ATV6000D590A3333...	2460	2540	1400	400	2	2464.7	400	1	606.5
	97	100	55			5422.3			1334.3
ATV6000D700A3333...	2760	2645	1400	400	2	2600.9	560	1	920.2
	109	104	55			5721.9			2024.4
ATV6000D790A3333...	2760	2645	1400	400	2	2712.3	560	1	920.2
	109	104	55			5967.1			2024.4
ATV6000D890A3333...	2760	2645	1400	400	2	2836.1	560	1	920.2
	109	104	55			6239.5			2024.4
ATV6000C100A3333...	3560	2754	1400	450	2	3122.7	400	2	1292
	140	108	55			6869.9			2842.4
ATV6000C113A3333...	3560	2754	1400	450	2	3283.6	400	2	1292
	140	108	55			7224			2842.4
ATV6000C132A3333...	3560	2754	1400	450	2	3518.9	400	2	1292
	140	108	55			7741.5			2842.4
ATV6000C150A3333...	3560	2754	1500	450	2	3777	500	2	1320.2
	140	108	59			8309.5			2904.4
ATV6000C167A3333...	3560	2754	1500	450	2	3987.5	500	2	1320.2
	140	108	59			8772.5			2904.4
ATV6000C190A3333...	4460	2690	1500	400	3	4402.2	400	3	2162.2
	176	106	59			9684.8			4756.8
ATV6000C213A3333...	4460	2690	1500	400	3	4687	400	3	2162.2
	176	106	59			10311.3			4756.8
ATV6000C244A3333...	4460	2690	1500	400	3	5070.8	400	3	2162.2
	176	106	59			11155.7			4756.8
ATV6000C293A3333...	4460	2754	1600	450	3	5707.7	450	3	2151.7
	176	108	63			12557			4733.7
ATV6000C328A3333...	5760	2795	1700	560	3	6309.2	500	3	3654.4
	227	110	67			13880.3			8039.7
ATV6000C350A3333...	5760	2795	1700	560	3	6581.6	500	3	3654.4
	227	110	67			14479.5			8039.7
ATV6000C388A3333...	5760	2795	1700	560	3	7052.1	500	3	3654.4
	227	110	67			15514.6			8039.7
ATV6000C430A3333...	5760	2795	1700	560	3	7572.1	500	3	3654.4
	227	110	67			16658.5			8039.7
ATV6000C463A3333...	5760	2795	1700	560	3	7980.6	560	3	3716.2
	227	110	67			17557.4			8175.6

Product reference	Outer dimensions (mm / in)			Transformer cabinet			Powercell cabinet		
	W	H ^(b)	D	Fan Type	Fan Number	Weight [kg / lb]	Fan Type	Fan number	Weight [kg / lb]
ATV6000C508A3333...	5760	2795	1800	560	3	8620.2	560	3	3716.2
	227	110	71			18964.4			8175.6
ATV6000C550A3333...	6060	3155	1800	560	3	9469.2	560	3	3798.3
	239	124	71			20832.2			8356.3
ATV6000C600A3333...	6060	3155	1800	560	3	10088.2	560	3	3798.3
	239	124	71			22194.1			8356.3

a) "H" is linked to higher size of transformer cabinet (H2) or transformer cabinet (H6).

Additional Dimensions - Output Voltage 3.3 kV

Product reference	Transformer Cabinet						Power cell Cabinet				Space Maintenance			
	(mm / in)						(mm / in)				(mm / in)			
	H1	H2	H3	H4	W1	D1	H5	H6	W2	D2	T	B (a)	F (b)	S (c)
ATV6000D390A3333...	2210	2540	500	780	1830	1400	2210	2540	630	1200	≥500	0	1500	0
	87	100	20	31	72	55	87	100	25	47	≥20		59	
ATV6000D500A3333...	2210	2540	500	780	1830	1400	2210	2540	630	1200	≥500	0	1500	0
	87	100	20	31	72	55	87	100	25	47	≥20		59	
ATV6000D590A3333...	2210	2540	500	780	1830	1400	2210	2540	630	1200	≥500	0	1500	0
	87	100	20	31	72	55	87	100	25	47	≥20		59	
ATV6000D700A3333...	2210	2540	500	780	1830	1400	2210	2645	930	1200	≥500	0	1500	0
	87	100	20	31	72	55	87	104	37	47	≥20		59	
ATV6000D790A3333...	2210	2540	500	780	1830	1400	2210	2645	930	1200	≥500	0	1500	0
	87	100	20	31	72	55	87	104	37	47	≥20		59	
ATV6000D890A3333...	2210	2540	500	780	1830	1400	2210	2645	930	1200	≥500	0	1500	0
	87	100	20	31	72	55	87	104	37	47	≥20		59	
ATV6000C100A3333...	2360	2754	500	930	2130	1400	2210	2540	1430	1200	≥500	0	1500	0
	93	108	20	37	84	55	87	100	56	47	≥20		59	
ATV6000C113A3333...	2360	2754	500	930	2130	1400	2210	2540	1430	1200	≥500	0	1500	0
	93	108	20	37	84	55	87	100	56	47	≥20		59	
ATV6000C132A3333...	2360	2754	500	930	2130	1400	2210	2540	1430	1200	≥500	0	1500	0
	93	108	20	37	84	55	87	100	56	47	≥20		59	
ATV6000C150A3333...	2360	2754	500	930	2130	1500	2210	2618	1430	1200	≥500	0	1500	0
	93	108	20	37	84	59	87	103	56	47	≥20		59	
ATV6000C167A3333...	2360	2754	500	930	2130	1500	2210	2618	1430	1200	≥500	0	1500	0
	93	108	20	37	84	59	87	103	56	47	≥20		59	
ATV6000C190A3333...	2360	2690	500	930	2430	1500	2360	2690	2030	1200	≥500	0	1500	0
	93	106	20	37	96	59	93	106	80	47	≥20		59	
ATV6000C213A3333...	2360	2690	500	930	2430	1500	2360	2690	2030	1200	≥500	0	1500	0
	93	106	20	37	96	59	93	106	80	47	≥20		59	
ATV6000C244A3333...	2360	2690	500	930	2430	1500	2360	2690	2030	1200	≥500	0	1500	0
	93	106	20	37	96	59	93	106	80	47	≥20		59	
ATV6000C293A3333...	2360	2754	500	930	2430	1600	2360	2754	2030	1200	≥500	0	1500	0
	93	108	20	37	96	63	93	108	80	47	≥20		59	
ATV6000C328A3333...	2360	2795	500	930	2730	1700	2360	2768	3030	1400	≥500	0	1500	0
	93	110	20	37	107	67	93	109	119	55	≥20		59	
ATV6000C350A3333...	2360	2795	500	930	2730	1700	2360	2768	3030	1400	≥500	0	1500	0
	93	110	20	37	107	67	93	109	119	55	≥20		59	
ATV6000C388A3333...	2360	2795	500	930	2730	1700	2360	2768	3030	1400	≥500	0	1500	0
	93	110	20	37	107	67	93	109	119	55	≥20		59	
ATV6000C430A3333...	2360	2795	500	930	2730	1700	2360	2768	3030	1400	≥500	0	1500	0
	93	110	20	37	107	67	93	109	119	55	≥20		59	
ATV6000C463A3333...	2360	2795	500	930	2730	1700	2360	2795	3030	1400	≥500	0	1500	0
	93	110	20	37	107	67	93	110	119	55	≥20		59	

Product reference	Transformer Cabinet (mm / in)						Power cell Cabinet (mm / in)				Space Maintenance (mm / in)			
	H1	H2	H3	H4	W1	D1	H5	H6	W2	D2	T	B (a)	F (b)	S(c)
ATV6000C508A3333...	2360	2795	500	930	2730	1800	2360	2795	3030	1400	≥500	0	1500	0
	93	110	20	37	107	71	93	110	119	55	≥20		59	
ATV6000C550A3333...	2720	3155	560	1290	3030	1800	2420	2855	3030	1600	≥500	0	1500	0
	107	124	22	51	119	71	95	112	119	63	≥20		59	
ATV6000C600A3333...	2720	3155	560	1290	3030	1800	2420	2855	3030	1600	≥500	0	1500	0
	107	124	22	51	119	71	95	112	119	63	≥20		59	

a) Space could be required for installation and lifting lugs.
b) For easy handling with power cell exchange tool 2000mm (78.7 in) are recommended.
c) Space (600mm) could be required for maintenance of the front & rear access drive.

Output Voltage 4.16 kV

ATV6000D350A4242...ATV6000D750A4242

ATV6000	D350A4242NA●		D490A4242NA●	
	Normal Duty	Heavy Duty	Normal Duty	Heavy Duty
Nominal data				
Type rating [kVA]	350		490	
Max. Motor power [kW] / [HP] 1)	280/375	260/348	390/522	310/415
Nominal Continuous output current [A] 1)	46.5	44	65	52
Max. output current with 120 %overload 1 min / 10 min [A]	55.8	/	78	/
Max. output current with 150 % overload 1 min / 10 min [A]	/	66	/	78
Power cells				
Number of cells per phase	4		4	
Power cell rated current [A]	65		65	
Power cell current with 120 %overload 1 min / 10 min [A]	78		78	
Max. output current for 3 sec [A]	97.5		97.5	
Characteristics with standard efficiency				
Efficiency at 100 % load (incl. Transformer) [%]	96.0%		96.0%	
Total losses at 100 % load [kW]	12.2	11.4	17.0	13.5
Air flow [m³/h]	7374		7374	
Noise level [dB (A)] @ 50 Hz	80		80	
Weight [kg / lb]	2903/6387		3077/6769	
Dimension [mm / inch] W*D*H 2)	2660*1400*2540/ 104.9*55.2*100.1		2660*1400*2540/ 104.9*55.2*100.1	
Connection				
Incoming cable type	symmetrical three-phase		symmetrical three-phase	
Typical cable size (mm² / AWG) 3)	95/000		95/000	
Motor cable type	symmetrical three-phase(Use of shielded cable is advisable)		symmetrical three-phase(Use of shielded cable is advisable)	
Typical cable size (mm² / AWG) 3)	25/4		25/4	
Motor cable Max. length 4)	3280 ft (1000 m)		3280 ft (1000 m)	
Grounding connection PE (mm² / AWG)	50/0		50/0	
Control power supply	single phase, 230V, 50/60Hz		single phase, 230V, 50/60Hz	
Capacity of control power supply w/o options	1 kVA		1 kVA	
Capacity of control power supply with options	"depending on options to be used"		"depending on options to be used"	
Fan power supply	3-phase 400 Vac, 50Hz		3-phase 400 Vac, 50Hz	
Capacity of fan power supply (kVA) 5)	4		4	
Maintenance				
Maintenance access	Front		Front	
Cable entry 6)	Bottom in /Bottom out		Bottom in /Bottom out	

ATV6000	D570A4242NA●		D630A4242NA●	
	Normal Duty	Heavy Duty	Normal Duty	Heavy Duty
Nominal data				
Type rating [kVA]	570		630	
Max. Motor power [kW] / [HP] 1)	450/603	420/563	500/670	470/630
Nominal Continuous output current [A] 1)	74.7	71	83	79
Max. output current with 120 %overload 1 min / 10 min [A]	89.6	/	99.6	/
Max. output current with 150 % overload1 min / 10 min [A]	/	107	/	119
Power cells				
Number of cells per phase	4		4	
Power cell rated current [A]	100		100	
Power cell current with 120 %overload 1 min / 10 min [A]	120		120	
Max. output current for 3 sec [A]	150		150	
Characteristics with standard efficiency				
Efficiency at 100 % load (incl. Transformer) [%]	96.0%		96.0%	
Total losses at 100 % load [kW]	19.7	18.4	21.9	20.5
Air flow [m ³ /h]	7374		7374	
Noise level [dB (A)] @ 50 Hz	80		80	
Weight [kg / lb]	3176/6987		3250/7150	
Dimension [mm / inch] W*D*H 2)	2660*1400*2540/ 104.9*55.2*100.1		2660*1400*2540/ 104.9*55.2*100.1	
Connection				
Incoming cable type	symmetrical three-phase		symmetrical three-phase	
Typical cable size (mm ² / AWG) 3)	95/000		95/000	
Motor cable type	symmetrical three-phase(Use of shielded cable is advisable)		symmetrical three-phase(Use of shielded cable is advisable)	
Typical cable size (mm ² / AWG) 3)	25/4		25/4	
Motor cable Max. length 4)	3280 ft (1000 m)		3280 ft (1000 m)	
Grounding connection PE (mm ² / AWG)	50/0		50/0	
Control power supply	single phase, 230V, 50/60Hz		single phase, 230V, 50/60Hz	
Capacity of control power supply w/o options	1 kVA		1 kVA	
Capacity of control power supply with options	"depending on options to be used"		"depending on options to be used"	
Fan power supply	3-phase 400 Vac, 50Hz		3-phase 400 Vac, 50Hz	
Capacity of fan power supply (kVA) 5)	4		4	
Maintenance				
Maintenance access	Front		Front	
Cable entry 6)	Bottom in /Bottom out		Bottom in /Bottom out	

ATV6000	D750A4242NA●	
Nominal data	Normal Duty	Heavy Duty
Type rating [kVA]	750	
Max. Motor power [kW] / [HP] 1)	600/804	480/643
Nominal Continuous output current [A] 1)	100	80
Max. output current with 120 %overload 1 min / 10 min [A]	120	/
Max. output current with 150 % overload 1 min / 10 min [A]	/	120
Power cells		
Number of cells per phase	4	
Power cell rated current [A]	100	
Power cell current with 120 %overload 1 min / 10 min [A]	120	
Max. output current for 3 sec [A]	150	
Characteristics with standard efficiency		
Efficiency at 100 % load (incl. Transformer) [%]	96.0%	
Total losses at 100 % load [kW]	26.2	20.9
Air flow [m³/h]	7374	
Noise level [dB (A)] @ 50 Hz	80	
Weight [kg / lb]	3398/7476	
Dimension [mm / inch] W*D*H 2)	2660*1400*2540/104.9*55.2*100.1	
Connection		
Incoming cable type	symmetrical three-phase	
Typical cable size (mm² / AWG) 3)	95/000	
Motor cable type	symmetrical three-phase(Use of shielded cable is advisable)	
Typical cable size (mm² / AWG) 3)	25/4	
Motor cable Max. length 4)	3280 ft (1000 m)	
Grounding connection PE (mm² / AWG)	50/0	
Control power supply	single phase, 230V, 50/60Hz	
Capacity of control power supply w/o options	1 kVA	
Capacity of control power supply with options	"depending on options to be used"	
Fan power supply	3-phase 400 Vac, 50Hz	
Capacity of fan power supply (kVA) 5)	4	
Maintenance		
Maintenance access	Front	
Cable entry 6)	Bottom in /Bottom out	
1) Values valid for synchronous motor and asynchronous motor. The specifications for the maximum motor shaft power is based on a motor efficiency of 95%. 2) Including the height of top cooling fans. 3) For CE products: Typical cable size values based on use of copper cables in cable tray laying. Incoming cable size is based on drive current rating. It has to be checked to be in accordance to mains short circuit capability and local and national electrical code requirement as well all other applicable regulations. 4) Variation in max. cable length may be possible depending on type cable and installation. For longer cable length between motor and drive contact Schneider Electric. 5) Contact Schneider Electric if N+1 redundancy cooling fan requested. 6) For other combination contact Schneider Electric.		

ATV6000D890A4242

ATV6000	D890A4242NA●	
Nominal data	Normal Duty	Heavy Duty
Type rating [kVA]	890	
Max. Motor power [kW] / [HP] 1)	710/952	680/911
Nominal Continuous output current [A] 1)	118	113
Max. output current with 120 %overload 1 min / 10 min [A]	141	/
Max. output current with 150 % overload 1 min / 10 min [A]	/	170
Power cells		
Number of cells per phase	4	
Power cell rated current [A]	150	
Power cell current with 120 %overload 1 min / 10 min [A]	180	
Max. output current for 3 sec [A]	225	
Characteristics with standard efficiency		
Efficiency at 100 % load (incl. Transformer) [%]	96.0%	
Total losses at 100 % load [kW]	30.9	29.7
Air flow [m ³ /h]	12049	
Noise level [dB (A)] @ 50 Hz	80	
Weight [kg / lb]	4122/9068	
Dimension [mm / inch] W*D*H 2)	3260*1400*2604/128.5*55.2*102.6	
Connection		
Incoming cable type	symmetrical three-phase	
Typical cable size (mm ² / AWG) 3)	95/000	
Motor cable type	symmetrical three-phase(Use of shielded cable is advisable)	
Typical cable size (mm ² / AWG) 3)	35/2	
Motor cable Max. length 4)	3280 ft (1000 m)	
Grounding connection PE (mm ² / AWG)	50/0	
Control power supply	single phase, 230V, 50/60Hz	
Capacity of control power supply w/o options	1 kVA	
Capacity of control power supply with options	"depending on options to be used"	
Fan power supply	3-phase 400 Vac, 50Hz	
Capacity of fan power supply (kVA) 5)	5	
Maintenance		
Maintenance access	Front	
Cable entry 6)	Bottom in /Bottom out	
<p>1) Values valid for synchronous motor and asynchronous motor. The specifications for the maximum motor shaft power is based on a motor efficiency of 95%.</p> <p>2) Including the height of top cooling fans.</p> <p>3) For CE products: Typical cable size values based on use of copper cables in cable tray laying. Incoming cable size is based on drive current rating. It has to be checked to be in accordance to mains short circuit capability and local and national electrical code requirement as well all other applicable regulations.</p> <p>4) Variation in max. cable length may be possible depending on type cable and installation. For longer cable length between motor and drive contact Schneider Electric.</p> <p>5) Contact Schneider Electric if N+1 redundancy cooling fan requested.</p> <p>6) For other combination contact Schneider Electric.</p>		

ATV6000C100A4242...ATV6000C113A4242

ATV6000	C100A4242NA●		C113A4242NA●	
Nominal data	Normal Duty	Heavy Duty	Normal Duty	Heavy Duty
Type rating [kVA]	1000		1130	
Max. Motor power [kW] / [HP] 1)	800/1072	720/965	900/1206	720/965
Nominal Continuous output current [A] 1)	133	120	150	120
Max. output current with 120 %overload 1 min / 10 min [A]	159	/	180	/
Max. output current with 150 % overload 1 min / 10 min [A]	/	180	/	180
Power cells				
Number of cells per phase	4		4	
Power cell rated current [A]	150		150	
Power cell current with 120 %overload 1 min / 10 min [A]	180		180	
Max. output current for 3 sec [A]	225		225	
Characteristics with standard efficiency				
Efficiency at 100 % load (incl. Transformer) [%]	96.0%		96.0%	
Total losses at 100 % load [kW]	34.9	31.4	39.2	31.4
Air flow [m³/h]	14100		14100	
Noise level [dB (A)] @ 50 Hz	80		80	
Weight [kg / lb]	4388/9654		4549/10008	
Dimension [mm / inch] W*D*H 2)	3560*1400*2604/ 140.3*55.2*102.6		3560*1400*2604/ 140.3*55.2*102.6	
Connection				
Incoming cable type	symmetrical three-phase		symmetrical three-phase	
Typical cable size (mm² / AWG) 3)	95/000		95/000	
Motor cable type	symmetrical three-phase(Use of shielded cable is advisable)		symmetrical three-phase(Use of shielded cable is advisable)	
Typical cable size (mm² / AWG) 3)	35/2		35/2	
Motor cable Max. length 4)	3280 ft (1000 m)		3280 ft (1000 m)	
Grounding connection PE (mm² / AWG)	50/0		50/0	
Control power supply	single phase, 230V, 50/60Hz		single phase, 230V, 50/60Hz	
Capacity of control power supply w/o options	1 kVA		1 kVA	
Capacity of control power supply with options	"depending on options to be used"		"depending on options to be used"	
Fan power supply	3-phase 400 Vac, 50Hz		3-phase 400 Vac, 50Hz	
Capacity of fan power supply (kVA) 5)	6		6	
Maintenance				
Maintenance access	Front		Front	
Cable entry 6)	Bottom in /Bottom out		Bottom in /Bottom out	
1) Values valid for synchronous motor and asynchronous motor. The specifications for the maximum motor shaft power is based on a motor efficiency of 95%. 2) Including the height of top cooling fans. 3) For CE products: Typical cable size values based on use of copper cables in cable tray laying. Incoming cable size is based on drive current rating. It has to be checked to be in accordance to mains short circuit capability and local and national electrical code requirement as well all other applicable regulations. 4) Variation in max. cable length may be possible depending on type cable and installation. For longer cable length between motor and drive contact Schneider Electric. 5) Contact Schneider Electric if N+1 redundancy cooling fan requested. 6) For other combination contact Schneider Electric.				

ATV6000C125A4242...ATV6000C165A4242

ATV6000	C125A4242NA●		C150A4242NA●	
Nominal data	Normal Duty	Heavy Duty	Normal Duty	Heavy Duty
Type rating [kVA]	1250		1500	
Max. Motor power [kW] / [HP] 1)	1000/1341	950/1273	1200/1609	960/1287
Nominal Continuous output current [A] 1)	166	159	199	160
Max. output current with 120 %overload 1 min / 10 min [A]	199	/	239	/
Max. output current with 150 % overload 1 min / 10 min [A]	/	239	/	240
Power cells				
Number of cells per phase	4		4	
Power cell rated current [A]	200		200	
Power cell current with 120 %overload 1 min / 10 min [A]	240		240	
Max. output current for 3 sec [A]	300		300	
Characteristics with standard efficiency				
Efficiency at 100 % load (incl. Transformer) [%]	96.0%		96.0%	
Total losses at 100 % load [kW]	43.6	41.4	52.2	41.8
Air flow [m ³ /h]	13538		13538	
Noise level [dB (A)] @ 50 Hz	80		80	
Weight [kg / lb]	4959/10910		5268/11590	
Dimension [mm / inch] W*D*H 2)	3760*1400*2754/ 148.2*55.2*108.6		3760*1400*2754/ 148.2*55.2*108.6	
Connection				
Incoming cable type	symmetrical three-phase		symmetrical three-phase	
Typical cable size (mm ² / AWG) 3)	95/000		95/000	
Motor cable type	symmetrical three-phase(Use of shielded cable is advisable)		symmetrical three-phase(Use of shielded cable is advisable)	
Typical cable size (mm ² / AWG) 3)	35/2		50/0	
Motor cable Max. length 4)	3280 ft (1000 m)		3280 ft (1000 m)	
Grounding connection PE (mm ² / AWG)	50/0		50/0	
Control power supply	single phase, 230V, 50/60Hz		single phase, 230V, 50/60Hz	
Capacity of control power supply w/o options	1 kVA		1 kVA	
Capacity of control power supply with options	"depending on options to be used"		"depending on options to be used"	
Fan power supply	3-phase 400 Vac, 50Hz		3-phase 400 Vac, 50Hz	
Capacity of fan power supply (kVA) 5)	5		5	
Maintenance				
Maintenance access	Front		Front	
Cable entry 6)	Bottom in /Bottom out		Bottom in /Bottom out	

ATV6000	C165A4242NA●	
Nominal data	Normal Duty	Heavy Duty
Type rating [kVA]	1650	
Max. Motor power [kW] / [HP] 1)	1320/1770	1060/1421
Nominal Continuous output current [A] 1)	220	176
Max. output current with 120 %overload 1 min / 10 min [A]	264	/
Max. output current with 150 % overload 1 min / 10 min [A]	/	264
Power cells		
Number of cells per phase	4	
Power cell rated current [A]	220	
Power cell current with 120 %overload 1 min / 10 min [A]	264	
Max. output current for 3 sec [A]	330	
Characteristics with standard efficiency		
Efficiency at 100 % load (incl. Transformer) [%]	96.0%	
Total losses at 100 % load [kW]	57.4	46.1
Air flow [m ³ /h]	13538	
Noise level [dB (A)] @ 50 Hz	80	
Weight [kg / lb]	5454/11999	
Dimension [mm / inch] W*D*H 2)	3760*1400*2754/148.2*55.2*108.6	
Connection		
Incoming cable type	symmetrical three-phase	
Typical cable size (mm ² / AWG) 3)	95/000	
Motor cable type	symmetrical three-phase(Use of shielded cable is advisable)	
Typical cable size (mm ² / AWG) 3)	70/00	
Motor cable Max. length 4)	3280 ft (1000 m)	
Grounding connection PE (mm ² / AWG)	50/0	
Control power supply	single phase, 230V, 50/60Hz	
Capacity of control power supply w/o options	1 kVA	
Capacity of control power supply with options	"depending on options to be used"	
Fan power supply	3-phase 400 Vac, 50Hz	
Capacity of fan power supply (kVA) 5)	5	
Maintenance		
Maintenance access	Front	
Cable entry 6)	Bottom in /Bottom out	
1) Values valid for synchronous motor and asynchronous motor. The specifications for the maximum motor shaft power is based on a motor efficiency of 95%. 2) Including the height of top cooling fans. 3) For CE products: Typical cable size values based on use of copper cables in cable tray laying. Incoming cable size is based on drive current rating. It has to be checked to be in accordance to mains short circuit capability and local and national electrical code requirement as well all other applicable regulations. 4) Variation in max. cable length may be possible depending on type cable and installation. For longer cable length between motor and drive contact Schneider Electric. 5) Contact Schneider Electric if N+1 redundancy cooling fan requested. 6) For other combination contact Schneider Electric.		

ATV6000C188A4242...ATV6000C210A4242

ATV6000	C188A4242NA●		C210A4242NA●	
	Normal Duty	Heavy Duty	Normal Duty	Heavy Duty
Nominal data				
Type rating [kVA]	1880		2100	
Max. Motor power [kW] / [HP] 1)	1500/2011	1340/1796	1680/2252	1340/1796
Nominal Continuous output current [A] 1)	249	224	280	224
Max. output current with 120 %overload 1 min / 10 min [A]	299	/	336	/
Max. output current with 150 % overload 1 min / 10 min [A]	/	336	/	336
Power cells				
Number of cells per phase	4		4	
Power cell rated current [A]	280		280	
Power cell current with 120 %overload 1 min / 10 min [A]	336		336	
Max. output current for 3 sec [A]	420		420	
Characteristics with standard efficiency				
Efficiency at 100 % load (incl. Transformer) [%]	96.0%		96.0%	
Total losses at 100 % load [kW]	65.3	58.3	73.1	58.3
Air flow [m ³ /h]	21542		21542	
Noise level [dB (A)] @ 50 Hz	83		83	
Weight [kg / lb]	5966/13125		6239/13726	
Dimension [mm / inch] W*D*H 2)	4060*1500*2754/ 160*59.1*108.6		4060*1500*2754/ 160*59.1*108.6	
Connection				
Incoming cable type	symmetrical three-phase		symmetrical three-phase	
Typical cable size (mm ² / AWG) 3)	95/000		95/000	
Motor cable type	symmetrical three-phase(Use of shielded cable is advisable)		symmetrical three-phase(Use of shielded cable is advisable)	
Typical cable size (mm ² / AWG) 3)	70/00		95/000	
Motor cable Max. length 4)	3280 ft (1000 m)		3280 ft (1000 m)	
Grounding connection PE (mm ² / AWG)	50/0		50/0	
Control power supply	single phase, 230V, 50/60Hz		single phase, 230V, 50/60Hz	
Capacity of control power supply w/o options	1 kVA		1 kVA	
Capacity of control power supply with options	"depending on options to be used"		"depending on options to be used"	
Fan power supply	3-phase 400 Vac, 50Hz		3-phase 400 Vac, 50Hz	
Capacity of fan power supply (kVA) 5)	14		14	
Maintenance				
Maintenance access	Front		Front	
Cable entry 6)	Bottom in /Bottom out		Bottom in /Bottom out	
<p>1) Values valid for synchronous motor and asynchronous motor. The specifications for the maximum motor shaft power is based on a motor efficiency of 95%.</p> <p>2) Including the height of top cooling fans.</p> <p>3) For CE products: Typical cable size values based on use of copper cables in cable tray laying. Incoming cable size is based on drive current rating. It has to be checked to be in accordance to mains short circuit capability and local and national electrical code requirement as well all other applicable regulations.</p> <p>4) Variation in max. cable length may be possible depending on type cable and installation. For longer cable length between motor and drive contact Schneider Electric.</p> <p>5) Contact Schneider Electric if N+1 redundancy cooling fan requested.</p> <p>6) For other combination contact Schneider Electric.</p>				

ATV6000C240A4242...ATV6000C275A4242

ATV6000	C240A4242NA●		C275A4242NA●	
Nominal data	Normal Duty	Heavy Duty	Normal Duty	Heavy Duty
Type rating [kVA]	2400		2750	
Max. Motor power [kW] / [HP] 1)	1920/2574	1540/2065	2200/2950	1970/2641
Nominal Continuous output current [A] 1)	320	256	365	328
Max. output current with 120 %overload 1 min / 10 min [A]	384	/	438	/
Max. output current with 150 % overload 1 min / 10 min [A]	/	384	/	492
Power cells				
Number of cells per phase	4		4	
Power cell rated current [A]	320		410	
Power cell current with 120 %overload 1 min / 10 min [A]	384		492	
Max. output current for 3 sec [A]	480		615	
Characteristics with standard efficiency				
Efficiency at 100 % load (incl. Transformer) [%]	96.0%		96.0%	
Total losses at 100 % load [kW]	83.5	66.9	95.6	85.6
Air flow [m³/h]	19267		19267	
Noise level [dB (A)] @ 50 Hz	80		80	
Weight [kg / lb]	7843/17255		8276/18207	
Dimension [mm / inch] W*D*H 2)	5060*1500*2754/ 199.4*59.1*108.6		5060*1500*2754/ 199.4*59.1*108.6	
Connection				
Incoming cable type	symmetrical three-phase		symmetrical three-phase	
Typical cable size (mm² / AWG) 3)	120/0000		150/300MCM	
Motor cable type	symmetrical three-phase(Use of shielded cable is advisable)		symmetrical three-phase(Use of shielded cable is advisable)	
Typical cable size (mm² / AWG) 3)	120/0000		150/300MCM	
Motor cable Max. length 4)	3280 ft (1000 m)		3280 ft (1000 m)	
Grounding connection PE (mm² / AWG)	50/0		70/00	
Control power supply	single phase, 230V, 50/60Hz		single phase, 230V, 50/60Hz	
Capacity of control power supply w/o options	1 kVA		1 kVA	
Capacity of control power supply with options	"depending on options to be used"		"depending on options to be used"	
Fan power supply	3-phase 400 Vac, 50Hz		3-phase 400 Vac, 50Hz	
Capacity of fan power supply (kVA) 5)	9		9	
Maintenance				
Maintenance access	Front		Front	
Cable entry 6)	Bottom in /Bottom out		Bottom in /Bottom out	
1) Values valid for synchronous motor and asynchronous motor. The specifications for the maximum motor shaft power is based on a motor efficiency of 95%. 2) Including the height of top cooling fans. 3) For CE products: Typical cable size values based on use of copper cables in cable tray laying. Incoming cable size is based on drive current rating. It has to be checked to be in accordance to mains short circuit capability and local and national electrical code requirement as well all other applicable regulations. 4) Variation in max. cable length may be possible depending on type cable and installation. For longer cable length between motor and drive contact Schneider Electric. 5) Contact Schneider Electric if N+1 redundancy cooling fan requested. 6) For other combination contact Schneider Electric.				

ATV6000C308A4242

ATV6000	C308A4242NA●	
Nominal data	Normal Duty	Heavy Duty
Type rating [kVA]	3080	
Max. Motor power [kW] / [HP] 1)	2460/3298	1970/2641
Nominal Continuous output current [A] 1)	410	328
Max. output current with 120 %overload 1 min / 10 min [A]	492	/
Max. output current with 150 % overload 1 min / 10 min [A]	/	492
Power cells		
Number of cells per phase	4	
Power cell rated current [A]	410	
Power cell current with 120 %overload 1 min / 10 min [A]	492	
Max. output current for 3 sec [A]	615	
Characteristics with standard efficiency		
Efficiency at 100 % load (incl. Transformer) [%]	96.0%	
Total losses at 100 % load [kW]	107.0	85.6
Air flow [m ³ /h]	19267	
Noise level [dB (A)] @ 50 Hz	80	
Weight [kg / lb]	8725/19195	
Dimension [mm / inch] W*D*H 2)	5060*1600*2754/199.4*63.1*108.6	
Connection		
Incoming cable type	symmetrical three-phase	
Typical cable size (mm ² / AWG) 3)	185/350MCM	
Motor cable type	symmetrical three-phase(Use of shielded cable is advisable)	
Typical cable size (mm ² / AWG) 3)	185/350MCM	
Motor cable Max. length 4)	3280 ft (1000 m)	
Grounding connection PE (mm ² / AWG)	70/00	
Control power supply	single phase, 230V, 50/60Hz	
Capacity of control power supply w/o options	1 kVA	
Capacity of control power supply with options	"depending on options to be used"	
Fan power supply	3-phase 400 Vac, 50Hz	
Capacity of fan power supply (kVA) 5)	9	
Maintenance		
Maintenance access	Front	
Cable entry 6)	Bottom in /Bottom out	
<p>1) Values valid for synchronous motor and asynchronous motor. The specifications for the maximum motor shaft power is based on a motor efficiency of 95%.</p> <p>2) Including the height of top cooling fans.</p> <p>3) For CE products: Typical cable size values based on use of copper cables in cable tray laying. Incoming cable size is based on drive current rating. It has to be checked to be in accordance to mains short circuit capability and local and national electrical code requirement as well all other applicable regulations.</p> <p>4) Variation in max. cable length may be possible depending on type cable and installation. For longer cable length between motor and drive contact Schneider Electric.</p> <p>5) Contact Schneider Electric if N+1 redundancy cooling fan requested.</p> <p>6) For other combination contact Schneider Electric.</p>		

ATV6000C338A4242...ATV6000C369A4242

ATV6000	C338A4242NA●		C369A4242NA●	
Nominal data	Normal Duty	Heavy Duty	Normal Duty	Heavy Duty
Type rating [kVA]	3380		3690	
Max. Motor power [kW] / [HP] 1)	2700/3620	2360/3164	2950/3956	2360/3164
Nominal Continuous output current [A] 1)	448	392	490	392
Max. output current with 120 %overload 1 min / 10 min [A]	538	/	588	/
Max. output current with 150 % overload 1 min / 10 min [A]	/	588	/	588
Power cells				
Number of cells per phase	4		4	
Power cell rated current [A]	490		490	
Power cell current with 120 %overload 1 min / 10 min [A]	588		588	
Max. output current for 3 sec [A]	735		735	
Characteristics with standard efficiency				
Efficiency at 100 % load (incl. Transformer) [%]	96.0%		96.0%	
Total losses at 100 % load [kW]	117.3	102.6	128.2	102.6
Air flow [m³/h]	22080		22080	
Noise level [dB (A)] @ 50 Hz	83		83	
Weight [kg / lb]	9327/20519		9711/21364	
Dimension [mm / inch] W*D*H 2)	5360*1700*2754/ 211.2*67*108.6		5360*1700*2754/ 211.2*67*108.6	
Connection				
Incoming cable type	symmetrical three-phase		symmetrical three-phase	
Typical cable size (mm² / AWG) 3)	240/500MCM		95*2/2*000	
Motor cable type	symmetrical three-phase(Use of shielded cable is advisable)		symmetrical three-phase(Use of shielded cable is advisable)	
Typical cable size (mm² / AWG) 3)	240/500MCM		240/500MCM	
Motor cable Max. length 4)	3280 ft (1000 m)		3280 ft (1000 m)	
Grounding connection PE (mm² / AWG)	95/000		95/000	
Control power supply	single phase, 230V, 50/60Hz		single phase, 230V, 50/60Hz	
Capacity of control power supply w/o options	1 kVA		1 kVA	
Capacity of control power supply with options	"depending on options to be used"		"depending on options to be used"	
Fan power supply	3-phase 400 Vac, 50Hz		3-phase 400 Vac, 50Hz	
Capacity of fan power supply (kVA) 5)	10		10	
Maintenance				
Maintenance access	Front		Front	
Cable entry 6)	Bottom in /Bottom out		Bottom in /Bottom out	
1) Values valid for synchronous motor and asynchronous motor. The specifications for the maximum motor shaft power is based on a motor efficiency of 95%. 2) Including the height of top cooling fans. 3) For CE products: Typical cable size values based on use of copper cables in cable tray laying. Incoming cable size is based on drive current rating. It has to be checked to be in accordance to mains short circuit capability and local and national electrical code requirement as well all other applicable regulations. 4) Variation in max. cable length may be possible depending on type cable and installation. For longer cable length between motor and drive contact Schneider Electric. 5) Contact Schneider Electric if N+1 redundancy cooling fan requested. 6) For other combination contact Schneider Electric.				

ATV6000C414A4242...ATV6000C542A4242

ATV6000	C414A4242NA●		C463A4242NA●	
Nominal data	Normal Duty	Heavy Duty	Normal Duty	Heavy Duty
Type rating [kVA]	4140		4630	
Max. Motor power [kW] / [HP] 1)	3310/4438	2650/3553	3700/4961	3460/4639
Nominal Continuous output current [A] 1)	550	440	614	576
Max. output current with 120 %overload 1 min / 10 min [A]	660	/	737	/
Max. output current with 150 % overload 1 min / 10 min [A]	/	660	/	864
Power cells				
Number of cells per phase	4		4	
Power cell rated current [A]	550		720	
Power cell current with 120 %overload 1 min / 10 min [A]	660		864	
Max. output current for 3 sec [A]	825		1080	
Characteristics with standard efficiency				
Efficiency at 100 % load (incl. Transformer) [%]	96.0%		96.0%	
Total losses at 100 % load [kW]	143.8	115.2	160.8	150.4
Air flow [m ³ /h]	36360		36360	
Noise level [dB (A)] @ 50 Hz	85		85	
Weight [kg / lb]	12154/26739		12761/28074	
Dimension [mm / inch] W*D*H 2)	6560*1800*2795/ 258.5*71*110.2		6560*1800*2795/ 258.5*71*110.2	
Connection				
Incoming cable type	symmetrical three-phase		symmetrical three-phase	
Typical cable size (mm ² / AWG) 3)	95*2/2*000		120*2/2*0000	
Motor cable type	symmetrical three-phase(Use of shielded cable is advisable)		symmetrical three-phase(Use of shielded cable is advisable)	
Typical cable size (mm ² / AWG) 3)	95*2/2*000		120*2/2*0000	
Motor cable Max. length 4)	1000 m		1000 m	
Grounding connection PE (mm ² / AWG)	95/000		120/0000	
Control power supply	single phase, 230V, 50/60Hz,		single phase, 230V, 50/60Hz,	
Capacity of control power supply w/o options	1 kVA		1 kVA	
Capacity of control power supply with options	"depending on options to be used"		"depending on options to be used"	
Fan power supply	3-phase 400 Vac, 50Hz		3-phase 400 Vac, 50Hz	
Capacity of fan power supply (kVA) 5)	29		29	
Maintenance				
Maintenance access	Front		Front	
Cable entry 6)	Bottom in /Bottom out		Bottom in /Bottom out	

ATV6000	C500A4242NA●		C542A4242NA●	
	Normal Duty	Heavy Duty	Normal Duty	Heavy Duty
Nominal data				
Type rating [kVA]	5000		5420	
Max. Motor power [kW] / [HP] 1)	4000/5364	3460/4639	4330/5806	3460/4639
Nominal Continuous output current [A] 1)	664	576	720	576
Max. output current with 120 %overload 1 min / 10 min [A]	797	/	864	/
Max. output current with 150 % overload 1 min / 10 min [A]	/	864	/	864
Power cells				
Number of cells per phase	4		4	
Power cell rated current [A]	720		720	
Power cell current with 120 %overload 1 min / 10 min [A]	864		864	
Max. output current for 3 sec [A]	1080		1080	
Characteristics with standard efficiency				
Efficiency at 100 % load (incl. Transformer) [%]	96.5%		96.5%	
Total losses at 100 % load [kW]	151.5	131.0	164.0	131.0
Air flow [m³/h]	36360		36360	
Noise level [dB (A)] @ 50 Hz	85		85	
Weight [kg / lb]	13219/29082		13739/30226	
Dimension [mm / inch] W*D*H 2)	6560*1800*2795/ 258.5*71*110.2		6560*1800*2795/ 258.5*71*110.2	
Connection				
Incoming cable type	symmetrical three-phase		symmetrical three-phase	
Typical cable size (mm² / AWG) 3)	120*2/2*0000		150*2/2*300MCM	
Motor cable type	symmetrical three-phase(Use of shielded cable is advisable)		symmetrical three-phase(Use of shielded cable is advisable)	
Typical cable size (mm² / AWG) 3)	120*2/2*0000		150*2/2*300MCM	
Motor cable Max. length 4)	1000 m		1000 m	
Grounding connection PE (mm² / AWG)	120/0000		120/0000	
Control power supply	single phase, 230V, 50/60Hz,		single phase, 230V, 50/60Hz,	
Capacity of control power supply w/o options	1 kVA		1 kVA	
Capacity of control power supply with options	"depending on options to be used"		"depending on options to be used"	
Fan power supply	3-phase 400 Vac, 50Hz		3-phase 400 Vac, 50Hz	
Capacity of fan power supply (kVA) 5)	29		29	
Maintenance				
Maintenance access	Front		Front	
Cable entry 6)	Bottom in /Bottom out		Bottom in /Bottom out	
1) Values valid for synchronous motor and asynchronous motor. The specifications for the maximum motor shaft power is based on a motor efficiency of 95%. 2) Including the height of top cooling fans. 3) For CE products: Typical cable size values based on use of copper cables in cable tray laying. Incoming cable size is based on drive current rating. It has to be checked to be in accordance to mains short circuit capability and local and national electrical code requirement as well all other applicable regulations. 4) Variation in max. cable length may be possible depending on type cable and installation. For longer cable length between motor and drive contact Schneider Electric. 5) Contact Schneider Electric if N+1 redundancy cooling fan requested. 6) For other combination contact Schneider Electric.				

ATV6000C600A4242...ATV6000C753A4242

ATV6000	C600A4242NA●		C640A4242NA●	
Nominal data	Normal Duty	Heavy Duty	Normal Duty	Heavy Duty
Type rating [kVA]	6000		6400	
Max. Motor power [kW] / [HP] 1)	4800/6436	4090/5484	5120/6866	4090/5484
Nominal Continuous output current [A] 1)	797	680	850	680
Max. output current with 120 %overload 1 min / 10 min [A]	956	/	1020	/
Max. output current with 150 % overload1 min / 10 min [A]	/	1020	/	1020
Power cells				
Number of cells per phase	4		4	
Power cell rated current [A]	850		850	
Power cell current with 120 %overload 1 min / 10 min [A]	1020		1020	
Max. output current for 3 sec [A]	1275		1275	
Characteristics with standard efficiency				
Efficiency at 100 % load (incl. Transformer) [%]	96.5%		96.5%	
Total losses at 100 % load [kW]	181.7	154.9	193.8	154.9
Air flow [m ³ /h]	37992		37992	
Noise level [dB (A)] @ 50 Hz	85		85	
Weight [kg / lb]	14878/32732		15373/33821	
Dimension [mm / inch] W*D*H 2)	6860*1800*3155/ 270.3*71*124.4		6860*1800*3155/ 270.3*71*124.4	
Connection				
Incoming cable type	symmetrical three-phase		symmetrical three-phase	
Typical cable size (mm ² / AWG) 3)	185*2/2*350MCM		240*2/2*500MCM	
Motor cable type	symmetrical three-phase(Use of shielded cable is advisable)		symmetrical three-phase(Use of shielded cable is advisable)	
Typical cable size (mm ² / AWG) 3)	240*2/2*500MCM		240*2/2*500MCM	
Motor cable Max. length 4)	1000 m		1000 m	
Grounding connection PE (mm ² / AWG)	150/300MCM		150/300MCM	
Control power supply	single phase, 230V, 50/60Hz,		single phase, 230V, 50/60Hz,	
Capacity of control power supply w/o options	1 kVA		1 kVA	
Capacity of control power supply with options	"depending on options to be used"		"depending on options to be used"	
Fan power supply	3-phase 400 Vac, 50Hz		3-phase 400 Vac, 50Hz	
Capacity of fan power supply (kVA) 5)	34		34	
Maintenance				
Maintenance access	Front		Front	
Cable entry 6)	Bottom in /Bottom out		Bottom in /Bottom out	

ATV6000	C700A4242NA●		C753A4242NA●	
Nominal data	Normal Duty	Heavy Duty	Normal Duty	Heavy Duty
Type rating [kVA]	7000		7530	
Max. Motor power [kW] / [HP] 1)	5600/7509	4810/6450	6020/8072	4810/6450
Nominal Continuous output current [A] 1)	930	800	1000	800
Max. output current with 120 %overload 1 min / 10 min [A]	1116	/	1200	/
Max. output current with 150 % overload 1 min / 10 min [A]	/	1200	/	1200
Power cells				
Number of cells per phase	4		4	
Power cell rated current [A]	1000		1000	
Power cell current with 120 %overload 1 min / 10 min [A]	1200		1200	
Max. output current for 3 sec [A]	1500		1500	
Characteristics with standard efficiency				
Efficiency at 100 % load (incl. Transformer) [%]	96.5%		96.5%	
Total losses at 100 % load [kW]	212.0	182.2	227.9	182.2
Air flow [m³/h]	37992		37992	
Noise level [dB (A)] @ 50 Hz	85		85	
Weight [kg / lb]	16205/35651		16861/37094	
Dimension [mm / inch] W*D*H 2)	6860*1800*3155/ 270.3*71*124.4		6860*1800*3155/ 270.3*71*124.4	
Connection				
Incoming cable type	symmetrical three-phase		symmetrical three-phase	
Typical cable size (mm² / AWG) 3)	240*2/2*500MCM		120*3/3*0000	
Motor cable type	symmetrical three-phase(Use of shielded cable is advisable)		symmetrical three-phase(Use of shielded cable is advisable)	
Typical cable size (mm² / AWG) 3)	240*2/2*500MCM		240*2/2*500MCM	
Motor cable Max. length 4)	1000 m		1000 m	
Grounding connection PE (mm² / AWG)	185/350MCM		185/350MCM	
Control power supply	single phase, 230V, 50/60Hz,		single phase, 230V, 50/60Hz,	
Capacity of control power supply w/o options	1 kVA		1 kVA	
Capacity of control power supply with options	"depending on options to be used"		"depending on options to be used"	
Fan power supply	3-phase 400 Vac, 50Hz		3-phase 400 Vac, 50Hz	
Capacity of fan power supply (kVA) 5)	34		34	
Maintenance				
Maintenance access	Front		Front	
Cable entry 6)	Bottom in /Bottom out		Bottom in /Bottom out	
1) Values valid for synchronous motor and asynchronous motor. The specifications for the maximum motor shaft power is based on a motor efficiency of 95%. 2) Including the height of top cooling fans. 3) For CE products: Typical cable size values based on use of copper cables in cable tray laying. Incoming cable size is based on drive current rating. It has to be checked to be in accordance to mains short circuit capability and local and national electrical code requirement as well all other applicable regulations. 4) Variation in max. cable length may be possible depending on type cable and installation. For longer cable length between motor and drive contact Schneider Electric. 5) Contact Schneider Electric if N+1 redundancy cooling fan requested. 6) For other combination contact Schneider Electric.				

Layout Drawing and Dimensions

Layout Drawing

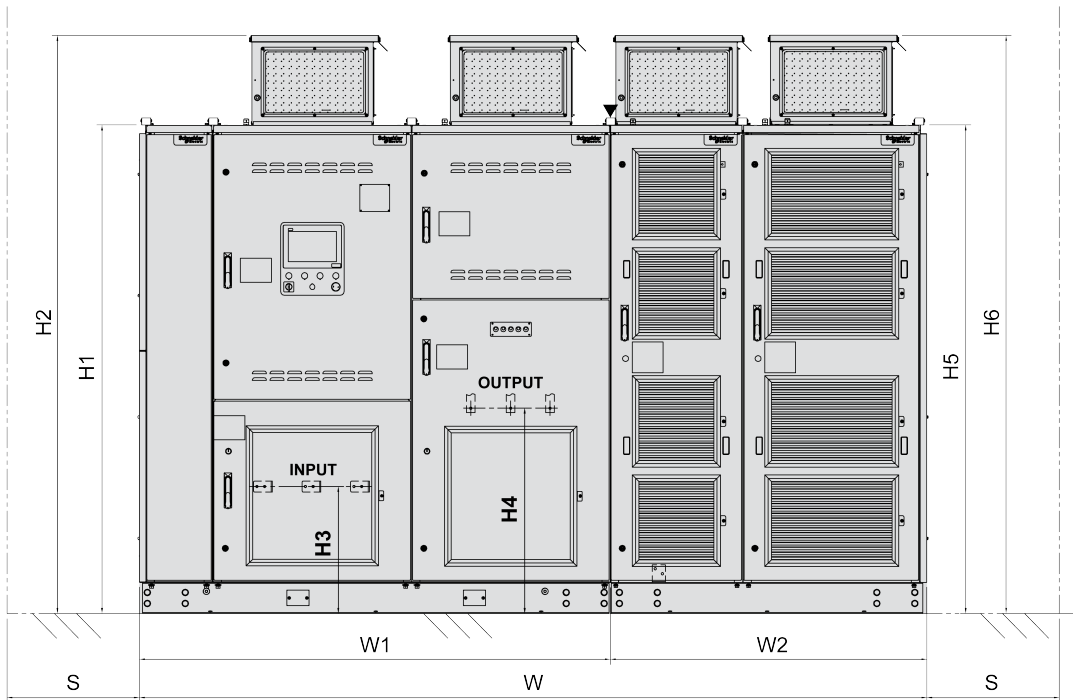

INPUT: Input terminal

OUTPUT: Output terminal

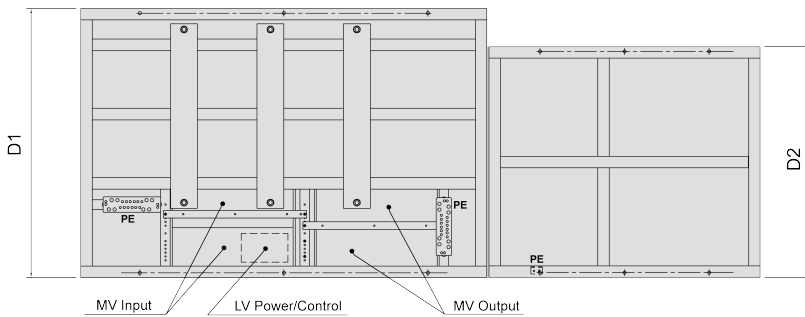

MV Input: MV Input cable area

LV Power/Control: LV Power/Control cable area

MV Output: MV Output cable area

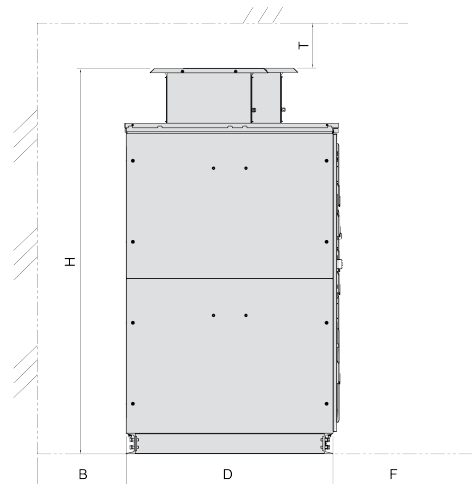

NOTE: Sketch is representing outline dimensions only, real cabinet arrangement is depending on power size.

Main dimensions - Output Voltage 4.2 kV

Product reference	Outer dimensions (mm / in)			Transformer cabinet			Powercell cabinet		
	W	H ^(b)	D	Fan Type	Fan Number	Weight [kg / lb]	Fan Type	Fan number	Weight [kg / lb]
ATV6000D350A4242...	2660	2540	1400	400	2	2167.6	400	1	735.2
	105	100	55			4768.7			1617.4
ATV6000D490A4242...	2660	2540	1400	400	2	2340.9	400	1	735.2
	105	100	55			5150			1617.4
ATV6000D570A4242...	2660	2540	1400	400	2	2439.9	400	1	735.2
	105	100	55			5367.8			1617.4
ATV6000D630A4242...	2660	2540	1400	400	2	2514.2	400	1	735.2
	105	100	55			5531.2			1617.4
ATV6000D750A4242...	2660	2540	1400	400	2	2662.8	400	1	735.2
	105	100	55			5858.2			1617.4
ATV6000D890A4242...	3260	2604	1400	400	2	2836.1	450	2	1285
	128	103	55			6239.4			2827
ATV6000C100A4242...	3560	2604	1400	450	2	3102.8	450	2	1285
	140	103	55			6826.2			2827
ATV6000C113A4242...	3560	2604	1400	450	2	3263.7	450	2	1285
	140	103	55			7180.1			2827
ATV6000C125A4242...	3760	2754	1400	450	2	3432.2	400	2	1526.1
	148	108	55			7550.8			3357.4
ATV6000C150A4242...	3760	2754	1400	450	2	3741.7	400	2	1526.1
	148	108	55			8231.7			3357.4
ATV6000C165A4242...	3760	2754	1400	450	2	3927.4	400	2	1526.1
	148	108	55			8640.3			3357.4
ATV6000C188A4242...	4060	2754	1500	450	3	4370.3	560	2	1595.5
	160	108	59			9614.7			3510.1
ATV6000C210A4242...	4060	2754	1500	450	3	4642.7	560	2	1595.5
	160	108	59			10213.9			3510.1
ATV6000C240A4242...	5060	2754	1500	450	3	5010.7	400	4	2831.3
	199	108	59			11023.5			6228.9
ATV6000C275A4242...	5060	2754	1500	450	3	5444.1	400	4	2831.3
	199	108	59			11977			6228.9
ATV6000C308A4242...	5060	2754	1600	450	3	5893.5	400	4	2831.3
	199	108	63			12965.7			6228.9
ATV6000C338A4242...	5360	2754	1700	450	3	6329.5	450	4	2997.5
	211	108	67			13924.9			6594.5
ATV6000C369A4242...	5360	2754	1700	450	3	6713.3	450	4	2997.5
	211	108	67			14769.3			6594.5
ATV6000C414A4242...	6560	2795	1800	560	3	7456.4	500	4	4697.1
	258	110	71			16404.1			10333.6
ATV6000C463A4242...	6560	2795	1800	560	3	8063.1	500	4	4697.1
	258	110	71			17738.8			10333.6

Product reference	Outer dimensions (mm / in)			Transformer cabinet			Powercell cabinet		
	W	H ^(b)	D	Fan Type	Fan Number	Weight [kg / lb]	Fan Type	Fan number	Weight [kg / lb]
ATV6000C500A4242...	6560	2795	1800	560	3	8521.1	500	4	4697.1
	258	110	71			18746.4			10333.6
ATV6000C542A4242...	6560	2795	1800	560	3	9041.1	500	4	4697.1
	258	110	71			19890.4			10333.6
ATV6000C600A4242...	6860	3155	1800	560	3	10097.8	560	4	4779.5
	270	124	71			22215.2			10514.9
ATV6000C640A4242...	6860	3155	1800	560	3	10593	560	4	4779.5
	270	124	71			23304.6			10514.9
ATV6000C700A4242...	6860	3155	1800	560	3	11326.3	560	4	4878
	270	124	71			24917.9			10731.6
ATV6000C753A4242...	6860	3155	1800	560	3	11982.5	560	4	4878
	270	124	71			26361.5			10731.6

a) "H" is linked to higher size of transformer cabinet (H2) or transformer cabinet (H6).

Additional Dimensions - Output Voltage 4.2 kV

Product reference	Transformer Cabinet						Power cell Cabinet				Space Maintenance			
	(mm / in)						(mm / in)				(mm / in)			
	H1	H2	H3	H4	W1	D1	H5	H6	W2	D2	T	B (a)	F (b)	S (c)
ATV6000D350A4242***	2210 87	2540 100	500 20	780 31	1830 72	1400 55	2210 87	2540 100	830 33	1200 47	≥500 ≥20	0	1500 59	0
ATV6000D490A4242***	2210 87	2540 100	500 20	780 31	1830 72	1400 55	2210 87	2540 100	830 33	1200 47	≥500 ≥20	0	1500 59	0
ATV6000D570A4242***	2210 87	2540 100	500 20	780 31	1830 72	1400 55	2210 87	2540 100	830 33	1200 47	≥500 ≥20	0	1500 59	0
ATV6000D630A4242***	2210 87	2540 100	500 20	780 31	1830 72	1400 55	2210 87	2540 100	830 33	1200 47	≥500 ≥20	0	1500 59	0
ATV6000D750A4242***	2210 87	2540 100	500 20	780 31	1830 72	1400 55	2210 87	2540 100	830 33	1200 47	≥500 ≥20	0	1500 59	0
ATV6000D890A4242***	2210 87	2540 100	500 20	780 31	1830 72	1400 55	2210 87	2604 103	1430 56	1200 47	≥500 ≥20	0	1500 59	0
ATV6000C100A4242***	2210 87	2604 103	500 20	780 31	2130 84	1400 55	2210 87	2604 103	1430 56	1200 47	≥500 ≥20	0	1500 59	0
ATV6000C113A4242***	2210 87	2604 103	500 20	780 31	2130 84	1400 55	2210 87	2604 103	1430 56	1200 47	≥500 ≥20	0	1500 59	0
ATV6000C125A4242***	2360 93	2754 108	500 20	930 37	2130 84	1400 55	2210 87	2540 100	1630 64	1200 47	≥500 ≥20	0	1500 59	0
ATV6000C150A4242***	2360 93	2754 108	500 20	930 37	2130 84	1400 55	2210 87	2540 100	1630 64	1200 47	≥500 ≥20	0	1500 59	0
ATV6000C165A4242***	2360 93	2754 108	500 20	930 37	2130 84	1400 55	2210 87	2540 100	1630 64	1200 47	≥500 ≥20	0	1500 59	0
ATV6000C188A4242***	2360 93	2754 108	500 20	930 37	2430 96	1500 59	2210 87	2645 104	1630 64	1200 47	≥500 ≥20	0	1500 59	0
ATV6000C210A4242***	2360 93	2754 108	500 20	930 37	2430 96	1500 59	2210 87	2645 104	1630 64	1200 47	≥500 ≥20	0	1500 59	0
ATV6000C240A4242***	2360 93	2754 108	500 20	930 37	2430 96	1500 59	2360 93	2690 106	2630 104	1200 47	≥500 ≥20	0	1500 59	0
ATV6000C275A4242***	2360 93	2754 108	500 20	930 37	2430 96	1500 59	2360 93	2690 106	2630 104	1200 47	≥500 ≥20	0	1500 59	0
ATV6000C308A4242***	2360 93	2754 108	500 20	930 37	2430 96	1600 63	2360 93	2690 106	2630 104	1200 47	≥500 ≥20	0	1500 59	0
ATV6000C338A4242***	2360 93	2754 108	500 20	930 37	2730 107	1700 67	2360 93	2754 108	2630 104	1200 47	≥500 ≥20	0	1500 59	0
ATV6000C369A4242***	2360 93	2754 108	500 20	930 37	2730 107	1700 67	2360 93	2754 108	2630 104	1200 47	≥500 ≥20	0	1500 59	0
ATV6000C414A4242***	2360 93	2795 110	500 20	930 37	2730 107	1800 71	2360 93	2768 109	3830 151	1400 55	≥500 ≥20	0	1500 59	0
ATV6000C463A4242***	2360 93	2795 110	500 20	930 37	2730 107	1800 71	2360 93	2768 109	3830 151	1400 55	≥500 ≥20	0	1500 59	0

Product reference	Transformer Cabinet (mm / in)						Power cell Cabinet (mm / in)				Space Maintenance (mm / in)			
	H1	H2	H3	H4	W1	D1	H5	H6	W2	D2	T	B (a)	F (b)	S(c)
ATV6000C500A4242...	2360	2795	500	930	2730	1800	2360	2768	3830	1400	≥500	0	1500	0
	93	110	20	37	107	71	93	109	151	55	≥20	0	59	0
ATV6000C542A4242...	2360	2795	500	930	2730	1800	2360	2768	3830	1400	≥500	0	1500	0
	93	110	20	37	107	71	93	109	151	55	≥20	0	59	0
ATV6000C600A4242...	2720	3155	560	1290	3030	1800	2420	2855	3830	1400	≥500	0	1500	0
	107	124	22	51	119	71	95	112	151	55	≥20	0	59	0
ATV6000C640A4242...	2720	3155	560	1290	3030	1800	2420	2855	3830	1400	≥500	0	1500	0
	107	124	22	51	119	71	95	112	151	55	≥20	0	59	0
ATV6000C700A4242...	2720	3155	560	1290	3030	1800	2420	2855	3830	1600	≥500	0	1500	0
	107	124	22	51	119	71	95	112	151	63	≥20	0	59	0
ATV6000C753A4242...	2720	3155	560	1290	3030	1800	2420	2855	3830	1600	≥500	0	1500	0
	107	124	22	51	119	71	95	112	151	63	≥20	0	59	0

a) Space could be required for installation and lifting lugs.
b) For easy handling with power cell exchange tool 2000mm (78.7 in) are recommended.
c) Space (600mm) could be required for maintenance of the front & rear access drive.

Output Voltage 5.5 kV

ATV6000D450A5555...ATV6000D890A5555

ATV6000	D450A5555NA●		D570A5555NA●	
	Normal Duty	Heavy Duty	Normal Duty	Heavy Duty
Nominal data				
Type rating [kVA]	450		570	
Max. Motor power [kW] / [HP] 1)	355/476	330/442	450/603	410/549
Nominal Continuous output current [A] 1)	44.6	42	56.5	52
Max. output current with 120 %overload 1 min / 10 min [A]	53.5	/	67.8	/
Max. output current with 150 % overload 1 min / 10 min [A]	/	63	/	78
Power cells				
Number of cells per phase	5		5	
Power cell rated current [A]	65		65	
Power cell current with 120 %overload 1 min / 10 min [A]	78		78	
Max. output current for 3 sec [A]	97.5		97.5	
Characteristics with standard efficiency				
Efficiency at 100 % load (incl. Transformer) [%]	96.0%		96.0%	
Total losses at 100 % load [kW]	15.5	14.4	19.7	17.9
Air flow [m³/h]	9889		9889	
Noise level [dB (A)] @ 50 Hz	80		80	
Weight [kg / lb]	3137/6901		3285/7227	
Dimension [mm / inch] W*D*H 2)	2760*1400*2618/ 108.8*55.2*103.2		2760*1400*2618/ 108.8*55.2*103.2	
Connection				
Incoming cable type	symmetrical three-phase		symmetrical three-phase	
Typical cable size (mm² / AWG) 3)	95/000		95/000	
Motor cable type	symmetrical three-phase(Use of shielded cable is advisable)		symmetrical three-phase(Use of shielded cable is advisable)	
Typical cable size (mm² / AWG) 3)	25/4		25/4	
Motor cable Max. length 4)	1000 m		1000 m	
Grounding connection PE (mm² / AWG)	50/0		50/0	
Control power supply	single phase, 230V, 50/60Hz,		single phase, 230V, 50/60Hz,	
Capacity of control power supply w/o options	1 kVA		1 kVA	
Capacity of control power supply with options	"depending on options to be used"		"depending on options to be used"	
Fan power supply	3-phase 400 Vac, 50Hz		3-phase 400 Vac, 50Hz	
Capacity of fan power supply (kVA) 5)	6		6	
Maintenance				
Maintenance access	Front		Front	
Cable entry 6)	Bottom in /Bottom out		Bottom in /Bottom out	

ATV6000	D640A5555NA●		D790A5555NA●	
Nominal data	Normal Duty	Heavy Duty	Normal Duty	Heavy Duty
Type rating [kVA]	640		790	
Max. Motor power [kW] / [HP] 1)	510/683	410/549	630/844	600/804
Nominal Continuous output current [A] 1)	65	52	79.1	76
Max. output current with 120 %overload 1 min / 10 min [A]	78	/	94.9	/
Max. output current with 150 % overload1 min / 10 min [A]	/	78	/	114
Power cells				
Number of cells per phase	5		5	
Power cell rated current [A]	65		100	
Power cell current with 120 %overload 1 min / 10 min [A]	78		120	
Max. output current for 3 sec [A]	97.5		150	
Characteristics with standard efficiency				
Efficiency at 100 % load (incl. Transformer) [%]	96.0%		96.0%	
Total losses at 100 % load [kW]	22.2	17.9	27.4	26.2
Air flow [m ³ /h]	9889		9889	
Noise level [dB (A)] @ 50 Hz	80		80	
Weight [kg / lb]	3372/7418		3558/7828	
Dimension [mm / inch] W*D*H 2)	2760*1400*2618/ 108.8*55.2*103.2		2760*1400*2618/ 108.8*55.2*103.2	
Connection				
Incoming cable type	symmetrical three-phase		symmetrical three-phase	
Typical cable size (mm ² / AWG) 3)	95/000		95/000	
Motor cable type	symmetrical three-phase(Use of shielded cable is advisable)		symmetrical three-phase(Use of shielded cable is advisable)	
Typical cable size (mm ² / AWG) 3)	25/4		25/4	
Motor cable Max. length 4)	1000 m		1000 m	
Grounding connection PE (mm ² / AWG)	50/0		50/0	
Control power supply	single phase, 230V, 50/60Hz,		single phase, 230V, 50/60Hz,	
Capacity of control power supply w/o options	1 kVA		1 kVA	
Capacity of control power supply with options	"depending on options to be used"		"depending on options to be used"	
Fan power supply	3-phase 400 Vac, 50Hz		3-phase 400 Vac, 50Hz	
Capacity of fan power supply (kVA) 5)	6		6	
Maintenance				
Maintenance access	Front		Front	
Cable entry 6)	Bottom in /Bottom out		Bottom in /Bottom out	

ATV6000	D890A5555NA●	
Nominal data	Normal Duty	Heavy Duty
Type rating [kVA]	890	
Max. Motor power [kW] / [HP] 1)	710/952	630/844
Nominal Continuous output current [A] 1)	89.2	80
Max. output current with 120 %overload 1 min / 10 min [A]	107	/
Max. output current with 150 % overload 1 min / 10 min [A]	/	120
Power cells		
Number of cells per phase	5	
Power cell rated current [A]	100	
Power cell current with 120 %overload 1 min / 10 min [A]	120	
Max. output current for 3 sec [A]	150	
Characteristics with standard efficiency		
Efficiency at 100 % load (incl. Transformer) [%]	96.0%	
Total losses at 100 % load [kW]	30.9	27.4
Air flow [m³/h]	9889	
Noise level [dB (A)] @ 50 Hz	80	
Weight [kg / lb]	3681/8098	
Dimension [mm / inch] W*D*H 2)	2760*1400*2618/108.8*55.2*103.2	
Connection		
Incoming cable type	symmetrical three-phase	
Typical cable size (mm² / AWG) 3)	95/000	
Motor cable type	symmetrical three-phase(Use of shielded cable is advisable)	
Typical cable size (mm² / AWG) 3)	25/4	
Motor cable Max. length 4)	1000 m	
Grounding connection PE (mm² / AWG)	50/0	
Control power supply	single phase, 230V, 50/60Hz,	
Capacity of control power supply w/o options	1 kVA	
Capacity of control power supply with options	"depending on options to be used"	
Fan power supply	3-phase 400 Vac, 50Hz	
Capacity of fan power supply (kVA) 5)	6	
Maintenance		
Maintenance access	Front	
Cable entry 6)	Bottom in /Bottom out	
1) Values valid for synchronous motor and asynchronous motor. The specifications for the maximum motor shaft power is based on a motor efficiency of 95%. 2) Including the height of top cooling fans. 3) For CE products: Typical cable size values based on use of copper cables in cable tray laying. Incoming cable size is based on drive current rating. It has to be checked to be in accordance to mains short circuit capability and local and national electrical code requirement as well all other applicable regulations. 4) Variation in max. cable length may be possible depending on type cable and installation. For longer cable length between motor and drive contact Schneider Electric. 5) Contact Schneider Electric if N+1 redundancy cooling fan requested. 6) For other combination contact Schneider Electric.		

ATV6000D990A5555

ATV6000	D990A5555NA●	
Nominal data	Normal Duty	Heavy Duty
Type rating [kVA]	990	
Max. Motor power [kW] / [HP] 1)	790/1059	630/844
Nominal Continuous output current [A] 1)	100	80
Max. output current with 120 %overload 1 min / 10 min [A]	120	/
Max. output current with 150 % overload 1 min / 10 min [A]	/	120
Power cells		
Number of cells per phase	5	
Power cell rated current [A]	100	
Power cell current with 120 %overload 1 min / 10 min [A]	120	
Max. output current for 3 sec [A]	150	
Characteristics with standard efficiency		
Efficiency at 100 % load (incl. Transformer) [%]	96.0%	
Total losses at 100 % load [kW]	34.4	27.4
Air flow [m ³ /h]	11940	
Noise level [dB (A)] @ 50 Hz	80	
Weight [kg / lb]	3936/8659	
Dimension [mm / inch] W*D*H 2)	3060*1400*2618/120.6*55.2*103.2	
Connection		
Incoming cable type	symmetrical three-phase	
Typical cable size (mm ² / AWG) 3)	95/000	
Motor cable type	symmetrical three-phase(Use of shielded cable is advisable)	
Typical cable size (mm ² / AWG) 3)	25/4	
Motor cable Max. length 4)	1000 m	
Grounding connection PE (mm ² / AWG)	50/0	
Control power supply	single phase, 230V, 50/60Hz,	
Capacity of control power supply w/o options	1 kVA	
Capacity of control power supply with options	"depending on options to be used"	
Fan power supply	3-phase 400 Vac, 50Hz	
Capacity of fan power supply (kVA) 5)	7	
Maintenance		
Maintenance access	Front	
Cable entry 6)	Bottom in /Bottom out	
<p>1) Values valid for synchronous motor and asynchronous motor. The specifications for the maximum motor shaft power is based on a motor efficiency of 95%.</p> <p>2) Including the height of top cooling fans.</p> <p>3) For CE products: Typical cable size values based on use of copper cables in cable tray laying. Incoming cable size is based on drive current rating. It has to be checked to be in accordance to mains short circuit capability and local and national electrical code requirement as well all other applicable regulations.</p> <p>4) Variation in max. cable length may be possible depending on type cable and installation. For longer cable length between motor and drive contact Schneider Electric.</p> <p>5) Contact Schneider Electric if N+1 redundancy cooling fan requested.</p> <p>6) For other combination contact Schneider Electric.</p>		

ATV6000C113A5555...ATV6000C132A5555

ATV6000	C113A5555NA●		C132A5555NA●	
Nominal data	Normal Duty	Heavy Duty	Normal Duty	Heavy Duty
Type rating [kVA]	1130		1320	
Max. Motor power [kW] / [HP] 1)	900/1206	860/1153	1050/1408	950/1273
Nominal Continuous output current [A] 1)	113	108	132	120
Max. output current with 120 %overload 1 min / 10 min [A]	136	/	158	/
Max. output current with 150 % overload 1 min / 10 min [A]	/	162	/	180
Power cells				
Number of cells per phase	5		5	
Power cell rated current [A]	150		150	
Power cell current with 120 %overload 1 min / 10 min [A]	180		180	
Max. output current for 3 sec [A]	225		225	
Characteristics with standard efficiency				
Efficiency at 100 % load (incl. Transformer) [%]	96.0%		96.0%	
Total losses at 100 % load [kW]	39.2	37.4	45.7	41.4
Air flow [m³/h]	17100		17100	
Noise level [dB (A)] @ 50 Hz	83		83	
Weight [kg / lb]	4735/10417		4970/10934	
Dimension [mm / inch] W*D*H 2)	3660*1400*2618/ 144.3*55.2*103.2		3660*1400*2618/ 144.3*55.2*103.2	
Connection				
Incoming cable type	symmetrical three-phase		symmetrical three-phase	
Typical cable size (mm² / AWG) 3)	95/000		95/000	
Motor cable type	symmetrical three-phase(Use of shielded cable is advisable)		symmetrical three-phase(Use of shielded cable is advisable)	
Typical cable size (mm² / AWG) 3)	35/2		35/2	
Motor cable Max. length 4)	1000 m		1000 m	
Grounding connection PE (mm² / AWG)	50/0		50/0	
Control power supply	single phase, 230V, 50/60Hz,		single phase, 230V, 50/60Hz,	
Capacity of control power supply w/o options	1 kVA		1 kVA	
Capacity of control power supply with options	"depending on options to be used"		"depending on options to be used"	
Fan power supply	3-phase 400 Vac, 50Hz		3-phase 400 Vac, 50Hz	
Capacity of fan power supply (kVA) 5)	10		10	
Maintenance				
Maintenance access	Front		Front	
Cable entry 6)	Bottom in /Bottom out		Bottom in /Bottom out	
1) Values valid for synchronous motor and asynchronous motor. The specifications for the maximum motor shaft power is based on a motor efficiency of 95%. 2) Including the height of top cooling fans. 3) For CE products: Typical cable size values based on use of copper cables in cable tray laying. Incoming cable size is based on drive current rating. It has to be checked to be in accordance to mains short circuit capability and local and national electrical code requirement as well all other applicable regulations. 4) Variation in max. cable length may be possible depending on type cable and installation. For longer cable length between motor and drive contact Schneider Electric. 5) Contact Schneider Electric if N+1 redundancy cooling fan requested. 6) For other combination contact Schneider Electric.				

ATV6000C149A5555

ATV6000	C149A5555NA●	
Nominal data	Normal Duty	Heavy Duty
Type rating [kVA]	1490	
Max. Motor power [kW] / [HP] 1)	1190/1595	950/1273
Nominal Continuous output current [A] 1)	150	120
Max. output current with 120 %overload 1 min / 10 min [A]	180	/
Max. output current with 150 % overload 1 min / 10 min [A]	/	180
Power cells		
Number of cells per phase	5	
Power cell rated current [A]	150	
Power cell current with 120 %overload 1 min / 10 min [A]	180	
Max. output current for 3 sec [A]	225	
Characteristics with standard efficiency		
Efficiency at 100 % load (incl. Transformer) [%]	96.0%	
Total losses at 100 % load [kW]	51.8	41.4
Air flow [m ³ /h]	17100	
Noise level [dB (A)] @ 50 Hz	83	
Weight [kg / lb]	5236/11519	
Dimension [mm / inch] W*D*H 2)	3660*1500*2754/144.3*59.1*108.6	
Connection		
Incoming cable type	symmetrical three-phase	
Typical cable size (mm ² / AWG) 3)	95/000	
Motor cable type	symmetrical three-phase(Use of shielded cable is advisable)	
Typical cable size (mm ² / AWG) 3)	35/2	
Motor cable Max. length 4)	1000 m	
Grounding connection PE (mm ² / AWG)	50/0	
Control power supply	single phase, 230V, 50/60Hz,	
Capacity of control power supply w/o options	1 kVA	
Capacity of control power supply with options	"depending on options to be used"	
Fan power supply	3-phase 400 Vac, 50Hz	
Capacity of fan power supply (kVA) 5)	10	
Maintenance		
Maintenance access	Front	
Cable entry 6)	Bottom in /Bottom out	
<p>1) Values valid for synchronous motor and asynchronous motor. The specifications for the maximum motor shaft power is based on a motor efficiency of 95%.</p> <p>2) Including the height of top cooling fans.</p> <p>3) For CE products: Typical cable size values based on use of copper cables in cable tray laying. Incoming cable size is based on drive current rating. It has to be checked to be in accordance to mains short circuit capability and local and national electrical code requirement as well all other applicable regulations.</p> <p>4) Variation in max. cable length may be possible depending on type cable and installation. For longer cable length between motor and drive contact Schneider Electric.</p> <p>5) Contact Schneider Electric if N+1 redundancy cooling fan requested.</p> <p>6) For other combination contact Schneider Electric.</p>		

ATV6000C169A5555...ATV6000C278A5555

ATV6000	C169A5555NA●		C199A5555NA●	
Nominal data	Normal Duty	Heavy Duty	Normal Duty	Heavy Duty
Type rating [kVA]	1690		1990	
Max. Motor power [kW] / [HP] 1)	1350/1810	1270/1703	1590/2132	1270/1703
Nominal Continuous output current [A] 1)	170	160	200	160
Max. output current with 120 %overload 1 min / 10 min [A]	203	/	240	/
Max. output current with 150 % overload 1 min / 10 min [A]	/	240	/	240
Power cells				
Number of cells per phase	5		5	
Power cell rated current [A]	200		200	
Power cell current with 120 %overload 1 min / 10 min [A]	240		240	
Max. output current for 3 sec [A]	300		300	
Characteristics with standard efficiency				
Efficiency at 100 % load (incl. Transformer) [%]	96.0%		96.0%	
Total losses at 100 % load [kW]	58.7	55.3	69.1	55.3
Air flow [m³/h]	18912		18912	
Noise level [dB (A)] @ 50 Hz	80		80	
Weight [kg / lb]	6138/13504		6509/14320	
Dimension [mm / inch] W*D*H 2)	4660*1500*2754/ 183.7*59.1*108.6		4660*1500*2754/ 183.7*59.1*108.6	
Connection				
Incoming cable type	symmetrical three-phase		symmetrical three-phase	
Typical cable size (mm² / AWG) 3)	95/000		95/000	
Motor cable type	symmetrical three-phase(Use of shielded cable is advisable)		symmetrical three-phase(Use of shielded cable is advisable)	
Typical cable size (mm² / AWG) 3)	35/2		50/0	
Motor cable Max. length 4)	1000 m		1000 m	
Grounding connection PE (mm² / AWG)	50/0		50/0	
Control power supply	single phase, 230V, 50/60Hz,		single phase, 230V, 50/60Hz,	
Capacity of control power supply w/o options	1 kVA		1 kVA	
Capacity of control power supply with options	"depending on options to be used"		"depending on options to be used"	
Fan power supply	3-phase 400 Vac, 50Hz		3-phase 400 Vac, 50Hz	
Capacity of fan power supply (kVA) 5)	8		8	
Maintenance				
Maintenance access	Front		Front	
Cable entry 6)	Bottom in /Bottom out		Bottom in /Bottom out	

ATV6000	C219A5555NA●		C250A5555NA●	
	Normal Duty	Heavy Duty	Normal Duty	Heavy Duty
Nominal data				
Type rating [kVA]	2190		2500	
Max. Motor power [kW] / [HP] 1)	1750/2346	1400/1877	2000/2682	1780/2387
Nominal Continuous output current [A] 1)	220	176	251	224
Max. output current with 120 %overload 1 min / 10 min [A]	264	/	301	/
Max. output current with 150 % overload1 min / 10 min [A]	/	264	/	336
Power cells				
Number of cells per phase	5		5	
Power cell rated current [A]	220		280	
Power cell current with 120 %overload 1 min / 10 min [A]	264		336	
Max. output current for 3 sec [A]	330		420	
Characteristics with standard efficiency				
Efficiency at 100 % load (incl. Transformer) [%]	96.0%		96.0%	
Total losses at 100 % load [kW]	76.1	60.9	87.0	77.4
Air flow [m ³ /h]	18912		25440	
Noise level [dB (A)] @ 50 Hz	80		83	
Weight [kg / lb]	6757/14865		7223/15891	
Dimension [mm / inch] W*D*H 2)	4660*1500*2754/ 183.7*59.1*108.6		4660*1600*2754/ 183.7*63.1*108.6	
Connection				
Incoming cable type	symmetrical three-phase		symmetrical three-phase	
Typical cable size (mm ² / AWG) 3)	95/000		95/000	
Motor cable type	symmetrical three-phase(Use of shielded cable is advisable)		symmetrical three-phase(Use of shielded cable is advisable)	
Typical cable size (mm ² / AWG) 3)	70/00		70/00	
Motor cable Max. length 4)	1000 m		1000 m	
Grounding connection PE (mm ² / AWG)	50/0		50/0	
Control power supply	single phase, 230V, 50/60Hz,		single phase, 230V, 50/60Hz,	
Capacity of control power supply w/o options	1 kVA		1 kVA	
Capacity of control power supply with options	"depending on options to be used"		"depending on options to be used"	
Fan power supply	3-phase 400 Vac, 50Hz		3-phase 400 Vac, 50Hz	
Capacity of fan power supply (kVA) 5)	8		15	
Maintenance				
Maintenance access	Front		Front	
Cable entry 6)	Bottom in /Bottom out		Bottom in /Bottom out	

ATV6000	C278A5555NA●	
Nominal data	Normal Duty	Heavy Duty
Type rating [kVA]	2780	
Max. Motor power [kW] / [HP] 1)	2220/2977	1780/2387
Nominal Continuous output current [A] 1)	280	224
Max. output current with 120 %overload 1 min / 10 min [A]	336	/
Max. output current with 150 % overload 1 min / 10 min [A]	/	336
Power cells		
Number of cells per phase	5	
Power cell rated current [A]	280	
Power cell current with 120 %overload 1 min / 10 min [A]	336	
Max. output current for 3 sec [A]	420	
Characteristics with standard efficiency		
Efficiency at 100 % load (incl. Transformer) [%]	96.0%	
Total losses at 100 % load [kW]	96.5	77.4
Air flow [m³/h]	25440	
Noise level [dB (A)] @ 50 Hz	83	
Weight [kg / lb]	7570/16654	
Dimension [mm / inch] W*D*H 2)	4660*1600*2754/183.7*63.1*108.6	
Connection		
Incoming cable type	symmetrical three-phase	
Typical cable size (mm² / AWG) 3)	95/000	
Motor cable type	symmetrical three-phase(Use of shielded cable is advisable)	
Typical cable size (mm² / AWG) 3)	95/000	
Motor cable Max. length 4)	1000 m	
Grounding connection PE (mm² / AWG)	50/0	
Control power supply	single phase, 230V, 50/60Hz,	
Capacity of control power supply w/o options	1 kVA	
Capacity of control power supply with options	"depending on options to be used"	
Fan power supply	3-phase 400 Vac, 50Hz	
Capacity of fan power supply (kVA) 5)	15	
Maintenance		
Maintenance access	Front	
Cable entry 6)	Bottom in /Bottom out	
1) Values valid for synchronous motor and asynchronous motor. The specifications for the maximum motor shaft power is based on a motor efficiency of 95%. 2) Including the height of top cooling fans. 3) For CE products: Typical cable size values based on use of copper cables in cable tray laying. Incoming cable size is based on drive current rating. It has to be checked to be in accordance to mains short circuit capability and local and national electrical code requirement as well all other applicable regulations. 4) Variation in max. cable length may be possible depending on type cable and installation. For longer cable length between motor and drive contact Schneider Electric. 5) Contact Schneider Electric if N+1 redundancy cooling fan requested. 6) For other combination contact Schneider Electric.		

ATV6000C318A5555...ATV6000C408A5555

ATV6000	C318A5555NA●		C350A5555NA●	
Nominal data	Normal Duty	Heavy Duty	Normal Duty	Heavy Duty
Type rating [kVA]	3180		3500	
Max. Motor power [kW] / [HP] 1)	2540/3406	2030/2722	2800/3754	2610/3500
Nominal Continuous output current [A] 1)	320	256	352	328
Max. output current with 120 %overload 1 min / 10 min [A]	384	/	422	/
Max. output current with 150 % overload1 min / 10 min [A]	/	384	/	492
Power cells				
Number of cells per phase	5		5	
Power cell rated current [A]	320		410	
Power cell current with 120 %overload 1 min / 10 min [A]	384		492	
Max. output current for 3 sec [A]	480		615	
Characteristics with standard efficiency				
Efficiency at 100 % load (incl. Transformer) [%]	96.0%		96.0%	
Total losses at 100 % load [kW]	110.5	88.3	121.7	113.5
Air flow [m ³ /h]	22464		22464	
Noise level [dB (A)] @ 50 Hz	80		83	
Weight [kg / lb]	9776/21507		10172/22378	
Dimension [mm / inch] W*D*H 2)	5960*1700*2754/ 234.9*67*108.6		5960*1700*2754/ 234.9*67*108.6	
Connection				
Incoming cable type	symmetrical three-phase		symmetrical three-phase	
Typical cable size (mm ² / AWG) 3)	120/0000		150/300MCM	
Motor cable type	symmetrical three-phase(Use of shielded cable is advisable)		symmetrical three-phase(Use of shielded cable is advisable)	
Typical cable size (mm ² / AWG) 3)	120/0000		150/300MCM	
Motor cable Max. length 4)	1000 m		1000 m	
Grounding connection PE (mm ² / AWG)	50/0		70/00	
Control power supply	single phase, 230V, 50/60Hz,		single phase, 230V, 50/60Hz,	
Capacity of control power supply w/o options	1 kVA		1 kVA	
Capacity of control power supply with options	"depending on options to be used"		"depending on options to be used"	
Fan power supply	3-phase 400 Vac, 50Hz		3-phase 400 Vac, 50Hz	
Capacity of fan power supply (kVA) 5)	10		10	
Maintenance				
Maintenance access	Front		Front	
Cable entry 6)	Bottom in /Bottom out		Bottom in /Bottom out	

ATV6000	C375A5555NA●		C408A5555NA●	
Nominal data	Normal Duty	Heavy Duty	Normal Duty	Heavy Duty
Type rating [kVA]	3750		4080	
Max. Motor power [kW] / [HP] 1)	3000/4023	2610/3500	3260/4371	2610/3500
Nominal Continuous output current [A] 1)	377	328	410	328
Max. output current with 120 %overload 1 min / 10 min [A]	452	/	492	/
Max. output current with 150 % overload 1 min / 10 min [A]	/	492	/	492
Power cells				
Number of cells per phase	5		5	
Power cell rated current [A]	410		410	
Power cell current with 120 %overload 1 min / 10 min [A]	492		492	
Max. output current for 3 sec [A]	615		615	
Characteristics with standard efficiency				
Efficiency at 100 % load (incl. Transformer) [%]	96.0%		96.0%	
Total losses at 100 % load [kW]	130.4	113.5	141.7	113.5
Air flow [m³/h]	26184		26184	
Noise level [dB (A)] @ 50 Hz	83		83	
Weight [kg / lb]	10481/23058		10890/23958	
Dimension [mm / inch] W*D*H 2)	5960*1700*2754/ 234.9*67*108.6		5960*1700*2754/ 234.9*67*108.6	
Connection				
Incoming cable type	symmetrical three-phase		symmetrical three-phase	
Typical cable size (mm² / AWG) 3)	185/350MCM		185/350MCM	
Motor cable type	symmetrical three-phase(Use of shielded cable is advisable)		symmetrical three-phase(Use of shielded cable is advisable)	
Typical cable size (mm² / AWG) 3)	150/300MCM		185/350MCM	
Motor cable Max. length 4)	1000 m		1000 m	
Grounding connection PE (mm² / AWG)	70/00		70/00	
Control power supply	single phase, 230V, 50/60Hz,		single phase, 230V, 50/60Hz,	
Capacity of control power supply w/o options	1 kVA		1 kVA	
Capacity of control power supply with options	"depending on options to be used"		"depending on options to be used"	
Fan power supply	3-phase 400 Vac, 50Hz		3-phase 400 Vac, 50Hz	
Capacity of fan power supply (kVA) 5)	20		20	
Maintenance				
Maintenance access	Front		Front	
Cable entry 6)	Bottom in /Bottom out		Bottom in /Bottom out	
1) Values valid for synchronous motor and asynchronous motor. The specifications for the maximum motor shaft power is based on a motor efficiency of 95%. 2) Including the height of top cooling fans. 3) For CE products: Typical cable size values based on use of copper cables in cable tray laying. Incoming cable size is based on drive current rating. It has to be checked to be in accordance to mains short circuit capability and local and national electrical code requirement as well all other applicable regulations. 4) Variation in max. cable length may be possible depending on type cable and installation. For longer cable length between motor and drive contact Schneider Electric. 5) Contact Schneider Electric if N+1 redundancy cooling fan requested. 6) For other combination contact Schneider Electric.				

ATV6000C488A5555

ATV6000	C488A5555NA●	
Nominal data	Normal Duty	Heavy Duty
Type rating [kVA]	4880	
Max. Motor power [kW] / [HP] 1)	3900/5229	3120/4183
Nominal Continuous output current [A] 1)	490	392
Max. output current with 120 %overload 1 min / 10 min [A]	588	/
Max. output current with 150 % overload 1 min / 10 min [A]	/	588
Power cells		
Number of cells per phase	5	
Power cell rated current [A]	490	
Power cell current with 120 %overload 1 min / 10 min [A]	588	
Max. output current for 3 sec [A]	735	
Characteristics with standard efficiency		
Efficiency at 100 % load (incl. Transformer) [%]	96.0%	
Total losses at 100 % load [kW]	169.5	135.6
Air flow [m ³ /h]	29400	
Noise level [dB (A)] @ 50 Hz	83	
Weight [kg / lb]	11977/26349	
Dimension [mm / inch] W*D*H 2)	5960*1700*2795/234.9*67*110.2	
Connection		
Incoming cable type	symmetrical three-phase	
Typical cable size (mm ² / AWG) 3)	95*2/2*000	
Motor cable type	symmetrical three-phase(Use of shielded cable is advisable)	
Typical cable size (mm ² / AWG) 3)	240/500MCM	
Motor cable Max. length 4)	1000 m	
Grounding connection PE (mm ² / AWG)	95/000	
Control power supply	single phase, 230V, 50/60Hz,	
Capacity of control power supply w/o options	1 kVA	
Capacity of control power supply with options	"depending on options to be used"	
Fan power supply	3-phase 400 Vac, 50Hz	
Capacity of fan power supply (kVA) 5)	22	
Maintenance		
Maintenance access	Front	
Cable entry 6)	Bottom in /Bottom out	
<p>1) Values valid for synchronous motor and asynchronous motor. The specifications for the maximum motor shaft power is based on a motor efficiency of 95%.</p> <p>2) Including the height of top cooling fans.</p> <p>3) For CE products: Typical cable size values based on use of copper cables in cable tray laying. Incoming cable size is based on drive current rating. It has to be checked to be in accordance to mains short circuit capability and local and national electrical code requirement as well all other applicable regulations.</p> <p>4) Variation in max. cable length may be possible depending on type cable and installation. For longer cable length between motor and drive contact Schneider Electric.</p> <p>5) Contact Schneider Electric if N+1 redundancy cooling fan requested.</p> <p>6) For other combination contact Schneider Electric.</p>		

ATV6000C538A5555

ATV6000	C538A5555NA●	
Nominal data	Normal Duty	Heavy Duty
Type rating [kVA]	5380	
Max. Motor power [kW] / [HP] 1)	4300/5766	3500/4693
Nominal Continuous output current [A] 1)	550	440
Max. output current with 120 %overload 1 min / 10 min [A]	660	/
Max. output current with 150 % overload 1 min / 10 min [A]	/	660
Power cells		
Number of cells per phase	5	
Power cell rated current [A]	550	
Power cell current with 120 %overload 1 min / 10 min [A]	660	
Max. output current for 3 sec [A]	825	
Characteristics with standard efficiency		
Efficiency at 100 % load (incl. Transformer) [%]	96.5%	
Total losses at 100 % load [kW]	162.8	132.6
Air flow [m ³ /h]	42000	
Noise level [dB (A)] @ 50 Hz	85	
Weight [kg / lb]	15070/33154	
Dimension [mm / inch] W*D*H 2)	7660*1800*3155/301.9*71*124.4	
Connection		
Incoming cable type	symmetrical three-phase	
Typical cable size (mm ² / AWG) 3)	95*2/2*000	
Motor cable type	symmetrical three-phase(Use of shielded cable is advisable)	
Typical cable size (mm ² / AWG) 3)	95*2/2*000	
Motor cable Max. length 4)	1000 m	
Grounding connection PE (mm ² / AWG)	95/000	
Control power supply	single phase, 230V, 50/60Hz,	
Capacity of control power supply w/o options	1 kVA	
Capacity of control power supply with options	"depending on options to be used"	
Fan power supply	3-phase 400 Vac, 50Hz	
Capacity of fan power supply (kVA) 5)	32	
Maintenance		
Maintenance access	Front	
Cable entry 6)	Bottom in /Bottom out	
1) Values valid for synchronous motor and asynchronous motor. The specifications for the maximum motor shaft power is based on a motor efficiency of 95%. 2) Including the height of top cooling fans. 3) For CE products: Typical cable size values based on use of copper cables in cable tray laying. Incoming cable size is based on drive current rating. It has to be checked to be in accordance to mains short circuit capability and local and national electrical code requirement as well all other applicable regulations. 4) Variation in max. cable length may be possible depending on type cable and installation. For longer cable length between motor and drive contact Schneider Electric. 5) Contact Schneider Electric if N+1 redundancy cooling fan requested. 6) For other combination contact Schneider Electric.		

ATV6000C600A5555, ATV6000C663A5555

ATV6000	C600A5555NA●		C663A5555NA●	
Nominal data	Normal Duty	Heavy Duty	Normal Duty	Heavy Duty
Type rating [kVA]	6000		6630	
Max. Motor power [kW] / [HP] 1)	4800/6436	4580/6141	5300/7107	4580/6141
Nominal Continuous output current [A] 1)	603	576	666	576
Max. output current with 120 %overload 1 min / 10 min [A]	723	/	799	/
Max. output current with 150 % overload 1 min / 10 min [A]	/	864	/	864
Power cells				
Number of cells per phase	5		5	
Power cell rated current [A]	720		720	
Power cell current with 120 %overload 1 min / 10 min [A]	864		864	
Max. output current for 3 sec [A]	1080		1080	
Characteristics with standard efficiency				
Efficiency at 100 % load (incl. Transformer) [%]	96.5%		96.5%	
Total losses at 100 % load [kW]	181.7	173.4	200.6	173.4
Air flow [m ³ /h]	50400		50400	
Noise level [dB (A)] @ 50 Hz	85		85	
Weight [kg / lb]	15953/35097		16733/36813	
Dimension [mm / inch] W*D*H 2)	7960*1800*3155/ 313.7*71*124.4		7960*1800*3155/ 313.7*71*124.4	
Connection				
Incoming cable type	symmetrical three-phase		symmetrical three-phase	
Typical cable size (mm ² / AWG) 3)	120*2/2*0000		120*2/2*0000	
Motor cable type	symmetrical three-phase(Use of shielded cable is advisable)		symmetrical three-phase(Use of shielded cable is advisable)	
Typical cable size (mm ² / AWG) 3)	95*2/2*000		120*2/2*0000	
Motor cable Max. length 4)	1000 m		1000 m	
Grounding connection PE (mm ² / AWG)	120/0000		120/0000	
Control power supply	single phase, 230V, 50/60Hz,		single phase, 230V, 50/60Hz,	
Capacity of control power supply w/o options	1 kVA		1 kVA	
Capacity of control power supply with options	"depending on options to be used"		"depending on options to be used"	
Fan power supply	3-phase 400 Vac, 50Hz		3-phase 400 Vac, 50Hz	
Capacity of fan power supply (kVA) 5)	32		32	
Maintenance				
Maintenance access	Front & Rear		Front & Rear	
Cable entry 6)	Bottom in /Bottom out		Bottom in /Bottom out	
<p>1) Values valid for synchronous motor and asynchronous motor. The specifications for the maximum motor shaft power is based on a motor efficiency of 95%.</p> <p>2) Including the height of top cooling fans.</p> <p>3) For CE products: Typical cable size values based on use of copper cables in cable tray laying. Incoming cable size is based on drive current rating. It has to be checked to be in accordance to mains short circuit capability and local and national electrical code requirement as well all other applicable regulations.</p> <p>4) Variation in max. cable length may be possible depending on type cable and installation. For longer cable length between motor and drive contact Schneider Electric.</p> <p>5) Contact Schneider Electric if N+1 redundancy cooling fan requested.</p> <p>6) For other combination contact Schneider Electric.</p>				

ATV6000C717A5555...ATV6000M100A5555

ATV6000	C717A5555NA●		C775A5555NA●	
Nominal data	Normal Duty	Heavy Duty	Normal Duty	Heavy Duty
Type rating [kVA]	7170		7750	
Max. Motor power [kW] / [HP] 1)	5730/7684	4580/6141	6200/8314	5410/7254
Nominal Continuous output current [A] 1)	720	576	779	680
Max. output current with 120 %overload 1 min / 10 min [A]	864	/	934	/
Max. output current with 150 % overload1 min / 10 min [A]	/	864	/	1020
Power cells				
Number of cells per phase	5		5	
Power cell rated current [A]	720		850	
Power cell current with 120 %overload 1 min / 10 min [A]	864		1020	
Max. output current for 3 sec [A]	1080		1275	
Characteristics with standard efficiency				
Efficiency at 100 % load (incl. Transformer) [%]	96.5%		96.5%	
Total losses at 100 % load [kW]	216.9	173.4	234.7	204.8
Air flow [m³/h]	58091		60131	
Noise level [dB (A)] @ 50 Hz	85		85	
Weight [kg / lb]	17536/38579		18357/40385	
Dimension [mm / inch] W*D*H 2)	8260*1800*3155/ 325.5*71*124.4		8260*1800*3155/ 325.5*71*124.4	
Connection				
Incoming cable type	symmetrical three-phase		symmetrical three-phase	
Typical cable size (mm² / AWG) 3)	150*2/2*300MCM		185*2/2*350MCM	
Motor cable type	symmetrical three-phase(Use of shielded cable is advisable)		symmetrical three-phase(Use of shielded cable is advisable)	
Typical cable size (mm² / AWG) 3)	150*2/2*300MCM		240*2/2*500MCM	
Motor cable Max. length 4)	1000 m		1000 m	
Grounding connection PE (mm² / AWG)	120/0000		150/300MCM	
Control power supply	single phase, 230V, 50/60Hz,		single phase, 230V, 50/60Hz,	
Capacity of control power supply w/o options	1 kVA		1 kVA	
Capacity of control power supply with options	"depending on options to be used"		"depending on options to be used"	
Fan power supply	3-phase 400 Vac, 50Hz		3-phase 400 Vac, 50Hz	
Capacity of fan power supply (kVA) 5)	37		44	
Maintenance				
Maintenance access	Front & Rear		Front & Rear	
Cable entry 6)	Bottom in /Bottom out		Bottom in /Bottom out	

ATV6000	C845A5555NA●		C925A5555NA●	
Nominal data	Normal Duty	Heavy Duty	Normal Duty	Heavy Duty
Type rating [kVA]	8450		9250	
Max. Motor power [kW] / [HP] 1)	6760/9065	5410/7254	7400/9923	6370/8542
Nominal Continuous output current [A] 1)	850	680	929	800
Max. output current with 120 %overload 1 min / 10 min [A]	1020	/	1115	/
Max. output current with 150 % overload1 min / 10 min [A]	/	1020	/	1200
Power cells				
Number of cells per phase	5		5	
Power cell rated current [A]	850		1000	
Power cell current with 120 %overload 1 min / 10 min [A]	1020		1200	
Max. output current for 3 sec [A]	1275		1500	
Characteristics with standard efficiency				
Efficiency at 100 % load (incl. Transformer) [%]	96.5%		96.5%	
Total losses at 100 % load [kW]	255.9	204.8	280.1	241.2
Air flow [m ³ /h]	60131		60131	
Noise level [dB (A)] @ 50 Hz	85		85	
Weight [kg / lb]	19224/42293		20320/44704	
Dimension [mm / inch] W*D*H 2)	8260*1800*3155/ 325.5*71*124.4		8260*1800*3155/ 325.5*71*124.4	
Connection				
Incoming cable type	symmetrical three-phase		symmetrical three-phase	
Typical cable size (mm ² / AWG) 3)	240*2/2*500MCM		240*2/2*500MCM	
Motor cable type	symmetrical three-phase(Use of shielded cable is advisable)		symmetrical three-phase(Use of shielded cable is advisable)	
Typical cable size (mm ² / AWG) 3)	240*2/2*500MCM		240*2/2*500MCM	
Motor cable Max. length 4)	1000 m		1000 m	
Grounding connection PE (mm ² / AWG)	150/300MCM		185/350MCM	
Control power supply	single phase, 230V, 50/60Hz,		single phase, 230V, 50/60Hz,	
Capacity of control power supply w/o options	1 kVA		1 kVA	
Capacity of control power supply with options	"depending on options to be used"		"depending on options to be used"	
Fan power supply	3-phase 400 Vac, 50Hz		3-phase 400 Vac, 50Hz	
Capacity of fan power supply (kVA) 5)	44		44	
Maintenance				
Maintenance access	Front & Rear		Front & Rear	
Cable entry 6)	Bottom in /Bottom out		Bottom in /Bottom out	

ATV6000	M100A5555NA●	
Nominal data	Normal Duty	Heavy Duty
Type rating [kVA]	10000	
Max. Motor power [kW] / [HP] 1)	7960/10674	6370/8542
Nominal Continuous output current [A] 1)	1000	800
Max. output current with 120 %overload 1 min / 10 min [A]	1200	/
Max. output current with 150 % overload 1 min / 10 min [A]	/	1200
Power cells		
Number of cells per phase	5	
Power cell rated current [A]	1000	
Power cell current with 120 %overload 1 min / 10 min [A]	1200	
Max. output current for 3 sec [A]	1500	
Characteristics with standard efficiency		
Efficiency at 100 % load (incl. Transformer) [%]	96.5%	
Total losses at 100 % load [kW]	301.3	241.2
Air flow [m³/h]	60131	
Noise level [dB (A)] @ 50 Hz	85	
Weight [kg / lb]	21249/46748	
Dimension [mm / inch] W*D*H 2)	8260*1800*3155/325.5*71*124.4	
Connection		
Incoming cable type	symmetrical three-phase	
Typical cable size (mm² / AWG) 3)	150*3/3*300MCM	
Motor cable type	symmetrical three-phase(Use of shielded cable is advisable)	
Typical cable size (mm² / AWG) 3)	240*2/2*500MCM	
Motor cable Max. length 4)	1000 m	
Grounding connection PE (mm² / AWG)	185/350MCM	
Control power supply	single phase, 230V, 50/60Hz,	
Capacity of control power supply w/o options	1 kVA	
Capacity of control power supply with options	"depending on options to be used"	
Fan power supply	3-phase 400 Vac, 50Hz	
Capacity of fan power supply (kVA) 5)	44	
Maintenance		
Maintenance access	Front & Rear	
Cable entry 6)	Bottom in /Bottom out	
1) Values valid for synchronous motor and asynchronous motor. The specifications for the maximum motor shaft power is based on a motor efficiency of 95%. 2) Including the height of top cooling fans. 3) For CE products: Typical cable size values based on use of copper cables in cable tray laying. Incoming cable size is based on drive current rating. It has to be checked to be in accordance to mains short circuit capability and local and national electrical code requirement as well all other applicable regulations. 4) Variation in max. cable length may be possible depending on type cable and installation. For longer cable length between motor and drive contact Schneider Electric. 5) Contact Schneider Electric if N+1 redundancy cooling fan requested. 6) For other combination contact Schneider Electric.		

Layout Drawing and Dimensions

Layout Drawing

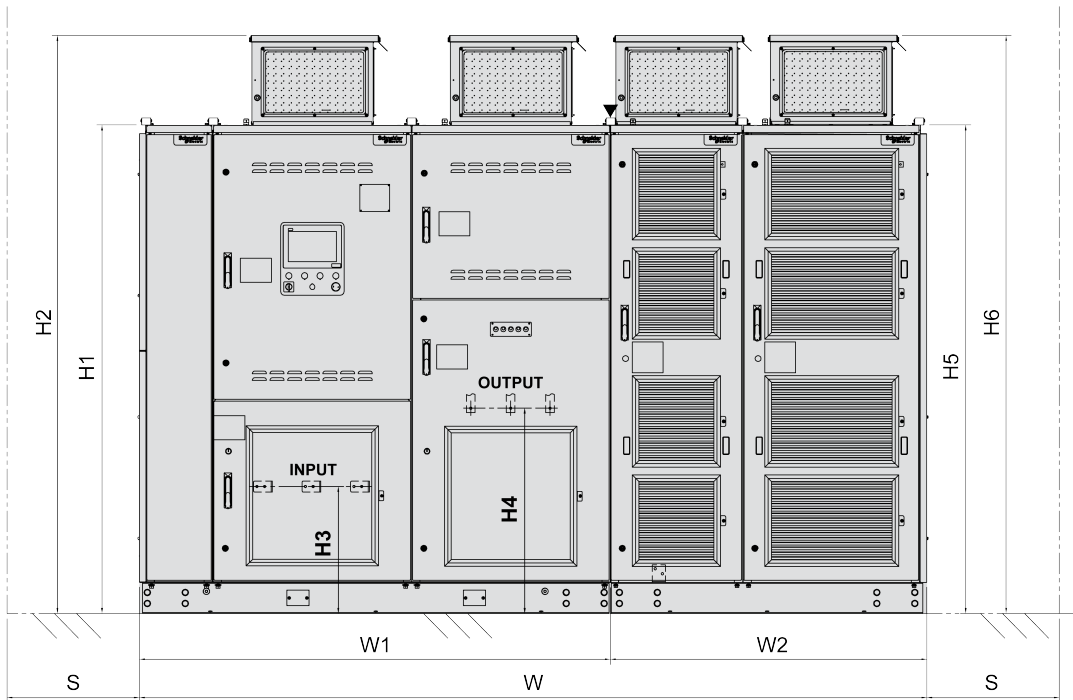

INPUT: Input terminal

OUTPUT: Output terminal

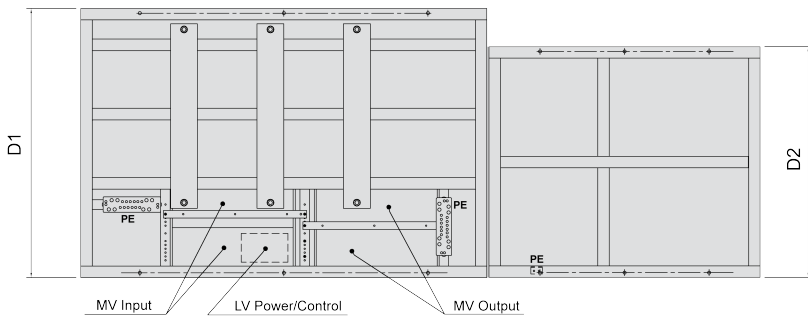

MV Input: MV Input cable area

LV Power/Control: LV Power/Control cable area

MV Output: MV Output cable area

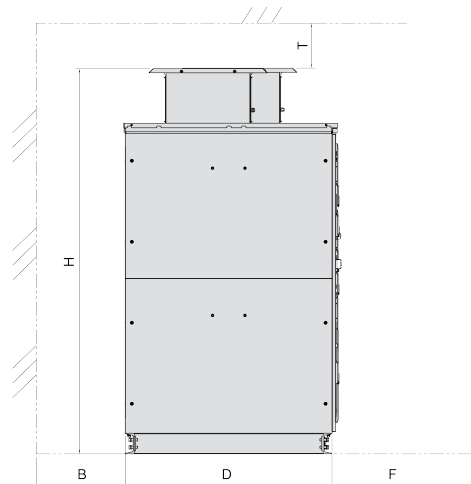

NOTE: Sketch is representing outline dimensions only, real cabinet arrangement is depending on power size.

Main dimensions - Output Voltage 5.5 kV

Product reference	Outer dimensions (mm / in)			Transformer cabinet			Powercell cabinet		
	W	H ^(b)	D	Fan Type	Fan Number	Weight [kg / lb]	Fan Type	Fan number	Weight [kg / lb]
ATV6000D450A5555...	2760	2618	1400	400	2	2291.4	500	1	844.7
	109	103	55			5041.1			1858.3
ATV6000D570A5555...	2760	2618	1400	400	2	2439.9	500	1	844.7
	109	103	55			5367.8			1858.3
ATV6000D640A5555...	2760	2618	1400	400	2	2526.6	500	1	844.7
	109	103	55			5558.5			1858.3
ATV6000D790A5555...	2760	2618	1400	400	2	2712.3	500	1	844.7
	109	103	55			5967.1			1858.3
ATV6000D890A5555...	2760	2618	1400	400	2	2836.1	500	1	844.7
	109	103	55			6239.4			1858.3
ATV6000D990A5555...	3060	2618	1400	450	2	3090.4	500	1	844.7
	120	103	55			6798.9			1858.3
ATV6000C113A5555...	3660	2618	1400	450	2	3263.7	500	2	1471
	144	103	55			7180.1			3236.2
ATV6000C132A5555...	3660	2618	1400	450	2	3499	500	2	1471
	144	103	55			7697.8			3236.2
ATV6000C149A5555...	3660	2754	1500	450	2	3764.7	500	2	1471
	144	108	59			8282.3			3236.2
ATV6000C169A5555...	4660	2754	1500	450	3	4135.1	400	3	2002
	183	108	59			9097.2			4404.4
ATV6000C194A5555...	4660	2754	1500	450	3	4506.5	400	3	2002
	183	108	59			9914.3			4404.4
ATV6000C219A5555...	4660	2754	1500	450	3	4754.2	400	3	2002
	183	108	59			10459.2			4404.4
ATV6000C250A5555...	4660	2754	1600	450	3	5178.4	500	3	2044.3
	183	108	63			11392.5			4497.5
ATV6000C278A5555...	4660	2754	1600	450	3	5525.1	500	3	2044.3
	183	108	63			12155.2			4497.5
ATV6000C318A5555...	5960	2754	1700	450	3	6081.9	400	5	3693.2
	235	108	67			13380.2			8125
ATV6000C350A5555...	5960	2754	1700	450	3	6478.1	400	5	3693.2
	235	108	67			14251.8			8125
ATV6000C375A5555...	5960	2795	1700	450	3	6787.6	400	5	3693.2
	235	110	67			14932.7			8125
ATV6000C408A5555...	5960	2795	1700	450	3	7196.2	400	5	3693.2
	235	110	67			15831.6			8125
ATV6000C488A5555...	5960	2795	1700	560	3	8301.3	450	5	3675.7
	235	110	67			18262.9			8086.5
ATV6000C538A5555...	7660	3155	1800	560	3	9330.2	500	5	5739.7
	302	124	71			20526.4			12627.3

Product reference	Outer dimensions (mm / in)			Transformer cabinet			Powercell cabinet		
	W	H ^(b)	D	Fan Type	Fan Number	Weight [kg / lb]	Fan Type	Fan number	Weight [kg / lb]
ATV6000C600A5555...	7960	3155	1800	560	3	10212.5	500	5	5739.7
	313	124	71			22467.5			12627.3
ATV6000C663A5555...	7960	3155	1800	560	3	10992.5	500	5	5739.7
	313	124	71			24183.5			12627.3
ATV6000C717A5555...	8260	3155	1800	560	4	11796.2	500	5	5739.7
	325	124	71			25951.6			12627.3
ATV6000C775A5555...	8260	3155	1800	560	4	12514.3	560	5	5842.7
	325	124	71			27531.5			12853.9
ATV6000C845A5555...	8260	3155	1800	560	4	13380.9	560	5	5842.7
	325	124	71			29438			12853.9
ATV6000C925A5555...	8260	3155	1800	560	4	14361.8	560	5	5957.7
	325	124	71			31596			13106.9
ATV6000M100A5555...	8260	3155	1800	560	4	15290.3	560	5	5957.7
	325	124	71			33638.7			13106.9

a) "H" is linked to higher size of transformer cabinet (H2) or transformer cabinet (H6).

Additional Dimensions - Output Voltage 5.5 kV

Product reference	Transformer Cabinet						Power cell Cabinet				Space Maintenance			
	(mm / in)						(mm / in)				(mm / in)			
	H1	H2	H3	H4	W1	D1	H5	H6	W2	D2	T	B (a)	F (b)	S (c)
ATV6000D450A5555...	2210	2540	500	780	1830	1400	2210	2618	930	1200	≥500	0	1500	0
	87	100	20	31	72	55	87	103	37	47	≥20		59	
ATV6000D570A5555...	2210	2540	500	780	1830	1400	2210	2618	930	1200	≥500	0	1500	0
	87	100	20	31	72	55	87	103	37	47	≥20		59	
ATV6000D640A5555...	2210	2540	500	780	1830	1400	2210	2618	930	1200	≥500	0	1500	0
	87	100	20	31	72	55	87	103	37	47	≥20		59	
ATV6000D790A5555...	2210	2540	500	780	1830	1400	2210	2618	930	1200	≥500	0	1500	0
	87	100	20	31	72	55	87	103	37	47	≥20		59	
ATV6000D890A5555...	2210	2540	500	780	1830	1400	2210	2618	930	1200	≥500	0	1500	0
	87	100	20	31	72	55	87	103	37	47	≥20		59	
ATV6000D990A5555...	2210	2604	500	780	2130	1400	2210	2618	930	1200	≥500	0	1500	0
	87	103	20	31	84	55	87	103	37	47	≥20		59	
ATV6000C113A5555...	2210	2604	500	780	2130	1400	2210	2618	1530	1200	≥500	0	1500	0
	87	103	20	31	84	55	87	103	60	47	≥20		59	
ATV6000C132A5555...	2210	2604	500	780	2130	1400	2210	2618	1530	1200	≥500	0	1500	0
	87	103	20	31	84	55	87	103	60	47	≥20		59	
ATV6000C149A5555...	2360	2754	500	930	2130	1500	2210	2618	1530	1200	≥500	0	1500	0
	93	108	20	37	84	59	87	103	60	47	≥20		59	
ATV6000C169A5555...	2360	2754	500	930	2430	1500	2210	2540	2230	1200	≥500	0	1500	0
	93	108	20	37	96	59	87	100	88	47	≥20		59	
ATV6000C194A5555...	2360	2754	500	930	2430	1500	2210	2540	2230	1200	≥500	0	1500	0
	93	108	20	37	96	59	87	100	88	47	≥20		59	
ATV6000C219A5555...	2360	2754	500	930	2430	1500	2210	2540	2230	1200	≥500	0	1500	0
	93	108	20	37	96	59	87	100	88	47	≥20		59	
ATV6000C250A5555...	2360	2754	500	930	2430	1600	2210	2618	2230	1200	≥500	0	1500	0
	93	108	20	37	96	63	87	103	88	47	≥20		59	
ATV6000C278A5555...	2360	2754	500	930	2430	1600	2210	2618	2230	1200	≥500	0	1500	0
	93	108	20	37	96	63	87	103	88	47	≥20		59	
ATV6000C318A5555...	2360	2754	500	930	2730	1700	2360	2690	3230	1200	≥500	0	1500	0
	93	108	20	37	107	67	93	106	127	47	≥20		59	
ATV6000C350A5555...	2360	2754	500	930	2730	1700	2360	2690	3230	1200	≥500	0	1500	0
	93	108	20	37	107	67	93	106	127	47	≥20		59	
ATV6000C375A5555...	2360	2754	500	930	2730	1700	2360	2690	3230	1200	≥500	0	1500	0
	93	108	20	37	107	67	93	106	127	47	≥20		59	
ATV6000C408A5555...	2360	2754	500	930	2730	1700	2360	2690	3230	1200	≥500	0	1500	0
	93	108	20	37	107	67	93	106	127	47	≥20		59	
ATV6000C488A5555...	2360	2795	500	930	2730	1700	2360	2754	3230	1200	≥500	0	1500	0
	93	110	20	37	107	67	93	108	127	47	≥20		59	
ATV6000C538A5555...	2720	3155	560	1290	3030	1800	2420	2828	4630	1400	≥500	0	1500	0
	107	124	22	51	119	71	95	111	182	55	≥20		59	

Product reference	Transformer Cabinet (mm / in)						Power cell Cabinet (mm / in)				Space Maintenance (mm / in)			
	H1	H2	H3	H4	W1	D1	H5	H6	W2	D2	T	B (a)	F (b)	S(c)
ATV6000C600A5555...	2720 107	3155 124	560 22	1290 51	3330 131	1800 71	2420 95	2828 111	4630 182	1400 55	≥500 ≥20	≥600 ≥24	1500 59	0
ATV6000C663A5555...	2720 107	3155 124	560 22	1290 51	3330 131	1800 71	2420 95	2828 111	4630 182	1400 55	≥500 ≥20	≥600 ≥24	1500 59	0
ATV6000C717A5555...	2720 107	3155 124	560 22	1290 51	3630 143	1800 71	2420 95	2828 111	4630 182	1400 55	≥500 ≥20	≥600 ≥24	1500 59	0
ATV6000C775A5555...	2720 107	3155 124	560 22	1290 51	3630 143	1800 71	2420 95	2855 112	4630 182	1400 55	≥500 ≥20	≥600 ≥24	1500 59	0
ATV6000C845A5555...	2720 107	3155 124	560 22	1290 51	3630 143	1800 71	2420 95	2855 112	4630 182	1400 55	≥500 ≥20	≥600 ≥24	1500 59	0
ATV6000C925A5555...	2720 107	3155 124	560 22	1290 51	3630 143	1800 71	2420 95	2855 112	4630 182	1600 63	≥500 ≥20	≥600 ≥24	1500 59	0
ATV6000M100A5555...	2720 107	3155 124	560 22	1290 51	3630 143	1800 71	2420 95	2855 112	4630 182	1600 63	≥500 ≥20	≥600 ≥24	1500 59	0

a) Space could be required for installation and lifting lugs.
b) For easy handling with power cell exchange tool 2000mm (78.7 in) are recommended.
c) Space (600mm) could be required for maintenance of the front & rear access drive.

Output Voltage 6 kV

ATV6000D450A6060...ATV6000D890A6060

ATV6000	D450A6060NA●		D570A6060NA●	
	Normal Duty	Heavy Duty	Normal Duty	Heavy Duty
Nominal data				
Type rating [kVA]	450		570	
Max. Motor power [kW] / [HP] 1)	355/476	330/442	450/603	420/563
Nominal Continuous output current [A] 1)	40.9	39	51.8	49
Max. output current with 120 %overload 1 min / 10 min [A]	49	/	62.1	/
Max. output current with 150 % overload 1 min / 10 min [A]	/	58.5	/	73.5
Power cells				
Number of cells per phase	5		5	
Power cell rated current [A]	65		65	
Power cell current with 120 %overload 1 min / 10 min [A]	78		78	
Max. output current for 3 sec [A]	97.5		97.5	
Characteristics with standard efficiency				
Efficiency at 100 % load (incl. Transformer) [%]	96.0%		96.0%	
Total losses at 100 % load [kW]	15.5	14.4	19.7	18.4
Air flow [m³/h]	9889		9889	
Noise level [dB (A)] @ 50 Hz	80		80	
Weight [kg / lb]	3137/6901		3285/7227	
Dimension [mm / inch] W*D*H 2)	2760*1400*2618/ 108.8*55.2*103.2		2760*1400*2618/ 108.8*55.2*103.2	
Connection				
Incoming cable type	symmetrical three-phase		symmetrical three-phase	
Typical cable size (mm² / AWG) 3)	95/000		95/000	
Motor cable type	symmetrical three-phase(Use of shielded cable is advisable)		symmetrical three-phase(Use of shielded cable is advisable)	
Typical cable size (mm² / AWG) 3)	25/4		25/4	
Motor cable Max. length 4)	1000 m		1000 m	
Grounding connection PE (mm² / AWG)	50/0		50/0	
Control power supply	single phase, 230V, 50/60Hz,		single phase, 230V, 50/60Hz,	
Capacity of control power supply w/o options	1 kVA		1 kVA	
Capacity of control power supply with options	"depending on options to be used"		"depending on options to be used"	
Fan power supply	3-phase 400 Vac, 50Hz		3-phase 400 Vac, 50Hz	
Capacity of fan power supply (kVA) 5)	6		6	
Maintenance				
Maintenance access	Front		Front	
Cable entry 6)	Bottom in /Bottom out		Bottom in /Bottom out	

ATV6000	D700A6060NA●		D790A6060NA●	
	Normal Duty	Heavy Duty	Normal Duty	Heavy Duty
Nominal data				
Type rating [kVA]	700		790	
Max. Motor power [kW] / [HP] 1)	560/750	450/603	630/844	590/791
Nominal Continuous output current [A] 1)	65	52	72.5	69
Max. output current with 120 %overload 1 min / 10 min [A]	78	/	87	/
Max. output current with 150 % overload1 min / 10 min [A]	/	78	/	104
Power cells				
Number of cells per phase	5		5	
Power cell rated current [A]	65		100	
Power cell current with 120 %overload 1 min / 10 min [A]	78		120	
Max. output current for 3 sec [A]	97.5		150	
Characteristics with standard efficiency				
Efficiency at 100 % load (incl. Transformer) [%]	96.0%		96.0%	
Total losses at 100 % load [kW]	24.4	19.7	27.4	25.7
Air flow [m ³ /h]	9889		9889	
Noise level [dB (A)] @ 50 Hz	80		80	
Weight [kg / lb]	3446/7581		3558/7828	
Dimension [mm / inch] W*D*H 2)	2760*1400*2618/ 108.8*55.2*103.2		2760*1400*2618/ 108.8*55.2*103.2	
Connection				
Incoming cable type	symmetrical three-phase		symmetrical three-phase	
Typical cable size (mm ² / AWG) 3)	95/000		95/000	
Motor cable type	symmetrical three-phase(Use of shielded cable is advisable)		symmetrical three-phase(Use of shielded cable is advisable)	
Typical cable size (mm ² / AWG) 3)	25/4		25/4	
Motor cable Max. length 4)	1000 m		1000 m	
Grounding connection PE (mm ² / AWG)	50/0		50/0	
Control power supply	single phase, 230V, 50/60Hz,		single phase, 230V, 50/60Hz,	
Capacity of control power supply w/o options	1 kVA		1 kVA	
Capacity of control power supply with options	"depending on options to be used"		"depending on options to be used"	
Fan power supply	3-phase 400 Vac, 50Hz		3-phase 400 Vac, 50Hz	
Capacity of fan power supply (kVA) 5)	6		6	
Maintenance				
Maintenance access	Front		Front	
Cable entry 6)	Bottom in /Bottom out		Bottom in /Bottom out	

ATV6000	D890A6060NA●	
Nominal data	Normal Duty	Heavy Duty
Type rating [kVA]	890	
Max. Motor power [kW] / [HP] 1)	710/952	670/898
Nominal Continuous output current [A] 1)	81.7	78
Max. output current with 120 %overload 1 min / 10 min [A]	98	/
Max. output current with 150 % overload 1 min / 10 min [A]	/	117
Power cells		
Number of cells per phase	5	
Power cell rated current [A]	100	
Power cell current with 120 %overload 1 min / 10 min [A]	120	
Max. output current for 3 sec [A]	150	
Characteristics with standard efficiency		
Efficiency at 100 % load (incl. Transformer) [%]	96.0%	
Total losses at 100 % load [kW]	30.9	29.2
Air flow [m ³ /h]	9889	
Noise level [dB (A)] @ 50 Hz	80	
Weight [kg / lb]	3681/8098	
Dimension [mm / inch] W*D*H 2)	2760*1400*2618/108.8*55.2*103.2	
Connection		
Incoming cable type	symmetrical three-phase	
Typical cable size (mm ² / AWG) 3)	95/000	
Motor cable type	symmetrical three-phase(Use of shielded cable is advisable)	
Typical cable size (mm ² / AWG) 3)	25/4	
Motor cable Max. length 4)	1000 m	
Grounding connection PE (mm ² / AWG)	50/0	
Control power supply	single phase, 230V, 50/60Hz,	
Capacity of control power supply w/o options	1 kVA	
Capacity of control power supply with options	"depending on options to be used"	
Fan power supply	3-phase 400 Vac, 50Hz	
Capacity of fan power supply (kVA) 5)	6	
Maintenance		
Maintenance access	Front	
Cable entry 6)	Bottom in /Bottom out	
<p>1) Values valid for synchronous motor and asynchronous motor. The specifications for the maximum motor shaft power is based on a motor efficiency of 95%.</p> <p>2) Including the height of top cooling fans.</p> <p>3) For CE products: Typical cable size values based on use of copper cables in cable tray laying. Incoming cable size is based on drive current rating. It has to be checked to be in accordance to mains short circuit capability and local and national electrical code requirement as well all other applicable regulations.</p> <p>4) Variation in max. cable length may be possible depending on type cable and installation. For longer cable length between motor and drive contact Schneider Electric.</p> <p>5) Contact Schneider Electric if N+1 redundancy cooling fan requested.</p> <p>6) For other combination contact Schneider Electric.</p>		

ATV6000C108A6060

ATV6000	C108A6060NA•	
Nominal data	Normal Duty	Heavy Duty
Type rating [kVA]	1080	
Max. Motor power [kW] / [HP] 1)	860/1153	690/925
Nominal Continuous output current [A] 1)	100	80
Max. output current with 120 %overload 1 min / 10 min [A]	120	/
Max. output current with 150 % overload 1 min / 10 min [A]	/	120
Power cells		
Number of cells per phase	5	
Power cell rated current [A]	100	
Power cell current with 120 %overload 1 min / 10 min [A]	120	
Max. output current for 3 sec [A]	150	
Characteristics with standard efficiency		
Efficiency at 100 % load (incl. Transformer) [%]	96.0%	
Total losses at 100 % load [kW]	37.4	30.1
Air flow [m ³ /h]	11940	
Noise level [dB (A)] @ 50 Hz	80	
Weight [kg / lb]	4047/8903	
Dimension [mm / inch] W*D*H 2)	3060*1400*2618/120.6*55.2*103.2	
Connection		
Incoming cable type	symmetrical three-phase	
Typical cable size (mm ² / AWG) 3)	95/000	
Motor cable type	symmetrical three-phase(Use of shielded cable is advisable)	
Typical cable size (mm ² / AWG) 3)	25/4	
Motor cable Max. length 4)	1000 m	
Grounding connection PE (mm ² / AWG)	50/0	
Control power supply	single phase, 230V, 50/60Hz,	
Capacity of control power supply w/o options	1 kVA	
Capacity of control power supply with options	"depending on options to be used"	
Fan power supply	3-phase 400 Vac, 50Hz	
Capacity of fan power supply (kVA) 5)	7	
Maintenance		
Maintenance access	Front	
Cable entry 6)	Bottom in /Bottom out	
<p>1) Values valid for synchronous motor and asynchronous motor. The specifications for the maximum motor shaft power is based on a motor efficiency of 95%.</p> <p>2) Including the height of top cooling fans.</p> <p>3) For CE products: Typical cable size values based on use of copper cables in cable tray laying. Incoming cable size is based on drive current rating. It has to be checked to be in accordance to mains short circuit capability and local and national electrical code requirement as well all other applicable regulations.</p> <p>4) Variation in max. cable length may be possible depending on type cable and installation. For longer cable length between motor and drive contact Schneider Electric.</p> <p>5) Contact Schneider Electric if N+1 redundancy cooling fan requested.</p> <p>6) For other combination contact Schneider Electric.</p>		

ATV6000C125A6060...ATV6000C138A6060

ATV6000	C125A6060NA●		C138A6060NA●	
Nominal data	Normal Duty	Heavy Duty	Normal Duty	Heavy Duty
Type rating [kVA]	1250		1380	
Max. Motor power [kW] / [HP] 1)	1000/1341	950/1273	1100/1475	1040/1394
Nominal Continuous output current [A] 1)	115	110	127	120
Max. output current with 120 %overload 1 min / 10 min [A]	138	/	152	/
Max. output current with 150 % overload 1 min / 10 min [A]	/	165	/	180
Power cells				
Number of cells per phase	5		5	
Power cell rated current [A]	150		150	
Power cell current with 120 %overload 1 min / 10 min [A]	180		180	
Max. output current for 3 sec [A]	225		225	
Characteristics with standard efficiency				
Efficiency at 100 % load (incl. Transformer) [%]	96.0%		96.0%	
Total losses at 100 % load [kW]	43.6	41.4	47.9	45.2
Air flow [m³/h]	17100		17100	
Noise level [dB (A)] @ 50 Hz	83		83	
Weight [kg / lb]	4884/10745		5045/11099	
Dimension [mm / inch] W*D*H 2)	3660*1400*2618/ 144.3*55.2*103.2		3660*1400*2618/ 144.3*55.2*103.2	
Connection				
Incoming cable type	symmetrical three-phase		symmetrical three-phase	
Typical cable size (mm² / AWG) 3)	95/000		95/000	
Motor cable type	symmetrical three-phase(Use of shielded cable is advisable)		symmetrical three-phase(Use of shielded cable is advisable)	
Typical cable size (mm² / AWG) 3)	35/2		35/2	
Motor cable Max. length 4)	1000 m		1000 m	
Grounding connection PE (mm² / AWG)	50/0		50/0	
Control power supply	single phase, 230V, 50/60Hz,		single phase, 230V, 50/60Hz,	
Capacity of control power supply w/o options	1 kVA		1 kVA	
Capacity of control power supply with options	"depending on options to be used"		"depending on options to be used"	
Fan power supply	3-phase 400 Vac, 50Hz		3-phase 400 Vac, 50Hz	
Capacity of fan power supply (kVA) 5)	10		10	
Maintenance				
Maintenance access	Front		Front	
Cable entry 6)	Bottom in /Bottom out		Bottom in /Bottom out	
1) Values valid for synchronous motor and asynchronous motor. The specifications for the maximum motor shaft power is based on a motor efficiency of 95%. 2) Including the height of top cooling fans. 3) For CE products: Typical cable size values based on use of copper cables in cable tray laying. Incoming cable size is based on drive current rating. It has to be checked to be in accordance to mains short circuit capability and local and national electrical code requirement as well all other applicable regulations. 4) Variation in max. cable length may be possible depending on type cable and installation. For longer cable length between motor and drive contact Schneider Electric. 5) Contact Schneider Electric if N+1 redundancy cooling fan requested. 6) For other combination contact Schneider Electric.				

ATV6000C163A6060

ATV6000	C163A6060NA●	
Nominal data	Normal Duty	Heavy Duty
Type rating [kVA]	1630	
Max. Motor power [kW] / [HP] 1)	1300/1743	1040/1394
Nominal Continuous output current [A] 1)	150	120
Max. output current with 120 %overload 1 min / 10 min [A]	180	/
Max. output current with 150 % overload 1 min / 10 min [A]	/	180
Power cells		
Number of cells per phase	5	
Power cell rated current [A]	150	
Power cell current with 120 %overload 1 min / 10 min [A]	180	
Max. output current for 3 sec [A]	225	
Characteristics with standard efficiency		
Efficiency at 100 % load (incl. Transformer) [%]	96.0%	
Total losses at 100 % load [kW]	56.6	45.2
Air flow [m ³ /h]	17100	
Noise level [dB (A)] @ 50 Hz	83	
Weight [kg / lb]	5409/11900	
Dimension [mm / inch] W*D*H 2)	3660*1500*2754/144.3*59.1*108.6	
Connection		
Incoming cable type	symmetrical three-phase	
Typical cable size (mm ² / AWG) 3)	95/000	
Motor cable type	symmetrical three-phase(Use of shielded cable is advisable)	
Typical cable size (mm ² / AWG) 3)	35/2	
Motor cable Max. length 4)	1000 m	
Grounding connection PE (mm ² / AWG)	50/0	
Control power supply	single phase, 230V, 50/60Hz,	
Capacity of control power supply w/o options	1 kVA	
Capacity of control power supply with options	"depending on options to be used"	
Fan power supply	3-phase 400 Vac, 50Hz	
Capacity of fan power supply (kVA) 5)	10	
Maintenance		
Maintenance access	Front	
Cable entry 6)	Bottom in /Bottom out	
<p>1) Values valid for synchronous motor and asynchronous motor. The specifications for the maximum motor shaft power is based on a motor efficiency of 95%.</p> <p>2) Including the height of top cooling fans.</p> <p>3) For CE products: Typical cable size values based on use of copper cables in cable tray laying. Incoming cable size is based on drive current rating. It has to be checked to be in accordance to mains short circuit capability and local and national electrical code requirement as well all other applicable regulations.</p> <p>4) Variation in max. cable length may be possible depending on type cable and installation. For longer cable length between motor and drive contact Schneider Electric.</p> <p>5) Contact Schneider Electric if N+1 redundancy cooling fan requested.</p> <p>6) For other combination contact Schneider Electric.</p>		

ATV6000C188A6060...ATV6000C239A6060

ATV6000	C188A6060NA●		C213A6060NA●	
Nominal data	Normal Duty	Heavy Duty	Normal Duty	Heavy Duty
Type rating [kVA]	1880		2130	
Max. Motor power [kW] / [HP] 1)	1500/2011	1390/1864	1700/2279	1390/1864
Nominal Continuous output current [A] 1)	173	160	196	160
Max. output current with 120 %overload 1 min / 10 min [A]	207	/	235	/
Max. output current with 150 % overload1 min / 10 min [A]	/	240	/	240
Power cells				
Number of cells per phase	5		5	
Power cell rated current [A]	200		200	
Power cell current with 120 %overload 1 min / 10 min [A]	240		240	
Max. output current for 3 sec [A]	300		300	
Characteristics with standard efficiency				
Efficiency at 100 % load (incl. Transformer) [%]	96.0%		96.0%	
Total losses at 100 % load [kW]	65.3	60.4	73.9	60.4
Air flow [m³/h]	18912		18912	
Noise level [dB (A)] @ 50 Hz	80		80	
Weight [kg / lb]	6373/14021		6682/14700	
Dimension [mm / inch] W*D*H 2)	4660*1500*2754/ 183.7*59.1*108.6		4660*1500*2754/ 183.7*59.1*108.6	
Connection				
Incoming cable type	symmetrical three-phase		symmetrical three-phase	
Typical cable size (mm² / AWG) 3)	95/000		95/000	
Motor cable type	symmetrical three-phase(Use of shielded cable is advisable)		symmetrical three-phase(Use of shielded cable is advisable)	
Typical cable size (mm² / AWG) 3)	35/2		50/0	
Motor cable Max. length 4)	1000 m		1000 m	
Grounding connection PE (mm² / AWG)	50/0		50/0	
Control power supply	single phase, 230V, 50/60Hz,		single phase, 230V, 50/60Hz,	
Capacity of control power supply w/o options	1 kVA		1 kVA	
Capacity of control power supply with options	"depending on options to be used"		"depending on options to be used"	
Fan power supply	3-phase 400 Vac, 50Hz		3-phase 400 Vac, 50Hz	
Capacity of fan power supply (kVA) 5)	8		8	
Maintenance				
Maintenance access	Front		Front	
Cable entry 6)	Bottom in /Bottom out		Bottom in /Bottom out	

ATV6000	C239A6060NA●	
Nominal data	Normal Duty	Heavy Duty
Type rating [kVA]	2390	
Max. Motor power [kW] / [HP] 1)	1910/2561	1520/2038
Nominal Continuous output current [A] 1)	220	176
Max. output current with 120 %overload 1 min / 10 min [A]	264	/
Max. output current with 150 % overload1 min / 10 min [A]	/	264
Power cells		
Number of cells per phase	5	
Power cell rated current [A]	220	
Power cell current with 120 %overload 1 min / 10 min [A]	264	
Max. output current for 3 sec [A]	330	
Characteristics with standard efficiency		
Efficiency at 100 % load (incl. Transformer) [%]	96.0%	
Total losses at 100 % load [kW]	83.1	66.1
Air flow [m ³ /h]	18912	
Noise level [dB (A)] @ 50 Hz	80	
Weight [kg / lb]	7004/15409	
Dimension [mm / inch] W*D*H 2)	4660*1500*2754/183.7*59.1*108.6	
Connection		
Incoming cable type	symmetrical three-phase	
Typical cable size (mm ² / AWG) 3)	95/000	
Motor cable type	symmetrical three-phase(Use of shielded cable is advisable)	
Typical cable size (mm ² / AWG) 3)	70/00	
Motor cable Max. length 4)	1000 m	
Grounding connection PE (mm ² / AWG)	50/0	
Control power supply	single phase, 230V, 50/60Hz,	
Capacity of control power supply w/o options	1 kVA	
Capacity of control power supply with options	"depending on options to be used"	
Fan power supply	3-phase 400 Vac, 50Hz	
Capacity of fan power supply (kVA) 5)	8	
Maintenance		
Maintenance access	Front	
Cable entry 6)	Bottom in /Bottom out	
<p>1) Values valid for synchronous motor and asynchronous motor. The specifications for the maximum motor shaft power is based on a motor efficiency of 95%.</p> <p>2) Including the height of top cooling fans.</p> <p>3) For CE products: Typical cable size values based on use of copper cables in cable tray laying. Incoming cable size is based on drive current rating. It has to be checked to be in accordance to mains short circuit capability and local and national electrical code requirement as well all other applicable regulations.</p> <p>4) Variation in max. cable length may be possible depending on type cable and installation. For longer cable length between motor and drive contact Schneider Electric.</p> <p>5) Contact Schneider Electric if N+1 redundancy cooling fan requested.</p> <p>6) For other combination contact Schneider Electric.</p>		

ATV6000C263A6060...ATV6000C304A6060

ATV6000	C263A6060NA●		C304A6060NA●	
Nominal data	Normal Duty	Heavy Duty	Normal Duty	Heavy Duty
Type rating [kVA]	2630		3040	
Max. Motor power [kW] / [HP] 1)	2100/2816	1940/2601	2430/3258	1940/2601
Nominal Continuous output current [A] 1)	242	224	280	224
Max. output current with 120 %overload 1 min / 10 min [A]	290	/	336	/
Max. output current with 150 % overload 1 min / 10 min [A]	/	336	/	336
Power cells				
Number of cells per phase	5		5	
Power cell rated current [A]	280		280	
Power cell current with 120 %overload 1 min / 10 min [A]	336		336	
Max. output current for 3 sec [A]	420		420	
Characteristics with standard efficiency				
Efficiency at 100 % load (incl. Transformer) [%]	96.0%		96.0%	
Total losses at 100 % load [kW]	91.3	84.3	105.6	84.3
Air flow [m³/h]	25440		25440	
Noise level [dB (A)] @ 50 Hz	83		83	
Weight [kg / lb]	7384/16245		7892/17362	
Dimension [mm / inch] W*D*H 2)	4660*1600*2754/ 183.7*63.1*108.6		4660*1600*2754/ 183.7*63.1*108.6	
Connection				
Incoming cable type	symmetrical three-phase		symmetrical three-phase	
Typical cable size (mm² / AWG) 3)	95/000		95/000	
Motor cable type	symmetrical three-phase(Use of shielded cable is advisable)		symmetrical three-phase(Use of shielded cable is advisable)	
Typical cable size (mm² / AWG) 3)	70/00		95/000	
Motor cable Max. length 4)	1000 m		1000 m	
Grounding connection PE (mm² / AWG)	50/0		50/0	
Control power supply	single phase, 230V, 50/60Hz,		single phase, 230V, 50/60Hz,	
Capacity of control power supply w/o options	1 kVA		1 kVA	
Capacity of control power supply with options	"depending on options to be used"		"depending on options to be used"	
Fan power supply	3-phase 400 Vac, 50Hz		3-phase 400 Vac, 50Hz	
Capacity of fan power supply (kVA) 5)	15		15	
Maintenance				
Maintenance access	Front		Front	
Cable entry 6)	Bottom in /Bottom out		Bottom in /Bottom out	
1) Values valid for synchronous motor and asynchronous motor. The specifications for the maximum motor shaft power is based on a motor efficiency of 95%. 2) Including the height of top cooling fans. 3) For CE products: Typical cable size values based on use of copper cables in cable tray laying. Incoming cable size is based on drive current rating. It has to be checked to be in accordance to mains short circuit capability and local and national electrical code requirement as well all other applicable regulations. 4) Variation in max. cable length may be possible depending on type cable and installation. For longer cable length between motor and drive contact Schneider Electric. 5) Contact Schneider Electric if N+1 redundancy cooling fan requested. 6) For other combination contact Schneider Electric.				

ATV6000C348A6060...ATV6000C375A6060

ATV6000	C348A6060NA●		C375A6060NA●	
Nominal data	Normal Duty	Heavy Duty	Normal Duty	Heavy Duty
Type rating [kVA]	3480		3750	
Max. Motor power [kW] / [HP] 1)	2780/3728	2220/2977	3000/4023	2840/3808
Nominal Continuous output current [A] 1)	320	256	345	328
Max. output current with 120 %overload 1 min / 10 min [A]	384	/	414	/
Max. output current with 150 % overload 1 min / 10 min [A]	/	384	/	492
Power cells				
Number of cells per phase	5		5	
Power cell rated current [A]	320		410	
Power cell current with 120 %overload 1 min / 10 min [A]	384		492	
Max. output current for 3 sec [A]	480		615	
Characteristics with standard efficiency				
Efficiency at 100 % load (incl. Transformer) [%]	96.0%		96.0%	
Total losses at 100 % load [kW]	120.8	96.5	130.4	123.5
Air flow [m ³ /h]	22464		22464	
Noise level [dB (A)] @ 50 Hz	83		83	
Weight [kg / lb]	10147/22323		10481/23058	
Dimension [mm / inch] W*D*H 2)	5960*1700*2754/ 234.9*67*108.6		5960*1700*2754/ 234.9*67*108.6	
Connection				
Incoming cable type	symmetrical three-phase		symmetrical three-phase	
Typical cable size (mm ² / AWG) 3)	120/0000		150/300MCM	
Motor cable type	symmetrical three-phase(Use of shielded cable is advisable)		symmetrical three-phase(Use of shielded cable is advisable)	
Typical cable size (mm ² / AWG) 3)	120/0000		120/0000	
Motor cable Max. length 4)	1000 m		1000 m	
Grounding connection PE (mm ² / AWG)	50/0		70/00	
Control power supply	single phase, 230V, 50/60Hz,		single phase, 230V, 50/60Hz,	
Capacity of control power supply w/o options	1 kVA		1 kVA	
Capacity of control power supply with options	"depending on options to be used"		"depending on options to be used"	
Fan power supply	3-phase 400 Vac, 50Hz		3-phase 400 Vac, 50Hz	
Capacity of fan power supply (kVA) 5)	10		10	
Maintenance				
Maintenance access	Front		Front	
Cable entry 6)	Bottom in /Bottom out		Bottom in /Bottom out	
<p>1) Values valid for synchronous motor and asynchronous motor. The specifications for the maximum motor shaft power is based on a motor efficiency of 95%.</p> <p>2) Including the height of top cooling fans.</p> <p>3) For CE products: Typical cable size values based on use of copper cables in cable tray laying. Incoming cable size is based on drive current rating. It has to be checked to be in accordance to mains short circuit capability and local and national electrical code requirement as well all other applicable regulations.</p> <p>4) Variation in max. cable length may be possible depending on type cable and installation. For longer cable length between motor and drive contact Schneider Electric.</p> <p>5) Contact Schneider Electric if N+1 redundancy cooling fan requested.</p> <p>6) For other combination contact Schneider Electric.</p>				

ATV6000C413A6060...ATV6000C532A6060

ATV6000	C413A6060NA●		C445A6060NA●	
Nominal data	Normal Duty	Heavy Duty	Normal Duty	Heavy Duty
Type rating [kVA]	4130		4450	
Max. Motor power [kW] / [HP] 1)	3300/4425	2840/3808	3560/4774	2840/3808
Nominal Continuous output current [A] 1)	380	328	410	328
Max. output current with 120 %overload 1 min / 10 min [A]	456	/	492	/
Max. output current with 150 % overload1 min / 10 min [A]	/	492	/	492
Power cells				
Number of cells per phase	5		5	
Power cell rated current [A]	410		410	
Power cell current with 120 %overload 1 min / 10 min [A]	492		492	
Max. output current for 3 sec [A]	615		615	
Characteristics with standard efficiency				
Efficiency at 100 % load (incl. Transformer) [%]	96.0%		96.0%	
Total losses at 100 % load [kW]	143.4	123.5	154.7	123.5
Air flow [m³/h]	26184		26184	
Noise level [dB (A)] @ 50 Hz	83		83	
Weight [kg / lb]	10952/24094		11348/24966	
Dimension [mm / inch] W*D*H 2)	5960*1700*2754/ 234.9*67*108.6		5960*1700*2754/ 234.9*67*108.6	
Connection				
Incoming cable type	symmetrical three-phase		symmetrical three-phase	
Typical cable size (mm² / AWG) 3)	185/350MCM		185/350MCM	
Motor cable type	symmetrical three-phase(Use of shielded cable is advisable)		symmetrical three-phase(Use of shielded cable is advisable)	
Typical cable size (mm² / AWG) 3)	150/300MCM		185/350MCM	
Motor cable Max. length 4)	1000 m		1000 m	
Grounding connection PE (mm² / AWG)	70/00		70/00	
Control power supply	single phase, 230V, 50/60Hz,		single phase, 230V, 50/60Hz,	
Capacity of control power supply w/o options	1 kVA		1 kVA	
Capacity of control power supply with options	"depending on options to be used"		"depending on options to be used"	
Fan power supply	3-phase 400 Vac, 50Hz		3-phase 400 Vac, 50Hz	
Capacity of fan power supply (kVA) 5)	20		20	
Maintenance				
Maintenance access	Front		Front	
Cable entry 6)	Bottom in /Bottom out		Bottom in /Bottom out	

ATV6000	C532A6060NA●	
Nominal data	Normal Duty	Heavy Duty
Type rating [kVA]	5320	
Max. Motor power [kW] / [HP] 1)	4250/5699	3400/4559
Nominal Continuous output current [A] 1)	490	392
Max. output current with 120 %overload 1 min / 10 min [A]	588	/
Max. output current with 150 % overload1 min / 10 min [A]	/	588
Power cells		
Number of cells per phase	5	
Power cell rated current [A]	490	
Power cell current with 120 %overload 1 min / 10 min [A]	588	
Max. output current for 3 sec [A]	735	
Characteristics with standard efficiency		
Efficiency at 100 % load (incl. Transformer) [%]	96.5%	
Total losses at 100 % load [kW]	160.9	128.8
Air flow [m ³ /h]	29400	
Noise level [dB (A)] @ 50 Hz	83	
Weight [kg / lb]	12522/27548	
Dimension [mm / inch] W*D*H 2)	5960*1700*2795/234.9*67*110.2	
Connection		
Incoming cable type	symmetrical three-phase	
Typical cable size (mm ² / AWG) 3)	95*2/2*00	
Motor cable type	symmetrical three-phase(Use of shielded cable is advisable)	
Typical cable size (mm ² / AWG) 3)	240/500MCM	
Motor cable Max. length 4)	1000 m	
Grounding connection PE (mm ² / AWG)	95/000	
Control power supply	single phase, 230V, 50/60Hz,	
Capacity of control power supply w/o options	1 kVA	
Capacity of control power supply with options	"depending on options to be used"	
Fan power supply	3-phase 400 Vac, 50Hz	
Capacity of fan power supply (kVA) 5)	22	
Maintenance		
Maintenance access	Front	
Cable entry 6)	Bottom in /Bottom out	
<p>1) Values valid for synchronous motor and asynchronous motor. The specifications for the maximum motor shaft power is based on a motor efficiency of 95%.</p> <p>2) Including the height of top cooling fans.</p> <p>3) For CE products: Typical cable size values based on use of copper cables in cable tray laying. Incoming cable size is based on drive current rating. It has to be checked to be in accordance to mains short circuit capability and local and national electrical code requirement as well all other applicable regulations.</p> <p>4) Variation in max. cable length may be possible depending on type cable and installation. For longer cable length between motor and drive contact Schneider Electric.</p> <p>5) Contact Schneider Electric if N+1 redundancy cooling fan requested.</p> <p>6) For other combination contact Schneider Electric.</p>		

ATV6000C588A6060

ATV6000	C588A6060NA●	
Nominal data	Normal Duty	Heavy Duty
Type rating [kVA]	5880	
Max. Motor power [kW] / [HP] 1)	4700/6302	3820/5122
Nominal Continuous output current [A] 1)	550	440
Max. output current with 120 %overload 1 min / 10 min [A]	660	/
Max. output current with 150 % overload 1 min / 10 min [A]	/	660
Power cells		
Number of cells per phase	5	
Power cell rated current [A]	550	
Power cell current with 120 %overload 1 min / 10 min [A]	660	
Max. output current for 3 sec [A]	825	
Characteristics with standard efficiency		
Efficiency at 100 % load (incl. Transformer) [%]	96.5%	
Total losses at 100 % load [kW]	178.0	144.7
Air flow [m ³ /h]	42000	
Noise level [dB (A)] @ 50 Hz	85	
Weight [kg / lb]	15689/34516	
Dimension [mm / inch] W*D*H 2)	7660*1800*3155/301.9*71*124.4	
Connection		
Incoming cable type	symmetrical three-phase	
Typical cable size (mm ² / AWG) 3)	95*2/2*000	
Motor cable type	symmetrical three-phase(Use of shielded cable is advisable)	
Typical cable size (mm ² / AWG) 3)	95*2/2*000	
Motor cable Max. length 4)	1000 m	
Grounding connection PE (mm ² / AWG)	95/000	
Control power supply	single phase, 230V, 50/60Hz,	
Capacity of control power supply w/o options	1 kVA	
Capacity of control power supply with options	"depending on options to be used"	
Fan power supply	3-phase 400 Vac, 50Hz	
Capacity of fan power supply (kVA) 5)	32	
Maintenance		
Maintenance access	Front	
Cable entry 6)	Bottom in /Bottom out	
1) Values valid for synchronous motor and asynchronous motor. The specifications for the maximum motor shaft power is based on a motor efficiency of 95%. 2) Including the height of top cooling fans. 3) For CE products: Typical cable size values based on use of copper cables in cable tray laying. Incoming cable size is based on drive current rating. It has to be checked to be in accordance to mains short circuit capability and local and national electrical code requirement as well all other applicable regulations. 4) Variation in max. cable length may be possible depending on type cable and installation. For longer cable length between motor and drive contact Schneider Electric. 5) Contact Schneider Electric if N+1 redundancy cooling fan requested. 6) For other combination contact Schneider Electric.		

ATV6000C638A6060...ATV6000C688A6060

ATV6000	C638A6060NA●		C688A6060NA●	
	Normal Duty	Heavy Duty	Normal Duty	Heavy Duty
Nominal data				
Type rating [kVA]	6380		6880	
Max. Motor power [kW] / [HP] 1)	5100/6839	4900/6571	5500/7375	5000/6705
Nominal Continuous output current [A] 1)	587	564	633	576
Max. output current with 120 %overload 1 min / 10 min [A]	704	/	760	/
Max. output current with 150 % overload 1 min / 10 min [A]	/	846	/	864
Power cells				
Number of cells per phase	5		5	
Power cell rated current [A]	720		720	
Power cell current with 120 %overload 1 min / 10 min [A]	864		864	
Max. output current for 3 sec [A]	1080		1080	
Characteristics with standard efficiency				
Efficiency at 100 % load (incl. Transformer) [%]	96.5%		96.5%	
Total losses at 100 % load [kW]	193.1	185.5	208.2	189.3
Air flow [m ³ /h]	50400		50400	
Noise level [dB (A)] @ 50 Hz	85		85	
Weight [kg / lb]	16423/36131		17042/37492	
Dimension [mm / inch] W*D*H 2)	7960*1800*3155/ 313.7*71*124.4		7960*1800*3155/ 313.7*71*124.4	
Connection				
Incoming cable type	symmetrical three-phase		symmetrical three-phase	
Typical cable size (mm ² / AWG) 3)	95*2/2*000		120*2/2*0000	
Motor cable type	symmetrical three-phase(Use of shielded cable is advisable)		symmetrical three-phase(Use of shielded cable is advisable)	
Typical cable size (mm ² / AWG) 3)	95*2/2*000		120*2/2*0000	
Motor cable Max. length 4)	1000 m		1000 m	
Grounding connection PE (mm ² / AWG)	120/0000		120/0000	
Control power supply	single phase, 230V, 50/60Hz,		single phase, 230V, 50/60Hz,	
Capacity of control power supply w/o options	1 kVA		1 kVA	
Capacity of control power supply with options	"depending on options to be used"		"depending on options to be used"	
Fan power supply	3-phase 400 Vac, 50Hz		3-phase 400 Vac, 50Hz	
Capacity of fan power supply (kVA) 5)	32		32	
Maintenance				
Maintenance access	Front & Rear		Front & Rear	
Cable entry 6)	Bottom in /Bottom out		Bottom in /Bottom out	
<p>1) Values valid for synchronous motor and asynchronous motor. The specifications for the maximum motor shaft power is based on a motor efficiency of 95%.</p> <p>2) Including the height of top cooling fans.</p> <p>3) For CE products: Typical cable size values based on use of copper cables in cable tray laying. Incoming cable size is based on drive current rating. It has to be checked to be in accordance to mains short circuit capability and local and national electrical code requirement as well all other applicable regulations.</p> <p>4) Variation in max. cable length may be possible depending on type cable and installation. For longer cable length between motor and drive contact Schneider Electric.</p> <p>5) Contact Schneider Electric if N+1 redundancy cooling fan requested.</p> <p>6) For other combination contact Schneider Electric.</p>				

ATV6000C782A6060...ATV6000M109A6060

ATV6000	C782A6060NA●		C863A6060NA●	
Nominal data	Normal Duty	Heavy Duty	Normal Duty	Heavy Duty
Type rating [kVA]	7820		8630	
Max. Motor power [kW] / [HP] 1)	6250/8381	5000/6705	6900/9253	5900/7912
Nominal Continuous output current [A] 1)	720	576	794	680
Max. output current with 120 %overload 1 min / 10 min [A]	864	/	953	/
Max. output current with 150 % overload 1 min / 10 min [A]	/	864	/	1020
Power cells				
Number of cells per phase	5		5	
Power cell rated current [A]	720		850	
Power cell current with 120 %overload 1 min / 10 min [A]	864		1020	
Max. output current for 3 sec [A]	1080		1275	
Characteristics with standard efficiency				
Efficiency at 100 % load (incl. Transformer) [%]	96.5%		96.5%	
Total losses at 100 % load [kW]	236.6	189.3	261.2	223.3
Air flow [m³/h]	58091		60131	
Noise level [dB (A)] @ 50 Hz	85		85	
Weight [kg / lb]	18341/40350		19447/42783	
Dimension [mm / inch] W*D*H 2)	8260*1800*3155/ 325.5*71*124.4		8260*1800*3155/ 325.5*71*124.4	
Connection				
Incoming cable type	symmetrical three-phase		symmetrical three-phase	
Typical cable size (mm² / AWG) 3)	150*2/2*300MCM		185*2/2*350MCM	
Motor cable type	symmetrical three-phase(Use of shielded cable is advisable)		symmetrical three-phase(Use of shielded cable is advisable)	
Typical cable size (mm² / AWG) 3)	150*2/2*300MCM		240*2/2*500MCM	
Motor cable Max. length 4)	1000 m		1000 m	
Grounding connection PE (mm² / AWG)	120/0000		150/300MCM	
Control power supply	single phase, 230V, 50/60Hz,		single phase, 230V, 50/60Hz,	
Capacity of control power supply w/o options	1 kVA		1 kVA	
Capacity of control power supply with options	"depending on options to be used"		"depending on options to be used"	
Fan power supply	3-phase 400 Vac, 50Hz		3-phase 400 Vac, 50Hz	
Capacity of fan power supply (kVA) 5)	37		44	
Maintenance				
Maintenance access	Front & Rear		Front & Rear	
Cable entry 6)	Bottom in /Bottom out		Bottom in /Bottom out	

ATV6000	C924A6060NA●		M100A6060NA●	
Nominal data	Normal Duty	Heavy Duty	Normal Duty	Heavy Duty
Type rating [kVA]	9240		10000	
Max. Motor power [kW] / [HP] 1)	7390/9910	5900/7912	8000/10728	6950/9320
Nominal Continuous output current [A] 1)	850	680	921	800
Max. output current with 120 %overload 1 min / 10 min [A]	1020	/	1105	/
Max. output current with 150 % overload1 min / 10 min [A]	/	1020	/	1200
Power cells				
Number of cells per phase	5		5	
Power cell rated current [A]	850		1000	
Power cell current with 120 %overload 1 min / 10 min [A]	1020		1200	
Max. output current for 3 sec [A]	1275		1500	
Characteristics with standard efficiency				
Efficiency at 100 % load (incl. Transformer) [%]	96.5%		96.5%	
Total losses at 100 % load [kW]	279.7	223.3	302.8	263.1
Air flow [m ³ /h]	60131		60131	
Noise level [dB (A)] @ 50 Hz	85		85	
Weight [kg / lb]	20202/44444		21249/46748	
Dimension [mm / inch] W*D*H 2)	8260*1800*3155/ 325.5*71*124.4		8260*1800*3155/ 325.5*71*124.4	
Connection				
Incoming cable type	symmetrical three-phase		symmetrical three-phase	
Typical cable size (mm ² / AWG) 3)	240*2/2*500MCM		240*2/2*500MCM	
Motor cable type	symmetrical three-phase(Use of shielded cable is advisable)		symmetrical three-phase(Use of shielded cable is advisable)	
Typical cable size (mm ² / AWG) 3)	240*2/2*500MCM		240*2/2*500MCM	
Motor cable Max. length 4)	1000 m		1000 m	
Grounding connection PE (mm ² / AWG)	150/300MCM		185/350MCM	
Control power supply	single phase, 230V, 50/60Hz,		single phase, 230V, 50/60Hz,	
Capacity of control power supply w/o options	1 kVA		1 kVA	
Capacity of control power supply with options	"depending on options to be used"		"depending on options to be used"	
Fan power supply	3-phase 400 Vac, 50Hz		3-phase 400 Vac, 50Hz	
Capacity of fan power supply (kVA) 5)	44		44	
Maintenance				
Maintenance access	Front & Rear		Front & Rear	
Cable entry 6)	Bottom in /Bottom out		Bottom in /Bottom out	

ATV6000	M109A6060NA●	
Nominal data	Normal Duty	Heavy Duty
Type rating [kVA]	10900	
Max. Motor power [kW] / [HP] 1)	8680/11640	6950/9320
Nominal Continuous output current [A] 1)	1000	800
Max. output current with 120 %overload 1 min / 10 min [A]	1200	/
Max. output current with 150 % overload 1 min / 10 min [A]	/	1200
Power cells		
Number of cells per phase	5	
Power cell rated current [A]	1000	
Power cell current with 120 %overload 1 min / 10 min [A]	1200	
Max. output current for 3 sec [A]	1500	
Characteristics with standard efficiency		
Efficiency at 100 % load (incl. Transformer) [%]	96.5%	
Total losses at 100 % load [kW]	328.6	263.1
Air flow [m ³ /h]	60131	
Noise level [dB (A)] @ 50 Hz	85	
Weight [kg / lb]	22363/49199	
Dimension [mm / inch] W*D*H 2)	8260*1800*3155/325.5*71*124.4	
Connection		
Incoming cable type	symmetrical three-phase	
Typical cable size (mm ² / AWG) 3)	150*3/3*300MCM	
Motor cable type	symmetrical three-phase(Use of shielded cable is advisable)	
Typical cable size (mm ² / AWG) 3)	240*2/2*500MCM	
Motor cable Max. length 4)	1000 m	
Grounding connection PE (mm ² / AWG)	185/350MCM	
Control power supply	single phase, 230V, 50/60Hz,	
Capacity of control power supply w/o options	1 kVA	
Capacity of control power supply with options	"depending on options to be used"	
Fan power supply	3-phase 400 Vac, 50Hz	
Capacity of fan power supply (kVA) 5)	44	
Maintenance		
Maintenance access	Front & Rear	
Cable entry 6)	Bottom in /Bottom out	
<p>1) Values valid for synchronous motor and asynchronous motor. The specifications for the maximum motor shaft power is based on a motor efficiency of 95%.</p> <p>2) Including the height of top cooling fans.</p> <p>3) For CE products: Typical cable size values based on use of copper cables in cable tray laying. Incoming cable size is based on drive current rating. It has to be checked to be in accordance to mains short circuit capability and local and national electrical code requirement as well all other applicable regulations.</p> <p>4) Variation in max. cable length may be possible depending on type cable and installation. For longer cable length between motor and drive contact Schneider Electric.</p> <p>5) Contact Schneider Electric if N+1 redundancy cooling fan requested.</p> <p>6) For other combination contact Schneider Electric.</p>		

Layout Drawing and Dimensions

Layout Drawing

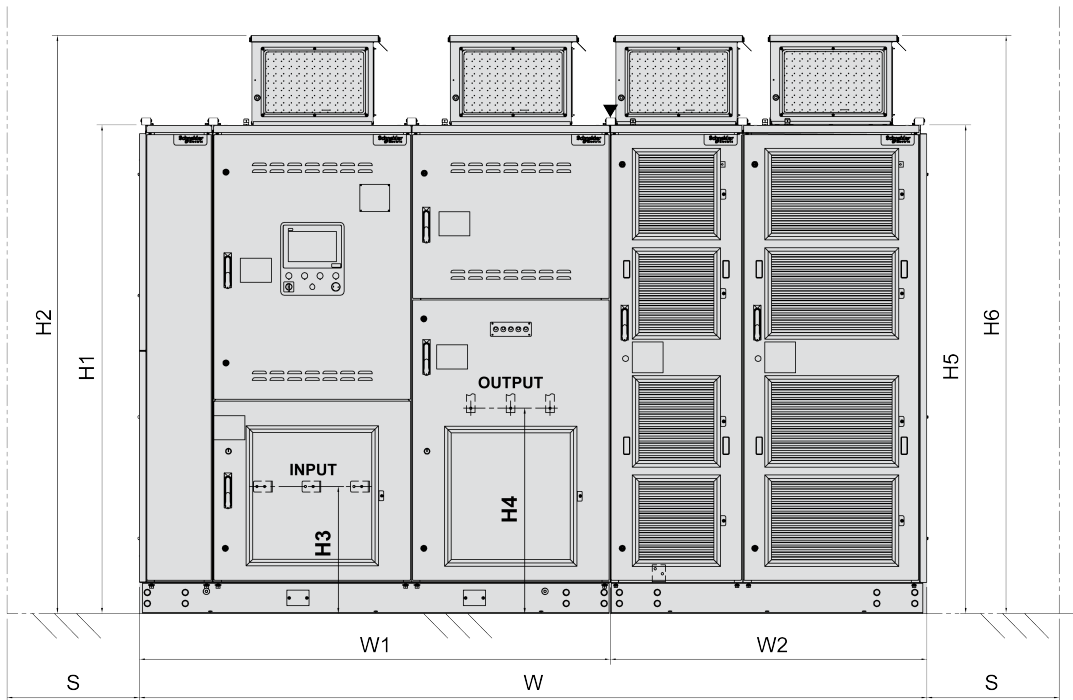

INPUT: Input terminal

OUTPUT: Output terminal

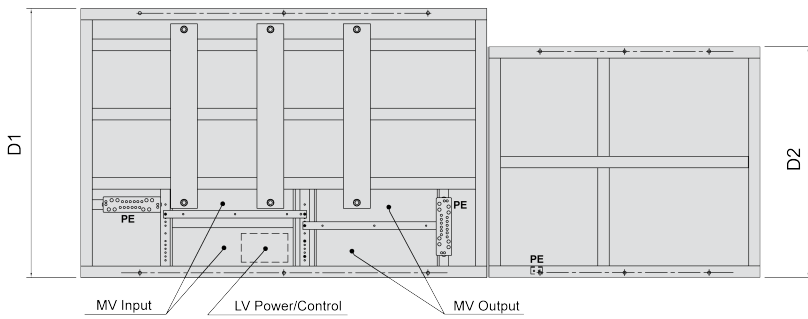

MV Input: MV Input cable area

LV Power/Control: LV Power/Control cable area

MV Output: MV Output cable area

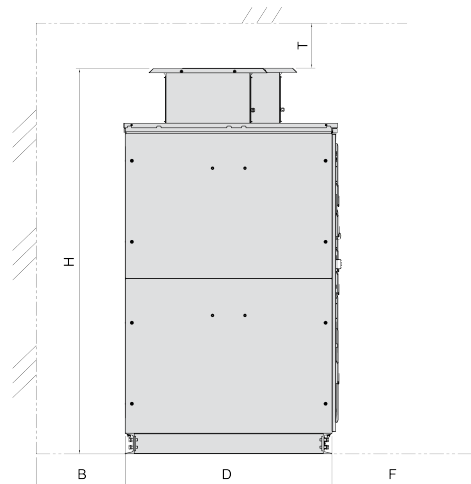

NOTE: Sketch is representing outline dimensions only, real cabinet arrangement is depending on power size.

Main dimensions - Output Voltage 6.0 kV

Product reference	Outer dimensions (mm / in)			Transformer cabinet			Powercell cabinet		
	W	H ^(b)	D	Fan Type	Fan Number	Weight [kg / lb]	Fan Type	Fan number	Weight [kg / lb]
ATV6000D450A6060...	2760	2618	1400	400	2	2291.4	500	1	844.7
	109	103	55			5041.1			1858.3
ATV6000D570A6060...	2760	2618	1400	400	2	2439.9	500	1	844.7
	109	103	55			5367.8			1858.3
ATV6000D700A6060...	2760	2618	1400	400	2	2600.9	500	1	844.7
	109	103	55			5722			1858.3
ATV6000D790A6060...	2760	2618	1400	400	2	2712.3	500	1	844.7
	109	103	55			5967.1			1858.3
ATV6000D890A6060...	2760	2618	1400	400	2	2836.1	500	1	844.7
	109	103	55			6239.4			1858.3
ATV6000C108A6060...	3060	2618	1400	450	2	3201.8	500	1	844.7
	120	103	55			7044			1858.3
ATV6000C125A6060...	3660	2618	1400	450	2	3412.3	500	2	1471
	144	103	55			7507.1			3236.2
ATV6000C138A6060...	3660	2618	1400	450	2	3573.2	500	2	1471
	144	103	55			7861			3236.2
ATV6000C163A6060...	3660	2754	1500	450	2	3938	500	2	1471
	144	108	59			8663.6			3236.2
ATV6000C188A6060...	4660	2754	1500	450	3	4370.3	400	3	2002
	183	108	59			9614.7			4404.4
ATV6000C213A6060...	4660	2754	1500	450	3	4679.9	400	3	2002
	183	108	59			10295.8			4404.4
ATV6000C239A6060...	4660	2754	1500	450	3	5001.8	400	3	2002
	183	108	59			11004			4404.4
ATV6000C263A6060...	4660	2754	1600	450	3	5339.4	500	3	2044.3
	183	108	63			11746.7			4497.5
ATV6000C304A6060...	4660	2754	1600	450	3	5847	500	3	2044.3
	183	108	63			12863.4			4497.5
ATV6000C348A6060...	5960	2754	1700	450	3	6453.3	400	5	3693.2
	235	108	67			14197.3			8125
ATV6000C375A6060...	5960	2754	1700	450	3	6787.6	400	5	3693.2
	235	108	67			14932.7			8125
ATV6000C413A6060...	5960	2754	1700	450	3	7258.1	400	5	3693.2
	235	108	67			15967.8			8125
ATV6000C445A6060...	5960	2754	1700	450	3	7654.3	400	5	3693.2
	235	108	67			16839.5			8125
ATV6000C532A6060...	5960	2795	1700	560	3	8846	450	5	3675.7
	235	110	67			19461.2			8086.5
ATV6000C588A6060...	7660	3155	1800	560	3	9949.2	500	5	5739.7
	302	124	71			21888.2			12627.3

Product reference	Outer dimensions (mm / in)			Transformer cabinet			Powercell cabinet		
	W	H ^(b)	D	Fan Type	Fan Number	Weight [kg / lb]	Fan Type	Fan number	Weight [kg / lb]
ATV6000C638A6060...	7960	3155	1800	560	3	10683	500	5	5739.7
	313	124	71			23502.6			12627.3
ATV6000C688A6060...	7960	3155	1800	560	3	11302	500	5	5739.7
	313	124	71			24864.4			12627.3
ATV6000C782A6060...	8260	3155	1800	560	4	12600.9	500	5	5739.7
	325	124	71			27722			12627.3
ATV6000C863A6060...	8260	3155	1800	560	4	13603.8	560	5	5842.7
	325	124	71			29928.4			12853.9
ATV6000C924A6060...	8260	3155	1800	560	4	14359	560	5	5842.7
	325	124	71			31589.8			12853.9
ATV6000M100A6060...	8260	3155	1800	560	4	15290.3	560	5	5957.7
	325	124	71			33638.7			13106.9
ATV6000M109A6060...	8260	3155	1800	560	4	16404.6	560	5	5957.7
	325	124	71			36090.1			13106.9

a) "H" is linked to higher size of transformer cabinet (H2) or transformer cabinet (H6).

Additional Dimensions - Output Voltage 6.0 kV

Product reference	Transformer Cabinet						Power cell Cabinet				Space Maintenance			
	(mm / in)						(mm / in)				(mm / in)			
	H1	H2	H3	H4	W1	D1	H5	H6	W2	D2	T	B (a)	F(b)	S(c)
ATV6000D450A6060***	2210	2540	500	780	1830	1400	2210	2618	930	1200	≥500	0	1500	0
	87	100	20	31	72	55	87	103	37	47	≥20		59	
ATV6000D570A6060***	2210	2540	500	780	1830	1400	2210	2618	930	1200	≥500	0	1500	0
	87	100	20	31	72	55	87	103	37	47	≥20		59	
ATV6000D700A6060***	2210	2540	500	780	1830	1400	2210	2618	930	1200	≥500	0	1500	0
	87	100	20	31	72	55	87	103	37	47	≥20		59	
ATV6000D790A6060***	2210	2540	500	780	1830	1400	2210	2618	930	1200	≥500	0	1500	0
	87	100	20	31	72	55	87	103	37	47	≥20		59	
ATV6000D890A6060***	2210	2540	500	780	1830	1400	2210	2618	930	1200	≥500	0	1500	0
	87	100	20	31	72	55	87	103	37	47	≥20		59	
ATV6000C108A6060***	2210	2604	500	780	2130	1400	2210	2618	930	1200	≥500	0	1500	0
	87	103	20	31	84	55	87	103	37	47	≥20		59	
ATV6000C125A6060***	2210	2604	500	780	2130	1400	2210	2618	1530	1200	≥500	0	1500	0
	87	103	20	31	84	55	87	103	60	47	≥20		59	
ATV6000C138A6060***	2210	2604	500	780	2130	1400	2210	2618	1530	1200	≥500	0	1500	0
	87	103	20	31	84	55	87	103	60	47	≥20		59	
ATV6000C163A6060***	2360	2754	500	930	2130	1500	2210	2618	1530	1200	≥500	0	1500	0
	93	108	20	37	84	59	87	103	60	47	≥20		59	
ATV6000C188A6060***	2360	2754	500	930	2430	1500	2210	2540	2230	1200	≥500	0	1500	0
	93	108	20	37	96	59	87	100	88	47	≥20		59	
ATV6000C213A6060***	2360	2754	500	930	2430	1500	2210	2540	2230	1200	≥500	0	1500	0
	93	108	20	37	96	59	87	100	88	47	≥20		59	
ATV6000C239A6060***	2360	2754	500	930	2430	1500	2210	2540	2230	1200	≥500	0	1500	0
	93	108	20	37	96	59	87	100	88	47	≥20		59	
ATV6000C263A6060***	2360	2754	500	930	2430	1600	2210	2618	2230	1200	≥500	0	1500	0
	93	108	20	37	96	63	87	103	88	47	≥20		59	
ATV6000C304A6060***	2360	2754	500	930	2430	1600	2210	2618	2230	1200	≥500	0	1500	0
	93	108	20	37	96	63	87	103	88	47	≥20		59	
ATV6000C348A6060***	2360	2754	500	930	2730	1700	2360	2690	3230	1200	≥500	0	1500	0
	93	108	20	37	107	67	93	106	127	47	≥20		59	
ATV6000C375A6060***	2360	2754	500	930	2730	1700	2360	2690	3230	1200	≥500	0	1500	0
	93	108	20	37	107	67	93	106	127	47	≥20		59	
ATV6000C413A6060***	2360	2754	500	930	2730	1700	2360	2690	3230	1200	≥500	0	1500	0
	93	108	20	37	107	67	93	106	127	47	≥20		59	
ATV6000C445A6060***	2360	2754	500	930	2730	1700	2360	2690	3230	1200	≥500	0	1500	0
	93	108	20	37	107	67	93	106	127	47	≥20		59	
ATV6000C532A6060***	2360	2795	500	930	2730	1700	2360	2754	3230	1200	≥500	0	1500	0
	93	110	20	37	107	67	93	108	127	47	≥20		59	
ATV6000C588A6060***	2720	3155	560	1290	3030	1800	2420	2828	4630	1400	≥500	0	1500	0
	107	124	22	51	119	71	95	111	182	55	≥20		59	

Product reference	Transformer Cabinet (mm / in)						Power cell Cabinet (mm / in)				Space Maintenance (mm / in)			
	H1	H2	H3	H4	W1	D1	H5	H6	W2	D2	T	B (a)	F(b)	S(c)
ATV6000C638A6060...	2720 107	3155 124	560 22	1290 51	3330 131	1800 71	2420 95	2828 111	4630 182	1400 55	≥500 ≥20	≥600 ≥24	1500 59	0
ATV6000C688A6060...	2720 107	3155 124	560 22	1290 51	3330 131	1800 71	2420 95	2828 111	4630 182	1400 55	≥500 ≥20	≥600 ≥24	1500 59	0
ATV6000C782A6060...	2720 107	3155 124	560 22	1290 51	3630 143	1800 71	2420 95	2828 111	4630 182	1400 55	≥500 ≥20	≥600 ≥24	1500 59	0
ATV6000C863A6060...	2720 107	3155 124	560 22	1290 51	3630 143	1800 71	2420 95	2855 112	4630 182	1400 55	≥500 ≥20	≥600 ≥24	1500 59	0
ATV6000C924A6060...	2720 107	3155 124	560 22	1290 51	3630 143	1800 71	2420 95	2855 112	4630 182	1400 55	≥500 ≥20	≥600 ≥24	1500 59	0
ATV6000M100A6060...	2720 107	3155 124	560 22	1290 51	3630 143	1800 71	2420 95	2855 112	4630 182	1600 63	≥500 ≥20	≥600 ≥24	1500 59	0
ATV6000M109A6060...	2720 107	3155 124	560 22	1290 51	3630 143	1800 71	2420 95	2855 112	4630 182	1600 63	≥500 ≥20	≥600 ≥24	1500 59	0

a) Space could be required for installation and lifting lugs.
b) For easy handling with power cell exchange tool 2000mm (78.7 in) are recommended.
c) Space (600mm) could be required for maintenance of the front & rear access drive.

Output Voltage 6.3 kV

ATV6000D450A6363...ATV6000D790A6363

ATV6000	D450A6363NA●		D570A6363NA●	
	Normal Duty	Heavy Duty	Normal Duty	Heavy Duty
Nominal data				
Type rating [kVA]	450		570	
Max. Motor power [kW] / [HP] 1)	355/476	330/442	450/603	420/563
Nominal Continuous output current [A] 1)	38.9	37	49.3	47
Max. output current with 120 %overload 1 min / 10 min [A]	46.6	/	59.1	/
Max. output current with 150 % overload 1 min / 10 min [A]	/	55.5	/	70.5
Power cells				
Number of cells per phase	5		5	
Power cell rated current [A]	65		65	
Power cell current with 120 %overload 1 min / 10 min [A]	78		78	
Max. output current for 3 sec [A]	97.5		97.5	
Characteristics with standard efficiency				
Efficiency at 100 % load (incl. Transformer) [%]	96.0%		96.0%	
Total losses at 100 % load [kW]	15.5	14.4	19.7	18.4
Air flow [m³/h]	9889		9889	
Noise level [dB (A)] @ 50 Hz	80		80	
Weight [kg / lb]	3137/6901		3285/7227	
Dimension [mm / inch] W*D*H 2)	2760*1400*2618/ 108.8*55.2*103.2		2760*1400*2618/ 108.8*55.2*103.2	
Connection				
Incoming cable type	symmetrical three-phase		symmetrical three-phase	
Typical cable size (mm² / AWG) 3)	95/000		95/000	
Motor cable type	symmetrical three-phase(Use of shielded cable is advisable)		symmetrical three-phase(Use of shielded cable is advisable)	
Typical cable size (mm² / AWG) 3)	25/4		25/4	
Motor cable Max. length 4)	1000 m		1000 m	
Grounding connection PE (mm² / AWG)	50/0		50/0	
Control power supply	single phase, 230V, 50/60Hz,		single phase, 230V, 50/60Hz,	
Capacity of control power supply w/o options	1 kVA		1 kVA	
Capacity of control power supply with options	"depending on options to be used"		"depending on options to be used"	
Fan power supply	3-phase 400 Vac, 50Hz		3-phase 400 Vac, 50Hz	
Capacity of fan power supply (kVA) 5)	6		6	
Maintenance				
Maintenance access	Front		Front	
Cable entry 6)	Bottom in /Bottom out		Bottom in /Bottom out	

ATV6000	D630A6363NA●		D740A6363NA●	
Nominal data	Normal Duty	Heavy Duty	Normal Duty	Heavy Duty
Type rating [kVA]	630		740	
Max. Motor power [kW] / [HP] 1)	500/670	470/630	590/791	470/630
Nominal Continuous output current [A] 1)	54.8	52	65	52
Max. output current with 120 %overload 1 min / 10 min [A]	65.7	/	78	/
Max. output current with 150 % overload1 min / 10 min [A]	/	78	/	78
Power cells				
Number of cells per phase	5		5	
Power cell rated current [A]	65		65	
Power cell current with 120 %overload 1 min / 10 min [A]	78		78	
Max. output current for 3 sec [A]	97.5		97.5	
Characteristics with standard efficiency				
Efficiency at 100 % load (incl. Transformer) [%]	96.0%		96.0%	
Total losses at 100 % load [kW]	21.9	20.5	25.7	20.5
Air flow [m ³ /h]	9889		9889	
Noise level [dB (A)] @ 50 Hz	80		80	
Weight [kg / lb]	3359/7390		3496/7691	
Dimension [mm / inch] W*D*H 2)	2760*1400*2618/ 108.8*55.2*103.2		2760*1400*2618/ 108.8*55.2*103.2	
Connection				
Incoming cable type	symmetrical three-phase		symmetrical three-phase	
Typical cable size (mm ² / AWG) 3)	95/000		95/000	
Motor cable type	symmetrical three-phase(Use of shielded cable is advisable)		symmetrical three-phase(Use of shielded cable is advisable)	
Typical cable size (mm ² / AWG) 3)	25/4		25/4	
Motor cable Max. length 4)	1000 m		1000 m	
Grounding connection PE (mm ² / AWG)	50/0		50/0	
Control power supply	single phase, 230V, 50/60Hz,		single phase, 230V, 50/60Hz,	
Capacity of control power supply w/o options	1 kVA		1 kVA	
Capacity of control power supply with options	"depending on options to be used"		"depending on options to be used"	
Fan power supply	3-phase 400 Vac, 50Hz		3-phase 400 Vac, 50Hz	
Capacity of fan power supply (kVA) 5)	6		6	
Maintenance				
Maintenance access	Front		Front	
Cable entry 6)	Bottom in /Bottom out		Bottom in /Bottom out	

ATV6000	D790A6363NA●	
Nominal data	Normal Duty	Heavy Duty
Type rating [kVA]	790	
Max. Motor power [kW] / [HP] 1)	630/844	600/804
Nominal Continuous output current [A] 1)	69.1	66
Max. output current with 120 %overload 1 min / 10 min [A]	82.9	/
Max. output current with 150 % overload 1 min / 10 min [A]	/	99
Power cells		
Number of cells per phase	5	
Power cell rated current [A]	100	
Power cell current with 120 %overload 1 min / 10 min [A]	120	
Max. output current for 3 sec [A]	150	
Characteristics with standard efficiency		
Efficiency at 100 % load (incl. Transformer) [%]	96.0%	
Total losses at 100 % load [kW]	27.4	26.2
Air flow [m³/h]	9889	
Noise level [dB (A)] @ 50 Hz	80	
Weight [kg / lb]	3558/7828	
Dimension [mm / inch] W*D*H 2)	2760*1400*2618/108.8*55.2*103.2	
Connection		
Incoming cable type	symmetrical three-phase	
Typical cable size (mm² / AWG) 3)	95/000	
Motor cable type	symmetrical three-phase(Use of shielded cable is advisable)	
Typical cable size (mm² / AWG) 3)	25/4	
Motor cable Max. length 4)	1000 m	
Grounding connection PE (mm² / AWG)	50/0	
Control power supply	single phase, 230V, 50/60Hz,	
Capacity of control power supply w/o options	1 kVA	
Capacity of control power supply with options	"depending on options to be used"	
Fan power supply	3-phase 400 Vac, 50Hz	
Capacity of fan power supply (kVA) 5)	6	
Maintenance		
Maintenance access	Front	
Cable entry 6)	Bottom in /Bottom out	
1) Values valid for synchronous motor and asynchronous motor. The specifications for the maximum motor shaft power is based on a motor efficiency of 95%. 2) Including the height of top cooling fans. 3) For CE products: Typical cable size values based on use of copper cables in cable tray laying. Incoming cable size is based on drive current rating. It has to be checked to be in accordance to mains short circuit capability and local and national electrical code requirement as well all other applicable regulations. 4) Variation in max. cable length may be possible depending on type cable and installation. For longer cable length between motor and drive contact Schneider Electric. 5) Contact Schneider Electric if N+1 redundancy cooling fan requested. 6) For other combination contact Schneider Electric.		

ATV6000D890A6363, ATV6000C114A6363

ATV6000	D890A6363NA●		C114A6363NA●	
Nominal data	Normal Duty	Heavy Duty	Normal Duty	Heavy Duty
Type rating [kVA]	890		1140	
Max. Motor power [kW] / [HP] 1)	710/952	670/898	910/1220	720/965
Nominal Continuous output current [A] 1)	77.8	74	100	80
Max. output current with 120 %overload 1 min / 10 min [A]	93.3	/	120	/
Max. output current with 150 % overload 1 min / 10 min [A]	/	111	/	120
Power cells				
Number of cells per phase	5		5	
Power cell rated current [A]	100		100	
Power cell current with 120 %overload 1 min / 10 min [A]	120		120	
Max. output current for 3 sec [A]	150		150	
Characteristics with standard efficiency				
Efficiency at 100 % load (incl. Transformer) [%]	96.0%		96.0%	
Total losses at 100 % load [kW]	30.9	29.2	39.6	31.4
Air flow [m ³ /h]	11940		11940	
Noise level [dB (A)] @ 50 Hz	80		83	
Weight [kg / lb]	3812/8386		4121/9066	
Dimension [mm / inch] W*D*H 2)	3060*1400*2618/ 120.6*55.2*103.2		3060*1400*2618/ 120.6*55.2*103.2	
Connection				
Incoming cable type	symmetrical three-phase		symmetrical three-phase	
Typical cable size (mm ² / AWG) 3)	95/000		95/000	
Motor cable type	symmetrical three-phase(Use of shielded cable is advisable)		symmetrical three-phase(Use of shielded cable is advisable)	
Typical cable size (mm ² / AWG) 3)	25/4		25/4	
Motor cable Max. length 4)	1000 m		1000 m	
Grounding connection PE (mm ² / AWG)	50/0		50/0	
Control power supply	single phase, 230V, 50/60Hz,		single phase, 230V, 50/60Hz,	
Capacity of control power supply w/o options	1 kVA		1 kVA	
Capacity of control power supply with options	"depending on options to be used"		"depending on options to be used"	
Fan power supply	3-phase 400 Vac, 50Hz		3-phase 400 Vac, 50Hz	
Capacity of fan power supply (kVA) 5)	7		7	
Maintenance				
Maintenance access	Front		Front	
Cable entry 6)	Bottom in /Bottom out		Bottom in /Bottom out	
<p>1) Values valid for synchronous motor and asynchronous motor. The specifications for the maximum motor shaft power is based on a motor efficiency of 95%.</p> <p>2) Including the height of top cooling fans.</p> <p>3) For CE products: Typical cable size values based on use of copper cables in cable tray laying. Incoming cable size is based on drive current rating. It has to be checked to be in accordance to mains short circuit capability and local and national electrical code requirement as well all other applicable regulations.</p> <p>4) Variation in max. cable length may be possible depending on type cable and installation. For longer cable length between motor and drive contact Schneider Electric.</p> <p>5) Contact Schneider Electric if N+1 redundancy cooling fan requested.</p> <p>6) For other combination contact Schneider Electric.</p>				

ATV6000C132A6363

ATV6000	C132A6363NA●	
Nominal data	Normal Duty	Heavy Duty
Type rating [kVA]	1320	
Max. Motor power [kW] / [HP] 1)	1050/1408	1000/1341
Nominal Continuous output current [A] 1)	115	110
Max. output current with 120 %overload 1 min / 10 min [A]	138	/
Max. output current with 150 % overload 1 min / 10 min [A]	/	165
Power cells		
Number of cells per phase	5	
Power cell rated current [A]	150	
Power cell current with 120 %overload 1 min / 10 min [A]	180	
Max. output current for 3 sec [A]	225	
Characteristics with standard efficiency		
Efficiency at 100 % load (incl. Transformer) [%]	96.0%	
Total losses at 100 % load [kW]	45.7	43.6
Air flow [m ³ /h]	17100	
Noise level [dB (A)] @ 50 Hz	83	
Weight [kg / lb]	4970/10934	
Dimension [mm / inch] W*D*H 2)	3660*1400*2618/144.3*55.2*103.2	
Connection		
Incoming cable type	symmetrical three-phase	
Typical cable size (mm ² / AWG) 3)	95/000	
Motor cable type	symmetrical three-phase(Use of shielded cable is advisable)	
Typical cable size (mm ² / AWG) 3)	35/2	
Motor cable Max. length 4)	1000 m	
Grounding connection PE (mm ² / AWG)	50/0	
Control power supply	single phase, 230V, 50/60Hz,	
Capacity of control power supply w/o options	1 kVA	
Capacity of control power supply with options	"depending on options to be used"	
Fan power supply	3-phase 400 Vac, 50Hz	
Capacity of fan power supply (kVA) 5)	10	
Maintenance		
Maintenance access	Front	
Cable entry 6)	Bottom in /Bottom out	
1) Values valid for synchronous motor and asynchronous motor. The specifications for the maximum motor shaft power is based on a motor efficiency of 95%. 2) Including the height of top cooling fans. 3) For CE products: Typical cable size values based on use of copper cables in cable tray laying. Incoming cable size is based on drive current rating. It has to be checked to be in accordance to mains short circuit capability and local and national electrical code requirement as well all other applicable regulations. 4) Variation in max. cable length may be possible depending on type cable and installation. For longer cable length between motor and drive contact Schneider Electric. 5) Contact Schneider Electric if N+1 redundancy cooling fan requested. 6) For other combination contact Schneider Electric.		

ATV6000C150A6363

ATV6000	C150A6363NA●	
Nominal data	Normal Duty	Heavy Duty
Type rating [kVA]	1500	
Max. Motor power [kW] / [HP] 1)	1200/1609	1090/1461
Nominal Continuous output current [A] 1)	132	120
Max. output current with 120 %overload 1 min / 10 min [A]	158	/
Max. output current with 150 % overload 1 min / 10 min [A]	/	180
Power cells		
Number of cells per phase	5	
Power cell rated current [A]	150	
Power cell current with 120 %overload 1 min / 10 min [A]	180	
Max. output current for 3 sec [A]	225	
Characteristics with standard efficiency		
Efficiency at 100 % load (incl. Transformer) [%]	96.0%	
Total losses at 100 % load [kW]	52.2	47.4
Air flow [m ³ /h]	17100	
Noise level [dB (A)] @ 50 Hz	83	
Weight [kg / lb]	5249/11548	
Dimension [mm / inch] W*D*H 2)	3660*1500*2754/144.3*59.1*108.6	
Connection		
Incoming cable type	symmetrical three-phase	
Typical cable size (mm ² / AWG) 3)	95/000	
Motor cable type	symmetrical three-phase(Use of shielded cable is advisable)	
Typical cable size (mm ² / AWG) 3)	35/2	
Motor cable Max. length 4)	1000 m	
Grounding connection PE (mm ² / AWG)	50/0	
Control power supply	single phase, 230V, 50/60Hz,	
Capacity of control power supply w/o options	1 kVA	
Capacity of control power supply with options	"depending on options to be used"	
Fan power supply	3-phase 400 Vac, 50Hz	
Capacity of fan power supply (kVA) 5)	10	
Maintenance		
Maintenance access	Front	
Cable entry 6)	Bottom in /Bottom out	
<p>1) Values valid for synchronous motor and asynchronous motor. The specifications for the maximum motor shaft power is based on a motor efficiency of 95%.</p> <p>2) Including the height of top cooling fans.</p> <p>3) For CE products: Typical cable size values based on use of copper cables in cable tray laying. Incoming cable size is based on drive current rating. It has to be checked to be in accordance to mains short circuit capability and local and national electrical code requirement as well all other applicable regulations.</p> <p>4) Variation in max. cable length may be possible depending on type cable and installation. For longer cable length between motor and drive contact Schneider Electric.</p> <p>5) Contact Schneider Electric if N+1 redundancy cooling fan requested.</p> <p>6) For other combination contact Schneider Electric.</p>		

ATV6000C170A6363

ATV6000	C170A6363NA●	
Nominal data	Normal Duty	Heavy Duty
Type rating [kVA]	1700	
Max. Motor power [kW] / [HP] 1)	1360/1823	1090/1461
Nominal Continuous output current [A] 1)	150	120
Max. output current with 120 %overload 1 min / 10 min [A]	180	/
Max. output current with 150 % overload 1 min / 10 min [A]	/	180
Power cells		
Number of cells per phase	5	
Power cell rated current [A]	150	
Power cell current with 120 %overload 1 min / 10 min [A]	180	
Max. output current for 3 sec [A]	225	
Characteristics with standard efficiency		
Efficiency at 100 % load (incl. Transformer) [%]	96.0%	
Total losses at 100 % load [kW]	59.2	47.4
Air flow [m³/h]	19920	
Noise level [dB (A)] @ 50 Hz	80	
Weight [kg / lb]	5619/12362	
Dimension [mm / inch] W*D*H 2)	3960*1500*2754/156.1*59.1*108.6	
Connection		
Incoming cable type	symmetrical three-phase	
Typical cable size (mm² / AWG) 3)	95/000	
Motor cable type	symmetrical three-phase(Use of shielded cable is advisable)	
Typical cable size (mm² / AWG) 3)	35/2	
Motor cable Max. length 4)	1000 m	
Grounding connection PE (mm² / AWG)	50/0	
Control power supply	single phase, 230V, 50/60Hz,	
Capacity of control power supply w/o options	1 kVA	
Capacity of control power supply with options	"depending on options to be used"	
Fan power supply	3-phase 400 Vac, 50Hz	
Capacity of fan power supply (kVA) 5)	11	
Maintenance		
Maintenance access	Front	
Cable entry 6)	Bottom in /Bottom out	
1) Values valid for synchronous motor and asynchronous motor. The specifications for the maximum motor shaft power is based on a motor efficiency of 95%. 2) Including the height of top cooling fans. 3) For CE products: Typical cable size values based on use of copper cables in cable tray laying. Incoming cable size is based on drive current rating. It has to be checked to be in accordance to mains short circuit capability and local and national electrical code requirement as well all other applicable regulations. 4) Variation in max. cable length may be possible depending on type cable and installation. For longer cable length between motor and drive contact Schneider Electric. 5) Contact Schneider Electric if N+1 redundancy cooling fan requested. 6) For other combination contact Schneider Electric.		

ATV6000C194A6363, ATV6000C228A6363

ATV6000	C194A6363NA●		C228A6363NA●	
Nominal data	Normal Duty	Heavy Duty	Normal Duty	Heavy Duty
Type rating [kVA]	1940		2280	
Max. Motor power [kW] / [HP] 1)	1550/2078	1450/1944	1820/2440	1450/1944
Nominal Continuous output current [A] 1)	170	160	200	160
Max. output current with 120 %overload 1 min / 10 min [A]	204	/	240	/
Max. output current with 150 % overload 1 min / 10 min [A]	/	240	/	240
Power cells				
Number of cells per phase	5		5	
Power cell rated current [A]	200		200	
Power cell current with 120 %overload 1 min / 10 min [A]	240		240	
Max. output current for 3 sec [A]	300		300	
Characteristics with standard efficiency				
Efficiency at 100 % load (incl. Transformer) [%]	96.0%		96.0%	
Total losses at 100 % load [kW]	67.4	63.1	79.1	63.1
Air flow [m ³ /h]	18912		18912	
Noise level [dB (A)] @ 50 Hz	80		80	
Weight [kg / lb]	6447/14183		6868/15110	
Dimension [mm / inch] W*D*H 2)	4660*1500*2754/ 183.7*59.1*108.6		4660*1500*2754/ 183.7*59.1*108.6	
Connection				
Incoming cable type	symmetrical three-phase		symmetrical three-phase	
Typical cable size (mm ² / AWG) 3)	95/000		95/000	
Motor cable type	symmetrical three-phase(Use of shielded cable is advisable)		symmetrical three-phase(Use of shielded cable is advisable)	
Typical cable size (mm ² / AWG) 3)	35/2		50/0	
Motor cable Max. length 4)	1000 m		1000 m	
Grounding connection PE (mm ² / AWG)	50/0		50/0	
Control power supply	single phase, 230V, 50/60Hz,		single phase, 230V, 50/60Hz,	
Capacity of control power supply w/o options	1 kVA		1 kVA	
Capacity of control power supply with options	"depending on options to be used"		"depending on options to be used"	
Fan power supply	3-phase 400 Vac, 50Hz		3-phase 400 Vac, 50Hz	
Capacity of fan power supply (kVA) 5)	8		8	
Maintenance				
Maintenance access	Front		Front	
Cable entry 6)	Bottom in /Bottom out		Bottom in /Bottom out	
<p>1) Values valid for synchronous motor and asynchronous motor. The specifications for the maximum motor shaft power is based on a motor efficiency of 95%.</p> <p>2) Including the height of top cooling fans.</p> <p>3) For CE products: Typical cable size values based on use of copper cables in cable tray laying. Incoming cable size is based on drive current rating. It has to be checked to be in accordance to mains short circuit capability and local and national electrical code requirement as well all other applicable regulations.</p> <p>4) Variation in max. cable length may be possible depending on type cable and installation. For longer cable length between motor and drive contact Schneider Electric.</p> <p>5) Contact Schneider Electric if N+1 redundancy cooling fan requested.</p> <p>6) For other combination contact Schneider Electric.</p>				

ATV6000C250A6363...ATV6000C282A6363

ATV6000	C250A6363NA●		C282A6363NA●	
Nominal data	Normal Duty	Heavy Duty	Normal Duty	Heavy Duty
Type rating [kVA]	2500		2820	
Max. Motor power [kW] / [HP] 1)	2000/2682	1600/2145	2250/3017	2040/2735
Nominal Continuous output current [A] 1)	220	176	247	224
Max. output current with 120 %overload 1 min / 10 min [A]	264	/	296	/
Max. output current with 150 % overload 1 min / 10 min [A]	/	264	/	336
Power cells				
Number of cells per phase	5		5	
Power cell rated current [A]	220		280	
Power cell current with 120 %overload 1 min / 10 min [A]	264		336	
Max. output current for 3 sec [A]	330		420	
Characteristics with standard efficiency				
Efficiency at 100 % load (incl. Transformer) [%]	96.0%		96.0%	
Total losses at 100 % load [kW]	87.0	69.6	97.8	88.7
Air flow [m³/h]	25440		25440	
Noise level [dB (A)] @ 50 Hz	83		83	
Weight [kg / lb]	7181/15798		7619/16762	
Dimension [mm / inch] W*D*H 2)	4660*1600*2754/ 183.7*63.1*108.6		4660*1600*2754/ 183.7*63.1*108.6	
Connection				
Incoming cable type	symmetrical three-phase		symmetrical three-phase	
Typical cable size (mm² / AWG) 3)	95/000		95/000	
Motor cable type	symmetrical three-phase(Use of shielded cable is advisable)		symmetrical three-phase(Use of shielded cable is advisable)	
Typical cable size (mm² / AWG) 3)	70/00		70/00	
Motor cable Max. length 4)	1000 m		1000 m	
Grounding connection PE (mm² / AWG)	50/0		50/0	
Control power supply	single phase, 230V, 50/60Hz,		single phase, 230V, 50/60Hz,	
Capacity of control power supply w/o options	1 kVA		1 kVA	
Capacity of control power supply with options	"depending on options to be used"		"depending on options to be used"	
Fan power supply	3-phase 400 Vac, 50Hz		3-phase 400 Vac, 50Hz	
Capacity of fan power supply (kVA) 5)	8		15	
Maintenance				
Maintenance access	Front		Front	
Cable entry 6)	Bottom in /Bottom out		Bottom in /Bottom out	
1) Values valid for synchronous motor and asynchronous motor. The specifications for the maximum motor shaft power is based on a motor efficiency of 95%. 2) Including the height of top cooling fans. 3) For CE products: Typical cable size values based on use of copper cables in cable tray laying. Incoming cable size is based on drive current rating. It has to be checked to be in accordance to mains short circuit capability and local and national electrical code requirement as well all other applicable regulations. 4) Variation in max. cable length may be possible depending on type cable and installation. For longer cable length between motor and drive contact Schneider Electric. 5) Contact Schneider Electric if N+1 redundancy cooling fan requested. 6) For other combination contact Schneider Electric.				

ATV6000C319A6363

ATV6000	C319A6363NA●	
Nominal data	Normal Duty	Heavy Duty
Type rating [kVA]	3190	
Max. Motor power [kW] / [HP] 1)	2550/3419	2040/2735
Nominal Continuous output current [A] 1)	280	224
Max. output current with 120 %overload 1 min / 10 min [A]	336	/
Max. output current with 150 % overload 1 min / 10 min [A]	/	336
Power cells		
Number of cells per phase	5	
Power cell rated current [A]	280	
Power cell current with 120 %overload 1 min / 10 min [A]	336	
Max. output current for 3 sec [A]	420	
Characteristics with standard efficiency		
Efficiency at 100 % load (incl. Transformer) [%]	96.0%	
Total losses at 100 % load [kW]	110.8	88.7
Air flow [m ³ /h]	26160	
Noise level [dB (A)] @ 50 Hz	80	
Weight [kg / lb]	8313/18289	
Dimension [mm / inch] W*D*H 2)	4960*1700*2754/195.5*67*108.6	
Connection		
Incoming cable type	symmetrical three-phase	
Typical cable size (mm ² / AWG) 3)	95/000	
Motor cable type	symmetrical three-phase(Use of shielded cable is advisable)	
Typical cable size (mm ² / AWG) 3)	95/000	
Motor cable Max. length 4)	1000 m	
Grounding connection PE (mm ² / AWG)	50/0	
Control power supply	single phase, 230V, 50/60Hz,	
Capacity of control power supply w/o options	1 kVA	
Capacity of control power supply with options	"depending on options to be used"	
Fan power supply	3-phase 400 Vac, 50Hz	
Capacity of fan power supply (kVA) 5)	15	
Maintenance		
Maintenance access	Front	
Cable entry 6)	Bottom in /Bottom out	
<p>1) Values valid for synchronous motor and asynchronous motor. The specifications for the maximum motor shaft power is based on a motor efficiency of 95%.</p> <p>2) Including the height of top cooling fans.</p> <p>3) For CE products: Typical cable size values based on use of copper cables in cable tray laying. Incoming cable size is based on drive current rating. It has to be checked to be in accordance to mains short circuit capability and local and national electrical code requirement as well all other applicable regulations.</p> <p>4) Variation in max. cable length may be possible depending on type cable and installation. For longer cable length between motor and drive contact Schneider Electric.</p> <p>5) Contact Schneider Electric if N+1 redundancy cooling fan requested.</p> <p>6) For other combination contact Schneider Electric.</p>		

ATV6000C364A6363

ATV6000	C364A6363NA●	
Nominal data	Normal Duty	Heavy Duty
Type rating [kVA]	3640	
Max. Motor power [kW] / [HP] 1)	2910/3902	2330/3124
Nominal Continuous output current [A] 1)	320	256
Max. output current with 120 %overload 1 min / 10 min [A]	384	/
Max. output current with 150 % overload 1 min / 10 min [A]	/	384
Power cells		
Number of cells per phase	5	
Power cell rated current [A]	320	
Power cell current with 120 %overload 1 min / 10 min [A]	384	
Max. output current for 3 sec [A]	480	
Characteristics with standard efficiency		
Efficiency at 100 % load (incl. Transformer) [%]	96.0%	
Total losses at 100 % load [kW]	126.5	101.3
Air flow [m³/h]	22464	
Noise level [dB (A)] @ 50 Hz	83	
Weight [kg / lb]	10345/22759	
Dimension [mm / inch] W*D*H 2)	5960*1700*2754/234.9*67*108.6	
Connection		
Incoming cable type	symmetrical three-phase	
Typical cable size (mm² / AWG) 3)	120/0000	
Motor cable type	symmetrical three-phase(Use of shielded cable is advisable)	
Typical cable size (mm² / AWG) 3)	120/0000	
Motor cable Max. length 4)	1000 m	
Grounding connection PE (mm² / AWG)	70/00	
Control power supply	single phase, 230V, 50/60Hz,	
Capacity of control power supply w/o options	1 kVA	
Capacity of control power supply with options	"depending on options to be used"	
Fan power supply	3-phase 400 Vac, 50Hz	
Capacity of fan power supply (kVA) 5)	10	
Maintenance		
Maintenance access	Front	
Cable entry 6)	Bottom in /Bottom out	
1) Values valid for synchronous motor and asynchronous motor. The specifications for the maximum motor shaft power is based on a motor efficiency of 95%. 2) Including the height of top cooling fans. 3) For CE products: Typical cable size values based on use of copper cables in cable tray laying. Incoming cable size is based on drive current rating. It has to be checked to be in accordance to mains short circuit capability and local and national electrical code requirement as well all other applicable regulations. 4) Variation in max. cable length may be possible depending on type cable and installation. For longer cable length between motor and drive contact Schneider Electric. 5) Contact Schneider Electric if N+1 redundancy cooling fan requested. 6) For other combination contact Schneider Electric.		

ATV6000C413A6363...ATV6000C513A6363

ATV6000	C413A6363NA●		C468A6363NA●	
Nominal data	Normal Duty	Heavy Duty	Normal Duty	Heavy Duty
Type rating [kVA]	4130		4680	
Max. Motor power [kW] / [HP] 1)	3300/4425	2990/4009	3740/5015	2990/4009
Nominal Continuous output current [A] 1)	362	328	410	328
Max. output current with 120 %overload 1 min / 10 min [A]	434	/	492	/
Max. output current with 150 % overload 1 min / 10 min [A]	/	492	/	492
Power cells				
Number of cells per phase	5		5	
Power cell rated current [A]	410		410	
Power cell current with 120 %overload 1 min / 10 min [A]	492		492	
Max. output current for 3 sec [A]	615		615	
Characteristics with standard efficiency				
Efficiency at 100 % load (incl. Transformer) [%]	96.0%		96.0%	
Total losses at 100 % load [kW]	143.4	130.0	162.5	130.0
Air flow [m ³ /h]	26184		26184	
Noise level [dB (A)] @ 50 Hz	83		83	
Weight [kg / lb]	11066/24345		11747/25843	
Dimension [mm / inch] W*D*H 2)	5960*1700*2795/ 234.9*67*110.2		5960*1700*2795/ 234.9*67*110.2	
Connection				
Incoming cable type	symmetrical three-phase		symmetrical three-phase	
Typical cable size (mm ² / AWG) 3)	150/300MCM		185/350MCM	
Motor cable type	symmetrical three-phase(Use of shielded cable is advisable)		symmetrical three-phase(Use of shielded cable is advisable)	
Typical cable size (mm ² / AWG) 3)	150/300MCM		185/350MCM	
Motor cable Max. length 4)	1000 m		1000 m	
Grounding connection PE (mm ² / AWG)	70/00		70/00	
Control power supply	single phase, 230V, 50/60Hz,		single phase, 230V, 50/60Hz,	
Capacity of control power supply w/o options	1 kVA		1 kVA	
Capacity of control power supply with options	"depending on options to be used"		"depending on options to be used"	
Fan power supply	3-phase 400 Vac, 50Hz		3-phase 400 Vac, 50Hz	
Capacity of fan power supply (kVA) 5)	20		20	
Maintenance				
Maintenance access	Front		Front	
Cable entry 6)	Bottom in /Bottom out		Bottom in /Bottom out	

ATV6000	C513A6363NA●	
Nominal data	Normal Duty	Heavy Duty
Type rating [kVA]	5130	
Max. Motor power [kW] / [HP] 1)	4100/5498	3570/4787
Nominal Continuous output current [A] 1)	449	392
Max. output current with 120 %overload 1 min / 10 min [A]	539	/
Max. output current with 150 % overload 1 min / 10 min [A]	/	588
Power cells		
Number of cells per phase	5	
Power cell rated current [A]	490	
Power cell current with 120 %overload 1 min / 10 min [A]	588	
Max. output current for 3 sec [A]	735	
Characteristics with standard efficiency		
Efficiency at 100 % load (incl. Transformer) [%]	96.5%	
Total losses at 100 % load [kW]	155.3	135.2
Air flow [m³/h]	29400	
Noise level [dB (A)] @ 50 Hz	83	
Weight [kg / lb]	12287/27031	
Dimension [mm / inch] W*D*H 2)	5960*1700*2795/234.9*67*110.2	
Connection		
Incoming cable type	symmetrical three-phase	
Typical cable size (mm² / AWG) 3)	240/500MCM	
Motor cable type	symmetrical three-phase(Use of shielded cable is advisable)	
Typical cable size (mm² / AWG) 3)	240/500MCM	
Motor cable Max. length 4)	1000 m	
Grounding connection PE (mm² / AWG)	95/000	
Control power supply	single phase, 230V, 50/60Hz,	
Capacity of control power supply w/o options	1 kVA	
Capacity of control power supply with options	"depending on options to be used"	
Fan power supply	3-phase 400 Vac, 50Hz	
Capacity of fan power supply (kVA) 5)	22	
Maintenance		
Maintenance access	Front	
Cable entry 6)	Bottom in /Bottom out	
1) Values valid for synchronous motor and asynchronous motor. The specifications for the maximum motor shaft power is based on a motor efficiency of 95%. 2) Including the height of top cooling fans. 3) For CE products: Typical cable size values based on use of copper cables in cable tray laying. Incoming cable size is based on drive current rating. It has to be checked to be in accordance to mains short circuit capability and local and national electrical code requirement as well all other applicable regulations. 4) Variation in max. cable length may be possible depending on type cable and installation. For longer cable length between motor and drive contact Schneider Electric. 5) Contact Schneider Electric if N+1 redundancy cooling fan requested. 6) For other combination contact Schneider Electric.		

ATV6000C558A6363

ATV6000	C558A6363NA●	
Nominal data	Normal Duty	Heavy Duty
Type rating [kVA]	5580	
Max. Motor power [kW] / [HP] 1)	4460/5980	3570/4787
Nominal Continuous output current [A] 1)	490	392
Max. output current with 120 %overload 1 min / 10 min [A]	588	/
Max. output current with 150 % overload 1 min / 10 min [A]	/	588
Power cells		
Number of cells per phase	5	
Power cell rated current [A]	490	
Power cell current with 120 %overload 1 min / 10 min [A]	588	
Max. output current for 3 sec [A]	735	
Characteristics with standard efficiency		
Efficiency at 100 % load (incl. Transformer) [%]	96.5%	
Total losses at 100 % load [kW]	168.8	135.2
Air flow [m ³ /h]	29400	
Noise level [dB (A)] @ 50 Hz	85	
Weight [kg / lb]	13264/29181	
Dimension [mm / inch] W*D*H 2)	6260*1800*3155/246.7*71*124.4	
Connection		
Incoming cable type	symmetrical three-phase	
Typical cable size (mm ² / AWG) 3)	95*2/2*00	
Motor cable type	symmetrical three-phase(Use of shielded cable is advisable)	
Typical cable size (mm ² / AWG) 3)	240/500MCM	
Motor cable Max. length 4)	1000 m	
Grounding connection PE (mm ² / AWG)	95/000	
Control power supply	single phase, 230V, 50/60Hz,	
Capacity of control power supply w/o options	1 kVA	
Capacity of control power supply with options	"depending on options to be used"	
Fan power supply	3-phase 400 Vac, 50Hz	
Capacity of fan power supply (kVA) 5)	22	
Maintenance		
Maintenance access	Front	
Cable entry 6)	Bottom in /Bottom out	
<p>1) Values valid for synchronous motor and asynchronous motor. The specifications for the maximum motor shaft power is based on a motor efficiency of 95%.</p> <p>2) Including the height of top cooling fans.</p> <p>3) For CE products: Typical cable size values based on use of copper cables in cable tray laying. Incoming cable size is based on drive current rating. It has to be checked to be in accordance to mains short circuit capability and local and national electrical code requirement as well all other applicable regulations.</p> <p>4) Variation in max. cable length may be possible depending on type cable and installation. For longer cable length between motor and drive contact Schneider Electric.</p> <p>5) Contact Schneider Electric if N+1 redundancy cooling fan requested.</p> <p>6) For other combination contact Schneider Electric.</p>		

ATV6000C627A6363...ATV6000C688A6363

ATV6000	C627A6363NA●		C688A6363NA●	
Nominal data	Normal Duty	Heavy Duty	Normal Duty	Heavy Duty
Type rating [kVA]	6270		6880	
Max. Motor power [kW] / [HP] 1)	5010/6718	4010/5377	5500/7375	5250/7040
Nominal Continuous output current [A] 1)	550	440	603	576
Max. output current with 120 %overload 1 min / 10 min [A]	660	/	723	/
Max. output current with 150 % overload 1 min / 10 min [A]	/	660	/	864
Power cells				
Number of cells per phase	5		5	
Power cell rated current [A]	550		720	
Power cell current with 120 %overload 1 min / 10 min [A]	660		864	
Max. output current for 3 sec [A]	825		1080	
Characteristics with standard efficiency				
Efficiency at 100 % load (incl. Transformer) [%]	96.5%		96.5%	
Total losses at 100 % load [kW]	189.7	151.8	208.2	198.7
Air flow [m³/h]	50400		50400	
Noise level [dB (A)] @ 50 Hz	85		85	
Weight [kg / lb]	16287/35831		17042/37492	
Dimension [mm / inch] W*D*H 2)	7960*1800*3155/ 313.7*71*124.4		7960*1800*3155/ 313.7*71*124.4	
Connection				
Incoming cable type	symmetrical three-phase		symmetrical three-phase	
Typical cable size (mm² / AWG) 3)	95*2/2*000		120*2/2*0000	
Motor cable type	symmetrical three-phase(Use of shielded cable is advisable)		symmetrical three-phase(Use of shielded cable is advisable)	
Typical cable size (mm² / AWG) 3)	95*2/2*000		95*2/2*000	
Motor cable Max. length 4)	1000 m		1000 m	
Grounding connection PE (mm² / AWG)	120/0000		120/0000	
Control power supply	single phase, 230V, 50/60Hz,		single phase, 230V, 50/60Hz,	
Capacity of control power supply w/o options	1 kVA		1 kVA	
Capacity of control power supply with options	"depending on options to be used"		"depending on options to be used"	
Fan power supply	3-phase 400 Vac, 50Hz		3-phase 400 Vac, 50Hz	
Capacity of fan power supply (kVA) 5)	32		32	
Maintenance				
Maintenance access	Front & Rear		Front & Rear	
Cable entry 6)	Bottom in /Bottom out		Bottom in /Bottom out	
1) Values valid for synchronous motor and asynchronous motor. The specifications for the maximum motor shaft power is based on a motor efficiency of 95%. 2) Including the height of top cooling fans. 3) For CE products: Typical cable size values based on use of copper cables in cable tray laying. Incoming cable size is based on drive current rating. It has to be checked to be in accordance to mains short circuit capability and local and national electrical code requirement as well all other applicable regulations. 4) Variation in max. cable length may be possible depending on type cable and installation. For longer cable length between motor and drive contact Schneider Electric. 5) Contact Schneider Electric if N+1 redundancy cooling fan requested. 6) For other combination contact Schneider Electric.				

ATV6000C750A6363...ATV6000M114A6363

ATV6000	C750A6363NA●		C820A6363NA●	
Nominal data	Normal Duty	Heavy Duty	Normal Duty	Heavy Duty
Type rating [kVA]	7500		8200	
Max. Motor power [kW] / [HP] 1)	6000/8046	5250/7040	6560/8797	5250/7040
Nominal Continuous output current [A] 1)	658	576	720	576
Max. output current with 120 %overload 1 min / 10 min [A]	789	/	864	/
Max. output current with 150 % overload 1 min / 10 min [A]	/	864	/	864
Power cells				
Number of cells per phase	5		5	
Power cell rated current [A]	720		720	
Power cell current with 120 %overload 1 min / 10 min [A]	864		864	
Max. output current for 3 sec [A]	1080		1080	
Characteristics with standard efficiency				
Efficiency at 100 % load (incl. Transformer) [%]	96.5%		96.5%	
Total losses at 100 % load [kW]	227.1	198.7	248.3	198.7
Air flow [m ³ /h]	58091		58091	
Noise level [dB (A)] @ 50 Hz	85		85	
Weight [kg / lb]	17945/39479		18812/41386	
Dimension [mm / inch] W*D*H 2)	8260*1800*3155/ 325.5*71*124.4		8260*1800*3155/ 325.5*71*124.4	
Connection				
Incoming cable type	symmetrical three-phase		symmetrical three-phase	
Typical cable size (mm ² / AWG) 3)	120*2/2*0000		150*2/2*300MCM	
Motor cable type	symmetrical three-phase(Use of shielded cable is advisable)		symmetrical three-phase(Use of shielded cable is advisable)	
Typical cable size (mm ² / AWG) 3)	120*2/2*0000		150*2/2*300MCM	
Motor cable Max. length 4)	1000 m		1000 m	
Grounding connection PE (mm ² / AWG)	120/0000		150/300MCM	
Control power supply	single phase, 230V, 50/60Hz,		single phase, 230V, 50/60Hz,	
Capacity of control power supply w/o options	1 kVA		1 kVA	
Capacity of control power supply with options	"depending on options to be used"		"depending on options to be used"	
Fan power supply	3-phase 400 Vac, 50Hz		3-phase 400 Vac, 50Hz	
Capacity of fan power supply (kVA) 5)	37		37	
Maintenance				
Maintenance access	Front & Rear		Front & Rear	
Cable entry 6)	Bottom in /Bottom out		Bottom in /Bottom out	

ATV6000	C888A6363NA●		C969A6363NA●	
Nominal data	Normal Duty	Heavy Duty	Normal Duty	Heavy Duty
Type rating [kVA]	8880		9690	
Max. Motor power [kW] / [HP] 1)	7100/9521	6200/8314	7750/10392	6200/8314
Nominal Continuous output current [A] 1)	778	680	850	680
Max. output current with 120 %overload 1 min / 10 min [A]	934	/	1020	/
Max. output current with 150 % overload 1 min / 10 min [A]	/	1020	/	1020
Power cells				
Number of cells per phase	5		5	
Power cell rated current [A]	850		850	
Power cell current with 120 %overload 1 min / 10 min [A]	1020		1020	
Max. output current for 3 sec [A]	1275		1275	
Characteristics with standard efficiency				
Efficiency at 100 % load (incl. Transformer) [%]	96.5%		96.5%	
Total losses at 100 % load [kW]	268.8	234.7	293.4	234.7
Air flow [m³/h]	60131		60131	
Noise level [dB (A)] @ 50 Hz	85		85	
Weight [kg / lb]	19756/43463		20759/45670	
Dimension [mm / inch] W*D*H 2)	8260*1800*3155/ 325.5*71*124.4		8260*1800*3155/ 325.5*71*124.4	
Connection				
Incoming cable type	symmetrical three-phase		symmetrical three-phase	
Typical cable size (mm² / AWG) 3)	185*2/2*350MCM		240*2/2*500MCM	
Motor cable type	symmetrical three-phase(Use of shielded cable is advisable)		symmetrical three-phase(Use of shielded cable is advisable)	
Typical cable size (mm² / AWG) 3)	240*2/2*500MCM		240*2/2*500MCM	
Motor cable Max. length 4)	1000 m		1000 m	
Grounding connection PE (mm² / AWG)	150/300MCM		185/350MCM	
Control power supply	single phase, 230V, 50/60Hz,		single phase, 230V, 50/60Hz,	
Capacity of control power supply w/o options	1 kVA		1 kVA	
Capacity of control power supply with options	"depending on options to be used"		"depending on options to be used"	
Fan power supply	3-phase 400 Vac, 50Hz		3-phase 400 Vac, 50Hz	
Capacity of fan power supply (kVA) 5)	44		44	
Maintenance				
Maintenance access	Front & Rear		Front & Rear	
Cable entry 6)	Bottom in /Bottom out		Bottom in /Bottom out	

ATV6000	M105A6363NA●		M114A6363NA●	
Nominal data	Normal Duty	Heavy Duty	Normal Duty	Heavy Duty
Type rating [kVA]	10500		11400	
Max. Motor power [kW] / [HP] 1)	8400/11264	7290/9776	9120/12230	7290/9776
Nominal Continuous output current [A] 1)	921	800	1000	800
Max. output current with 120 % overload 1 min / 10 min [A]	1105	/	1200	/
Max. output current with 150 % overload 1 min / 10 min [A]	/	1200	/	1200
Power cells				
Number of cells per phase	5		5	
Power cell rated current [A]	1000		1000	
Power cell current with 120 % overload 1 min / 10 min [A]	1200		1200	
Max. output current for 3 sec [A]	1500		1500	
Characteristics with standard efficiency				
Efficiency at 100 % load (incl. Transformer) [%]	96.5%		96.5%	
Total losses at 100 % load [kW]	317.9	275.9	345.2	275.9
Air flow [m ³ /h]	60131		60131	
Noise level [dB (A)] @ 50 Hz	85		85	
Weight [kg / lb]	21868/48110		22982/50560	
Dimension [mm / inch] W*D*H 2)	8260*1800*3155/ 325.5*71*124.4		8260*1800*3155/ 325.5*71*124.4	
Connection				
Incoming cable type	symmetrical three-phase		symmetrical three-phase	
Typical cable size (mm ² / AWG) 3)	240*2/2*500MCM		120*3/3*0000	
Motor cable type	symmetrical three-phase(Use of shielded cable is advisable)		symmetrical three-phase(Use of shielded cable is advisable)	
Typical cable size (mm ² / AWG) 3)	240*2/2*500MCM		240*2/2*500MCM	
Motor cable Max. length 4)	1000 m		1000 m	
Grounding connection PE (mm ² / AWG)	185/350MCM		185/350MCM	
Control power supply	single phase, 230V, 50/60Hz,		single phase, 230V, 50/60Hz,	
Capacity of control power supply w/o options	1 kVA		1 kVA	
Capacity of control power supply with options	"depending on options to be used"		"depending on options to be used"	
Fan power supply	3-phase 400 Vac, 50Hz		3-phase 400 Vac, 50Hz	
Capacity of fan power supply (kVA) 5)	44		44	
Maintenance				
Maintenance access	Front & Rear		Front & Rear	
Cable entry 6)	Bottom in /Bottom out		Bottom in /Bottom out	
<p>1) Values valid for synchronous motor and asynchronous motor. The specifications for the maximum motor shaft power is based on a motor efficiency of 95%.</p> <p>2) Including the height of top cooling fans.</p> <p>3) For CE products: Typical cable size values based on use of copper cables in cable tray laying. Incoming cable size is based on drive current rating. It has to be checked to be in accordance to mains short circuit capability and local and national electrical code requirement as well all other applicable regulations.</p> <p>4) Variation in max. cable length may be possible depending on type cable and installation. For longer cable length between motor and drive contact Schneider Electric.</p> <p>5) Contact Schneider Electric if N+1 redundancy cooling fan requested.</p> <p>6) For other combination contact Schneider Electric.</p>				

Layout Drawing and Dimensions

Layout Drawing

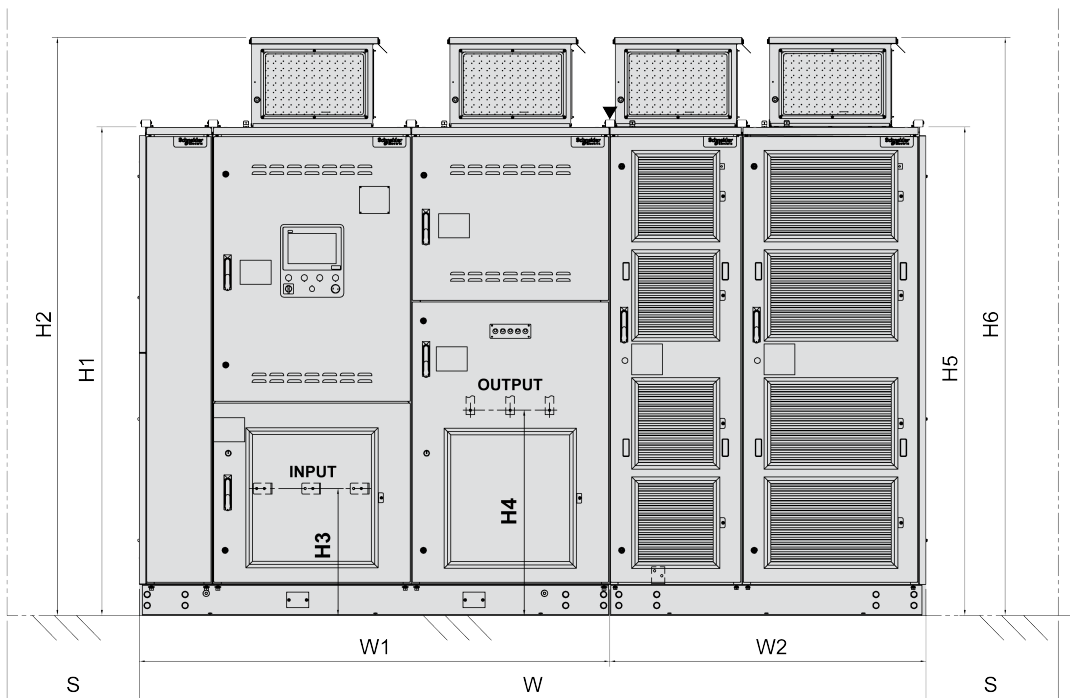

INPUT: Input terminal

OUTPUT: Output terminal

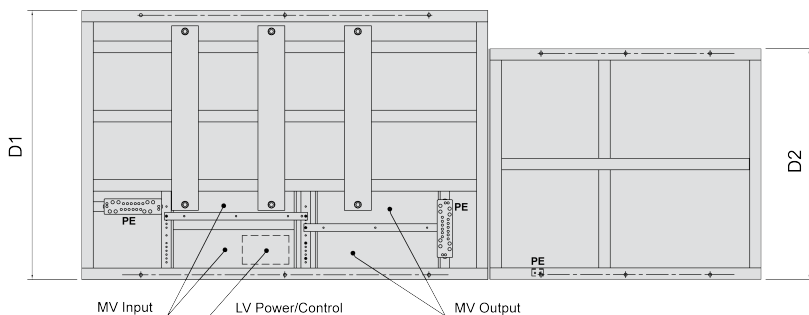

MV Input: MV Input cable area

LV Power/Control: LV Power/Control cable area

MV Output: MV Output cable area

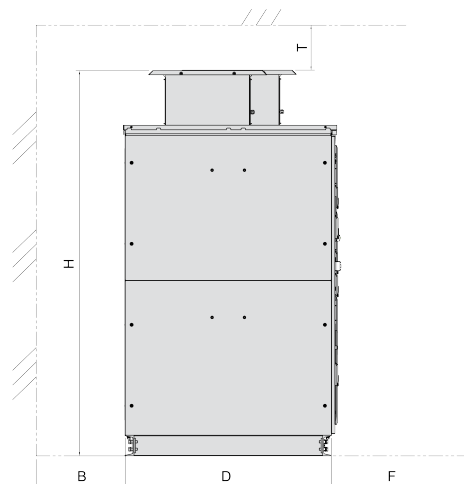

NOTE: Sketch is representing outline dimensions only, real cabinet arrangement is depending on power size.

Main dimensions - Output Voltage 6.3 kV

Product reference	Outer dimensions (mm / in)			Transformer cabinet			Powercell cabinet		
	W	H ^(b)	D	Fan Type	Fan Number	Weight [kg / lb]	Fan Type	Fan number	Weight [kg / lb]
ATV6000D450A6363...	2760	2618	1400	400	2	2291.4	500	1	844.7
	109	103	55			5041.1			1858.3
ATV6000D570A6363...	2760	2618	1400	400	2	2439.9	500	1	844.7
	109	103	55			5367.8			1858.3
ATV6000D630A6363...	2760	2618	1400	400	2	2514.2	500	1	844.7
	109	103	55			5531.2			1858.3
ATV6000D740A6363...	2760	2618	1400	400	2	2650.4	500	1	844.7
	109	103	55			5830.9			1858.3
ATV6000D790A6363...	2760	2618	1400	400	2	2712.3	500	1	844.7
	109	103	55			5967.1			1858.3
ATV6000D890A6363...	3060	2618	1400	450	2	2966.6	500	1	844.7
	120	103	55			6526.5			1858.3
ATV6000C114A6363...	3060	2618	1400	450	2	3276.1	500	1	844.7
	120	103	55			7207.4			1858.3
ATV6000C132A6363...	3660	2618	1400	450	2	3499	500	2	1471
	144	103	55			7697.8			3236.2
ATV6000C150A6363...	3660	2754	1500	450	2	3777	500	2	1471
	144	108	59			8309.4			3236.2
ATV6000C170A6363...	3960	2754	1500	450	3	4147.5	500	2	1471
	156	108	59			9124.5			3236.2
ATV6000C194A6363...	4660	2754	1500	450	3	4444.6	400	3	2002
	183	108	59			9778.1			4404.4
ATV6000C225A6363...	4660	2754	1500	450	3	4865.6	400	3	2002
	183	108	59			10704.3			4404.4
ATV6000C250A6363...	4660	2754	1600	450	3	5178.4	400	3	2002
	183	108	63			11392.5			4404.4
ATV6000C282A6363...	4660	2754	1600	450	3	5574.6	500	3	2044.3
	183	108	63			12264.1			4497.5
ATV6000C319A6363...	4960	2754	1700	450	3	6096.9	500	3	2216
	195	108	67			13413.2			4875.2
ATV6000C364A6363...	5960	2754	1700	450	3	6651.4	400	5	3693.2
	235	108	67			14633.1			8125
ATV6000C413A6363...	5960	2795	1700	560	3	7372.7	400	5	3693.2
	235	110	67			16219.9			8125
ATV6000C468A6363...	5960	2795	1700	560	3	8053.6	400	5	3693.2
	235	110	67			17717.9			8125
ATV6000C513A6363...	5960	2795	1700	560	3	8610.8	450	5	3675.7
	235	110	67			18943.8			8086.5
ATV6000C558A6363...	6260	3155	1800	560	3	9587.4	450	5	3675.7
	246	124	71			21092.3			8086.5

Product reference	Outer dimensions (mm / in)			Transformer cabinet			Powercell cabinet		
	W	H ^(b)	D	Fan Type	Fan Number	Weight [kg / lb]	Fan Type	Fan number	Weight [kg / lb]
ATV6000C627A6363...	7960	3155	1800	560	3	10546.8	500	5	5739.7
	313	124	71			23203			12627.3
ATV6000C688A6363...	7960	3155	1800	560	3	11302	500	5	5739.7
	313	124	71			24864.4			12627.3
ATV6000C750A6363...	8260	3155	1800	560	4	12204.8	500	5	5739.7
	325	124	71			26850.6			12627.3
ATV6000C820A6363...	8260	3155	1800	560	4	13071.4	500	5	5739.7
	325	124	71			28757.1			12627.3
ATV6000C888A6363...	8260	3155	1800	560	4	13913.3	560	5	5842.7
	325	124	71			30609.3			12853.9
ATV6000C970A6363...	8260	3155	1800	560	4	14916.1	560	5	5842.7
	325	124	71			32815.4			12853.9
ATV6000M105A6363...	8260	3155	1800	560	4	15909.4	560	5	5957.7
	325	124	71			35000.7			13106.9
ATV6000M114A6363...	8260	3155	1800	560	4	17023.6	560	5	5957.7
	325	124	71			37451.9			13106.9

a) "H" is linked to higher size of transformer cabinet (H2) or transformer cabinet (H6).

Additional Dimensions - Output Voltage 6.3 kV

Product reference	Transformer Cabinet						Power cell Cabinet				Space Maintenance			
	(mm / in)						(mm / in)				(mm / in)			
	H1	H2	H3	H4	W1	D1	H5	H6	W2	D2	T	B (a)	F (b)	S(c)
ATV6000D450A6363...	2210 87	2540 100	500 20	780 31	1830 72	1400 55	2210 87	2618 103	930 37	1200 47	≥500 ≥20	0	1500 59	0
ATV6000D570A6363...	2210 87	2540 100	500 20	780 31	1830 72	1400 55	2210 87	2618 103	930 37	1200 47	≥500 ≥20	0	1500 59	0
ATV6000D630A6363...	2210 87	2540 100	500 20	780 31	1830 72	1400 55	2210 87	2618 103	930 37	1200 47	≥500 ≥20	0	1500 59	0
ATV6000D740A6363...	2210 87	2540 100	500 20	780 31	1830 72	1400 55	2210 87	2618 103	930 37	1200 47	≥500 ≥20	0	1500 59	0
ATV6000D790A6363...	2210 87	2540 100	500 20	780 31	1830 72	1400 55	2210 87	2618 103	930 37	1200 47	≥500 ≥20	0	1500 59	0
ATV6000D890A6363...	2210 87	2604 103	500 22	780 31	2130 84	1400 55	2210 87	2618 103	930 37	1200 47	≥500 ≥20	0	1500 59	0
ATV6000C114A6363...	2210 87	2604 103	500 20	780 31	2130 84	1400 55	2210 87	2618 103	930 37	1200 47	≥500 ≥20	0	1500 59	0
ATV6000C132A6363...	2210 87	2604 103	500 20	780 31	2130 84	1400 55	2210 87	2618 103	1530 60	1200 47	≥500 ≥20	0	1500 59	0
ATV6000C150A6363...	2360 93	2754 108	500 20	930 37	2130 84	1500 59	2210 87	2618 103	1530 60	1200 47	≥500 ≥20	0	1500 59	0
ATV6000C170A6363...	2360 93	2754 108	500 20	930 37	2430 96	1500 59	2210 87	2618 103	1530 60	1200 47	≥500 ≥20	0	1500 59	0
ATV6000C194A6363...	2360 93	2754 108	500 20	930 37	2430 96	1500 59	2210 87	2540 100	2230 88	1200 47	≥500 ≥20	0	1500 59	0
ATV6000C225A6363...	2360 93	2754 108	500 20	930 37	2430 96	1500 59	2210 87	2540 100	2230 88	1200 47	≥500 ≥20	0	1500 59	0
ATV6000C250A6363...	2360 93	2754 108	500 20	930 37	2430 96	1600 63	2210 87	2540 100	2230 88	1200 47	≥500 ≥20	0	1500 59	0
ATV6000C282A6363...	2360 93	2754 108	500 20	930 37	2430 96	1600 63	2210 87	2618 103	2230 88	1200 47	≥500 ≥20	0	1500 59	0
ATV6000C319A6363...	2360 93	2754 108	500 20	930 37	2730 107	1700 67	2210 87	2618 103	2230 88	1200 47	≥500 ≥20	0	1500 59	0
ATV6000C364A6363...	2360 93	2754 108	500 20	930 37	2730 107	1700 67	2360 93	2690 106	3230 127	1200 47	≥500 ≥20	0	1500 59	0
ATV6000C413A6363...	2360 93	2795 110	500 20	930 37	2730 107	1700 67	2360 93	2690 106	3230 127	1200 47	≥500 ≥20	0	1500 59	0
ATV6000C468A6363...	2360 93	2795 110	500 20	930 37	2730 107	1700 67	2360 93	2690 106	3230 127	1200 47	≥500 ≥20	0	1500 59	0
ATV6000C513A6363...	2360 93	2795 110	500 20	930 37	2730 107	1700 67	2360 93	2754 108	3230 127	1200 47	≥500 ≥20	0	1500 59	0
ATV6000C558A6363...	2720 107	3155 124	560 22	1290 51	3030 119	1800 71	2420 95	2814 111	3230 127	1200 47	≥500 ≥20	0	1500 59	0

Product reference	Transformer Cabinet (mm / in)						Power cell Cabinet (mm / in)				Space Maintenance (mm / in)			
	H1	H2	H3	H4	W1	D1	H5	H6	W2	D2	T	B (a)	F (b)	S(c)
ATV6000C627A6363***	2720	3155	560	1290	3330	1800	2420	2828	4630	1400	≥500	0	1500	0
	107	124	22	51	131	71	95	111	182	55	≥20		59	
ATV6000C688A6363***	2720	3155	560	1290	3330	1800	2420	2828	4630	1400	≥500	0	1500	0
	107	124	22	51	131	71	95	111	182	55	≥20		59	
ATV6000C750A6363***	2720	3155	560	1290	3630	1800	2420	2828	4630	1400	≥500	0	1500	0
	107	124	22	51	143	71	95	111	182	55	≥20		59	
ATV6000C820A6363***	2720	3155	560	1290	3630	1800	2420	2828	4630	1400	≥500	0	1500	0
	107	124	22	51	143	71	95	111	182	55	≥20		59	
ATV6000C888A6363***	2720	3155	560	1290	3630	1800	2420	2855	4630	1400	≥500	0	1500	0
	107	124	22	51	143	71	95	112	182	55	≥20		59	
ATV6000C970A6363***	2720	3155	560	1290	3630	1800	2420	2855	4630	1400	≥500	0	1500	0
	107	124	22	51	143	71	95	112	182	55	≥20		59	
ATV6000M105A6363***	2720	3155	560	1290	3630	1800	2420	2855	4630	1600	≥500	≥600	1500	0
	107	124	22	51	143	71	95	112	182	63	≥20	≥24	59	
ATV6000M114A6363***	2720	3155	560	1290	3630	1800	2420	2855	4630	1600	≥500	≥600	1500	0
	107	124	22	51	143	71	95	112	182	63	≥20	≥24	59	

a) Space could be required for installation and lifting lugs.
 b) For easy handling with power cell exchange tool 2000mm (78.7 in) are recommended.
 c) Space (600mm) could be required for maintenance of the front & rear access drive.

Output Voltage 6.6 kV

ATV6000D450A6666...ATV6000D890A6666

ATV6000	D450A6666NA●		D570A6666NA●	
	Normal Duty	Heavy Duty	Normal Duty	Heavy Duty
Nominal data				
Type rating [kVA]	450		570	
Max. Motor power [kW] / [HP] 1)	355/476	330/442	450/603	430/576
Nominal Continuous output current [A] 1)	37.1	35	47.1	45
Max. output current with 120 %overload 1 min / 10 min [A]	44.5	/	56.5	/
Max. output current with 150 % overload 1 min / 10 min [A]	/	52.5	/	67.5
Power cells				
Number of cells per phase	5		5	
Power cell rated current [A]	65		65	
Power cell current with 120 %overload 1 min / 10 min [A]	78		78	
Max. output current for 3 sec [A]	97.5		97.5	
Characteristics with standard efficiency				
Efficiency at 100 % load (incl. Transformer) [%]	96.0%		96.0%	
Total losses at 100 % load [kW]	15.5	14.4	19.7	18.7
Air flow [m ³ /h]	9889		9889	
Noise level [dB (A)] @ 50 Hz	80		80	
Weight [kg / lb]	3137/6901		3285/7227	
Dimension [mm / inch] W*D*H 2)	2760*1400*2618/ 108.8*55.2*103.2		2760*1400*2618/ 108.8*55.2*103.2	
Connection				
Incoming cable type	symmetrical three-phase		symmetrical three-phase	
Typical cable size (mm ² / AWG) 3)	95/000		95/000	
Motor cable type	symmetrical three-phase(Use of shielded cable is advisable)		symmetrical three-phase(Use of shielded cable is advisable)	
Typical cable size (mm ² / AWG) 3)	25/4		25/4	
Motor cable Max. length 4)	3280 ft (1000 m)		3280 ft (1000 m)	
Grounding connection PE (mm ² / AWG)	50/0		50/0	
Control power supply	single phase, 230V, 50/60Hz		single phase, 230V, 50/60Hz	
Capacity of control power supply w/o options	1 kVA		1 kVA	
Capacity of control power supply with options	"depending on options to be used"		"depending on options to be used"	
Fan power supply	3-phase 400 Vac, 50Hz		3-phase 400 Vac, 50Hz	
Capacity of fan power supply (kVA) 5)	6		6	
Maintenance				
Maintenance access	Front		Front	
Cable entry 6)	Bottom in /Bottom out		Bottom in /Bottom out	

ATV6000	D630A6666NA●		D780A6666NA●	
	Normal Duty	Heavy Duty	Normal Duty	Heavy Duty
Nominal data				
Type rating [kVA]	630		780	
Max. Motor power [kW] / [HP] 1)	500/670	470/630	620/831	590/791
Nominal Continuous output current [A] 1)	52.3	50	65	62
Max. output current with 120 %overload 1 min / 10 min [A]	62.7	/	78	/
Max. output current with 150 % overload 1 min / 10 min [A]	/	75	/	93
Power cells				
Number of cells per phase	5		5	
Power cell rated current [A]	65		100	
Power cell current with 120 %overload 1 min / 10 min [A]	78		120	
Max. output current for 3 sec [A]	97.5		150	
Characteristics with standard efficiency				
Efficiency at 100 % load (incl. Transformer) [%]	96.0%		96.0%	
Total losses at 100 % load [kW]	21.9	20.5	27.0	25.7
Air flow [m³/h]	9889		9889	
Noise level [dB (A)] @ 50 Hz	80		80	
Weight [kg / lb]	3359/7390		3545/7799	
Dimension [mm / inch] W*D*H 2)	2760*1400*2618/ 108.8*55.2*103.2		2760*1400*2618/ 108.8*55.2*103.2	
Connection				
Incoming cable type	symmetrical three-phase		symmetrical three-phase	
Typical cable size (mm² / AWG) 3)	95/000		95/000	
Motor cable type	symmetrical three-phase(Use of shielded cable is advisable)		symmetrical three-phase(Use of shielded cable is advisable)	
Typical cable size (mm² / AWG) 3)	25/4		25/4	
Motor cable Max. length 4)	3280 ft (1000 m)		3280 ft (1000 m)	
Grounding connection PE (mm² / AWG)	50/0		50/0	
Control power supply	single phase, 230V, 50/60Hz		single phase, 230V, 50/60Hz	
Capacity of control power supply w/o options	1 kVA		1 kVA	
Capacity of control power supply with options	"depending on options to be used"		"depending on options to be used"	
Fan power supply	3-phase 400 Vac, 50Hz		3-phase 400 Vac, 50Hz	
Capacity of fan power supply (kVA) 5)	6		6	
Maintenance				
Maintenance access	Front		Front	
Cable entry 6)	Bottom in /Bottom out		Bottom in /Bottom out	

ATV6000	D890A6666NA●	
Nominal data	Normal Duty	Heavy Duty
Type rating [kVA]	890	
Max. Motor power [kW] / [HP] 1)	710/952	670/898
Nominal Continuous output current [A] 1)	74.3	71
Max. output current with 120 %overload 1 min / 10 min [A]	89.1	/
Max. output current with 150 % overload1 min / 10 min [A]	/	107
Power cells		
Number of cells per phase	5	
Power cell rated current [A]	100	
Power cell current with 120 %overload 1 min / 10 min [A]	120	
Max. output current for 3 sec [A]	150	
Characteristics with standard efficiency		
Efficiency at 100 % load (incl. Transformer) [%]	96.0%	
Total losses at 100 % load [kW]	30.9	29.2
Air flow [m ³ /h]	9889	
Noise level [dB (A)] @ 50 Hz	80	
Weight [kg / lb]	3681/8098	
Dimension [mm / inch] W*D*H 2)	2760*1400*2618/108.8*55.2*103.2	
Connection		
Incoming cable type	symmetrical three-phase	
Typical cable size (mm ² / AWG) 3)	95/000	
Motor cable type	symmetrical three-phase(Use of shielded cable is advisable)	
Typical cable size (mm ² / AWG) 3)	25/4	
Motor cable Max. length 4)	3280 ft (1000 m)	
Grounding connection PE (mm ² / AWG)	50/0	
Control power supply	single phase, 230V, 50/60Hz	
Capacity of control power supply w/o options	1 kVA	
Capacity of control power supply with options	"depending on options to be used"	
Fan power supply	3-phase 400 Vac, 50Hz	
Capacity of fan power supply (kVA) 5)	6	
Maintenance		
Maintenance access	Front	
Cable entry 6)	Bottom in /Bottom out	
<p>1) Values valid for synchronous motor and asynchronous motor. The specifications for the maximum motor shaft power is based on a motor efficiency of 95%.</p> <p>2) Including the height of top cooling fans.</p> <p>3) For CE products: Typical cable size values based on use of copper cables in cable tray laying. Incoming cable size is based on drive current rating. It has to be checked to be in accordance to mains short circuit capability and local and national electrical code requirement as well all other applicable regulations.</p> <p>4) Variation in max. cable length may be possible depending on type cable and installation. For longer cable length between motor and drive contact Schneider Electric.</p> <p>5) Contact Schneider Electric if N+1 redundancy cooling fan requested.</p> <p>6) For other combination contact Schneider Electric.</p>		

ATV6000C100A6666

ATV6000	C100A6666NA•	
Nominal data	Normal Duty	Heavy Duty
Type rating [kVA]	1000	
Max. Motor power [kW] / [HP] 1)	800/1072	760/1019
Nominal Continuous output current [A] 1)	83.7	80
Max. output current with 120 %overload 1 min / 10 min [A]	100	/
Max. output current with 150 % overload 1 min / 10 min [A]	/	120
Power cells		
Number of cells per phase	5	
Power cell rated current [A]	100	
Power cell current with 120 %overload 1 min / 10 min [A]	120	
Max. output current for 3 sec [A]	150	
Characteristics with standard efficiency		
Efficiency at 100 % load (incl. Transformer) [%]	96.0%	
Total losses at 100 % load [kW]	34.9	33.1
Air flow [m ³ /h]	11940	
Noise level [dB (A)] @ 50 Hz	80	
Weight [kg / lb]	3948/8686	
Dimension [mm / inch] W*D*H 2)	3060*1400*2618/120.6*55.2*103.2	
Connection		
Incoming cable type	symmetrical three-phase	
Typical cable size (mm ² / AWG) 3)	95/000	
Motor cable type	symmetrical three-phase(Use of shielded cable is advisable)	
Typical cable size (mm ² / AWG) 3)	25/4	
Motor cable Max. length 4)	3280 ft (1000 m)	
Grounding connection PE (mm ² / AWG)	50/0	
Control power supply	single phase, 230V, 50/60Hz	
Capacity of control power supply w/o options	1 kVA	
Capacity of control power supply with options	"depending on options to be used"	
Fan power supply	3-phase 400 Vac, 50Hz	
Capacity of fan power supply (kVA) 5)	7	
Maintenance		
Maintenance access	Front	
Cable entry 6)	Bottom in /Bottom out	
<p>1) Values valid for synchronous motor and asynchronous motor. The specifications for the maximum motor shaft power is based on a motor efficiency of 95%.</p> <p>2) Including the height of top cooling fans.</p> <p>3) For CE products: Typical cable size values based on use of copper cables in cable tray laying. Incoming cable size is based on drive current rating. It has to be checked to be in accordance to mains short circuit capability and local and national electrical code requirement as well all other applicable regulations.</p> <p>4) Variation in max. cable length may be possible depending on type cable and installation. For longer cable length between motor and drive contact Schneider Electric.</p> <p>5) Contact Schneider Electric if N+1 redundancy cooling fan requested.</p> <p>6) For other combination contact Schneider Electric.</p>		

ATV6000C119A6666

ATV6000	C119A6666NA●	
Nominal data	Normal Duty	Heavy Duty
Type rating [kVA]	1190	
Max. Motor power [kW] / [HP] 1)	950/1273	760/1019
Nominal Continuous output current [A] 1)	100	80
Max. output current with 120 %overload 1 min / 10 min [A]	120	/
Max. output current with 150 % overload 1 min / 10 min [A]	/	120
Power cells		
Number of cells per phase	6	
Power cell rated current [A]	100	
Power cell current with 120 %overload 1 min / 10 min [A]	120	
Max. output current for 3 sec [A]	150	
Characteristics with standard efficiency		
Efficiency at 100 % load (incl. Transformer) [%]	96.0%	
Total losses at 100 % load [kW]	41.4	33.1
Air flow [m ³ /h]	11840	
Noise level [dB (A)] @ 50 Hz	80	
Weight [kg / lb]	4453/9797	
Dimension [mm / inch] W*D*H 2)	3360*1400*2604/132.4*55.2*102.6	
Connection		
Incoming cable type	symmetrical three-phase	
Typical cable size (mm ² / AWG) 3)	95/000	
Motor cable type	symmetrical three-phase(Use of shielded cable is advisable)	
Typical cable size (mm ² / AWG) 3)	25/4	
Motor cable Max. length 4)	3280 ft (1000 m)	
Grounding connection PE (mm ² / AWG)	50/0	
Control power supply	single phase, 230V, 50/60Hz	
Capacity of control power supply w/o options	1 kVA	
Capacity of control power supply with options	"depending on options to be used"	
Fan power supply	3-phase 400 Vac, 50Hz	
Capacity of fan power supply (kVA) 5)	5	
Maintenance		
Maintenance access	Front	
Cable entry 6)	Bottom in /Bottom out	
<p>1) Values valid for synchronous motor and asynchronous motor. The specifications for the maximum motor shaft power is based on a motor efficiency of 95%.</p> <p>2) Including the height of top cooling fans.</p> <p>3) For CE products: Typical cable size values based on use of copper cables in cable tray laying. Incoming cable size is based on drive current rating. It has to be checked to be in accordance to mains short circuit capability and local and national electrical code requirement as well all other applicable regulations.</p> <p>4) Variation in max. cable length may be possible depending on type cable and installation. For longer cable length between motor and drive contact Schneider Electric.</p> <p>5) Contact Schneider Electric if N+1 redundancy cooling fan requested.</p> <p>6) For other combination contact Schneider Electric.</p>		

ATV6000C138A6666

ATV6000	C138A6666NA●	
Nominal data	Normal Duty	Heavy Duty
Type rating [kVA]	1380	
Max. Motor power [kW] / [HP] 1)	1100/1475	1050/1408
Nominal Continuous output current [A] 1)	115	110
Max. output current with 120 %overload 1 min / 10 min [A]	138	/
Max. output current with 150 % overload 1 min / 10 min [A]	/	165
Power cells		
Number of cells per phase	5	
Power cell rated current [A]	150	
Power cell current with 120 %overload 1 min / 10 min [A]	180	
Max. output current for 3 sec [A]	225	
Characteristics with standard efficiency		
Efficiency at 100 % load (incl. Transformer) [%]	96.0%	
Total losses at 100 % load [kW]	47.9	45.7
Air flow [m ³ /h]	17100	
Noise level [dB (A)] @ 50 Hz	83	
Weight [kg / lb]	5045/11099	
Dimension [mm / inch] W*D*H 2)	3660*1400*2618/144.3*55.2*103.2	
Connection		
Incoming cable type	symmetrical three-phase	
Typical cable size (mm ² / AWG) 3)	95/000	
Motor cable type	symmetrical three-phase(Use of shielded cable is advisable)	
Typical cable size (mm ² / AWG) 3)	35/2	
Motor cable Max. length 4)	3280 ft (1000 m)	
Grounding connection PE (mm ² / AWG)	50/0	
Control power supply	single phase, 230V, 50/60Hz	
Capacity of control power supply w/o options	1 kVA	
Capacity of control power supply with options	"depending on options to be used"	
Fan power supply	3-phase 400 Vac, 50Hz	
Capacity of fan power supply (kVA) 5)	10	
Maintenance		
Maintenance access	Front	
Cable entry 6)	Bottom in /Bottom out	
<p>1) Values valid for synchronous motor and asynchronous motor. The specifications for the maximum motor shaft power is based on a motor efficiency of 95%.</p> <p>2) Including the height of top cooling fans.</p> <p>3) For CE products: Typical cable size values based on use of copper cables in cable tray laying. Incoming cable size is based on drive current rating. It has to be checked to be in accordance to mains short circuit capability and local and national electrical code requirement as well all other applicable regulations.</p> <p>4) Variation in max. cable length may be possible depending on type cable and installation. For longer cable length between motor and drive contact Schneider Electric.</p> <p>5) Contact Schneider Electric if N+1 redundancy cooling fan requested.</p> <p>6) For other combination contact Schneider Electric.</p>		

ATV6000C163A6666

ATV6000	C163A6666NA●	
Nominal data	Normal Duty	Heavy Duty
Type rating [kVA]	1630	
Max. Motor power [kW] / [HP] 1)	1300/1743	1140/1528
Nominal Continuous output current [A] 1)	136	120
Max. output current with 120 %overload 1 min / 10 min [A]	163	/
Max. output current with 150 % overload 1 min / 10 min [A]	/	180
Power cells		
Number of cells per phase	5	
Power cell rated current [A]	150	
Power cell current with 120 %overload 1 min / 10 min [A]	180	
Max. output current for 3 sec [A]	225	
Characteristics with standard efficiency		
Efficiency at 100 % load (incl. Transformer) [%]	96.0%	
Total losses at 100 % load [kW]	56.6	49.6
Air flow [m ³ /h]	17100	
Noise level [dB (A)] @ 50 Hz	83	
Weight [kg / lb]	5409/11900	
Dimension [mm / inch] W*D*H 2)	3660*1500*2754/144.3*59.1*108.6	
Connection		
Incoming cable type	symmetrical three-phase	
Typical cable size (mm ² / AWG) 3)	95/000	
Motor cable type	symmetrical three-phase(Use of shielded cable is advisable)	
Typical cable size (mm ² / AWG) 3)	35/2	
Motor cable Max. length 4)	3280 ft (1000 m)	
Grounding connection PE (mm ² / AWG)	50/0	
Control power supply	single phase, 230V, 50/60Hz	
Capacity of control power supply w/o options	1 kVA	
Capacity of control power supply with options	"depending on options to be used"	
Fan power supply	3-phase 400 Vac, 50Hz	
Capacity of fan power supply (kVA) 5)	10	
Maintenance		
Maintenance access	Front	
Cable entry 6)	Bottom in /Bottom out	
<p>1) Values valid for synchronous motor and asynchronous motor. The specifications for the maximum motor shaft power is based on a motor efficiency of 95%.</p> <p>2) Including the height of top cooling fans.</p> <p>3) For CE products: Typical cable size values based on use of copper cables in cable tray laying. Incoming cable size is based on drive current rating. It has to be checked to be in accordance to mains short circuit capability and local and national electrical code requirement as well all other applicable regulations.</p> <p>4) Variation in max. cable length may be possible depending on type cable and installation. For longer cable length between motor and drive contact Schneider Electric.</p> <p>5) Contact Schneider Electric if N+1 redundancy cooling fan requested.</p> <p>6) For other combination contact Schneider Electric.</p>		

ATV6000C179A6666

ATV6000	C179A6666NA●	
Nominal data	Normal Duty	Heavy Duty
Type rating [kVA]	1790	
Max. Motor power [kW] / [HP] 1)	1430/1917	1140/1528
Nominal Continuous output current [A] 1)	150	120
Max. output current with 120 %overload 1 min / 10 min [A]	180	/
Max. output current with 150 % overload 1 min / 10 min [A]	/	180
Power cells		
Number of cells per phase	6	
Power cell rated current [A]	150	
Power cell current with 120 %overload 1 min / 10 min [A]	180	
Max. output current for 3 sec [A]	225	
Characteristics with standard efficiency		
Efficiency at 100 % load (incl. Transformer) [%]	96.0%	
Total losses at 100 % load [kW]	62.2	49.6
Air flow [m ³ /h]	19430	
Noise level [dB (A)] @ 50 Hz	83	
Weight [kg / lb]	5867/12907	
Dimension [mm / inch] W*D*H 2)	3960*1500*2754/156.1*59.1*108.6	
Connection		
Incoming cable type	symmetrical three-phase	
Typical cable size (mm ² / AWG) 3)	95/000	
Motor cable type	symmetrical three-phase(Use of shielded cable is advisable)	
Typical cable size (mm ² / AWG) 3)	35/2	
Motor cable Max. length 4)	3280 ft (1000 m)	
Grounding connection PE (mm ² / AWG)	50/0	
Control power supply	single phase, 230V, 50/60Hz	
Capacity of control power supply w/o options	1 kVA	
Capacity of control power supply with options	"depending on options to be used"	
Fan power supply	3-phase 400 Vac, 50Hz	
Capacity of fan power supply (kVA) 5)	13	
Maintenance		
Maintenance access	Front	
Cable entry 6)	Bottom in /Bottom out	
<p>1) Values valid for synchronous motor and asynchronous motor. The specifications for the maximum motor shaft power is based on a motor efficiency of 95%.</p> <p>2) Including the height of top cooling fans.</p> <p>3) For CE products: Typical cable size values based on use of copper cables in cable tray laying. Incoming cable size is based on drive current rating. It has to be checked to be in accordance to mains short circuit capability and local and national electrical code requirement as well all other applicable regulations.</p> <p>4) Variation in max. cable length may be possible depending on type cable and installation. For longer cable length between motor and drive contact Schneider Electric.</p> <p>5) Contact Schneider Electric if N+1 redundancy cooling fan requested.</p> <p>6) For other combination contact Schneider Electric.</p>		

ATV6000C200A6666...ATV6000C225A6666

ATV6000	C200A6666NA●		C225A6666NA●	
Nominal data	Normal Duty	Heavy Duty	Normal Duty	Heavy Duty
Type rating [kVA]	2000		2250	
Max. Motor power [kW] / [HP] 1)	1600/2145	1520/2038	1800/2413	1520/2038
Nominal Continuous output current [A] 1)	167	160	188	160
Max. output current with 120 %overload 1 min / 10 min [A]	201	/	226	/
Max. output current with 150 % overload 1 min / 10 min [A]	/	240	/	240
Power cells				
Number of cells per phase	5		5	
Power cell rated current [A]	200		200	
Power cell current with 120 %overload 1 min / 10 min [A]	240		240	
Max. output current for 3 sec [A]	300		300	
Characteristics with standard efficiency				
Efficiency at 100 % load (incl. Transformer) [%]	96.0%		96.0%	
Total losses at 100 % load [kW]	69.6	66.1	78.3	66.1
Air flow [m ³ /h]	18912		18912	
Noise level [dB (A)] @ 50 Hz	80		80	
Weight [kg / lb]	6521/14346		6831/15028	
Dimension [mm / inch] W*D*H 2)	4660*1500*2754/ 183.7*59.1*108.6		4660*1500*2754/ 183.7*59.1*108.6	
Connection				
Incoming cable type	symmetrical three-phase		symmetrical three-phase	
Typical cable size (mm ² / AWG) 3)	95/000		95/000	
Motor cable type	symmetrical three-phase(Use of shielded cable is advisable)		symmetrical three-phase(Use of shielded cable is advisable)	
Typical cable size (mm ² / AWG) 3)	35/2		50/0	
Motor cable Max. length 4)	3280 ft (1000 m)		3280 ft (1000 m)	
Grounding connection PE (mm ² / AWG)	50/0		50/0	
Control power supply	single phase, 230V, 50/60Hz		single phase, 230V, 50/60Hz	
Capacity of control power supply w/o options	1 kVA		1 kVA	
Capacity of control power supply with options	"depending on options to be used"		"depending on options to be used"	
Fan power supply	3-phase 400 Vac, 50Hz		3-phase 400 Vac, 50Hz	
Capacity of fan power supply (kVA) 5)	8		8	
Maintenance				
Maintenance access	Front		Front	
Cable entry 6)	Bottom in /Bottom out		Bottom in /Bottom out	
1) Values valid for synchronous motor and asynchronous motor. The specifications for the maximum motor shaft power is based on a motor efficiency of 95%. 2) Including the height of top cooling fans. 3) For CE products: Typical cable size values based on use of copper cables in cable tray laying. Incoming cable size is based on drive current rating. It has to be checked to be in accordance to mains short circuit capability and local and national electrical code requirement as well all other applicable regulations. 4) Variation in max. cable length may be possible depending on type cable and installation. For longer cable length between motor and drive contact Schneider Electric. 5) Contact Schneider Electric if N+1 redundancy cooling fan requested. 6) For other combination contact Schneider Electric.				

ATV6000C263A6666...ATV6000C288A6666

ATV6000	C263A6666NA●		C288A6666NA●	
Nominal data	Normal Duty	Heavy Duty	Normal Duty	Heavy Duty
Type rating [kVA]	2630		2880	
Max. Motor power [kW] / [HP] 1)	2100/2816	2010/2695	2300/3084	2140/2869
Nominal Continuous output current [A] 1)	220	211	241	224
Max. output current with 120 %overload 1 min / 10 min [A]	264	/	289	/
Max. output current with 150 % overload 1 min / 10 min [A]	/	317	/	336
Power cells				
Number of cells per phase	5		5	
Power cell rated current [A]	280		280	
Power cell current with 120 %overload 1 min / 10 min [A]	336		336	
Max. output current for 3 sec [A]	420		420	
Characteristics with standard efficiency				
Efficiency at 100 % load (incl. Transformer) [%]	96.0%		96.0%	
Total losses at 100 % load [kW]	91.3	87.4	100.0	93.1
Air flow [m³/h]	25440		25440	
Noise level [dB (A)] @ 50 Hz	83		83	
Weight [kg / lb]	7384/16245		7694/16927	
Dimension [mm / inch] W*D*H 2)	4660*1600*2754/ 183.7*63.1*108.6		4660*1600*2754/ 183.7*63.1*108.6	
Connection				
Incoming cable type	symmetrical three-phase		symmetrical three-phase	
Typical cable size (mm² / AWG) 3)	95/000		95/000	
Motor cable type	symmetrical three-phase(Use of shielded cable is advisable)		symmetrical three-phase(Use of shielded cable is advisable)	
Typical cable size (mm² / AWG) 3)	70/00		70/00	
Motor cable Max. length 4)	3280 ft (1000 m)		3280 ft (1000 m)	
Grounding connection PE (mm² / AWG)	50/0		50/0	
Control power supply	single phase, 230V, 50/60Hz		single phase, 230V, 50/60Hz	
Capacity of control power supply w/o options	1 kVA		1 kVA	
Capacity of control power supply with options	"depending on options to be used"		"depending on options to be used"	
Fan power supply	3-phase 400 Vac, 50Hz		3-phase 400 Vac, 50Hz	
Capacity of fan power supply (kVA) 5)	15		15	
Maintenance				
Maintenance access	Front		Front	
Cable entry 6)	Bottom in /Bottom out		Bottom in /Bottom out	
1) Values valid for synchronous motor and asynchronous motor. The specifications for the maximum motor shaft power is based on a motor efficiency of 95%. 2) Including the height of top cooling fans. 3) For CE products: Typical cable size values based on use of copper cables in cable tray laying. Incoming cable size is based on drive current rating. It has to be checked to be in accordance to mains short circuit capability and local and national electrical code requirement as well all other applicable regulations. 4) Variation in max. cable length may be possible depending on type cable and installation. For longer cable length between motor and drive contact Schneider Electric. 5) Contact Schneider Electric if N+1 redundancy cooling fan requested. 6) For other combination contact Schneider Electric.				

ATV6000C334A6666

ATV6000	C334A6666NA•	
Nominal data	Normal Duty	Heavy Duty
Type rating [kVA]	3340	
Max. Motor power [kW] / [HP] 1)	2670/3580	2140/2869
Nominal Continuous output current [A] 1)	280	224
Max. output current with 120 %overload 1 min / 10 min [A]	336	/
Max. output current with 150 % overload 1 min / 10 min [A]	/	336
Power cells		
Number of cells per phase	6	
Power cell rated current [A]	280	
Power cell current with 120 %overload 1 min / 10 min [A]	336	
Max. output current for 3 sec [A]	420	
Characteristics with standard efficiency		
Efficiency at 100 % load (incl. Transformer) [%]	96.0%	
Total losses at 100 % load [kW]	116.0	93.1
Air flow [m ³ /h]	27634	
Noise level [dB (A)] @ 50 Hz	85	
Weight [kg / lb]	8799/19358	
Dimension [mm / inch] W*D*H 2)	5160*1700*2754/203.4*67*108.6	
Connection		
Incoming cable type	symmetrical three-phase	
Typical cable size (mm ² / AWG) 3)	95/000	
Motor cable type	symmetrical three-phase(Use of shielded cable is advisable)	
Typical cable size (mm ² / AWG) 3)	95/000	
Motor cable Max. length 4)	3280 ft (1000 m)	
Grounding connection PE (mm ² / AWG)	50/0	
Control power supply	single phase, 230V, 50/60Hz	
Capacity of control power supply w/o options	1 kVA	
Capacity of control power supply with options	"depending on options to be used"	
Fan power supply	3-phase 400 Vac, 50Hz	
Capacity of fan power supply (kVA) 5)	19	
Maintenance		
Maintenance access	Front	
Cable entry 6)	Bottom in /Bottom out	
<p>1) Values valid for synchronous motor and asynchronous motor. The specifications for the maximum motor shaft power is based on a motor efficiency of 95%.</p> <p>2) Including the height of top cooling fans.</p> <p>3) For CE products: Typical cable size values based on use of copper cables in cable tray laying. Incoming cable size is based on drive current rating. It has to be checked to be in accordance to mains short circuit capability and local and national electrical code requirement as well all other applicable regulations.</p> <p>4) Variation in max. cable length may be possible depending on type cable and installation. For longer cable length between motor and drive contact Schneider Electric.</p> <p>5) Contact Schneider Electric if N+1 redundancy cooling fan requested.</p> <p>6) For other combination contact Schneider Electric.</p>		

ATV6000C382A6666...ATV6000C538A6666

ATV6000	C382A6666NA●		C425A6666NA●	
Nominal data	Normal Duty	Heavy Duty	Normal Duty	Heavy Duty
Type rating [kVA]	3820		4250	
Max. Motor power [kW] / [HP] 1)	3050/4090	2930/3929	3400/4559	3130/4197
Nominal Continuous output current [A] 1)	320	307	356	328
Max. output current with 120 %overload 1 min / 10 min [A]	384	/	427	/
Max. output current with 150 % overload1 min / 10 min [A]	/	461	/	492
Power cells				
Number of cells per phase	5		5	
Power cell rated current [A]	410		410	
Power cell current with 120 %overload 1 min / 10 min [A]	492		492	
Max. output current for 3 sec [A]	615		615	
Characteristics with standard efficiency				
Efficiency at 100 % load (incl. Transformer) [%]	96.0%		96.0%	
Total losses at 100 % load [kW]	132.5	127.3	147.8	136.0
Air flow [m³/h]	22464		26184	
Noise level [dB (A)] @ 50 Hz	83		83	
Weight [kg / lb]	10568/23250		11215/24673	
Dimension [mm / inch] W*D*H 2)	5960*1700*2754/ 234.9*67*108.6		5960*1700*2795/ 234.9*67*110.2	
Connection				
Incoming cable type	symmetrical three-phase		symmetrical three-phase	
Typical cable size (mm² / AWG) 3)	120/0000		150/300MCM	
Motor cable type	symmetrical three-phase(Use of shielded cable is advisable)		symmetrical three-phase(Use of shielded cable is advisable)	
Typical cable size (mm² / AWG) 3)	120/0000		150/300MCM	
Motor cable Max. length 4)	3280 ft (1000 m)		3280 ft (1000 m)	
Grounding connection PE (mm² / AWG)	50/0		70/00	
Control power supply	single phase, 230V, 50/60Hz		single phase, 230V, 50/60Hz	
Capacity of control power supply w/o options	1 kVA		1 kVA	
Capacity of control power supply with options	"depending on options to be used"		"depending on options to be used"	
Fan power supply	3-phase 400 Vac, 50Hz		3-phase 400 Vac, 50Hz	
Capacity of fan power supply (kVA) 5)	10		20	
Maintenance				
Maintenance access	Front		Front	
Cable entry 6)	Bottom in /Bottom out		Bottom in /Bottom out	

ATV6000	C489A6666NA●		C538A6666NA●	
Nominal data	Normal Duty	Heavy Duty	Normal Duty	Heavy Duty
Type rating [kVA]	4890		5380	
Max. Motor power [kW] / [HP] 1)	3910/5243	3740/5015	4300/5766	3740/5015
Nominal Continuous output current [A] 1)	410	392	450	392
Max. output current with 120 % overload 1 min / 10 min [A]	492	/	540	/
Max. output current with 150 % overload 1 min / 10 min [A]	/	588	/	588
Power cells				
Number of cells per phase	5		5	
Power cell rated current [A]	490		490	
Power cell current with 120 % overload 1 min / 10 min [A]	588		588	
Max. output current for 3 sec [A]	735		735	
Characteristics with standard efficiency				
Efficiency at 100 % load (incl. Transformer) [%]	96.0%		96.5%	
Total losses at 100 % load [kW]	169.9	162.5	162.8	141.6
Air flow [m ³ /h]	29400		29400	
Noise level [dB (A)] @ 50 Hz	83		83	
Weight [kg / lb]	11990/26378		12596/27711	
Dimension [mm / inch] W*D*H 2)	5960*1700*2795/ 234.9*67*110.2		5960*1700*2795/ 234.9*67*110.2	
Connection				
Incoming cable type	symmetrical three-phase		symmetrical three-phase	
Typical cable size (mm ² / AWG) 3)	185/350MCM		240/500MCM	
Motor cable type	symmetrical three-phase(Use of shielded cable is advisable)		symmetrical three-phase(Use of shielded cable is advisable)	
Typical cable size (mm ² / AWG) 3)	185/350MCM		240/500MCM	
Motor cable Max. length 4)	3280 ft (1000 m)		3280 ft (1000 m)	
Grounding connection PE (mm ² / AWG)	70/00		95/000	
Control power supply	single phase, 230V, 50/60Hz		single phase, 230V, 50/60Hz	
Capacity of control power supply w/o options	1 kVA		1 kVA	
Capacity of control power supply with options	"depending on options to be used"		"depending on options to be used"	
Fan power supply	3-phase 400 Vac, 50Hz		3-phase 400 Vac, 50Hz	
Capacity of fan power supply (kVA) 5)	22		22	
Maintenance				
Maintenance access	Front		Front	
Cable entry 6)	Bottom in /Bottom out		Bottom in /Bottom out	
<p>1) Values valid for synchronous motor and asynchronous motor. The specifications for the maximum motor shaft power is based on a motor efficiency of 95%.</p> <p>2) Including the height of top cooling fans.</p> <p>3) For CE products: Typical cable size values based on use of copper cables in cable tray laying. Incoming cable size is based on drive current rating. It has to be checked to be in accordance to mains short circuit capability and local and national electrical code requirement as well all other applicable regulations.</p> <p>4) Variation in max. cable length may be possible depending on type cable and installation. For longer cable length between motor and drive contact Schneider Electric.</p> <p>5) Contact Schneider Electric if N+1 redundancy cooling fan requested.</p> <p>6) For other combination contact Schneider Electric.</p>				

ATV6000C585A6666

ATV6000	C585A6666NA●	
Nominal data	Normal Duty	Heavy Duty
Type rating [kVA]	5850	
Max. Motor power [kW] / [HP] 1)	4680/6275	3740/5015
Nominal Continuous output current [A] 1)	490	392
Max. output current with 120 %overload 1 min / 10 min [A]	588	/
Max. output current with 150 % overload 1 min / 10 min [A]	/	588
Power cells		
Number of cells per phase	6	
Power cell rated current [A]	490	
Power cell current with 120 %overload 1 min / 10 min [A]	588	
Max. output current for 3 sec [A]	735	
Characteristics with standard efficiency		
Efficiency at 100 % load (incl. Transformer) [%]	96.5%	
Total losses at 100 % load [kW]	177.2	141.6
Air flow [m ³ /h]	33000	
Noise level [dB (A)] @ 50 Hz	83	
Weight [kg / lb]	14276/31407	
Dimension [mm / inch] W*D*H 2)	6860*1800*3155/270.3*71*124.4	
Connection		
Incoming cable type	symmetrical three-phase	
Typical cable size (mm ² / AWG) 3)	95*2/2*00	
Motor cable type	symmetrical three-phase(Use of shielded cable is advisable)	
Typical cable size (mm ² / AWG) 3)	240/500MCM	
Motor cable Max. length 4)	3280 ft (1000 m)	
Grounding connection PE (mm ² / AWG)	95/000	
Control power supply	single phase, 230V, 50/60Hz	
Capacity of control power supply w/o options	1 kVA	
Capacity of control power supply with options	"depending on options to be used"	
Fan power supply	3-phase 400 Vac, 50Hz	
Capacity of fan power supply (kVA) 5)	23	
Maintenance		
Maintenance access	Front	
Cable entry 6)	Bottom in /Bottom out	
<p>1) Values valid for synchronous motor and asynchronous motor. The specifications for the maximum motor shaft power is based on a motor efficiency of 95%.</p> <p>2) Including the height of top cooling fans.</p> <p>3) For CE products: Typical cable size values based on use of copper cables in cable tray laying. Incoming cable size is based on drive current rating. It has to be checked to be in accordance to mains short circuit capability and local and national electrical code requirement as well all other applicable regulations.</p> <p>4) Variation in max. cable length may be possible depending on type cable and installation. For longer cable length between motor and drive contact Schneider Electric.</p> <p>5) Contact Schneider Electric if N+1 redundancy cooling fan requested.</p> <p>6) For other combination contact Schneider Electric.</p>		

ATV6000C657A6666...ATV6000C713A6666

ATV6000	C657A6666NA●		C713A6666NA●	
Nominal data	Normal Duty	Heavy Duty	Normal Duty	Heavy Duty
Type rating [kVA]	6570		7130	
Max. Motor power [kW] / [HP] 1)	5250/7040	5040/6758	5700/7643	5470/7335
Nominal Continuous output current [A] 1)	550	528	596	573
Max. output current with 120 %overload 1 min / 10 min [A]	660	/	716	/
Max. output current with 150 % overload 1 min / 10 min [A]	/	792	/	860
Power cells				
Number of cells per phase	5		5	
Power cell rated current [A]	720		720	
Power cell current with 120 %overload 1 min / 10 min [A]	864		864	
Max. output current for 3 sec [A]	1080		1080	
Characteristics with standard efficiency				
Efficiency at 100 % load (incl. Transformer) [%]	96.5%		96.5%	
Total losses at 100 % load [kW]	198.7	190.8	215.8	207.0
Air flow [m ³ /h]	50400		50400	
Noise level [dB (A)] @ 50 Hz	85		85	
Weight [kg / lb]	16658/36648		17352/38174	
Dimension [mm / inch] W*D*H 2)	7960*1800*3155/ 313.7*71*124.4		7960*1800*3155/ 313.7*71*124.4	
Connection				
Incoming cable type	symmetrical three-phase		symmetrical three-phase	
Typical cable size (mm ² / AWG) 3)	95*2/2*000		120*2/2*0000	
Motor cable type	symmetrical three-phase(Use of shielded cable is advisable)		symmetrical three-phase(Use of shielded cable is advisable)	
Typical cable size (mm ² / AWG) 3)	95*2/2*000		95*2/2*000	
Motor cable Max. length 4)	1000 m		1000 m	
Grounding connection PE (mm ² / AWG)	95/000		120/0000	
Control power supply	single phase, 230V, 50/60Hz,		single phase, 230V, 50/60Hz,	
Capacity of control power supply w/o options	1 kVA		1 kVA	
Capacity of control power supply with options	"depending on options to be used"		"depending on options to be used"	
Fan power supply	3-phase 400 Vac, 50Hz		3-phase 400 Vac, 50Hz	
Capacity of fan power supply (kVA) 5)	32		32	
Maintenance				
Maintenance access	Front & Rear		Front & Rear	
Cable entry 6)	Bottom in /Bottom out		Bottom in /Bottom out	
<p>1) Values valid for synchronous motor and asynchronous motor. The specifications for the maximum motor shaft power is based on a motor efficiency of 95%.</p> <p>2) Including the height of top cooling fans.</p> <p>3) For CE products: Typical cable size values based on use of copper cables in cable tray laying. Incoming cable size is based on drive current rating. It has to be checked to be in accordance to mains short circuit capability and local and national electrical code requirement as well all other applicable regulations.</p> <p>4) Variation in max. cable length may be possible depending on type cable and installation. For longer cable length between motor and drive contact Schneider Electric.</p> <p>5) Contact Schneider Electric if N+1 redundancy cooling fan requested.</p> <p>6) For other combination contact Schneider Electric.</p>				

ATV6000C775A6666...ATV6000M120A6666

ATV6000	C775A6666NA●		C860A6666NA●	
Nominal data	Normal Duty	Heavy Duty	Normal Duty	Heavy Duty
Type rating [kVA]	7750		8600	
Max. Motor power [kW] / [HP] 1)	6200/8314	5500/7375	6880/9226	6490/8703
Nominal Continuous output current [A] 1)	649	576	720	680
Max. output current with 120 %overload 1 min / 10 min [A]	779	/	864	/
Max. output current with 150 % overload1 min / 10 min [A]	/	864	/	1020
Power cells				
Number of cells per phase	5		5	
Power cell rated current [A]	720		850	
Power cell current with 120 %overload 1 min / 10 min [A]	864		1020	
Max. output current for 3 sec [A]	1080		1275	
Characteristics with standard efficiency				
Efficiency at 100 % load (incl. Transformer) [%]	96.5%		96.5%	
Total losses at 100 % load [kW]	234.7	208.2	260.4	245.7
Air flow [m³/h]	58091		58091	
Noise level [dB (A)] @ 50 Hz	85		85	
Weight [kg / lb]	18254/40159		19410/42702	
Dimension [mm / inch] W*D*H 2)	8260*1800*3155/ 325.5*71*124.4		8260*1800*3155/ 325.5*71*124.4	
Connection				
Incoming cable type	symmetrical three-phase		symmetrical three-phase	
Typical cable size (mm² / AWG) 3)	120*2/2*0000		150*2/2*300MCM	
Motor cable type	symmetrical three-phase(Use of shielded cable is advisable)		symmetrical three-phase(Use of shielded cable is advisable)	
Typical cable size (mm² / AWG) 3)	120*2/2*0000		150*2/2*300MCM	
Motor cable Max. length 4)	1000 m		1000 m	
Grounding connection PE (mm² / AWG)	120/0000		120/0000	
Control power supply	single phase, 230V, 50/60Hz,		single phase, 230V, 50/60Hz,	
Capacity of control power supply w/o options	1 kVA		1 kVA	
Capacity of control power supply with options	"depending on options to be used"		"depending on options to be used"	
Fan power supply	3-phase 400 Vac, 50Hz		3-phase 400 Vac, 50Hz	
Capacity of fan power supply (kVA) 5)	37		37	
Maintenance				
Maintenance access	Front & Rear		Front & Rear	
Cable entry 6)	Bottom in /Bottom out		Bottom in /Bottom out	

ATV6000	C925A6666NA●		M102A6666NA●	
Nominal data	Normal Duty	Heavy Duty	Normal Duty	Heavy Duty
Type rating [kVA]	9250		10200	
Max. Motor power [kW] / [HP] 1)	7400/9923	6490/8703	8120/10889	7640/10245
Nominal Continuous output current [A] 1)	774	680	850	800
Max. output current with 120 %overload 1 min / 10 min [A]	929	/	1020	/
Max. output current with 150 % overload1 min / 10 min [A]	/	1020	/	1200
Power cells				
Number of cells per phase	5		5	
Power cell rated current [A]	850		1000	
Power cell current with 120 %overload 1 min / 10 min [A]	1020		1200	
Max. output current for 3 sec [A]	1275		1500	
Characteristics with standard efficiency				
Efficiency at 100 % load (incl. Transformer) [%]	96.5%		96.5%	
Total losses at 100 % load [kW]	280.1	245.7	307.3	289.2
Air flow [m ³ /h]	60131		60131	
Noise level [dB (A)] @ 50 Hz	85		85	
Weight [kg / lb]	20215/44473		21496/47291	
Dimension [mm / inch] W*D*H 2)	8260*1800*3155/ 325.5*71*124.4		8260*1800*3155/ 325.5*71*124.4	
Connection				
Incoming cable type	symmetrical three-phase		symmetrical three-phase	
Typical cable size (mm ² / AWG) 3)	185*2/2*350MCM		240*2/2*500MCM	
Motor cable type	symmetrical three-phase(Use of shielded cable is advisable)		symmetrical three-phase(Use of shielded cable is advisable)	
Typical cable size (mm ² / AWG) 3)	240*2/2*500MCM		240*2/2*500MCM	
Motor cable Max. length 4)	1000 m		1000 m	
Grounding connection PE (mm ² / AWG)	150/300MCM		150/300MCM	
Control power supply	single phase, 230V, 50/60Hz,		single phase, 230V, 50/60Hz,	
Capacity of control power supply w/o options	1 kVA		1 kVA	
Capacity of control power supply with options	"depending on options to be used"		"depending on options to be used"	
Fan power supply	3-phase 400 Vac, 50Hz		3-phase 400 Vac, 50Hz	
Capacity of fan power supply (kVA) 5)	44		44	
Maintenance				
Maintenance access	Front & Rear		Front & Rear	
Cable entry 6)	Bottom in /Bottom out		Bottom in /Bottom out	

ATV6000	M110A6666NA●		M120A6666NA●	
Nominal data	Normal Duty	Heavy Duty	Normal Duty	Heavy Duty
Type rating [kVA]	11000		12000	
Max. Motor power [kW] / [HP] 1)	8800/11800	7640/10245	9550/12806	7640/10245
Nominal Continuous output current [A] 1)	921	800	1000	800
Max. output current with 120 %overload 1 min / 10 min [A]	1105	/	1200	/
Max. output current with 150 % overload 1 min / 10 min [A]	/	1200	/	1200
Power cells				
Number of cells per phase	5		6	
Power cell rated current [A]	1000		1000	
Power cell current with 120 %overload 1 min / 10 min [A]	1200		1200	
Max. output current for 3 sec [A]	1500		1500	
Characteristics with standard efficiency				
Efficiency at 100 % load (incl. Transformer) [%]	96.5%		96.5%	
Total losses at 100 % load [kW]	333.1	289.2	361.4	289.2
Air flow [m³/h]	60131		66179	
Noise level [dB (A)] @ 50 Hz	85		85	
Weight [kg / lb]	22487/49471		24804/54569	
Dimension [mm / inch] W*D*H 2)	8260*1800*3155/ 325.5*71*124.4		9060*1800*3155/357*71*124.4	
Connection				
Incoming cable type	symmetrical three-phase		symmetrical three-phase	
Typical cable size (mm² / AWG) 3)	240*2/2*500MCM		150*3/3*300MCM	
Motor cable type	symmetrical three-phase(Use of shielded cable is advisable)		symmetrical three-phase(Use of shielded cable is advisable)	
Typical cable size (mm² / AWG) 3)	240*2/2*500MCM		240*2/2*500MCM	
Motor cable Max. length 4)	1000 m		1000 m	
Grounding connection PE (mm² / AWG)	185/350MCM		185/350MCM	
Control power supply	single phase, 230V, 50/60Hz,		single phase, 230V, 50/60Hz,	
Capacity of control power supply w/o options	1 kVA		1 kVA	
Capacity of control power supply with options	"depending on options to be used"		"depending on options to be used"	
Fan power supply	3-phase 400 Vac, 50Hz		3-phase 400 Vac, 50Hz	
Capacity of fan power supply (kVA) 5)	44		49	
Maintenance				
Maintenance access	Front & Rear		Front & Rear	
Cable entry 6)	Bottom in /Bottom out		Bottom in /Bottom out	
1) Values valid for synchronous motor and asynchronous motor. The specifications for the maximum motor shaft power is based on a motor efficiency of 95%. 2) Including the height of top cooling fans. 3) For CE products: Typical cable size values based on use of copper cables in cable tray laying. Incoming cable size is based on drive current rating. It has to be checked to be in accordance to mains short circuit capability and local and national electrical code requirement as well all other applicable regulations. 4) Variation in max. cable length may be possible depending on type cable and installation. For longer cable length between motor and drive contact Schneider Electric. 5) Contact Schneider Electric if N+1 redundancy cooling fan requested. 6) For other combination contact Schneider Electric.				

Layout Drawing and Dimensions

Layout Drawing

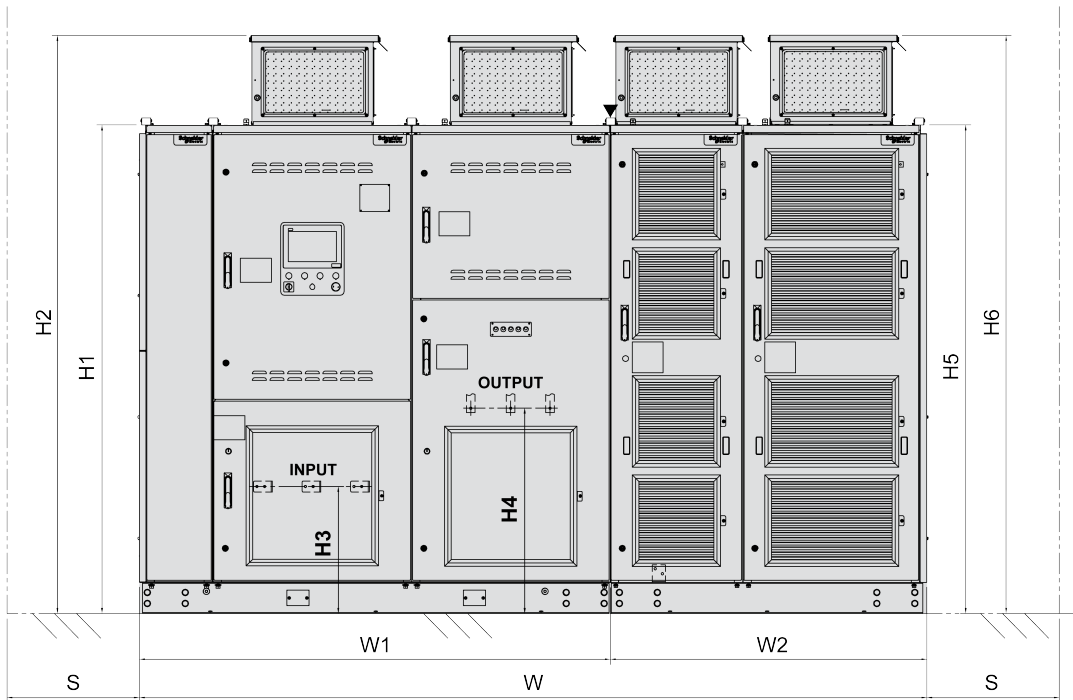

INPUT: Input terminal

OUTPUT: Output terminal

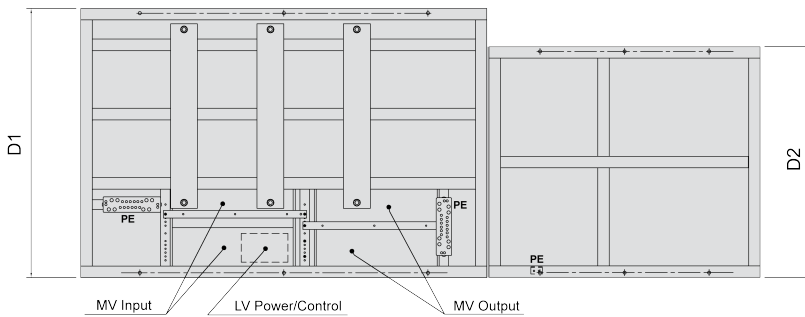

MV Input: MV Input cable area

LV Power/Control: LV Power/Control cable area

MV Output: MV Output cable area

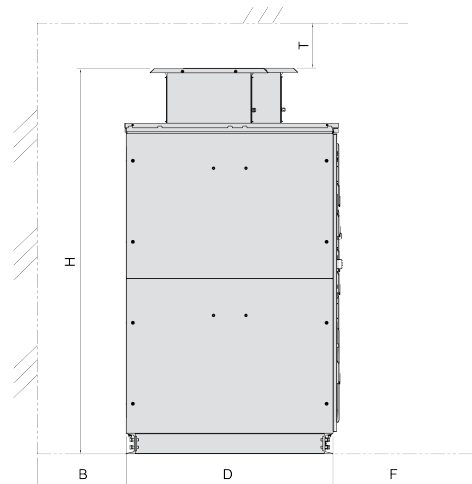

NOTE: Sketch is representing outline dimensions only, real cabinet arrangement is depending on power size.

Main dimensions - Output Voltage 6.6 kV

Product reference	Outer dimensions (mm / in)			Transformer cabinet			Powercell cabinet		
	W	H ^(b)	D	Fan Type	Fan Number	Weight [kg / lb]	Fan Type	Fan number	Weight [kg / lb]
ATV6000D450A6666...	2760	2618	1400	400	2	2291.4	500	1	844.7
	109	103	55			5041.1			1858.3
ATV6000D570A6666...	2760	2618	1400	400	2	2439.9	500	1	844.7
	109	103	55			5367.8			1858.3
ATV6000D630A6666...	2760	2618	1400	400	2	2514.2	500	1	844.7
	109	103	55			5531.2			1858.3
ATV6000D780A6666...	2760	2618	1400	400	2	2699.9	500	1	844.7
	109	103	55			5939.8			1858.3
ATV6000D890A6666...	2760	2618	1400	400	2	2836.1	500	1	844.7
	109	103	55			6239.4			1858.3
ATV6000C100A6666...	3060	2618	1400	450	2	3102.8	500	1	844.7
	120	103	55			6826.2			1858.3
ATV6000C119A6666...	3360	2604	1400	450	2	3338	400	2	1114.3
	132	103	55			7343.6			2451.5
ATV6000C138A6666...	3660	2618	1400	450	2	3573.2	500	2	1471
	144	103	55			7861			3236.2
ATV6000C163A6666...	3660	2754	1500	450	2	3938	500	2	1471
	144	108	59			8663.6			3236.2
ATV6000C179A6666...	3960	2754	1500	450	2	4136.1	560	2	1730.4
	156	108	59			9099.4			3806.9
ATV6000C200A6666...	4660	2754	1500	450	3	4518.9	400	3	2002
	183	108	59			9941.6			4404.4
ATV6000C225A6666...	4660	2754	1500	450	3	4828.4	400	3	2002
	183	108	59			10622.5			4404.4
ATV6000C263A6666...	4660	2754	1600	450	3	5339.4	500	3	2044.3
	183	108	63			11746.7			4497.5
ATV6000C288A6666...	4660	2754	1600	450	3	5648.9	500	3	2044.3
	183	108	63			12427.6			4497.5
ATV6000C334A6666...	5160	2754	1700	450	3	6282.6	560	3	2516.2
	203	108	67			13821.7			5535.6
ATV6000C382A6666...	5960	2754	1700	450	3	6874.3	400	5	3693.2
	235	108	67			15123.5			8125
ATV6000C425A6666...	5960	2795	1700	560	3	7521.3	400	5	3693.2
	235	110	67			16546.9			8125
ATV6000C489A6666...	5960	2795	1700	560	3	8313.6	450	5	3675.7
	235	110	67			18289.9			8086.5
ATV6000C538A6666...	5960	2795	1700	560	3	8920.3	450	5	3675.7
	235	110	67			19624.7			8086.5
ATV6000C585A6666...	6860	3155	1800	560	3	9921.7	450	6	4353.9
	270	124	71			21827.7			9578.6

Product reference	Outer dimensions (mm / in)			Transformer cabinet			Powercell cabinet		
	W	H ^(b)	D	Fan Type	Fan Number	Weight [kg / lb]	Fan Type	Fan number	Weight [kg / lb]
ATV6000C657A6666...	7960	3155	1800	560	3	10918.2	500	5	5739.7
	313	124	71			24020			12627.3
ATV6000C713A6666...	7960	3155	1800	560	3	11611.5	500	5	5739.7
	313	124	71			25545.3			12627.3
ATV6000C775A6666...	8260	3155	1800	560	4	12514.3	500	5	5739.7
	325	124	71			27531.5			12627.3
ATV6000C860A6666...	8260	3155	1800	560	4	13566.6	560	5	5842.7
	325	124	71			29846.5			12853.9
ATV6000C925A6666...	8260	3155	1800	560	4	14371.4	560	5	5842.7
	325	124	71			31617.1			12853.9
ATV6000M102A6666...	8260	3155	1800	560	4	15537.9	560	5	5957.7
	325	124	71			34183.4			13106.9
ATV6000M110A6666...	8260	3155	1800	560	4	16528.4	560	5	5957.7
	325	124	71			36362.5			13106.9
ATV6000M120A6666...	9060	3155	1800	560	4	17766.5	560	6	7037.3
	357	124	71			39086.3			15482.1

a) "H" is linked to higher size of transformer cabinet (H2) or transformer cabinet (H6).

Additional Dimensions - Output Voltage 6.6 kV

Product reference	Transformer Cabinet						Power cell Cabinet				Space Maintenance			
	(mm / in)						(mm / in)				(mm / in)			
	H1	H2	H3	H4	W1	D1	H5	H6	W2	D2	T	B (a)	F (b)	S (c)
ATV6000D450A6666...	2210	2540	500	780	1830	1400	2210	2618	930	1200	≥500	0	1500	0
	87	100	20	31	72	55	87	103	37	47	≥20	0	59	0
ATV6000D570A6666...	2210	2540	500	780	1830	1400	2210	2618	930	1200	≥500	0	1500	0
	87	100	20	31	72	55	87	103	37	47	≥20	0	59	0
ATV6000D630A6666...	2210	2540	500	780	1830	1400	2210	2618	930	1200	≥500	0	1500	0
	87	100	20	31	72	55	87	103	37	47	≥20	0	59	0
ATV6000D780A6666...	2210	2540	500	780	1830	1400	2210	2618	930	1200	≥500	0	1500	0
	87	100	20	31	72	55	87	103	37	47	≥20	0	59	0
ATV6000D890A6666...	2210	2540	500	780	1830	1400	2210	2618	930	1200	≥500	0	1500	0
	87	100	20	31	72	55	87	103	37	47	≥20	0	59	0
ATV6000C100A6666...	2210	2604	500	780	2130	1400	2210	2618	930	1200	≥500	0	1500	0
	87	103	20	31	84	55	87	103	37	47	≥20	0	59	0
ATV6000C119A6666...	2210	2604	500	780	2130	1400	2210	2540	1230	1200	≥500	0	1500	0
	87	103	20	31	84	55	87	100	48	47	≥20	0	59	0
ATV6000C138A6666...	2210	2604	500	780	2130	1400	2210	2618	1530	1200	≥500	0	1500	0
	87	103	20	31	84	55	87	103	60	47	≥20	0	59	0
ATV6000C163A6666...	2360	2754	500	930	2130	1500	2210	2618	1530	1200	≥500	0	1500	0
	93	108	20	37	84	59	87	103	60	47	≥20	0	59	0
ATV6000C179A6666...	2360	2754	500	930	2130	1500	2210	2645	1830	1200	≥500	0	1500	0
	93	108	20	37	84	59	87	104	72	47	≥20	0	59	0
ATV6000C200A6666...	2360	2754	500	930	2430	1500	2210	2540	2230	1200	≥500	0	1500	0
	93	108	20	37	96	59	87	100	88	47	≥20	0	59	0
ATV6000C225A6666...	2360	2754	500	930	2430	1500	2210	2540	2230	1200	≥500	0	1500	0
	93	108	20	37	96	59	87	100	88	47	≥20	0	59	0
ATV6000C263A6666...	2360	2754	500	930	2430	1600	2210	2618	2230	1200	≥500	0	1500	0
	93	108	20	37	96	63	87	103	88	47	≥20	0	59	0
ATV6000C288A6666...	2360	2754	500	930	2430	1600	2210	2618	2230	1200	≥500	0	1500	0
	93	108	20	37	96	63	87	103	88	47	≥20	0	59	0
ATV6000C334A6666...	2360	2754	500	930	2730	1700	2210	2645	2430	1200	≥500	0	1500	0
	93	108	20	37	107	67	87	104	96	47	≥20	0	59	0
ATV6000C382A6666...	2360	2754	500	930	2730	1700	2360	2690	3230	1200	≥500	0	1500	0
	93	108	20	37	107	67	93	106	127	47	≥20	0	59	0
ATV6000C425A6666...	2360	2795	500	930	2730	1700	2360	2690	3230	1200	≥500	0	1500	0
	93	110	20	37	107	67	93	106	127	47	≥20	0	59	0
ATV6000C489A6666...	2360	2795	500	930	2730	1700	2360	2754	3230	1200	≥500	0	1500	0
	93	110	20	37	107	67	93	108	127	47	≥20	0	59	0
ATV6000C538A6666...	2360	2795	500	930	2730	1700	2360	2754	3230	1200	≥500	0	1500	0
	93	110	20	37	107	67	93	108	127	47	≥20	0	59	0
ATV6000C585A6666...	2720	3155	560	1290	3030	1800	2420	2828	3830	1200	≥500	0	1500	0
	107	124	22	51	119	71	95	111	151	47	≥20	0	59	0

Product reference	Transformer Cabinet (mm / in)						Power cell Cabinet (mm / in)				Space Maintenance (mm / in)			
	H1	H2	H3	H4	W1	D1	H5	H6	W2	D2	T	B (a)	F (b)	S(c)
ATV6000C657A6666...	2720	3155	560	1290	3330	1800	2420	2828	4630	1400	≥500	0	1500	0
	107	124	22	51	131	71	95	111	182	55	≥20	0	59	0
ATV6000C713A6666...	2720	3155	560	1290	3330	1800	2420	2828	4630	1400	≥500	0	1500	0
	107	124	22	51	131	71	95	111	182	55	≥20	0	59	0
ATV6000C775A6666...	2720	3155	560	1290	3630	1800	2420	2828	4630	1400	≥500	0	1500	0
	107	124	22	51	143	71	95	111	182	55	≥20	0	59	0
ATV6000C860A6666...	2720	3155	560	1290	3630	1800	2420	2855	4630	1400	≥500	0	1500	0
	107	124	22	51	143	71	95	112	182	55	≥20	0	59	0
ATV6000C925A6666...	2720	3155	560	1290	3630	1800	2420	2855	4630	1400	≥500	0	1500	0
	107	124	22	51	143	71	95	112	182	55	≥20	0	59	0
ATV6000- M102A6666...	2720	3155	560	1290	3630	1800	2420	2855	4630	1600	≥500	0	1500	0
	107	124	22	51	143	71	95	112	182	63	≥20	0	59	0
ATV6000M110A6666...	2720	3155	560	1290	3630	1800	2420	2855	4630	1600	≥500	≥600	1500	0
	107	124	22	51	143	71	95	112	182	63	≥20	≥24	59	0
ATV6000- M120A6666...	2720	3155	560	1290	3630	1800	2420	2855	5430	1600	≥500	≥600	1500	0
	107	124	22	51	143	71	95	112	214	63	≥20	≥24	59	0

a) Space could be required for installation and lifting lugs.
b) For easy handling with power cell exchange tool 2000mm (78.7 in) are recommended.
c) Space (600mm) could be required for maintenance of the front & rear access drive.

Output Voltage 10 kV

ATV6000D450A1010...ATV6000D790A1010

ATV6000	D450A1010NA●		D500A1010NA●	
	Normal Duty	Heavy Duty	Normal Duty	Heavy Duty
Nominal data				
Type rating [kVA]	450		500	
Max. Motor power [kW] / [HP] 1)	355/476	330/442	400/536	370/496
Nominal Continuous output current [A] 1)	24.5	23	27.6	26
Max. output current with 120 %overload 1 min / 10 min [A]	29.4	/	33.1	/
Max. output current with 150 % overload1 min / 10 min [A]	/	34.5	/	39
Power cells				
Number of cells per phase	8		8	
Power cell rated current [A]	35		35	
Power cell current with 120 %overload 1 min / 10 min [A]	42		42	
Max. output current for 3 sec [A]	52.5		52.5	
Characteristics with standard efficiency				
Efficiency at 100 % load (incl. Transformer) [%]	96.0%		96.0%	
Total losses at 100 % load [kW]	15.5	14.4	17.5	16.2
Air flow [m³/h]	12310		12310	
Noise level [dB (A)] @ 50 Hz	80		80	
Weight [kg / lb]	3896/8571		3958/8708	
Dimension [mm / inch] W*D*H 2)	3760*1600*2754/ 148.2*63.1*108.6		3760*1600*2754/ 148.2*63.1*108.6	
Connection				
Incoming cable type	symmetrical three-phase		symmetrical three-phase	
Typical cable size (mm² / AWG) 3)	95/000		95/000	
Motor cable type	symmetrical three-phase(Use of shielded cable is advisable)		symmetrical three-phase(Use of shielded cable is advisable)	
Typical cable size (mm² / AWG) 3)	25/4		25/4	
Motor cable Max. length 4)	1000 m		1000 m	
Grounding connection PE (mm² / AWG)	50/0		50/0	
Control power supply	single phase, 230V, 50/60Hz,		single phase, 230V, 50/60Hz,	
Capacity of control power supply w/o options	1 kVA		1 kVA	
Capacity of control power supply with options	"depending on options to be used"		"depending on options to be used"	
Fan power supply	3-phase 400 Vac, 50Hz		3-phase 400 Vac, 50Hz	
Capacity of fan power supply (kVA) 5)	5		5	
Maintenance				
Maintenance access	Front		Front	
Cable entry 6)	Bottom in /Bottom out		Bottom in /Bottom out	

ATV6000	D630A1010NA●		D700A1010NA●	
	Normal Duty	Heavy Duty	Normal Duty	Heavy Duty
Nominal data				
Type rating [kVA]	630		700	
Max. Motor power [kW] / [HP] 1)	500/670	400/536	560/750	530/710
Nominal Continuous output current [A] 1)	35	28	38.7	37
Max. output current with 120 %overload 1 min / 10 min [A]	42	/	46.4	/
Max. output current with 150 % overload1 min / 10 min [A]	/	42	/	55.5
Power cells				
Number of cells per phase	8		8	
Power cell rated current [A]	35		65	
Power cell current with 120 %overload 1 min / 10 min [A]	42		78	
Max. output current for 3 sec [A]	52.5		97.5	
Characteristics with standard efficiency				
Efficiency at 100 % load (incl. Transformer) [%]	96.0%		96.0%	
Total losses at 100 % load [kW]	21.9	17.5	24.4	23.1
Air flow [m ³ /h]	12310		12310	
Noise level [dB (A)] @ 50 Hz	80		80	
Weight [kg / lb]	4119/9062		4206/9253	
Dimension [mm / inch] W*D*H 2)	3760*1600*2754/ 148.2*63.1*108.6		3760*1600*2754/ 148.2*63.1*108.6	
Connection				
Incoming cable type	symmetrical three-phase		symmetrical three-phase	
Typical cable size (mm ² / AWG) 3)	95/000		95/000	
Motor cable type	symmetrical three-phase(Use of shielded cable is advisable)		symmetrical three-phase(Use of shielded cable is advisable)	
Typical cable size (mm ² / AWG) 3)	25/4		25/4	
Motor cable Max. length 4)	1000 m		1000 m	
Grounding connection PE (mm ² / AWG)	50/0		50/0	
Control power supply	single phase, 230V, 50/60Hz,		single phase, 230V, 50/60Hz,	
Capacity of control power supply w/o options	1 kVA		1 kVA	
Capacity of control power supply with options	"depending on options to be used"		"depending on options to be used"	
Fan power supply	3-phase 400 Vac, 50Hz		3-phase 400 Vac, 50Hz	
Capacity of fan power supply (kVA) 5)	5		5	
Maintenance				
Maintenance access	Front		Front	
Cable entry 6)	Bottom in /Bottom out		Bottom in /Bottom out	

ATV6000	D790A1010NA●	
Nominal data	Normal Duty	Heavy Duty
Type rating [kVA]	790	
Max. Motor power [kW] / [HP] 1)	630/844	590/791
Nominal Continuous output current [A] 1)	43.5	41
Max. output current with 120 %overload 1 min / 10 min [A]	52.2	/
Max. output current with 150 % overload 1 min / 10 min [A]	/	61.5
Power cells		
Number of cells per phase	8	
Power cell rated current [A]	65	
Power cell current with 120 %overload 1 min / 10 min [A]	78	
Max. output current for 3 sec [A]	97.5	
Characteristics with standard efficiency		
Efficiency at 100 % load (incl. Transformer) [%]	96.0%	
Total losses at 100 % load [kW]	27.4	25.7
Air flow [m³/h]	12310	
Noise level [dB (A)] @ 50 Hz	80	
Weight [kg / lb]	4317/9497	
Dimension [mm / inch] W*D*H 2)	3760*1600*2754/148.2*63.1*108.6	
Connection		
Incoming cable type	symmetrical three-phase	
Typical cable size (mm² / AWG) 3)	95/000	
Motor cable type	symmetrical three-phase(Use of shielded cable is advisable)	
Typical cable size (mm² / AWG) 3)	25/4	
Motor cable Max. length 4)	1000 m	
Grounding connection PE (mm² / AWG)	50/0	
Control power supply	single phase, 230V, 50/60Hz,	
Capacity of control power supply w/o options	1 kVA	
Capacity of control power supply with options	"depending on options to be used"	
Fan power supply	3-phase 400 Vac, 50Hz	
Capacity of fan power supply (kVA) 5)	5	
Maintenance		
Maintenance access	Front	
Cable entry 6)	Bottom in /Bottom out	
1) Values valid for synchronous motor and asynchronous motor. The specifications for the maximum motor shaft power is based on a motor efficiency of 95%. 2) Including the height of top cooling fans. 3) For CE products: Typical cable size values based on use of copper cables in cable tray laying. Incoming cable size is based on drive current rating. It has to be checked to be in accordance to mains short circuit capability and local and national electrical code requirement as well all other applicable regulations. 4) Variation in max. cable length may be possible depending on type cable and installation. For longer cable length between motor and drive contact Schneider Electric. 5) Contact Schneider Electric if N+1 redundancy cooling fan requested. 6) For other combination contact Schneider Electric.		

ATV6000D890A1010...ATV6000C138A1010

ATV6000	D890A1010NA●		C100A1010NA●	
Nominal data	Normal Duty	Heavy Duty	Normal Duty	Heavy Duty
Type rating [kVA]	890		1000	
Max. Motor power [kW] / [HP] 1)	710/952	680/911	800/1072	750/1005
Nominal Continuous output current [A] 1)	49	47	55.2	52
Max. output current with 120 %overload 1 min / 10 min [A]	58.8	/	66.2	/
Max. output current with 150 % overload1 min / 10 min [A]	/	70.5	/	78
Power cells				
Number of cells per phase	8		8	
Power cell rated current [A]	65		65	
Power cell current with 120 %overload 1 min / 10 min [A]	78		78	
Max. output current for 3 sec [A]	97.5		97.5	
Characteristics with standard efficiency				
Efficiency at 100 % load (incl. Transformer) [%]	96.0%		96.0%	
Total losses at 100 % load [kW]	30.9	29.7	34.9	32.7
Air flow [m ³ /h]	15130		15130	
Noise level [dB (A)] @ 50 Hz	80		80	
Weight [kg / lb]	4568/10050		4705/10351	
Dimension [mm / inch] W*D*H 2)	4060*1600*2754/ 160*63.1*108.6		4060*1600*2754/ 160*63.1*108.6	
Connection				
Incoming cable type	symmetrical three-phase		symmetrical three-phase	
Typical cable size (mm ² / AWG) 3)	95/000		95/000	
Motor cable type	symmetrical three-phase(Use of shielded cable is advisable)		symmetrical three-phase(Use of shielded cable is advisable)	
Typical cable size (mm ² / AWG) 3)	25/4		25/4	
Motor cable Max. length 4)	1000 m		1000 m	
Grounding connection PE (mm ² / AWG)	50/0		50/0	
Control power supply	single phase, 230V, 50/60Hz,		single phase, 230V, 50/60Hz,	
Capacity of control power supply w/o options	1 kVA		1 kVA	
Capacity of control power supply with options	"depending on options to be used"		"depending on options to be used"	
Fan power supply	3-phase 400 Vac, 50Hz		3-phase 400 Vac, 50Hz	
Capacity of fan power supply (kVA) 5)	7		7	
Maintenance				
Maintenance access	Front		Front	
Cable entry 6)	Bottom in /Bottom out		Bottom in /Bottom out	

ATV6000	C118A1010NA●		C138A1010NA●	
Nominal data	Normal Duty	Heavy Duty	Normal Duty	Heavy Duty
Type rating [kVA]	1180		1380	
Max. Motor power [kW] / [HP] 1)	940/1260	750/1005	1100/1475	1050/1408
Nominal Continuous output current [A] 1)	65	52	76	73
Max. output current with 120 %overload 1 min / 10 min [A]	78	/	91.2	/
Max. output current with 150 % overload 1 min / 10 min [A]	/	78	/	110
Power cells				
Number of cells per phase	8		8	
Power cell rated current [A]	65		100	
Power cell current with 120 %overload 1 min / 10 min [A]	78		120	
Max. output current for 3 sec [A]	97.5		150	
Characteristics with standard efficiency				
Efficiency at 100 % load (incl. Transformer) [%]	96.0%		96.0%	
Total losses at 100 % load [kW]	40.9	32.7	47.9	45.7
Air flow [m³/h]	15130		15130	
Noise level [dB (A)] @ 50 Hz	80		80	
Weight [kg / lb]	4927/10839		5175/11385	
Dimension [mm / inch] W*D*H 2)	4060*1600*2754/ 160*63.1*108.6		4060*1600*2754/ 160*63.1*108.6	
Connection				
Incoming cable type	symmetrical three-phase		symmetrical three-phase	
Typical cable size (mm² / AWG) 3)	95/000		95/000	
Motor cable type	symmetrical three-phase(Use of shielded cable is advisable)		symmetrical three-phase(Use of shielded cable is advisable)	
Typical cable size (mm² / AWG) 3)	25/4		25/4	
Motor cable Max. length 4)	1000 m		1000 m	
Grounding connection PE (mm² / AWG)	50/0		50/0	
Control power supply	single phase, 230V, 50/60Hz,		single phase, 230V, 50/60Hz,	
Capacity of control power supply w/o options	1 kVA		1 kVA	
Capacity of control power supply with options	"depending on options to be used"		"depending on options to be used"	
Fan power supply	3-phase 400 Vac, 50Hz		3-phase 400 Vac, 50Hz	
Capacity of fan power supply (kVA) 5)	7		7	
Maintenance				
Maintenance access	Front		Front	
Cable entry 6)	Bottom in /Bottom out		Bottom in /Bottom out	
1) Values valid for synchronous motor and asynchronous motor. The specifications for the maximum motor shaft power is based on a motor efficiency of 95%. 2) Including the height of top cooling fans. 3) For CE products: Typical cable size values based on use of copper cables in cable tray laying. Incoming cable size is based on drive current rating. It has to be checked to be in accordance to mains short circuit capability and local and national electrical code requirement as well all other applicable regulations. 4) Variation in max. cable length may be possible depending on type cable and installation. For longer cable length between motor and drive contact Schneider Electric. 5) Contact Schneider Electric if N+1 redundancy cooling fan requested. 6) For other combination contact Schneider Electric.				

ATV6000C150A1010...ATV6000C180A1010

ATV6000	C150A1010NA●		C180A1010NA●	
Nominal data	Normal Duty	Heavy Duty	Normal Duty	Heavy Duty
Type rating [kVA]	1500		1800	
Max. Motor power [kW] / [HP] 1)	1200/1609	1140/1528	1440/1931	1150/1542
Nominal Continuous output current [A] 1)	82.9	79	100	80
Max. output current with 120 %overload 1 min / 10 min [A]	99.4	/	120	/
Max. output current with 150 % overload 1 min / 10 min [A]	/	119	/	120
Power cells				
Number of cells per phase	8		8	
Power cell rated current [A]	100		100	
Power cell current with 120 %overload 1 min / 10 min [A]	120		120	
Max. output current for 3 sec [A]	150		150	
Characteristics with standard efficiency				
Efficiency at 100 % load (incl. Transformer) [%]	96.0%		96.0%	
Total losses at 100 % load [kW]	52.2	49.6	62.6	50.1
Air flow [m ³ /h]	15130		15130	
Noise level [dB (A)] @ 50 Hz	80		80	
Weight [kg / lb]	5356/11783		5728/12602	
Dimension [mm / inch] W*D*H 2)	4060*1700*2754/160*67*108.6		4060*1700*2754/160*67*108.6	
Connection				
Incoming cable type	symmetrical three-phase		symmetrical three-phase	
Typical cable size (mm ² / AWG) 3)	95/000		95/000	
Motor cable type	symmetrical three-phase(Use of shielded cable is advisable)		symmetrical three-phase(Use of shielded cable is advisable)	
Typical cable size (mm ² / AWG) 3)	25/4		25/4	
Motor cable Max. length 4)	1000 m		1000 m	
Grounding connection PE (mm ² / AWG)	50/0		50/0	
Control power supply	single phase, 230V, 50/60Hz,		single phase, 230V, 50/60Hz,	
Capacity of control power supply w/o options	1 kVA		1 kVA	
Capacity of control power supply with options	"depending on options to be used"		"depending on options to be used"	
Fan power supply	3-phase 400 Vac, 50Hz		3-phase 400 Vac, 50Hz	
Capacity of fan power supply (kVA) 5)	7		7	
Maintenance				
Maintenance access	Front		Front	
Cable entry 6)	Bottom in /Bottom out		Bottom in /Bottom out	
<p>1) Values valid for synchronous motor and asynchronous motor. The specifications for the maximum motor shaft power is based on a motor efficiency of 95%.</p> <p>2) Including the height of top cooling fans.</p> <p>3) For CE products: Typical cable size values based on use of copper cables in cable tray laying. Incoming cable size is based on drive current rating. It has to be checked to be in accordance to mains short circuit capability and local and national electrical code requirement as well all other applicable regulations.</p> <p>4) Variation in max. cable length may be possible depending on type cable and installation. For longer cable length between motor and drive contact Schneider Electric.</p> <p>5) Contact Schneider Electric if N+1 redundancy cooling fan requested.</p> <p>6) For other combination contact Schneider Electric.</p>				

ATV6000C200A1010...ATV6000C225A1010

ATV6000	C200A1010NA●		C225A1010NA●	
Nominal data	Normal Duty	Heavy Duty	Normal Duty	Heavy Duty
Type rating [kVA]	2000		2250	
Max. Motor power [kW] / [HP] 1)	1600/2145	1530/2051	1800/2413	1720/2306
Nominal Continuous output current [A] 1)	111	106	124	119
Max. output current with 120 %overload 1 min / 10 min [A]	133	/	149	/
Max. output current with 150 % overload 1 min / 10 min [A]	/	159	/	179
Power cells				
Number of cells per phase	8		8	
Power cell rated current [A]	150		150	
Power cell current with 120 %overload 1 min / 10 min [A]	180		180	
Max. output current for 3 sec [A]	225		225	
Characteristics with standard efficiency				
Efficiency at 100 % load (incl. Transformer) [%]	96.0%		96.0%	
Total losses at 100 % load [kW]	69.6	66.6	78.3	74.8
Air flow [m³/h]	26160		26160	
Noise level [dB (A)] @ 50 Hz	83		83	
Weight [kg / lb]	6993/15385		7302/16064	
Dimension [mm / inch] W*D*H 2)	5060*1700*2795/ 199.4*67*110.2		5060*1700*2795/ 199.4*67*110.2	
Connection				
Incoming cable type	symmetrical three-phase		symmetrical three-phase	
Typical cable size (mm² / AWG) 3)	95/000		95/000	
Motor cable type	symmetrical three-phase(Use of shielded cable is advisable)		symmetrical three-phase(Use of shielded cable is advisable)	
Typical cable size (mm² / AWG) 3)	35/2		35/2	
Motor cable Max. length 4)	1000 m		1000 m	
Grounding connection PE (mm² / AWG)	50/0		50/0	
Control power supply	single phase, 230V, 50/60Hz,		single phase, 230V, 50/60Hz,	
Capacity of control power supply w/o options	1 kVA		1 kVA	
Capacity of control power supply with options	"depending on options to be used"		"depending on options to be used"	
Fan power supply	3-phase 400 Vac, 50Hz		3-phase 400 Vac, 50Hz	
Capacity of fan power supply (kVA) 5)	19		19	
Maintenance				
Maintenance access	Front		Front	
Cable entry 6)	Bottom in /Bottom out		Bottom in /Bottom out	
1) Values valid for synchronous motor and asynchronous motor. The specifications for the maximum motor shaft power is based on a motor efficiency of 95%. 2) Including the height of top cooling fans. 3) For CE products: Typical cable size values based on use of copper cables in cable tray laying. Incoming cable size is based on drive current rating. It has to be checked to be in accordance to mains short circuit capability and local and national electrical code requirement as well all other applicable regulations. 4) Variation in max. cable length may be possible depending on type cable and installation. For longer cable length between motor and drive contact Schneider Electric. 5) Contact Schneider Electric if N+1 redundancy cooling fan requested. 6) For other combination contact Schneider Electric.				

ATV6000C272A1010

ATV6000	C272A1010NA●	
Nominal data	Normal Duty	Heavy Duty
Type rating [kVA]	2720	
Max. Motor power [kW] / [HP] 1)	2170/2910	1730/2319
Nominal Continuous output current [A] 1)	150	120
Max. output current with 120 %overload 1 min / 10 min [A]	180	/
Max. output current with 150 % overload 1 min / 10 min [A]	/	180
Power cells		
Number of cells per phase	8	
Power cell rated current [A]	150	
Power cell current with 120 %overload 1 min / 10 min [A]	180	
Max. output current for 3 sec [A]	225	
Characteristics with standard efficiency		
Efficiency at 100 % load (incl. Transformer) [%]	96.0%	
Total losses at 100 % load [kW]	94.3	75.3
Air flow [m ³ /h]	26880	
Noise level [dB (A)] @ 50 Hz	83	
Weight [kg / lb]	8096/17811	
Dimension [mm / inch] W*D*H 2)	5360*1700*2795/211.2*67*110.2	
Connection		
Incoming cable type	symmetrical three-phase	
Typical cable size (mm ² / AWG) 3)	95/000	
Motor cable type	symmetrical three-phase(Use of shielded cable is advisable)	
Typical cable size (mm ² / AWG) 3)	35/2	
Motor cable Max. length 4)	1000 m	
Grounding connection PE (mm ² / AWG)	50/0	
Control power supply	single phase, 230V, 50/60Hz,	
Capacity of control power supply w/o options	1 kVA	
Capacity of control power supply with options	"depending on options to be used"	
Fan power supply	3-phase 400 Vac, 50Hz	
Capacity of fan power supply (kVA) 5)	19	
Maintenance		
Maintenance access	Front	
Cable entry 6)	Bottom in /Bottom out	
<p>1) Values valid for synchronous motor and asynchronous motor. The specifications for the maximum motor shaft power is based on a motor efficiency of 95%.</p> <p>2) Including the height of top cooling fans.</p> <p>3) For CE products: Typical cable size values based on use of copper cables in cable tray laying. Incoming cable size is based on drive current rating. It has to be checked to be in accordance to mains short circuit capability and local and national electrical code requirement as well all other applicable regulations.</p> <p>4) Variation in max. cable length may be possible depending on type cable and installation. For longer cable length between motor and drive contact Schneider Electric.</p> <p>5) Contact Schneider Electric if N+1 redundancy cooling fan requested.</p> <p>6) For other combination contact Schneider Electric.</p>		

ATV6000C300A1010...ATV6000C350A1010

ATV6000	C300A1010NA●		C325A1010NA●	
Nominal data	Normal Duty	Heavy Duty	Normal Duty	Heavy Duty
Type rating [kVA]	3000		3250	
Max. Motor power [kW] / [HP] 1)	2400/3218	2300/3084	2600/3486	2310/3097
Nominal Continuous output current [A] 1)	166	159	180	160
Max. output current with 120 %overload 1 min / 10 min [A]	199	/	216	/
Max. output current with 150 % overload1 min / 10 min [A]	/	239	/	240
Power cells				
Number of cells per phase	8		8	
Power cell rated current [A]	200		200	
Power cell current with 120 %overload 1 min / 10 min [A]	240		240	
Max. output current for 3 sec [A]	300		300	
Characteristics with standard efficiency				
Efficiency at 100 % load (incl. Transformer) [%]	96.0%		96.0%	
Total losses at 100 % load [kW]	104.3	100.0	113.0	100.4
Air flow [m³/h]	24077		24077	
Noise level [dB (A)] @ 50 Hz	80		80	
Weight [kg / lb]	9076/19967		9385/20647	
Dimension [mm / inch] W*D*H 2)	6160*1700*2754/ 242.8*67*108.6		6160*1700*2754/ 242.8*67*108.6	
Connection				
Incoming cable type	symmetrical three-phase		symmetrical three-phase	
Typical cable size (mm² / AWG) 3)	95/000		95/000	
Motor cable type	symmetrical three-phase(Use of shielded cable is advisable)		symmetrical three-phase(Use of shielded cable is advisable)	
Typical cable size (mm² / AWG) 3)	35/2		50/0	
Motor cable Max. length 4)	1000 m		1000 m	
Grounding connection PE (mm² / AWG)	50/0		50/0	
Control power supply	single phase, 230V, 50/60Hz,		single phase, 230V, 50/60Hz,	
Capacity of control power supply w/o options	1 kVA		1 kVA	
Capacity of control power supply with options	"depending on options to be used"		"depending on options to be used"	
Fan power supply	3-phase 400 Vac, 50Hz		3-phase 400 Vac, 50Hz	
Capacity of fan power supply (kVA) 5)	9		9	
Maintenance				
Maintenance access	Front		Front	
Cable entry 6)	Bottom in /Bottom out		Bottom in /Bottom out	

ATV6000	C350A1010NA●	
Nominal data	Normal Duty	Heavy Duty
Type rating [kVA]	3500	
Max. Motor power [kW] / [HP] 1)	2800/3754	2310/3097
Nominal Continuous output current [A] 1)	193	160
Max. output current with 120 %overload 1 min / 10 min [A]	232	/
Max. output current with 150 % overload1 min / 10 min [A]	/	240
Power cells		
Number of cells per phase	8	
Power cell rated current [A]	200	
Power cell current with 120 %overload 1 min / 10 min [A]	240	
Max. output current for 3 sec [A]	300	
Characteristics with standard efficiency		
Efficiency at 100 % load (incl. Transformer) [%]	96.0%	
Total losses at 100 % load [kW]	121.7	100.4
Air flow [m ³ /h]	24077	
Noise level [dB (A)] @ 50 Hz	83	
Weight [kg / lb]	9695/21329	
Dimension [mm / inch] W*D*H 2)	6160*1700*2754/242.8*67*108.6	
Connection		
Incoming cable type	symmetrical three-phase	
Typical cable size (mm ² / AWG) 3)	95/000	
Motor cable type	symmetrical three-phase(Use of shielded cable is advisable)	
Typical cable size (mm ² / AWG) 3)	50/0	
Motor cable Max. length 4)	1000 m	
Grounding connection PE (mm ² / AWG)	50/0	
Control power supply	single phase, 230V, 50/60Hz,	
Capacity of control power supply w/o options	1 kVA	
Capacity of control power supply with options	"depending on options to be used"	
Fan power supply	3-phase 400 Vac, 50Hz	
Capacity of fan power supply (kVA) 5)	9	
Maintenance		
Maintenance access	Front	
Cable entry 6)	Bottom in /Bottom out	
<p>1) Values valid for synchronous motor and asynchronous motor. The specifications for the maximum motor shaft power is based on a motor efficiency of 95%.</p> <p>2) Including the height of top cooling fans.</p> <p>3) For CE products: Typical cable size values based on use of copper cables in cable tray laying. Incoming cable size is based on drive current rating. It has to be checked to be in accordance to mains short circuit capability and local and national electrical code requirement as well all other applicable regulations.</p> <p>4) Variation in max. cable length may be possible depending on type cable and installation. For longer cable length between motor and drive contact Schneider Electric.</p> <p>5) Contact Schneider Electric if N+1 redundancy cooling fan requested.</p> <p>6) For other combination contact Schneider Electric.</p>		

ATV6000C398A1010...ATV6000C438A1010

ATV6000	C398A1010NA●		C438A1010NA●	
Nominal data	Normal Duty	Heavy Duty	Normal Duty	Heavy Duty
Type rating [kVA]	3980		4380	
Max. Motor power [kW] / [HP] 1)	3180/4264	2540/3406	3500/4693	3240/4344
Nominal Continuous output current [A] 1)	220	176	242	224
Max. output current with 120 %overload 1 min / 10 min [A]	264	/	290	/
Max. output current with 150 % overload 1 min / 10 min [A]	/	264	/	336
Power cells				
Number of cells per phase	8		8	
Power cell rated current [A]	220		280	
Power cell current with 120 %overload 1 min / 10 min [A]	264		336	
Max. output current for 3 sec [A]	330		420	
Characteristics with standard efficiency				
Efficiency at 100 % load (incl. Transformer) [%]	96.0%		96.0%	
Total losses at 100 % load [kW]	138.2	110.5	152.2	140.8
Air flow [m³/h]	33282		43650	
Noise level [dB (A)] @ 50 Hz	83		85	
Weight [kg / lb]	10823/23811		11457/25205	
Dimension [mm / inch] W*D*H 2)	6460*1800*3155/ 254.6*71*124.4		6460*1800*3155/ 254.6*71*124.4	
Connection				
Incoming cable type	symmetrical three-phase		symmetrical three-phase	
Typical cable size (mm² / AWG) 3)	95/000		95/000	
Motor cable type	symmetrical three-phase(Use of shielded cable is advisable)		symmetrical three-phase(Use of shielded cable is advisable)	
Typical cable size (mm² / AWG) 3)	70/00		70/00	
Motor cable Max. length 4)	1000 m		1000 m	
Grounding connection PE (mm² / AWG)	50/0		50/0	
Control power supply	single phase, 230V, 50/60Hz,		single phase, 230V, 50/60Hz,	
Capacity of control power supply w/o options	1 kVA		1 kVA	
Capacity of control power supply with options	"depending on options to be used"		"depending on options to be used"	
Fan power supply	3-phase 400 Vac, 50Hz		3-phase 400 Vac, 50Hz	
Capacity of fan power supply (kVA) 5)	19		34	
Maintenance				
Maintenance access	Front		Front	
Cable entry 6)	Bottom in /Bottom out		Bottom in /Bottom out	
1) Values valid for synchronous motor and asynchronous motor. The specifications for the maximum motor shaft power is based on a motor efficiency of 95%. 2) Including the height of top cooling fans. 3) For CE products: Typical cable size values based on use of copper cables in cable tray laying. Incoming cable size is based on drive current rating. It has to be checked to be in accordance to mains short circuit capability and local and national electrical code requirement as well all other applicable regulations. 4) Variation in max. cable length may be possible depending on type cable and installation. For longer cable length between motor and drive contact Schneider Electric. 5) Contact Schneider Electric if N+1 redundancy cooling fan requested. 6) For other combination contact Schneider Electric.				

ATV6000C507A1010

ATV6000	C507A1010NA●	
Nominal data	Normal Duty	Heavy Duty
Type rating [kVA]	5070	
Max. Motor power [kW] / [HP] 1)	4050/5431	3240/4344
Nominal Continuous output current [A] 1)	280	224
Max. output current with 120 %overload 1 min / 10 min [A]	336	/
Max. output current with 150 % overload 1 min / 10 min [A]	/	336
Power cells		
Number of cells per phase	8	
Power cell rated current [A]	280	
Power cell current with 120 %overload 1 min / 10 min [A]	336	
Max. output current for 3 sec [A]	420	
Characteristics with standard efficiency		
Efficiency at 100 % load (incl. Transformer) [%]	96.5%	
Total losses at 100 % load [kW]	153.4	122.7
Air flow [m ³ /h]	46565	
Noise level [dB (A)] @ 50 Hz	85	
Weight [kg / lb]	12426/27337	
Dimension [mm / inch] W*D*H 2)	6760*1800*3155/266.4*71*124.4	
Connection		
Incoming cable type	symmetrical three-phase	
Typical cable size (mm ² / AWG) 3)	95/000	
Motor cable type	symmetrical three-phase(Use of shielded cable is advisable)	
Typical cable size (mm ² / AWG) 3)	95/000	
Motor cable Max. length 4)	1000 m	
Grounding connection PE (mm ² / AWG)	50/0	
Control power supply	single phase, 230V, 50/60Hz,	
Capacity of control power supply w/o options	1 kVA	
Capacity of control power supply with options	"depending on options to be used"	
Fan power supply	3-phase 400 Vac, 50Hz	
Capacity of fan power supply (kVA) 5)	34	
Maintenance		
Maintenance access	Front & Rear	
Cable entry 6)	Bottom in /Bottom out	
<p>1) Values valid for synchronous motor and asynchronous motor. The specifications for the maximum motor shaft power is based on a motor efficiency of 95%.</p> <p>2) Including the height of top cooling fans.</p> <p>3) For CE products: Typical cable size values based on use of copper cables in cable tray laying. Incoming cable size is based on drive current rating. It has to be checked to be in accordance to mains short circuit capability and local and national electrical code requirement as well all other applicable regulations.</p> <p>4) Variation in max. cable length may be possible depending on type cable and installation. For longer cable length between motor and drive contact Schneider Electric.</p> <p>5) Contact Schneider Electric if N+1 redundancy cooling fan requested.</p> <p>6) For other combination contact Schneider Electric.</p>		

ATV6000C538A1010...ATV6000C625A1010

ATV6000	C538A1010NA●		C579A1010NA●	
Nominal data	Normal Duty	Heavy Duty	Normal Duty	Heavy Duty
Type rating [kVA]	5380		5790	
Max. Motor power [kW] / [HP] 1)	4300/5766	3700/4961	4630/6208	3700/4961
Nominal Continuous output current [A] 1)	297	256	320	256
Max. output current with 120 %overload 1 min / 10 min [A]	356	/	384	/
Max. output current with 150 % overload 1 min / 10 min [A]	/	384	/	384
Power cells				
Number of cells per phase	8		8	
Power cell rated current [A]	320		320	
Power cell current with 120 %overload 1 min / 10 min [A]	384		384	
Max. output current for 3 sec [A]	480		480	
Characteristics with standard efficiency				
Efficiency at 100 % load (incl. Transformer) [%]	96.5%		96.5%	
Total losses at 100 % load [kW]	162.8	140.1	175.3	140.1
Air flow [m³/h]	43896		43896	
Noise level [dB (A)] @ 50 Hz	83		83	
Weight [kg / lb]	15252/33554		15760/34672	
Dimension [mm / inch] W*D*H 2)	8560*1800*3155/ 337.3*71*124.4		8560*1800*3155/ 337.3*71*124.4	
Connection				
Incoming cable type	symmetrical three-phase		symmetrical three-phase	
Typical cable size (mm² / AWG) 3)	120/0000		120/0000	
Motor cable type	symmetrical three-phase(Use of shielded cable is advisable)		symmetrical three-phase(Use of shielded cable is advisable)	
Typical cable size (mm² / AWG) 3)	95/000		120/0000	
Motor cable Max. length 4)	1000 m		1000 m	
Grounding connection PE (mm² / AWG)	50/0		50/0	
Control power supply	single phase, 230V, 50/60Hz,		single phase, 230V, 50/60Hz,	
Capacity of control power supply w/o options	1 kVA		1 kVA	
Capacity of control power supply with options	"depending on options to be used"		"depending on options to be used"	
Fan power supply	3-phase 400 Vac, 50Hz		3-phase 400 Vac, 50Hz	
Capacity of fan power supply (kVA) 5)	23		23	
Maintenance				
Maintenance access	Front & Rear		Front & Rear	
Cable entry 6)	Bottom in /Bottom out		Bottom in /Bottom out	

ATV6000	C625A1010NA●	
Nominal data	Normal Duty	Heavy Duty
Type rating [kVA]	6250	
Max. Motor power [kW] / [HP] 1)	5000/6705	4740/6356
Nominal Continuous output current [A] 1)	345	328
Max. output current with 120 %overload 1 min / 10 min [A]	414	/
Max. output current with 150 % overload1 min / 10 min [A]	/	492
Power cells		
Number of cells per phase	8	
Power cell rated current [A]	410	
Power cell current with 120 %overload 1 min / 10 min [A]	492	
Max. output current for 3 sec [A]	615	
Characteristics with standard efficiency		
Efficiency at 100 % load (incl. Transformer) [%]	96.5%	
Total losses at 100 % load [kW]	189.3	179.4
Air flow [m ³ /h]	43896	
Noise level [dB (A)] @ 50 Hz	83	
Weight [kg / lb]	16329/35924	
Dimension [mm / inch] W*D*H 2)	8560*1800*3155/337.3*71*124.4	
Connection		
Incoming cable type	symmetrical three-phase	
Typical cable size (mm ² / AWG) 3)	150/300MCM	
Motor cable type	symmetrical three-phase(Use of shielded cable is advisable)	
Typical cable size (mm ² / AWG) 3)	120/0000	
Motor cable Max. length 4)	1000 m	
Grounding connection PE (mm ² / AWG)	70/00	
Control power supply	single phase, 230V, 50/60Hz,	
Capacity of control power supply w/o options	1 kVA	
Capacity of control power supply with options	"depending on options to be used"	
Fan power supply	3-phase 400 Vac, 50Hz	
Capacity of fan power supply (kVA) 5)	23	
Maintenance		
Maintenance access	Front & Rear	
Cable entry 6)	Bottom in /Bottom out	
<p>1) Values valid for synchronous motor and asynchronous motor. The specifications for the maximum motor shaft power is based on a motor efficiency of 95%.</p> <p>2) Including the height of top cooling fans.</p> <p>3) For CE products: Typical cable size values based on use of copper cables in cable tray laying. Incoming cable size is based on drive current rating. It has to be checked to be in accordance to mains short circuit capability and local and national electrical code requirement as well all other applicable regulations.</p> <p>4) Variation in max. cable length may be possible depending on type cable and installation. For longer cable length between motor and drive contact Schneider Electric.</p> <p>5) Contact Schneider Electric if N+1 redundancy cooling fan requested.</p> <p>6) For other combination contact Schneider Electric.</p>		

ATV6000C742A1010...ATV6000C887A1010

ATV6000	C742A1010NA●		C813A1010NA●	
Nominal data	Normal Duty	Heavy Duty	Normal Duty	Heavy Duty
Type rating [kVA]	7420		8130	
Max. Motor power [kW] / [HP] 1)	5930/7952	4740/6356	6500/8716	5670/7603
Nominal Continuous output current [A] 1)	410	328	449	392
Max. output current with 120 %overload 1 min / 10 min [A]	492	/	539	/
Max. output current with 150 % overload1 min / 10 min [A]	/	492	/	588
Power cells				
Number of cells per phase	8		8	
Power cell rated current [A]	410		490	
Power cell current with 120 %overload 1 min / 10 min [A]	492		588	
Max. output current for 3 sec [A]	615		735	
Characteristics with standard efficiency				
Efficiency at 100 % load (incl. Transformer) [%]	96.5%		96.5%	
Total losses at 100 % load [kW]	224.5	179.4	246.0	214.6
Air flow [m³/h]	51587		53291	
Noise level [dB (A)] @ 50 Hz	83		85	
Weight [kg / lb]	17913/39409		18764/41281	
Dimension [mm / inch] W*D*H 2)	8860*1800*3155/ 349.1*71*124.4		8860*1800*3155/ 349.1*71*124.4	
Connection				
Incoming cable type	symmetrical three-phase		symmetrical three-phase	
Typical cable size (mm² / AWG) 3)	185/350MCM		240/500MCM	
Motor cable type	symmetrical three-phase(Use of shielded cable is advisable)		symmetrical three-phase(Use of shielded cable is advisable)	
Typical cable size (mm² / AWG) 3)	185/350MCM		240/500MCM	
Motor cable Max. length 4)	1000 m		1000 m	
Grounding connection PE (mm² / AWG)	70/00		95/000	
Control power supply	single phase, 230V, 50/60Hz,		single phase, 230V, 50/60Hz,	
Capacity of control power supply w/o options	1 kVA		1 kVA	
Capacity of control power supply with options	"depending on options to be used"		"depending on options to be used"	
Fan power supply	3-phase 400 Vac, 50Hz		3-phase 400 Vac, 50Hz	
Capacity of fan power supply (kVA) 5)	28		31	
Maintenance				
Maintenance access	Front & Rear		Front & Rear	
Cable entry 6)	Bottom in /Bottom out		Bottom in /Bottom out	

ATV6000	C887A1010NA●	
Nominal data	Normal Duty	Heavy Duty
Type rating [kVA]	8870	
Max. Motor power [kW] / [HP] 1)	7090/9507	5670/7603
Nominal Continuous output current [A] 1)	490	392
Max. output current with 120 %overload 1 min / 10 min [A]	588	/
Max. output current with 150 % overload1 min / 10 min [A]	/	588
Power cells		
Number of cells per phase	8	
Power cell rated current [A]	490	
Power cell current with 120 %overload 1 min / 10 min [A]	588	
Max. output current for 3 sec [A]	735	
Characteristics with standard efficiency		
Efficiency at 100 % load (incl. Transformer) [%]	96.5%	
Total losses at 100 % load [kW]	268.4	214.6
Air flow [m ³ /h]	53291	
Noise level [dB (A)] @ 50 Hz	85	
Weight [kg / lb]	19680/43296	
Dimension [mm / inch] W*D*H 2)	8860*1800*3155/349.1*71*124.4	
Connection		
Incoming cable type	symmetrical three-phase	
Typical cable size (mm ² / AWG) 3)	95*2/2*000	
Motor cable type	symmetrical three-phase(Use of shielded cable is advisable)	
Typical cable size (mm ² / AWG) 3)	240/500MCM	
Motor cable Max. length 4)	1000 m	
Grounding connection PE (mm ² / AWG)	95/000	
Control power supply	single phase, 230V, 50/60Hz,	
Capacity of control power supply w/o options	1 kVA	
Capacity of control power supply with options	"depending on options to be used"	
Fan power supply	3-phase 400 Vac, 50Hz	
Capacity of fan power supply (kVA) 5)	31	
Maintenance		
Maintenance access	Front & Rear	
Cable entry 6)	Bottom in /Bottom out	
<p>1) Values valid for synchronous motor and asynchronous motor. The specifications for the maximum motor shaft power is based on a motor efficiency of 95%.</p> <p>2) Including the height of top cooling fans.</p> <p>3) For CE products: Typical cable size values based on use of copper cables in cable tray laying. Incoming cable size is based on drive current rating. It has to be checked to be in accordance to mains short circuit capability and local and national electrical code requirement as well all other applicable regulations.</p> <p>4) Variation in max. cable length may be possible depending on type cable and installation. For longer cable length between motor and drive contact Schneider Electric.</p> <p>5) Contact Schneider Electric if N+1 redundancy cooling fan requested.</p> <p>6) For other combination contact Schneider Electric.</p>		

ATV6000C995A1010...ATV6000M107A1010

ATV6000	C995A1010NA●		M107A1010NA●	
Nominal data	Normal Duty	Heavy Duty	Normal Duty	Heavy Duty
Type rating [kVA]	9950		10700	
Max. Motor power [kW] / [HP] 1)	7960/10674	6370/8542	8500/11398	8160/10942
Nominal Continuous output current [A] 1)	550	440	587	564
Max. output current with 120 %overload 1 min / 10 min [A]	660	/	704	/
Max. output current with 150 % overload 1 min / 10 min [A]	/	660	/	846
Power cells				
Number of cells per phase	8		8	
Power cell rated current [A]	550		720	
Power cell current with 120 %overload 1 min / 10 min [A]	660		864	
Max. output current for 3 sec [A]	825		1080	
Characteristics with standard efficiency				
Efficiency at 100 % load (incl. Transformer) [%]	96.5%		96.5%	
Total losses at 100 % load [kW]	301.3	241.2	321.7	308.9
Air flow [m³/h]	83690		83690	
Noise level [dB (A)] @ 50 Hz	85		85	
Weight [kg / lb]	26051/57312		26979/59354	
Dimension [mm / inch] W*D*H 2)	13660*1800*3155/ 538.3*71*124.4		13660*1800*3155/ 538.3*71*124.4	
Connection				
Incoming cable type	symmetrical three-phase		symmetrical three-phase	
Typical cable size (mm² / AWG) 3)	95*2/2*000		120*2/2*0000	
Motor cable type	symmetrical three-phase(Use of shielded cable is advisable)		symmetrical three-phase(Use of shielded cable is advisable)	
Typical cable size (mm² / AWG) 3)	95*2/2*000		95*2/2*000	
Motor cable Max. length 4)	1000 m		1000 m	
Grounding connection PE (mm² / AWG)	95/000		120/0000	
Control power supply	single phase, 230V, 50/60Hz,		single phase, 230V, 50/60Hz,	
Capacity of control power supply w/o options	1 kVA		1 kVA	
Capacity of control power supply with options	"depending on options to be used"		"depending on options to be used"	
Fan power supply	3-phase 400 Vac, 50Hz		3-phase 400 Vac, 50Hz	
Capacity of fan power supply (kVA) 5)	57		57	
Maintenance				
Maintenance access	Front & Rear		Front & Rear	
Cable entry 6)	Bottom in /Bottom out		Bottom in /Bottom out	
1) Values valid for synchronous motor and asynchronous motor. The specifications for the maximum motor shaft power is based on a motor efficiency of 95%. 2) Including the height of top cooling fans. 3) For CE products: Typical cable size values based on use of copper cables in cable tray laying. Incoming cable size is based on drive current rating. It has to be checked to be in accordance to mains short circuit capability and local and national electrical code requirement as well all other applicable regulations. 4) Variation in max. cable length may be possible depending on type cable and installation. For longer cable length between motor and drive contact Schneider Electric. 5) Contact Schneider Electric if N+1 redundancy cooling fan requested. 6) For other combination contact Schneider Electric.				

ATV600M115A1010

ATV6000	M115A1010NA•	
Nominal data	Normal Duty	Heavy Duty
Type rating [kVA]	11500	
Max. Motor power [kW] / [HP] 1)	9200/12337	8340/11184
Nominal Continuous output current [A] 1)	635	576
Max. output current with 120 %overload 1 min / 10 min [A]	762	/
Max. output current with 150 % overload 1 min / 10 min [A]	/	864
Power cells		
Number of cells per phase	8	
Power cell rated current [A]	720	
Power cell current with 120 %overload 1 min / 10 min [A]	864	
Max. output current for 3 sec [A]	1080	
Characteristics with standard efficiency		
Efficiency at 100 % load (incl. Transformer) [%]	96.5%	
Total losses at 100 % load [kW]	348.2	315.6
Air flow [m ³ /h]	89520	
Noise level [dB (A)] @ 50 Hz	85	
Weight [kg / lb]	28199/62038	
Dimension [mm / inch] W*D*H 2)	14260*1800*3155/561.9*71*124.4	
Connection		
Incoming cable type	symmetrical three-phase	
Typical cable size (mm ² / AWG) 3)	120*2/2*0000	
Motor cable type	symmetrical three-phase(Use of shielded cable is advisable)	
Typical cable size (mm ² / AWG) 3)	120*2/2*0000	
Motor cable Max. length 4)	1000 m	
Grounding connection PE (mm ² / AWG)	120/0000	
Control power supply	single phase, 230V, 50/60Hz,	
Capacity of control power supply w/o options	1 kVA	
Capacity of control power supply with options	"depending on options to be used"	
Fan power supply	3-phase 400 Vac, 50Hz	
Capacity of fan power supply (kVA) 5)	57	
Maintenance		
Maintenance access	Front & Rear	
Cable entry 6)	Bottom in /Bottom out	
<p>1) Values valid for synchronous motor and asynchronous motor. The specifications for the maximum motor shaft power is based on a motor efficiency of 95%.</p> <p>2) Including the height of top cooling fans.</p> <p>3) For CE products: Typical cable size values based on use of copper cables in cable tray laying. Incoming cable size is based on drive current rating. It has to be checked to be in accordance to mains short circuit capability and local and national electrical code requirement as well all other applicable regulations.</p> <p>4) Variation in max. cable length may be possible depending on type cable and installation. For longer cable length between motor and drive contact Schneider Electric.</p> <p>5) Contact Schneider Electric if N+1 redundancy cooling fan requested.</p> <p>6) For other combination contact Schneider Electric.</p>		

ATV6000M131A1010...ATV6000M154A1010

ATV6000	M131A1010NA●		M143A1010NA●	
	Normal Duty	Heavy Duty	Normal Duty	Heavy Duty
Nominal data				
Type rating [kVA]	13100		14300	
Max. Motor power [kW] / [HP] 1)	10420/13973	8340/11184	11400/15287	9840/13195
Nominal Continuous output current [A] 1)	720	576	787	680
Max. output current with 120 %overload 1 min / 10 min [A]	864	/	945	/
Max. output current with 150 % overload 1 min / 10 min [A]	/	864	/	1020
Power cells				
Number of cells per phase	8		8	
Power cell rated current [A]	720		850	
Power cell current with 120 %overload 1 min / 10 min [A]	864		1020	
Max. output current for 3 sec [A]	1080		1275	
Characteristics with standard efficiency				
Efficiency at 100 % load (incl. Transformer) [%]	96.5%		96.5%	
Total losses at 100 % load [kW]	394.4	315.6	431.5	372.5
Air flow [m ³ /h]	104902		108166	
Noise level [dB (A)] @ 50 Hz	85		85	
Weight [kg / lb]	30450/66990		32101/70622	
Dimension [mm / inch] W*D*H 2)	14860*1800*3155/ 585.5*71*124.4		14860*1800*3155/ 585.5*71*124.4	
Connection				
Incoming cable type	symmetrical three-phase		symmetrical three-phase	
Typical cable size (mm ² / AWG) 3)	150*2/2*300MCM		185*2/2*350MCM	
Motor cable type	symmetrical three-phase(Use of shielded cable is advisable)		symmetrical three-phase(Use of shielded cable is advisable)	
Typical cable size (mm ² / AWG) 3)	150*2/2*300MCM		240*2/2*500MCM	
Motor cable Max. length 4)	1000 m		1000 m	
Grounding connection PE (mm ² / AWG)	120/0000		150/300MCM	
Control power supply	single phase, 230V, 50/60Hz,		single phase, 230V, 50/60Hz,	
Capacity of control power supply w/o options	1 kVA		1 kVA	
Capacity of control power supply with options	"depending on options to be used"		"depending on options to be used"	
Fan power supply	3-phase 400 Vac, 50Hz		3-phase 400 Vac, 50Hz	
Capacity of fan power supply (kVA) 5)	67		78	
Maintenance				
Maintenance access	Front & Rear		Front & Rear	
Cable entry 6)	Bottom in /Bottom out		Bottom in /Bottom out	

ATV6000	M154A1010NA●		M169A1010NA●	
	Normal Duty	Heavy Duty	Normal Duty	Heavy Duty
Nominal data				
Type rating [kVA]	15400		16900	
Max. Motor power [kW] / [HP] 1)	12300/16494	9840/13195	13500/18103	11580/15529
Nominal Continuous output current [A] 1)	850	680	932	800
Max. output current with 120 %overload 1 min / 10 min [A]	1020	/	1119	/
Max. output current with 150 % overload1 min / 10 min [A]	/	1020	/	1200
Power cells				
Number of cells per phase	8		8	
Power cell rated current [A]	850		1000	
Power cell current with 120 %overload 1 min / 10 min [A]	1020		1200	
Max. output current for 3 sec [A]	1275		1500	
Characteristics with standard efficiency				
Efficiency at 100 % load (incl. Transformer) [%]	96.5%		96.5%	
Total losses at 100 % load [kW]	465.5	372.5	511.0	438.3
Air flow [m ³ /h]	108166		108166	
Noise level [dB (A)] @ 50 Hz	85		85	
Weight [kg / lb]	33463/73619		35477/78049	
Dimension [mm / inch] W*D*H 2)	14860*1800*3155/ 585.5*71*124.4		14860*1800*3155/ 585.5*71*124.4	
Connection				
Incoming cable type	symmetrical three-phase		symmetrical three-phase	
Typical cable size (mm ² / AWG) 3)	240*2/2*500MCM		240*2/2*500MCM	
Motor cable type	symmetrical three-phase(Use of shielded cable is advisable)		symmetrical three-phase(Use of shielded cable is advisable)	
Typical cable size (mm ² / AWG) 3)	240*2/2*500MCM		240*2/2*500MCM	
Motor cable Max. length 4)	1000 m		1000 m	
Grounding connection PE (mm ² / AWG)	150/300MCM		185/350MCM	
Control power supply	single phase, 230V, 50/60Hz,		single phase, 230V, 50/60Hz,	
Capacity of control power supply w/o options	1 kVA		1 kVA	
Capacity of control power supply with options	"depending on options to be used"		"depending on options to be used"	
Fan power supply	3-phase 400 Vac, 50Hz		3-phase 400 Vac, 50Hz	
Capacity of fan power supply (kVA) 5)	78		78	
Maintenance				
Maintenance access	Front & Rear		Front & Rear	
Cable entry 6)	Bottom in /Bottom out		Bottom in /Bottom out	

ATV6000	M181A1010NA●	
Nominal data	Normal Duty	Heavy Duty
Type rating [kVA]	18100	
Max. Motor power [kW] / [HP] 1)	14470/19404	11580/15529
Nominal Continuous output current [A] 1)	1000	800
Max. output current with 120 %overload 1 min / 10 min [A]	1200	/
Max. output current with 150 % overload 1 min / 10 min [A]	/	1200
Power cells		
Number of cells per phase	8	
Power cell rated current [A]	1000	
Power cell current with 120 %overload 1 min / 10 min [A]	1200	
Max. output current for 3 sec [A]	1500	
Characteristics with standard efficiency		
Efficiency at 100 % load (incl. Transformer) [%]	96.5%	
Total losses at 100 % load [kW]	547.6	438.3
Air flow [m ³ /h]	108166	
Noise level [dB (A)] @ 50 Hz	85	
Weight [kg / lb]	36963/81319	
Dimension [mm / inch] W*D*H 2)	14860*1800*3155/585.5*71*124.4	
Connection		
Incoming cable type	symmetrical three-phase	
Typical cable size (mm ² / AWG) 3)	120*3/3*0000	
Motor cable type	symmetrical three-phase(Use of shielded cable is advisable)	
Typical cable size (mm ² / AWG) 3)	240*2/2*500MCM	
Motor cable Max. length 4)	1000 m	
Grounding connection PE (mm ² / AWG)	185/350MCM	
Control power supply	single phase, 230V, 50/60Hz,	
Capacity of control power supply w/o options	1 kVA	
Capacity of control power supply with options	"depending on options to be used"	
Fan power supply	3-phase 400 Vac, 50Hz	
Capacity of fan power supply (kVA) 5)	78	
Maintenance		
Maintenance access	Front & Rear	
Cable entry 6)	Bottom in /Bottom out	
1) Values valid for synchronous motor and asynchronous motor. The specifications for the maximum motor shaft power is based on a motor efficiency of 95%. 2) Including the height of top cooling fans. 3) For CE products: Typical cable size values based on use of copper cables in cable tray laying. Incoming cable size is based on drive current rating. It has to be checked to be in accordance to mains short circuit capability and local and national electrical code requirement as well all other applicable regulations. 4) Variation in max. cable length may be possible depending on type cable and installation. For longer cable length between motor and drive contact Schneider Electric. 5) Contact Schneider Electric if N+1 redundancy cooling fan requested. 6) For other combination contact Schneider Electric.		

Layout Drawing and Dimensions

Layout Drawing

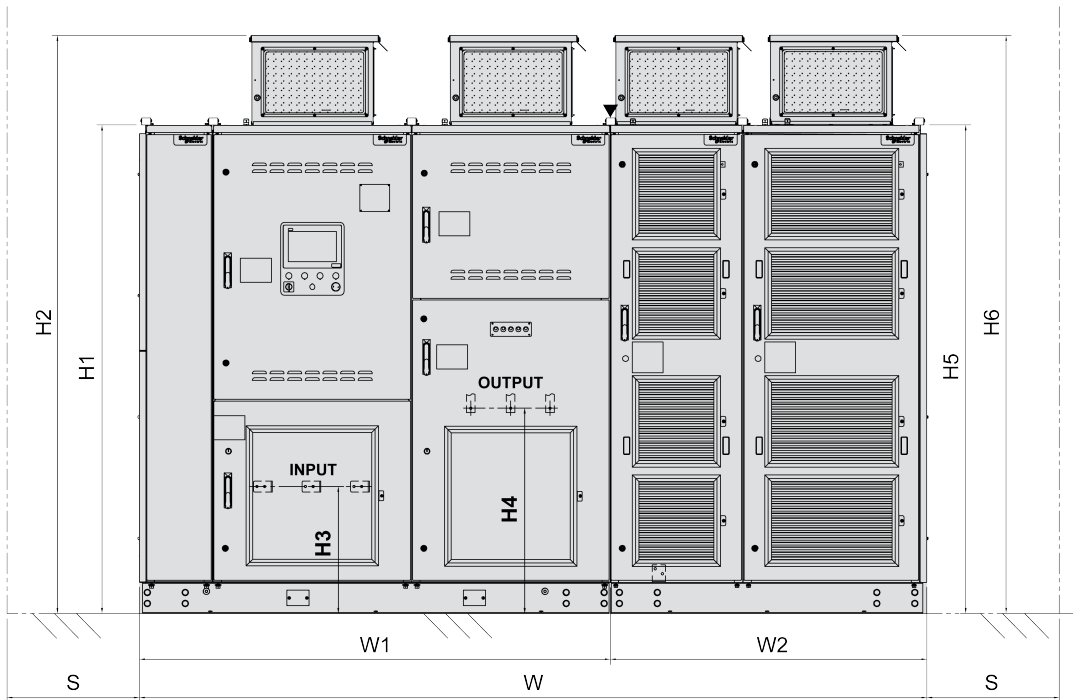

INPUT: Input terminal

OUTPUT: Output terminal

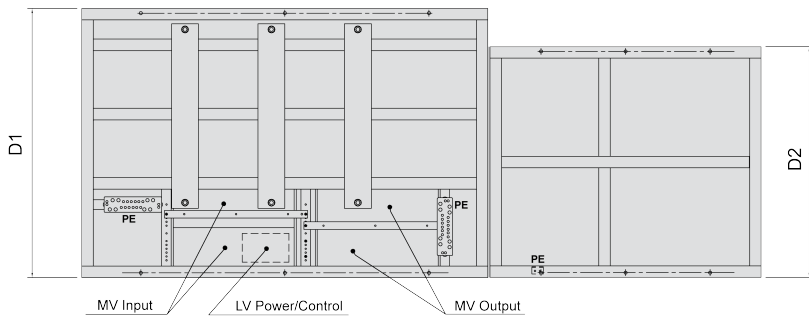

MV Input: MV Input cable area

LV Power/Control: LV Power/Control cable area

MV Output: MV Output cable area

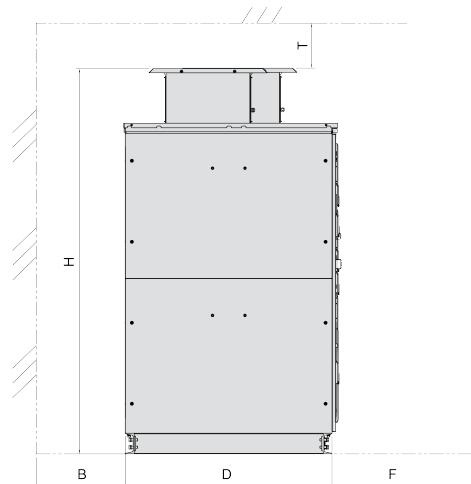

NOTE: Sketch is representing outline dimensions only, real cabinet arrangement is depending on power size.

Main dimensions - Output Voltage 10 kV

Product reference	Outer dimensions (mm / in)			Transformer cabinet			Powercell cabinet		
	W	H ^(b)	D	Fan Type	Fan Number	Weight [kg / lb]	Fan Type	Fan number	Weight [kg / lb]
ATV6000D450A1010...	3760	2754	1600	450	2	2509.7	400	2	1385.8
	148	108	63			5521.3			3048.8
ATV6000D500A1010...	3760	2754	1600	450	2	2571.7	400	2	1385.8
	148	108	63			5657.7			3048.8
ATV6000D630A1010...	3760	2754	1600	450	2	2732.6	400	2	1385.8
	148	108	63			6011.7			3048.8
ATV6000D700A1010...	3760	2754	1600	450	2	2819.3	400	2	1385.8
	148	108	63			6202.5			3048.8
ATV6000D790A1010...	3760	2754	1600	450	2	2930.7	400	2	1385.8
	148	108	63			6447.5			3048.8
ATV6000D890A1010...	4060	2754	1600	450	3	3182.1	400	2	1385.8
	160	108	63			7000.6			3048.8
ATV6000C100A1010...	4060	2754	1600	450	3	3318.3	400	2	1385.8
	160	108	63			7300.3			3048.8
ATV6000C118A1010...	4060	2754	1600	450	3	3541.1	400	2	1385.8
	160	108	63			7790.4			3048.8
ATV6000C138A1010...	4060	2754	1600	450	3	3788.7	400	2	1385.8
	160	108	63			8335.1			3048.8
ATV6000C150A1010...	4060	2754	1700	450	3	3969.9	400	2	1385.8
	160	108	67			8733.8			3048.8
ATV6000C180A1010...	4060	2754	1700	450	3	4341.4	400	2	1385.8
	160	108	67			9551.1			3048.8
ATV6000C200A1010...	5060	2795	1700	450	3	4589	560	3	2403.5
	199	110	67			10095.8			5287.7
ATV6000C225A1010...	5060	2795	1700	450	3	4898.5	560	3	2403.5
	199	110	67			10776.7			5287.7
ATV6000C272A1010...	5360	2795	1700	450	3	5512.4	560	3	2583.6
	211	110	67			12127.3			5683.9
ATV6000C300A1010...	6160	2754	1700	450	3	5859	400	4	3216.3
	243	108	67			12889.8			7075.9
ATV6000C325A1010...	6160	2754	1700	450	3	6168.6	400	4	3216.3
	243	108	67			13570.9			7075.9
ATV6000C350A1010...	6160	2754	1700	450	3	6478.1	400	4	3216.3
	243	108	67			14251.8			7075.9
ATV6000C398A1010...	6460	3155	1800	560	3	7606.5	400	4	3216.3
	254	124	71			16734.3			7075.9
ATV6000C438A1010...	6460	3155	1800	560	3	8101.7	560	4	3355.2
	254	124	71			17823.7			7381.4
ATV6000C507A1010...	6760	3155	1800	560	3	9070.7	560	4	3355.2
	266	124	71			19955.5			7381.4

Product reference	Outer dimensions (mm / in)			Transformer cabinet			Powercell cabinet		
	W	H ^(b)	D	Fan Type	Fan Number	Weight [kg / lb]	Fan Type	Fan number	Weight [kg / lb]
ATV6000C538A1010***	8560	3155	1800	560	3	9454.5	400	8	5797.2
	337	124	71			20799.9			12753.8
ATV6000C579A1010***	8560	3155	1800	560	3	9962.1	400	8	5797.2
	337	124	71			21916.6			12753.8
ATV6000C625A1010***	8560	3155	1800	560	3	10531.6	400	8	5797.2
	337	124	71			23169.5			12753.8
ATV6000C742A1010***	8860	3155	1800	560	4	12115.3	400	8	5797.2
	349	124	71			26653.7			12753.8
ATV6000C813A1010***	8860	3155	1800	560	4	12994.3	450	8	5769.2
	349	124	71			28587.5			12692.2
ATV6000C887A1010***	8860	3155	1800	560	4	13910.5	450	8	5769.2
	349	124	71			30603.1			12692.2
ATV6000C995A1010*** ^(a)	13660	3155	1800	560	3	16916.9	500	8	9133.3
	538	124	71			37217.2			20093.3
ATV6000M107A1010*** ^(a)	13660	3155	1800	560	3	17845.5	500	8	9133.3
	538	124	71			39260.1			20093.3
ATV6000M115A1010*** ^(a)	14260	3155	1800	560	3	19065.3	500	8	9133.3
	561	124	71			41943.7			20093.3
ATV6000M131A1010*** ^(a)	14860	3155	1800	560	4	21316.5	500	8	9133.3
	585	124	71			46896.3			20093.3
ATV6000M143A1010*** ^(a)	14860	3155	1800	560	4	22802.2	560	8	9298.1
	585	124	71			50164.8			20455.8
ATV6000M154A1010*** ^(a)	14860	3155	1800	560	4	24164.1	560	8	9298.1
	585	124	71			53161			20455.8
ATV6000M169A1010*** ^(a)	14860	3155	1800	560	4	26002	560	8	9474.7
	585	124	71			57204.4			20844.3
ATV6000M181A1010*** ^(a)	14860	3155	1800	560	4	27487.7	560	8	9474.7
	585	124	71			60472.9			20844.3

a) "W" is linked to dual transformer cabinets.

b) "H" is linked to higher size of transformer cabinet (H2) or power cell cabinet (H6).

Additional Dimensions - Output Voltage 10 kV

Product reference	Transformer Cabinet						Power cell Cabinet				Space Maintenance			
	(mm / in)						(mm / in)				(mm / in)			
	H1	H2	H3	H4	W1	D1	H5	H6	W2	D2	T	B (a)	F (b)	S (c)
ATV6000D450A1010***	2360	2754	500	930	2130	1600	2360	2690	1630	1200	≥500	0	1500	0
	93	108	20	37	84	63	93	106	64	47	≥20		59	
ATV6000D500A1010***	2360	2754	500	930	2130	1600	2360	2690	1630	1200	≥500	0	1500	0
	93	108	20	37	84	63	93	106	64	47	≥20		59	
ATV6000D630A1010***	2360	2754	500	930	2130	1600	2360	2690	1630	1200	≥500	0	1500	0
	93	108	20	37	84	63	93	106	64	47	≥20		59	
ATV6000D700A1010***	2360	2754	500	930	2130	1600	2360	2690	1630	1200	≥500	0	1500	0
	93	108	20	37	84	63	93	106	64	47	≥20		59	
ATV6000D790A1010***	2360	2754	500	930	2130	1600	2360	2690	1630	1200	≥500	0	1500	0
	93	108	20	37	84	63	93	106	64	47	≥20		59	
ATV6000D890A1010***	2360	2754	500	930	2430	1600	2360	2690	1630	1200	≥500	0	1500	0
	93	108	20	37	96	63	93	106	64	47	≥20		59	
ATV6000C100A1010***	2360	2754	500	930	2430	1600	2360	2690	1630	1200	≥500	0	1500	0
	93	108	20	37	96	63	93	106	64	47	≥20		59	
ATV6000C118A1010***	2360	2754	500	930	2430	1600	2360	2690	1630	1200	≥500	0	1500	0
	93	108	20	37	96	63	93	106	64	47	≥20		59	
ATV6000C138A1010***	2360	2754	500	930	2430	1600	2360	2690	1630	1200	≥500	0	1500	0
	93	108	20	37	96	63	93	106	64	47	≥20		59	
ATV6000C150A1010***	2360	2754	500	930	2430	1700	2360	2690	1630	1200	≥500	0	1500	0
	93	108	20	37	96	67	93	106	64	47	≥20		59	
ATV6000C180A1010***	2360	2754	500	930	2430	1700	2360	2690	1630	1200	≥500	0	1500	0
	93	108	20	37	96	67	93	106	64	47	≥20		59	
ATV6000C200A1010***	2360	2754	500	930	2430	1700	2360	2795	2630	1200	≥500	0	1500	0
	93	108	20	37	96	67	93	110	104	47	≥20		59	
ATV6000C225A1010***	2360	2754	500	930	2430	1700	2360	2795	2630	1200	≥500	0	1500	0
	93	108	20	37	96	67	93	110	104	47	≥20		59	
ATV6000C272A1010***	2360	2754	500	930	2730	1700	2360	2795	2630	1200	≥500	0	1500	0
	93	108	20	37	107	67	93	110	104	47	≥20		59	
ATV6000C300A1010***	2360	2754	500	930	2730	1700	2360	2690	3430	1200	≥500	≥600	1500	0
	93	108	20	37	107	67	93	106	135	47	≥20	≥24	59	
ATV6000C325A1010***	2360	2754	500	930	2730	1700	2360	2690	3430	1200	≥500	≥600	1500	0
	93	108	20	37	107	67	93	106	135	47	≥20	≥24	59	
ATV6000C350A1010***	2360	2754	500	930	2730	1700	2360	2690	3430	1200	≥500	≥600	1500	0
	93	108	20	37	107	67	93	106	135	47	≥20	≥24	59	
ATV6000C398A1010***	2720	3155	560	1290	3030	1800	2420	2750	3430	1200	≥500	≥600	1500	0
	107	124	22	51	119	71	95	108	135	47	≥20	≥24	59	
ATV6000C438A1010***	2720	3155	560	1290	3030	1800	2420	2855	3430	1200	≥500	≥600	1500	0
	107	124	22	51	119	71	95	112	135	47	≥20	≥24	59	
ATV6000C507A1010***	2720	3155	560	1290	3330	1800	2420	2855	3430	1200	≥500	≥600	1500	0
	107	124	22	51	131	71	95	112	135	47	≥20	≥24	59	

Product reference	Transformer Cabinet						Power cell Cabinet				Space Maintenance			
	(mm / in)						(mm / in)				(mm / in)			
	H1	H2	H3	H4	W1	D1	H5	H6	W2	D2	T	B (a)	F (b)	S(c)
ATV6000C538A1010***	2720 107	3155 124	560 22	1290 51	3330 131	1800 71	2420 95	2750 108	5230 206	1200 47	≥500 ≥20	≥600 ≥24	1500 59	0
ATV6000C579A1010***	2720 107	3155 124	560 22	1290 51	3330 131	1800 71	2420 95	2750 108	5230 206	1200 47	≥500 ≥20	≥600 ≥24	1500 59	0
ATV6000C625A1010***	2720 107	3155 124	560 22	1290 51	3330 131	1800 71	2420 95	2750 108	5230 206	1200 47	≥500 ≥20	≥600 ≥24	1500 59	0
ATV6000C742A1010***	2720 107	3155 124	560 22	1290 51	3630 143	1800 71	2420 95	2750 108	5230 206	1200 47	≥500 ≥20	≥600 ≥24	1500 59	0
ATV6000C813A1010***	2720 107	3155 124	560 22	1290 51	3630 143	1800 71	2420 95	2814 111	5230 206	1200 47	≥500 ≥20	≥600 ≥24	1500 59	0
ATV6000C887A1010***	2720 107	3155 124	560 22	1290 51	3630 143	1800 71	2420 95	2814 111	5230 206	1200 47	≥500 ≥20	≥600 ≥24	1500 59	0
ATV6000C995A1010***	2720 107	3155 124	560 22	1290 51	3030 119	1800 71	2420 95	2828 111	7630 300	1400 55	≥500 ≥20	≥600 ≥24	1500 59	0
ATV6000- M107A1010***	2720 107	3155 124	560 22	1290 51	3030 119	1800 71	2420 95	2828 111	7630 300	1400 55	≥500 ≥20	≥600 ≥24	1500 59	0
ATV6000M115A1010***	2720 107	3155 124	560 22	1290 51	3330 131	1800 71	2420 95	2828 111	7630 300	1400 55	≥500 ≥20	≥600 ≥24	1500 59	0
ATV6000- M131A1010***	2720 107	3155 124	560 22	1290 51	3630 143	1800 71	2420 95	2828 111	7630 300	1400 55	≥500 ≥20	≥600 ≥24	1500 59	0
ATV6000- M143A1010***	2720 107	3155 124	560 22	1290 51	3630 143	1800 71	2420 95	2855 112	7630 300	1400 55	≥500 ≥20	≥600 ≥24	1500 59	0
ATV6000- M154A1010***	2720 107	3155 124	560 22	1290 51	3630 143	1800 71	2420 95	2855 112	7630 300	1400 55	≥500 ≥20	≥600 ≥24	1500 59	0
ATV6000- M169A1010***	2720 107	3155 124	560 22	1290 51	3630 143	1800 71	2420 95	2855 112	7630 300	1600 63	≥500 ≥20	≥600 ≥24	1500 59	0
ATV6000- M181A1010***	2720 107	3155 124	560 22	1290 51	3630 143	1800 71	2420 95	2855 112	7630 300	1600 63	≥500 ≥20	≥600 ≥24	1500 59	0

a) Space could be required for installation and lifting lugs.

b) For easy handling with power cell exchange tool 2000mm (78.7 in) are recommended.

c) Space (600mm) could be required for maintenance of the front & rear access drive.

Output Voltage 11 kV

ATV6000D500A1111...ATV6000D690A1111

ATV6000	ATV6000D500A1111NA●		ATV6000D690A1111NA●	
Nominal data	Normal Duty	Heavy Duty	Normal Duty	Heavy Duty
Type rating [kVA]	500		690	
Max. Motor power [kW] / [HP] 1)	400/536	380/509	550/737	440/590
Nominal Continuous output current [A] 1)	25.1	24	35	28
Max. output current with 120 %overload 1 min / 10 min [A]	30.1	/	42	/
Max. output current with 150 % overload1 min / 10 min [A]	/	36	/	42
Power cells				
Number of cells per phase	9		9	
Power cell rated current [A]	35		35	
Power cell current with 120 %overload 1 min / 10 min [A]	42		42	
Max. output current for 3 sec [A]	52.5		52.5	
Characteristics with standard efficiency				
Efficiency at 100 % load (incl. Transformer) [%]	96.0%		96.0%	
Total losses at 100 % load [kW]	17.5	16.6	24.0	19.2
Air flow [m³/h]	14580		14580	
Noise level [dB (A)] @ 50 Hz	80		80	
Weight [kg / lb]	4041/8890		4276/9407	
Dimension [mm / inch] W*D*H 2)	3860*1600*2754/ 152.1*63.1*108.6		3860*1600*2754/ 152.1*63.1*108.6	
Connection				
Incoming cable type	symmetrical three-phase		symmetrical three-phase	
Typical cable size (mm² / AWG) 3)	95/000		95/000	
Motor cable type	symmetrical three-phase(Use of shielded cable is advisable)		symmetrical three-phase(Use of shielded cable is advisable)	
Typical cable size (mm² / AWG) 3)	25/4		25/4	
Motor cable Max. length 4)	1000 m		1000 m	
Grounding connection PE (mm² / AWG)	50/0		50/0	
Control power supply	single phase, 230V, 50/60Hz,		single phase, 230V, 50/60Hz,	
Capacity of control power supply w/o options	1 kVA		1 kVA	
Capacity of control power supply with options	"depending on options to be used"		"depending on options to be used"	
Fan power supply	3-phase 400 Vac, 50Hz		3-phase 400 Vac, 50Hz	
Capacity of fan power supply (kVA) 5)	6		6	
Maintenance				
Maintenance access	Front		Front	

ATV6000	ATV6000D500A1111NA●	ATV6000D690A1111NA●
Cable entry 6)	Bottom in /Bottom out	Bottom in /Bottom out
<p>1) Values valid for synchronous motor and asynchronous motor. The specifications for the maximum motor shaft power is based on a motor efficiency of 95%.</p> <p>2) Including the height of top cooling fans.</p> <p>3) For CE products: Typical cable size values based on use of copper cables in cable tray laying. Incoming cable size is based on drive current rating. It has to be checked to be in accordance to mains short circuit capability and local and national electrical code requirement as well all other applicable regulations.</p> <p>4) Variation in max. cable length may be possible depending on type cable and installation. For longer cable length between motor and drive contact Schneider Electric.</p> <p>5) Contact Schneider Electric if N+1 redundancy cooling fan requested.</p> <p>6) For other combination contact Schneider Electric.</p>		

ATV6000D790A1111...ATV6000C199A1111

ATV6000	ATV6000D790A1111NA●		ATV6000C100A1111NA●	
Nominal data	Normal Duty	Heavy Duty	Normal Duty	Heavy Duty
Type rating [kVA]	790		1000	
Max. Motor power [kW] / [HP] 1)	630/844	600/804	800/1072	760/1019
Nominal Continuous output current [A] 1)	39.6	38	50.2	48
Max. output current with 120 %overload 1 min / 10 min [A]	47.5	/	60.2	/
Max. output current with 150 % overload 1 min / 10 min [A]	/	57	/	72
Power cells				
Number of cells per phase	9		9	
Power cell rated current [A]	65		65	
Power cell current with 120 %overload 1 min / 10 min [A]	78		78	
Max. output current for 3 sec [A]	97.5		97.5	
Characteristics with standard efficiency				
Efficiency at 100 % load (incl. Transformer) [%]	96.0%		96.0%	
Total losses at 100 % load [kW]	27.4	26.2	34.9	33.1
Air flow [m³/h]	17400		17400	
Noise level [dB (A)] @ 50 Hz	80		80	
Weight [kg / lb]	4528/9962		4788/10534	
Dimension [mm / inch] W*D*H 2)	4160*1600*2754/ 164*63.1*108.6		4160*1600*2754/ 164*63.1*108.6	
Connection				
Incoming cable type	symmetrical three-phase		symmetrical three-phase	
Typical cable size (mm² / AWG) 3)	95/000		95/000	
Motor cable type	symmetrical three-phase(Use of shielded cable is advisable)		symmetrical three-phase(Use of shielded cable is advisable)	
Typical cable size (mm² / AWG) 3)	25/4		25/4	
Motor cable Max. length 4)	1000 m		1000 m	
Grounding connection PE (mm² / AWG)	50/0		50/0	
Control power supply	single phase, 230V, 50/60Hz,		single phase, 230V, 50/60Hz,	
Capacity of control power supply w/o options	1 kVA		1 kVA	
Capacity of control power supply with options	"depending on options to be used"		"depending on options to be used"	
Fan power supply	3-phase 400 Vac, 50Hz		3-phase 400 Vac, 50Hz	
Capacity of fan power supply (kVA) 5)	7		7	
Maintenance				
Maintenance access	Front		Front	
Cable entry 6)	Bottom in /Bottom out		Bottom in /Bottom out	

ATV6000	ATV6000C129A1111NA•		ATV6000C150A1111NA•	
Nominal data	Normal Duty	Heavy Duty	Normal Duty	Heavy Duty
Type rating [kVA]	1290		1500	
Max. Motor power [kW] / [HP] 1)	1030/1381	820/1099	1200/1609	1140/1528
Nominal Continuous output current [A] 1)	65	52	75.3	72
Max. output current with 120 % overload 1 min / 10 min [A]	78	/	90.3	/
Max. output current with 150 % overload 1 min / 10 min [A]	/	78	/	108
Power cells				
Number of cells per phase	9		9	
Power cell rated current [A]	65		100	
Power cell current with 120 % overload 1 min / 10 min [A]	78		120	
Max. output current for 3 sec [A]	97.5		150	
Characteristics with standard efficiency				
Efficiency at 100 % load (incl. Transformer) [%]	96.0%		96.0%	
Total losses at 100 % load [kW]	44.9	35.7	52.2	49.6
Air flow [m ³ /h]	17400		17400	
Noise level [dB (A)] @ 50 Hz	80		80	
Weight [kg / lb]	5147/11323		5407/11895	
Dimension [mm / inch] W*D*H 2)	4160*1600*2754/ 164*63.1*108.6		4160*1600*2754/ 164*63.1*108.6	
Connection				
Incoming cable type	symmetrical three-phase		symmetrical three-phase	
Typical cable size (mm ² / AWG) 3)	95/000		95/000	
Motor cable type	symmetrical three-phase(Use of shielded cable is advisable)		symmetrical three-phase(Use of shielded cable is advisable)	
Typical cable size (mm ² / AWG) 3)	25/4		25/4	
Motor cable Max. length 4)	1000 m		1000 m	
Grounding connection PE (mm ² / AWG)	50/0		50/0	
Control power supply	single phase, 230V, 50/60Hz,		single phase, 230V, 50/60Hz,	
Capacity of control power supply w/o options	1 kVA		1 kVA	
Capacity of control power supply with options	"depending on options to be used"		"depending on options to be used"	
Fan power supply	3-phase 400 Vac, 50Hz		3-phase 400 Vac, 50Hz	
Capacity of fan power supply (kVA) 5)	7		7	
Maintenance				
Maintenance access	Front		Front	
Cable entry 6)	Bottom in /Bottom out		Bottom in /Bottom out	

ATV6000	ATV6000C175A1111NA●		ATV6000C199A1111NA●	
Nominal data	Normal Duty	Heavy Duty	Normal Duty	Heavy Duty
Type rating [kVA]	1750		1990	
Max. Motor power [kW] / [HP] 1)	1400/1877	1270/1703	1590/2132	1270/1703
Nominal Continuous output current [A] 1)	87.9	80	100	80
Max. output current with 120 %overload 1 min / 10 min [A]	105	/	120	/
Max. output current with 150 % overload 1 min / 10 min [A]	/	120	/	120
Power cells				
Number of cells per phase	9		9	
Power cell rated current [A]	100		100	
Power cell current with 120 %overload 1 min / 10 min [A]	120		120	
Max. output current for 3 sec [A]	150		150	
Characteristics with standard efficiency				
Efficiency at 100 % load (incl. Transformer) [%]	96.0%		96.0%	
Total losses at 100 % load [kW]	60.9	55.3	69.1	55.3
Air flow [m³/h]	17400		17400	
Noise level [dB (A)] @ 50 Hz	80		80	
Weight [kg / lb]	5716/12575		6013/13229	
Dimension [mm / inch] W*D*H 2)	4160*1600*2754/ 164*63.1*108.6		4160*1600*2754/ 164*63.1*108.6	
Connection				
Incoming cable type	symmetrical three-phase		symmetrical three-phase	
Typical cable size (mm² / AWG) 3)	95/000		95/000	
Motor cable type	symmetrical three-phase(Use of shielded cable is advisable)		symmetrical three-phase(Use of shielded cable is advisable)	
Typical cable size (mm² / AWG) 3)	25/4		25/4	
Motor cable Max. length 4)	1000 m		1000 m	
Grounding connection PE (mm² / AWG)	50/0		50/0	
Control power supply	single phase, 230V, 50/60Hz,		single phase, 230V, 50/60Hz,	
Capacity of control power supply w/o options	1 kVA		1 kVA	
Capacity of control power supply with options	"depending on options to be used"		"depending on options to be used"	
Fan power supply	3-phase 400 Vac, 50Hz		3-phase 400 Vac, 50Hz	
Capacity of fan power supply (kVA) 5)	7		7	
Maintenance				
Maintenance access	Front		Front	
Cable entry 6)	Bottom in /Bottom out		Bottom in /Bottom out	
1) Values valid for synchronous motor and asynchronous motor. The specifications for the maximum motor shaft power is based on a motor efficiency of 95%. 2) Including the height of top cooling fans. 3) For CE products: Typical cable size values based on use of copper cables in cable tray laying. Incoming cable size is based on drive current rating. It has to be checked to be in accordance to mains short circuit capability and local and national electrical code requirement as well all other applicable regulations. 4) Variation in max. cable length may be possible depending on type cable and installation. For longer cable length between motor and drive contact Schneider Electric. 5) Contact Schneider Electric if N+1 redundancy cooling fan requested. 6) For other combination contact Schneider Electric.				

ATV6000C225A1111

ATV6000	ATV6000C225A1111NA•	
Nominal data	Normal Duty	Heavy Duty
Type rating [kVA]	2250	
Max. Motor power [kW] / [HP] 1)	1800/2413	1720/2306
Nominal Continuous output current [A] 1)	113	108
Max. output current with 120 %overload 1 min / 10 min [A]	136	/
Max. output current with 150 % overload 1 min / 10 min [A]	/	162
Power cells		
Number of cells per phase	9	
Power cell rated current [A]	150	
Power cell current with 120 %overload 1 min / 10 min [A]	180	
Max. output current for 3 sec [A]	225	
Characteristics with standard efficiency		
Efficiency at 100 % load (incl. Transformer) [%]	96.0%	
Total losses at 100 % load [kW]	78.3	74.8
Air flow [m ³ /h]	28696	
Noise level [dB (A)] @ 50 Hz	83	
Weight [kg / lb]	7463/16419	
Dimension [mm / inch] W*D*H 2)	5160*1700*2795/203.4*67*110.2	
Connection		
Incoming cable type	symmetrical three-phase	
Typical cable size (mm ² / AWG) 3)	95/000	
Motor cable type	symmetrical three-phase(Use of shielded cable is advisable)	
Typical cable size (mm ² / AWG) 3)	35/2	
Motor cable Max. length 4)	1000 m	
Grounding connection PE (mm ² / AWG)	50/0	
Control power supply	single phase, 230V, 50/60Hz,	
Capacity of control power supply w/o options	1 kVA	
Capacity of control power supply with options	"depending on options to be used"	
Fan power supply	3-phase 400 Vac, 50Hz	
Capacity of fan power supply (kVA) 5)	19	
Maintenance		
Maintenance access	Front	
Cable entry 6)	Bottom in /Bottom out	
<p>1) Values valid for synchronous motor and asynchronous motor. The specifications for the maximum motor shaft power is based on a motor efficiency of 95%.</p> <p>2) Including the height of top cooling fans.</p> <p>3) For CE products: Typical cable size values based on use of copper cables in cable tray laying. Incoming cable size is based on drive current rating. It has to be checked to be in accordance to mains short circuit capability and local and national electrical code requirement as well all other applicable regulations.</p> <p>4) Variation in max. cable length may be possible depending on type cable and installation. For longer cable length between motor and drive contact Schneider Electric.</p> <p>5) Contact Schneider Electric if N+1 redundancy cooling fan requested.</p> <p>6) For other combination contact Schneider Electric.</p>		

ATV6000C250A1111...ATV6000C298A1111

ATV6000	ATV6000C250A1111NA●		ATV6000C298A1111NA●	
Nominal data	Normal Duty	Heavy Duty	Normal Duty	Heavy Duty
Type rating [kVA]	2500		2980	
Max. Motor power [kW] / [HP] 1)	2000/2682	1910/2561	2380/3191	1910/2561
Nominal Continuous output current [A] 1)	126	120	150	120
Max. output current with 120 %overload 1 min / 10 min [A]	151	/	180	/
Max. output current with 150 % overload 1 min / 10 min [A]	/	180	/	180
Power cells				
Number of cells per phase	9		9	
Power cell rated current [A]	150		150	
Power cell current with 120 %overload 1 min / 10 min [A]	180		180	
Max. output current for 3 sec [A]	225		225	
Characteristics with standard efficiency				
Efficiency at 100 % load (incl. Transformer) [%]	96.0%		96.0%	
Total losses at 100 % load [kW]	87.0	83.1	103.5	83.1
Air flow [m³/h]	29416		29416	
Noise level [dB (A)] @ 50 Hz	83		83	
Weight [kg / lb]	7987/17571		8581/18878	
Dimension [mm / inch] W*D*H 2)	5460*1700*2795/ 215.2*67*110.2		5460*1700*2795/ 215.2*67*110.2	
Connection				
Incoming cable type	symmetrical three-phase		symmetrical three-phase	
Typical cable size (mm² / AWG) 3)	95/000		95/000	
Motor cable type	symmetrical three-phase(Use of shielded cable is advisable)		symmetrical three-phase(Use of shielded cable is advisable)	
Typical cable size (mm² / AWG) 3)	35/2		35/2	
Motor cable Max. length 4)	1000 m		1000 m	
Grounding connection PE (mm² / AWG)	50/0		50/0	
Control power supply	single phase, 230V, 50/60Hz,		single phase, 230V, 50/60Hz,	
Capacity of control power supply w/o options	1 kVA		1 kVA	
Capacity of control power supply with options	"depending on options to be used"		"depending on options to be used"	
Fan power supply	3-phase 400 Vac, 50Hz		3-phase 400 Vac, 50Hz	
Capacity of fan power supply (kVA) 5)	19		19	
Maintenance				
Maintenance access	Front		Front	
Cable entry 6)	Bottom in /Bottom out		Bottom in /Bottom out	
1) Values valid for synchronous motor and asynchronous motor. The specifications for the maximum motor shaft power is based on a motor efficiency of 95%. 2) Including the height of top cooling fans. 3) For CE products: Typical cable size values based on use of copper cables in cable tray laying. Incoming cable size is based on drive current rating. It has to be checked to be in accordance to mains short circuit capability and local and national electrical code requirement as well all other applicable regulations. 4) Variation in max. cable length may be possible depending on type cable and installation. For longer cable length between motor and drive contact Schneider Electric. 5) Contact Schneider Electric if N+1 redundancy cooling fan requested. 6) For other combination contact Schneider Electric.				

ATV6000C325A1111...ATV6000C375A1111

ATV6000	ATV6000C325A1111NA●		ATV6000C375A1111NA●	
Nominal data	Normal Duty	Heavy Duty	Normal Duty	Heavy Duty
Type rating [kVA]	3250		3750	
Max. Motor power [kW] / [HP] 1)	2600/3486	2480/3325	3000/4023	2540/3406
Nominal Continuous output current [A] 1)	163	156	188	160
Max. output current with 120 %overload 1 min / 10 min [A]	196	/	226	/
Max. output current with 150 % overload 1 min / 10 min [A]	/	234	/	240
Power cells				
Number of cells per phase	9		9	
Power cell rated current [A]	200		200	
Power cell current with 120 %overload 1 min / 10 min [A]	240		240	
Max. output current for 3 sec [A]	300		300	
Characteristics with standard efficiency				
Efficiency at 100 % load (incl. Transformer) [%]	96.0%		96.0%	
Total losses at 100 % load [kW]	113.0	107.8	130.4	110.5
Air flow [m ³ /h]	25848		25848	
Noise level [dB (A)] @ 50 Hz	80		83	
Weight [kg / lb]	9851/21672		10470/23034	
Dimension [mm / inch] W*D*H 2)	6660*1700*2754/ 262.5*67*108.6		6660*1700*2754/ 262.5*67*108.6	
Connection				
Incoming cable type	symmetrical three-phase		symmetrical three-phase	
Typical cable size (mm ² / AWG) 3)	95/000		95/000	
Motor cable type	symmetrical three-phase(Use of shielded cable is advisable)		symmetrical three-phase(Use of shielded cable is advisable)	
Typical cable size (mm ² / AWG) 3)	35/2		50/0	
Motor cable Max. length 4)	1000 m		1000 m	
Grounding connection PE (mm ² / AWG)	50/0		50/0	
Control power supply	single phase, 230V, 50/60Hz,		single phase, 230V, 50/60Hz,	
Capacity of control power supply w/o options	1 kVA		1 kVA	
Capacity of control power supply with options	"depending on options to be used"		"depending on options to be used"	
Fan power supply	3-phase 400 Vac, 50Hz		3-phase 400 Vac, 50Hz	
Capacity of fan power supply (kVA) 5)	10		10	
Maintenance				
Maintenance access	Front		Front	
Cable entry 6)	Bottom in /Bottom out		Bottom in /Bottom out	
<p>1) Values valid for synchronous motor and asynchronous motor. The specifications for the maximum motor shaft power is based on a motor efficiency of 95%.</p> <p>2) Including the height of top cooling fans.</p> <p>3) For CE products: Typical cable size values based on use of copper cables in cable tray laying. Incoming cable size is based on drive current rating. It has to be checked to be in accordance to mains short circuit capability and local and national electrical code requirement as well all other applicable regulations.</p> <p>4) Variation in max. cable length may be possible depending on type cable and installation. For longer cable length between motor and drive contact Schneider Electric.</p> <p>5) Contact Schneider Electric if N+1 redundancy cooling fan requested.</p> <p>6) For other combination contact Schneider Electric.</p>				

ATV6000C438A1111

ATV6000	ATV6000C438A1111NA•	
Nominal data	Normal Duty	Heavy Duty
Type rating [kVA]	4380	
Max. Motor power [kW] / [HP] 1)	3500/4693	2800/3754
Nominal Continuous output current [A] 1)	220	176
Max. output current with 120 %overload 1 min / 10 min [A]	264	/
Max. output current with 150 % overload 1 min / 10 min [A]	/	264
Power cells		
Number of cells per phase	9	
Power cell rated current [A]	220	
Power cell current with 120 %overload 1 min / 10 min [A]	264	
Max. output current for 3 sec [A]	330	
Characteristics with standard efficiency		
Efficiency at 100 % load (incl. Transformer) [%]	96.0%	
Total losses at 100 % load [kW]	152.2	121.7
Air flow [m³/h]	35053	
Noise level [dB (A)] @ 50 Hz	83	
Weight [kg / lb]	11784/25925	
Dimension [mm / inch] W*D*H 2)	6960*1800*3155/274.3*71*124.4	
Connection		
Incoming cable type	symmetrical three-phase	
Typical cable size (mm² / AWG) 3)	95/000	
Motor cable type	symmetrical three-phase(Use of shielded cable is advisable)	
Typical cable size (mm² / AWG) 3)	70/00	
Motor cable Max. length 4)	1000 m	
Grounding connection PE (mm² / AWG)	50/0	
Control power supply	single phase, 230V, 50/60Hz,	
Capacity of control power supply w/o options	1 kVA	
Capacity of control power supply with options	"depending on options to be used"	
Fan power supply	3-phase 400 Vac, 50Hz	
Capacity of fan power supply (kVA) 5)	20	
Maintenance		
Maintenance access	Front	
Cable entry 6)	Bottom in /Bottom out	
1) Values valid for synchronous motor and asynchronous motor. The specifications for the maximum motor shaft power is based on a motor efficiency of 95%. 2) Including the height of top cooling fans. 3) For CE products: Typical cable size values based on use of copper cables in cable tray laying. Incoming cable size is based on drive current rating. It has to be checked to be in accordance to mains short circuit capability and local and national electrical code requirement as well all other applicable regulations. 4) Variation in max. cable length may be possible depending on type cable and installation. For longer cable length between motor and drive contact Schneider Electric. 5) Contact Schneider Electric if N+1 redundancy cooling fan requested. 6) For other combination contact Schneider Electric.		

ATV6000C557A1111

ATV6000	ATV6000C557A1111NA•	
Nominal data	Normal Duty	Heavy Duty
Type rating [kVA]	5570	
Max. Motor power [kW] / [HP] 1)	4450/5967	3560/4774
Nominal Continuous output current [A] 1)	280	224
Max. output current with 120 %overload 1 min / 10 min [A]	336	/
Max. output current with 150 % overload 1 min / 10 min [A]	/	336
Power cells		
Number of cells per phase	9	
Power cell rated current [A]	280	
Power cell current with 120 %overload 1 min / 10 min [A]	336	
Max. output current for 3 sec [A]	420	
Characteristics with standard efficiency		
Efficiency at 100 % load (incl. Transformer) [%]	96.5%	
Total losses at 100 % load [kW]	168.5	134.8
Air flow [m ³ /h]	52656	
Noise level [dB (A)] @ 50 Hz	85	
Weight [kg / lb]	13604/29929	
Dimension [mm / inch] W*D*H 2)	7460*1800*3155/294*71*124.4	
Connection		
Incoming cable type	symmetrical three-phase	
Typical cable size (mm ² / AWG) 3)	95/000	
Motor cable type	symmetrical three-phase(Use of shielded cable is advisable)	
Typical cable size (mm ² / AWG) 3)	95/000	
Motor cable Max. length 4)	1000 m	
Grounding connection PE (mm ² / AWG)	50/0	
Control power supply	single phase, 230V, 50/60Hz,	
Capacity of control power supply w/o options	1 kVA	
Capacity of control power supply with options	"depending on options to be used"	
Fan power supply	3-phase 400 Vac, 50Hz	
Capacity of fan power supply (kVA) 5)	39	
Maintenance		
Maintenance access	Front	
Cable entry 6)	Bottom in /Bottom out	
<p>1) Values valid for synchronous motor and asynchronous motor. The specifications for the maximum motor shaft power is based on a motor efficiency of 95%.</p> <p>2) Including the height of top cooling fans.</p> <p>3) For CE products: Typical cable size values based on use of copper cables in cable tray laying. Incoming cable size is based on drive current rating. It has to be checked to be in accordance to mains short circuit capability and local and national electrical code requirement as well all other applicable regulations.</p> <p>4) Variation in max. cable length may be possible depending on type cable and installation. For longer cable length between motor and drive contact Schneider Electric.</p> <p>5) Contact Schneider Electric if N+1 redundancy cooling fan requested.</p> <p>6) For other combination contact Schneider Electric.</p>		

ATV6000C637A1111...ATV6000C975A1111

ATV6000	ATV6000C637A1111NA●		ATV6000C713A1111NA●	
Nominal data	Normal Duty	Heavy Duty	Normal Duty	Heavy Duty
Type rating [kVA]	6370		7130	
Max. Motor power [kW] / [HP] 1)	5090/6825	4070/5457	5700/7643	5220/7000
Nominal Continuous output current [A] 1)	320	256	358	328
Max. output current with 120 %overload 1 min / 10 min [A]	384	/	429	/
Max. output current with 150 % overload 1 min / 10 min [A]	/	384	/	492
Power cells				
Number of cells per phase	9		9	
Power cell rated current [A]	320		410	
Power cell current with 120 %overload 1 min / 10 min [A]	384		492	
Max. output current for 3 sec [A]	480		615	
Characteristics with standard efficiency				
Efficiency at 100 % load (incl. Transformer) [%]	96.5%		96.5%	
Total losses at 100 % load [kW]	192.7	154.1	215.8	197.6
Air flow [m ³ /h]	54299		54299	
Noise level [dB (A)] @ 50 Hz	83		83	
Weight [kg / lb]	17295/38049		18236/40119	
Dimension [mm / inch] W*D*H 2)	9460*1800*3155/ 372.8*71*124.4		9460*1800*3155/ 372.8*71*124.4	
Connection				
Incoming cable type	symmetrical three-phase		symmetrical three-phase	
Typical cable size (mm ² / AWG) 3)	120/0000		150/300MCM	
Motor cable type	symmetrical three-phase(Use of shielded cable is advisable)		symmetrical three-phase(Use of shielded cable is advisable)	
Typical cable size (mm ² / AWG) 3)	120/0000		150/300MCM	
Motor cable Max. length 4)	1000 m		1000 m	
Grounding connection PE (mm ² / AWG)	50/0		70/00	
Control power supply	single phase, 230V, 50/60Hz,		single phase, 230V, 50/60Hz,	
Capacity of control power supply w/o options	1 kVA		1 kVA	
Capacity of control power supply with options	"depending on options to be used"		"depending on options to be used"	
Fan power supply	3-phase 400 Vac, 50Hz		3-phase 400 Vac, 50Hz	
Capacity of fan power supply (kVA) 5)	29		29	
Maintenance				
Maintenance access	Front & Rear		Front & Rear	
Cable entry 6)	Bottom in /Bottom out		Bottom in /Bottom out	

ATV6000	ATV6000C817A1111NA●		ATV6000C888A1111NA●	
Nominal data	Normal Duty	Heavy Duty	Normal Duty	Heavy Duty
Type rating [kVA]	8170		8880	
Max. Motor power [kW] / [HP] 1)	6530/8756	5220/7000	7100/9521	6240/8367
Nominal Continuous output current [A] 1)	410	328	446	392
Max. output current with 120 %overload 1 min / 10 min [A]	492	/	535	/
Max. output current with 150 % overload1 min / 10 min [A]	/	492	/	588
Power cells				
Number of cells per phase	9		9	
Power cell rated current [A]	410		490	
Power cell current with 120 %overload 1 min / 10 min [A]	492		588	
Max. output current for 3 sec [A]	615		735	
Characteristics with standard efficiency				
Efficiency at 100 % load (incl. Transformer) [%]	96.5%		96.5%	
Total losses at 100 % load [kW]	247.2	197.6	268.8	236.2
Air flow [m ³ /h]	54299		57491	
Noise level [dB (A)] @ 50 Hz	83		85	
Weight [kg / lb]	19523/42951		20371/44816	
Dimension [mm / inch] W*D*H 2)	9460*1800*3155/ 372.8*71*124.4		9460*1800*3155/ 372.8*71*124.4	
Connection				
Incoming cable type	symmetrical three-phase		symmetrical three-phase	
Typical cable size (mm ² / AWG) 3)	185/350MCM		240/500MCM	
Motor cable type	symmetrical three-phase(Use of shielded cable is advisable)		symmetrical three-phase(Use of shielded cable is advisable)	
Typical cable size (mm ² / AWG) 3)	185/350MCM		240/500MCM	
Motor cable Max. length 4)	1000 m		1000 m	
Grounding connection PE (mm ² / AWG)	70/00		95/000	
Control power supply	single phase, 230V, 50/60Hz,		single phase, 230V, 50/60Hz,	
Capacity of control power supply w/o options	1 kVA		1 kVA	
Capacity of control power supply with options	"depending on options to be used"		"depending on options to be used"	
Fan power supply	3-phase 400 Vac, 50Hz		3-phase 400 Vac, 50Hz	
Capacity of fan power supply (kVA) 5)	29		32	
Maintenance				
Maintenance access	Front & Rear		Front & Rear	
Cable entry 6)	Bottom in /Bottom out		Bottom in /Bottom out	

ATV6000	ATV6000C975A1111NA●	
Nominal data	Normal Duty	Heavy Duty
Type rating [kVA]	9750	
Max. Motor power [kW] / [HP] 1)	7800/10459	6240/8367
Nominal Continuous output current [A] 1)	490	392
Max. output current with 120 %overload 1 min / 10 min [A]	588	/
Max. output current with 150 % overload 1 min / 10 min [A]	/	588
Power cells		
Number of cells per phase	9	
Power cell rated current [A]	490	
Power cell current with 120 %overload 1 min / 10 min [A]	588	
Max. output current for 3 sec [A]	735	
Characteristics with standard efficiency		
Efficiency at 100 % load (incl. Transformer) [%]	96.5%	
Total losses at 100 % load [kW]	295.3	236.2
Air flow [m³/h]	57491	
Noise level [dB (A)] @ 50 Hz	85	
Weight [kg / lb]	21448/47186	
Dimension [mm / inch] W*D*H 2)	9460*1800*3155/372.8*71*124.4	
Connection		
Incoming cable type	symmetrical three-phase	
Typical cable size (mm² / AWG) 3)	95*2/2*00	
Motor cable type	symmetrical three-phase(Use of shielded cable is advisable)	
Typical cable size (mm² / AWG) 3)	240/500MCM	
Motor cable Max. length 4)	1000 m	
Grounding connection PE (mm² / AWG)	95/000	
Control power supply	single phase, 230V, 50/60Hz,	
Capacity of control power supply w/o options	1 kVA	
Capacity of control power supply with options	"depending on options to be used"	
Fan power supply	3-phase 400 Vac, 50Hz	
Capacity of fan power supply (kVA) 5)	32	
Maintenance		
Maintenance access	Front & Rear	
Cable entry 6)	Bottom in /Bottom out	
1) Values valid for synchronous motor and asynchronous motor. The specifications for the maximum motor shaft power is based on a motor efficiency of 95%. 2) Including the height of top cooling fans. 3) For CE products: Typical cable size values based on use of copper cables in cable tray laying. Incoming cable size is based on drive current rating. It has to be checked to be in accordance to mains short circuit capability and local and national electrical code requirement as well all other applicable regulations. 4) Variation in max. cable length may be possible depending on type cable and installation. For longer cable length between motor and drive contact Schneider Electric. 5) Contact Schneider Electric if N+1 redundancy cooling fan requested. 6) For other combination contact Schneider Electric.		

ATV600M110A1111

ATV6000	ATV6000M110A1111NA•	
Nominal data	Normal Duty	Heavy Duty
Type rating [kVA]	11000	
Max. Motor power [kW] / [HP] 1)	8760/11747	7000/9387
Nominal Continuous output current [A] 1)	550	440
Max. output current with 120 %overload 1 min / 10 min [A]	660	/
Max. output current with 150 % overload 1 min / 10 min [A]	/	660
Power cells		
Number of cells per phase	9	
Power cell rated current [A]	550	
Power cell current with 120 %overload 1 min / 10 min [A]	660	
Max. output current for 3 sec [A]	825	
Characteristics with standard efficiency		
Efficiency at 100 % load (incl. Transformer) [%]	96.5%	
Total losses at 100 % load [kW]	331.6	265.0
Air flow [m ³ /h]	95160	
Noise level [dB (A)] @ 50 Hz	85	
Weight [kg / lb]	28623/62971	
Dimension [mm / inch] W*D*H 2)	15060*1800*3155/593.4*71*124.4	
Connection		
Incoming cable type	symmetrical three-phase	
Typical cable size (mm ² / AWG) 3)	95*2/2*000	
Motor cable type	symmetrical three-phase(Use of shielded cable is advisable)	
Typical cable size (mm ² / AWG) 3)	95*2/2*000	
Motor cable Max. length 4)	1000 m	
Grounding connection PE (mm ² / AWG)	95/000	
Control power supply	single phase, 230V, 50/60Hz,	
Capacity of control power supply w/o options	1 kVA	
Capacity of control power supply with options	"depending on options to be used"	
Fan power supply	3-phase 400 Vac, 50Hz	
Capacity of fan power supply (kVA) 5)	61	
Maintenance		
Maintenance access	Front & Rear	
Cable entry 6)	Bottom in /Bottom out	
<p>1) Values valid for synchronous motor and asynchronous motor. The specifications for the maximum motor shaft power is based on a motor efficiency of 95%.</p> <p>2) Including the height of top cooling fans.</p> <p>3) For CE products: Typical cable size values based on use of copper cables in cable tray laying. Incoming cable size is based on drive current rating. It has to be checked to be in accordance to mains short circuit capability and local and national electrical code requirement as well all other applicable regulations.</p> <p>4) Variation in max. cable length may be possible depending on type cable and installation. For longer cable length between motor and drive contact Schneider Electric.</p> <p>5) Contact Schneider Electric if N+1 redundancy cooling fan requested.</p> <p>6) For other combination contact Schneider Electric.</p>		

ATV6000M125A1111...ATV6000M144A1111

ATV6000	ATV6000M125A1111NA●		ATV6000M144A1111NA●	
Nominal data	Normal Duty	Heavy Duty	Normal Duty	Heavy Duty
Type rating [kVA]	12500		14400	
Max. Motor power [kW] / [HP] 1)	10000/13410	9170/12297	11460/15368	9170/12297
Nominal Continuous output current [A] 1)	628	576	720	576
Max. output current with 120 %overload 1 min / 10 min [A]	753	/	864	/
Max. output current with 150 % overload1 min / 10 min [A]	/	864	/	864
Power cells				
Number of cells per phase	9		9	
Power cell rated current [A]	720		720	
Power cell current with 120 %overload 1 min / 10 min [A]	864		864	
Max. output current for 3 sec [A]	1080		1080	
Characteristics with standard efficiency				
Efficiency at 100 % load (incl. Transformer) [%]	96.5%		96.5%	
Total losses at 100 % load [kW]	378.4	347.0	433.8	347.0
Air flow [m³/h]	110542		110542	
Noise level [dB (A)] @ 50 Hz	85		85	
Weight [kg / lb]	30750/67650		33102/72824	
Dimension [mm / inch] W*D*H 2)	15660*1800*3155/ 617.1*71*124.4		15660*1800*3155/ 617.1*71*124.4	
Connection				
Incoming cable type	symmetrical three-phase		symmetrical three-phase	
Typical cable size (mm² / AWG) 3)	120*2/2*0000		150*2/2*300MCM	
Motor cable type	symmetrical three-phase(Use of shielded cable is advisable)		symmetrical three-phase(Use of shielded cable is advisable)	
Typical cable size (mm² / AWG) 3)	120*2/2*0000		150*2/2*300MCM	
Motor cable Max. length 4)	1000 m		1000 m	
Grounding connection PE (mm² / AWG)	120/0000		120/0000	
Control power supply	single phase, 230V, 50/60Hz,		single phase, 230V, 50/60Hz,	
Capacity of control power supply w/o options	1 kVA		1 kVA	
Capacity of control power supply with options	"depending on options to be used"		"depending on options to be used"	
Fan power supply	3-phase 400 Vac, 50Hz		3-phase 400 Vac, 50Hz	
Capacity of fan power supply (kVA) 5)	70		70	
Maintenance				
Maintenance access	Front & Rear		Front & Rear	
Cable entry 6)	Bottom in /Bottom out		Bottom in /Bottom out	
1) Values valid for synchronous motor and asynchronous motor. The specifications for the maximum motor shaft power is based on a motor efficiency of 95%. 2) Including the height of top cooling fans. 3) For CE products: Typical cable size values based on use of copper cables in cable tray laying. Incoming cable size is based on drive current rating. It has to be checked to be in accordance to mains short circuit capability and local and national electrical code requirement as well all other applicable regulations. 4) Variation in max. cable length may be possible depending on type cable and installation. For longer cable length between motor and drive contact Schneider Electric. 5) Contact Schneider Electric if N+1 redundancy cooling fan requested. 6) For other combination contact Schneider Electric.				

ATV6000M159A1111...ATV6000M188A1111

ATV6000	ATV6000M159A1111NA●		ATV6000M170A1111NA●	
Nominal data	Normal Duty	Heavy Duty	Normal Duty	Heavy Duty
Type rating [kVA]	15900		17000	
Max. Motor power [kW] / [HP] 1)	12700/17030	10830/14523	13530/18144	10830/14523
Nominal Continuous output current [A] 1)	797	680	850	680
Max. output current with 120 %overload 1 min / 10 min [A]	957	/	1020	/
Max. output current with 150 % overload 1 min / 10 min [A]	/	1020	/	1020
Power cells				
Number of cells per phase	9		9	
Power cell rated current [A]	850		850	
Power cell current with 120 %overload 1 min / 10 min [A]	1020		1020	
Max. output current for 3 sec [A]	1275		1275	
Characteristics with standard efficiency				
Efficiency at 100 % load (incl. Transformer) [%]	96.5%		96.5%	
Total losses at 100 % load [kW]	480.6	409.9	512.0	409.9
Air flow [m ³ /h]	114214		114214	
Noise level [dB (A)] @ 50 Hz	85		85	
Weight [kg / lb]	35978/79152		37340/82148	
Dimension [mm / inch] W*D*H 2)	15660*1800*3455/ 617.1*71*136.2		15660*1800*3455/ 617.1*71*136.2	
Connection				
Incoming cable type	symmetrical three-phase		symmetrical three-phase	
Typical cable size (mm ² / AWG) 3)	185*2/2*350MCM		240*2/2*500MCM	
Motor cable type	symmetrical three-phase(Use of shielded cable is advisable)		symmetrical three-phase(Use of shielded cable is advisable)	
Typical cable size (mm ² / AWG) 3)	240*2/2*500MCM		240*2/2*500MCM	
Motor cable Max. length 4)	1000 m		1000 m	
Grounding connection PE (mm ² / AWG)	150/300MCM		150/300MCM	
Control power supply	single phase, 230V, 50/60Hz,		single phase, 230V, 50/60Hz,	
Capacity of control power supply w/o options	1 kVA		1 kVA	
Capacity of control power supply with options	"depending on options to be used"		"depending on options to be used"	
Fan power supply	3-phase 400 Vac, 50Hz		3-phase 400 Vac, 50Hz	
Capacity of fan power supply (kVA) 5)	83		83	
Maintenance				
Maintenance access	Front & Rear		Front & Rear	
Cable entry 6)	Bottom in /Bottom out		Bottom in /Bottom out	

ATV6000	ATV6000M188A1111NA●		ATV6000M199A1111NA●	
Nominal data	Normal Duty	Heavy Duty	Normal Duty	Heavy Duty
Type rating [kVA]	18800		19900	
Max. Motor power [kW] / [HP] 1)	15000/20115	12740/17084	15920/21349	12740/17084
Nominal Continuous output current [A] 1)	942	800	1000	800
Max. output current with 120 %overload 1 min / 10 min [A]	1130	/	1200	/
Max. output current with 150 % overload 1 min / 10 min [A]	/	1200	/	1200
Power cells				
Number of cells per phase	9		9	
Power cell rated current [A]	1000		1000	
Power cell current with 120 %overload 1 min / 10 min [A]	1200		1200	
Max. output current for 3 sec [A]	1500		1500	
Characteristics with standard efficiency				
Efficiency at 100 % load (incl. Transformer) [%]	96.5%		96.5%	
Total losses at 100 % load [kW]	567.7	482.2	602.5	482.2
Air flow [m³/h]	114214		114214	
Noise level [dB (A)] @ 50 Hz	85		85	
Weight [kg / lb]	39745/87439		41107/90435	
Dimension [mm / inch] W*D*H 2)	15660*1800*3455/ 617.1*71*136.2		15660*1800*3455/ 617.1*71*136.2	
Connection				
Incoming cable type	symmetrical three-phase		symmetrical three-phase	
Typical cable size (mm² / AWG) 3)	240*2/2*500MCM		120*3/3*0000	
Motor cable type	symmetrical three-phase(Use of shielded cable is advisable)		symmetrical three-phase(Use of shielded cable is advisable)	
Typical cable size (mm² / AWG) 3)	240*2/2*500MCM		240*2/2*500MCM	
Motor cable Max. length 4)	1000 m		1000 m	
Grounding connection PE (mm² / AWG)	185/350MCM		185/350MCM	
Control power supply	single phase, 230V, 50/60Hz,		single phase, 230V, 50/60Hz,	
Capacity of control power supply w/o options	1 kVA		1 kVA	
Capacity of control power supply with options	"depending on options to be used"		"depending on options to be used"	
Fan power supply	3-phase 400 Vac, 50Hz		3-phase 400 Vac, 50Hz	
Capacity of fan power supply (kVA) 5)	83		83	
Maintenance				
Maintenance access	Front & Rear		Front & Rear	
Cable entry 6)	Bottom in /Bottom out		Bottom in /Bottom out	
1) Values valid for synchronous motor and asynchronous motor. The specifications for the maximum motor shaft power is based on a motor efficiency of 95%. 2) Including the height of top cooling fans. 3) For CE products: Typical cable size values based on use of copper cables in cable tray laying. Incoming cable size is based on drive current rating. It has to be checked to be in accordance to mains short circuit capability and local and national electrical code requirement as well all other applicable regulations. 4) Variation in max. cable length may be possible depending on type cable and installation. For longer cable length between motor and drive contact Schneider Electric. 5) Contact Schneider Electric if N+1 redundancy cooling fan requested. 6) For other combination contact Schneider Electric.				

Layout Drawing and Dimensions

Layout Drawing

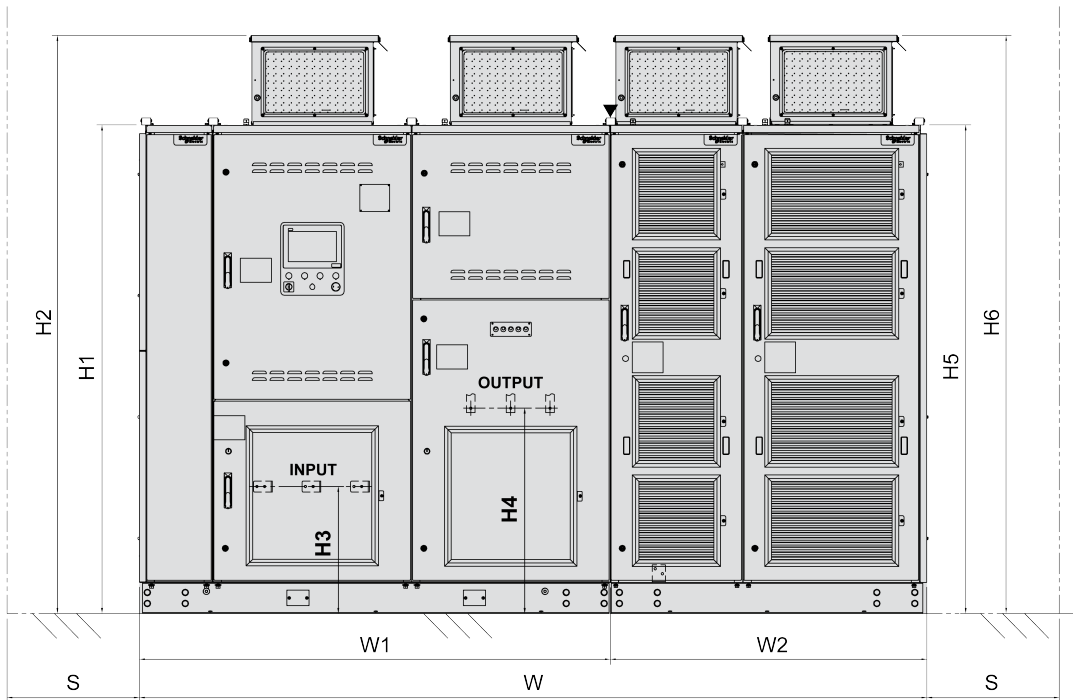

INPUT: Input terminal

OUTPUT: Output terminal

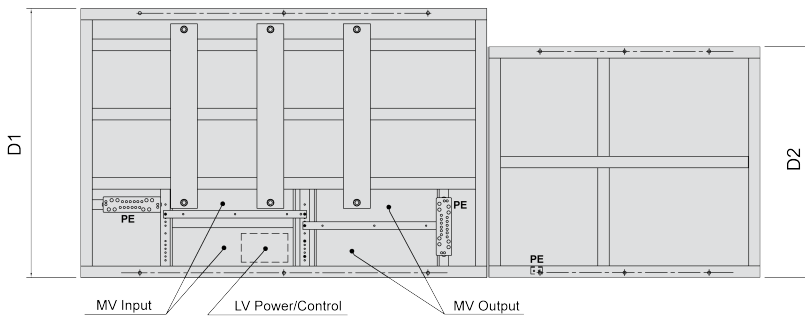

MV Input: MV Input cable area

LV Power/Control: LV Power/Control cable area

MV Output: MV Output cable area

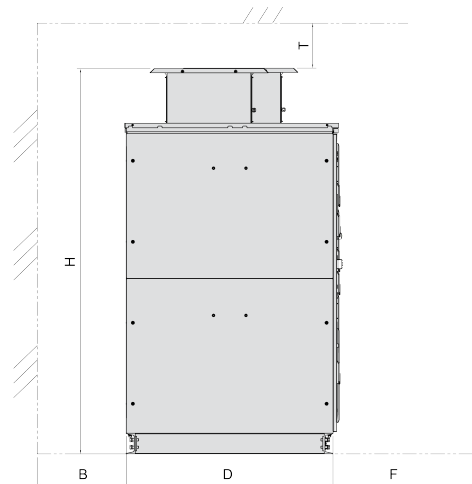

NOTE: Sketch is representing outline dimensions only, real cabinet arrangement is depending on power size.

Main dimensions - Output Voltage 11 kV

Product reference	Outer dimensions (mm / in)			Transformer cabinet			Powercell cabinet		
	W	H ^(b)	D	Fan Type	Fan Number	Weight [kg / lb]	Fan Type	Fan number	Weight [kg / lb]
ATV6000D500A1111...	3860	2754	1600	450	2	2571.7	450	2	1468.9
	152	108	63			5657.7			3231.6
ATV6000D690A1111...	3860	2754	1600	450	2	2806.9	450	2	1468.9
	152	108	63			6175.2			3231.6
ATV6000D790A1111...	4160	2754	1600	450	3	3058.3	450	2	1468.9
	164	108	63			6728.3			3231.6
ATV6000C100A1111...	4160	2754	1600	450	3	3318.3	450	2	1468.9
	164	108	63			7300.3			3231.6
ATV6000C129A1111...	4160	2754	1600	450	3	3677.3	450	2	1468.9
	164	108	63			8090.1			3231.6
ATV6000C150A1111...	4160	2754	1600	450	3	3937.3	450	2	1468.9
	164	108	63			8662.1			3231.6
ATV6000C175A1111...	4160	2754	1600	450	3	4246.8	450	2	1468.9
	164	108	63			9343			3231.6
ATV6000C199A1111...	4160	2754	1600	450	3	4544	450	2	1468.9
	164	108	63			9996.8			3231.6
ATV6000C225A1111...	5160	2795	1700	450	3	4898.5	560	3	2563.9
	203	110	67			10776.7			5640.6
ATV6000C250A1111...	5460	2795	1700	450	3	5240	560	3	2746.1
	215	110	67			11528			6041.4
ATV6000C298A1111...	5460	2795	1700	450	3	5834.3	560	3	2746.1
	215	110	67			12835.5			6041.4
ATV6000C325A1111...	6660	2754	1700	450	3	6168.6	400	5	3681.7
	262	108	67			13570.9			8099.7
ATV6000C375A1111...	6660	2754	1700	450	3	6787.6	400	5	3681.7
	262	108	67			14932.7			8099.7
ATV6000C438A1111...	6960	3155	1800	560	3	8101.7	400	5	3681.7
	274	124	71			17823.7			8099.7
ATV6000C557A1111...	7460	3155	1800	560	3	9689.7	560	5	3914.1
	294	124	71			21317.3			8611
ATV6000C637A1111...	9460	3155	1800	560	4	10815.3	400	9	6479
	372	124	71			23793.7			14253.8
ATV6000C713A1111...	9460	3155	1800	560	4	11756.3	400	9	6479
	372	124	71			25863.9			14253.8
ATV6000C817A1111...	9460	3155	1800	560	4	13043.9	400	9	6479
	372	124	71			28696.6			14253.8
ATV6000C888A1111...	9460	3155	1800	560	4	13922.9	450	9	6447.4
	372	124	71			30630.4			14184.3
ATV6000C975A1111...	9460	3155	1800	560	4	15000	450	9	6447.4
	372	124	71			33000			14184.3

Product reference	Outer dimensions (mm / in)			Transformer cabinet			Powercell cabinet		
	W	H ^(b)	D	Fan Type	Fan Number	Weight [kg / lb]	Fan Type	Fan number	Weight [kg / lb]
ATV6000M110A1111... ^(a)	15060	3155	1800	560	3	18446.3	500	9	10175.9
	593	124	71			40581.9			22387
ATV6000M125A1111... ^(a)	15660	3155	1800	560	4	20573.7	500	9	10175.9
	617	124	71			45262.1			22387
ATV6000M144A1111... ^(a)	15660	3155	1800	560	4	22926	500	9	10175.9
	617	124	71			50437.2			22387
ATV6000M159A1111... ^(a)	15660	3455	1800	560	4	25616	560	9	10361.3
	617	136	71			56355.2			22794.9
ATV6000M170A1111... ^(a)	15660	3455	1800	560	4	26977.9	560	9	10361.3
	617	136	71			59351.4			22794.9
ATV6000M188A1111... ^(a)	15660	3455	1800	560	4	29190.3	560	9	10554.4
	617	136	71			64218.7			23219.7
ATV6000M199A1111... ^(a)	15660	3455	1800	560	4	30552.1	560	9	10554.4
	617	136	71			67214.6			23219.7

a) "W" is linked to dual transformer cabinets.

b) "H" is linked to higher size of transformer cabinet (H2) or power cell cabinet (H6).

Additional Dimensions - Output Voltage 11 kV

Product reference	Transformer Cabinet						Power cell Cabinet				Space Maintenance			
	(mm / in)						(mm / in)				(mm / in)			
	H1	H2	H3	H4	W1	D1	H5	H6	W2	D2	T	B (a)	F (b)	S (c)
ATV6000D500A1111...	2360 93	2754 108	500 20	930 37	2130 84	1600 63	2360 93	2754 108	1730 68	1200 47	≥500 ≥20	0	1500 59	0
ATV6000D690A1111...	2360 93	2754 108	500 20	930 37	2130 84	1600 63	2360 93	2754 108	1730 68	1200 47	≥500 ≥20	0	1500 59	0
ATV6000D790A1111...	2360 93	2754 108	500 20	930 37	2430 96	1600 63	2360 93	2754 108	1730 68	1200 47	≥500 ≥20	0	1500 59	0
ATV6000C100A1111...	2360 93	2754 108	500 20	930 37	2430 96	1600 63	2360 93	2754 108	1730 68	1200 47	≥500 ≥20	0	1500 59	0
ATV6000C129A1111...	2360 93	2754 108	500 20	930 37	2430 96	1600 63	2360 93	2754 108	1730 68	1200 47	≥500 ≥20	0	1500 59	0
ATV6000C150A1111...	2360 93	2754 108	500 20	930 37	2430 96	1600 63	2360 93	2754 108	1730 68	1200 47	≥500 ≥20	0	1500 59	0
ATV6000C175A1111...	2360 93	2754 108	500 20	930 37	2430 96	1600 63	2360 93	2754 108	1730 68	1200 47	≥500 ≥20	0	1500 59	0
ATV6000C199A1111...	2360 93	2754 108	500 20	930 37	2430 96	1600 63	2360 93	2754 108	1730 68	1200 47	≥500 ≥20	0	1500 59	0
ATV6000C225A1111...	2360 93	2754 108	500 20	930 37	2430 96	1700 67	2360 93	2795 110	2730 107	1200 47	≥500 ≥20	0	1500 59	0
ATV6000C250A1111...	2360 93	2754 108	500 20	930 37	2730 107	1700 67	2360 93	2795 110	2730 107	1200 47	≥500 ≥20	≥600 ≥24	1500 59	0
ATV6000C298A1111...	2360 93	2754 108	500 20	930 37	2730 107	1700 67	2360 93	2795 110	2730 107	1200 47	≥500 ≥20	≥600 ≥24	1500 59	0
ATV6000C325A1111...	2360 93	2754 108	500 20	930 37	2730 107	1700 67	2360 93	2690 106	3930 155	1200 47	≥500 ≥20	≥600 ≥24	1500 59	0
ATV6000C375A1111...	2360 93	2754 108	500 20	930 37	2730 107	1700 67	2360 93	2690 106	3930 155	1200 47	≥500 ≥20	≥600 ≥24	1500 59	0
ATV6000C438A1111...	2720 107	3155 124	560 22	1290 51	3030 119	1800 71	2420 95	2750 108	3930 155	1200 47	≥500 ≥20	≥600 ≥24	1500 59	0
ATV6000C557A1111...	2720 107	3155 124	560 22	1290 51	3330 131	1800 71	2420 95	2855 112	4130 163	1200 47	≥500 ≥20	≥600 ≥24	1500 59	0
ATV6000C637A1111...	2720 107	3155 124	560 22	1290 51	3630 143	1800 71	2420 95	2750 108	5830 230	1200 47	≥500 ≥20	≥600 ≥24	1500 59	0
ATV6000C713A1111...	2720 107	3155 124	560 22	1290 51	3630 143	1800 71	2420 95	2750 108	5830 230	1200 47	≥500 ≥20	≥600 ≥24	1500 59	0
ATV6000C817A1111...	2720 107	3155 124	560 22	1290 51	3630 143	1800 71	2420 95	2750 108	5830 230	1200 47	≥500 ≥20	≥600 ≥24	1500 59	0
ATV6000C888A1111...	2720 107	3155 124	560 22	1290 51	3630 143	1800 71	2420 95	2814 111	5830 230	1200 47	≥500 ≥20	≥600 ≥24	1500 59	0
ATV6000C975A1111...	2720 107	3155 124	560 22	1290 51	3630 143	1800 71	2420 95	2814 111	5830 230	1200 47	≥500 ≥20	≥600 ≥24	1500 59	0

Product reference	Transformer Cabinet (mm / in)						Power cell Cabinet (mm / in)				Space Maintenance (mm / in)			
	H1	H2	H3	H4	W1	D1	H5	H6	W2	D2	T	B (a)	F (b)	S(c)
ATV6000M110A1111...	2720 107	3155 124	560 22	1290 51	3330 131	1800 71	2420 95	2828 111	8430 332	1400 55	≥500 ≥20	≥600 ≥24	1500 59	0
ATV6000M125A1111...	2720 107	3155 124	560 22	1290 51	3630 143	1800 71	2420 95	2828 111	8430 332	1400 55	≥500 ≥20	≥600 ≥24	1500 59	0
ATV6000M144A1111...	2720 107	3155 124	560 22	1290 51	3630 143	1800 71	2420 95	2828 111	8430 332	1400 55	≥500 ≥20	≥600 ≥24	1500 59	0
ATV6000M159A1111...	3020 119	3455 136	560 22	1590 63	3630 143	1800 71	2420 95	2855 112	8430 332	1400 55	≥500 ≥20	≥600 ≥24	1500 59	0
ATV6000M170A1111...	3020 119	3455 136	560 22	1590 63	3630 143	1800 71	2420 95	2855 112	8430 332	1600 63	≥500 ≥20	≥600 ≥24	1500 59	0
ATV6000M188A1111...	3020 119	3455 136	560 22	1590 63	3630 143	1800 71	2420 95	2855 112	8430 332	1600 63	≥500 ≥20	≥600 ≥24	1500 59	0
ATV6000M199A1111...	3020 119	3455 136	560 22	1590 63	3630 143	1800 71	2420 95	2855 112	8430 332	1600 63	≥500 ≥20	≥600 ≥24	1500 59	0

a) Space could be required for installation and lifting lugs.
b) For easy handling with power cell exchange tool 2000mm (78.7 in) are recommended.
c) Space (600mm) could be required for maintenance of the front & rear access drive.

Options

Available Options

To enlarge the scope of application, various options are available concerning ATV6000.

General enclosure options		
Allocation table options		
Options (1)	Brief description	Option code
Communication buses and networks (2)		
CANopen RJ45 Daisy chain	Fieldbus module for control of the inverter via CANopen Daisy Chain.	CP07
CANopen SUB-D	Fieldbus module for control of the inverter via CANopen with SUB-D port.	CP09
CANopen Screw terminal block	Fieldbus module for control of the inverter via CANopen with screw terminals.	CP08
EtherCAT	Fieldbus module for control of the inverter via EtherCAT Daisy Chain.	CP06
PROFINET	Fieldbus module for control of the inverter via PROFINET.	CP05
PROFIBUS DP V1	Fieldbus module for control of the inverter via Profibus DP V1.	CP03
DeviceNet	Fieldbus module for control of the inverter via DeviceNet.	CP04
I/O Extension Modules (2)		
Additional analog outputs (4AO - PLC Card)	PLC module providing additional 4 analog outputs.	A11
Digital and analog I/O	Option module providing additional analog and digital inputs and outputs. (6 digital inputs, 2 digital outputs, 2 analog inputs)	A61
Relay outputs	Option module providing three additional relay outputs.	A62
Encoder Interface Modules (2)		
Resolver encoder	Encoder module for connecting a resolver.	EO01
Encoder with digital output	Encoder module for connecting a digital encoder.	EO02
Encoder with analog output	Encoder module for connecting an analog encoder.	EO03
HTL encoder interface	Encoder module for connecting a HTL encoder.	EO04
Output filters		
Dv/dt filters	Contact your local Schneider Electric representative.	OF01
Sinus filters	Contact your local Schneider Electric representative.	OF02
Power supply		
60 Hz design	The drive is designed with electrical adaptation (60 Hz top cooling fans + 60 Hz integrated transformer). .	A09
Cooling fan powered by internal transformer	A shielded 400 V windings is added to the MV transformer in order to supply the cooling fans. In this case, the customer do not need to provide the fan power supply.	A63
UPS	UPS with around 10 min autonomy (depends option) for the control power.	A60
Wiring		
Motor thermal monitoring 8 x Pt100	The drive allows monitoring of the motor windings temperature (6 x Pt100) and the bearing temperature of motor (2 x Pt100).	A08
Analog isolator for one signal	The analog isolator helps prevent interference of signals. This option can be selected several times depending on number of signals used.	A13
Ethernet Port on Front Door	The Ethernet port in the enclosure door allows access to the frequency inverter via Ethernet without opening the enclosure door. The plug provides a dust protection cap.	A65

General enclosure options		
Allocation table options		
Options (1)	Brief description	Option code
Switch "Remote / Panel / Local - Control"	The switch "Remote / Panel / Local - Control" allows to switch between remote operation (via terminals or bus), panel operation (via HMI) or local operation (next to motor).	A66
Cable entry (top in/ top out)	Additional cabinet to achieve power/control cable entry and exit from the top.	BE01
Cable entry (top in/ bottom out)	Additional cabinet to achieve power/control cable entry from the top and power/control exit from the bottom.	BE02
Feeder for motor space heater	Additional contactor for controlling motor space heater.	E00
Safety Function or Power Output Enable function		
Removal of mains voltage off button	Mains voltage off button is mounted by default with the product. It is possible to remove this part from door HMI Panel. NOTE: The safety function (STO) or power enable function (POE) is still implemented even if this button is removed.	A64
Safe Torque Off (STO) SIL2 Stop Category 0 (on terminals)	The drive is designed with Safe Torque Off (STO) feature with SIL2 stop category 0 on terminals. (Not compatible with SP07 option, and with Power Off Enable features)	SP06
Safe Stop 1 (SS1) SIL2 Stop Category 1 (on terminals)	The drive is designed with Safe Torque Off (STO) feature with Safe Stop 1 (SS1) SIL2 Stop Category 1 on terminals. (Not compatible with SP06 option, and with Power Off Enable features)	SP07
Environment and general technical data		
Input Short-circuit Current Rating 31.5 kA/1s	Input section is reinforced to withstand high short circuit current.	E04
Seismic	ATV6000 has been adapted with a reinforced cabinet design to handle levels equal or below UBC4 at ground level. Validated by simulation. Contact Schneider Electric for equivalence with local code/regulation.	E07
High altitude >1000 m	For higher altitudes >1000 m, up to 2000 m is possible with derating. Above 2000 m contact your local Schneider Electric representative.	E08
Drive Efficiency = 96.5 % >96 %	Increase the ATV6000 efficiency from 96 % to 96.5 % by increasing the transformer efficiency from 98 % to 98.5 %.	E10
Maximum Ambient Temperature > 40 °C	For higher indoor maximum ambient temperature >40 °C, up to 50 °C is possible with derating.	E11
Cabinet and transformer		
Transformer Winding Selection Copper	Copper Winding for the internal power transformer.	A67
Reactor cabinet for synchronous bypass	An output reactor is needed for the decoupling of VSD output during the synchronous bypass process. Synchronous bypass is done automatically with one or multiple motors. For switchgear selection and process definition contact your local Schneider Electric representative.	BCS10
Inrush current limit cabinet	For a weak network is possible to limit the Inrush current up to 1.6 nominal input current caused by the internal power transformer. Typical values for ATV6000 are $I_{inrush} = [8 \text{ to } 14] \times \sqrt{2} \times I_{input_RMS}$ with a time constant limited to 80 to 120ms.	IL01
Harsh environment		
Humidity	The drive is designed to run in an environment with a relative humidity of up to 95% (non-condensing).	E01
Cabinet Space heater	The drive is equipped with a thermostat and a circuit breaker to energize an anti-condensation space heater independent if drive is running or not. The space heaters will be connected to the auxiliary power supply. Power for the space heaters need to be provided by the customer.	A06
Cooling fan redundancy	N+1 fans adapted for transformer and power cell cabinets respectively, each fan is equipped with shutter. in case of one fan is inoperative, its shutter is close to avoid short-cut of air flow, meanwhile the redundant fan is switched in by the drive controller. It helps to prevent production downtime or unplanned interruption. Replacement of the inoperative fan can be arranged at the next scheduled maintenance.	E03

General enclosure options		
Allocation table options		
Options (1)	Brief description	Option code
Optimized fan redundancy	The top fan's size is adapted for transformer and power cell cabinets, and fans are equipped with an electric actuator and shutter, keeping standard dimensions (which is reduced compared to N+1 fan (E03)) . Contact your local Schneider Electric representative for details.	E06
Air duct	Cooling with air duct channel optimizes the design of the air conditioning system. Clean air has to be provided to the drive air inlets.	A01
Protection level IP31	The standard design of the ATV6000 enclosure unit complies with protection degree IP31. If a higher protection degree is desired or required, there are two alternative solutions available, IP41 and IP42.	SP02
Protection level IP41		SP03
Protection level IP42		SP04
Guarding options		
QF1 MCVB interlock compatibility box	This provides sequential control between the QF1 Medium Voltage Circuit Breaker (QF1 MCVB) key and the "Free key" of VSD.	A02
Grounding cable for maintenance	3 poles earthing and short circuiting device in accordance with IEC 61230.	A07
Power cell bypass	The drive (up to 490A) is designed with Power cell bypass feature.	PC01
Inverter Redundancy (N+1)	The inverter redundancy configuration (N+1) offer more availability on the process/application with 100% load capability. Power cell bypass function is embedded in each power cell. Inverter redundancy (N+1) is available up to 490 A.	PC02
Inverter Redundancy (N+2)	The inverter redundancy configuration (N+2) offer more availability on the process/application with 100% load capability. Power cell bypass function is embedded in each power cell. Inverter redundancy (N+2) is available up to 490 A.	PC03
VAMP Arc flash detection	The VAMP arc detection system is an easily adaptable arc detection system for detection and monitoring of electricity distribution systems.	E02
Customization		
Cabling color	Customized power and control color cables for identification.	A50
Cabinet color	Customized cabinet color according to a RAL, on request.	CC01
EcoStruxure Asset Advisor (2)		
EAA connectivity	The ATV6000 with EcoStruxure Asset Advisor transforms data into insight to help run your operations more efficiently and safer, with more availability, and increased profits.	E05
<p>(1) For more details, see next pages or contact your local Schneider Electric representative.</p> <p>(2) Depending on the option selected, only two slot modules can be used for the Fieldbus module, IO Extension modules, and Encoder Interface modules.</p> <p>NOTE: For High Altitude: ≤1000m, up to 2000m possible with derating. Above 2000m contact your local Schneider Electric representative.</p> <p>For all other requests not mentioned in the list above, contact your local Schneider Electric representative.</p>		

Communication Buses and Networks

Presentation

Altivar Process drives have 3 built-in RJ45 communication ports as standard:

- 1 EtherNet/IP and Modbus TCP dual port
- 1 serial port

Integrated communication protocols

Altivar Process drives integrate the EtherNet/IP and Modbus TCP and Modbus serial link communication protocols as standard.

- EtherNet/IP and Modbus TCP dual port

This offers standard services regularly used in industrial networks: Connection to the Modbus TCP or EtherNet/IP network

- EtherNet IP adapter including standard CIP objects (AC/DC drive objects, CIP energy objects, etc.), compliant to ODVA specification
- The RSTP connection allows ring topology to help ensure continuity of service.
- Dual port allows daisy chain connection to simplify cabling and network infrastructure (no need to use a switch).
- Modbus TCP message handling is based on the Modbus protocol and is used to exchange process data with other network devices (e.g., a PLC). It provides Altivar Process drives with access to the Modbus protocol and to the high performance of the Ethernet network, which is the communication standard for numerous devices.
- SNMP (Simple Network Management Protocol) offers standard diagnostics services for network management tools.
- The FDR (Fast Device Replacement) service allows automatic reconfiguration of a new device installed to replace an existing device.
- Device integrity is reinforced by disabling some unused services as well as managing a list of authorized devices.
- Setup and adjustment tools (SoMove, Unity with DTM) can be connected locally or remotely.
- The embedded Web server is used to display operating data, dashboards and perform systems elements diagnostics from any web browser.

These numerous services offered by Altivar Process drives simplify integration into Schneider Electric process automation control systems like M580 ePAC or Foxboro Evo DCS.

- Serial port
 - Field network operation for exchanging data with other devices via the Modbus protocol
 - Multidrop connection of the following HMIs and configuration tools:
 - A Magelis industrial HMI terminal
 - A PC with SoMove or Unity setup software

The detailed specifications for the EtherNet/IP or serial communication ports, and the Modbus and Modbus TCP protocols are available on our website www.se.com.

Modules



CANopen Daisy chain module



CANopen SUB-D module



CANopen module, screw terminal block



PROFINET module



PROFIBUS DP V1 module

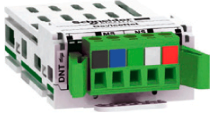

DeviceNet module, 5-way screw connector



EtherCAT module

Optional fieldbus modules

The Altivar Process drive can also be connected to other industrial fieldbuses and networks by using one of the fieldbus modules available as an option. Fieldbus modules are supplied in "cassette" format for ease of mounting/removal.

Dedicated fieldbus modules:

- CANopen:
 - RJ45 Daisy Chain
 - Sub-D
 - Screw terminal block
- EtherCAT
- PROFINET
- PROFIBUS DP V1
- DeviceNet

PROFINET and PROFIBUS DP V1 modules also support the Profidrive and CiA402 profiles.

It is possible to maintain communication using a separate power supply for the control and power sections. Monitoring and diagnostics via the network are possible even if there is no power supplied to the power section.

Functions

The drive functions can be accessed via the various communication networks:

- Configuration
- Adjustment
- Control
- Monitoring

Altivar Process drives offer a high degree of interfacing flexibility with the possibility to assign, by configuration, the different control sources (I/O, communication networks, and HMI terminal) to control functions in order to meet the requirements of complex applications.

Network services and parameters are configured using the SoMove drive setup software, or using

Communication is monitored according to the specific criteria for each protocol. However, regardless of the protocol, it is possible to configure how the drive responds to a detected communication interruption, as follows:

- Define the type of stop when a communication interruption is detected
- Maintain last command received
- Fallback position at preset speed
- Ignore the detected communication interruption

I/O Extension Modules

Presentation

By installing I/O extension modules Altivar Process drives can be adapted to meet the needs of applications that manage additional sensors or specific sensors.

2 extension modules are available:

- Module with digital and analog I/O
- Module with relay outputs



Digital and analog I/O module

Module with digital and analog I/O

- 2 differential analog inputs configurable via software as current (0-20 mA / 4-20 mA), or for PTC, PT100, or PT1000, 2 or 3-wire
14-bit resolution
- 6 x 24 Vdc positive or negative digital inputs
Sampling: 1 ms max
- 2 assignable digital outputs
- 2 removable spring terminal blocks



Relay outputs module

Module with relay outputs

- 3 relay outputs with NO contacts
- 1 fixed screw terminal block

NOTE: Digital and analog I/O modules and relay output modules can go in either slot A or slot B on Altivar Process drives. However, the drives cannot take 2 modules of the same type (e.g., 2 digital and analog I/O modules or 2 relay output modules).

Encoder Interface Modules

Encoder



Digital interface encoder module



Analog interface encoder module



Resolver interface module



HTL encoder interface module

Presentation

Encoder interface modules are used for Flux Vector Control operation with sensor (FVC mode) for asynchronous motors, or for Vector Control operation with speed feedback (FSY mode) for synchronous motors. They improve drive performance during demanding motor load states:

- Zero speed torque
- Accurate speed regulation
- Torque accuracy
- Shorter response times on a torque surge
- Improved dynamic performance in transient state

For asynchronous motors, in the other control modes (voltage vector control, voltage/frequency ratio), encoder interface modules improve static speed accuracy.

Depending on the model, encoder interface modules can also be used for monitoring, irrespective of the control type:

- Overspeed detection
- Load slipping detection

They can also transmit a reference value provided by the encoder input to the Altivar variable speed drive. This specific feature is used to synchronize the speed of several drives. The encoder options have a thermal sensor input to monitor one standard temperature sensor.

4 modules are available depending on the encoder technology:

- Resolver encoder
- Encoder with digital output
- Encoder with analog output
- HTL encoder interface

The Altivar variable speed drive can only be equipped with one of the encoder interface modules. The interface encoder module is inserted in a dedicated slot. It is designed to help protect against encoder supply short circuits and overloads.

Output Filters

Option: dv/dt Filters (OF01)

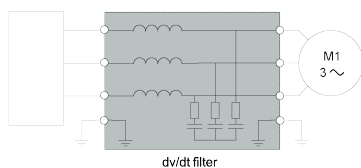

Altivar Process drive with dv/dt filter

Presentation

Altivar Process ATV6000 drives operate with the following maximum motor cable lengths as standard:

Up to 1.000m (3.280 ft) depending on cable type and laying.

It is advisable to use dv/dt filters for the following applications:

- Motor cable length is exceeding the above limits for direct connection
- Reduce stress of motor isolation

Contact your local Schneider Electric representative.

Option: Sinus Filters (OF02)

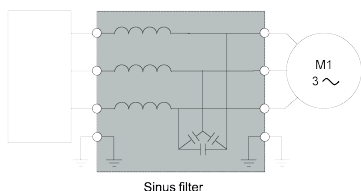

Altivar Process drive with sinus filter

Presentation

Altivar Process ATV6000 drives operate with the following maximum motor cable lengths as standard:

Up to 1.000m (3.280 ft) depending on cable type and laying.

Contact your local Schneider Electric representative.

Application

it is advisable to use sinus filters for the following applications:

- Motor cable length is exceeding the above limits for direct connection
- Quality of motor isolation is not known
- Reduction of EMC influence
- Submersible pumps sensitive to dv/dt and Upeak

Power Supply

60 Hz Design (A09)

The drive is designed with electrical adaptation (60 Hz top cooling fans + 60 Hz integrated transformer).

Cooling Fan Powered by Internal Transformer (A63)

A shielded 400 V windings is added to the MV transformer in order to supply the cooling fans. In this case, the customer does not need to provide the fan power supply.

Uninterrupted Power Supply (UPS) (A60)



The auxiliary control supply voltage should be provided as uninterrupted power supply. This is important to keep the electronics part of the drive operative, even the other voltages are not available.

In case the auxiliary control supply voltage is not provided with uninterrupted power supply, the UPS option can secure control part stay operative. This is e.g. important for fieldbus communication.

Benefits:

- UPS keep the control electronic operative
- Fieldbus communication is not interrupted, and data exchange is granted
- Autonomy is provided for around 10 minutes (depends on the options)

Wiring

Cable Entry: Top in / Top Out (BE01)

Additional cabinet to achieve power/control cable entry and exit from the top.



Cable Entry: Top in/ Bottom Out (BE02)

Additional cabinet to achieve power/control cable entry from the top and power/control exit from the bottom.



Analog Isolator (A13)



The analog isolator helps prevent interference of signals. This option can be selected several times depending on number of signals used..

Ethernet Port on Front Door (A65)

The Ethernet port in the enclosure door allows access to the frequency inverter via Ethernet without opening the enclosure door. The plug provides a dust protection cap.



Switch "Remote / Panel / Local - Control" (A66)

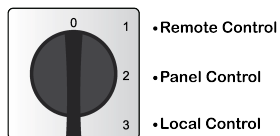

The switch "Remote / Panel / Local - Control" allows to switch between remote operation (via terminals or bus), panel operation (via HMI) or local operation (next to motor).

Feeder for Motor Space Heater (E00)

Additional contactor for controlling motor space heater.

Safety Function or Power Output Enable function

Selection

The drive supports the **Safe Torque Off (STO)** function or **Power Output Enable (POE)** function which as one of the ways to prevent unexpected startups.

From software version 2.0, the drive supports the **Safe Torque Off (STO)** function according to the IEC 61800-5-2 standard (defined in section 4.2.2.2). All details related to the STO safety function activation are given in the ATV6000 Embedded Safety Function Manual BQT43422.

- This function will activate STO (SIL2) using the embedded safety relay.
- When STO option is selected, drive bypass option cannot be used, as bypass switch is not compliant with SIL2.
- When STO option is selected, a minimum of 3 PoC per phase in operation is mandatory.
- The STO option is dependent on altitude constraints. Refer to the "Maximum PoC admissible" given in the ATV6000 Embedded Safety Function Manual BQT43422.

Power Output Enable (POE) function has not been qualified per any safety standard.

- The embedded safety relay circuit is present and allows POE to be triggered, however this safety relays is not compliant with SIL2.
- When POE option is selected, drive bypass option can be used.
- When POE option is selected, operation with less than 3 PoC per phase is possible.
- When POE option is selected, the standard is not applied.

NOTE: To check which type of function is present with your system, refer to the Master Controller Identification, page 47.

Mains Off Button

For **Safe Torque Off (STO)**: This mains Off button is available in the enclosure door (to the HMI Panel) performing STO and mains Off, and there is a possibility to connect additional mains off button on XT60 terminal (STO).

For **Power Output Enable (POE)**: This mains Off button is available in the enclosure door (to the HMI Panel), and there is a possibility to connect additional mains off button on XT11 terminal (POE).

NOTE: The Safe Torque Off (STO) function or Power Output Enable (POE) function is still implemented even if this mains Off button is removed.

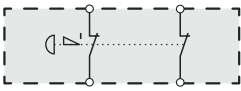
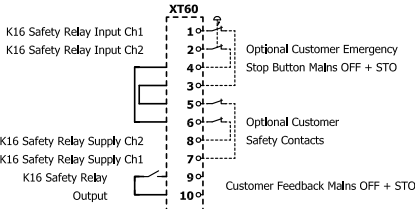
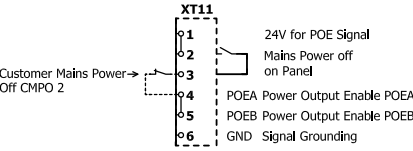
Mains off button in the enclosure door (1)	Customer terminal XT60 – STO (1)	Customer terminal XT11 – POE
		

(1) For all certified architecture refer to the ATV6000 Embedded Safety Function Manual BQT43422 (Refer to the case 1...3).

Safe Torque Off (STO) SIL2 Stop Category 0 (on terminals) (SP06)

The drive is designed with Safe Torque Off (STO) feature with SIL2 stop category 0 on terminals (Customer terminal XT11).

The drive incorporates safety modules and an emergency stop button on the enclosure door. These are used to activate the Safe Torque Off (STO) and turn off the mains power (Customer terminal XT60).

NOTE: Not compatible with **SP07** option.

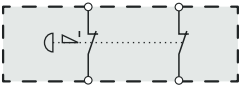
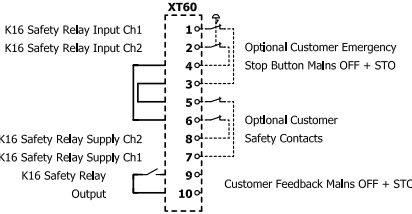
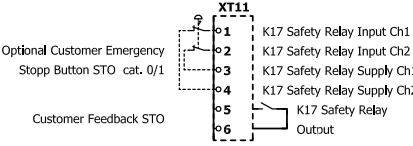
Mains Off button in the enclosure door (1)	Customer terminal XT60 – STO (1)	Customer terminal XT11 – POE
		
<p>NOTE: For all certified architecture refer to the ATV6000 Embedded Safety Function Manual BQT43422 (Refer to the case 2).</p>		

Safe Stop 1 (SS1) SIL2 Stop Category 1 (on terminals) (SP07)

The drive is designed with Safe Torque Off (STO) feature with Safe Stop 1 (SS1) SIL2 Stop Category 1 on terminals (Customer terminal XT11).

The drive incorporates safety modules and an emergency stop button on the enclosure door. These are used to activate the Safe Torque Off (STO) and turn off the mains power (Customer terminal XT60).

NOTE: Not compatible with **SP06** option.

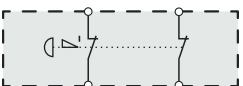
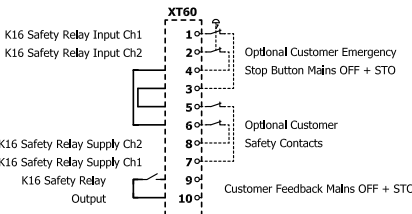
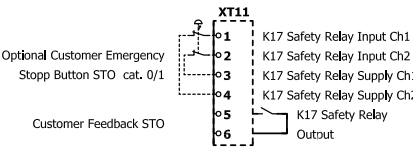
Mains Off button in the enclosure door (1)	Customer terminal XT60 (1)	Customer terminal XT11 (1)
		
<p>NOTE: For all certified architecture refer to the ATV6000 Embedded Safety Function Manual BQT43422 (Refer to the case 3).</p>		

Environment and General Technical Data

Input Short-circuit Current Rating 31.5 kA/1s (E04)

Input section is reinforced to withstand high short circuit current.

Seismic (E07)

ATV6000 has been adapted with a reinforced cabinet design to handle levels equal or below UBC4 at ground level. Validated by simulation. Contact Schneider Electric for equivalence with local code/regulation.

High altitude >1000 m (E08)

For higher altitudes >1000 m, up to 2000 m is possible with derating. Above 2000 m contact your local Schneider Electric representative.

Drive Efficiency = 96.5 % >96 % (E10)

Increase the ATV6000 efficiency from 96 % to 96.5 % by increasing the transformer efficiency from 98 % to 98.5 %.

Maximum Ambient Temperature > 40 °C (E11)

For higher indoor maximum ambient temperature >40 °C, up to 50 °C is possible with derating.

Cabinet and Transformer

Transformer Winding Selection Copper (A67)

Copper Winding for the internal power transformer.

Reactor cabinet for Synchronous Bypass (BCS10)

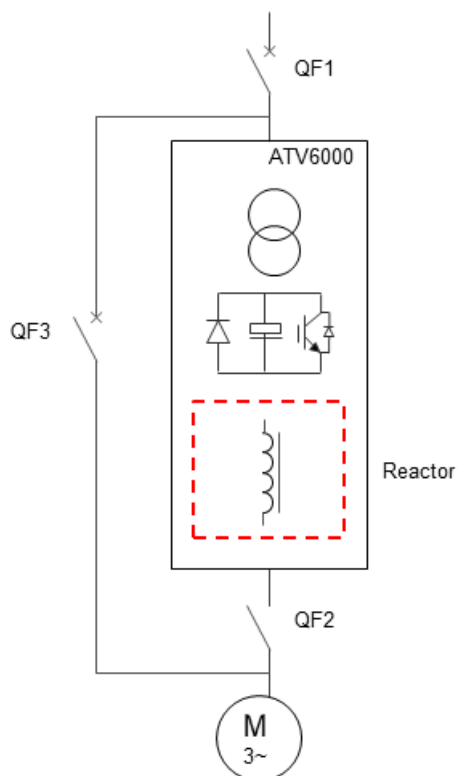

An output reactor is needed for the decoupling of VSD output during the synchronous bypass process. Synchronous bypass is done automatically with one or multiple motors. For switchgear selection and process definition contact your local Schneider Electric representative.

Inrush Current Limit Cabinet (IL01)

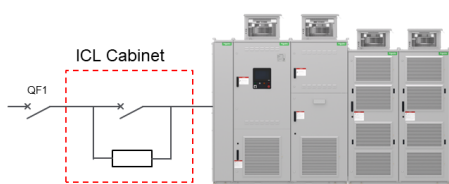

For a weak network is possible to limit the Inrush current up to 1.6 nominal input current caused by the internal power transformer. Typical values for ATV6000 are $\hat{i}_{\text{inrush}} = [8 \text{ to } 14] \times \sqrt{2} \times \text{input_RMS}$ with a time constant limited to 80 to 120 ms.

Harsh Environment

Humidity (E01)

The drive is designed to run in an environment with a relative humidity of up to 95 % (non-condensing).

Cabinet Space Heater (A06)



ATV6000 can be equipped with a cabinet space heater inside the transformer and power cell cabinets to help prevent condensation effect within the cabinets.

The default control logic is management by VSD running signal, the space heater in operation when VSD stop, the space heater out of service when VSD running.

It can be controlled also by following methods:

- Controlled by temperature
- Controlled by humidity and temperature

Cooling Fan Redundant (Transformer Cabinet + Power Cell Cabinet) (E03)



The cooling fans are the only mechanical parts of the drive and therefore subject to wear and tear. The breakdown of a fan could result in overheat and consequently switch off the drive. To prevent this ATV6000 can offer redundant cooling fans option. By a N+1 fans design adapted for transformer and power cell cabinets, each fan is equipped with a shutter (with/without feedback ⁽¹⁾). In case of one inoperative fan, the shutter is closed to avoid short-cut of air flow, meanwhile the redundant fan is switched in by the drive controller.

Benefits:

- Redundant fans prevent production down times or interruptions.
- A warning message is provided to inform about if a fan is not operative.
- Replacement of the faulty cooling fan can be postponed until the next scheduled shutdown.

1) The feedback helps to identify inoperative shutter that could lead to cabinet over temperature, dust penetration, air flow inefficiency.

Optimized Fan Redundancy (E06)



The top fan's size is adapted for transformer and power cell cabinets, and fans are equipped with an electric actuator and shutter, keeping standard dimensions (which is reduced compared to N+1 fan (E03)).

In case one defective fan, the electric actuator will control its shutter to close to avoid short-cut of airflow, meanwhile, the others keep running to provide sufficient airflow. This prevents production downtimes or interruptions, and replacement of the defective cooling fan can be postponed until the next scheduled shutdown.

Contact your local Schneider Electric representative for details.

Air Duct (A01)



Cooling with air duct channel optimizes the design of the air conditioning system. Clean air has to be provided to the drive air inlets.

The air duct is prepared to have an exhaust opening at the rear site.

Protection Level: IP31/P41/IP42 (SP02, SP03, SP04)

The enclosure design exists in three optimized variations, according to particular requirements or preferences. Each solution contains a clearly specified and tested cooling system which provides high reliability. The standard design of the ATV6000 enclosure unit complies with protection degree IP31. If a higher protection degree is desired or required, there are two alternative solutions available, IP41 and IP42.

The degree of protection provided by the enclosure of the electrical equipment aims to:

- Protect person against access to hazardous parts inside the enclosure;
- Protect equipment inside the enclosure against ingress of solid foreign objects;
- Protect equipment inside the enclosure against harmful effects due to the ingress of water.

Guarding Options

QF1 MVCB Interlock Compatibility Box (A02)

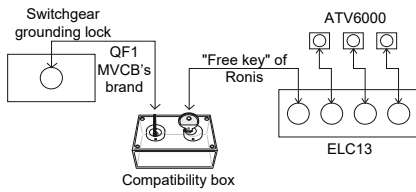

QF1 MVCB interlock ⁽¹⁾ utilizes keys for sequential control of equipment and machinery to avoid that unauthorized person opens the cabinet.

(1) The customer is required to provide the lock cylinder of QF1 MVCB's to Schneider Electric.

Grounding Cable for Maintenance (A07)

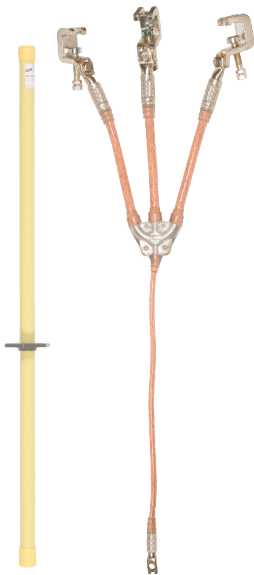

ATV6000 can be equipped with a grounding cable when maintenance for personal and equipment protection.

The grounding cable +stick is a 3 pole grounding and short circuiting device in accordance with IEC61230.

The grounding cable:

- Provides personal and equipment protection during maintenance
- Discharges the residual voltage of power supply operation system.

Short-circuit rating of fixed ball points:

	Maximum permissible I _k for...				
	0.5 s	1 s	2 s	5 s	10 s
VSD Output	33.5 kA	23.7 kA	16.7 kA	10.6 kA	7.5 kA
VSD Input	19.5 kA	13.8 kA	9.8 kA	6.2 kA	4.4 kA

Power cell bypass (PC01)

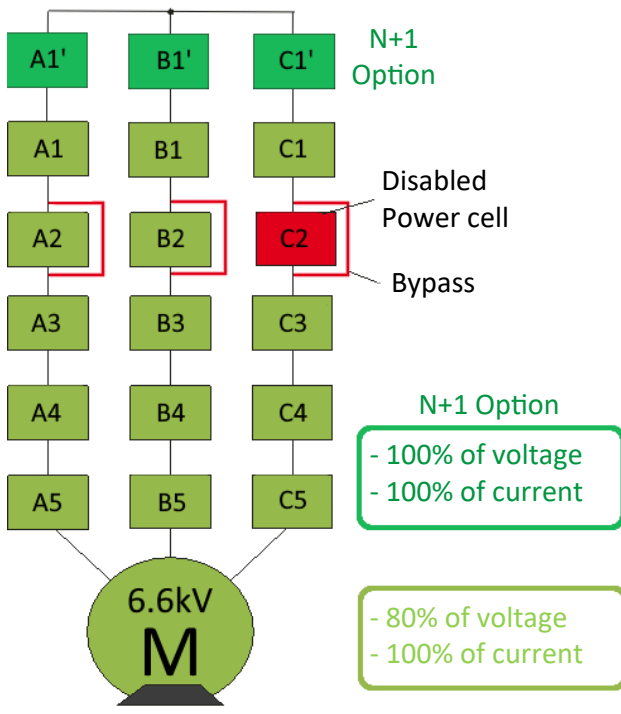

Bypass principle

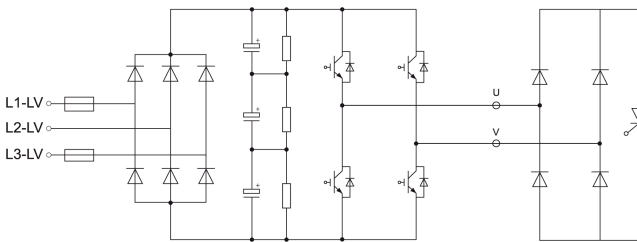

Power cell bypass circuit schematic

It is advisable to use an integrated power cell bypass option for crucial processes, in which case a reduction in capacity is preferable to a complete shutdown.

When a power cell triggers an error, it will automatically bypass the same position power cell in each phase from the main circuit, and the VSD system will maintain running by keeping voltage/speed up to 90% and 100% of current capacity (depending on mains voltage). Errors covered are inoperative IGBT, overheating of power cell and over voltage.

It helps to prevent production downtime or unplanned interruption. Replacement of the inoperative power cell shall be arranged at the next scheduled maintenance.

It is a contactless system which is fully integrated into the power cell, and this makes the power cell entirely modular even with a bypass function.

Power cell Bypass function is available up to 490A output current.

Benefits

- The contactless automatic power cell bypass provides operation by avoiding contact damage due to environmental influence like dust or humidity.
- Increases process availability as the drive will keep on running with negligible load capacity reduction. In most of cases, the optimum load control performance of the pump, fan, or compressor are not affected, as their typical process operation range does not exceed 30 Hz and 45 Hz to generate energy savings.
- Provides crucial process availability until the next scheduled maintenance.

Inverter Redundancy (N+1) (PC02)

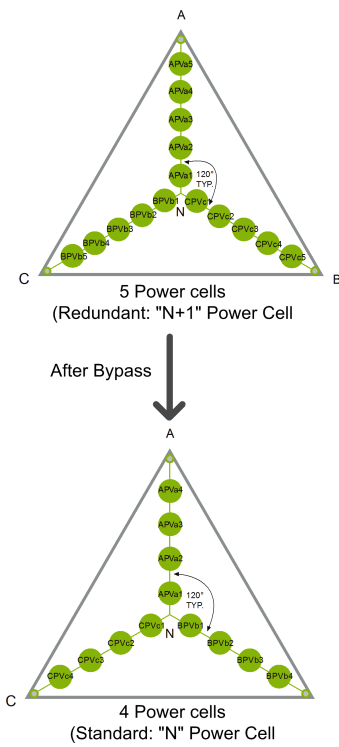

ATV6000 medium voltage drive can be equipped using the inverter redundancy configuration (N+1). With this configuration, the ATV6000 can offer more availability to the process/application with 100% load capability, enabling the pump/fan/conveyor/compressor to operate at full capacity without derating. Both the inverter and transformer section are designed in order to sustain operation at 100% load during power cell bypass.

Inverter redundancy (N+1) is available up to 490 A.

Benefits

- The inverter redundancy design helps to increase the reliability of the whole system in order to increase the availability of service.
- Motor friendly: One power cell in each phase bypassed automatically to keep a neutral point balanced, resulting in less bearing current for significantly low motor stress.
- Rated output: Using redundant inverter configuration, the drive remains able to provide full output voltage and current without any derating of speed or torque.

Inverter Redundancy (N+2) (PC03)

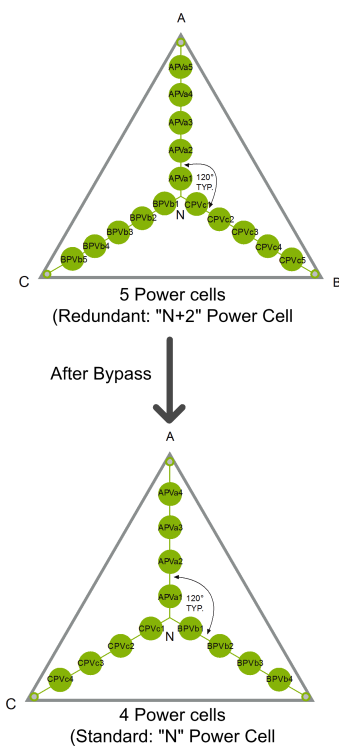

ATV6000 medium voltage drive can be equipped using the inverter redundancy configuration (N+2). With this configuration, the ATV6000 can offer more availability to the process/application with 100% load capability, enabling the pump/fan/conveyor/compressor to operate at full capacity without derating. Both the inverter and transformer section are designed in order to sustain operation at 100% load during power cell bypass.

Inverter redundancy (N+2) is available up to 490 A.

Benefits

- The inverter redundancy design helps to increase the reliability of the whole system in order to increase the availability of service.
- Motor friendly: One power cell in each phase bypassed automatically to keep a neutral point balanced, resulting in less bearing current for significantly low motor stress.
- Rated output: Using redundant inverter configuration, the drive remains able to provide full output voltage and current without any derating of speed or torque.

Arc Flash Detection (E02)



ATV6000 can be equipped with an arc flash detection system (VAMP series). The unit detects an arc flash in an installation and trips the feeding breaker to avoid larger loss of current. Arc flash detection is available in the transformer cabinet and PoC cabinet.

An arc flash detection system runs much faster than conventional relays and thus damage caused by an arc short circuit can be kept to a minimum level.

Benefits

- **Reduces Loss of Production:** The shorter the operating time of the arc flash detection unit, the smaller the damage caused by the arc flash will be, and the shorter the possible outage of the power supply.
- **Prolonged drive Life Cycle:** An unit increases the service life expectancy of Drive installations, investment decisions in new Drive installations can be postponed, and money can be saved.
- **Low Investment Costs and Fast Installation:** A comprehensive arc flash protection is characterized by low investment costs and a fast installation and commissioning time. One successful operation of the arc flash detection units provides immediate investment pay off.
- **Robust Operation:** Function is based on appearance of light or alternatively on the appearance of light and current from external equipment.
- **Vast Experience:** Schneider Electric is the pioneer in the field of arc flash detection with more than 10.000 VAMP arc flash detection systems and units.

Customization

Specific Cabling Color (A50)

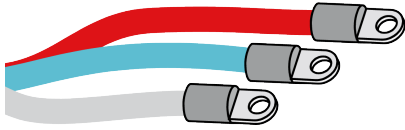

Customized power and control color cables for identification.

Specific Cabinet Color RAL (CC01)

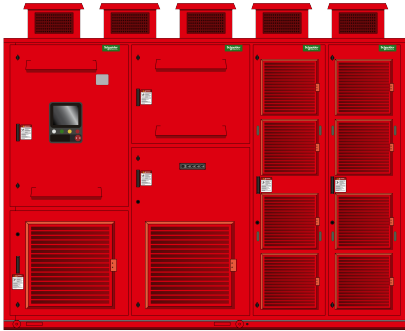

Customized cabinet color according to a RAL, on request.

Schneider Electric
35 rue Joseph Monier
92500 Rueil Malmaison
France

+ 33 (0) 1 41 29 70 00

www.se.com

As standards, specifications, and design change from time to time,
please ask for confirmation of the information given in this publication.

© 2024 Schneider Electric. All rights reserved.

QGH83255.05