

Altivar Process ATV600

Application Note

Multi-Drives Booster Control Optimized

01/2017



The information provided in this documentation contains general descriptions and/or technical characteristics of the performance of the products contained herein. This documentation is not intended as a substitute for and is not to be used for determining suitability or reliability of these products for specific user applications. It is the duty of any such user or integrator to perform the appropriate and complete risk analysis, evaluation and testing of the products with respect to the relevant specific application or use thereof. Neither Schneider Electric nor any of its affiliates or subsidiaries shall be responsible or liable for misuse of the information contained herein. If you have any suggestions for improvements or amendments or have found errors in this publication, please notify us.

No part of this document may be reproduced in any form or by any means, electronic or mechanical, including photocopying, without express written permission of Schneider Electric.

All pertinent state, regional, and local safety regulations must be observed when installing and using this product. For reasons of safety and to help ensure compliance with documented system data, only the manufacturer must perform repairs to components.

When devices are used for applications with technical safety requirements, the relevant instructions must be followed. Failure to use Schneider Electric software or approved software with our hardware products may result in injury, harm, or improper operating results.

Failure to observe this information can result in injury or equipment damage.

© 2017 Schneider Electric. All rights reserved.

Table of Contents



Safety Information	4
About the Book	8
Part I Overview.....	11
Introduction.....	12
Booster Control.....	13
Multi-Pump System Architectures	14
Booster Control Overview.....	15
Booster Control Energy Optimized.....	18
Part II Application Description.....	19
Application Description	20
Wiring.....	22
Part III Prerequisites.....	23
Application Selection	24
Motor Configuration	25
High and Low Speed Configuration	27
System Units Customization.....	28
Command and Reference Value.....	29
Ethernet Settings	30
Sensor Assignment	32
Pump Characteristics.....	35
Head Correction	37
Part IV MultiPump Configuration	39
Pump System Architectures.....	40
MultiDrive Link Configuration.....	41
Part V Booster Control Configuration	43
Booster Control Activation	44
Type of Control Configuration	45
Stage / Destage Condition	46
PID Controller.....	47
Start the Application	49
Part VI Additional Parameters.....	52
MultiDrive Link – Errors & Warning Handling	53
System Architecture – Pumps Configuration.....	55
System Architecture – Pump Cycling Parameters.....	56
Part VII Parameters Table	57
Parameters Table.....	58

Safety Information



Important Information

NOTICE

Read these instructions carefully, and look at the equipment to become familiar with the device before trying to install, operate, or maintain it. The following special messages may appear throughout this documentation or on the equipment to inform of potential hazards or to call attention to information that clarifies or simplifies a procedure.



The addition of this symbol to a Danger safety label indicates that an electrical hazard exists, which will result in personal injury if the instructions are not followed.



This is the safety alert symbol. It is used to alert you to potential personal injury hazards. Obey all safety messages that follow this symbol to avoid possible injury or death.

DANGER

DANGER indicates an imminently hazardous situation which, if not avoided, **results in** death or serious injury.

WARNING

WARNING indicates a potentially hazardous situation which, if not avoided, **can result in** death or serious injury.

CAUTION

CAUTION indicates a potentially hazardous situation which, if not avoided, **can result in** minor or moderate injury.

NOTICE

NOTICE is used to address practices not related to physical injury.

PLEASE NOTE

Electrical equipment should be installed, operated, serviced, and maintained only by qualified personnel. No responsibility is assumed by Schneider Electric for any consequences arising out of the use of this material.

A qualified person is one who has skills and knowledge related to the construction and operation of electrical equipment and its installation, and has received safety training to recognize and avoid the hazards involved.

Intended Use

This product is a drive for three-phase synchronous and asynchronous motors and intended for industrial use according to this manual. The product may only be used in compliance with all applicable safety regulations and directives, the specified requirements and the technical data. Prior to using the product, you must perform a risk assessment in view of the planned application. Based on the results, the appropriate safety measures must be implemented. Since the product is used as a component in an entire system, you must ensure the safety of persons by means of the design of this entire system (for example, machine design). Any use other than the use explicitly permitted is prohibited and can result in hazards. Electrical equipment should be installed, operated, serviced, and maintained only by qualified personnel.

Product Related Information

Read and understand these instructions before performing any procedure with this drive.

DANGER

HAZARD OF ELECTRIC SHOCK, EXPLOSION OR ARC FLASH

- Only appropriately trained persons who are familiar with and understand the contents of this manual and all other pertinent product documentation and who have received safety training to recognize and avoid hazards involved are authorized to work on and with this drive system. Installation, adjustment, repair and maintenance must be performed by qualified personnel.
- The system integrator is responsible for compliance with all local and national electrical code requirements as well as all other applicable regulations with respect to grounding of all equipment.
- Many components of the product, including the printed circuit boards, operate with mains voltage. Do not touch.
- Only use properly rated, electrically insulated tools and measuring equipment.
- Do not touch unshielded components or terminals with voltage present.
- Motors can generate voltage when the shaft is rotated. Prior to performing any type of work on the drive system, block the motor shaft to prevent rotation.
- AC voltage can couple voltage to unused conductors in the motor cable. Insulate both ends of unused conductors of the motor cable.
- Do not short across the DC bus terminals or the DC bus capacitors or the braking resistor terminals.
- Before performing work on the drive system:
 - Disconnect all power, including external control power that may be present.
 - Place a **Do Not Turn On** label on all power switches related to the drive system.
 - Lock all power switches in the open position.
 - Wait 15 minutes to allow the DC bus capacitors to discharge.
 - Follow the instructions given in the chapter "Verifying the Absence of Voltage" in the installation manual of the product.
- Before applying voltage to the drive system:
 - Verify that the work has been completed and that the entire installation cannot cause hazards.
 - If the mains input terminals and the motor output terminals have been grounded and short-circuited, remove the ground and the short circuits on the mains input terminals and the motor output terminals.
 - Verify proper grounding of all equipment.
 - Verify that all protective equipment such as covers, doors, grids is installed and/or closed

Failure to follow these instructions will result in death or serious injury.

Drive systems may perform unexpected movements because of incorrect wiring, incorrect settings, incorrect data or other errors.

WARNING

UNANTICIPATED EQUIPMENT OPERATION

- Carefully install the wiring in accordance with the EMC requirements.
- Do not operate the product with unknown or unsuitable settings or data.
- Perform a comprehensive commissioning test.

Failure to follow these instructions can result in death, serious injury, or equipment damage.

Damaged products or accessories may cause electric shock or unanticipated equipment operation.

DANGER

ELECTRIC SHOCK OR UNANTICIPATED EQUIPMENT OPERATION

Do not use damaged products or accessories.

Failure to follow these instructions will result in death or serious injury.

Contact your local Schneider Electric sales office if you detect any damage whatsoever.

WARNING

LOSS OF CONTROL

- The designer of any control scheme must consider the potential failure modes of control paths and, for critical control functions, provide a means to achieve a safe state during and after a path failure. Examples of critical control functions are emergency stop, overtravel stop, power outage and restart.
- Separate or redundant control paths must be provided for critical control functions.
- System control paths may include communication links. Consideration must be given to the implications of unanticipated transmission delays or failures of the link.
- Observe all accident prevention regulations and local safety guidelines (1).
- Each implementation of the product must be individually and thoroughly tested for proper operation before being placed into service.

Failure to follow these instructions can result in death, serious injury, or equipment damage.

(1) For USA: Additional information, refer to NEMA ICS 1.1 (latest edition), Safety Guidelines for the Application, Installation, and Maintenance of Solid State Control and to NEMA ICS 7.1 (latest edition), Safety Standards for Construction and Guide for Selection, Installation and Operation of Adjustable-Speed Drive Systems.

This equipment has been designed to operate outside of any hazardous location. Only install this equipment in zones known to be free of hazardous atmosphere.

DANGER

POTENTIAL FOR EXPLOSION

Install and use this equipment in non-hazardous locations only.

Failure to follow these instructions will result in death or serious injury.

Machines, controllers, and related equipment are usually integrated into networks. Unauthorized persons and malware may gain access to the machine as well as to other devices on the network/fieldbus of the machine and connected networks via insufficiently secure access to software and networks.

 **WARNING**

UNAUTHORIZED ACCESS TO THE MACHINE VIA SOFTWARE AND NETWORKS

- In your hazard and risk analysis, consider all hazards that result from access to and operation on the network/fieldbus and develop an appropriate cyber security concept.
- Verify that the hardware infrastructure and the software infrastructure into which the machine is integrated as well as all organizational measures and rules covering access to this infrastructure consider the results of the hazard and risk analysis and are implemented according to best practices and standards covering IT security and cyber security (such as: ISO/IEC 27000 series, Common Criteria for Information Technology Security Evaluation, ISO/IEC 15408, IEC 62351, ISA/IEC 62443, NIST Cybersecurity Framework, Information Security Forum - Standard of Good Practice for Information Security).
- Verify the effectiveness of your IT security and cyber security systems using appropriate, proven methods.

Failure to follow these instructions can result in death, serious injury, or equipment damage.

About the Book



At a Glance

Document Scope

The purpose of this document is to show how to configure a Multi-Drives Booster Control Optimized.

The document is structured in six main parts which are:

- Overview: this part gives an approach of Altivar Process ATV600 capabilities inside process industry.
- Application Description: this part provides the application and architecture selected for this application note.
- Prerequisites: this part provides the minimum steps to achieve before starting the Booster Control Optimized commissioning.
- MultiPump Configuration: this part provides the steps to configure the Multi-Drives Architecture and MultiDrive Link feature.
- Booster Control Optimized: this part provides the minimum steps to achieve to configure the Booster Control Optimized application
- Additional Parameters: this part provides details on parameters which allow advanced configuration of the Booster Control Optimized application.

NOTE: Read and understand this document and all related documents (see below) before installing, operating, or maintaining your drive.

Validity Note

This document is valid for the Altivar Process ATV600 drives.

The technical characteristics of the devices described in this document also appear online. To access this information online:

Step	Action
1	Go to Schneider Electric home page www.schneider-electric.com
2	In the Search box type the reference of a product or the name of a product range. <ul style="list-style-type: none">• Do not include blank spaces in the model number/product range.• To get information on grouping similar modules, use asterisks (*).
3	If you entered a reference, go to the Product Datasheets search results and click on the reference that interests you. If you entered the name of a product range, go to the Product Ranges search results and click on the product range that interests you
4	If more than one reference appears in the Products search results, click on the reference that interests you
5	Depending on the size of your screen, you may need to scroll down to see the data sheet.
6	To save or print a data sheet as a .pdf file, click Download XXX product datasheet.

The characteristics that are presented in this manual should be the same as those characteristics that appear online. In line with our policy of constant improvement, we may revise content over time to improve clarity and accuracy. If you see a difference between the manual and online information, use the online information as your reference.

Related Documents

Use your tablet or your PC to quickly access detailed and comprehensive information on all our products on www.schneider-electric.com

The internet site provides the information you need for products and solutions

- The whole catalog for detailed characteristics and selection guides
- The CAD files to help design your installation, available in over 20 different file formats
- All software and firmware to maintain your installation up to date
- A large quantity of White Papers, Environment documents, Application solutions, Specifications... to gain a better understanding of our electrical systems and equipment or automation
- And finally all the User Guides related to your drive, listed below:

Title of Documentation	Reference Number
ATV600 Getting Started	EAV63253 (English), EAV63254 (French), EAV63255 (German), EAV63256 (Spanish), EAV64310 (Italian), EAV64298 (Chinese)
ATV600 Getting Started Annex (SCCR)	EAV64300 (English)
ATV630, ATV650 Installation Manual	EAV64301 (English), EAV64302 (French), EAV64306 (German), EAV64307 (Spanish), EAV63257 (Italian), EAV64317 (Chinese)
ATV630, ATV650 Programming Manual	EAV64318 (English), EAV64320 (French), EAV64321 (German), EAV64322 (Spanish), EAV64323 (Italian), EAV64324 (Chinese)
ATV600 Modbus Serial Link Manual	EAV64325 (English)
ATV600 Ethernet Manual (Embedded)	EAV64327 (English)
ATV600 Ethernet IP - Modbus TCP Manual (VW3A3720, VW3A3721)	EAV64328 (English)
ATV600 PROFIBUS DP manual (VW3A3607)	EAV64329 (English)
ATV600 DeviceNet manual (VW3A3609)	EAV64330 (English)
ATV600 PROFINET manual (VW3A3627)	EAV64331 (English)
ATV600 CANopen manual (VW3A3608, 618, 628)	EAV64333 (English)
ATV600 Communication Parameters	EAV64332 (English)
ATV600 Safety Function manual	EAV64334 (English)
Altivar Process Drive Systems - Installation manual	NHA37119 (English), NHA37121 (French), NHA37118 (German), NHA37122 (Spanish), NHA37123 (Italian), NHA37130 (Chinese), NHA37124 (Dutch), NHA37126 (Polish), NHA37127 (Portuguese), NHA37128 (Russian), NHA37129 (Turkish)
ATV660 Handbook	NHA37111 (English), NHA37110 (German)
ATV680 Handbook	NHA37113 (English), NHA37112 (German)
SoMove : FDT	SoMove_FDT (English, French, German, Spanish, Italian, Chinese)
Altivar Process ATV600 : DTM	ATV6xx DTM Library EN (English), ATV6xx DTM Lang FR (French), ATV6xx DTM Lang DE (German), ATV6xx DTM Lang SP (Spanish), ATV6xx DTM Lang IT (Italian), ATV6xx DTM Lang CN (Chinese)

You can download these technical publications and other technical information from our website at <http://download.schneider-electric.com>

Terminology

The technical terms, terminology, and the corresponding descriptions in this manual normally use the terms or definitions in the relevant standards.

In the area of drive systems this includes, but is not limited to, terms such as **error, error message, failure, fault, fault reset, protection, safe state, safety function, warning, warning message**, and so on.

Among others, these standards include:

- IEC 61800 series: Adjustable speed electrical power drive systems
- IEC 61508 Ed.2 series: Functional safety of electrical/electronic/programmable electronic safety-related
- EN 954-1 Safety of machinery - Safety related parts of control systems
- EN ISO 13849-1 & 2 Safety of machinery - Safety related parts of control systems.
- IEC 61158 series: Industrial communication networks - Fieldbus specifications
- IEC 61784 series: Industrial communication networks - Profiles
- IEC 60204-1: Safety of machinery - Electrical equipment of machines – Part 1: General requirements

In addition, the term **zone of operation** is used in conjunction with the description of specific hazards, and is defined as it is for a **hazard zone** or **danger zone** in the EC Machinery Directive (2006/42/EC) and in ISO 12100-1.

Part I

Overview

What is in This Part?

This part contains the following topics:

Introduction.....	12
Booster Control	13
Multi-Pump System Architectures	14
Booster Control Overview	15
Booster Control Energy Optimized	18

Introduction

About This Application Note

The goal of this Application Note is to provide a commissioning procedure to configure a Multi-Drives Booster Control Optimized application.

This Application Note does not cover all the use cases and cannot be consider as a substitution of the ATV600 Programming Manual.

For more details about the Booster Control Optimized function embedded on Altivar Process ATV600 drives, please refer to the ATV600 Programming Manual (EAV64318).

Booster Control

About Booster Control

Booster Control is used to maintain a constant pressure at the outlet by varying the speed of the pumps. Altivar Process ATV600 drives allow these pumps to have an optimized consumption of the power and at the same time, provide optimized monitoring features.

Booster Control Applications

Booster Control is used in several pumping processes.

Applications example for Water and Waste Water, where Booster Control can be used depending of the Booster Control mode:

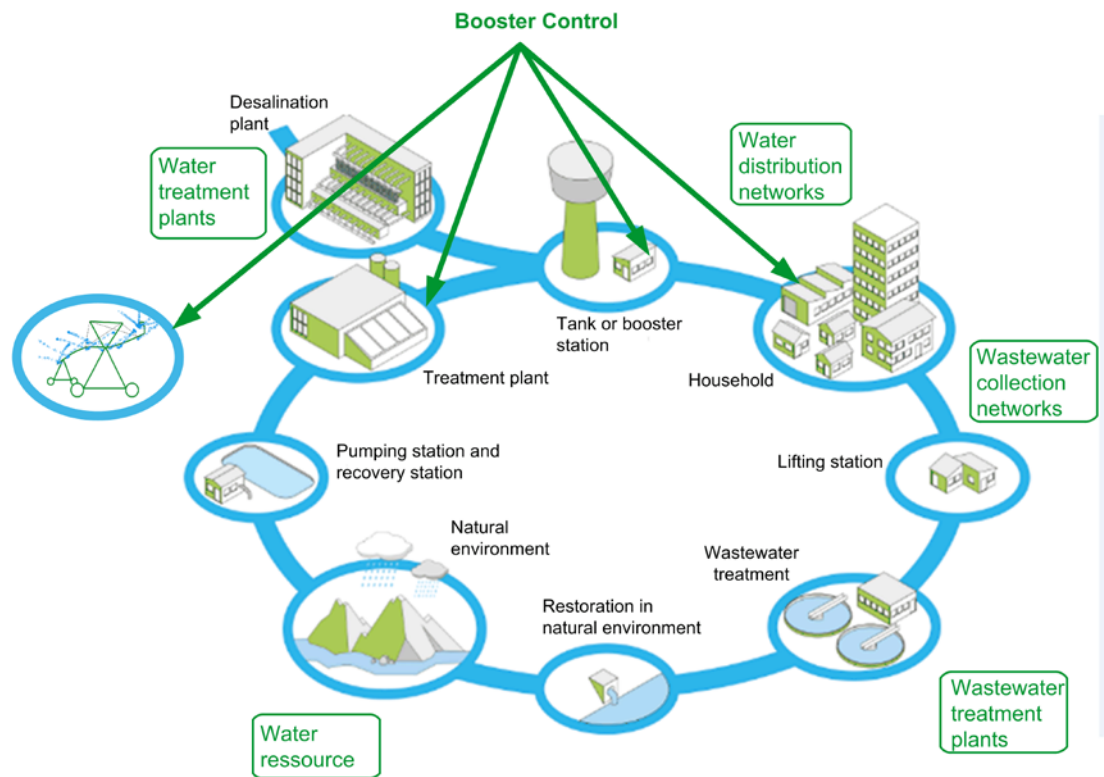

Multi-Pump System Architectures

About Multi-Pump System Architectures

Several Multi-Pump System Architectures exist in process industry. Altivar Process ATV600 drives can be used in several architectures.

Supported Multi-Pump Architectures

The following table shows the Altivar Process ATV600 capabilities for integration into Multi-Pump Architectures:

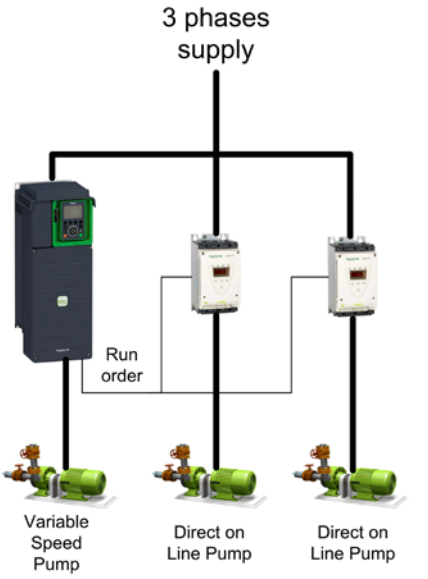
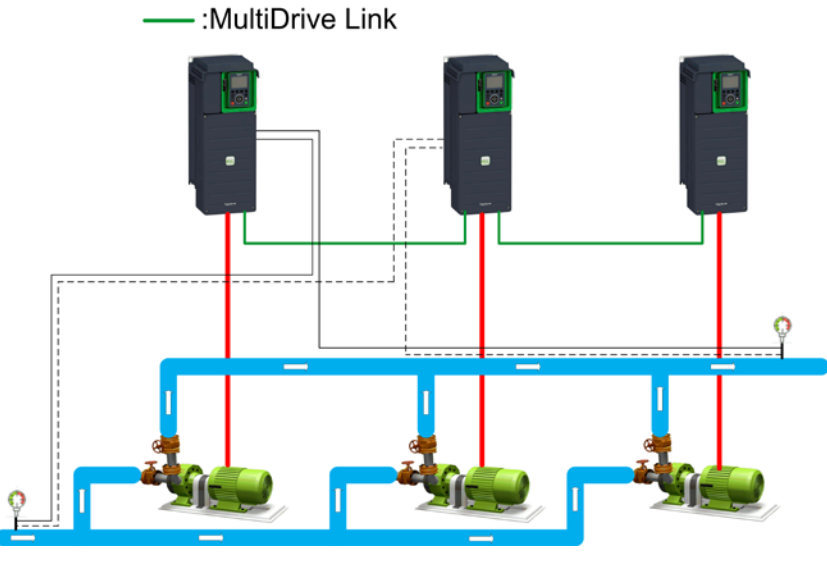
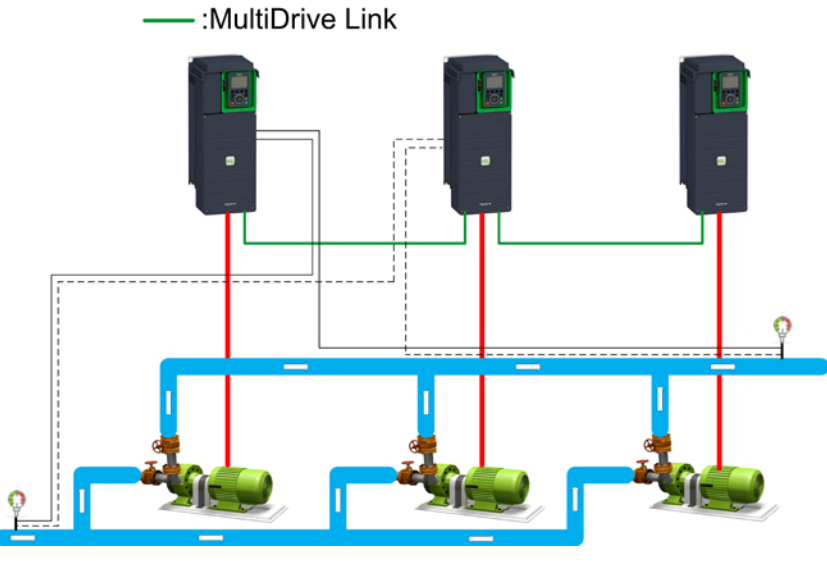
Single Drive	Multiple Drives	Multiple Drives & Service continuity
 <p>3 phases supply</p> <p>Run order</p> <p>Variable Speed Pump</p> <p>Direct on Line Pump</p> <p>Direct on Line Pump</p>	 <p>— :MultiDrive Link</p>	
<p>This architecture can be found on simple installations.</p> <p>It provides basic control of the complete installation with a single drive.</p> <p>The Altivar Process ATV600 drive is able to control up to 5 direct on line (or Starter controlled) pumps in addition to the variable speed one.</p>	<p>This architecture can be found in advanced installations.</p> <p>It provides advanced control of the complete installation including the variable speed drives.</p> <p>The Master drive can control up to 5 Slaves through Multi-Drive Link technology.</p> <p>In Multiple Drives architecture, sensors are wired to the Master (continuous grey line in the schema)</p> <p>NOTE: Altivar Process ATV600 drives must be linked together through a Dual Port Ethernet fieldbus module (VW3A3721) plugged on each Altivar Process ATV600.</p>	<p>This architecture can be found in advanced installations where service continuity is needed.</p> <p>It provides advanced control of the complete installation including the variable speed drives.</p> <p>The drives on the installation can act as Master, Master or Slave, or Slave only through Multi-Drive Link technology.</p> <p>In Multiple Drives & Service Continuity, sensors are wired to the Master and to the Secondary Master (continuous and dotted grey line).</p> <p>NOTE: Altivar Process ATV600 drives must be linked together through a Dual Port Ethernet fieldbus module (VW3A3721) plugged on each Altivar Process ATV600.</p>

Booster Control Overview

Introduction

The aim of the booster control function is to maintain the desired pressure or flow at the outlet of the pumps according to the demand by:

- Managing the velocity of the variable speed pump connected to the drive.
- Staging / destaging the variable speed pumps or auxiliary fixed speed pumps.

Control Type

The type of control allows selecting which kind of process is used for the feedback, setpoint and other related values to control the PID

- Pressure: The system is based on pressure unit. This type of control is used for pressure regulation applications
- Flow: The system is based on flow unit. This type of control is used for flow regulation applications

Speed Control

Distributed Speed Control Mode

This speed control mode is available for **Multiple Drives architecture**.

The pumps will be staged and destaged one by one. The last staged pumps run at variable speed and other pumps run at fixed speed.

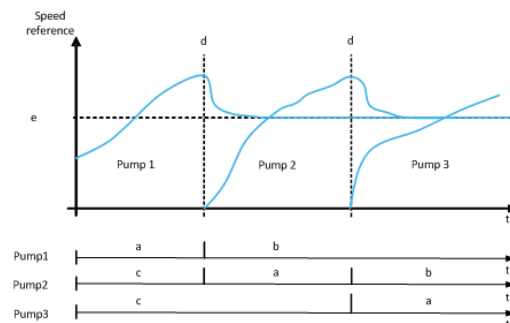

- a) Pump runs at variable speed
- b) Pump runs at fixed speed
- c) Pump stopped
- d) Pump staging
- e) Fixed reference frequency in distributed mode

Advanced Speed Control Mode

This speed control mode is available for **Multiple Drives architecture**.

The pumps are staged and destaged one by one. The pumps run at the same speed.

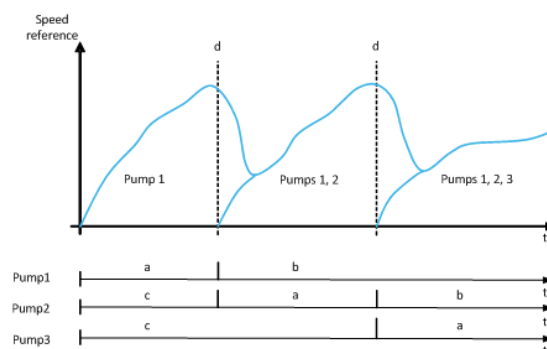

- a) Pump runs at variable speed
- b) Pump speed follows the last staged pump speed
- c) Pump stopped
- d) Pump staging

Traditional Control Mode

This speed control mode is available for **Single Drive architecture**.

There is only one variable speed pump. The variable speed is started first. Other pumps are staged / destaged one by one running at fixed speed, according to the need

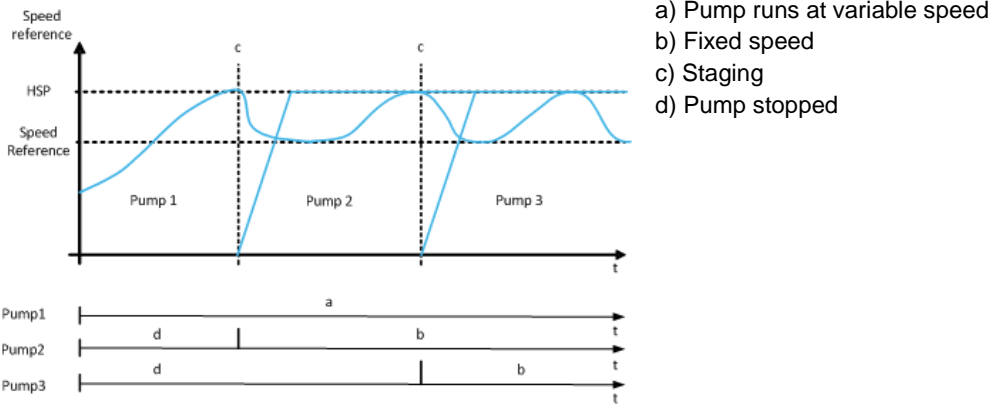

Stage / De-Stage Condition

It is possible to select the condition on which the pump is staged or de-staged:

- **Speed:** staging/destaging occurs according to conditions on the drive output frequency (Lead pump velocity).
- **Feedback:** staging/destaging occurs according to conditions on the outlet pressure feedback.
- **Speed + Flow:** staging occurs according to conditions on the drive output frequency (pump velocity), destaging occurs according to flow conditions.
- **Feedback + Flow:** staging occurs according to conditions on the outlet pressure feedback, destaging occurs according to flow conditions.
- **Energy Optimized:** staging/destaging occurs automatically to optimize the energy consumption of the system.

NOTE: In Advanced Speed Control Mode, destage on speed or feedback is not possible because the pumps are running at the same speed.

Stage / Destage Condition	Control Type (PID Feedback)	Multiple Drives		Single Drive
		Distributed Control Mode	Advanced Control Mode	Traditional Control Mode
Stage and Destage on Speed	Pressure or Flow	✓		✓
Stage and Destage on PID Feedback	Pressure or Flow	✓		✓
Stage on Speed + Destage on Flow. ⁽¹⁾	Pressure		✓	
Stage on PID Feedback + Destage on Flow. ⁽¹⁾	Pressure		✓	
Stage / Destage according to best efficiency. ⁽²⁾	Pressure		✓	
NOTE :				
⁽¹⁾ : Based on installation flow or estimation				
⁽²⁾ : Need pump curves				

Stage / De-stage Method

Once the condition of stage / de-stage is reached, different methods can be applied to manage the transition of stage / de-stage:

- **Speed:** during stage/de-stage, PID controller is by-passed and a fixed reference frequency is applied.
- **Feedback:** outlet pressure remains regulated by the PID controller during stage/destage.
- **Advanced:** outlet pressure remains regulated by the PID controller during stage/destage and disturbances due to stage/de-stage are taken into account by the PID controller to reduce them.

Stage / De-stage Method	Control Type (PID Feedback)	Multiple Drives		Single Drive
		Distributed Control Mode	Advanced Control Mode	Traditional Control Mode
Speed	Pressure or Flow			✓
Feedback	Pressure or Flow	✓	✓	✓
Advanced (Feedback + feed forward)	Pressure			✓

Booster Control Energy Optimized

Energy Optimized

The Booster Control strategy used in this Application Note is: Energy Optimized Booster Control. In this strategy, the optimal number of pumps to start is defined to maintain power consumption as low as possible (maximum efficiency).

The staging/destaging will occur automatically to optimize energy consumption of the system.

- The pump curve characteristics have to be configured in PHQ mode.
- The Installation flow sensor or estimated system flow needs to be configured.
- A Booster staging / de-staging hysteresis can be configured to avoid many stages / destages of pumps.
- Head vs Pressure can be configured to improve performances in case of high friction losses (valve, pipes,...) between inlet and outlet pressure sensors.

Advantages

- Energy saving
- Easy to configure
- Work at the best working area of the pumps (increase pump lifetime)

Part II

Application Description

What is in This Part?

This part contains the following topics:

Application Description.....	20
Wiring.....	22

Application Description

Introduction

This Application Note describes Booster Control Optimized application with 3 Altivar Process ATV600 variable speed drives.

The following parts of this Application Note describe the commissioning procedure for this architecture.

Application Description

The architecture used as example for this application note is the following:

- 3 Altivar Process ATV600 variable speed drives connected through MultiDrive Link.
- 3 Ethernet/IP / ModbusTCP fieldbus modules VW3A3721
- 3 identical pumps and their associated electrical motors.
- 1 Pressure sensor at the system suction (inlet pressure sensor)
- 1 Pressure sensor at the system discharge (outlet pressure sensor).
- 1 Flow sensor to measure the installation flow.
- Pressure setpoint 6 bar.
- Maximum installation flow : 60 m³/h

The following figure shows the water architecture used in this application note:

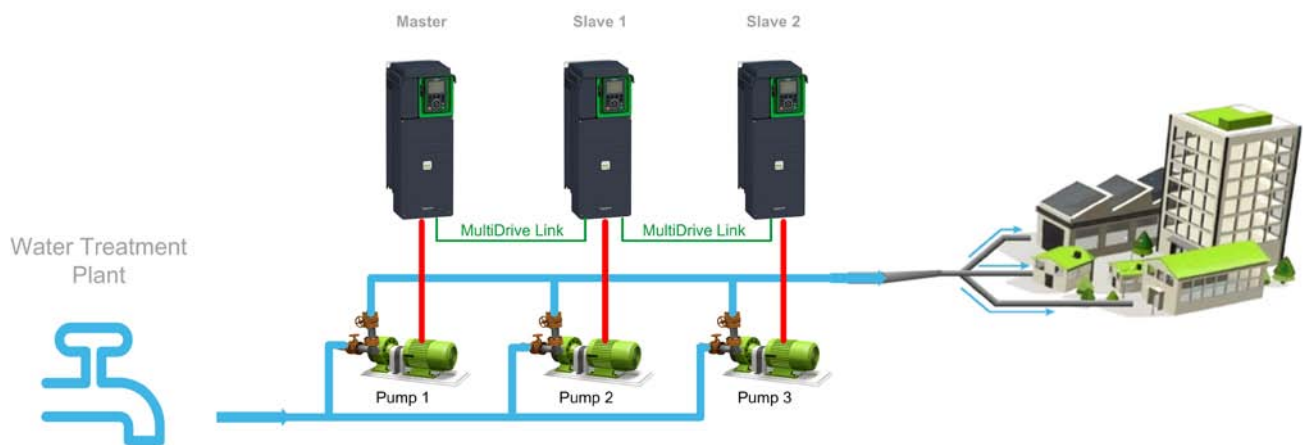

Motor Characteristics

The following table gives the motor characteristics used in this application.

You can write the value for your application on the **Customer Value** column

Parameter	Application Note Value	Customer Value
Motor standard	50 Hz	
Nominal power	5.5 kW	
Nominal voltage	400 Vac	
Nominal current	11.20 A	
Nominal frequency	50.0 Hz	
Nominal speed	2,930 rpm	

Pump Characteristics

The following table gives the pump characteristics used in this application.

You can write the value for your application on the **Customer Value** column

Point	Application Note Value			Customer Value		
	Flow (m ³ /h)	Head (bar)	Power (kW)	Flow	Head	Power
1	15.4	4.60	3.79			
2	21.0	4.40	4.42			
3	37.8	3.38	5.82			
4	41.5	3.00	5.97			
5	45.5	2.52	6.12			
BEP	32.2	3.82	5.47			

The following pump curve shows the selected points for this Application Note:

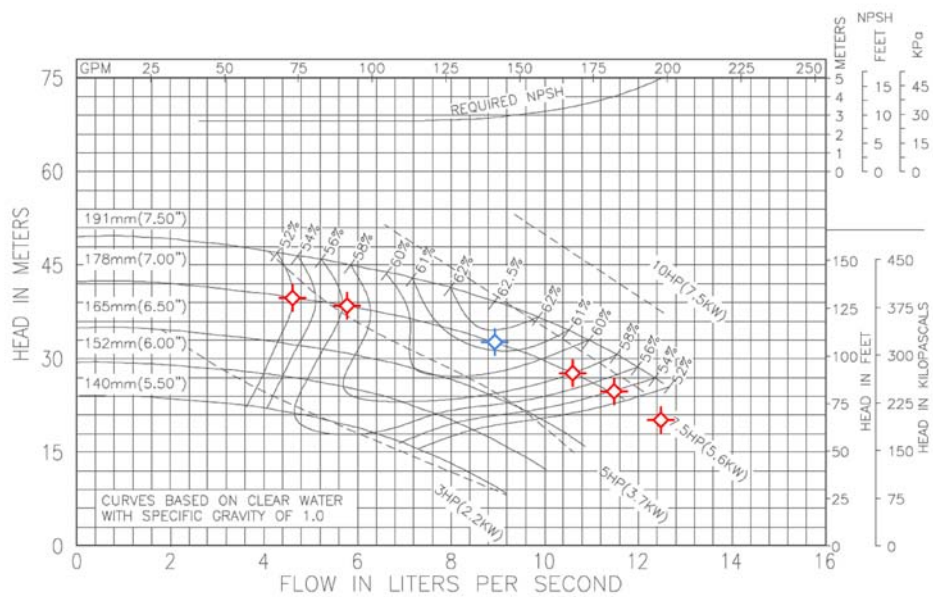

Wiring

What is in This Chapter?

The following part of this Application Note describes the wiring procedure for this architecture.

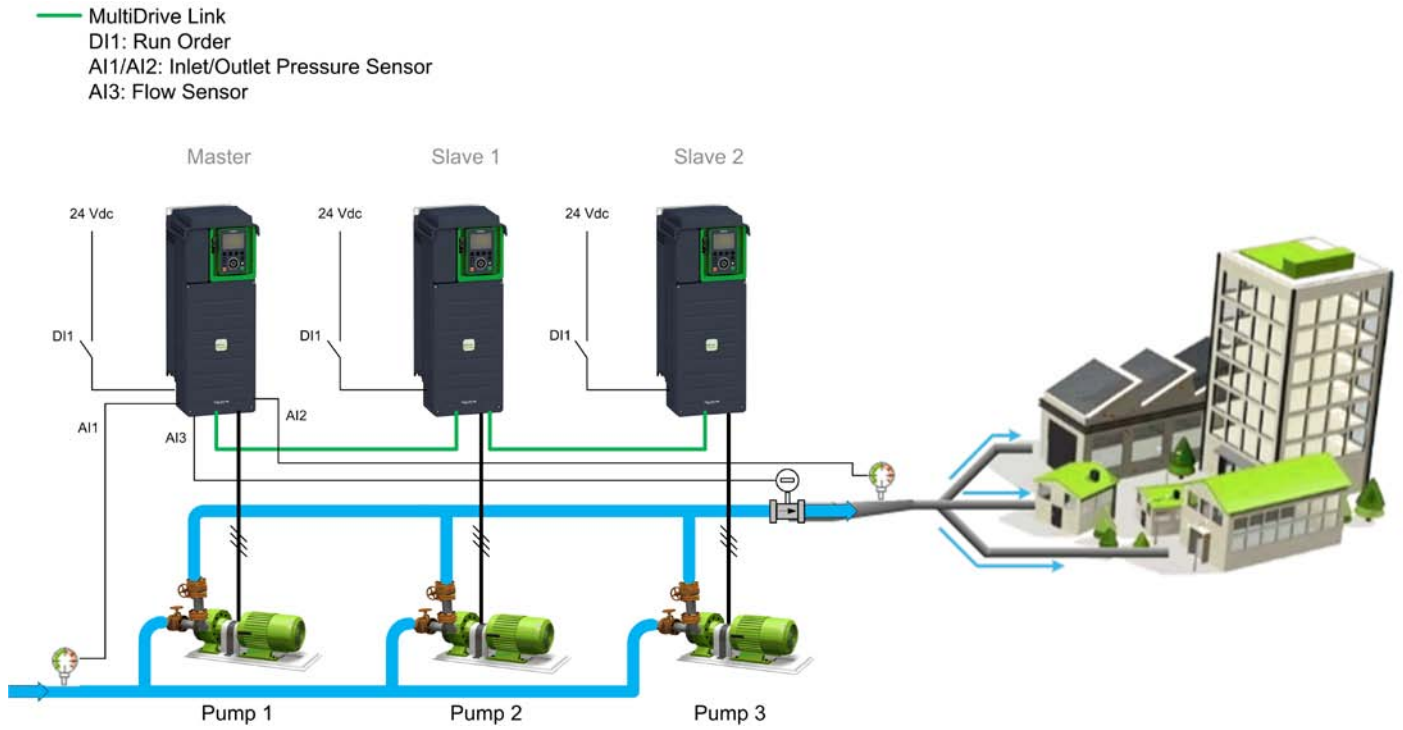

The following table gives the range value according to the sensor type:

You can write the value for your application on the **Customer Value** column

Analog Input	Sensor	Range Value			
		Application Note		Customer Value	
		Sensor	Process	Sensor	Process
AI1	Inlet Pressure	4-20 mA 0 – 4 bar (abs)	-1 – 3 bar (rel)		
AI2	Outlet Pressure	4-20 mA 0 – 10 bar (rel)	0 – 10 bar (rel)		
AI3	Installation System Flow	4-20 mA 0 – 80 m ³ /h	0 – 80 m ³ /h		

NOTE : Pressure analog inputs minimum and maximum settings have to be in the same referential frame
 Absolute = Relative – atmospheric pressure (usually value 1 bar)

Part III

Prerequisites

Introduction

This part describes the initial steps to perform before configuring the Booster Control Optimized application.

The values of parameters given in this part correspond to the architecture selected for this Application Note.

NOTE: Settings may vary according to the architecture needs.

NOTE: Before starting the drive configuration, ensure that the drive is reset to factory settings.

What is in This Part?

This part contains the following topics:

Application Selection	24
Motor Configuration	25
High and Low Speed Configuration.....	27
System Units Customization.....	28
Command and Reference Value	29
Ethernet Settings	30
Sensor Assignment	32
Pump Characteristics	35
Head Correction	37

Application Selection

Overview

The macro-configuration menu allows you to select the appropriate application functions.

This selection gives access to the dedicated functions and associated parameters.

Step by Step Configuration

The following table gives the step by step configuration of the Application Selection parameter:

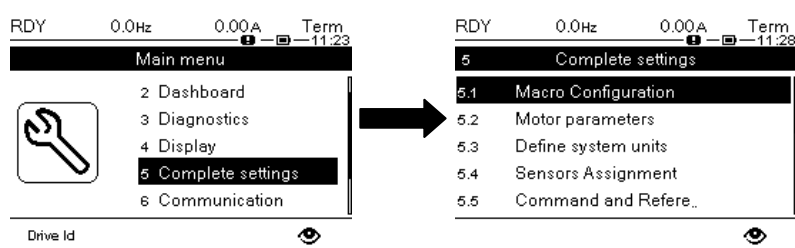
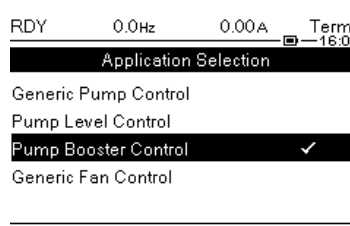
Step	Action
1	<p>Go to [Complete Settings] <i>⏏ 5 ⏏</i> → [Macro Configuration] <i>⏏ 5 ⏏</i> menu</p> 
2	<p>Set [Application Selection] <i>⏏ 5 ⏏</i> to [Pump Booster Control] <i>⏏ 5 ⏏</i></p> 

Motor Configuration

Overview

The motor parameters have to be set to allow optimized motor control performances.

The parameters have to be entered according to the motor nameplate.

Step by Step Configuration

The following table gives the step by step configuration of the motor parameters:

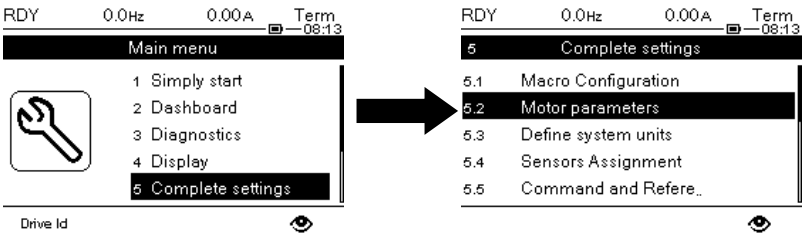
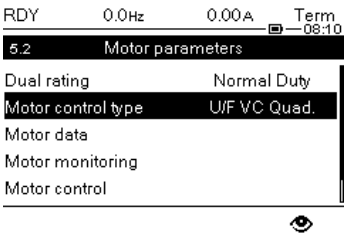
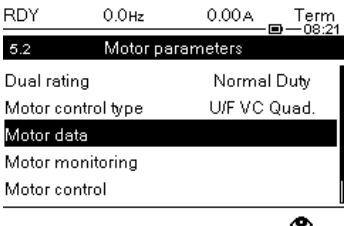
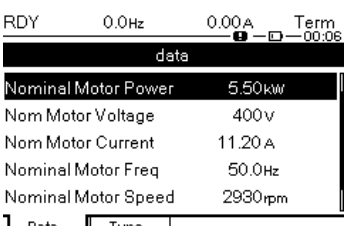
Step	Action
1	<p>Go to [Complete Settings] <i>C S E</i> - menu, [Motor parameters] <i>MPA</i> - submenu.</p>  <p>The screenshot shows the main menu with options: 1 Simply start, 2 Dashboard, 3 Diagnostics, 4 Display, and 5 Complete settings. An arrow points from option 5 to a submenu with options: 5.1 Macro Configuration, 5.2 Motor parameters, 5.3 Define system units, 5.4 Sensors Assignment, and 5.5 Command and Refere..</p>
2	<p>Set [Motor Control Type] <i>CEE</i> to [U/F VC Quad.] <i>UFQ</i>.</p>  <p>The screenshot shows the '5.2 Motor parameters' submenu with options: Dual rating (Normal Duty), Motor control type (U/F VC Quad.), Motor data, Motor monitoring, and Motor control.</p>
3	<p>Go to [Motor data] <i>PEd</i> - submenu.</p>  <p>The screenshot shows the '5.2 Motor parameters' submenu with options: Dual rating (Normal Duty), Motor control type (U/F VC Quad.), Motor data, Motor monitoring, and Motor control.</p>
4	<p>On [Data] tab, set the motor parameters according to the motor nameplate:</p> <ul style="list-style-type: none"> • [Motor Standard] <i>BFr</i> : [50 Hz IEC] 50 • [Nominal Motor Power] <i>nPr</i> : 5.50 kW • [Nom Motor Voltage] <i>unS</i> : 400 Vac • [Nom Motor Current] <i>nCr</i> : 11.20 A • [Nominal Motor Freq] <i>FrS</i> : 50.0 Hz • [Nominal Motor Speed] <i>nSP</i> : 2,930 rpm  <p>The screenshot shows the 'data' tab with parameters: Nominal Motor Power 5.50kw, Nom Motor Voltage 400v, Nom Motor Current 11.20A, Nominal Motor Freq 50.0Hz, and Nominal Motor Speed 2930rpm. There are 'Data' and 'Tune' buttons at the bottom.</p>

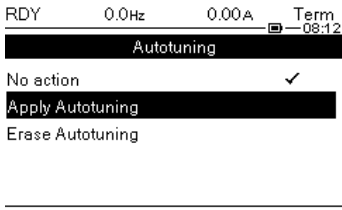
Step	Action
5	<p data-bbox="467 232 1219 262">On [Tune] tab, set [Autotuning] <i>Autotuning</i> to [Apply Autotuning] <i>Apply</i>.</p>  <p data-bbox="467 293 810 322">RDY 0.0Hz 0.00A Term 08:12</p> <p data-bbox="467 322 810 351">Autotuning</p> <p data-bbox="467 351 810 380">No action ✓</p> <p data-bbox="467 380 810 409">Apply Autotuning</p> <p data-bbox="467 409 810 439">Erase Autotuning</p> <hr data-bbox="467 495 810 501"/>
6	<p data-bbox="467 568 863 598">Verify the good direction of the motor</p> <p data-bbox="467 598 975 627">If you need to modify the direction of the motor:</p> <ul data-bbox="467 627 1404 728" style="list-style-type: none"> <li data-bbox="467 627 715 656">• Modify the wiring, or <li data-bbox="467 656 1404 728">• Go to [Complete settings] <i>Complete</i> → [Motor parameters] <i>Motor</i> → [Motor control] <i>Motor</i> → [Output Ph Rotation] <i>Output</i> to [ACB] <i>ACB</i>
7	<p data-bbox="467 741 1110 770">Repeat this procedure for each drive used in the application.</p>

High and Low Speed Configuration

Overview

It is advisable to configure a low speed of the pump to avoid no flow at the outlet of the pump.

Step by Step Configuration

The following table gives the step by step configuration of the high and low speed parameters:

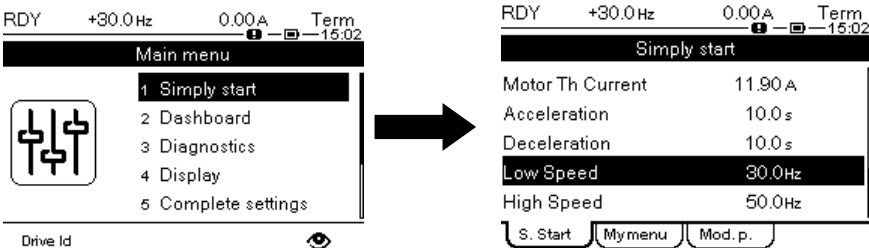
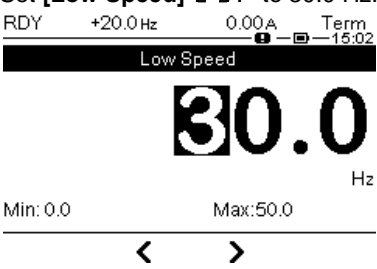
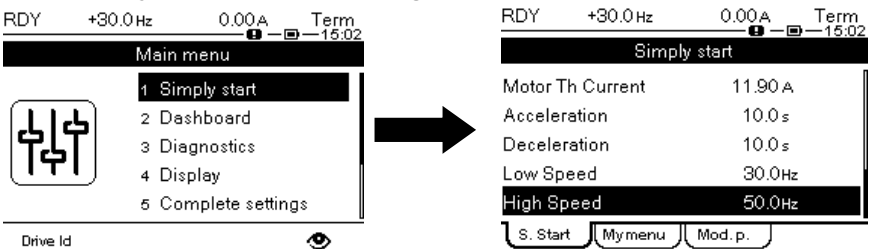
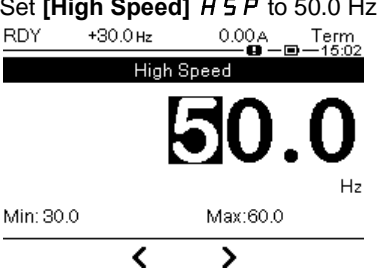
Step	Action
1	<p>Go to [Simply start] 5 9 5- menu, [Low Speed] L 5 P parameter</p>  <p>The first screenshot shows the 'Main menu' with options: 1 Simply start, 2 Dashboard, 3 Diagnostics, 4 Display, 5 Complete settings. The second screenshot shows the 'Simply start' menu with parameters: Motor Th Current (11.90 A), Acceleration (10.0 s), Deceleration (10.0 s), Low Speed (30.0 Hz), and High Speed (50.0 Hz). The 'Low Speed' parameter is highlighted.</p>
2	<p>Set [Low Speed] L 5 P to 30.0 Hz:</p>  <p>The screenshot shows the 'Low Speed' parameter set to 30.0 Hz. The range is Min: 0.0 and Max: 50.0 Hz. Navigation arrows are visible at the bottom.</p>
3	<p>Go to [Simply start] 5 9 5- menu, [High Speed] H 5 P parameter</p>  <p>The first screenshot shows the 'Main menu' with options: 1 Simply start, 2 Dashboard, 3 Diagnostics, 4 Display, 5 Complete settings. The second screenshot shows the 'Simply start' menu with parameters: Motor Th Current (11.90 A), Acceleration (10.0 s), Deceleration (10.0 s), Low Speed (30.0 Hz), and High Speed (50.0 Hz). The 'High Speed' parameter is highlighted.</p>
4	<p>Set [High Speed] H 5 P to 50.0 Hz:</p>  <p>The screenshot shows the 'High Speed' parameter set to 50.0 Hz. The range is Min: 30.0 and Max: 60.0 Hz. Navigation arrows are visible at the bottom.</p>

System Units Customization

Overview

The Altivar Process ATV600 drive offers the possibility to have customized units for your application.

You will have to set your pressure unit according to your application.

This menu is used to customize the following units:

- Pressure
- Flow
- Temperature
- Currency

Step by Step Configuration

The following table gives the step by step configuration of the System Units:

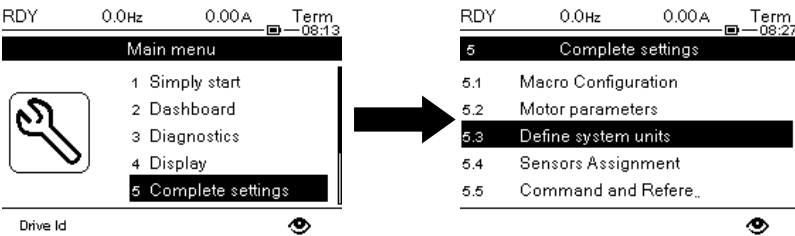
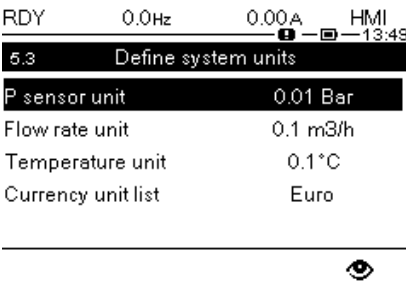
Step	Description
1	<p>Go to [Complete Settings] CSE- menu, [Define system units] SUC- submenu.</p>  <p>The first screenshot shows the 'Main menu' with options: 1 Simply start, 2 Dashboard, 3 Diagnostics, 4 Display, and 5 Complete settings. The second screenshot shows the 'Complete settings' submenu with options: 5.1 Macro Configuration, 5.2 Motor parameters, 5.3 Define system units, 5.4 Sensors Assignment, and 5.5 Command and Refere..</p>
2	<p>Set the following parameter values:</p> <ul style="list-style-type: none"> • [P sensor unit] S_{UPr}: [0.01 Bar] 001Bar • [Flow rate unit] S_{UFr}: [0.1 m3/h] 0103h • [Temperature unit] S_{UP}: [0.1°C] 01C • [Currency unit list] S_{UCu}: [Euro] Euro  <p>The screenshot shows the 'Define system units' menu with the following settings: P sensor unit: 0.01 Bar, Flow rate unit: 0.1 m3/h, Temperature unit: 0.1 °C, and Currency unit list: Euro.</p>

Command and Reference Value

Overview

The Altivar Process ATV600 drive offers several command and reference value channels.

This menu is used to customize these channels according to the application needs.

In this Application Note:

- On Master Drive, the reference value comes from the Graphic Display Terminal, and command comes from Terminal (Digital Input 1).
- On Slaves Drives, the factory setting configuration is used.

Step by Step Configuration

The following table gives the step by step configuration of the command and reference value parameters:

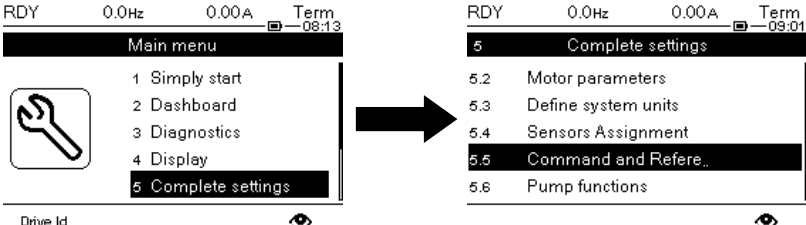
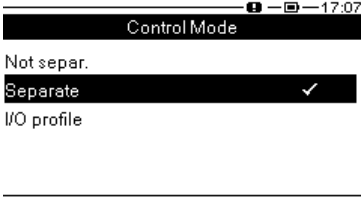
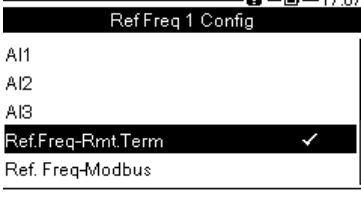
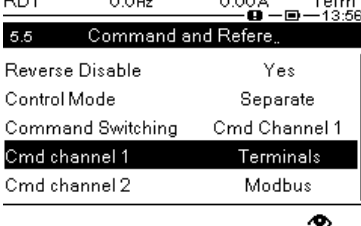
Step	Action
1	<p>On Master, go to [Complete Settings] C S E - menu, [Command and Reference] C R P - submenu.</p>  <p>RDY 0.0Hz 0.00A Term 08:13</p> <p>Main menu</p> <ul style="list-style-type: none"> 1 Simply start 2 Dashboard 3 Diagnostics 4 Display 5 Complete settings <p>Complete settings</p> <ul style="list-style-type: none"> 5.2 Motor parameters 5.3 Define system units 5.4 Sensors Assignment 5.5 Command and Refere.. 5.6 Pump functions <p>Drive Id</p>
2	<p>Set [Control Mode] C H C F to [Separte] S E P</p>  <p>RDY 0.0Hz 0.00A Term 17:07</p> <p>Control Mode</p> <p>Not separ.</p> <p>Separate ✓</p> <p>I/O profile</p>
3	<p>Set [Ref Freq 1 Config] F r I to [Ref.Freq-Rmt.term] L C C .</p>  <p>RDY 0.0Hz 0.00A Term 17:07</p> <p>Ref Freq 1 Config</p> <p>AI1</p> <p>AI2</p> <p>AI3</p> <p>Ref.Freq-Rmt.Term ✓</p> <p>Ref. Freq-Modbus</p>
4	<p>Set [Cmd channel 1] C d I to [Terminals] t E r</p>  <p>RDY 0.0Hz 0.00A Term 13:58</p> <p>5.5 Command and Refere..</p> <p>Reverse Disable Yes</p> <p>Control Mode Separate</p> <p>Command Switching Cmd Channel 1</p> <p>Cmd channel 1 Terminals</p> <p>Cmd channel 2 Modbus</p>

Ethernet Settings

Overview

MultiDrive Link feature of Altivar Process ATV600, equipped with VW3A3721 Ethernet modules, allows controlling the drives of your application using an Ethernet link between your drives.

The drives of an application have to be on the same Ethernet network.

NOTE: The Ethernet settings configuration can also be done automatically using a DHCP or a BOOTP server like a PLC.

Step by Step Configuration

The following table gives the step by step configuration for the Ethernet settings:

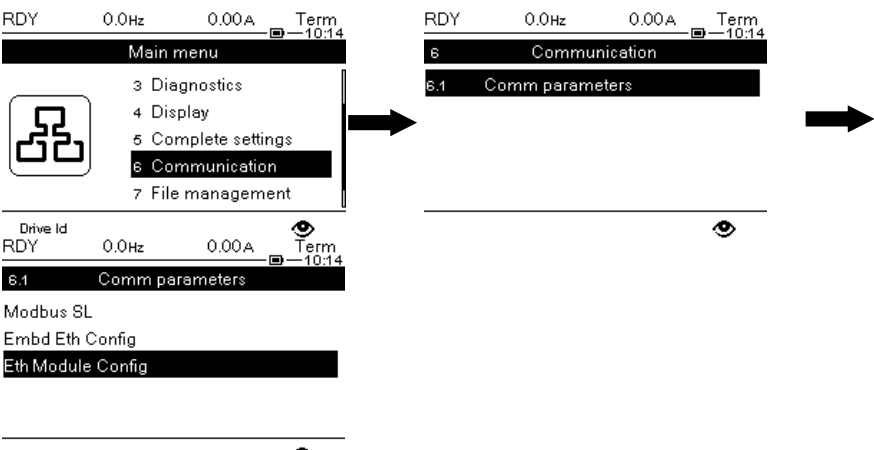
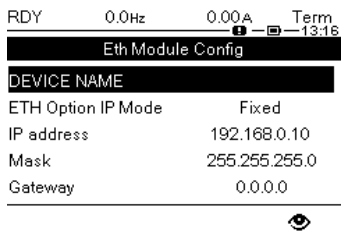
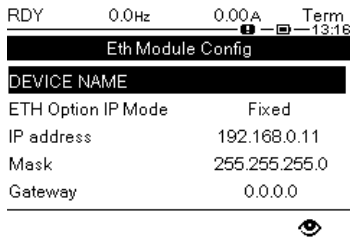
Step	Action
1	<p>Go to [Communication] <i>C O P</i> → [Comm parameters] <i>C P P</i> → [Eth Module Config] <i>E t o</i> menu</p>  <p>The diagram shows three screenshots of the drive's menu system. The first shows the 'Main menu' with options 3-7, where '6 Communication' is highlighted. An arrow points to the second screenshot, 'Communication', where '6.1 Comm parameters' is highlighted. A second arrow points to the third screenshot, 'Eth Module Config', which shows options like 'Modbus SL', 'Embd Eth Config', and 'Eth Module Config'.</p>
2	<p>On drive 1, configure the Ethernet settings:</p> <ul style="list-style-type: none"> • Set [ETH Option IP Mode] , <i>P I O</i> to [Fixed] <i>P A n u</i>, • Set [IP address] to 192.168.0.10 • Set [Mask] to 255.255.255.0 • Set [Gateway] to 0.0.0.0  <p>The screenshot shows the 'Eth Module Config' screen for drive 1. The 'DEVICE NAME' is redacted. The settings are: 'ETH Option IP Mode' is 'Fixed', 'IP address' is '192.168.0.10', 'Mask' is '255.255.255.0', and 'Gateway' is '0.0.0.0'.</p>
3	<p>On drive 2, configure the Ethernet settings:</p> <ul style="list-style-type: none"> • Set [ETH Option IP Mode] , <i>P I O</i> to [Fixed] <i>P A n u</i>, • Set [IP address] to 192.168.0.11 • Set [Mask] to 255.255.255.0 • Set [Gateway] to 0.0.0.0  <p>The screenshot shows the 'Eth Module Config' screen for drive 2. The 'DEVICE NAME' is redacted. The settings are: 'ETH Option IP Mode' is 'Fixed', 'IP address' is '192.168.0.11', 'Mask' is '255.255.255.0', and 'Gateway' is '0.0.0.0'.</p>

Step	Action
4	<p data-bbox="502 235 965 264">On drive 3, configure the Ethernet settings:</p> <ul data-bbox="502 302 949 465" style="list-style-type: none"> <li data-bbox="502 302 949 362">• Set [ETH Option IP Mode] to [Fixed] <li data-bbox="502 369 949 398">• Set [IP address] to 192.168.0.12 <li data-bbox="502 405 949 434">• Set [Mask] to 255.255.255.0 <li data-bbox="502 441 949 465">• Set [Gateway] to 0.0.0.0 <div data-bbox="1023 235 1390 488" style="border: 1px solid black; padding: 5px;"> <p data-bbox="1023 235 1390 264">RDY 0.0Hz 0.00A Term 13:18</p> <p data-bbox="1023 271 1390 300">Eth Module Config</p> <p data-bbox="1023 306 1390 336">DEVICE NAME</p> <p data-bbox="1023 342 1390 371">ETH Option IP Mode Fixed</p> <p data-bbox="1023 378 1390 407">IP address 192.168.0.12</p> <p data-bbox="1023 414 1390 443">Mask 255.255.255.0</p> <p data-bbox="1023 450 1390 479">Gateway 0.0.0.0</p> </div>
5	Restart the drives to take into account the Ethernet settings.

Sensor Assignment

Inlet Pressure Assignment

The following table gives the step by step configuration for the Inlet Pressure sensor:

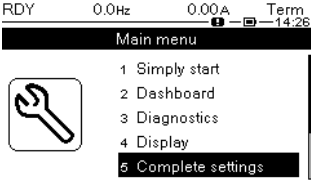
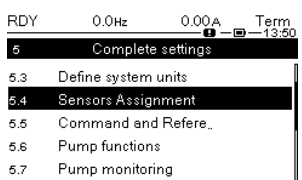
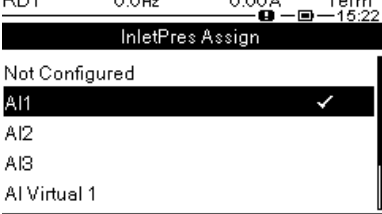
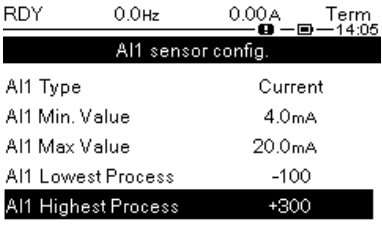
Step	Action
1	<p>On Master, go to [Complete setting] C 5 E → [Sensors Assignment] 5 5 C → [InletPres Assign] P 5 I R</p>   <p>RDY 0.0Hz 0.00A Term 14:26</p> <p>RDY 0.0Hz 0.00A Term 13:50</p> <p>Drive Id RDY 0.0Hz 0.00A Term 16:49</p> <p>5.4 Sensors Assignment</p> <p>InletPres Assign Not Configured</p> <p>OutletPres Assign Not Configured</p> <p>Inst. Flow Assign. Not Configured</p> <p>Pump Flow Assign. Not Configured</p>
2	<p>Set [InletPres Assign] P 5 I R to [AI1] R , I</p>  <p>RDY 0.0Hz 0.00A Term 15:22</p> <p>InletPres Assign</p> <p>Not Configured</p> <p>AI1 ✓</p> <p>AI2</p> <p>AI3</p> <p>AI Virtual 1</p>
3	<p>Configure the [AI1 sensor config.] , C R I :</p> <ul style="list-style-type: none"> • Set [AI1 Type] R , I E to [Current] D R • Set [AI1 Min.Value] C r L I to 4.0 mA • Set [AI1 Max Value] C r H I to 20.0 mA • Set [AI1 Lowest Process] R , I J to - 100 • Set [AI1 Highest Process] R , I K to 300  <p>RDY 0.0Hz 0.00A Term 14:05</p> <p>AI1 sensor config.</p> <p>AI1 Type Current</p> <p>AI1 Min. Value 4.0mA</p> <p>AI1 Max Value 20.0mA</p> <p>AI1 Lowest Process -100</p> <p>AI1 Highest Process +300</p>
<p>NOTE: The lowest and highest process values entered correspond to the minimum and maximum values of the sensor. As the sensor type used is a pressure sensor, the unit used in this example is 0.01 bar relative ([P sensor unit] 5 u P r).</p>	

Outlet Pressure Assignment

The following table gives the step by step configuration for the Outlet Pressure sensor:

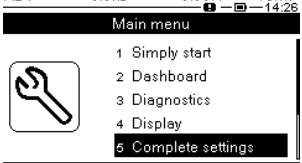
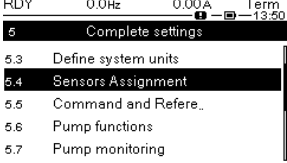
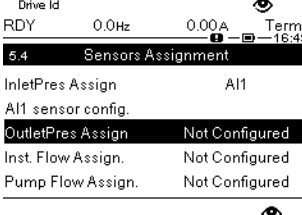
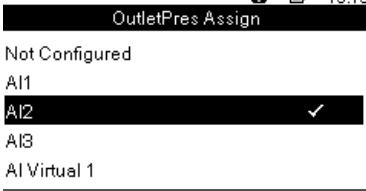
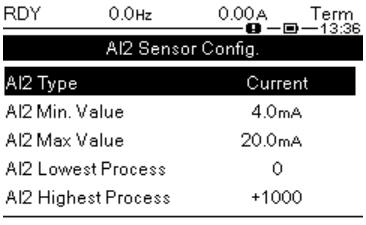
Step	Action
1	<p>On Master, go to [Complete setting] C 5 E → [Sensors Assignment] S 5 C → [OutletPres Assign] P 5 Z R</p>   
2	<p>Set [OutletPres Assign] P 5 Z R to [AI1] R 1 Z</p> 
3	<p>Configure the [AI2 sensor config.] I C R Z :</p> <ul style="list-style-type: none"> • Set [AI2Type] R 1 Z E to [Current] D R • Set [AI2 Min.Value] C r L Z to 4.0 mA • Set [AI2 Max Value] C r H Z to 20.0 mA • Set [AI2 Lowest Process] R 1 Z J to 0 • Set [AI2 Highest Process] R 1 Z K to 1000 
<p>NOTE: The lowest and highest process values entered correspond to the minimum and maximum values of the sensor. As the sensor type used is a pressure sensor, the unit used in this example is 0.01 bar relative ([P sensor unit] S u P r).</p>	

Installation Flow Assignment

The following table gives the step by step configuration for the Installation Flow sensor:

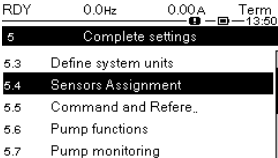
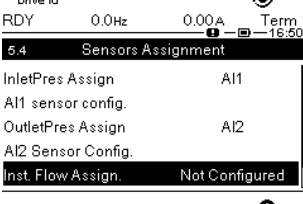
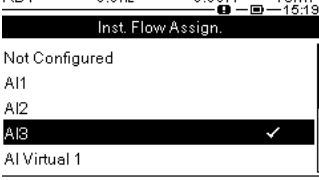
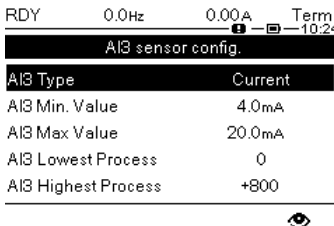
Step	Action
1	<p>On Master, go to [Complete setting] C 5 E → [Sensors Assignment] 5 5 C → [Inst. Flow Assign.] F 5 I A</p>   
2	<p>Set [Inst. Flow Assign] F 5 I A to [AI3] A , 3</p> 
3	<p>Configure the [AI3 Sensor Config.] b , F 3 configure the parameters:</p> <ul style="list-style-type: none"> • Set [AI3 Type] A , 3 E to [Current] 0 A • Set [AI3 Min. Value] C r L 3 to 4.0 mA • Set [AI3 Max Value] C r H 3 to 20.0 mA • Set [AI3 Lowest Process] A , 3 J to 0 • Set [AI3 Highest Process] A , 3 J to 800 
<p>NOTE: The lowest and highest process values entered correspond to the minimum and maximum values of the sensor. As the sensor type used is a flow sensor, the unit used in this example is 0.1m³/h ([Flow rate unit] 5 u F r).</p>	

Pump Characteristics

Overview

In order to use the Booster Control Optimized, you have to configure the pump characteristics.

For Booster Control Optimized, we use the Power, Head and Flow characteristics. These data are supplied by the pump manufacturer and are necessary to know the performances of a pump at a given speed.

For further information, you can refer to the ATV600 Programming Manual.

Step by Step Configuration

The following table gives the step by step configuration for the pump characteristics:

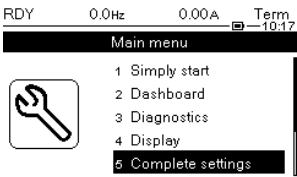
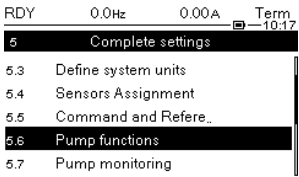
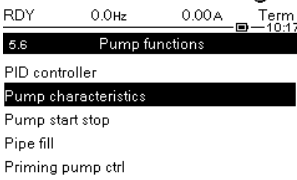
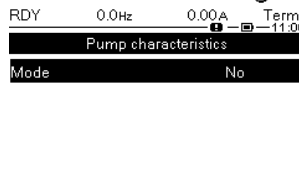
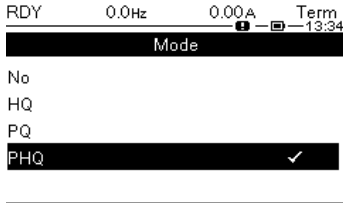
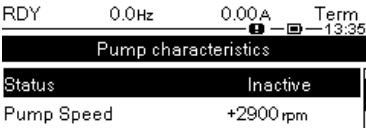
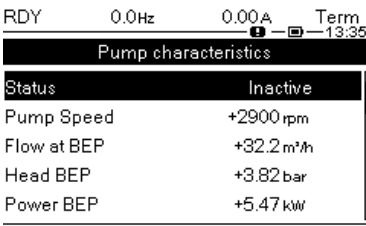
Step	Action
1	<p>Go to [Complete settings] C S t → [Pump functions] P F t → [Pump characteristics] P C r</p>    
2	<ul style="list-style-type: none"> Set [Mode] P C n to [PHQ] P H q 
3	<ul style="list-style-type: none"> Set [Pump Speed] P C S P to 2900 rpm 
4	<ul style="list-style-type: none"> Set [Flow at BEP] P C b q to 32.2 m³/h Set [Head BEP] P C b H to 3.82 bar Set [Power BEP] P C b P to 5.47 kW 

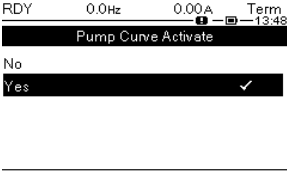
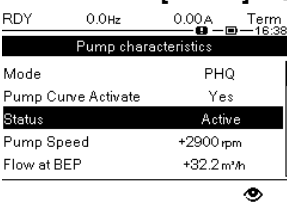
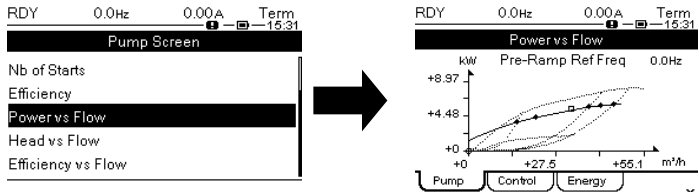
Step	Action
5	Repeat the step 4) for the 5 points: <ul style="list-style-type: none"> • [Flow 1] P C 9 1 to [Flow 5] P C 9 5 • [Head 1] P C H 1 to [Head 5] P C H 5 • [Power 1] P C P 1 to [Power 5] P C P 5
6	Set [Pump Curve Activate] P C A to [Yes] Y E 5 
7	Check that the [Status] P C S is set to [Active] A C T I V E  <p>NOTE : If the [Status] P C S is set to [Failed] F A I L E d, verify that your data are consistent</p>
8	Go to [Dashboard] d 5 H menu
9	On pump tab : , <ul style="list-style-type: none"> • press F4, • Select Power vs Flow, • Ensure that the displayed curve is consistent to your pump manufacturer curves. 
10	Repeat the step 9) with the: <ul style="list-style-type: none"> • Head vs Flow, • Efficiency vs Flow

Head Correction

Overview

This function is necessary to allow the estimation of the head of the pump using the predefined pump characteristics. The pump curves shall be set in the pump characteristics functions before setting the head estimation.

In this application note, we use the dP/Head Correction in order to determine the Head from the dP measurement.

It is necessary to calibrate the function with:

- **[Head Dynamic Gain] H_{EG}** : this parameter allows adjusting the head estimation close to the real head at pump high flow.
- **[Head Static Offset] H_{EO}** : this parameter corresponds to the geometrical height between inlet and outlet pressure sensors. The value can be calculated as follows:

$$H_{EO} = \frac{H_{GEO}}{H_{BEP}} \times 100$$

With H_{GEO} = Outlet pressure sensor's geometrical height – Inlet pressure sensor's geometrical height (converted according **[P sensor unit] S_{UP}**).

And H_{BEP} = **[Head BEP] P_{CBH}**

NOTE: If both sensors are installed at the same geometrical height, this parameter can be set to 0.

To calibrate the function, two methods are available:

- **Correction according to the nominal pump curve** (when there is possibility to modify the system curve with a valve).
- **Correction according to a system curve** (when there is no possibility to modify the system curve with a valve).

NOTE: This procedure has to be performed on each drive of the application, one by one. During this procedure, the installation flow sensor is used temporarily as pump flow sensor.

Correction according to the nominal pump curve

The following table gives the step by step configuration for the Head Correction at nominal speed using a valve:

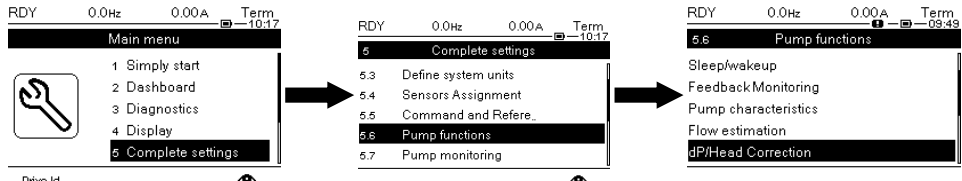
Step	Action
1	Go to [Complete setting] CSE → [Sensors Assignment] $S5C$ → [Pump Flow Assign.] $F52A$
2	Set [Pump Flow Assign.] $F52A$ to [AI3] R, E
3	Go to [Complete settings] CSE → [Pump functions] PFE → [Booster Control] $b5E$ menu → [Booster Control] $b5C$ tab → [dP/Head Correction] $dPHC$ menu 
4	Run the pump at its nominal speed with the valve nearly closed.

Step	Action
5	Adjust, if necessary, the [Head Static Offset] H E O in order to have the point on the curve using the [Head vs Flow] C H 9 curve in the [Dashboard] d 5 H menu. NOTE: The value obtained can be compared with the result of the calculation.
6	Run the pump at its nominal speed with the valve opened.
7	Adjust, if necessary, the [Head Dynamic Gain] H E G in order to have the point on the curve using the [Head vs Flow] C H 9 curve in the [Dashboard] d 5 H menu.
8	Un-configure by setting the [Pump Flow Assign.] F 5 2 A to [Not assigned] n o .
9	Repeat this procedure on each drive of the application.

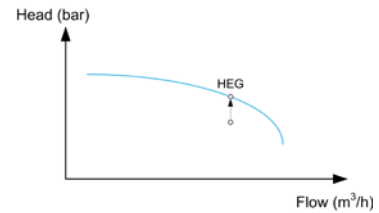
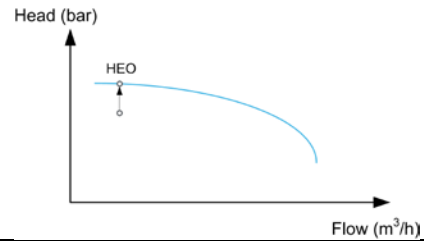

Correction according to a system curve

The following table gives the step by step configuration for the Head Correction at variable speed using no valve:

Step	Action
1	Go to [Complete setting] C 5 E → [Sensors Assignment] S 5 C → [Pump Flow Assign.] F 5 2 A
2	Set [Pump Flow Assign.] F 5 2 A to [AI3] A , 3
3	Go to [Complete settings] C 5 E → [Pump functions] P F E → [Booster Control] b 5 E menu → [Booster Control] b 5 C tab → [dP/Head Correction] d P H C menu
4	Set the [Head Static Offset] H E O according to the formula above
5	On a stabilized system, run the pump at its maximum speed.
6	Adjust, if necessary the [Head Dynamic Gain] H E G in order to have the point on the curve using the [Head vs Flow] C H 9 curve in the [Dashboard] d 5 H menu.
7	Un-configure by setting the [Pump Flow Assign.] F 5 2 A to [Not assigned] n o .
8	Repeat this procedure on each drive of the application.

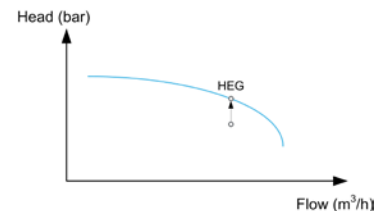
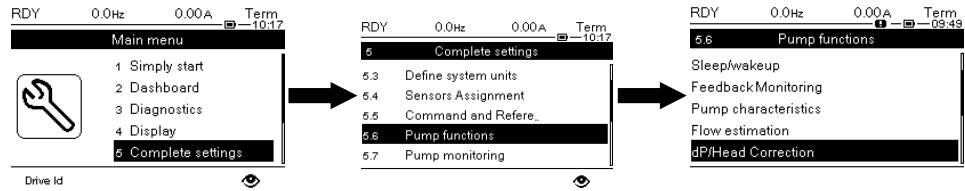

Part IV

MultiPump Configuration

Introduction

This part describes the steps to perform in order to use the MultiDrive Link feature of Altivar Process ATV600.

The values of parameters given in this part correspond to the Multi Drives architecture selected for this Application Note.

NOTE: Settings may vary according to the architecture needs.

What is in This Part?

This part contains the following topics:

Pump System Architectures	40
MultiDrive Link Configuration.....	41

Pump System Architectures

Overview

The Altivar Process ATV600 drive can be used in several pumps architectures.

This menu is used to select and configure one of the following architectures:

- Single Drive: one Altivar Process ATV600 and up to 5 fixed speed pumps.
- Multi Drives: one Master Altivar Process ATV600 and up to 5 Slaves Altivar Process ATV600.
- Multi Masters: Up to 6 Altivar Process ATV600 that can act as Masters or Slaves.

In this Application Note, the selected architecture is Multi Drives.

Step by Step Configuration

The following table gives the step by step configuration for the selection of Pump System Architecture:

Step	Action
1	<p>Go to [Complete settings] C 5 L → [Pump functions] P F L → [Booster Control] b 5 L → [System architecture] P P 9 menu</p> <p>RDY 0.0Hz 0.00A Term -10:17</p> <p>RDY 0.0Hz 0.00A Term -10:17</p> <p>RDY 0.0Hz 0.00A Term -16:31</p> <p>RDY 0.0Hz 0.00A Term -15:46</p>
2	<p>Set [Pump System Architecture] P P 5 A to [Multi Drives] n V 5 d</p> <p>RDY 0.0Hz 0.00A Term -10:42</p>

MultiDrive Link Configuration

Overview

The MultiDrive Link needs to be configured on each drive to define if the device in the application acts as Master or Slave.

In this Application Note, one drive acts as Master and two drives act as Slaves.

Master Step by Step Configuration

The following table gives the step by step configuration of the MultiDrive Link on **Master**:

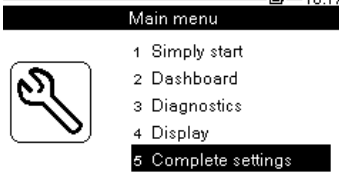
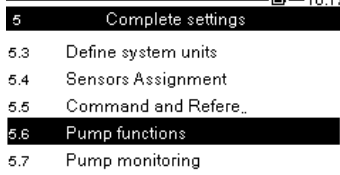
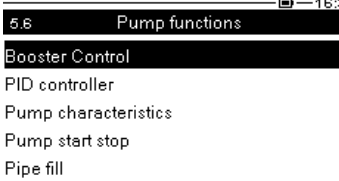
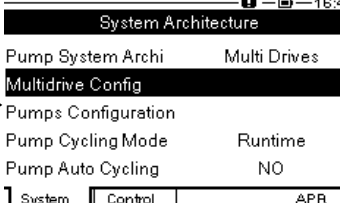
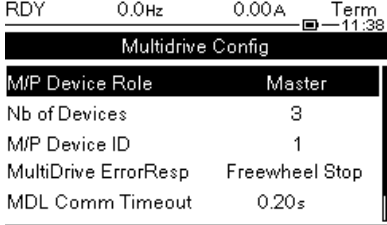
Step	Action
1	<p>Go to [Complete settings] <i>CLSE</i> → [Pump functions] <i>PFLE</i> → [Booster Control] <i>BSLE</i> → [System architecture] <i>PP9</i> → [Multidrive Config] <i>PPV</i> menu</p>    
2	<p>Configure the parameters:</p> <ul style="list-style-type: none"> • Set [M/P Device Role] <i>PPdE</i> to [Master] <i>PPASL</i>, • Set [Nb of Devices] <i>PPGn</i> to 3, • Set [M/P Device ID] <i>PPGid</i> to 1. 

Slaves Step by Step Configuration

The following table gives the step by step configuration of the MultiDrive Link on **Slaves**:

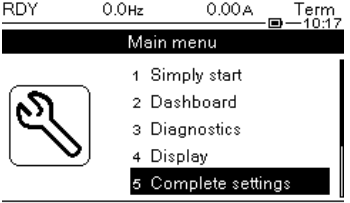
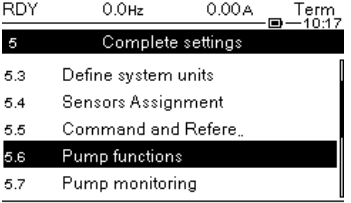
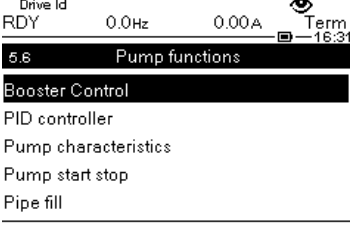
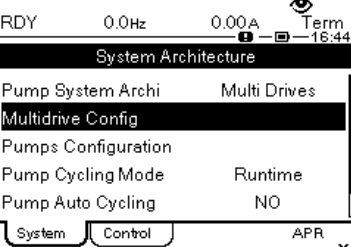
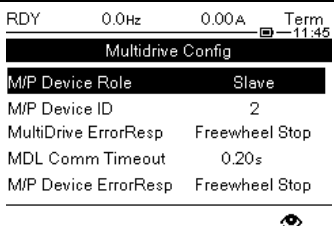
Step	Action
1	<p>Go to [Complete settings] <i>CLSE</i> → [Pump functions] <i>PFL</i> → [Booster Control] <i>BSL</i> → [System architecture] <i>PP9</i> → [Multidrive Config] <i>PPVL</i> menu</p>    
2	<p>Configure the parameters:</p> <ul style="list-style-type: none"> • Set [M/P Device Role] <i>PPdL</i> to [Slave] <i>SLAVE</i>, • Set [M/P Device ID] <i>PPid</i> to 2. 
3	<p>Repeat the operation on the other Slaves by incrementing the [M/P Device ID] <i>PPid</i> value.</p>

Part V

Booster Control Configuration

Introduction

This part describes the steps to perform in order to configure the Booster Control Optimized application.

The values of parameters given in this part correspond to the architecture selected for this Application Note.

NOTE: Settings may vary according to the architecture needs.

What is in This Part?

This part contains the following topics:

Booster Control Activation	44
Type of Control Configuration.....	45
Stage / Destage Condition	46
PID Controller.....	47
Start the Application	49

Booster Control Activation

Overview

This menu allows activating the Booster Control function on Altivar Process ATV600.

When you activate this function, a message informs you to configure the PID controller. This configuration will be done in a next part.

Step-by-Step Configuration

The following table gives the step by step configuration of the Booster Control Activation:

Step	Action
1	<p>On Master go to [Complete settings] C 5 E → [Pump functions] P F E → [Booster Control] b 5 E menu → [Booster Control] b 5 C tab:</p> <p>The sequence of screenshots shows the navigation from the Main menu to Complete settings, then to Pump functions, then to the Booster Control tab, and finally selecting 'Yes' to activate the function.</p>
2	<p>Set [Booster Control] b 5 C to [Yes] Y E S:</p> <p>The screenshot shows the 'Booster Control' menu with 'Yes' selected and a checkmark next to it.</p>
3	<p>A message informing you to check the PID controller configuration is displayed.</p> <p>The screenshot shows the 'Booster Control' menu with the message 'Check PID controller configuration.' displayed.</p> <p>Press “OK” on the Graphic Display Terminal to confirm.</p>

Type of Control Configuration

Overview

This parameter allows defining the type of control of the booster.

In this application note, the type of control is on pressure.

Step-by-Step Configuration

The following table gives the step by step configuration for the Type of Control Configuration:

Step	Action
1	<p>On Master go to [Complete settings] C S E → [Pump functions] P F E → [Booster Control] b S E menu → [Booster Control] b S C tab</p>
2	<p>Configure the parameters:</p> <ul style="list-style-type: none"> • Set [Type of control] E O C E to [PRESSURE] P R E S S • Set [M/P speed Mode] N P S E to [Advanced] A N C

Stage / Destage Condition

Overview

These parameters allow defining the condition of staging / destaging.

In this application note, the stage / destage condition is Energy Optimized.

The stage and destage delays are the durations for which the staging / destaging condition must remain present before it is taken into account.

Step by Step Configuration

The following table gives the step by step configuration for the Stage / Destage Condition:

Step	Action
1	<p>On Master go to [Complete settings] C S E → [Pump functions] P F E → [Booster Control] b S E menu → [Booster Control] b S C tab [Stage/Destage Cond.] S d C n</p>
2	<p>Configure the parameters:</p> <ul style="list-style-type: none"> Set [Boost S/D Condition] b S d C to [Energy Optimized] o P E Check the configuration [Inst. Flow Assign.] F S I A previously assigned to [AI3] A , 3 Set [Booster Stg Delay] b S d to 5.0 s Set [Booster Dstg Delay] b d d to 5.0 s

PID Controller

Overview

This function is activated by assigning an analog input to the PID feedback. To configure the PID, you have to scale the minimum and maximum reference values according to your application.

In this application note, we use the analog input 2 as feedback. The minimum PID feedback is set to 0.00 bar and the maximum PID reference value is set to 10.00 bar.

The PID controller has to be configured and wired on the Master.

Step-by Step Configuration

The following table gives the step by step configuration for the PID Controller:

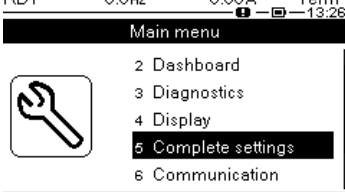
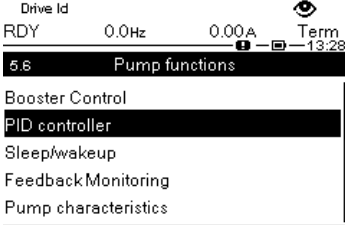
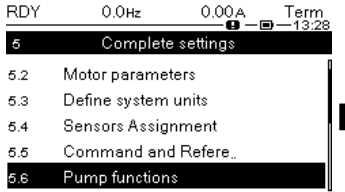
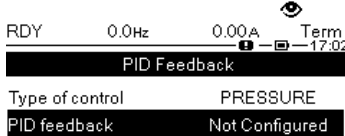
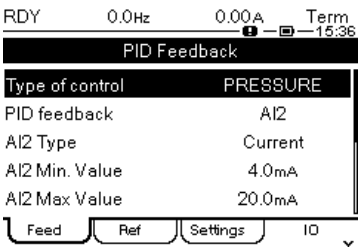
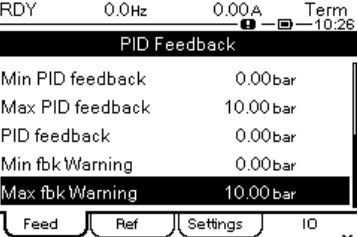
Step	Action
1	<p>Go to [Complete settings] C S E → [Pump functions] P F E → [PID controller] P I D menu [PID Feedback] P I F tab</p>    
2	Set [PID feedback] P I F to [AI2] A I 2
3	<p>Check the Analog Input 2 configuration:</p> <ul style="list-style-type: none"> • [AI2 Type] A I 2 E : [Current] D A • [AI2 Min. Value] C F L 2 : 4.0 mA • [AI2 Max Value] C F H 2 : 20.0 mA • [Min PID feedback] P I F I : 0.00 bar • [Max PID feedback] P I F 2 : 10.00 bar  
4	<p>Adjust feedback warning according to the application need. In this application we do not use it. The minimum and maximum are set to the sensor limits:</p> <ul style="list-style-type: none"> • Set [Min fbk Warning] P F L to 0.00 bar • Set [Max fbk Warning] P F H to 10.00 bar

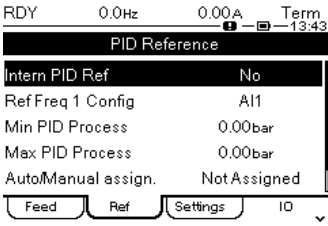
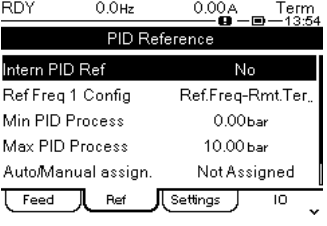
Step	Action
5	<p>Go to [PID Reference] <i>r F</i> tab</p> 
6	<p>Configure the parameters:</p> <ul style="list-style-type: none"> • Set [Intern PID Ref] <i>P 1 1</i> to [No] <i>n o</i> • Set [Ref Freq 1 Config] <i>F r 1</i> to [Ref.Freq-Rmt.Term] <i>L L C</i> • Set [Min PID Process] <i>P 1 P 1</i> to 0.00 bar • Set [Max PID Process] <i>P 1 P 2</i> to 10.00 bar <p>NOTE: The lowest and highest process values entered correspond to the minimum and maximum values of the PID controller.</p> 

Start the Application

Check the Application

Before starting the application, you have to check the parameters configuration in the Display menu.

The following table gives the step by step configuration to check the application:

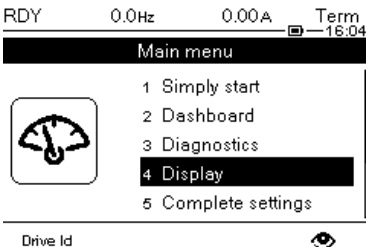
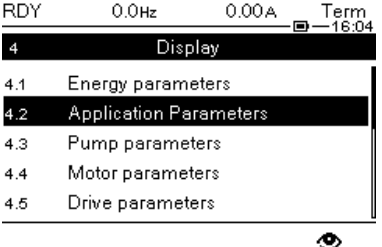
Step	Action												
1	<p>On Master, go to [Display] $\Pi \square \square \rightarrow$ [Application Parameters] $PP r$ menu</p>   <p>RDY 0.0Hz 0.00A Term -16:04</p> <p>Main menu</p> <ol style="list-style-type: none"> 1 Simply start 2 Dashboard 3 Diagnostics 4 Display 5 Complete settings <p>Drive Id </p> <p>RDY 0.0Hz 0.00A Term -16:04</p> <p>4 Display</p> <ol style="list-style-type: none"> 4.1 Energy parameters 4.2 Application Parameters 4.3 Pump parameters 4.4 Motor parameters 4.5 Drive parameters <p></p>												
2	<p>Check the state of the following parameters:</p> <table border="1" data-bbox="730 857 1465 1234"> <thead> <tr> <th>Setting</th> <th>Verify that...</th> </tr> </thead> <tbody> <tr> <td>[System App State] $PP S S$</td> <td>The state is [Stop]. No run order on Master or Slaves</td> </tr> <tr> <td>[Application state] $PP P S$</td> <td>The state is [Stop]. No run order on the current device.</td> </tr> <tr> <td>[Booster Status] $b C S$</td> <td>The state is [Inactive]</td> </tr> <tr> <td>[PID reference] $r P C$</td> <td>The reference value is consistent according to the application</td> </tr> <tr> <td>[PID Feedback] $r P F$</td> <td>The feedback value is consistent according to the application.</td> </tr> </tbody> </table>	Setting	Verify that...	[System App State] $PP S S$	The state is [Stop] . No run order on Master or Slaves	[Application state] $PP P S$	The state is [Stop] . No run order on the current device.	[Booster Status] $b C S$	The state is [Inactive]	[PID reference] $r P C$	The reference value is consistent according to the application	[PID Feedback] $r P F$	The feedback value is consistent according to the application.
Setting	Verify that...												
[System App State] $PP S S$	The state is [Stop] . No run order on Master or Slaves												
[Application state] $PP P S$	The state is [Stop] . No run order on the current device.												
[Booster Status] $b C S$	The state is [Inactive]												
[PID reference] $r P C$	The reference value is consistent according to the application												
[PID Feedback] $r P F$	The feedback value is consistent according to the application.												

Check the Pump Parameters

Before starting the application, you have to check the parameters configuration in the Display menu.

The following table gives the step by step configuration to check the pump parameters:

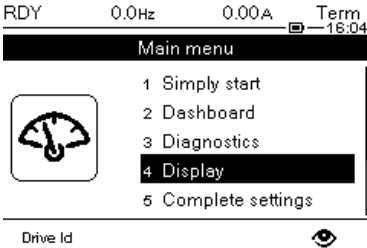
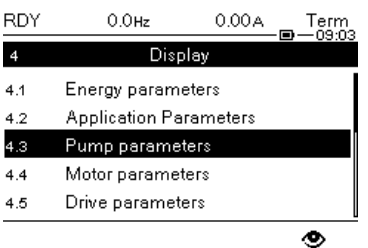
Step	Action																				
1	<p>On Master, go to [Display] Π P 5 → [Pump parameters] P P r menu [Multipump System] Π P 5 tab</p>  																				
2	On Slave 1 and Slave 2, give a run order.																				
3	<p>Check the state of the following parameters:</p> <table border="1" data-bbox="694 817 1428 1467"> <thead> <tr> <th>Setting</th> <th>Verify that...</th> </tr> </thead> <tbody> <tr> <td>[MultiPump State] Π P 5</td> <td>The state is [Ready]</td> </tr> <tr> <td>[Available Pumps] Π P Π n</td> <td>The number of available pumps is 3</td> </tr> <tr> <td>[Number of Staged Pump] Π P 5 n</td> <td>There is no staged pump</td> </tr> <tr> <td>[Pump 1 State] P 1 S</td> <td>The state is [Ready]</td> </tr> <tr> <td>[Pump 1 Type] P 1 E</td> <td>The state is [Auxiliary Variable]</td> </tr> <tr> <td>[Pump 2 State] P 2 S</td> <td>The state is [Ready]</td> </tr> <tr> <td>[Pump 2 Type] P 2 E</td> <td>The state is [Auxiliary Variable]</td> </tr> <tr> <td>[Pump 3 State] P 3 S</td> <td>The state is [Ready]</td> </tr> <tr> <td>[Pump 3 Type] P 3 E</td> <td>The state is [Auxiliary Variable]</td> </tr> </tbody> </table>	Setting	Verify that...	[MultiPump State] Π P 5	The state is [Ready]	[Available Pumps] Π P Π n	The number of available pumps is 3	[Number of Staged Pump] Π P 5 n	There is no staged pump	[Pump 1 State] P 1 S	The state is [Ready]	[Pump 1 Type] P 1 E	The state is [Auxiliary Variable]	[Pump 2 State] P 2 S	The state is [Ready]	[Pump 2 Type] P 2 E	The state is [Auxiliary Variable]	[Pump 3 State] P 3 S	The state is [Ready]	[Pump 3 Type] P 3 E	The state is [Auxiliary Variable]
Setting	Verify that...																				
[MultiPump State] Π P 5	The state is [Ready]																				
[Available Pumps] Π P Π n	The number of available pumps is 3																				
[Number of Staged Pump] Π P 5 n	There is no staged pump																				
[Pump 1 State] P 1 S	The state is [Ready]																				
[Pump 1 Type] P 1 E	The state is [Auxiliary Variable]																				
[Pump 2 State] P 2 S	The state is [Ready]																				
[Pump 2 Type] P 2 E	The state is [Auxiliary Variable]																				
[Pump 3 State] P 3 S	The state is [Ready]																				
[Pump 3 Type] P 3 E	The state is [Auxiliary Variable]																				

Start the Drives

Once the checking of the application is done, you can start the application

The following table gives the step by step configuration to start the application:

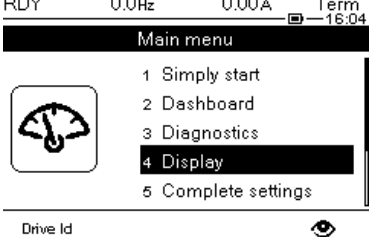
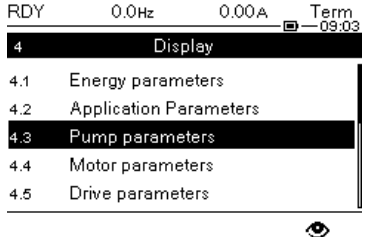
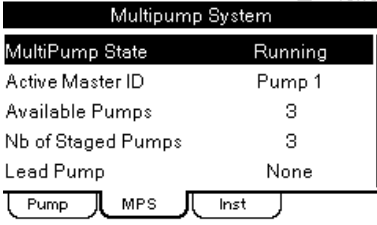
Step	Action
1	On Master, give the run order
2	On Master, go to [Display] P P N → [Pump parameters] P P r menu [Multipump System] P P S tab  
3	Check that [MultiPump State] P P S state is set to [Running] r u n 
4	Perform a cycle to check that the application is working properly

Verify the Staging / Destaging Operation

During operation, if there are many stages / destages, you can configure the **[Booster S/D Flow Hyst] b 5 d H**

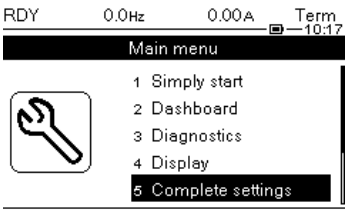
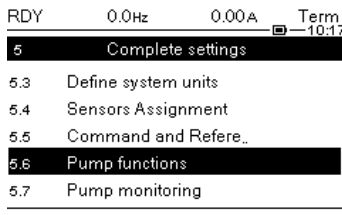
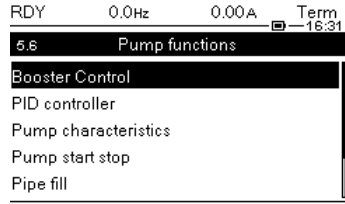
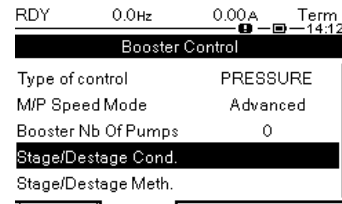
Step	Action
1	On Master, go to [Complete settings] C 5 t → [Pump functions] P F t → [Booster Control] b 5 t menu → [Booster Control] b 5 C tab [Stage/Destage Cond.] 5 d C N    
2	Increase the [Booster S/D Flow Hyst] b 5 d H to avoid repetitive stages / destages.

Part VI

Additional Parameters

Introduction

This part describes the additional steps that can be achieved to optimize the Booster Control application behavior.

In factory settings configuration, these parameters allow standard working on the application.

The values of parameters given in this part are given as example with their effects on the application.

NOTE: Settings may vary according to the architecture needs.

What is in This Part?

This part contains the following topics:

MultiDrive Link – Errors & Warning Handling	53
System Architecture – Pumps Configuration	55
System Architecture – Pump Cycling Parameters	56

MultiDrive Link – Errors & Warning Handling

Overview

It is possible to configure the response to errors that the drives can detect on the MultiDrive Link architecture.

It is also possible to configure the MultiDrive Link communication timeout according to the network load of the application.

By default, these error responses are set to ramp stop to avoid water hammer effect.

In this configuration example, the error responses are changed to freewheel stop and the timeout is set to 0.20 s.

A **[MultiDrive Link Error] $\Pi d L F$** error is active if the MultiDrive Link architecture is not consistent (several Masters, several Slaves with same ID) at run command. The drive response to a **[MultiDrive Link Error] $\Pi d L F$** is set with **[MultiDrive ErrorResp] $\Pi d L b$** parameter.

The **[M/P Device Error] $\Pi P d F$** error can be active only on a device which acts as a Slave. The drive response to a **[M/P Device Error] $\Pi P d F$** is set with **[M/P Device ErrorResp] $\Pi P d b$** parameter.

Master Configuration

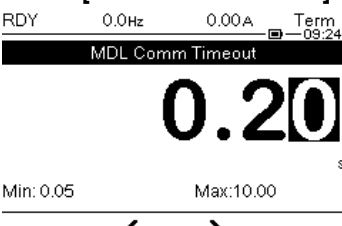

The following table gives the step by step configuration on Master for the MultiDrive Link errors and warning:

Step	Action
1	<p>Go to [Complete settings] $C S E$ → [Pump functions] $P F E$ → [Booster Control] $b S E$ → [System architecture] $\Pi P q$ → [Multidrive Config] $\Pi P V C$ menu, [MultiDrive ErrorResp] $\Pi d L b$ parameter:</p>
2	<p>Set [MultiDrive ErrorResp] $\Pi d L b$ to [Freewheel Stop] $n S E$</p>

Step	Action
3	<p>Set the [MDL Comm Timeout] <i>MDL</i> to 0.20 s</p>  <p>RDY 0.0Hz 0.00A Term 09:24</p> <p>MDL Comm Timeout</p> <p>0.20 s</p> <p>Min: 0.05 Max: 10.00</p> <p>< ></p>

Slaves Configuration

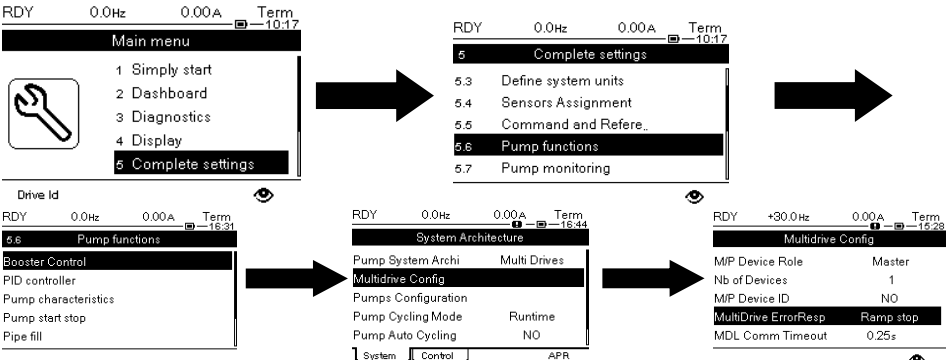
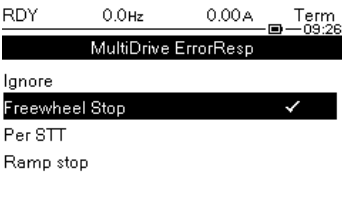
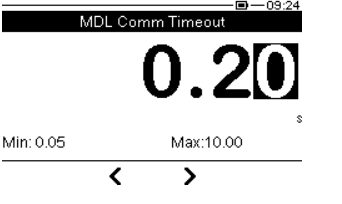
The following table gives the step by step configuration on Slaves for the MultiDrive Link errors and warning:

Step	Action
1	<p>Go to [Complete settings] <i>CSE</i> → [Pump functions] <i>PF</i> → [Booster Control] <i>BSE</i> → [System architecture] <i>PPA</i> → [Multidrive Config] <i>PPVC</i> menu, [MultiDrive ErrorResp] <i>MDL</i> parameter:</p>  <p>RDY 0.0Hz 0.00A Term 10:17</p> <p>Main menu</p> <p>1 Simply start</p> <p>2 Dashboard</p> <p>3 Diagnostics</p> <p>4 Display</p> <p>5 Complete settings</p> <p>RDY 0.0Hz 0.00A Term 10:17</p> <p>5 Complete settings</p> <p>5.3 Define system units</p> <p>5.4 Sensors Assignment</p> <p>5.5 Command and Refere..</p> <p>5.6 Pump functions</p> <p>5.7 Pump monitoring</p> <p>Drive Id</p> <p>RDY 0.0Hz 0.00A Term 10:21</p> <p>5.6 Pump functions</p> <p>Booster Control</p> <p>PID controller</p> <p>Pump characteristics</p> <p>Pump start stop</p> <p>Pipe fill</p> <p>RDY 0.0Hz 0.00A Term 10:44</p> <p>System Architecture</p> <p>Pump System Archi Multi Drives</p> <p>Multidrive Config</p> <p>Pumps Configuration</p> <p>Pump Cycling Mode Runtime</p> <p>Pump Auto Cycling NO</p> <p>System Control APR</p> <p>RDY +30.0Hz 0.00A Term 10:28</p> <p>Multidrive Config</p> <p>M/P Device Role Master</p> <p>Nb of Devices 1</p> <p>M/P Device ID NO</p> <p>MultiDrive ErrorResp Ramp stop</p> <p>MDL Comm Timeout 0.25s</p>
2	<p>Set [MultiDrive ErrorResp] <i>MDL</i> to [Freewheel Stop] <i>n5</i></p>  <p>RDY 0.0Hz 0.00A Term 09:26</p> <p>MultiDrive ErrorResp</p> <p>Ignore</p> <p>Freewheel Stop ✓</p> <p>Per STT</p> <p>Ramp stop</p>
3	<p>Set the [MDL Comm Timeout] <i>MDL</i> to 0.20 s</p>  <p>RDY 0.0Hz 0.00A Term 09:24</p> <p>MDL Comm Timeout</p> <p>0.20 s</p> <p>Min: 0.05 Max: 10.00</p> <p>< ></p>
4	<p>Set [M/P Device ErrorResp] <i>MPD</i> to [Freewheel Stop] <i>n5</i></p>  <p>RDY 0.0Hz 0.00A Term 09:26</p> <p>M/P Device ErrorResp</p> <p>Ignore</p> <p>Freewheel Stop ✓</p> <p>Per STT</p> <p>Ramp stop</p>

System Architecture – Pumps Configuration

Overview

For maintenance purpose, you can interlock a pump locally by activating a digital input.

In this configuration example, a pump will be not available if the digital input DI3 is inactive.

Steps by Step Configuration

The following table gives the step by step configuration for the Pumps on each drive:

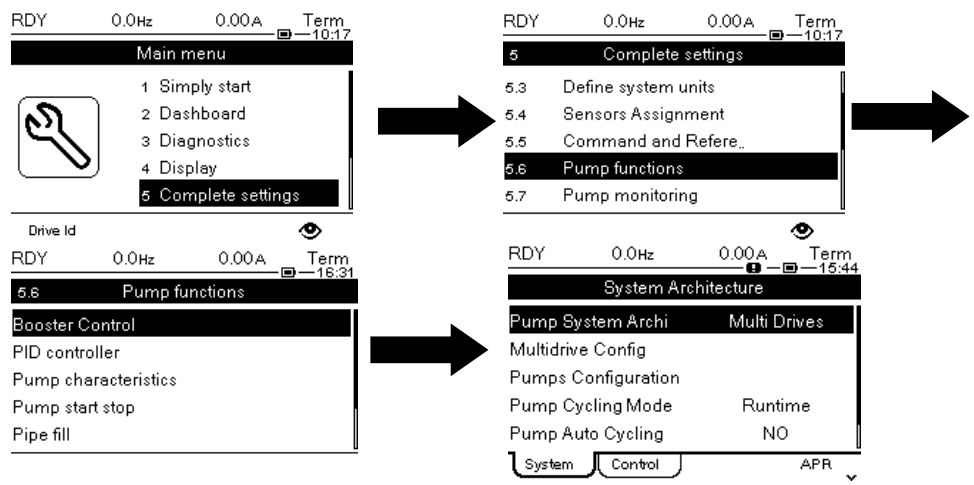
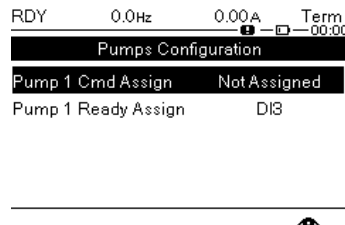
Step	Action
1	<p data-bbox="499 645 1477 705">Go to [Complete settings] <i>L 5 L</i> → [Pump functions] <i>P F L</i> → [Booster Control] <i>b 5 L</i> → [System architecture] <i>Π P 9</i> → [Pump Configuration] <i>P ∩ Π P</i> menu</p>  <p>The screenshot sequence shows the following steps:</p> <ul style="list-style-type: none"> Main menu: Options include Simply start, Dashboard, Diagnostics, Display, and Complete settings (highlighted). Complete settings: Options include Define system units, Sensors Assignment, Command and Refere., Pump functions (highlighted), and Pump monitoring. Pump functions: Options include Booster Control (highlighted), PID controller, Pump characteristics, Pump start stop, and Pipe fill. System Architecture: Options include Pump System Archi, Multi Drives, Multidrive Config, Pumps Configuration, Pump Cycling Mode (Runtime), and Pump Auto Cycling (NO).
2	<p data-bbox="499 1220 1477 1243">Set [Pump 1 Ready Assign] <i>Π P , I</i> to [DI3] <i>L , 3</i>.</p>  <p>The screenshot shows the Pumps Configuration menu with the following settings:</p> <ul style="list-style-type: none"> Pump 1 Cmd Assign: Not Assigned Pump 1 Ready Assign: DI3 <p>NOTE : The [Pump 1 Cmd Assign] <i>Π P ∩ I</i> is mainly used for Single Drive architecture.</p>

System Architecture – Pump Cycling Parameters

Overview

This functionality allows changing the start order of the available pumps in order to manage their wear.

In this configuration example, the cycling mode is based on running time. The available pump with the lowest running time is started first and the running pump with the highest running time is stopped first.

Step by Step Configuration

The following table gives the step by step configuration for the Pump Cycling Parameters:

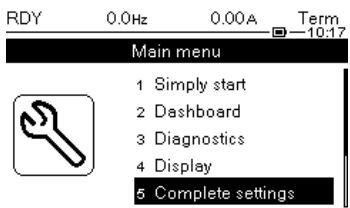
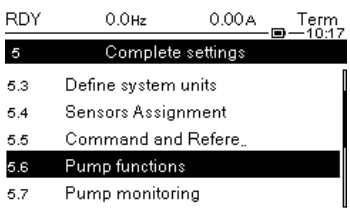
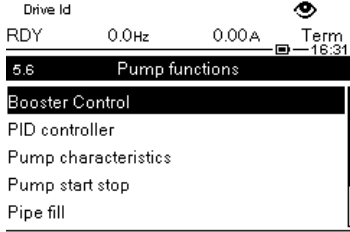
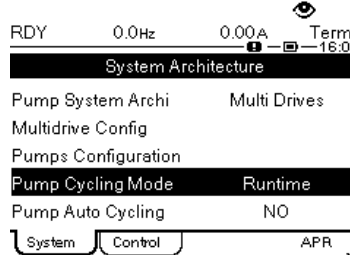
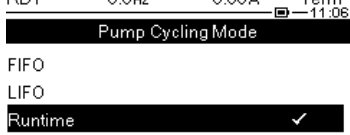
Step	Action
1	<p>Go to [Complete settings] <i>C 5 E</i> → [Pump functions] <i>P F E</i> → [Booster Control] <i>b 5 E</i> → [System architecture] <i>Π P 9</i> → [Pump Configuration] <i>P ∪ Π P</i> menu</p>    
2	<p>Set [Pump Cycling Mode] <i>Π P P C</i> to [Runtime] <i>r E , Π E</i></p> 

Part VII

Parameters Table

Introduction

The part shows all the parameters modified to allow configuration of the Booster Control Optimized application.

What is in This Part?

This part contains the following topics:

Parameters Table.....	58
-----------------------	----

Parameters Table

Parameters List Used in this Note

The following table shows all the parameters modified to allow configuration of the Booster Control Optimized application.

You can write the value for your application on the **Customer value** column.

You can use the SoMove *Altivar Process ATV600 : DTM* to store the configuration

Menu	Parameter	Application Note Setting	Customer value
[Simply start]	[Motor Standard] <i>b F r</i>	[50 Hz IEC] <i>5 D</i>	
	[Nominal Motor Power] <i>n P r</i>	5.50 kW	
	[Nom Motor Voltage] <i>u n 5</i>	400 Vac	
	[Nom Motor Current] <i>n C r</i>	11.20 A	
	[Nominal Motor Freq] <i>F r 5</i>	50.0 Hz	
	[Nominal Motor Speed] <i>n 5 P</i>	2,930 rpm	
	[Motor Th Current] <i>i t H</i>	11.20 A	
	[Acceleration] <i>A C C</i>	10.0 s	
	[Deceleration] <i>d E C</i>	10.0 s	
	[Low Speed] <i>L 5 P</i>	30.0 Hz	
	[High Speed] <i>H 5 P</i>	50.0 Hz	
[Macro Configuration]	[Application Selection] <i>A P P t</i>	[Pump Booster Control] <i>b o o 5 t</i>	
[Define system units]	[P sensor unit] <i>S u P r</i>	[0.01 Bar] <i>0 0 1 b A r</i>	
	[Flow rate unit] <i>S u F r</i>	[0.1 m3/h] <i>0 1 0 3 H</i>	
[Sensors Assignment]	[InletPres Assign] <i>P 5 1 A</i>	[AI1] <i>A , 1</i>	
	[AI1 Type] <i>A , 1 t</i>	[Current] <i>0 A</i>	
	[AI1 Min.Value] <i>C r L 1</i>	4.0 mA	
	[AI1 Max Value] <i>C r H 1</i>	20.0 mA	
	[AI1 Lowest Process] <i>A , 1 J</i>	-100	
	[AI1 Highest Process] <i>A , 1 K</i>	300	
	[OutletPres Assign] <i>P 5 2 A</i>	[AI2] <i>A , 2</i>	
	[AI2 Type] <i>A , 2 t</i>	[Current] <i>0 A</i>	
	[AI2 Min. Value] <i>C r L 2</i>	4.0 mA	
	[AI2 Max Value] <i>C r H 2</i>	20.0 mA	
	[AI2 Lowest Process] <i>A , 2 J</i>	0	
	[AI2 Highest Process] <i>A , 2 K</i>	1000	
	[Inst.Flow Assign.] <i>F 5 1 A</i>	[AI3] <i>A , 3</i>	
	[AI3 Type] <i>A , 3 t</i>	[Current] <i>0 A</i>	
	[AI3 Min. Value] <i>C r L 3</i>	4.0 mA	
	[AI3 Max Value] <i>C r H 3</i>	20.0 mA	
[AI3 Lowest Process] <i>A , 3 J</i>	0		
[AI3 Highest Process] <i>A , 3 K</i>	800		
[Eth Module Config]	[ETH Option IP Mode]	[Fixed] <i>0 0 0 0</i>	
	[IP address]	192.168.0.xx ⁽¹⁾	
	[Mask]	255.255.255.0	
[Pump characteristics]	[Mode] <i>P C 0</i>	[PHQ] <i>P H 9</i>	

Menu	Parameter	Application Note Setting	Customer value
	[Pump Speed] <i>P C S P</i>	2900 rpm ⁽²⁾	
	[Flow at BEP] <i>P C b q</i>	32.2 ⁽²⁾	
	[Head BEP] <i>P C b H</i>	3.82 ⁽²⁾	
	[Power BEP] <i>P C P b</i>	5.47 ⁽²⁾	
	[Flow 1] <i>P C q 1</i> ...[Flow 5] <i>P C q 5</i>	15.4 21.0 37.8 41.5 45.5 _ ⁽²⁾	
	[Head 1] <i>P C H 1</i> ...[Head 5] <i>P C H 5</i>	4.60 4.40 3.38 3.00 2.52 _ ⁽²⁾	
	[Power 1] <i>P C P 1</i> ...[Power 5] <i>P C P 5</i>	3.79 4.42 5.82 5.97 6.12 _ ⁽²⁾	
	[Pump Curve Activate] <i>P C A</i>	[Yes] <i>Y E S</i>	
[Booster Control]	[Pump System Archi] <i>Π P S A</i>	[Multi Drives] <i>n v S d</i>	
	[M/P Device Role] <i>Π P d t</i>	[Master] <i>Π A S t</i> , [Slave] <i>S L A V E</i> and [Slave] <i>S L A V E</i> ⁽¹⁾	
	[Nb of Devices] <i>Π P G n</i>	3	
	[M/P Device ID] <i>Π G i d</i>	1, 2 and 3- ⁽¹⁾	
	[MultiDrive ErrorResp] <i>Π d L b</i>	[Freewheel Stop] <i>n S t</i>	
	[MDL Comm Timeout] <i>Π L t o</i>	0.20 s	
	[M/P Device ErrorResp] <i>Π P d b</i>	[Freewheel Stop] <i>n S t</i>	
	[Pump Cycling Mode] <i>Π P P C</i>	[Runtime] <i>r t i P E</i>	
	[Type of control] <i>t o C t</i>	[PRESSURE] <i>P r E S S</i>	
	[M/P speed Mode] <i>Π P S t</i>	[Advanced] <i>A Π C</i>	
	[Boost S/D Condition] <i>b S d C</i>	[Energy Optimized] <i>o P t</i>	
	[Inst. Flow Assign.] <i>F S i A</i>	[AI3] <i>A i 3</i>	
	[Booster Stg Delay] <i>b S d</i>	5.0 s	
	[Booster Dstg Delay] <i>b d d</i>	5.0 s	
	[Booster S/D Flow Hyst] <i>b S d H</i>	3.0 %	
[PID Controller]	[Type of control] <i>t o C t</i>	[PRESSURE] <i>P r E S S</i>	
	[PID feedback] <i>P i F</i>	[AI2] <i>A i 2</i>	
	[Intern PID Ref] <i>P i i</i>	[No] <i>n o</i>	
	[Ref Freq 1 Config] <i>F r i</i>	[Ref.Freq-Rmt.Term] <i>L C C</i>	
	[Min PID Process] <i>P i P i</i>	0.00 bar	

Menu	Parameter	Application Note Setting	Customer value
	[Max PID Process] P , P 2	10.00 bar	
<p>NOTE: ⁽¹⁾ : Depend on the drive : Master or Slaves. ⁽²⁾ : Depend on your pump curves</p>			

