

Canalis KT

Busbar Trunking System

Installation Manual

QGH3492101-04
12/2025

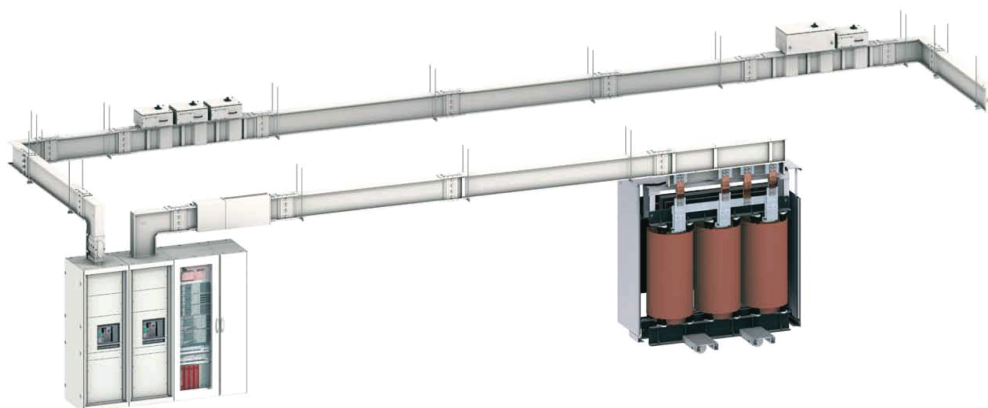

Legal Information

The information provided in this document contains general descriptions, technical characteristics and/or recommendations related to products/solutions.

This document is not intended as a substitute for a detailed study or operational and site-specific development or schematic plan. It is not to be used for determining suitability or reliability of the products/solutions for specific user applications. It is the duty of any such user to perform or have any professional expert of its choice (integrator, specifier or the like) perform the appropriate and comprehensive risk analysis, evaluation and testing of the products/solutions with respect to the relevant specific application or use thereof.

The Schneider Electric brand and any trademarks of Schneider Electric SE and its subsidiaries referred to in this document are the property of Schneider Electric SE or its subsidiaries. All other brands may be trademarks of their respective owner.

This document and its content are protected under applicable copyright laws and provided for informative use only. No part of this document may be reproduced or transmitted in any form or by any means (electronic, mechanical, photocopying, recording, or otherwise), for any purpose, without the prior written permission of Schneider Electric.

Schneider Electric does not grant any right or license for commercial use of the document or its content, except for a non-exclusive and personal license to consult it on an "as is" basis.

Schneider Electric reserves the right to make changes or updates with respect to or in the content of this document or the format thereof, at any time without notice.

To the extent permitted by applicable law, no responsibility or liability is assumed by Schneider Electric and its subsidiaries for any errors or omissions in the informational content of this document, as well as any non-intended use or misuse of the content thereof.

Table of Contents

Safety Information.....	4
Essential Safety Instructions	5
About the Document.....	6
Preparation and Organization	7
Equipment and Tools	8
Reception and Handling	10
Layout, Missing Links, and Pre-Installation Checks	13
Phase Order Check	14
Run Component Dimensions	17
Minimum Distances from Walls and Ceilings	18
Electrical Safety Instructions.....	19
Installation of Supports and Run Components	20
General Rules for Installing Supports	21
Installation of Horizontal Runs	25
Installation of Horizontal Run Components on Supports	27
Installation of Joint Blocks	30
Installation of Vertical Runs	33
Transformer Connections	36
Connection to Oil-Immersed Transformers	37
Connection to Dry-Type Transformers	40
Connection to Trihal Dry-Type Transformers	43
Switchboard Connections.....	46
Connection to Switchboards	47
Connection to PrismaSeT P and Okken Switchboards.....	51
Installation of Tap-Off Units	54
Installation of Plug-In Tap-Off Units	55
Installation of Bolted Tap-Off Units	60
Installation of Specific Components.....	62
Installation of Expansion Units	63
Installation of Fire-Barrier Kit	67
Commissioning and Maintenance	70
Commissioning	71
Commissioning Check-list Before Energizing	74
Maintenance	76
List of Instruction Sheets.....	78

Safety Information

Important Information

Read these instructions carefully, and look at the equipment to become familiar with the device before trying to install, operate, service, or maintain it. The following special messages may appear throughout this documentation or on the equipment to warn of potential hazards or to call attention to information that clarifies or simplifies a procedure.





The addition of this symbol to a “Danger” or “Warning” safety label indicates that an electrical hazard exists which will result in personal injury if the instructions are not followed.



This is the safety alert symbol. It is used to alert you to potential personal injury hazards. Obey all safety messages that follow this symbol to avoid possible injury or death.

 DANGER
DANGER indicates a hazardous situation which, if not avoided, will result in death or serious injury.

 WARNING
WARNING indicates a hazardous situation which, if not avoided, could result in death or serious injury.

 CAUTION
CAUTION indicates a hazardous situation which, if not avoided, could result in minor or moderate injury.

NOTICE
NOTICE is used to address practices not related to physical injury.

Please Note

Electrical equipment should be installed, operated, serviced, and maintained only by qualified personnel. No responsibility is assumed by Schneider Electric for any consequences arising out of the use of this material.

A qualified person is one who has skills and knowledge related to the construction and operation of electrical equipment and its installation, and has received safety training to recognize and avoid the hazards involved.

Essential Safety Instructions

⚠ WARNING

HAZARD OF CRUSHING AND FRACTURES

- Wear Personal Protective Equipment (PPE) when handling and installing the products (long sleeved jacket, trousers, gloves, safety shoes, helmet, and safety glasses).
- Only personnel who have been trained in safety regulations may work on construction sites to install busbar trunking system.
- Work with extreme caution and follow the instructions provided in the manual.

Failure to follow these instructions can result in death, serious injury, or equipment damage.



About the Document

Document Scope

This manual provides the preliminary requirements and detailed installation procedures for Canalis KT busbar trunking system. Additionally, it provide the recommendations for commissioning and maintenance of the system.

This manual is intended for trained personnel.

Validity Note

This manual is valid for Canalis KT busbar trunking system.

The characteristics of the products described in this document are intended to match the characteristics that are available on www.se.com. As part of our corporate strategy for constant improvement, we may revise the content over time to enhance clarity and accuracy. If you see a difference between the characteristics in this document and the characteristics on www.se.com, consider www.se.com to contain the latest information.

Environmental Data

For product compliance and environmental information, refer to the Schneider Electric Environmental Data Program.

Related Documents

Title of Documentation	Reference Number
Canalis KTA Catalog	DEBU021EN
Canalis KTC Catalog	DEBU024EN

To find documents online, visit the Schneider Electric download center (www.se.com/ww/en/download/).

Instruction Sheets

The list of instruction sheets for the installation of the Canalis KT busbar trunking system are listed in the List of Instruction Sheets, page 78.

Information on Non-Inclusive or Insensitive Terminology

As a responsible, inclusive company, Schneider Electric is constantly updating its communications and products that contain non-inclusive or insensitive terminology. However, despite these efforts, our content may still contain terms that are deemed inappropriate by some customers.

Preparation and Organization

What's in This Part



Equipment and Tools	8
Reception and Handling	10
Layout, Missing Links, and Pre-Installation Checks	13
Phase Order Check	14
Run Component Dimensions.....	17
Minimum Distances from Walls and Ceilings.....	18
Electrical Safety Instructions	19

Equipment and Tools

Introduction



The following table lists the necessary tools, equipment, and supplies for the installation of the Canalis KT busbar trunking system.

Equipment for Lifting and Handling

	<p>Crane or forklift truck with minimum fork length of 2 m and capable of lifting 1.5 tons or higher.</p>		<p>Two slings for handling the components.</p>
---	---	--	--

NOTE: The lifting and handling equipment required can vary, depending on the configuration of the site.

Equipment for Positioning and Installing Supports

	<p>Drilling machine capable of drilling through concrete.</p>		<p>Set of flat or ring spanners (10...22 mm).</p>
	<p>Socket wrench with sockets (10...22 mm).</p>		<p>Set of screwdrivers.</p>
	<p>Carpenters square.</p>		<p>Measuring tape (metric).</p>
	<p>Insulation tester (megohmmeter (1000 Vdc)).</p>		<p>Leveling instrument (spirit level).</p>
	<p>Torque wrench with the sockets of 10...22 mm (10...100 N•m).</p>		<p>Leveling instrument (line laser).</p>

Reception and Handling

Introduction

The Canalis KT system includes the following components:

- Run components including straight lengths, elbows, zed units, and tees
- Joint blocks
- Expansion units
- Tap-off units
- Supports
- Feed units for transformers and switchboards
- Sealing kits
- Protective covers for transformers
- Cable boxes
- Coupling isolators
- Connection accessories

Scope of Delivery

All materials are packaged and sent with a delivery note, a packing list, and short installation instructions.

Receiving the Materials

Follow these instructions after the materials are received:

- Note the information symbols and labels on the packaging. Pay attention to safety labels.
- Verify that the documentation and materials correspond to your installation project.
- Verify that the material is in proper condition and without transport or water damage.
- Verify that all the materials ordered are supplied and they function as indicated in the documentation.

NOTE: Claims for defective or damaged materials in the shipment must be made in writing to Schneider Electric within 30 days of receiving the shipment. Schneider Electric is not responsible for repair or replacement if the claim is not made within 30 days of receiving the shipment.

Proper Handling of Materials

NOTICE

HAZARD OF BREAKAGE

- Proceed with caution and pay attention to personnel safety. Use necessary equipment for correct handling.
- Do not damage the metal housing on the run components.
- Do not use abrasive or metal slings for lifting the run components.
- Do not use steel cables or hooks for lifting the run components.
- Do not use the ends of the run components for lifting.
- Do not drag the run components on the ground.

Failure to follow these instructions can result in equipment damage.

Handle the Canalis KT components carefully to prevent damage to their internal parts, external appearance, and the conductors at the ends of the run components.

Follow these instructions when handling the Canalis KT components:

- Do not subject the components to twist, dent, impact, and other forms of rough handling.
- Ensure that the handling equipment at the installation site is adequate for handling the components.
- Verify the lifting capacity of the crane or other available equipment.
- Use nylon straps to distribute the weight of the components when hoisting with a crane.
- Position the component on the fork to distribute the weight properly when using a forklift.
- Insert spreaders to avoid damage to the components when using cables.

Unpacking

Unpack the Canalis KT components carefully to prevent damage to the components. Follow these instructions for correct unpacking:

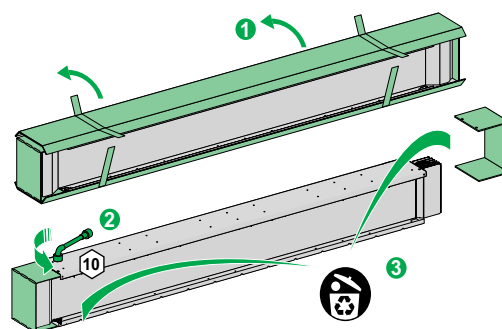

1. Use nail pullers to unpack and band cutters to cut the bands that secure the packaging.
2. Use correct tools to remove the reinforced protective cover packing at the end of the run components.
3. Discard the packaging.

Storage

NOTICE

HAZARD OF EQUIPMENT DAMAGE

Do not store the Canalis KT components outdoors. The components are weather resistant.

Failure to follow these instructions can result in equipment damage.

If the Canalis KT components are not installed immediately, store the components as per the following instructions to avoid damage:

- Store the components in their original packing in a clean and dry area with a constant temperature.
- If you must store components outdoors, cover the components securely to protect against harsh environments.

Provide temporary electrical heating under the cover to prevent condensation and ensure the proper temperature and even heat distribution under the cover.

Layout, Missing Links, and Pre-Installation Checks

Layout

Before installation, compare the plan received from the design office (or Schneider Electric), with the actual layout of the building.

Specific points about the layout:

- Ensure that the floors, the walls, and the ceilings where supports are to be positioned are strong enough to handle the weight. The floors, the walls, and the ceilings must be made of metal or concrete.
- Ensure that no other equipment obstruct the run. For example, HVAC, plumbing, and so on.

Identifying the Locations of Missing Links

Missing links are gaps in sections of straight lengths of run components. They are sometimes introduced to ease the installation process and to optimize the system according to on-site constraints. Be aware of these missing links and their locations on-site.

For long runs, it is often difficult to plan the dimensions of the missing links. In these cases, the run components to fill the missing links are ordered at the end of the installation after the gaps to be filled are measured.

Pre-Installation Check

It is recommended to perform an insulation test on the run components before installation to check for damage or contamination during shipment or storage.

When the rated operating voltage $U_e < 500 \text{ Vac}$, perform an insulation test on each run component as follows:

- Using a megohmmeter of 500 Vdc or higher (DC to avoid inductive and capacitive currents), make measurements between active conductors and exposed conductive parts (phase-to-phase, phase-to-neutral, phase-to-ground, and neutral-to-ground).
- The test is satisfactory if the insulation resistance between active conductors and exposed conductive parts is minimum $1000 \Omega/\text{V}$ per circuit, referred to the supply voltage to ground of these circuits.

NOTE: When the rated operating voltage $U_e > 500 \text{ Vac}$, perform the test at 1000 Vdc. The insulation resistance must be 1 M Ω or higher.

Phase Order Check

Checking the Phase Order

⚡⚠ DANGER

HAZARD OF ELECTRIC SHOCK

Incorrect phase order can result in short circuit.

Failure to follow these instructions will result in death or serious injury.

Perform the following phase order checks:

- Check the phase order of the layout and the existing connected equipment. For example, transformers and switchboards.
- Check the phase order of the run components before installation. This is important for the correct installation of the run, as the Canalis KT run components are asymmetric. Check the phase order by:
 - Locating and aligning the neutral conductor.
 - Checking the labels on the run components.
- Check if the Reinforced Protective Earth (PER) is being used.
- Check the phase orders of end feed units.

Locating and Aligning the Neutral Conductor

To find the rules for locating and aligning the neutral conductor, refer to AAV32038 instruction sheet.

The position of the neutral conductor is indicated by a slot located on the opposite side of the run component to the neutral conductor.

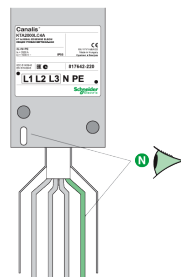

Ensure the alignment of the neutral conductors by checking that the slots are aligned on the same side.

Correct alignment.

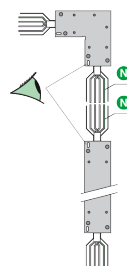

Incorrect alignment.

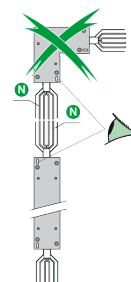

NOTE: The mismatch protection of Canalis KT system does not allow the assembly of two run components, if the neutral conductors are not on the same side.

Checking the Labels on the Run Components

The labels on the run components provide information about the phase order, polarity, and dimensions.

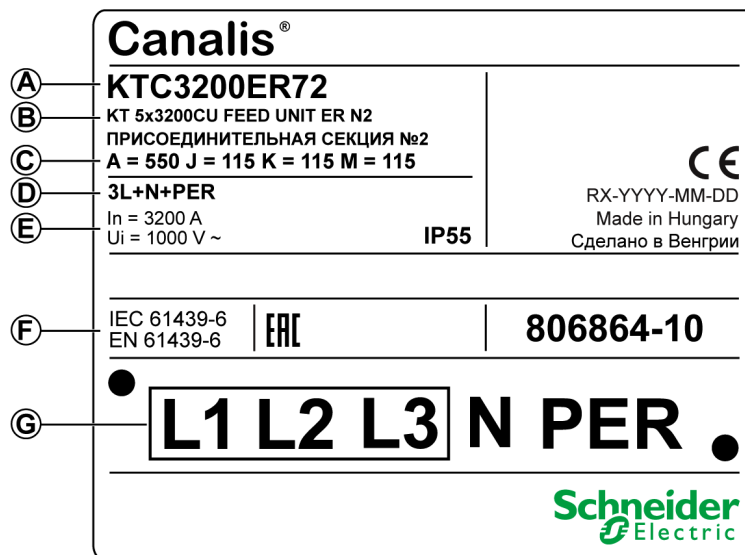

- A Commercial reference
- B Product description
- C Product dimensions
- D Polarity
- E Product rating
- F Standard specifications (IEC/EN)
- G Phase order

Checking for Changes in the Phase Order Using the Labels on the Run Components

The standard phase order N321 is displayed on the label as L1 L2 L3 N.

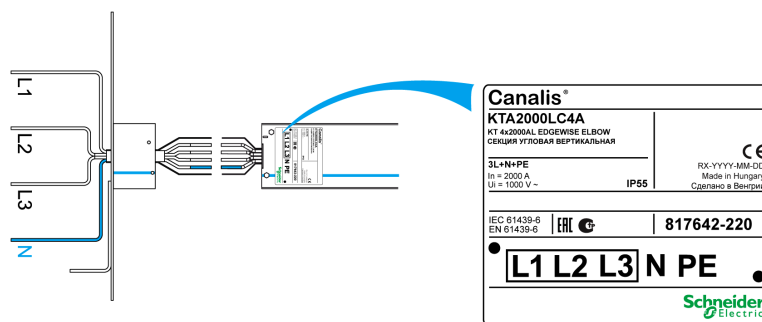

If the standard phase order is changed to N123, a changed label showing L3 L2 L1 N must be stuck over the phase order indication on the run component label, as displayed in the following graphic. The changed label is supplied with each joint block.

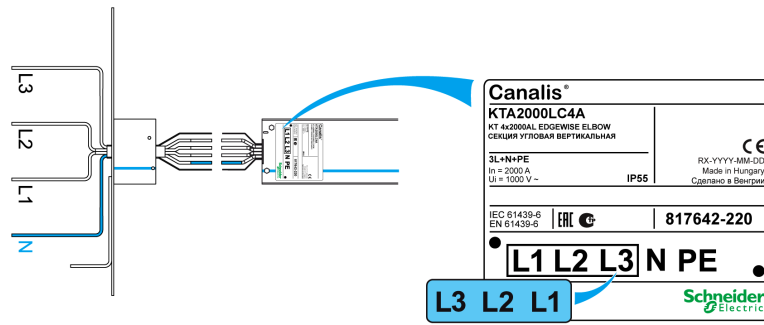

Reinforced Protective Earth

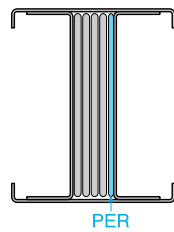

The Reinforced Protective Earth (PER) conductor version of the busbar trunking system, 3L + N + PER, is fitted with an additional internal conductor with a cross-section equal to half that of the phase conductor. Check the alignment of this conductor between run conductors during installation. The reinforced conductor has an additional 3 mm on the PER conductor and is located on the same side as the neutral conductor.

For information about the installation of PER in a PrismaSeT P or Okken switchboard, refer to Connection to PrismaSeT P and Okken Switchboards, page 51.

Checking the Phase Order of the End Feed Units

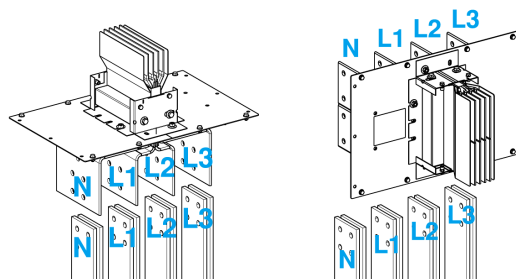

During installation, compare the phase order of any transformer or switchboard that is fed by an end feed unit, with the phase order of the end feed unit. This is necessary to enable the proper alignment of the conductors before making connections.

Run Component Dimensions

Introduction

The dimensions of the different run components, straight lengths, flat elbows, edgewise elbows, flat zed units, and edgewise zed units, are indicated on the labels.

Dimensions of Straight Lengths - Edgewise and Flatwise

The length (L) of a straight length is the distance in millimeters between the vertical axes located on either side of the run component. The vertical axis is located 20 mm from the end of the conductor. The length is mentioned on the label.

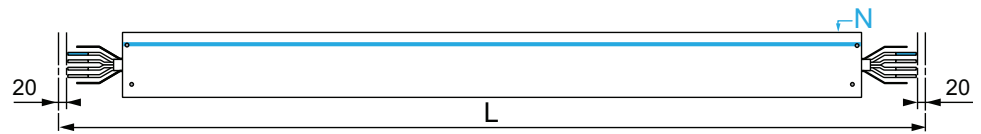

Dimensions of Direction-Changing Run Components

For flat and edgewise elbows, the dimensions are defined by the values of A and B. For flat and edgewise zed units, the dimensions are defined by the values of A, B, and C. The values are mentioned on the label.

Flat elbow

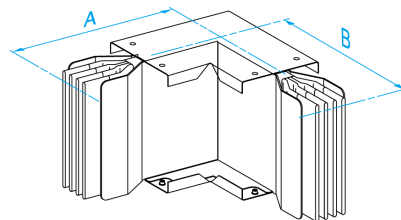

Edgewise elbow

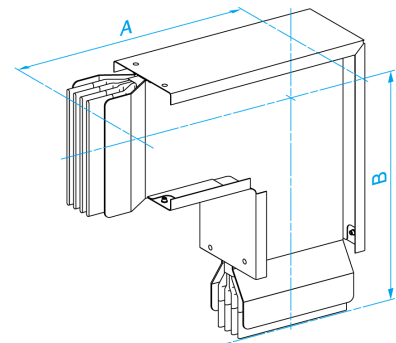

Flat zed unit

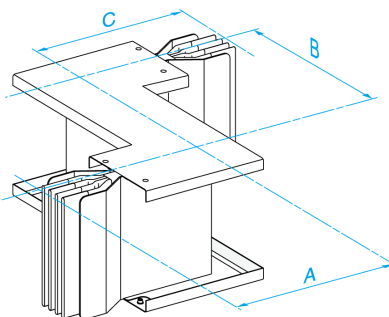

Edgewise zed unit

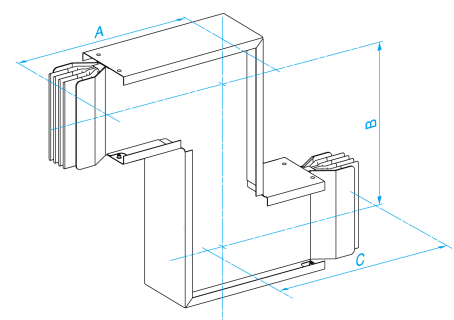

Minimum Distances from Walls and Ceilings

Edgewise Installation

Follow these rules for maintaining recommended minimum distances from walls and ceilings in edgewise installations of the run components:

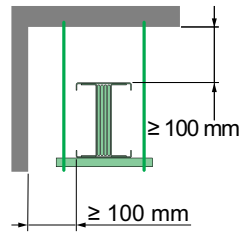

For run components installed edgewise:

- Maintain a minimum clearance distance of 100 mm from the top of the run components to the ceiling.
- Maintain a minimum clearance distance of 100 mm from the side of the run components to the wall.

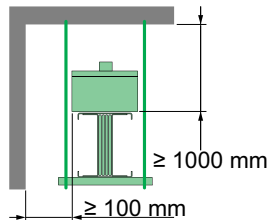

For run components installed edgewise with a tap-off unit, maintain a minimum clearance distance of 1000 mm from the top of the run components to the ceiling.

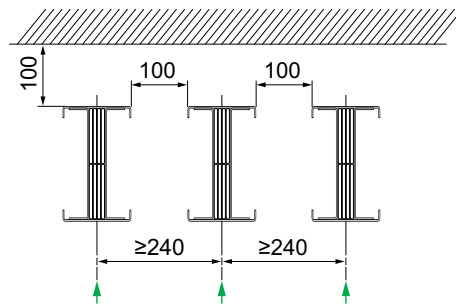

For multiple runs of Canalis KT run components:

- Maintain a minimum distance of 240 mm between the centers of the run components.
- Maintain a minimum distance of 100 mm between the run component ducts.
- Maintain a minimum distance of 100 mm between the ceiling and the run component ducts.

Green arrows indicate the direction of fitting the joint blocks.

NOTE: The minimum distances are necessary to enable the correct installation of the joint block.

Flatwise Installation

Follow these rules for maintaining recommended minimum distances from walls and ceilings in flatwise installations of the run components:

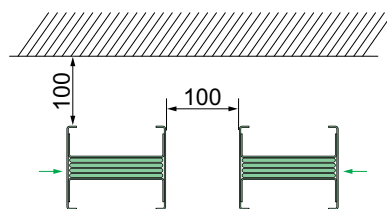

For run components installed flatwise:

- Maintain a minimum clearance distance of 100 mm from the top of the run components to the ceiling.
- Maintain a minimum clearance distance of 100 mm between the run components.

Green arrows indicate the direction of fitting the joint blocks.

NOTE: The minimum distances are necessary to enable the correct installation of the joint block.

Electrical Safety Instructions

Introduction

During the installation, commissioning, and maintenance of the Canalis KT busbar trunking system, it is very important to observe general electrical safety instructions. These instructions apply to all the installation, connection, commissioning, and maintenance procedures described in this manual.

Precautions

Read and understand the following precautions before performing any procedures in this guide.

DANGER

HAZARD OF ELECTRIC SHOCK, EXPLOSION, OR ARC FLASH

- Apply appropriate Personal Protective Equipment (PPE) and follow safe electrical work practices per NFPA 70E, NOM-029-STPS, or CSA Z462 or local equivalent.
- This equipment must only be installed, operated, serviced, or maintained by qualified electrical maintenance personnel.
- Before working on or inside this equipment, ensure that all power supplying the equipment is switched off.
- Use only the specified voltage when operating this equipment and any associated products.
- Always use a properly rated voltage sensing device to confirm power is off.
- Use appropriate interlocks where personnel and/or equipment hazards exist.
- Power line circuits must be wired and protected in compliance with local and national regulatory requirements.

Failure to follow these instructions will result in death or serious injury.

Installation of Supports and Run Components

What's in This Part

General Rules for Installing Supports	21
Installation of Horizontal Runs	25
Installation of Horizontal Run Components on Supports	27
Installation of Joint Blocks	30
Installation of Vertical Runs	33

General Rules for Installing Supports

Safety Instructions

⚠ CAUTION
<p>HAZARD OF IMPROPER INSTALLATION</p> <ul style="list-style-type: none"> • Study and understand the layout plan before installing the supports. • Consider the recommended separation distance between the supports during installation. • Ensure that the supports are leveled, so that the run components are level after installation. • Ensure that the supports are able to bear the weight of the run components. <p>Failure to follow these instructions can result in injury or equipment damage.</p>

Introduction

Install the supports properly to ensure the proper installation of the Canalis KT run components. Follow these general rules when installing supports for the Canalis KT run components.

General Rules

Follow these general rules for installing supports:

- Do not leave any run component must unsupported.
- For easier leveling, use minimum two supports for each run component wherever possible.
- The supports must have a supporting capacity of equal to or greater than the weight of the run component plus an additional 90 kg, in accordance with IEC 61439-6 standard.
- Provide the separate supports for the components at the terminal ends of the run. The weight of end components must not be carried by transformers or switchboards.
- Position the supports for the vertical branches as near as possible to the elbow angle.
- Provide individual supports for the elbows and zed units.
- Install the supports near to joint blocks. However, a support must never be positioned directly under a joint block.

Edgewise horizontal installation

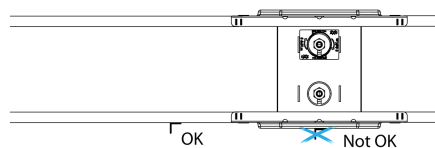

Flatwise horizontal installation

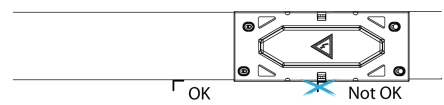

Supports for Edgewise Installation

For edgewise installations, the maximum recommended distance between supports is 3000 mm. In all cases, two supports must be provided for 4000 mm sections.

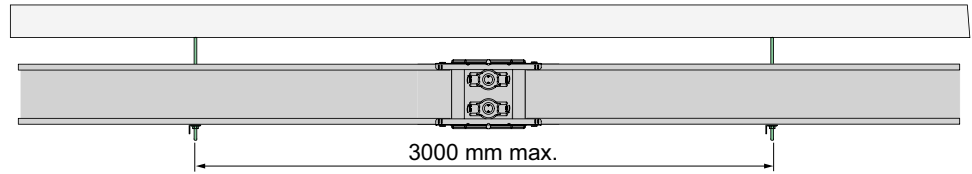

Supports for Flatwise Installation

For flatwise installations, the maximum recommended distance between supports is 2000 mm. In addition, a support must be placed at a maximum distance of 400 mm from the joint block axis.

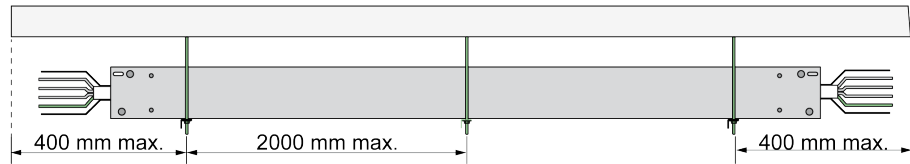

Supports for LC Elbows

LC elbows (height 244...404 mm) must have a support installed across the elbow angle.

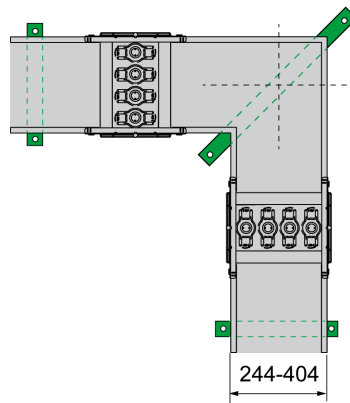

Supports for TC Tees

TC tees (height 324...404 mm) must have a support installed across the T-joint.

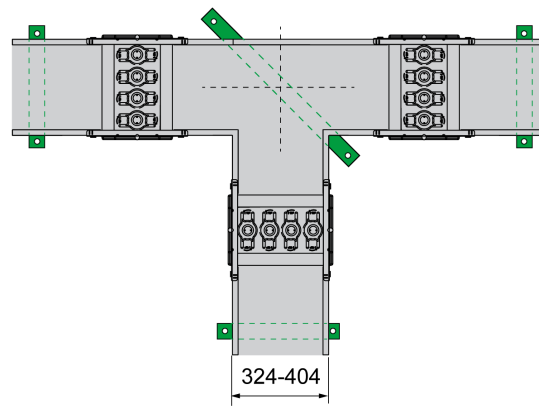

Supports for LC Edgewise Elbows With a Vertical Branch

Follow these rules to support LC edgewise elbows with a vertical branch:

- LC elbows must be supported from the top if the distance between the angle and the center of the nearest joint block is less than 350 mm.

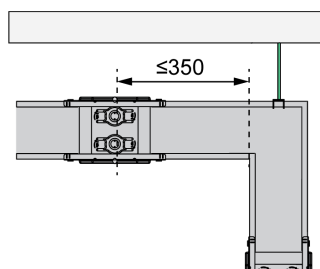

- LC elbows must be supported from the bottom if the distance between the angle and the center of the nearest joint block is greater than 350 mm.

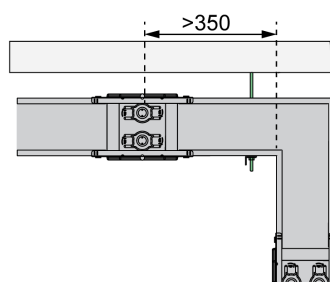

Supports for LP Flatwise Elbows With a Vertical Branch

LP flatwise elbows with a vertical branch must be supported close to the angles.

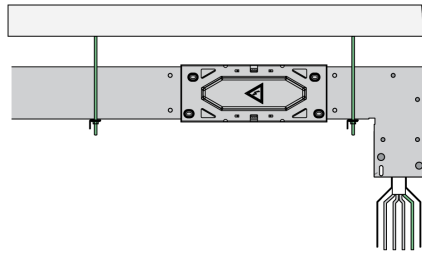

Installation of Horizontal Runs

Introduction

Follow these stages to install a horizontal run:

1. Install the support. For more information, refer to Horizontal Supports, page 25.
2. Install the run components on the supports. For more information, refer to Installation of Horizontal Run Components on Supports, page 27.
3. Install the joint blocks. For more information, refer to Installation of Joint Blocks, page 30.

Horizontal Supports

Horizontal supports enable the run components to be installed horizontally and adjusted along the length. They also help absorb any movement of the run components. Horizontal supports can be installed on the ceiling or the wall.

Before installing the horizontal supports, refer to the General Rules for Installing Supports, page 21.

Types of Horizontal Supports

The following table lists the type of horizontal supports:

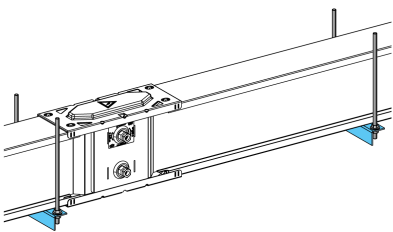
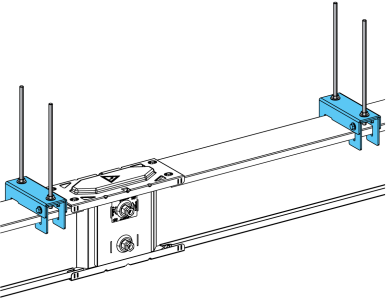
Horizontal support	Characteristics	Catalog number
	<ul style="list-style-type: none"> • Attached to the ceiling using 2 x 2 m threaded M10 rods (provided by Schneider Electric). • Provide support for edgewise run components from the bottom. 	<p>KTB0000ZA1</p>
	<ul style="list-style-type: none"> • Attached to the ceiling using rods (not provided by Schneider Electric). • Provide support for edgewise run components from the top. • Installation instructions are available in the instruction sheet, AAV32042, which is available on the Schneider Electric website. 	<p>KTB0074ZA4 KTB0404ZA4</p>

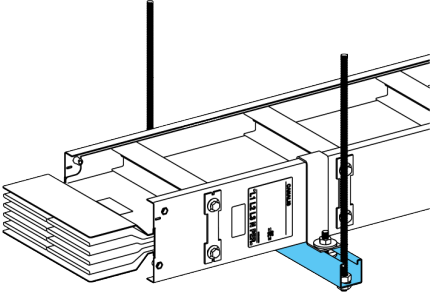
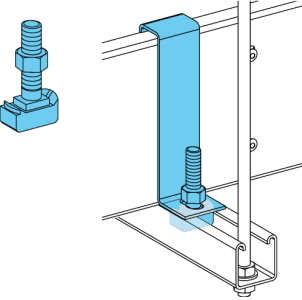
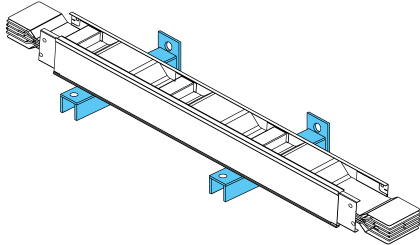
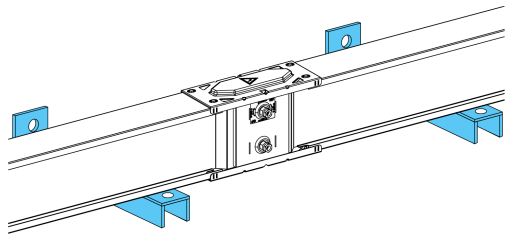
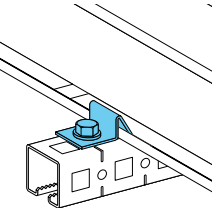
Horizontal support	Characteristics	Catalog number
	<ul style="list-style-type: none"> Attached to the ceiling using 2-m rods supplied with the support. Provide support for flatwise run components from the bottom. 	<p>KTB****ZA7</p>
	<ul style="list-style-type: none"> KTB0000ZA8 brackets are attached to KTB****ZA7 supports with KTB0000YB6 T-bolts for flatwise horizontal installation. Supports must be installed without blocking linear expansion of the busbar trunking. 	<p>KTB0000ZA8 KTB0000YB6</p>
	<ul style="list-style-type: none"> Attached to the wall. Provide support for flatwise run components from the bottom. Supports not provided by Schneider Electric. 	<p>–</p>
	<ul style="list-style-type: none"> Attached to the wall. Provide support for edgewise run components from the bottom. Supports not provided by Schneider Electric. 	<p>–</p>
	<ul style="list-style-type: none"> Hooks attached to the support for edgewise horizontal installation. Keep the busbar trunking in place on its support, without blocking it, in order to allow expansion movements. 	<p>KTB0000ZA3</p>

Installation of Horizontal Run Components on Supports

Introduction

After installing the supports, install the run components.

Procedure

The procedure for installing the run components is described in the following relevant instruction sheets:

- For Canalis KTA1000-4000/KTC1350-5000 run components, refer to the AAV32038 instruction sheet.
 - For Canalis KTA5000/KTC6300 run components, refer to the PHA33884 instruction sheet.
1. Ensure that the installed supports are at the correct minimum distances from the walls and the ceilings, refer to *Minimum Distances from Walls and Ceilings*, page 18.
 2. Ensure that the supports for horizontal runs are installed correctly, refer to *General Rules for Installing Supports*, page 21.
 3. Verify the phase order and position of the neutral conductors of all the run components, refer to *Phase Order Check*, page 14.
 4. Install the horizontal run components on the supports.
 5. Adjust the gaps due to the asymmetric profiles in KT•••ED•• and KT•••EH•• components, refer to *Installing Run Components for Tap-Off Units*, page 28.
 6. Adjust the distance between the ends of the run components using the spacer positioned between the closest conductors. A hardwood material spacer must be 40 ± 2 mm, as it is necessary for installing the joint block⁽¹⁾.

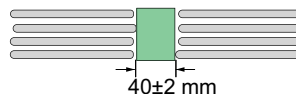

7. Check the alignment of the run components with a 1 m long leveling instrument. Refer to *Aligning the Run Components*, page 29.
8. Install the joint block, refer to *Installation of Joint Blocks*, page 30.

(1) At the junction, joint block has the poke yoke design to help ensure the active conductors are well placed.

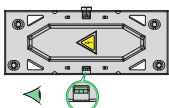

Installing Run Components for Tap-Off Units

NOTICE

HAZARD OF EQUIPMENT DAMAGE

Take special care when positioning the supports under run components designed for tap-off units, when the run components are installed flatwise:

- Do not position the supports in front of outlets or future tap-off units.
- Add spacers between supports and run components to compensate for the asymmetry of their lateral profiles due to the extra size of the tap-off unit outlets.

Failure to follow these instructions can result in equipment damage.

For KT•••EB•• run components, install the supports under the sheet metal enclosure. No spacers are required.

For KT•••ED and KT•••EH•• run components, install the spacers on supports to compensate for the gap, so that the base of the component is parallel to the supports.

The gap to be compensated depends on:

- If the run component is installed with the neutral at the top or at the bottom.
- If the support is installed under the upper hood profile of the tap-off unit outlet (A) or the sheet metal enclosure (B).

For KT•••ED•• run components

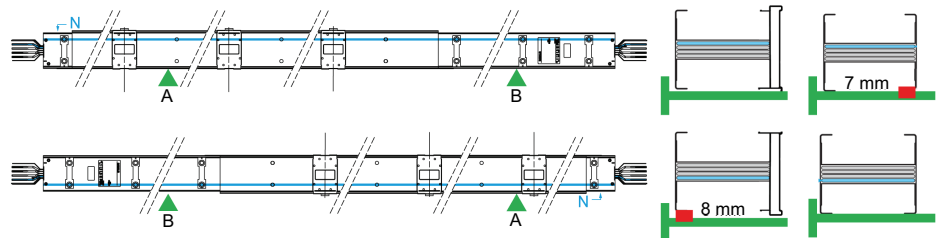

KT•••EH•• run components

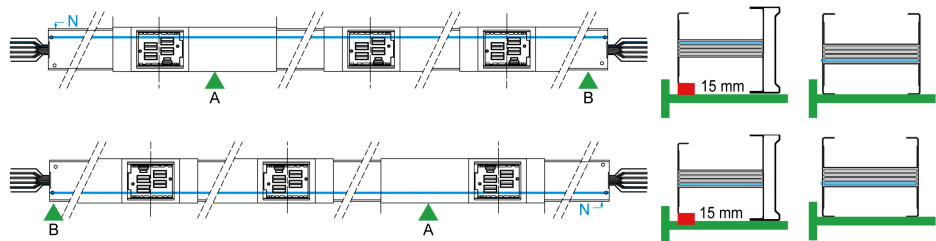

- Spacers
- ▲ Example of position of supports
- A** Support under upper hood profile of the tap-off unit outlet
- B** Support under sheet metal enclosure
- Position of neutral conductor

Aligning the Run Components

NOTICE

LOSS OF IP55 PROTECTION RATING

Align the run components properly.

Failure to follow these instructions can result in equipment damage.

Ensure the proper alignment on both sides of the run components:

- Verify alignment on the top of the run components.

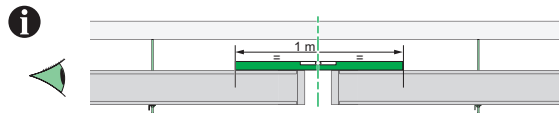

- Verify alignment on the side of the run components.



NOTE: Use line laser or spirit level for leveling.

- Verify alignment at the junction between the metallic side and the gasket is correct as per the IP55 protection rating.

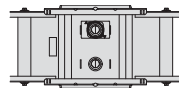

Installing KTA5000 or KTC6300 Run Components

KTA5000 run components are made of two KTA2500 run components. KTC6300 run components are made of two KTC3200 run components. The two run components are linked together and they can be installed flatwise or edgewise.

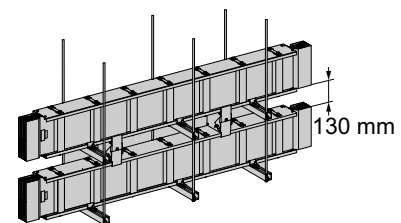
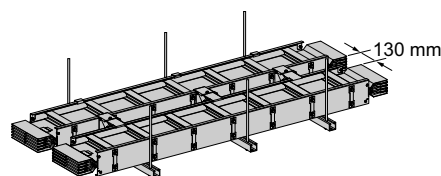

Refer to the PHA33884 instruction sheet for the installation of Canalis KTA5000 or KTC6300 run component.

Installation of Joint Blocks

Introduction

After installing the two run components on the horizontal and vertical supports and aligned, install the joint block.

The joint block provides the following:

- Electrical junction between live conductors and between PE protective earth conductors.
- Mechanical link between two run components or sections. It provides simultaneous continuity between all the conductors.

Procedure

1. Install the bottom cover under the aligned conductors of the two run components. Hand tighten the fixing screws.
2. Insert the joint block carefully between the two run components.
3. Check the alignment of the run components, joint blocks, and PE conductors. For more information, refer to *Checking the Alignment of the PE Protective Earth Conductors*, page 30.
4. Check the alignment of the joint block and the gaskets of the top and bottom covers to conform to the IP55 protection rating. For more information, refer to *Checking the Alignment of the Joint Block and Covers*, page 31.
5. Tighten the four fixing screws of the bottom cover to a torque of 10 N•m.
6. Install the top cover.
7. Tighten the four fixing screws of the top cover to a torque of 10 N•m.
8. Tighten the bolts of the joint block to a torque of 60 N•m, to provide the electrical connection. For more information, refer to *Rules for Tightening the Bolts of the Joint Block*, page 32.

For more information on installation of the joint block, refer to the AAV32038 instruction sheet.

Checking the Alignment of the PE Protective Earth Conductors

DANGER

HAZARD OF SHORT CIRCUIT

- Ensure that the run components, joint blocks, and PE conductors are properly aligned.
- Ensure that the run component conductors and the metallic side of the PE conductor are positioned properly between the fishplates.

Failure to follow these instructions will result in death or serious injury.

The continuity of the PE conductors is established by the enclosure of the run component. Ensure the correct position of the components, joint blocks, and PE conductors and the continuity of the PE conductors through the joint block.

Correct

Incorrect

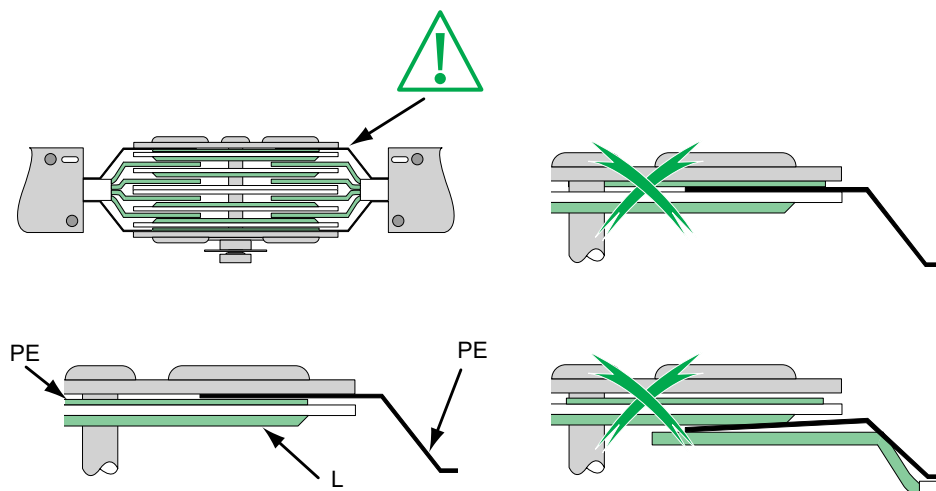

PE Protective earth conductor
L Fishplate

Checking the Alignment of the Joint Block and Covers

NOTICE

LOSS OF IP55 PROTECTION RATING

Ensure that the joint block and the gaskets of the top and bottom covers are properly aligned for the system to conform to IP55 protection rating standards.

Failure to follow these instructions can result in equipment damage.

Ensure the proper alignment on both the joint block and the cover:

- Verify the alignment of the joint block:

Correct

Incorrect

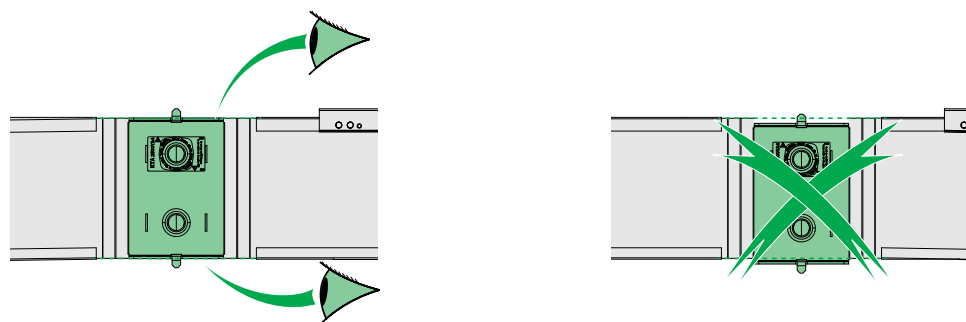

- Verify the alignment of the cover gaskets:

Correct

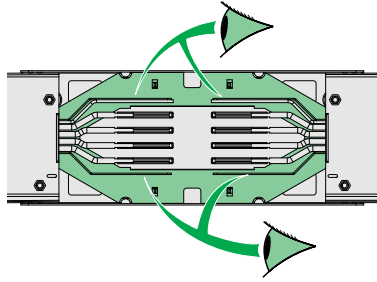

Incorrect

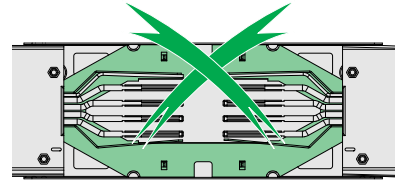

Rules for Tightening the Bolts of the Joint Block

Correct tightening of the bolts of the joint block enables the electrical connection through the run. Follow these rules when tightening the bolts:

- Tighten the connection bolts to a torque of 60 N•m.

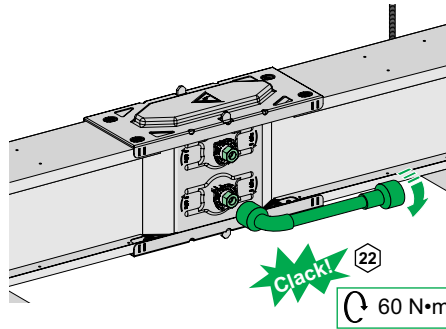

- Upon reaching the correct tightening torque, the nut head snaps off, releasing a red washer (shear nuts), which then falls off.

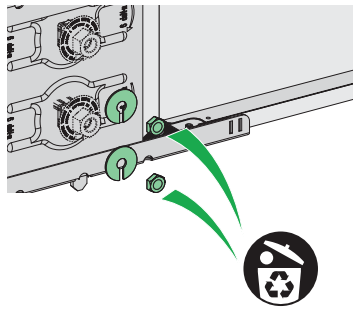

- The correct tightening is done only if the red washer is absent after the procedure.
- For dismantling or maintenance operations, the nut has a second head. If the joint block is dismantled and reassembled at installation or for maintenance, ensure the torque of 60 N•m with a torque wrench.

Installation of Vertical Runs

Introduction

Vertical supports enable the run components to be installed vertically and adjusted along the length. The spring helps the run component to remain attached to the wall bracket in case of expansion.

Vertical run component installations must always be made from bottom to top.

Vertical supports can be installed:

- On a wall, by using the KTB•••ZA52 wall brackets or customized wall brackets.

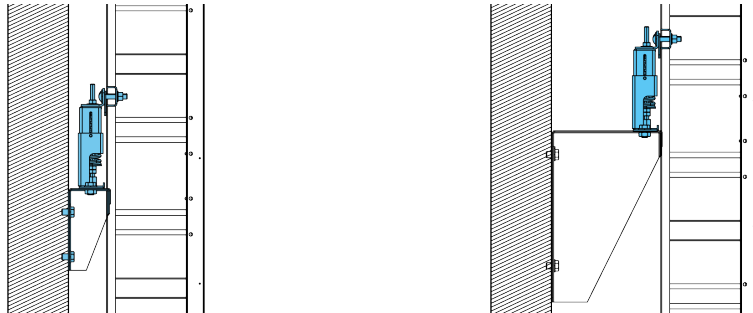

- On the floor, without any additional accessory.

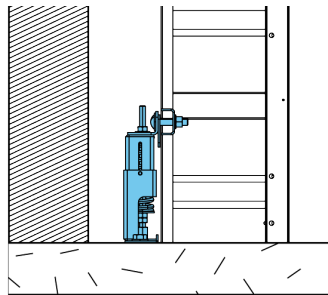

Types of Vertical Supports

There are two types of vertical supports. The type of support required depends on the rating of the busbar trunking system:

- A rear-wall fixing system, with one support attached to the run component and two brackets attached to the wall.

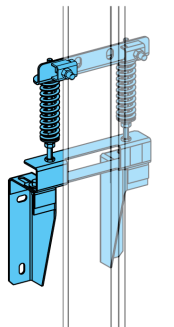

- A side-wall fixing system, with two supports attached to the run component and two brackets attached to the wall.

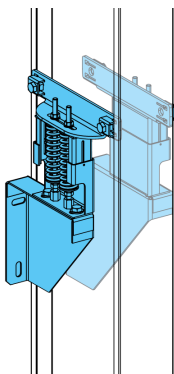

Ratings for Vertical Supports

The following table lists the ratings for vertical supports and wall brackets:

Ratings		Fixing type	Catalog number	
KTA	KTC		Vertical support	Wall brackets
800 to 1600	1000 to 2000	Rear	KTB0164ZA51	KTB0164ZA52
2000	2500	Side	KTB0204ZA51	KTB0204ZA52
2500	3200	Side	KTB0244ZA51	KTB0244ZA52
3200	4000	Side	KTB0324ZA51	KTB0324ZA52
4000	5000	Side	KTB0404ZA51	KTB0404ZA52
5000	6300	Side	2xKTB0244ZA51	Not provided by Schneider Electric.

Procedure

The procedure for installing vertical supports and the run components is described in the following relevant instruction sheets:

- For Canalis KT rear-wall fixing system, refer to the PHA12613 instruction sheet.
 - For Canalis KT side-wall fixing system, refer to the PHA12664 instruction sheet.
1. Before installing the vertical supports, refer to the General Rules for Installing Supports, page 21.
 2. Verify that the adjacent run component directly under the one being installed is properly in place.
 3. Set the spring compression value on the support.
The value of the spring compression depends on the rating of the run component.
 4. Attach the support to the run component by tightening the bolts to the correct torque.
 5. Ensure that the width of the support is at right angles to the length of the run component.
 6. Use the template delivered with the support to drill the holes for mounting the wall brackets on the wall.
 7. Mount the wall brackets on the wall.

8. Install the support of the run component on the wall bracket.
9. Attach the support using the supplied screws.
10. Check the distance between the end of the run component and the one directly below using the spacer positioned between the closest conductors. This spacer (hardwood material recommended) must be 40 ± 2 mm, which is equal to the required space for installing the joint block. Adjust the position of the support attached to the run component, if necessary.

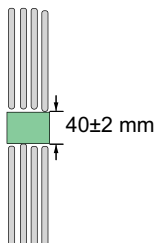

11. Align the run components with a 1 m long leveling instrument (spirit level or line laser). Refer to *Aligning the Run Components*, page 29.
12. Remove the nuts on the springs in the support that is fixed on the run component.
13. Install the joint block. Refer to *Installation of Joint Blocks*, page 30.

Installing KTA5000 or KTC6300 Run Components

KTA5000 run components are made of two KTA2500 run components. KTC6300 run components are made of two KTC3200 run components. Two KTB•••ZA51 vertical supports must be installed on each run component.

The vertical supports are installed on a wall bracket are not provided by Schneider Electric. They are linked together and can be installed flatwise or edgewise.

For more information on the installation of Canalis KTA5000 or KTC6300 run components with side by side vertical support, refer to the PHA33884 and PHA12664 instruction sheets.

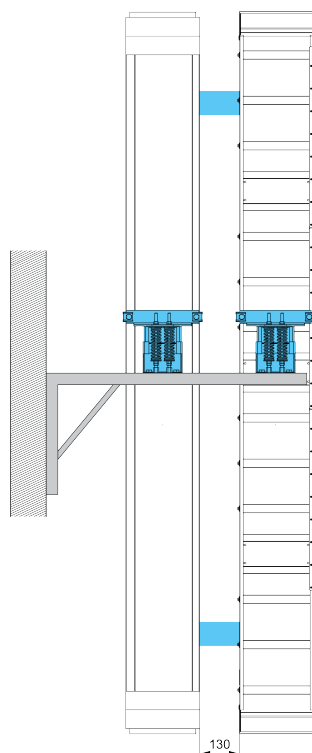

Transformer Connections

What's in This Part

Connection to Oil-Immersed Transformers	37
Connection to Dry-Type Transformers.....	40
Connection to Trihal Dry-Type Transformers.....	43

Connection to Oil-Immersed Transformers

Introduction

The Canalis KT system can be connected to oil-immersed transformers using either a vertical incomer arrangement or a horizontal incomer arrangement.

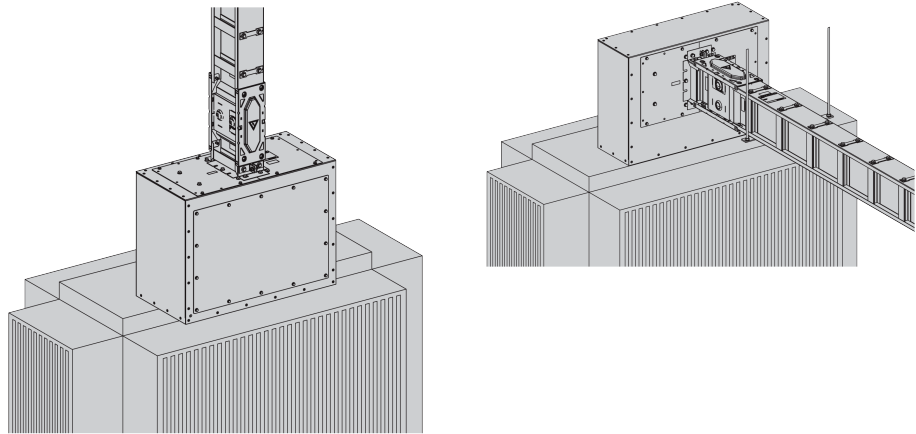

A KTB•••CR• protective cover must be installed on the transformer. If the transformer is delivered with a cable box, the cable box must be removed before the installation of the protective cover.

Procedure

The procedure for connecting oil-immersed transformers is described in the following instruction sheets:

- For connecting Canalis KTA1000-4000 or KTC1350-5000 to oil-immersed transformers, refer to the AAV17625 instruction sheet.
- For Canalis KTA1000-4000 or KTC1350-5000 vertical incomer arrangement, refer to the PHA12477 instruction sheet.
- For Canalis KTA1000-4000 or KTC1350-5000 horizontal incomer arrangement, refer to the PHA12478 instruction sheet.
- For Canalis KTA5000 or KTC6300 horizontal incomer arrangement, refer to the PHA44577 instruction sheet.
- For Canalis KTA5000 or KTC6300 vertical incomer arrangement, refer to the PHA44578 instruction sheet.

1. Remove the cable box if the transformer is equipped with a cable box.
2. Install the KTB•••CR• protective cover on the transformer.
3. Install the end feed unit with its supports.

The weight of the components must not rest on the transformer, refer to General Rules for Installing Supports, page 21.

4. Check the phase order of the run components in the installation, end feed units, and transformer, refer to Phase Order Check, page 14.
5. Open the protective cover.
6. Attach the end feed unit to the protective cover on the transformer.

NOTE: If the protective earth conductor (PE) must be connected to neutral conductor (N) to create a PEN, use the PEN link delivered with the end feed unit, refer to PEN Connection, page 38.

7. Connect the flexible links to the end feed unit and tighten the bolts to a torque of 60 N•m.

The number of flexible links required depends on the rating. For more information, refer to [Flexible Links](#), page 39.

8. Attach the flexible links to the transformer bars using one of the following methods:
 - With KTB0000YS• bar clamps, tightened to a torque of 100 N•m.
 - With bolts, tightened to the torque recommended by the manufacturer of the bolts.
9. Check for correct clearances between the flexible links, and between the bar clamps and the base of the transformer bars.
10. Close the protective cover of the transformer.

PEN Connection

To connect the protective earth conductor (PE) to the neutral conductor (N) to create a PEN, use the PEN link delivered with the end feed unit.

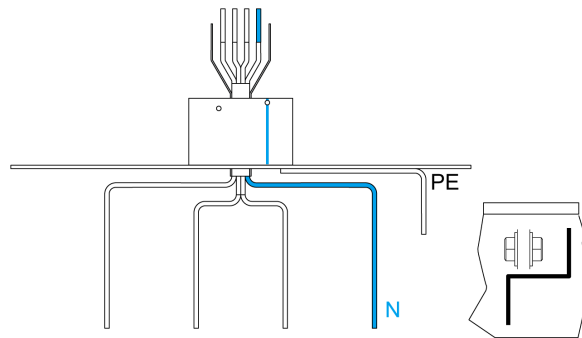

Connect the PEN link between the protective earth conductor (PE) and the neutral conductor (N) of the end feed unit by using the bolts delivered with the link.

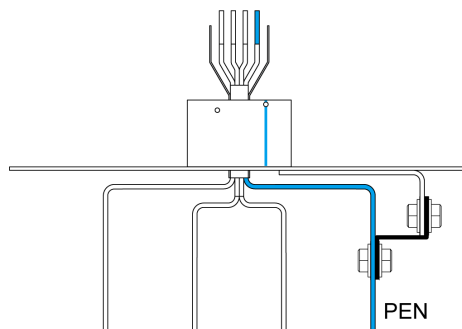

Flexible Links

The number of flexible links required for the connection of the transformer to the end feed unit depends on the rating of the busbar trunking system.

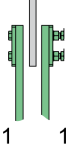
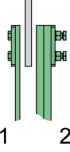
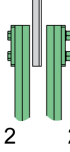
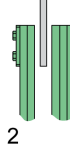
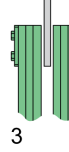
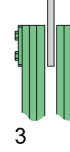
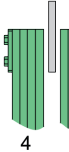
KTA rating (A)	1000 to 1600	2000 to 2500	3200	4000	-	5000	-
KTC rating (A)	1350 to 1600	2000 to 2500	3200	4000	5000	-	6300
Number of flexible links	 1 1	 1 2	 2 2	 2 3	 3 3	 3 3	 4 4
Copper Bars	2 (100×5)	3 (100×5)	4 (100×5)	5 (100×5)	6 (100×5)	6 (120×5)	8 (120×5)
Cross section (mm ²)	1000	1500	2000	2500	3000	3600	4800

Connection to Dry-Type Transformers

Introduction

The Canalis KT system can be connected to dry-type transformers in an edgewise or a flatwise arrangement. The incoming run component can be connected from the side or the center.

Examples of connection arrangements:

Edgewise with side incoimer

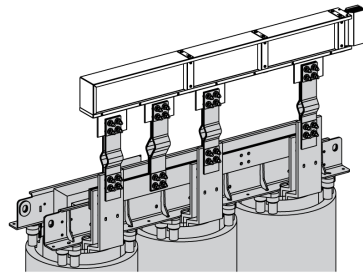

Flatwise with side incoimer

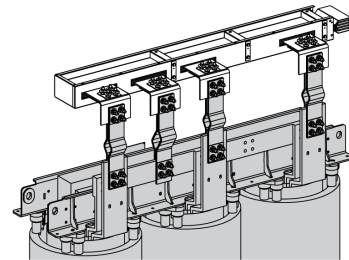

Edgewise with center incoimer

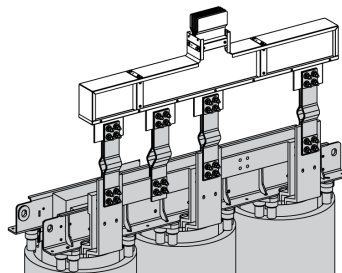

Flatwise with center incoimer

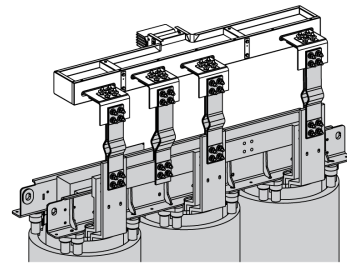

Edgewise with side incoimer for Canalis KTA5000/KTC6300

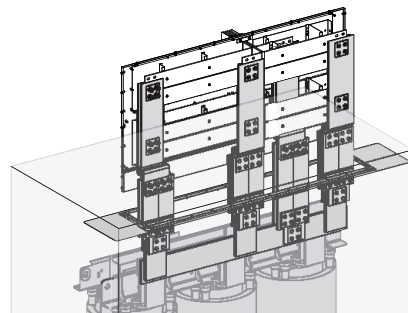

Flatwise with side incoimer for Canalis KTA5000/KTC6300

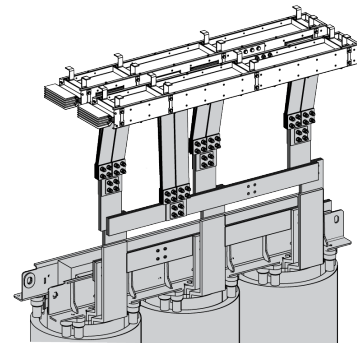

NOTE: Dry-type transformers can be connected to Canalis KTA5000 and KTC6300 only flatwise with side incoimer arrangement or edgewise with center incoimer arrangement.

Procedure

The procedure for connecting dry-type transformers is described in the following instruction sheets:

- For connecting Canalis KTA1000-4000 or KTC1350-5000 to dry-type transformers, refer to the AAV32054 instruction sheet.
 - For connecting Canalis KTA5000 or KTC6300 to dry-type transformers flatwise, refer to the PHA44575 instruction sheet.
 - For connecting Canalis KTA5000 or KTC6300 to dry-type transformers edgewise, refer to the PHA44576 instruction sheet.
1. Install the end feed unit with its supports, refer to Support of the End Feed Unit, page 41.
 2. Ensure that the weight of the components does not rest on the transformer, refer to General Rules for Installing Supports, page 21.
 3. Check the phase order of the run components in the installation, end feed unit, and transformer, refer to Checking the Phase Order, page 14.
 4. For transformers installed in an enclosure, make a cut-out on the top plate of the enclosure for the installation of a KTB••••CR• protective cover.
 5. If the installation is flatwise, attach the KTB••••YE• angle brackets on the end feed unit.
 6. Ensure that the distance from the conductors of the end feed units to the transformer bars is correct.

The number of flexible links depends on the rating. For more information, refer to Support of the End Feed Unit, page 41.

7. Attach the flexible links to the end feed unit and tighten the bolts to a torque of 60 N•m.
8. Attach the flexible links to the transformer with bolts and tighten the bolts to the torque recommended for the bolts used.
9. Check for correct clearances between the flexible links and between the bar clamps and the base of the transformer bar.
10. If the transformer is installed in an enclosure, install the KTB••••CR• protective cover in the cut-out made on the top plate of the enclosure.

Support of the End Feed Unit

If the end feed unit is installed in edgewise position, use KTB••••ZA4 supports (rods not provided). For more information, refer to the AAV32042 instruction sheet.

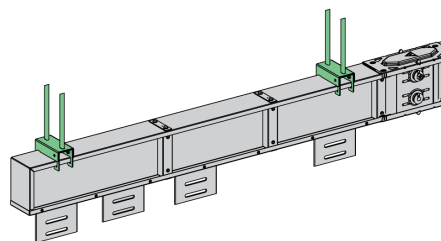

If the end feed unit is installed in flatwise position, use the KTB••••YE• brackets provided to attach M10 rods to the end feed unit (rods not provided).

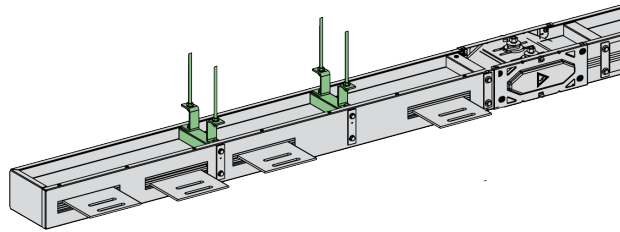

KTA rating (A)	800 to 1250	1600 to 2000	2500	3200 to 4000
KTC rating (A)	1000 to 1600	2000 to 2500	3200	4000 to 5000
Angle Bracket				
Reference number	KTB0000YE1	KTB0000YE21	KTB0000YE22	KTB0000YE23

Flexible Links

The number of flexible links required for the connection of the transformer to the end feed unit depends on the rating of the busbar trunking system.

KTA rating (A)	1000 to 1600	2000 to 2500	3200	4000	-	5000	-
KTC rating (A)	1350 to 1600	2000 to 2500	3200	4000	5000	-	6300
Number of flexible links	 1 1	 1 2	 2 2	 2 3	 3 3	 2X3 2X3	 2X4 2X4
Copper Bars	2 (100×5)	3 (100×5)	4 (100×5)	5 (100×5)	6 (100×5)	12 (100×5) ⁽¹⁾	16 (100×5) ⁽¹⁾
Cross section (mm ²)	1000	1500	2000	2500	3000	6000	8000
⁽¹⁾ <ul style="list-style-type: none"> • ELN1 and ELN2 feed units: 100 x 5 • ELN5 feed unit: 120 x 5 							

Connection to Trihal Dry-Type Transformers

Introduction

The Trihal dry-type transformer can be equipped with a Canalis interface that enables a direct connection to the run components.

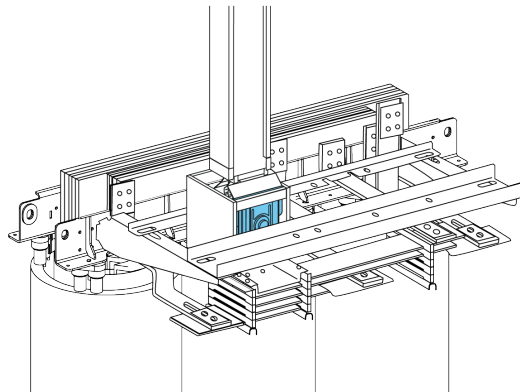

Procedure

The procedure for connecting a Trihal dry-type transformer is described on the transformer.

1. Check the supports and the run components. The weight of the components must not rest on the transformer, refer to [General Rules for Installing Supports](#), page 21.
2. Check the phase order and the neutral position between the run components and the transformer, refer to [Checking the Phase Order](#), page 14.
3. Cut out the top plate to prepare the installation of a KTB••••TT01 sealing kit if the transformer is installed in an enclosure, refer to [Sealing Kit for Transformers in an Enclosure](#), page 43.
4. Connect the run component to the Canalis interface. Run components of different heights can be used for one Trihal transformer rating [Connecting the Canalis Interface](#), page 44.
5. Tighten the bolts in the Canalis interface to a torque of 60 N•m.
NOTE: On Canalis interfaces of height 324 mm and 404 mm, there are four tightening bolts available. When connected to Canalis run components of height 164 mm, 204 mm, or 244 mm, the two external bolts need to be tightened to a torque of 10 N•m. In these cases the nut head remains on the bolt and the red washers must be removed manually.
6. Close the transformer with the sealing kit if the transformer is installed in an enclosure, refer to [Sealing Kit for Transformers in an Enclosure](#), page 43.

Sealing Kit for Transformers in an Enclosure

The top plate of the Trihal dry-type transformer in an enclosure must be cut out to enable the installation of a KTB••••TT01 sealing kit. The sealing kit includes a drilling and cut out template, illustrated here:

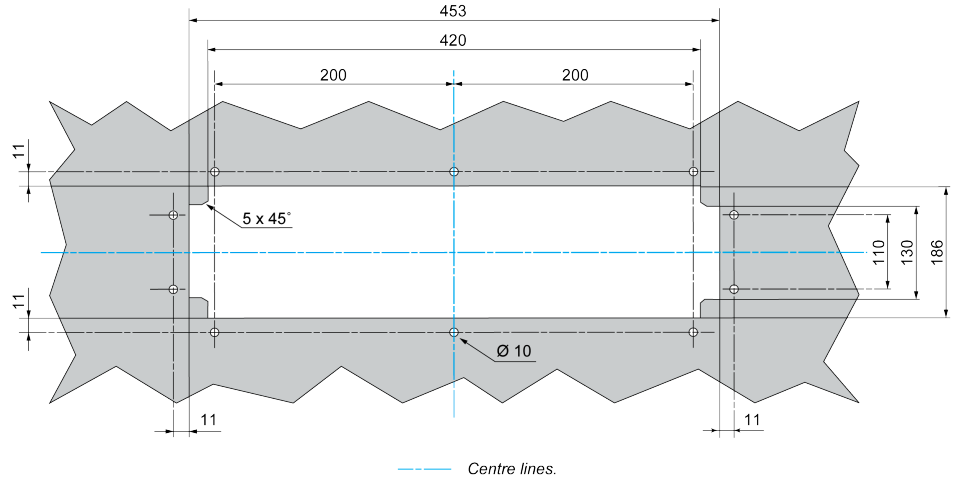

For more information on installation of the sealing kit, refer to the AAV32049 instruction sheet.

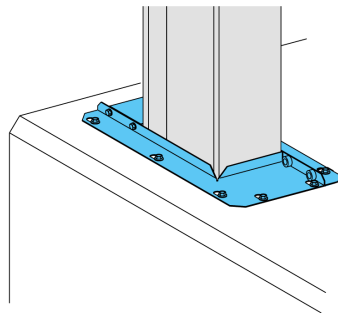

Connecting the Canalis Interface

The height of the Canalis interface is defined by the rating of the Trihal transformer.

The following graphic displays how the heights of the Canalis interface (J) and the run components (K) are defined.

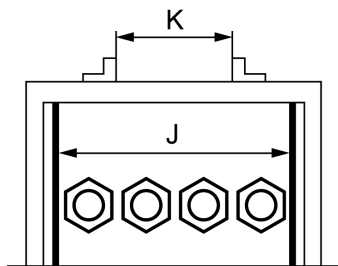

The following table lists the heights of the run components that can be connected to a Canalis interface of a given height:

Height of Canalis interface (J) in mm	Height of run component (K) in mm
124	74, 104, and 124
164	104, 124, and 164
204	204
244	204 and 244
324	244 and 324
404	324 and 404

Switchboard Connections

What's in This Part

Connection to Switchboards.....	47
Connection to PrismaSeT P and Okken Switchboards	51

Connection to Switchboards

Introduction

The Canalis KT system can be connected to switchboards:

- Directly to the connection bars.
- Using flexible links or connection bars, with a KTB••••CR• protective cover in a vertical or horizontal arrangement:

The following are examples of the connection arrangements:

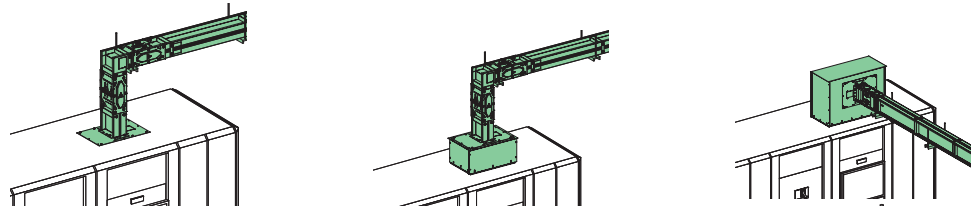

Procedure for Direct Connection

The procedure for direct connection to switchboards is described in the following instruction sheets:

- For connecting Canalis KTA1000-4000 or KTC1350-5000 to switchboard, refer to the AAV17625 instruction sheet.
- For Canalis KTA5000 or KTC6300 horizontal incomer arrangement, refer to the PHA44577 instruction sheet.
- For Canalis KTA5000 or KTC6300 vertical incomer arrangement, refer to the PHA44578 instruction sheet.

1. Ensure that the weight of the components does not rest on the switchboard, refer to *General Rules for Installing Supports*, page 21.
2. Check the phase order of the components in the installation, end feed unit, and switchboard, refer to *Phase Order Check*, page 14.
3. If the protective earth conductor (PE) must be connected to neutral conductor (N), create a PEN using the PEN link delivered with the end feed unit. For more information, refer to *PEN Connection*, page 48.
4. Cut out the top plate of the switchboard to enable the installation of the end feed unit flange.

5. Attach the end feed unit to the switchboard.

The number of connection bars depends on the rating, refer to *Flexible Links*, page 49.

6. Connect the end feed unit to the connection bars with bolts and tighten the bolts to a torque of 60 N•m.
7. Ensure that the enclosure of the end feed unit (PE or PER) is correctly connected to the earth of the switchboard.

8. Attach KTB0000YS1 bar supports on the flexible links or connection bars.

The number of KTB0000YS1 bar supports to be used depends on the length of the flexible links or connection bars. The distance between the KTB0000YS1 bar supports depends on the rated short-time withstand current I_{cw} of the equipment.

For more information, refer to *Distance Between Supports According to I_{cw}* , page 50.

9. Check for proper clearances between the active conductors and the switchboard.

Procedure for Connection Using a Protective Cover

The procedure for connection to switchboards using a KTB••••CR• protective cover is described in the AAV17625 instruction sheet.

1. Check that the weight of the components does not rest on the switchboard, refer to *General Rules for Installing Supports*, page 21.
2. Check the phase order of the components in the installation, end feed unit, and switchboard, refer to *Checking the Phase Order*, page 14.
3. If the protective earth conductor (PE) must be connected to neutral conductor (N), create a PEN using the PEN link delivered with the end feed unit.

For more information, refer to *PEN Connection*, page 48.

4. Cut out the top plate of the switchboard to enable the installation of the protective cover.
5. Install the protective cover on the switchboard.
6. Attach the end feed unit to the protective cover on the switchboard.
7. Open one panel of the protective cover.

The number of flexible links or connection bars depends on the rating, refer to *Flexible Links*, page 49.

8. Attach the flexible links or connection bars to the end feed unit and tighten the bolts to a torque of 60 N•m.
9. Attach the flexible links or connection bars to the switchboard bars with bolts and tighten the bolts to the torque recommended by the bolt manufacturer.
10. Attach KTB0000YS1 bar supports on the flexible links or connection bars.

The number of KTB0000YS1 bar supports to be used depends on the length of the flexible links or connection bars. The distance between the KTB0000YS1 bar supports depends on the rated short-time withstand current I_{cw} of the equipment.

For more information, refer to *Distance Between Supports According to I_{cw}* , page 50.

11. Check for proper clearances between the active conductors and the switchboard.
12. Close the protective cover.

PEN Connection

To connect the protective earth conductor (PE) to the neutral conductor (N), create a PEN using the PEN link delivered with the end feed unit.

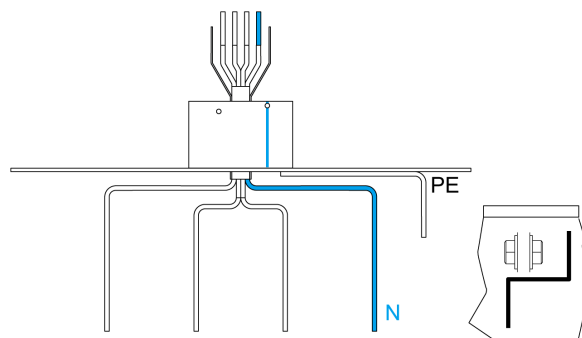

Connect the PEN link between the protective earth conductor (PE) and the neutral conductor (N) of the end feed unit by using the bolts delivered with the link.

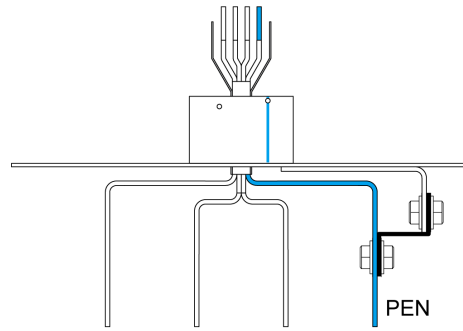

Flexible Links

The number of flexible links or connection bars required for the connection of the switchboard to the end feed unit depends on the rating of the busbar trunking system.

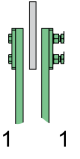
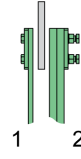
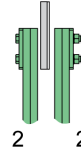
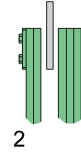
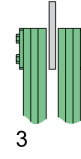
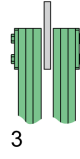
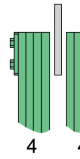
KTA rating (A)	1000 to 1600	2000 to 2500	3200	4000	–	5000	–
KTC rating (A)	1350 to 1600	2000 to 2500	3200	4000	5000	–	6300
Number of flexible links	 1 1	 1 2	 2 2	 2 3	 3 3	 3 3	 4 4
Copper Bars	2 (100×5)	3 (100×5)	4 (100×5)	5 (100×5)	6 (100×5)	6 (120×5)	8 (120×5)
Cross section (mm²)	1000	1500	2000	2500	3000	3600	4800

Distance Between Supports According to I_{cw}

Use the KTB0000YS1 bar supports to support the flexible links or connection bars. The number of bar supports depends on the length of the flexible links or connection bars and the value of I_{cw} .

The following table lists the maximum distance between two supports, depending on the I_{cw} , and enable you to calculate the number of supports needed for the length of flexible links or connection bars used:

Rated short-time withstand current I_{cw}	Maximum distance x between 2 supports
$I_{cw} \leq 43 \text{ kA}$	400 mm
$43 \text{ kA} < I_{cw} \leq 50 \text{ kA}$	225 mm
$50 \text{ kA} < I_{cw} \leq 100 \text{ kA}$	150 mm

Installation of bar supports

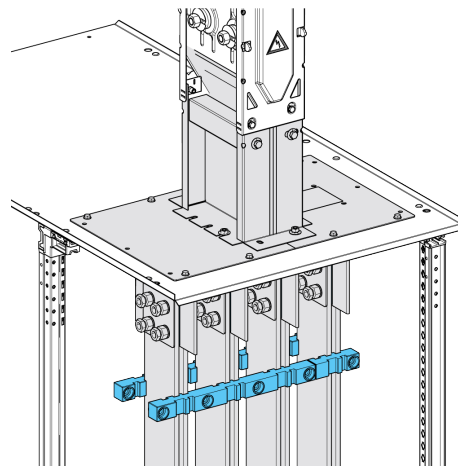

Maximum distance between bars supports (x)

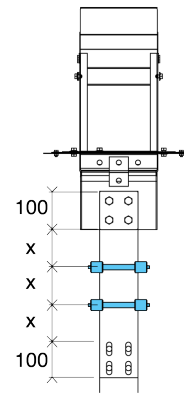

:

Connection to PrismaSeT P and Okken Switchboards

Introduction

The PrismaSeT P and Okken switchboards can be equipped with a Canalis interface that enables a direct connection between the main circuit breaker installed in the switchboard and the run components of the Canalis KT system.

PrismaSeT P switchboard

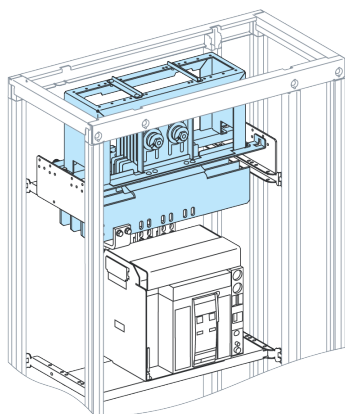

Okken switchboard

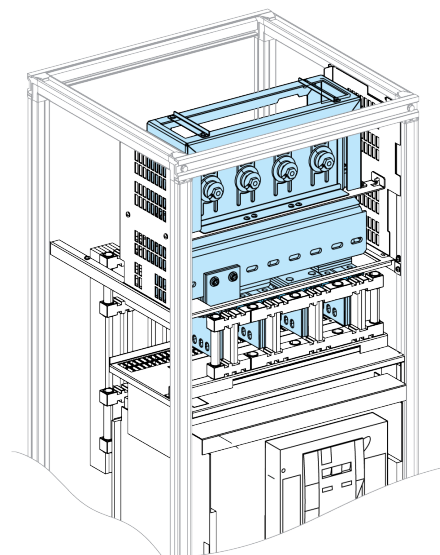

Procedure

1. Ensure that the weight of the components does not rest on the switchboard, refer to *General Rules for Installing Supports*, page 21.
2. Check the installation of the Canalis interface in the switchboard, refer to *Adapting the Canalis Interface*, page 53.
3. Check the phase order and the position of the neutral between the run component and the Canalis interface, refer to *Checking the Phase Order*, page 14.
4. If the run component is equipped with a reinforced protective earth conductor (PER), install a KTB•••PE1 reinforced protective earth conductor to the Canalis interface. For more information, refer to *Installing a Reinforced Protective Earth (PER) Conductor*, page 52.
5. Cut out the top plate of the switchboard to prepare the installation of a KTB•••TT01 sealing kit, refer to *Sealing Kit*, page 52.
6. Adapt the position of the guides on the Canalis interface to the rating of the run component, refer to *Adapting the Canalis Interface*, page 53.
7. Connect the run component to the Canalis interface. Tighten the bolts in the Canalis interface to the torque of 60 N•m.

NOTE: On Canalis interfaces of height 404 mm, there are four tightening bolts available. When connected to a Canalis run component of height 204 mm, the two external bolts need to be tightened to a torque of 10 N•m. In this case, the nut head remains on the bolt and the red washers must be removed manually.

8. Attach the sealing kit on the switchboard, refer to *Sealing Kit*, page 52.

Checking the Canalis Interface in the Switchboard

To check the correct installation of the Canalis interface in the switchboard, refer the following instruction sheets:

- For Canalis interface for MasterPact NT and ComPact NS in PrismaSeT P switchboard, refer to the 04696147 instruction sheet.
- For Canalis interface for MasterPact NW 800 to 3200 A in PrismaSeT P switchboard, refer to the 04696148 instruction sheet.
- For Canalis interface for MasterPact NW 4000 A in PrismaSeT P switchboard, refer to the 04696291 instruction sheet.

Installing a PER Conductor

The procedure for adding the PER to the Canalis interface is described in the S1A32783 instruction sheet.

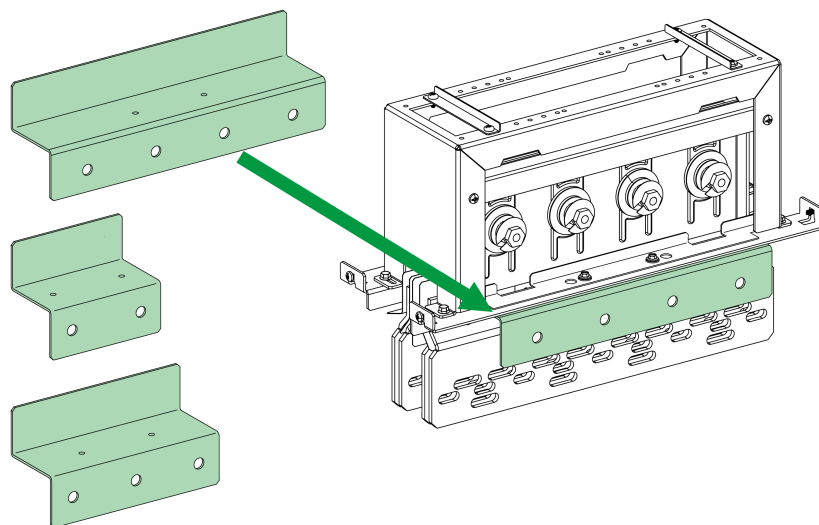

Sealing Kit

The top plate of the switchboard must be cut out to enable the installation of a KTB••••TT01 sealing kit. The sealing kit includes a drilling and cut out template, illustrated here:

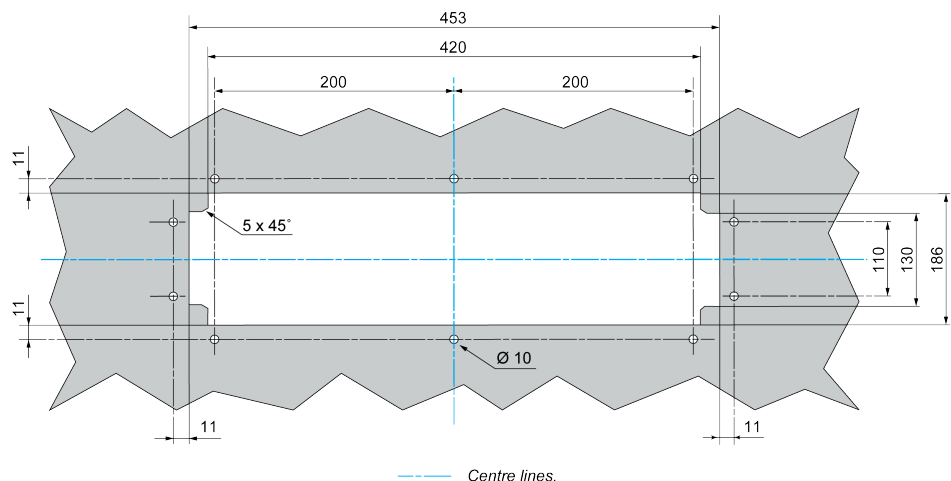

For more information on installation of the sealing kit, refer to the AAV32049 instruction sheet.

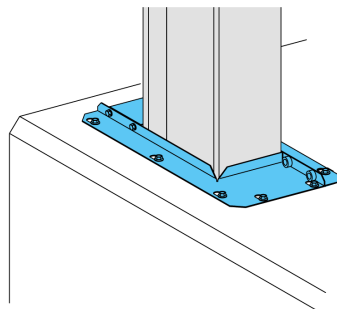

Adapting the Canalis Interface

The size of the Canalis interface is defined by the type of the main circuit breaker installed in the switchboard.

The following graphic displays how the heights of the Canalis interface (J) and the run components (K) are defined:

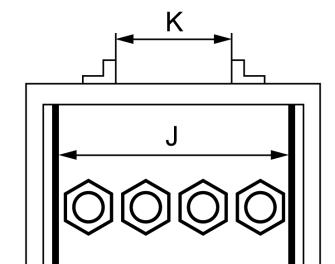

The following table lists the heights of the run components that can be connected to a Canalis interface of a given height:

Height of the Canalis interface (J) (mm)	Height of the run component (K) (mm)
164	74, 104, 124, and 164
244	164, 204, and 244
404	244, 324, and 404

The position of the guides on the Canalis interface must be adapted to the rating of the run component.

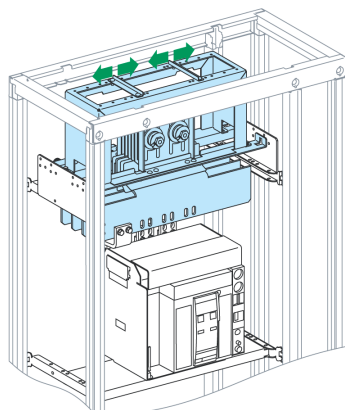

Installation of Tap-Off Units

What's in This Part

Installation of Plug-In Tap-Off Units	55
Installation of Bolted Tap-Off Units	60

Installation of Plug-In Tap-Off Units

Introduction

Tap-off units are used to connect loads or secondary runs. They comply with installation standards and regulations (IEC 60364) irrespective of the earthing system (TT, TNS, TNC, or IT).

The plug-in tap-off units can be operated and plugged in or unplugged when the Canalis KT system is live. Plugging in and unplugging a tap-off unit automatically opens and closes the tap-off point.

⚠️⚠️ DANGER

HAZARD OF ELECTRIC SHOCK, EXPLOSION, OR ARC FLASH

- Beware of potential hazards.
- Do not open or close the cover of a tap-off unit with the downstream load energized.
- Carefully inspect the work area for tools and objects that can be left inside the tap-off unit.

Failure to follow these instructions will result in death or serious injury.

Types of Plug-In Tap-Off Units

There are two types of plug-in tap-off units:

- Plug-in tap-off units without automatic clamping system.

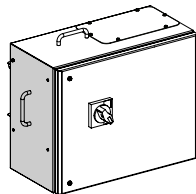

- Plug-in tap-off units with automatic clamping system.

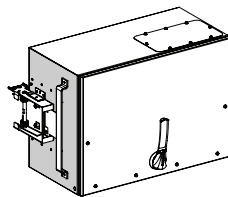

The plug-in tap-off units from the Canalis KS system are compatible with the Canalis KT system.

Installing Plug-In Tap-Off Units Without Automatic Clamping System

The procedure for installing plug-in tap-off units without automatic clamping system is described in the corresponding instruction sheets listed in the following table:

Device installed in plug in-tap-off unit without automatic clamping system	Tap-off unit rating	Catalog number	Instruction sheet
ComPacT NSX circuit breaker	160 A	KSB160DC•••	AAV16555
	250 A	KSB250DC•••	
	400 A	KSB400DC•••	
Isolator for blade-type fuses	160 A	KSB160SE•	AAV16543
	250 A	KSB250SE•	AAV16546
	400 A	KSB400SE•	

Procedure

To install plug-in tap-off units without automatic clamping system:

1. Open the tap-off unit cover.
2. Install the protection device in the tap-off unit.
3. Remove the IP protection on the outlet of the run component.
4. Prepare the output cable glands and connect the cables to the tap-off unit.
5. Check that the protection device is switched off and carefully inspect the tap-off unit for tools and objects that can be left inside the tap-off unit.
6. Position the rear of the tap-off unit on the run component.
7. Plug the tap-off unit into the run component.
8. Lock the tap-off unit on the run component using the locking handle located inside the tap-off unit, refer to *Locking the Tap-Off Unit on the Run Component*, page 57.
9. Secure the tap-off unit on the run component using the fixing mechanism.
10. Close the tap-off unit cover.

The system and the load are ready to be energized.

Installing Plug-In Tap-Off Units With Automatic Clamping System

The procedure for installing plug-in tap-off units with automatic clamping system is described in the corresponding instruction sheets listed in the following table:

Device installed in plug in-tap-off unit with automatic clamping system	Tap-off unit rating	Catalog number	Instruction sheet
ComPacT NSX circuit breaker	630 A	KTB0630DC•	NVE44417
Isolator for blade-type fuses	630 A	KTB0630SD•	NVE48158
Isolator for blade-type fuses, internal arc tested	630 A	KTB0630SE•	NVE47487

The following table lists the accessories and their corresponding instruction sheets:

Accessories	Catalog number	Instruction sheet
Kit of connection bars for KTB0630DC•	KTB0630ZA01	NVE46045
Kit of connection bars for KTB0630SD•	KTB0630ZA02	NVE46746
Extension rotary handle for KTB0630SD• and KTB0630SE•	KTB0630ZA03	NVE49438

Procedure

To install plug-in tap-off units with automatic clamping system:

1. Install the automatic clamping system and the rear pivots delivered with the tap-off unit on the run component.
2. Open the tap-off unit cover.
3. Install the protection device in the tap-off unit.

NOTE: In tap-off units with PEN, you can remove the connection between the neutral and earth, if needed.

4. Remove the IP protection on the outlet of the run component.
5. Prepare the output cable glands and connect the cables to the tap-off unit.
6. Check that the protection device is switched off and carefully inspect the tap-off unit for tools and objects that may have been left inside the tap-off unit.
7. Place the tap-off unit on the rear pivots and click it into the disconnected position on the clamping system, refer to *Installing the Tap-Off Unit With Automatic Clamping System on the Run Component*, page 58.
8. Unlock the clamping system by pulling the attached flap and push the tap-off unit in the run component. The tap-off unit is in the connected position, refer to *Positions of the Tap-Off Unit With Automatic Clamping System*, page 59.
9. Secure the tap-off unit onto the run component using bolts.
10. Lock the tap-off unit on the run component using the locking handle located inside the tap-off unit, refer to *Locking the Tap-Off Unit on the Run Component*, page 57.
11. Close the tap-off unit cover.

The system and the load are ready to be energized.

Locking the Tap-Off Unit on the Run Component

A handle located inside the plug-in tap-off unit enables the tap-off unit to be mechanically locked onto the run component.

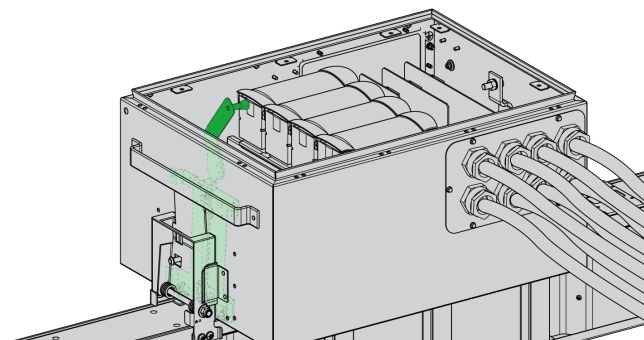

The locking handle is only accessible when the door of the tap-off unit is open. The door of the tap-off unit can only be opened when the protection device is off.

(no load). In this way, the tap-off unit cannot be removed from the run component when the load is on.

Installing the Tap-Off Unit With Automatic Clamping System on the Run Component

The tap-off unit with automatic clamping system is installed on the run component by placing the notches onto the rear pivots and rotating the tap-off unit down onto the run component. The tap-off unit clicks into the disconnected position.

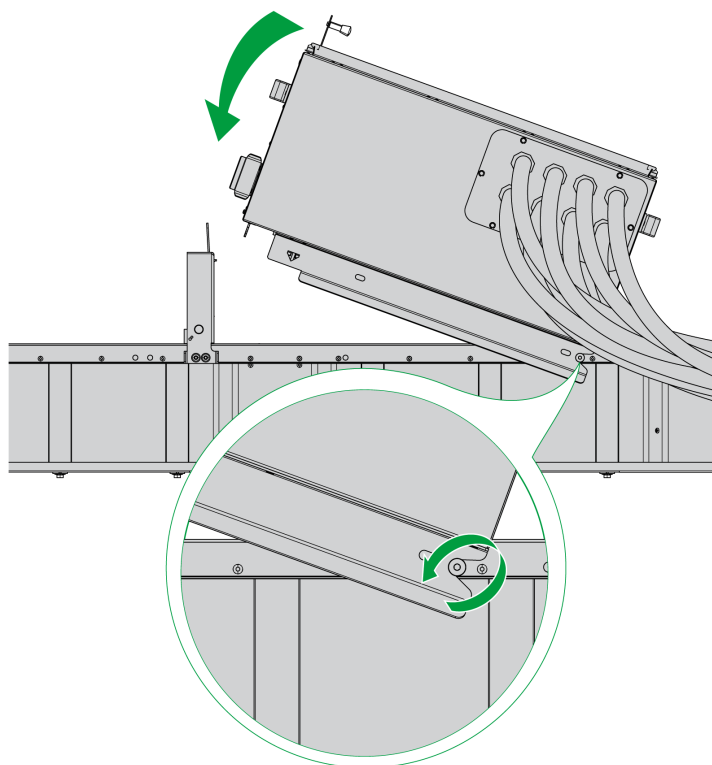

Positions of the Tap-Off Unit With Automatic Clamping System

The tap-off unit with automatic clamping system can be clamped in two stable positions:

- **Disconnected position:** The tap-off unit is not connected to the mains. It can remain clamped in this disconnected position before being plugged into the run component.

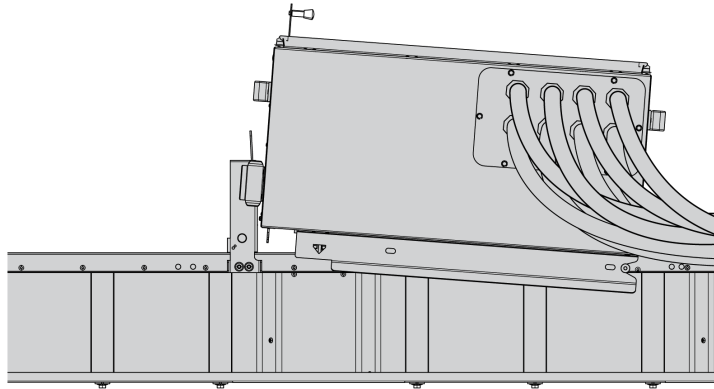

- **Connected position:** The tap-off unit is connected to the mains.

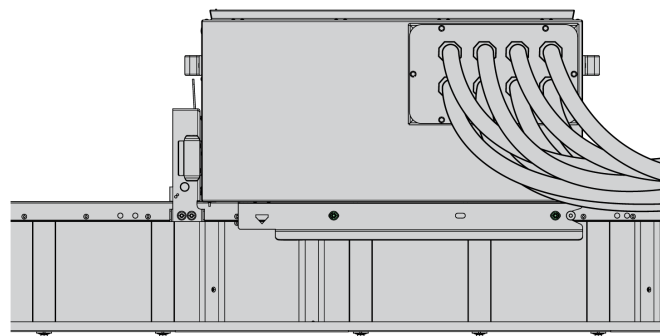

Installation of Bolted Tap-Off Units

Introduction

Tap-off units are used to connect loads or secondary runs. They comply with installation standards and regulations (IEC 60364) irrespective of the earthing system (TT, TNS, TNC, or IT).

Bolted tap-off units can be plugged into and removed from the run component when the run component is not energized.

The bolted tap-off units from the Canalis KS systems are compatible for use with the Canalis KT system.

⚡⚠ DANGER

HAZARD OF ELECTRIC SHOCK, EXPLOSION, OR ARC FLASH

- Beware of potential hazards.
- Do not install a bolted tap-off unit on energized run components.
- Always use a properly rated voltage sensing device to confirm power is off.
- Do not open or close the cover of a tap-off unit with the downstream load energized.
- Carefully inspect the work area for tools and objects that can be left inside the tap-off unit.

Failure to follow these instructions will result in death or serious injury.

Procedure

The procedure for installing bolted tap-off units is described in the following instruction sheets listed in the following table:

Device installed in bolted tap-off unit	Tap-off unit rating	Catalog number	Instruction sheet
ComPacT NSX circuit breaker	630 A	KTB0630CB•	AAV32052
	1000 A	KTB1000CB•	
	1250 A	KTB1250CB•	BBV39803
Isolator for blade-type fuses	630 A	KTB0630HF•	AAV82964
	1000 A	KTB1000HF•	

To install the bolted tap-off units:

1. Open the tap-off unit cover.
2. Install the protection device in the tap-off unit.

NOTE: In tap-off units with PEN, you can remove the connection between the neutral and earth, if needed.
3. Verify that the protection device is switched off and carefully inspect the tap-off unit for tools and objects that can be left inside the tap-off unit.
4. Ensure that the run component is not energized. Always use a properly rated voltage sensing device to confirm that the power is off.
5. Remove the IP protection on the outlet of the run component.
6. Plug the tap-off unit into the run component.
7. Screw the tap-off unit onto the run component.
8. Slide the bolt access shutter on the tap-off unit to align the holes and provide access to the connection bolt.

9. Tighten the connection bolt of the tap-off unit to a torque of 100 N•m to provide the electrical connection, page 61.
10. Slide back the bolt access shutter to prevent access to the connection bolt.
11. Prepare the output cable glands and connect the cables to the tap-off unit.
12. Close the tap-off unit cover.

The system and load are ready to be energized.

Rules for Tightening the Connection Bolt of the Tap-Off Unit

Correct tightening of the bolts of the tap-off unit enables the electrical connection. Follow these rules when tightening the bolts:

- The connection bolt must be tightened to a torque of 100 N•m, using the appropriate torque wrench.

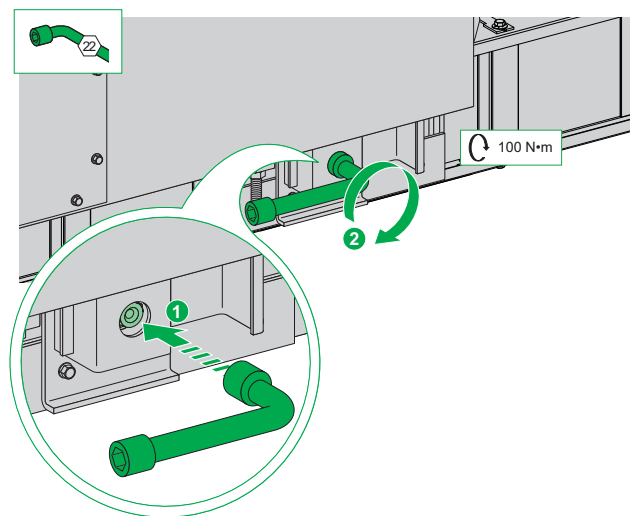

- When the correct tightening torque is reached, the nut head snaps off, freeing a red washer (shear nuts). The freed red washer falls off.

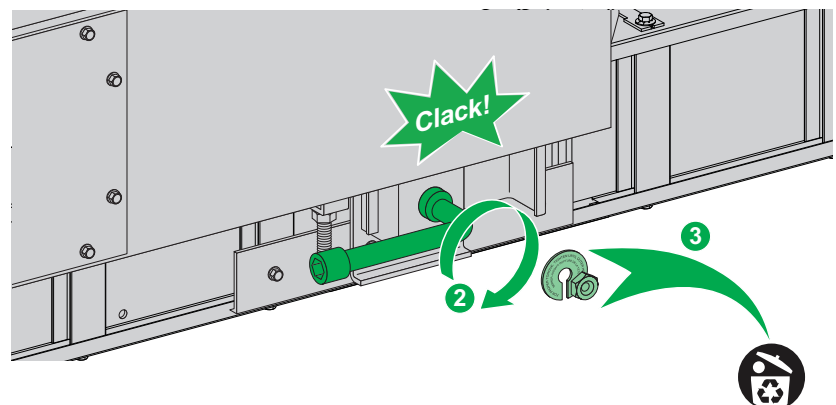

- The bolt is properly tightened only if the red washer is absent after the procedure.
- For dismantling or maintenance operations, the nut has a second head.

NOTE: If the bolted tap-off unit is dismantled and reassembled at installation or for maintenance, ensure the torque of 100 N•m with a torque wrench.

Installation of Specific Components

What's in This Part

Installation of Expansion Units.....	63
Installation of Fire-Barrier Kit.....	67

Installation of Expansion Units

Introduction

The expansion unit controls and absorbs the expansion of run components. Expansion units have the following features:

- The expansion unit is 1 m in length and must be fitted horizontally.
- The expansion unit is equipped with flexible conductor joints and a sliding case at its center. These absorb the relative movements of the section that the expansion unit is installed in.

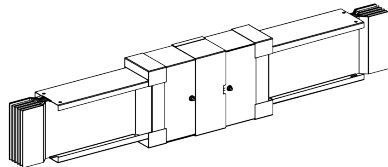

The expansion units are used in the following cases:

- The run is made up of straight sections longer than 30 m: The expansion unit absorbs length variations of the run components caused by temperature variations.
- The run passes through an expansion joint between two buildings: The expansion unit absorbs the forces caused by movement of the two buildings relative to each other.

Procedure

The procedure for installing expansion units is the same as the procedure for installing run components on horizontal supports, refer to *Installation of Horizontal Run Components on Supports*, page 27. For more information refer to the AAV32038 instruction sheet.

Expansion Units on Long Runs

If the run length is greater than 30 m, provide expansion units and appropriate means of anchoring.

To ensure that expansion is directed toward the expansion units, the ends of straight sections, and in some cases the center, must be anchored. This means that:

- A straight section containing an expansion unit must be free from all longitudinal movement on its supports.
- The straight section must be rigidly anchored at the ends that are not joined to the expansion unit.
- If more than one expansion unit is installed on a straight section, the section must be rigidly anchored between the expansion units.

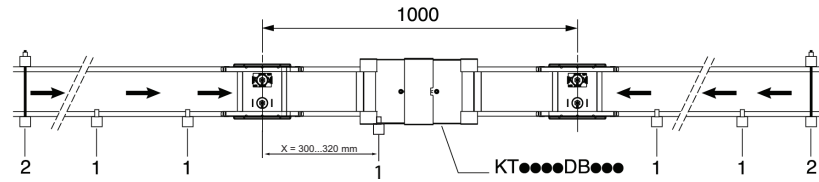

- 1 Free supports
- 2 Anchored supports
- ← Direction of expansion

Number of Expansion Units According to the Run Length

The following table lists the expansion units for horizontal runs without tap-off units:

Run length	Number of expansion units	Configuration
0...30 m	0	
31...60 m	1	
61...90 m	2	
91...120 m	3	
	Anchor point	
	Expansion unit	
	Direction of expansion	

The following table lists the expansion units for horizontal runs with tap-off units:

Run length	Number of expansion units	Configuration
0...30 m	0	
31...60 m	1	
61...120 m	2	
	Anchor point	
	Expansion unit	
	Direction of expansion	
	Tap-off unit	

Expansion Units on Transformer and Switchboard Links

In transformer or switchboard links, provide a rigid anchor just before the run component that is connected to the end feed units. Provide for expansion units every 30 m of straight run length (L).

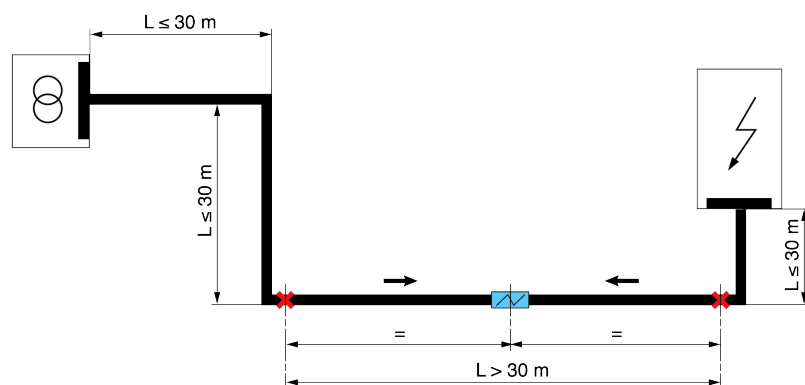

- Anchor point
- Expansion unit
- Direction of expansion

Expansion Units Between Two Buildings

The expansion unit installed between two buildings is used to absorb the forces arising due to the movement of the two buildings relative to each other.

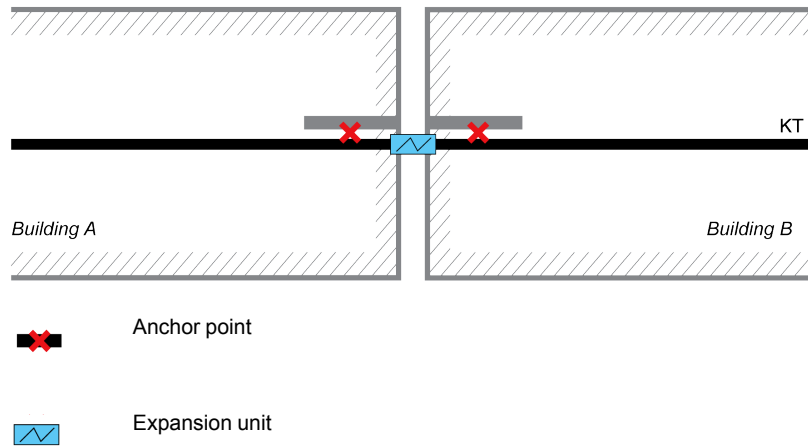

Anchoring the Run Components

The run components can be anchored to the supports using accessories as shown:

Edgewise assembly

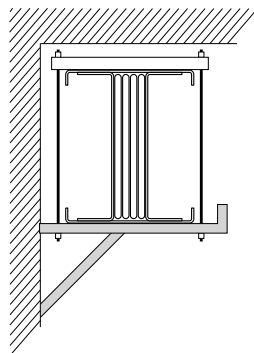

Flatwise assembly

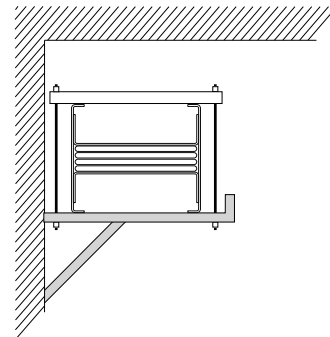

NOTE: Accessories to anchor the run components on the supports are not provided by Schneider Electric.

Installation of Fire-Barrier Kit

Introduction

Where Canalis KT system passes through a partition wall or a floor slab, it inherently acts as a fire barrier for up to 30 minutes. For greater protection levels of up to 120 minutes, a fire-barrier kit must be installed.

⚠ CAUTION

HAZARD OF IRRITATION

Wear suitable Personal Protective Equipment (PPE), including gloves, goggles, and a protective mask while installing the fire-barrier kit.

Failure to follow these instructions can result in injury or equipment damage.

Procedure

The procedure for installing the fire-barrier kit is described in the S1A68982 instruction sheet.

1. Check the dimensions of the hole through the partition wall or floor slab.
2. Define the position of the fire-barrier kit on the run component. The fire-barrier kit must be positioned more than 200 mm from any joint block, refer to *Fire Barrier Position*, page 68.
3. Install the fire-barrier kit around the run component. If the fire-barrier kit is installed around a run component with lateral reinforcement, then the components of the fire-barrier kit must be cut accordingly.
4. After installing the fire-barrier kit, use mortar or fire-resistant plaster to fill the gaps between its component parts.

The material used to fill the gaps must meet the applicable requirements in force to maintain the fire-resistance rating of the partition wall or floor slab. For example, DIN 1045 and DIN 1053-1.

5. Install the run component with the fire-barrier kit on supports, through the partition wall or floor slab.
Do not place any support directly under the fire-barrier kit.
6. Install the KTA5000 and KTC6300 run components with two fire barrier kits, one for each run component, refer to *Fire Barrier Position*, page 68.
7. After installing the run component, use mortar or fire-resistant plaster to fill the hole around and outside the fire-barrier kit.

The material used to fill the hole must meet the applicable requirements in force to maintain the fire-resistance rating of the partition wall or floor slab. (for example, DIN 1045 and DIN 1053-1)

Fire Barrier Position

Consider the following guidelines when installing the fire-barrier kit:

- Position the fire-barrier kit more than 200 mm from any joint block.
- Adjust the position of the fire-barrier kit on a horizontal or vertical run component with respect to the partition wall or floor slab as indicated in the following graphic.

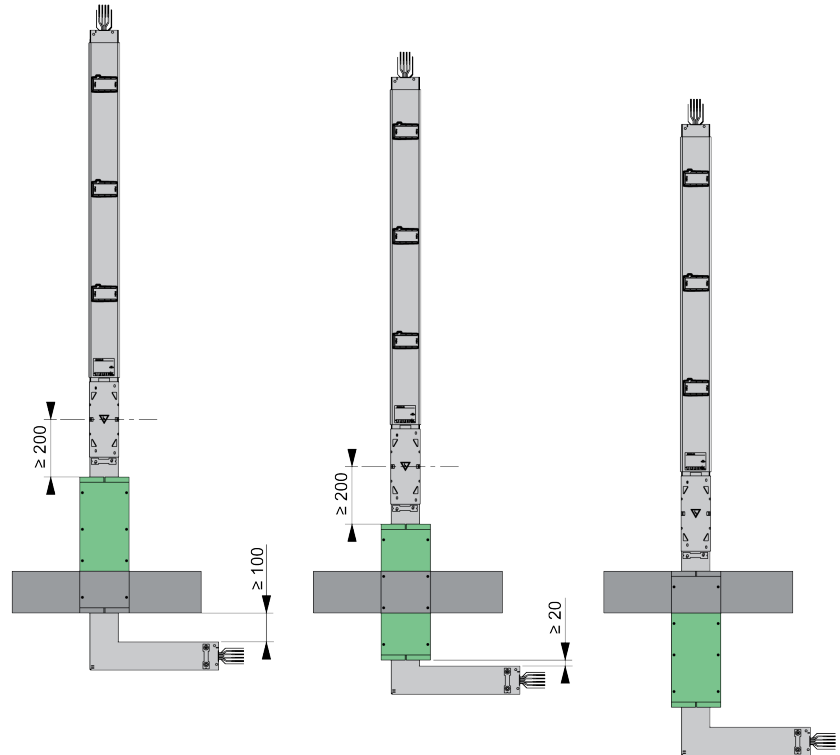

Installing KTA5000 or KTC6300 Fire Barriers

As the Canalis KTA5000 or KTC6300 are made of two run components, the fire barrier kits for Canalis KTA5000 or KTC6300 are made of two fire barriers, one for each run component.

The distance between both run components must be 130 mm. Install both the fire barriers side by side and seal together with fire barrier sealant KTB0000SC1 supplied with the KTB0622CF• fire barrier kit.

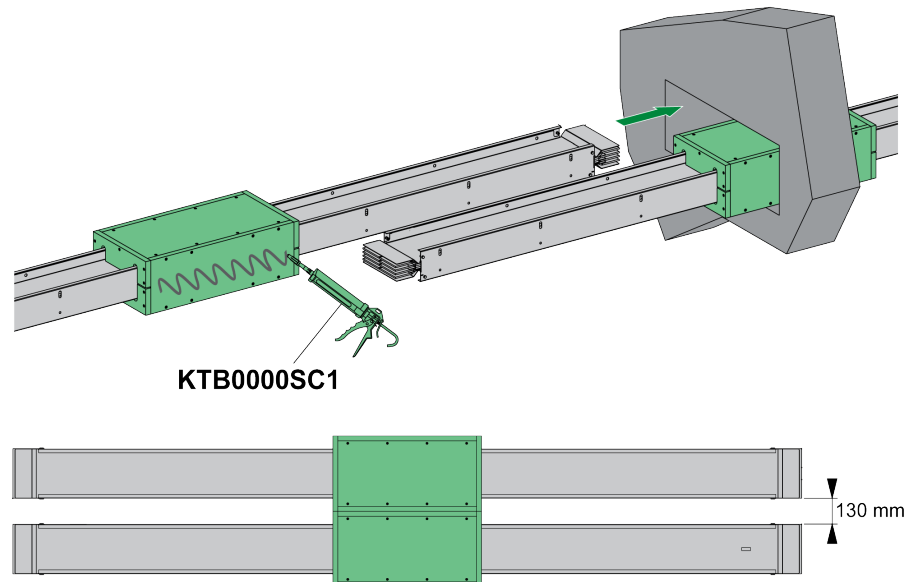

Commissioning and Maintenance

What's in This Part

Commissioning	71
Commissioning Check-list Before Energizing	74
Maintenance	76

Commissioning

Safety Instructions

DANGER

HAZARD OF ELECTRIC SHOCK, BURN, OR EXPLOSION

- Only qualified electrical maintenance personnel should install, operate, service, or maintain this equipment.
- Perform such work only after reading and understanding all the instructions contained in the following table.
- Turn off all the power supplies of this equipment before working on or inside the equipment.
- Always use a properly rated voltage sensing device to confirm power is off.
- Beware of potential hazards and take adequate safety precautions.

Failure to follow these instructions will result in death or serious injury.

Tests Before Energizing

Carry out the following tests before energizing the busbar trunking system. Record the test results in the checklist provided in *Commissioning Check-list Before Energizing*, page 74.

NOTE: All the operations described in the following table are given for indication only. Under no circumstances can they be used to substitute the installation company's own procedures and engage Schneider Electric's responsibility.

Step	Test	Description
1	Support and alignment check	<p>It is recommended to perform a final validation before energizing the system to ensure that all the installation rules are followed.</p> <p>Verify:</p> <ul style="list-style-type: none"> The distance between the supports and their positions along the line. The localization of the junctions. Blocking points that can affect the expansion movements. The degree of IP protection rating.
2	Phase order and label check	<p>Perform a visual inspection of the phase order from end to end. Ensure that the phase or neutral crossovers are installed.</p> <p>Verify all the labels.</p>
3	Connection check	<ul style="list-style-type: none"> Perform a visual inspection on the tightening of the joint block bolts. All shear nuts should have the double-headed bolts snapped off and the red washers absent. If the joint block is dismantled and reassembled for any reason, the 60 N•m torque must be checked again with a torque wrench. Check the PE protective circuit equipollently (according to the standard IEC 61439-1). <p>Using an ohmmeter, check the PE protective circuit continuity by visual inspection and random continuity testing. This test is carried out to detect the wrong mounting of the PE plate, for example, accidental insertion in the phase joint block.</p>
4	Insulation check (before transformer and switchboard connections)	<ul style="list-style-type: none"> Measure the insulation resistance between each phase or neutral⁽¹⁾ and earth (if the casing is connected to earth). <p>The insulation resistance must be 1 MΩ or higher according to the IEC 60364-6 and IEC 61.3.3 standards.</p> <p>NOTE: Use a megger rated at 500 Vdc if $U_e \leq 500$ Vdc or 1000 Vdc if $U_e \leq 1000$ V (DC to avoid capacitive currents).</p>

Step	Test	Description
		<ul style="list-style-type: none"> Perform a general visual inspection of the earth network. Verify: <ul style="list-style-type: none"> The galvanized steel casing sides are earthed. This depends on the earthing system. The connection quality. The cable cross-section. There are no loose metal parts (washers, screws) in the tap-off units.
5	Transformer and switchboard connections check	<ul style="list-style-type: none"> Reconnect each link to the upstream transformer. Perform a visual inspection on the tightening of the connection bolts at transformers and switchboards. The torque to apply depends on the screw size. Mark each tightened nut using indelible varnish. Perform the insulation check between each phase or neutral⁽¹⁾ and earth, as described in step 4. <p>NOTE: Once the transformer is reconnected (star secondary), the phase-earth measurement is the winding resistance.</p> Using a Roto-phase or 3-phase harmonic analyzer (CA8334 or Fluke 434), perform a phase order check. This is to detect any inversion of the phases or neutral among the four incoming and outgoing connections of the busbar trunking system, with respect to the transformer output.
6	Protection settings check	<ul style="list-style-type: none"> Ensure that the upstream circuit breaker protection settings are in accordance with the installation drawing specifications and the protection plan of the busbar trunking system. perform compliance checks of the following, in accordance with the installation drawing specifications: <ul style="list-style-type: none"> I_{max} thermal I_n magnetic <p>NOTE: Perform this check only if the busbar trunking system is commissioned at the same time as the transformer. The upstream circuit breaker protection setting checks are related to transformer commissioning.</p> <p>NOTE: If this check is successful, the busbar trunking system busbar trunking system can be commissioned and the energized operating tests performed with the appropriate protective equipment.</p>
7	Tap-off units check	<ul style="list-style-type: none"> Ensure that all the tap-off units are disconnected or isolated in off-load position. Ensure that the protective devices are correctly rated (current, breaking capacity) with respect to the loads supplied, or in accordance with the specification drawings.
<p>⁽¹⁾ No neutral insulation check is required if the earthing system is such that the neutral is connected to or used as the earth.</p>		

Energizing the Equipment

DANGER

HAZARD OF ELECTRIC SHOCK, BURN, OR EXPLOSION

Perform the tests to detect any short circuit or earth fault caused by incorrect installation before energizing the busbar trunking system.

Failure to follow these instructions will result in death or serious injury.

Follow these rules to energize the busbar trunking system:

- The busbar trunking system must carry no electrical load when it is energized. As the busbar trunking system may typically extend through several rooms and floors, verify that all devices fed from the busbar trunking system are in the OFF position.
- Energize the busbar trunking system in sequence, by starting at the source end and working towards the load end. Start by energizing the main devices, feeder devices, and then branch-circuit devices. Turn the devices to the ON position with a firm positive motion.
- After the busbar trunking system is energized, equipment such as lights, contractors, heaters, and motors can be switched on.

- It is normal for the busbar trunking system to emit a low-intensity hum during operation.
- Excessive noise can be an indication of a potential problem.

If this occurs, it is recommended to:

- Perform an audio or visual inspection of busbar trunking system to locate source of origin of noise and to check for installation errors. For example, loose hardware, housing damage, misalignments and so on.
 - If cause of noise is detected, determine actions necessary to address causes for excessive noise.
 - If source or cause of excessive noise cannot be detected, contact Schneider Electric for assistance.
- Occurrence of sparking at any point along the busbar trunking system is not normal. If this occurs, do the following:
 - De-energize the busbar trunking system immediately.
 - Rectify the cause of the sparking.
 - Perform an insulation check again, as described in step 4, refer to Tests Before Energizing, page 71 before attempting to energize.

Commissioning Check-list Before Energizing

How to Use the Check-list

Download the QGH3492102 checklist or print the checklist and use it to record the results of the commissioning tests.

Select the check box against the column **Yes** when the test is performed and is conclusive.

For a detailed description of the tests, refer to *Commissioning*, page 71. Perform the relevant tests, depending on the Canalis KT line configuration. When the tests are satisfactorily completed, sign the checklist with date.

Checklist

Recommended Checks to be Done on a Canalis KT Line Before Energization

Project: _____

Line: _____ **Drawing number:** _____ **Rev:** _____

Busbar trunking type, rating, and polarity: _____

Installation company: _____ **Installers:** _____

Verification company: _____ **Verified by:** _____

Installation can be energized: Yes No **Date:** _____

For more information on recommended checks, refer to the Canalis KT installation manual [QGH3492101](#).



Signature: _____

N°	Topics	Yes	No	Comments
Support and Alignment Check				
1	Each construction structure, fixation device, and anchorage is strong enough to support the weight of the busbar + 90 kg.	<input type="checkbox"/>	<input type="checkbox"/>	
2	Each run component is at a minimum distance of 100 mm from the wall.	<input type="checkbox"/>	<input type="checkbox"/>	
3	Each run component is at a minimum distance of 100 mm from the ceiling.	<input type="checkbox"/>	<input type="checkbox"/>	
4	Each run component is at a minimum distance of 100 mm from another run component.	<input type="checkbox"/>	<input type="checkbox"/>	
5	Each run component is properly levelled and aligned. (refer to the instruction sheet AAV32038).	<input type="checkbox"/>	<input type="checkbox"/>	
6	Each run component is supported (refer to the relevant instruction sheet for exceptions).	<input type="checkbox"/>	<input type="checkbox"/>	
7	Each straight component is supported with a maximum distance of 3 m edgewise or 2 m flatwise, with a maximum distance of 400 mm from the junction axis.	<input type="checkbox"/>	<input type="checkbox"/>	
8	Each elbow or zed is supported individually (refer to the relevant instruction sheet for exceptions).	<input type="checkbox"/>	<input type="checkbox"/>	
9	No support is positioned under a joint block.	<input type="checkbox"/>	<input type="checkbox"/>	
10	No support is positioned in front of an outlet or a future tap-off unit.	<input type="checkbox"/>	<input type="checkbox"/>	
11	Each component is free from longitudinal movement on its supports.	<input type="checkbox"/>	<input type="checkbox"/>	
12	No visible deformation can impact the insulation and IP protection rating.	<input type="checkbox"/>	<input type="checkbox"/>	
13	Spring compression of the vertical hangers has been correctly adjusted and the nuts on the springs in the support are removed.	<input type="checkbox"/>	<input type="checkbox"/>	
14	No junction block is covered by a fire-barrier.	<input type="checkbox"/>	<input type="checkbox"/>	

Phase Order and Label Check			
15	Each run component and its junction blocks has the correct rating and polarity.	<input type="checkbox"/>	<input type="checkbox"/>
16	Each run component has the correct phase order labelling.	<input type="checkbox"/>	<input type="checkbox"/>
17	All the neutral conductors are positioned on the same side.	<input type="checkbox"/>	<input type="checkbox"/>
18	Phase order is consistent between the end feed units.	<input type="checkbox"/>	<input type="checkbox"/>
19	Phase order is correct before and after a phase or neutral crossover unit.	<input type="checkbox"/>	<input type="checkbox"/>
Connection Check			
20	At the junction: • active conductors are well placed in the joint block. • two metallic sides (PE) are well placed in the joint block.	<input type="checkbox"/>	<input type="checkbox"/>
21	Alignment at the junction between the metallic side and gasket is correct to insure the IP55 protection rating.	<input type="checkbox"/>	<input type="checkbox"/>
22	All bolts of the joint block have been tightened to remove the red washer.	<input type="checkbox"/>	<input type="checkbox"/>
23	All bolts of reassembled joint blocks have been checked with a torque wrench at a torque of 60 N•m.	<input type="checkbox"/>	<input type="checkbox"/>
			Total number of junctions:
			Total number of reassembled joint blocks:
Insulation Check (Before Transformer and Switchboard Connections)			
24	No moisture is present between the conductors before connection.	<input type="checkbox"/>	<input type="checkbox"/>
25	The insulation resistance between L1 and L2 is > 1 MΩ.	<input type="checkbox"/>	<input type="checkbox"/>
26	The insulation resistance between L1 and L3 is > 1 MΩ.	<input type="checkbox"/>	<input type="checkbox"/>
27	The insulation resistance between L2 and L3 is > 1 MΩ.	<input type="checkbox"/>	<input type="checkbox"/>
28	The insulation resistance between L1 and N is > 1 MΩ.	<input type="checkbox"/>	<input type="checkbox"/>
29	The insulation resistance between L2 and N is > 1 MΩ.	<input type="checkbox"/>	<input type="checkbox"/>
30	The insulation resistance between L3 and N is > 1 MΩ.	<input type="checkbox"/>	<input type="checkbox"/>
31	The insulation resistance between L1 and PE is > 1 MΩ.	<input type="checkbox"/>	<input type="checkbox"/>
32	The insulation resistance between L2 and PE is > 1 MΩ.	<input type="checkbox"/>	<input type="checkbox"/>
33	The insulation resistance between L3 and PE is > 1 MΩ.	<input type="checkbox"/>	<input type="checkbox"/>
34	The insulation resistance between N and PE is > 1 MΩ.	<input type="checkbox"/>	<input type="checkbox"/>
Transformer and Switchboard Connections Check			
35	Transformers or switchboards do not support the weight of the busbar.	<input type="checkbox"/>	<input type="checkbox"/>
36	Position of the neutral is correct.	<input type="checkbox"/>	<input type="checkbox"/>
37	Phase order is correct.	<input type="checkbox"/>	<input type="checkbox"/>
38	Number and cross-section of the connection bars are as designed.	<input type="checkbox"/>	<input type="checkbox"/>
39	Clearance between active conductors is > 14 mm.	<input type="checkbox"/>	<input type="checkbox"/>
40	Clearance between active conductors and enclosures is > 20 mm (even if the standard required is 14 mm).	<input type="checkbox"/>	<input type="checkbox"/>
41	Number and distance between bar supports can insure short-circuit withstand and clearance.	<input type="checkbox"/>	<input type="checkbox"/>
42	PE or PEN bonds are properly connected to the equipment's earthing terminal.	<input type="checkbox"/>	<input type="checkbox"/>
43	All bolts have been tightened at the proper torque (the torque depends on the screw size). Verified bolts are marked with varnish.	<input type="checkbox"/>	<input type="checkbox"/>
44	Each box has been closed with its cover plate to insure the IP55 protection rating.	<input type="checkbox"/>	<input type="checkbox"/>

Maintenance

Safety Instructions

DANGER

HAZARD OF ELECTRIC SHOCK, BURNS, OR EXPLOSION

- Only qualified electrical maintenance personnel should install, operate, service or maintain this equipment.
- A qualified person is one who has skills and knowledge related to the construction and operation of electrical equipment and its installation, and has received safety training to recognize and avoid the hazards involved.
- This document should not be viewed as sufficient for those who are not otherwise qualified to operate, service, or maintain the equipment discussed.
- The successful operation of this equipment depends upon proper handling, installation, operation, and maintenance.

Failure to follow these instructions will result in death or serious injury.

WARNING

HAZARD OF ELECTRIC SHOCK, BURNS, OR EQUIPMENT DAMAGE

Perform an immediate inspection, in event of electrical fault, fire, water leakage, earthquake or any similar untoward event.

Failure to follow these instructions can result in death, serious injury, or equipment damage.

Overview

The frequency and the level of maintenance of the Canalis KT system depends on the criticality of the application and the environmental conditions. The recommendations in this section concern only the busbar trunking system. For all devices fitted in tap-off units, the recommendations of the manufacturer must be complied with.

Basic Maintenance Procedures

Basic maintenance must be performed every year, for all types of applications, and under all conditions.

Perform the following procedures for basic maintenance:

- Inspect the external appearance of the components, accessories, and supports.
- Check for deformation, damage, or dirt.
- Check for dislocation, bending, misalignment, and other abnormalities of the connecting covers, hangers, and plug-in units.
- Check if the joint blocks or terminals are discoloured, corroded or pitted, or show signs that they are exposed to high temperatures.
- Check for any changes in the environment that can affect the busbar trunking system operation. These include the presence or appearance of water, moisture, high temperature, corrosive gas, excessive vibration, dust, air circulation, or new hot air sources.

- Inspect the external appearance of tap-off units.
- Remove dust, water, oil deposits, and all other conductive bodies from the sensitive zones.
- The contacts between the busbar trunking system and tap-off units do not need specific maintenance. The contacts consist of sprung silver plated contact jaws to ensure optimum contact quality.

Procedures for Critical Installations

More specific maintenance procedures must be performed when the busbar trunking system feeds critical applications or in case of unfavorable environmental conditions.

Critical applications include those with the need for high level of continuity of service, such as secured power distribution in hospitals, IT data centers, cooling power supplies, or similar applications with a high load factor.







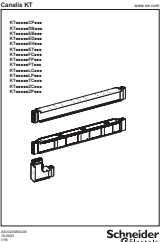

Unfavorable conditions include high ambient temperature, high level of humidity, dusty or polluted environments, and intensive vibrations.

Perform the following maintenance procedures in critical environments:

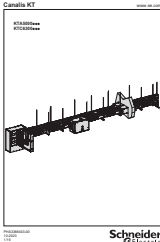

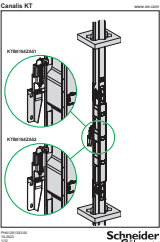

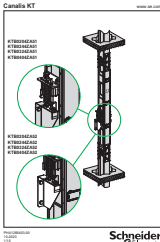



- Perform the basic maintenance procedures every year as described previously.
- Verify that there is no abnormal increase in ambient temperature.
- If the busbar trunking system is accessible, perform infrared temperature measurements on all the electrical connections (joint blocks, terminal connections, and tap-off units).
- If the busbar trunking system is not accessible, install a thermal monitoring system which communicates temperatures to a remote supervision point.
- In case of abnormal temperature measurement results, check all the connections using a torque wrench. The torque for the joint block bolts must be 60 N•m ($\pm 10\%$). If these values decrease significantly over time, contact Schneider Electric.
- If needed, the concerned material must be replaced with new factory-mounted products. contact your local Schneider Electric office for all replacements.
- Before re-energizing the busbar trunking system, carry out an insulation test as described in the commissioning section, refer to [Commissioning, page 71](#).
- After all the necessary inspections and repairs mentioned above, perform infrared temperature measurements on all the electrical connections.

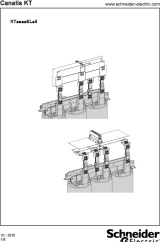

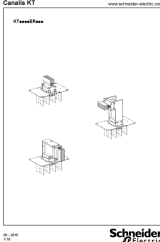

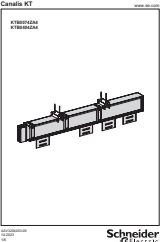

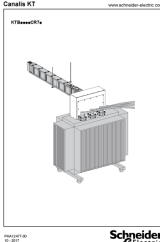



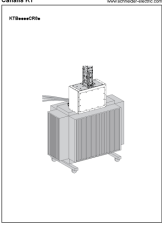

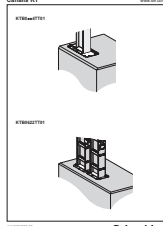

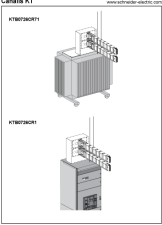

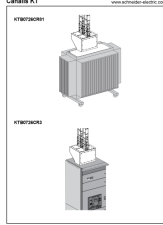
List of Instruction Sheets

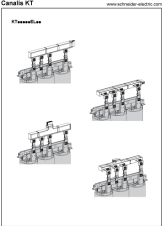
Instruction Sheets for Supports and Run Components

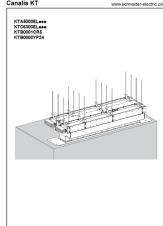



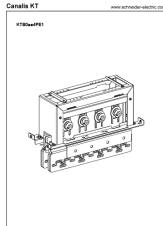





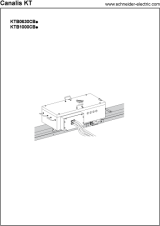

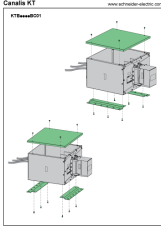

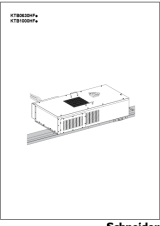

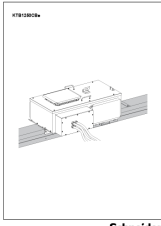

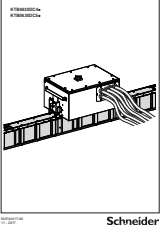

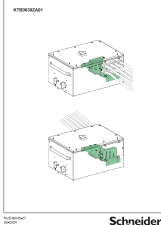
Front page	QR code and web link	Front page	QR code and web link
	 AAV32038		 PHA33884
	 PHA12613		 PHA12664

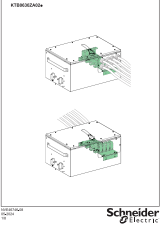
Instruction Sheets for Transformer and Switchboard Connections

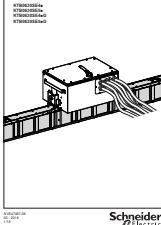

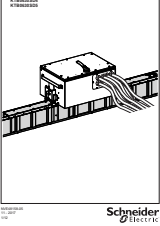
Front page	QR code and web link	Front page	QR code and web link
	 AAV32030		 AAV17625
	 AAV32042		 PHA12477

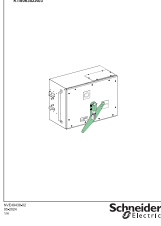
Front page	QR code and web link	Front page	QR code and web link
 <p>Canalis KT www.schneider-electric.com PHA12478 Schneider Electric</p>	 <p>PHA12478</p>	 <p>Canalis KT www.schneider-electric.com AAV32049 Schneider Electric</p>	 <p>AAV32049</p>
 <p>Canalis KT www.schneider-electric.com PHA44577 Schneider Electric</p>	 <p>PHA44577</p>	 <p>Canalis KT www.schneider-electric.com PHA44578 Schneider Electric</p>	 <p>PHA44578</p>
 <p>Canalis KT www.schneider-electric.com AAV32054 Schneider Electric</p>	 <p>AAV32054</p>	 <p>Canalis KT www.schneider-electric.com PHA44575 Schneider Electric</p>	 <p>PHA44575</p>
 <p>Canalis KT www.schneider-electric.com PHA44576 Schneider Electric</p>	 <p>PHA44576</p>	 <p>Canalis KT www.schneider-electric.com S1A32783 Schneider Electric</p>	 <p>S1A32783</p>





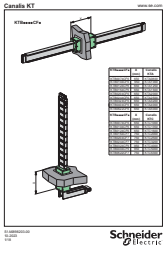



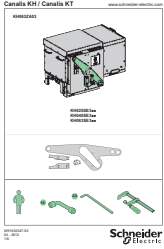

Instruction Sheets for Tap-Off Units

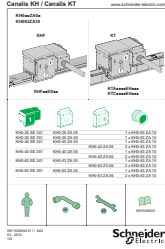
Front page	QR code and web link	Front page	QR code and web link
 <p>Canalis KT KT3000000 KT3000000</p> <p>Schneider Electric</p>	 <p>AAV32051</p>	 <p>Canalis KT KT3000001</p> <p>Schneider Electric</p>	 <p>AAV32052</p>
 <p>Canalis KT KT3000000 KT3000000</p> <p>Schneider Electric</p>	 <p>AAV82964</p>	 <p>Canalis KT KT3000000</p> <p>Schneider Electric</p>	 <p>BBV39803</p>
 <p>Canalis KT KT3000000 KT3000000</p> <p>Schneider Electric</p>	 <p>NVE44417</p>	 <p>Canalis KT KT3000001</p> <p>Schneider Electric</p>	 <p>NVE46045</p>
 <p>Canalis KT KT3000000 KT3000000</p> <p>Schneider Electric</p>	 <p>NVE46746</p>	 <p>Canalis KT KT3000000 KT3000000 KT3000000</p> <p>Schneider Electric</p>	 <p>NVE47487</p>
 <p>Canalis KT KT3000000 KT3000000</p> <p>Schneider Electric</p>	 <p>NVE48158</p>	 <p>Canalis KT KT3000000</p> <p>Schneider Electric</p>	 <p>NVE49438</p>

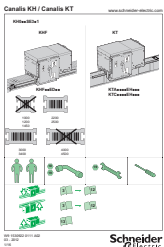

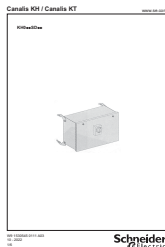

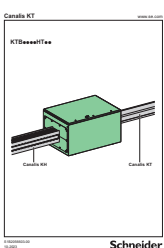
Instruction Sheets for Specific Components

Front page	QR code and web link	Front page	QR code and web link
	 S1A68982	-	-

Instruction Sheets for Canalis KH / Canalis KT Components

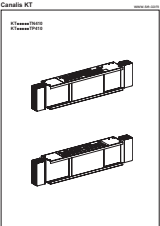
Front page	QR code and web link	Front page	QR code and web link
	 1630347		 1530944
	 1530922		 1530545
	 S1B20566	-	-

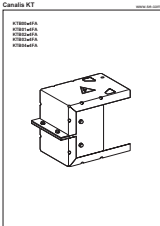
Miscellaneous Instruction Sheets

Front page	QR code and web link	Front page	QR code and web link
 <p>Canalis KT AAV20832</p> <p>Schneider Electric</p>	 <p>AAV20832</p>	 <p>Canalis KT AAV32046</p> <p>Schneider Electric</p>	 <p>AAV32046</p>

Schneider Electric
35 rue Joseph Monier
92500 Rueil Malmaison
France

www.se.com

As standards, specifications, and design change from time to time, please ask for confirmation of the information given in this publication.

© 2025 Schneider Electric. All rights reserved.

QGH3492101-04