

PowerLogic™ EM3570 Series Technical Datasheet

The PowerLogic™ EM3570 series DIN-rail-mount energy meters with Ethernet are the new benchmark for affordable and precision metering application.

Engineered on the trusted PowerLogic platform, Ethernet-enabled EM3570 DIN rail meters are designed to install easily and integrate seamlessly with existing BACnet/IP and Modbus TCP/IP networks common in today's building and power-management systems. With wide-range CT compatibility, high reliability, IEC 61557-12 and UL2808 compliance, as well as ASHRAE 90.1 for power and energy logging capability, EM3570 meters support the energy-efficiency designs of most buildings and are ideally suited for energy cost management applications.

Applications

Capable of essential cost management:

- Energy monitoring in building automation systems
- Renewable energy
- Energy management
- Commercial sub-metering
- Industrial monitoring
- Cost allocation

Also ideal for electrical network management:

- Track real-time power conditions
- Monitor control functions
- Provide basic power quality values
- Extended data log feature support up to 3 years
- Analyze equipment and network status
- BACnet/IP and Ethernet TCP/IP protocol support

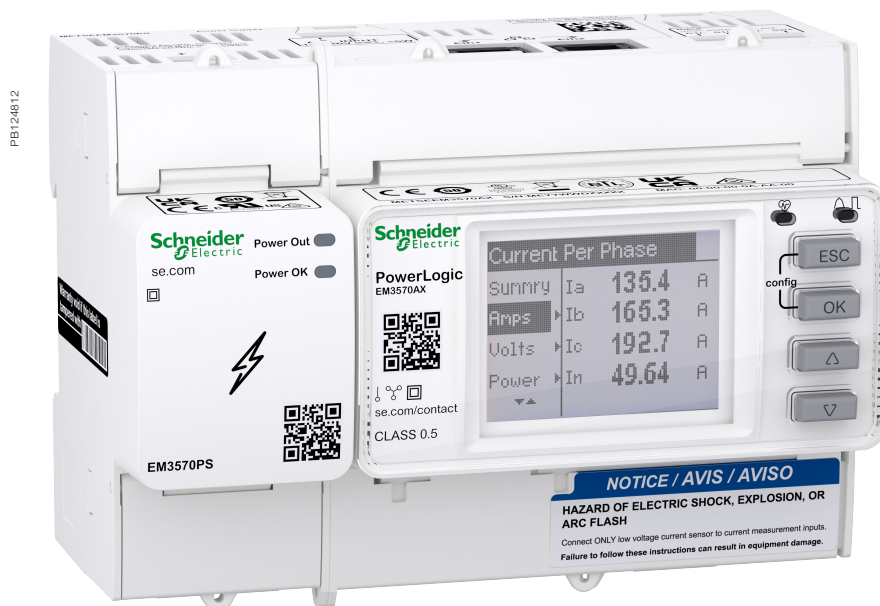

The Solution for

Markets that can benefit from a solution that includes PowerLogic™ EM3570 series meters:

- Buildings
- Industry
- Healthcare
- Data center and networks
- Infrastructure

Benefits

System integrators' benefit

- Ease of integration
- Ease of setup
- Cost effectiveness

Panel builders' benefit

- Ease of installation
- Cost-effectiveness
- Aesthetically pleasing
- Simplified ordering
- Externally powered with LVDC control power
- Digital inputs
- Relay output

End users' benefit

- Retrofitment in existing panel with Split core LVCT or Rogowski coil
- Ease of use
- Comprehensive, consistent, and superior performance
- Maximize uptime, eliminate faults, and enhance safety
- Cybersecurity features

Competitive Advantages

- Easy to install and operate
- Easy for circuit-breaker monitoring and control
- 2 GB memory for data logging up to 3 years with 16 parameters in 15 min interval. Flexibility of selecting parameters from 75 different parameters with option of setting the logging interval from 10 sec to 32767 sec
- Load management combined with alarm and timestamping
- High performance and accuracy
- Onboard BACnet/IP and Ethernet TCP/IP protocol support
- Low-voltage DC control powered for safer installation

Power Management Solutions

Schneider Electric provides innovative power management solutions to increase your energy efficiency and cost savings, maximize electrical network reliability and availability, and optimize electrical asset performance.

Features

- Open, robust communications
 - Ethernet protocol and daisy-chain functionality with two RJ45 connectors at 10/100 Mbps
 - Supports HTTPS, SNMP, DHCP, Modbus TCP/IP, BACnet/IP
 - Easy remote management through web/mobile devices
- Easy installation
 - DIN-mounted form factor option for easy, plug-in installation
 - Industry standard Modbus register and BACnet object list
- ASHRAE 90.1 compliant data logging
 - Two (2) GB capacity power and energy data logging in 15-minute increments over a 36 month period
 - Wide CT compatibility: LVCTs (0.333 V and 1 V), and Rogowski Coils (up to 5000 A)
- High reliability
 - IEC 61557-12 standards with capacity to measure up to 600 Vac
- Cybersecurity
 - Adheres to IEC 62443 SL1 requirements
 - California CA 2020
- BTL-certified BACnet communication
 - Conformance based on independent testing

Conformity of Standards

- BS/EN/IEC 61557-12:2018/AMD1:2021
- BS/EN/IEC 61326-1: edition 3
- cULus as per UL 61010-1 edition 3
- BS/EN/IEC 61010-2-30:2017
- CE and UKCA as per IEC/BS 61010-1 edition 3
- CSA 22.2 UL 61010-1:2010/2019
- CSA 22.3 61010-2-030:2017
- BACnet/IP - BTL listed (B-ASC)
- Align with cyber security guidelines as per IEC 62443

EM3570 Series



EM3570 meter front ISO view

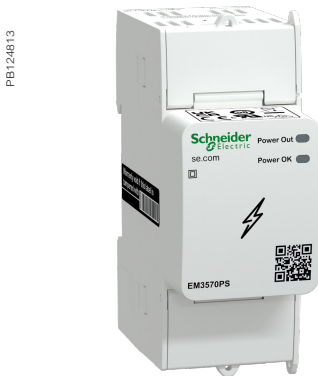

Power supply for EM3570 front ISO view

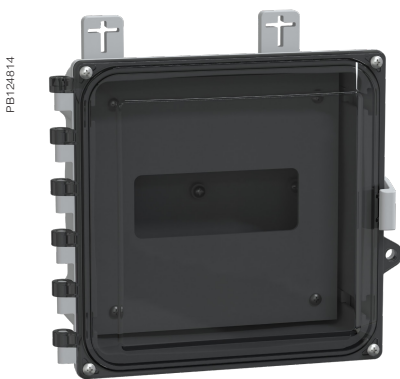

NEMA enclosure for EM3570 front ISO view

PowerLogic™ EM3570 series

The PowerLogic™ EM3570 energy meter is the ideal fit for cost management applications. Designed for use in both energy management systems and building management systems, it provides the measurement capabilities needed to allocate energy usage, perform sub-billing, pin-point energy savings, optimize equipment efficiency and utilization, and perform a high-level assessment of the power quality of the electrical network.

In a single DIN Rail mount 5 module width unit, with a graphical display, all three phases and neutral can be monitored simultaneously. The bright, anti-glare display features large characters and powerful backlighting for easy reading even in extreme lighting conditions and viewing angles. Ethernet communication ports are aligned with cybersecurity guidelines.

Applications

- Cost management: Cost saving opportunities become clear once you understand how and when your facility uses electricity. The PowerLogic™ EM3570 series meters are ideal for:
 - Sub-billing: Allows a landlord, property management firm, condominium association, homeowners association, or other multi-tenant property to bill tenants for individual measured utility (electricity) usage depending on the local regulations.
 - Cost allocation: Allocate energy costs between different departments (HVAC, indoor and outdoor lighting, refrigeration, etc.), different parts of an industrial process or different cost centres. Cost allocation systems can help you save money by making changes to your operation, better maintaining your equipment, taking advantage of pricing fluctuations, and managing your demand.
- Network management: Improving reliability of the electrical network is key for success in any business. Monitoring values such as voltage levels and power factor will help you to ensure proper operation and maintenance of your electrical network and equipment. PowerLogic™ EM3570 series meters are the perfect tool for:
 - Basic power quality monitoring: Power quality phenomena can cause undesirable effects such as heating in transformers, capacitors, motors, generators and misoperation of electronic equipment and protection devices.
 - Min/Max monitoring (with timestamp): Understanding when electrical parameters, such as voltage, current and power demand, reach maximum and minimum values that will give you the insight to correctly maintain your electrical network and assure equipment will not be damaged.
 - Alarming: alarms help you to be aware of any abnormal behavior on the electrical network in the moment it happens.
 - Data logging: reproduce the data logging mentioned feature section.

Main Characteristics

- Easy to install
 - DIN rail mount, no tools required. Compact meter with 90 mm width, current input through LVCT or Rogowski coil, connectable up to 600 V L-L without voltage transformers for installations compliant with category III.
- Easy to operate
 - Intuitive navigation with self-guided, selectable menus. Two LEDs on the meter face help the user confirm normal operation with a green LED - heartbeat/communications indicator, and the amber LED - customizable either for alarms or energy pulse outputs. Onboard web pages show real-time and logged information, and verify communications.
- Easy circuit breaker monitoring and control
 - The EM3570 provides 1 relay output (high performance Form A type) with capability to command most of the circuit breaker coils directly. For Digital Inputs, monitored switches can be wired directly to the meter.
- Alarms
 - Alarms can be visualized as Active (the ones that have picked up and did not drop out yet) or Historical (the ones that happened in the past). Alarms can be programmed and combined to trigger digital outputs and relay.
 - The EM3570 series keeps an alarm log with the active and historical alarms with date and timestamping. SMTP protocol for receiving alarm conditions via email and text. SNTP protocol for date/time network synchronization.

EM3570 Series

PB124815

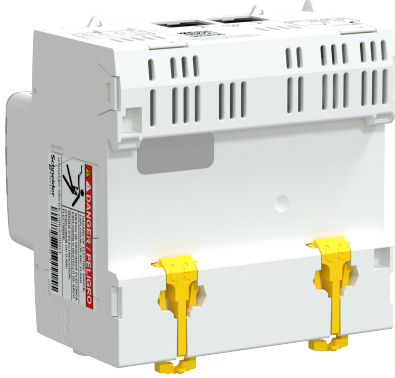

EM3570 meter rear ISO view

PB124816



Power supply for EM3570 rear ISO view

PB124817



NEMA enclosure for EM3570 rear ISO view

- High Performance and Accuracy
 - IEC 61557-12 Performance measuring and monitoring devices (PMD). Defines the performance expectation based on classes. It defines the allowable error in the class for real and reactive power and energy, frequency, current, voltage, power factor, as well as ratings for temperature, relative humidity, altitude, start-up current and safety. It makes compliant meters readings comparable - they will measure the same values when connected to the same load.
- NEMA Enclosure
 - METSEEM3570ENC enclosure offers a mounting option for EM3570 DIN Ethernet Meters with NEMA 4x level protection from the elements. The enclosure is equipped with DIN rail mounting hardware for convenient installation and a swing panel kit for electrical protection.
 - NEMA 4x level protection - weatherproofing and durability
 - Clear front panel - maximum visibility
 - Swing panel kit - clean and pleasing look
- Power Supply
 - The METSEEM3570PS Power Supply provides 24 Vdc, 0.3 A output control power to the EM3570 series power and energy meter. The power supply supports the same voltage range as the EM3570 meter.
 - Wide input range: 90 to 600 Vac (600V LL/347V LN) or 125 to 300 Vdc

Native Multi-Protocol Support

The EM3570 series is easy to integrate into new and existing BMS systems. With native BACnet/IP protocol support, meters can simultaneously communicate via BACnet and Modbus in applications where multiple software systems are used (building-management and energy-management systems).

The EM3570 series has been tested and certified in accordance with BACnet Testing Laboratories (BTL) requirements.

- EM3570 series metering:
 - Power quality analysis
 - The EM3570 offers Total Demand
- Load management
 - Peak demands with timestamping are provided. Predicted demand values can be used in combination with alarms for basic load-shedding applications.
- Alarming with timestamping
 - A different combination of set-point and drop-point driven alarms from array of 17 different alarm.

	EM3570 Series
Set point driven alarms	17
Custom defined	■

EM3570 Series

EM3570 Series Feature Selection

	METSEEM3570	METSEEM3570X	METSEEM3570A	METSEEM3570AX
Installation				
Fast installation, DIN rail mount with integrated display	■	■	■	■
Accuracy				
Class	CL 0.5	CL 0.5	CL 0.5	CL 0.5
Display				
Backlit LCD, multilingual, 4 lines, 4 concurrent values	■	■	■	■
Power and Energy Metering				
3-ph voltage, current, power, demand, energy, frequency, power factor	■	■	■	■
Multi-tariff	4	4	4	4
I/Os and Relays				
Digital inputs	2	2	2	2
Relay output	1	1	1	1
Alarms and Control				
Alarms	17	17	17	17
Set point response time, seconds	1	1	1	1
Single and multi-condition alarms	■	■	■	■
Memory for data logging	2 GB	2 GB	2 GB	2 GB
Communications				
Ethernet port with Modbus TCP protocol	■	■	■	■
BACnet/IP protocol	■	■	■	■
Onboard web server with web pages	■	■	■	■

EM3570 Commercial References

Comm. ref Numbers	Description
METSEEM3570	DIN Ethernet power meter, LVCT input with external Power Supply module
METSEEM3570A	DIN Ethernet power meter, Rogowski coil input with external Power Supply module
METSEEM3570X	DIN Ethernet power meter, LVCT input without external Power Supply module
METSEEM3570AX	DIN Ethernet power meter, Rogowski coil input without external Power Supply module
METSEEM3570PS	24V DC Power Supply Module for DIN Ethernet meter 600V AC input
METSEEM3570ENC	NEMA enclosure accessory for Din Ethernet meter METSEEM35x Schneider brand

Please contact your Schneider Electric representative for complete ordering information.

EM3570 Series

EM3570 Series Technical Specifications

	METSEEM3570	METSEEM3570X	METSEEM3570A	METSEEM3570AX
Use on LV systems		■		
Basic metering with min/max readings		■		
Instantaneous RMS Values				
Current		■		
Voltage		■		
Frequency		■		
Real, reactive, and apparent power		■		
True power factor			Signed, Four Quadrant	
Displacement PF		■		
V L-N, V L-L		■		
Calculated neutral current		■		
Energy Values				
Accumulated active, reactive and apparent energy			Received/Delivered	
Demand Value				
Current average			Present, Last, Peak, and Peak Date Time	
Active power			Present, Last, Peak, and Peak Date Time	
Reactive power			Present, Last, Peak, and Peak Date Time	
Apparent power			Present, Last, Peak, and Peak Date Time	
Peak demand with timestamping D/T for current and three powers		■		
Demand calculation method	Sliding, fixed and rolling block	■		
Synchronisation of the measurement window to input, communication command or internal clock		■		
Settable demand intervals		■		
Other Measurements				
I/O timer		■		
Operating timer		■		
Alarm counters and alarm logs		■		
Power Quality Measurements				
Calculated neutral current		■		
samples/cycle			32	
Data Recording				
Min/max of instantaneous values, plus phase identification ⁽⁺¹⁾		■		
Alarms with 1s timestamping ⁽⁺¹⁾		■		
Data logging			2GB memory up to 3 years with 16 parameters in 15 min interval. Flexibility of selecting parameters from 75 different parameters with option of setting the logging interval from 10 s to 32767 s	
Min/max log		■		
Maintenance, alarm and event logs		■		
Customisable data logs		■		
RTC with battery back up			3 years (when meter is in Power OFF condition)	
Display resolution			5 digits for Energy and other parameters with auto scaling	

EM3570 Series

EM3570 Series Technical Specifications (Contd.)

		METSEEM3570	METSEEM3570X	METSEEM3570A	METSEEM3570AX
Inputs / Outputs / Mechanical Relays					
Digital inputs		2	2	2	2
Form a relay (SPST) output		1	1	1	1
Timestamp resolution in seconds		1	1	1	1
Type of measurement: True rms on three-phase (3P, 3P + N)		■			
		METSEEM3570	METSEEM3570X	METSEEM3570A	METSEEM3570AX
Measurement accuracy	IEC 61557-12	PMD/[SD]SS/K70/0.5			
	Active energy	Class 0.5 as per BS/EN/IEC 61557-12			
	Reactive energy	Class 2.0 as per BS/EN/IEC 61557-12			
	Active power	Class 0.5 as per BS/EN/IEC 61557-12			
	Apparent power	Class 0.5 as per BS/EN/IEC 61557-12			
	Reactive power	Class 2.0 as per BS/EN/IEC 61557-12			
	Current, phase	Class 0.5 as per BS/EN/IEC 61557-12			
	Voltage, L-N	Class 0.5 as per BS/EN/IEC 61557-12			
	Frequency	Class 0.5 as per BS/EN/IEC 61557-12			
	Power factor	Class 0.5 as per IEC 61557-12/±0.005 count			
	Calculated neutral current	Class 0.5 as per IEC 61557-12			
Input-voltage (up to 1.0 MV AC max, with voltage transformer)	Nominal measured voltage range	90 V L-N/156 V L-L to 347 V L-N/600 V L-L			
	Impedance	5 MΩ			
	Frequency nominal	50 Hz/60 Hz ± 10%			
Input-current (configurable for 0.333 V or 1 V secondary CTs)	I nominal	0.333 V (0.4 V max) or 1 V nominal (1.1 V max)		Use METSECTR-series Rogowski Coils (50 to 5000 A) (CTs must be rated for use with Class 1 voltage inputs)	
	Measured amps with over range	0.00333...0.4 V or 0.01...1.1 V			
	Frequency nominal	50 Hz/60 Hz ± 10%			
DC control power	Operating range	12...36 V DC ±20 %			
	Burden	< 5 W			
Outputs	Relay outputs	Max output frequency	0.5 Hz maximum (1 s ON/1 s OFF - min times)		
		Switching current, at resistive load	5 A @250 Vac and 5 A @30 Vdc		
		Isolation	2.5 kV rms		
Status inputs	ON voltage	11...40 Vdc			
	OFF voltage	0...5 Vdc			
	Minimum pulse width	10 ms			
	Opto isolation	3.75 kV rms			
Mechanical Characteristics					
IP degree of protection (IEC 60529)		IP40 front display, IP20 body			
Dimensions W x H x D	Meter	90 x 91.4 x 70.6 mm			
	Power Supply (optional)	36 x 91.4 x 67.6 mm			
	NEMA enclosure (optional approx.)	271 x 277 x 135 mm			
Mounting position		Meter and power supply - Vertical DIN rail mount NEMA enclosure (optional) - Projection type			

EM3570 Series

EM3570 Series Technical Specifications (Contd.)

		METSEEM3570	METSEEM3570X	METSEEM3570A	METSEEM3570AX
Environmental Characteristics					
Operating temperature	Operating temperature	-25...70 °C			
	Display (reduced display performance at -25 °C)	-25...70 °C			
Storage temperature		-40...85 °C			
Humidity range		5...95 % RH at 50 °C (non-condensing)			
Pollution degree		2			
Altitude		≤ 3000 m (9842 ft) above sea level			
Mission profile / Life span		15 years, 45 °C (113 °F) 60% RH, refer Mission Profile document			
Protective treatment		Conformal coating			
Safety					
Europe		CE/UKCA as per BS/EN/IEC 61557-12, BS/EN/IEC 61326-1, BS/EN/IEC 61010-1, BS/EN/IEC 61010-2-30			
U.S. and Canada		UL/EN 61010-1, UL/EN 61010-2-030			
Measurement category (Voltage and Current inputs)		CAT III up to 400 V L-N/690 V L-L			
Dielectric		As per IEC/UL 61010-1 (Edition 3)			
Protective class		II, Double insulated for user accessible parts			
Communication					
Ethernet port speed		100 Mbps = Green/10 Mbps = Off			
Protocol		BACnet/ IP and Ethernet TCP/IP			
FTPS		Yes			
SNMP, SNTp		Yes			
HTTPS		Yes			
Firmware and language file update		Yes			
Isolation		2.5 kV rms, double insulated			
Human Machine Interface					
Display type		Monochrome Graphics LCD			
Resolution		126 x 94 pixels			
Backlight		White LED			
Keypad		4-button			
Indicator heartbeat / Communication activity		Green LED			
Energy pulse output / Active alarm (configurable)		Orange LED			
Wavelength		590...635 Nm			
Maximum pulse rate		2.5 kHz			

EM3570 Series

Note: The dimensions are in mm (in).

EM3570 Meter Dimensions

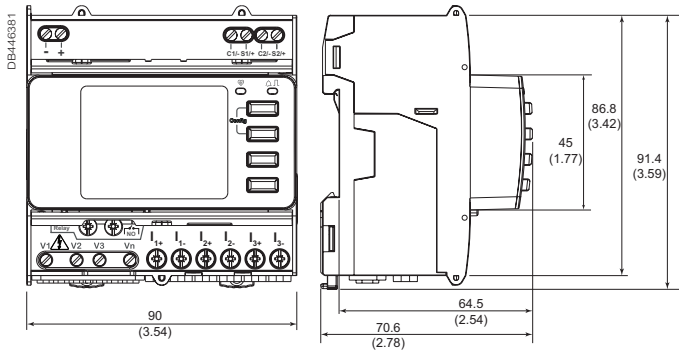

EM3570 Power Supply Dimensions

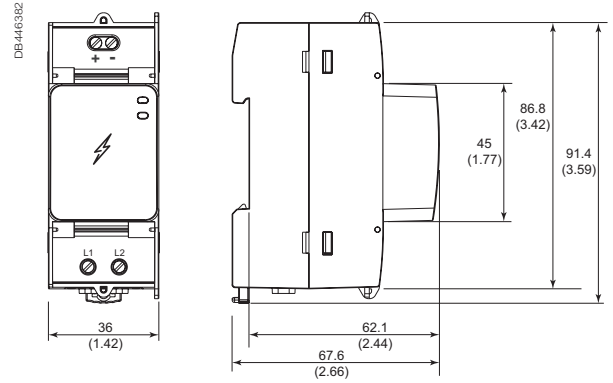

EM3570 Enclosure Dimensions

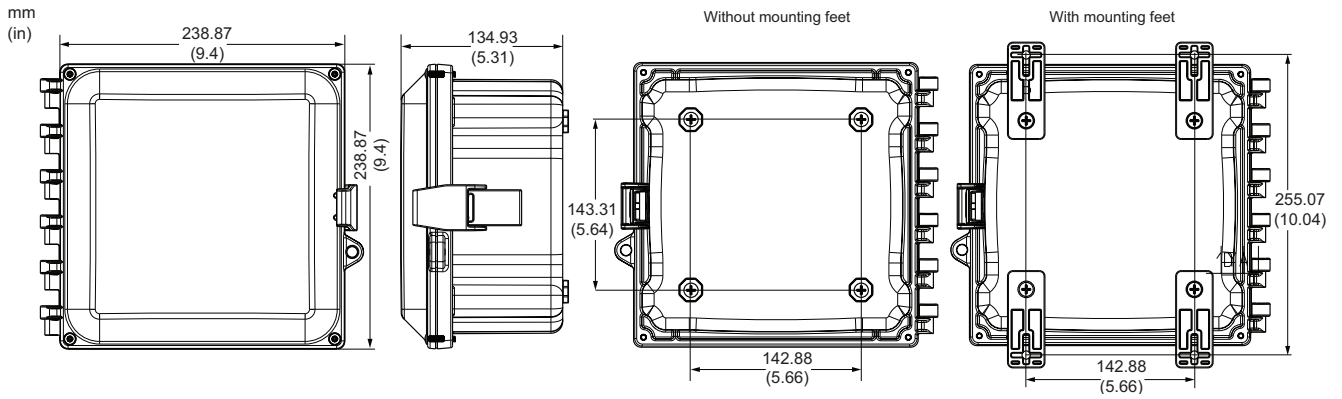

EM3570 Series

EM3570 Meter Mounting

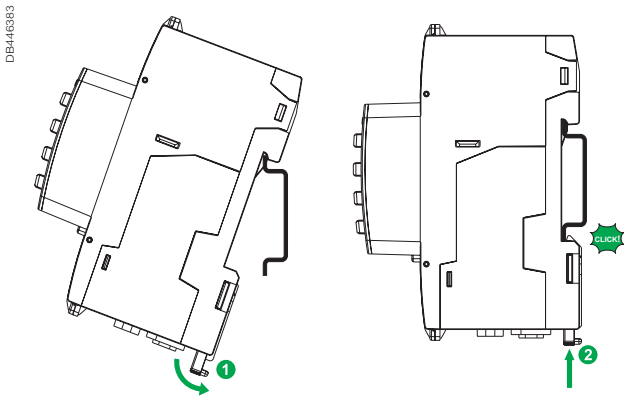

DB446385

EM3570 Power Supply Mounting

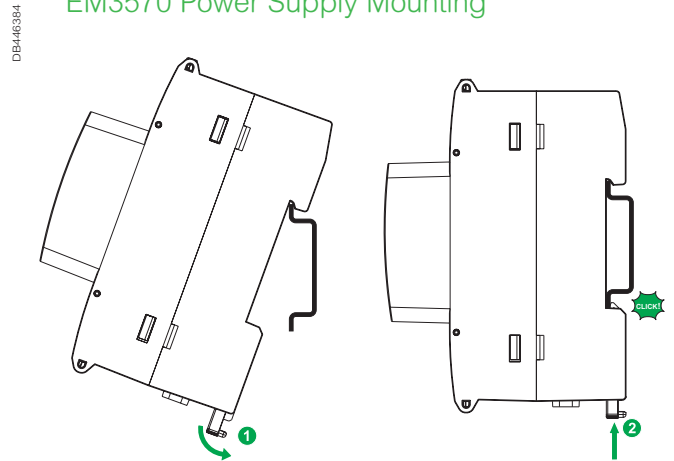

DB446384

EM3570 Power Supply Description

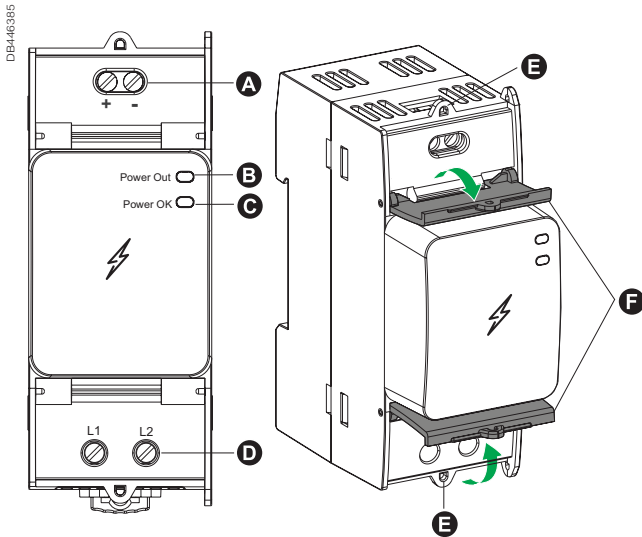

- A** 24 V DC Output (+,-)
- B** Power Out status LED
- C** Power OK status LED
- D** Input L1, L2
- E** Sealing points
- F** Sealable covers

Please see the appropriate **Installation Guide** for accurate and complete information on the installation of this product.

EM3570 Series

EM3570 Meter Description

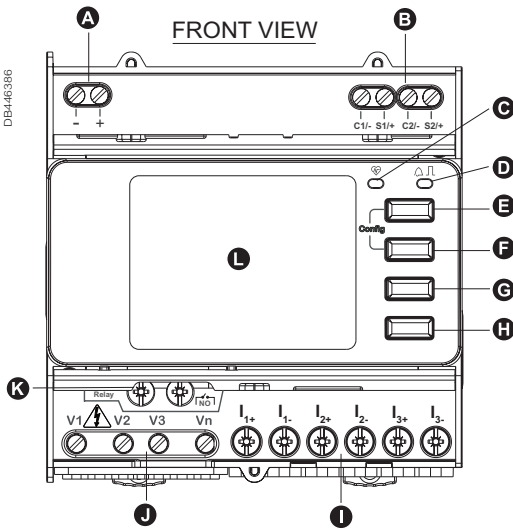

- Ⓐ Control power input 24 Vdc (-,+)
- Ⓑ Status inputs (C1/-, S1/+, C2/-, S2/+)
- Ⓒ Operation LED (Green)
- Ⓓ Alarm / Energy pulse LED (Orange)
- Ⓔ Cancellation button
- Ⓕ Confirmation button
- Ⓖ Up button
- Ⓗ Down button
- Ⓘ Current inputs (I_{1+} , I_{1-} , I_{2+} , I_{2-} , I_{3+} , I_{3-})
- ⓵ Voltage inputs (V1, V2, V3, Vn)
- Ⓚ Relay output (NO (r^{-}))
- Ⓛ Display with white backlight
- Ⓜ Ethernet port link/Activity LED (Green)
- Ⓝ Ethernet port Speed LED (Green)
(100 Mbps=Green / 10 Mbps=Off)
- Ⓞ Three sealing points
- Ⓟ Two sealable covers

TOP VIEW

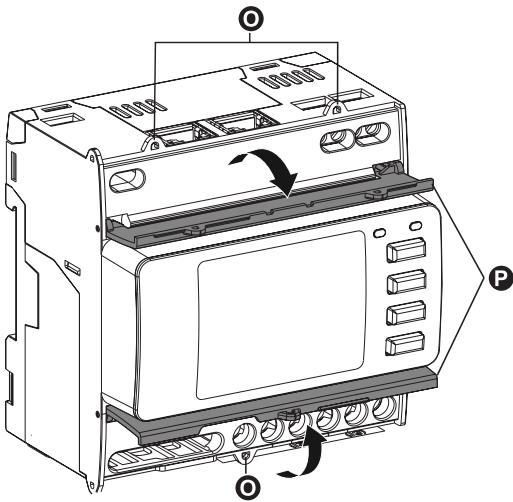
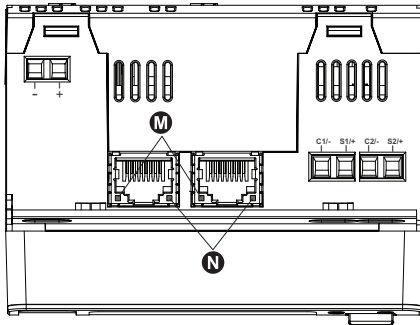



www.se.com

Schneider Electric Industries SAS
35, Rue Joseph Monier
CS 30323
92506 Rueil Malmaison Cedex

RCS Nanterre 954 503 439
Capital social 928 298 512 €
www.se.com

January 2026
PowerLogic™ EM3570 series
PLSED310190EN

As standards, specifications and designs develop from time to time, please ask for confirmation of the information given in this document.

© 2026 - Schneider Electric. All rights reserved.
All trademarks are owned by Schneider Electric Industries SAS or its affiliated companies.