

PowerLogic™ ION9000 series Technical Datasheet

The PowerLogic™ ION9000 is your 24/7 power quality expert, providing information, not just data.

With a comprehensive, industry-leading Power Quality Instrument (PQI) performance designation according to IEC 62586-1/-2, the PowerLogic™ ION9000 is third-party certified ANSI C12.20 Class 0.1 and IEC 62053-22 Class 0.1S accurate, the most accurate power meter available today. Lab-verified power quality and safety ensure reliable, precision performance that is perfect for supply- or demand-side applications. Its patented Disturbance Direction Detection also helps you pinpoint the source of power quality issues faster. Capable of sampling at 10 MHz, the ION9000T captures extremely fast voltage events that are missed by most other power meters, enabling advanced diagnostics and high-resolution event associations for fast, conclusive diagnosis and resolution to transient voltages.

Highly customizable and modular, the ION9000's field programmability can adapt to satisfy any solution, protecting your investment now and in the future. All designed to align with your comprehensive grid cybersecurity policies and backed by Schneider Electric's global services and support.

Applications

Ideal for critical power and large energy users who cannot afford to be shut down, the ION9000T has High-Speed Transient Capture (HSTC) to detect and record transient events that exceed the voltage withstand of sensitive equipment.

PB115917



METSEION92040

ION9000 series

The market solution for

Markets that benefit from a solution that includes PowerLogic™ ION9000 series meters:

- Data centers
- Healthcare facilities
- Semiconductor
- Pharmaceutical & chemical
- Energy industries
- Mining, Minerals, & Metals
- Renewable energy interconnects
- Medium voltage distribution & energy automation

Benefits

- Makes understanding power quality simple which helps operations personnel avoid downtime and increase productivity and equipment life
- Makes energy and power quality data immediately actionable and relevant to operational and sustainability goals

Competitive advantages

- Modular, flexible, patented ION™ programmable technology
- Utility grade energy accuracy
- Patented Disturbance Direction Detection
- Third-party, lab-verified compliance to the latest PQ standards
- Onboard pass/fail PQ characterization and assessment according to EN50160 and IEEE519
- Cybersecurity event logging, Syslog protocol, HTTPS, SFTP, and full control of each communication port
- High-speed impulsive and oscillatory transient detection

Power management solutions

Schneider Electric provides innovative power management solutions to increase your energy efficiency and cost savings. Maximize electrical network reliability and availability, and optimize electrical asset performance.

Conformity of standards

- | | |
|------------------|----------------|
| • ANSI C12.20 | • IEC 61850 |
| • ANSI C37.90.1 | • IEC 62052-11 |
| • IEC 61000-4-7 | • IEC 62052-31 |
| • IEC 61000-4-15 | • IEC 62053-22 |
| • IEC 61000-4-30 | • IEC 62053-23 |
| • IEC 61010-1 | • IEC 62053-24 |
| • IEC 61326-1 | • IEC 62586 |
| • IEC 61557-12 | • UL 61010-1 |



PowerLogic™ ION9000 front view

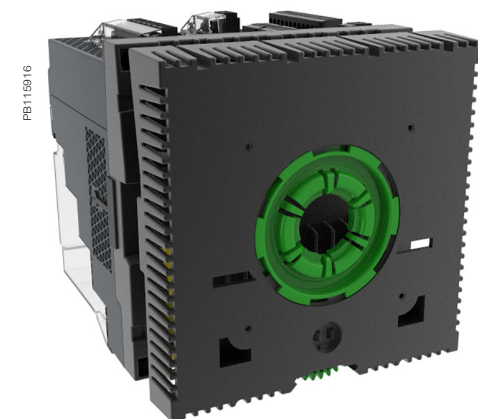

PowerLogic™ ION9000 with panel mounting adapter

ION9000 series



PowerLogic™ ION9000 series meter with RD192 display



PowerLogic™ ION9000 RD192 remote display



PowerLogic™ ION9000 Harmonics display

Main characteristics

- PQ compliance reporting and advanced PQ analysis:
 - Recognized as a Power Quality Instrument Class A to IEC62586-1 and IEC62586-2
 - Monitors and logs parameters according to IEC 61000-4-30 Class A international PQ standards (test methods as per IEC 62586-2).
 - High resolution waveform capture: triggered manually or by event. Captured waveforms available directly from the meter via SFTP in a COMTRADE format, and viewable in the meter's web interface.
 - Generates onboard PQ compliance reports accessible via onboard web pages:
 - Pass/fail report for IEEE 519 for voltage and current harmonic limits.
 - ITIC (CBEMA) and SEMI curves, with alarm categorization to support further analyses.
 - NEMA Motor Derating curve.
 - Harmonic analysis:
 - THD and TDD per phase, min/max, custom alarming.
 - Individual harmonic magnitudes and angles on voltage and current, up to the 63rd harmonic.
 - Disturbance detection and capture: sag/swell on any current and voltage channel, alarm on disturbance event, and waveform capture.
 - Patented Disturbance Direction Detection: provides indication of the captured disturbance occurring upstream or downstream of the meter; timestamped results provided in the event log, with degree of certainty of disturbance direction.
 - Monitor and detect subsynchronous oscillations to identify potentially harmful mechanical resonance or system instability.
 - Transient detection and capture: events 20 microseconds or longer in duration on any voltage channel with alarm, event log, and waveform capture.
 - PowerLogic™ ION9000T also provides High-Speed Transient Capture (HSTC) of voltage events 100 nanoseconds or longer in duration and up to 10,000 V in magnitude with high-speed and disturbance waveform captures, as well as per-event statistics on each transient.
- Metering precision:
 - IEC 61557-12 PMD/SD/K70/0.2 and PMD/SS/K70/0.2 3000m (Performance Measuring and Monitoring devices (PMD)).
 - Industry leading Class 0.1S accuracy IEC 62052-11 ed.2, ANSI C12.20 Class 0.1 (active energy).
 - Class 0.5S accuracy for reactive energy (IEC 62053-24).
 - Cycle-by-cycle RMS measurements updated every ½ cycle.
 - Full 'multi-utility' WAGES metering support.
 - Net metering.
 - Anti-tamper protection seals and hardware metrology lock.
- Cybersecurity:
 - Security events logging with Syslog protocol support.
 - HTTPS and SFTP secure protocols.
 - Ability to enable or disable any communication port and any protocol per port.
 - Anti-tamper protection seals and hardware metrology lock.
 - User accounts with strong passwords.
- Used with Schneider Electric's advanced software tools, provides detailed PQ reporting across entire network:
 - EN 50160 compliance report.
 - IEEE 519 harmonic compliance report.
 - IEC 61000-4-30 report.
 - Power quality compliance summary.
 - Energy reports for consumption analysis and cost management.
 - WAGES dashboards and reports.
 - Display of waveforms and PQ data from all connected meters.
 - Onboard web-based waveform viewer.

ION9000 series



PowerLogic™ ION9000 front with two option modules

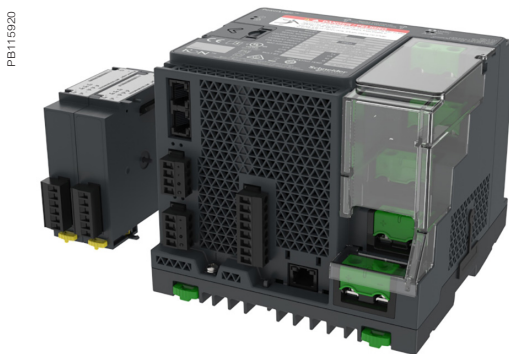

PowerLogic™ ION9000 bottom with two option modules



PowerLogic™ ION9000 iso with two communication option modules

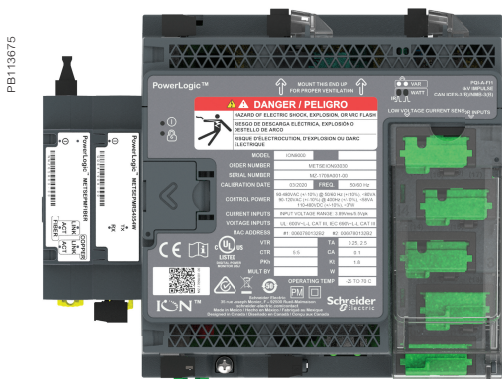

PowerLogic™ ION9000 with two communication option modules

sequence of events, and root cause analysis.

- Data and event logging:
 - Onboard data and event logging.
 - 2 GB of standard non-volatile memory.
 - No data gaps due to network outages or server downtime.
 - Min/max log for standard values.
 - 100 user-definable data logs, recording up to 50 parameters at a 1/2 cycle or other user definable interval.
 - Continuous logging or snapshot, triggered by setpoint and stopped after defined duration.
 - Trend energy, demand and other measured parameters.
 - Forecasting via web pages: average, minimum and maximum for the next four hours and next four days.
 - Advanced time-of-use capability.
 - Security/event log: alarm conditions, metering configuration changes, power outages, firmware download, and user login/logout with timestamp.
- Alarming and control:
 - 50+ definable alarms to log critical event data, trigger waveform recording, or perform control function.
 - Trigger on any condition, with 1/2-cycle and 1-second response time.
 - Combine alarms using Boolean logic enabling customization of alarms.
 - Alarm notification via email.
 - In conjunction with Schneider Electric's EcoStruxure™ software, alarms, software alarms, and alarm frequency are categorized and trended enabling sequence of events and root cause analyses.

Usability

- Auto-discovery using DPWS (Device Profile Web Services).
- DHCP for automatic IP address configuration.
- Full function web server enables simple web commissioning.
- Free setup wizard simplifies meter configuration.
- Front panel:
 - Easy to read color graphic display.
 - Simple and intuitive menu navigation with multiple language interface and support.
- DIN rail mounting options.
- Remote display option.
- Pluggable connectors.
- Low Voltage Current Sensors Input option.
- Flexible remote communications:
 - Multiple simultaneously operating communication ports and protocols allow interfacing with other automation systems, e.g. waveforms, alarms, billing data, etc. Data can be uploaded for viewing/analysis while other systems access real-time information.
 - Supports: BACnet/IP, Modbus, ION, DNP3, DLMS/COSEM, SNMP, and IEC 61850.
 - Supports MQTT Protocol for sharing up-to 30 customizable parameters of gap-less, high-speed power monitoring data.
 - Dual port Ethernet: 2x 10/100BASE-TX; supports IPV4 and IPV6; daisy-chaining capability removes need for additional switches.
 - Create redundant network loop using Rapid Spanning Tree Protocol (RSTP) and managed Ethernet switches.
 - Secure web interface with HTTPS and TLS 1.2 with support for user-provided certificates to access real-time power monitoring data, PQ compliance data, and customizable webpages.
 - Customize TCP/IP port numbers and enable/disable individual ports.
 - RS-485 2-wire connection, up to 115,200 baud, Modbus RTU, ION and DNP3 protocols.
 - Ethernet to serial gateway with Modbus Master functionality, connecting to 31 unit loads of downstream serial Modbus devices. Also supports Modbus Mastering over TCP/IP (Ethernet) network.

ION9000 series

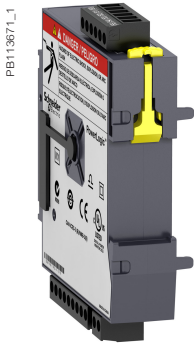

PowerLogic™ I/O module

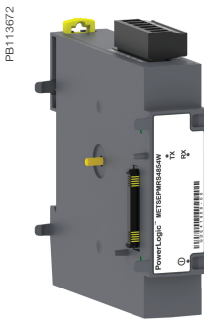

4-Wire RS-485 Option Module

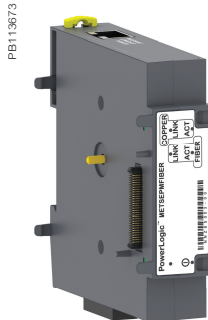

Fiber-Ethernet Option Module

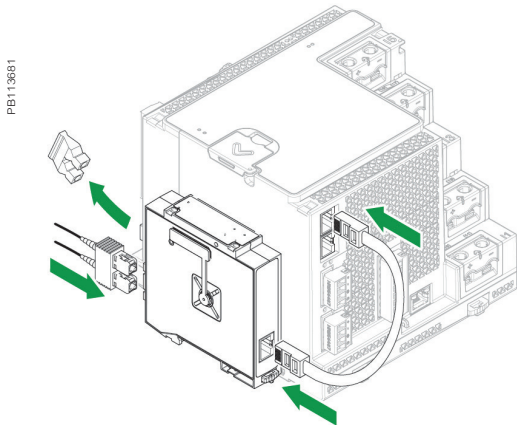

PowerLogic™ ION9000 connected with Fiber-Ethernet

- Time synchronization via:
 - Precision network time protocol (PTP) based on IEEE 1588 / IEC 61588.
 - GPS clock (RS-485) or IRIG-B (digital input) to ±1 millisecond.
 - Network Time Protocol (NTP/SNTP).
 - Automatic time synchronization available through Schneider Electric software server.

Adaptability

- ION™ frameworks are customizable, scalable applications with object-oriented programming that compartmentalizes functions, and increases flexibility and adaptability.
- Applications include: accessing and aggregating data from downstream Modbus devices over serial or across the network (Modbus TCP/IP), logging and/or processing data through totalization, unit conversion or other calculations, applying complex logic for alarming or control operations, and visualization via webpages.

Standard meter I/O

- 8 digital status/counter inputs with ±1 millisecond timestamp.
- 4 solid state digital outputs (Form A) for energy pulsing, interfacing with other systems or control.
- 2 Form C relay outputs for control applications.

Advanced Metering Option Modules

- Expanding meter's flexibility with communication and I/O option modules
- Powered from meter base

I/O Expansion Option Modules

Option modules include:

- Digital module:
 - 6 digital status/counter inputs.
 - 2 Form C relay outputs, 250 Vac, 8 A.
- Analog module:
 - 4 analog inputs (0...20 mA, 4...20 mA; 0...30 V).
 - 2 analog outputs (0...20 mA, 4...20 mA; 0...10 V) for interfacing with building management sensors and systems.

Communication Option Modules

Option modules include:

- 4-Wire RS-485 Module ⁽⁺¹⁾:
 - It adds 4-wire support to the meter i.e. eliminating the cost and efforts of rewiring while replacing/retrofitting legacy 4-Wire RS-485 systems
 - Pluggable screw terminal connector
- Fiber-Ethernet Module ⁽⁺²⁾:
 - Provides isolated data transmission through fiber optics up to 2000 m length
 - Supports multi-mode 100Base-FX type
 - SC duplex connector

⁽⁺¹⁾ One of the onboard 2-Wire RS-485 port is disabled with the optional module

⁽⁺²⁾ Connected to the meter base using Ethernet patch cable (included with the module)

Maximum of 4 optional modules in total (Fiber-Ethernet, 4-Wires RS-485, I/O modules) can be connected to the meter. Only 1 Fiber-Ethernet and 1 4-Wire RS-485 option module is supported per meter.

Please refer to the option module Installation Guides for more details.

ION9000 series

Feature guide

General	ION9000	ION9000T
Use on LV, MV, and HV systems	■	■
Current accuracy: 0.1 % reading	■	■
Voltage accuracy: 0.1 % reading	■	■
Active energy accuracy: 0.1 Class	■	■
Number of samples/cycle or sample frequency: 1024	■	■
High-Speed Transient Capture: 10 MHz (200 k for 50 Hz, 167 k for 60 Hz)	-	■
Instantaneous rms values		
Current, voltage, frequency	■	■
Active, reactive, apparent power: Total and per phase	■	■
Power factor: Total and per phase	■	■
Energy values		
Active, reactive, apparent energy	■	■
Settable accumulation modes	■	■
Demand values		
Current: Present and max. values	■	■
Active, reactive, apparent power: Present and max. values	■	■
Predicted active, reactive, apparent power	■	■
Synchronization of the measurement window	■	■
Setting of calculation mode: Block, sliding	■	■
Power Quality measurements		
Harmonic distortion: Current and voltage	■	■
Individual harmonics: via front panel and web page: 63 via EcoStruxure™ software: 511	■	■
Waveform capture	■	■
Detection of voltage swells and sags	■	■
Fast acquisition: 1/2 cycle data	■	■
EN 50160 compliance checking	■	■
Customizable data outputs (using logic and math functions)	■	■
IEEE 519 compliance checking	■	■
Subsynchronous oscillation detection and measurement	■	■
Data recording		
Min/max of instantaneous values	■	■
Data logs	■	■
Event logs	■	■
Trending/forecasting	■	■
SER (Sequence of event recording)	■	■
Time stamping	■	■
GPS synchronization (± 1ms)	■	■
Memory: 2000 MB	■	■
Display and I/O		
Front panel display, 2 options: 96 mm & 192 mm	■	■
Pulse output: 2	■	■
Digital or analog inputs(max): 32 digital, 16 analog	■	■
Digital or analog outputs (max, including pulse output): 4 digital, 10 relay, 8 analog	■	■
Communication		
2-Wire RS-485 port	■	■
Ethernet port(s): 2x 10/100BASE-TX, MQTT, RJ45 connector, CAT5/5e/6/6a cable	■	■
Serial port protocols (Modbus, ION, DNP3, DLMS/COSEM)	■	■
Ethernet port protocols (BACnet/IP, Modbus, ION, DNP3, DLMS/COSEM and IEC 61850)	■	■
Ethernet gateway	■	■
Alarm notification via email	■	■
HTTP/HTTPS web server with waveform viewer	■	■
SNMP with custom MIB and traps for alarms	■	■
SMTP email	■	■
PTP and NTP time synchronization	■	■
SFTP file transfer	■	■
Option module with 4-Wire RS-485 port	■	■
Option module with Fiber-Ethernet port	■	■

ION9000 series

Technical specifications

Electrical characteristics			ION9000	ION9000T
Type of measurement	True rms to 1,024 samples per cycle		■	■
	High-speed transient detection, 10 MHz, 10 kV		-	■
Measurement accuracy	Current & voltage	Class 0.1 as per IEC 61557-12	■	■
	Active Power	Class 0.1 as per IEC 61557-12	■	■
	Power factor	Class 0.5 as per IEC 61557-12	■	■
	Frequency	Class 0.02 as per IEC 61557-12	■	■
	Active energy	Class 0.1S IEC 62053-22 Class 0.1 IEC 61557-12 Class 0.1 ANSI C12.20	■	■
	Reactive Energy	Class 0.5S IEC 62053-24	■	■
Display refresh rate	HMI display updated once per second; data refresh rate 1/2 cycle or 1 second		■	■
Input-voltage characteristics	Specified accuracy voltage	57...400 V L-N / 100...690 V L-L	■	■
	Impedance	5 MΩ per phase	■	■
	Specified accuracy frequency	42...69 Hz (50/60 Hz nominal)	■	■
	Limit range of operation - frequency	20...450 Hz	■	■
Input-current characteristics	Rated nominal current	1 A (0.1S), 5 A (0.1S); current class 2, 10, 20 A (0.1 ANSI)	■	■
	Specified accuracy current range	Starting Current: 1 mA (no accuracy) Accurate Range: 10 mA...20 A	■	■
	Permissible overload	500 A rms for 1.0s	■	■
	Impedance	0.0003 Ω per phase	■	■
	Burden	0.01 VA max at 5 A	■	■
LV Input-current characteristics	Input voltage range	±5.5 V pk	■ ⁽⁺³⁾	-
	Minimum signal	1 mV	■ ⁽⁺³⁾	-
	Withstand	30 V pk continuous	■ ⁽⁺³⁾	-
	Input impedance	200 k Ω	■ ⁽⁺³⁾	-
	Safety	For use with listed Energy Monitoring current transformers	■ ⁽⁺³⁾	-
Power supply AC/DC	AC	90...480 Vac ±10 % (50/60 Hz ±10 %) 90...120 Vac ±10% (400 Hz)	■	■
	DC	110...480 Vdc ±10 %	■	■
	Ride-through time (Values for meters with no optional accessories)	100 ms (5 cycles at 50/60 Hz) typ., 120 Vac 400 ms (20 cycles at 50/60 Hz) typ., 240 Vac 1,200 ms (60 cycles at 50/60 Hz) typ., 480 Vac	■	■
	Burden	Typical: 16.5 W / 38 VA at 480 V (50/60 Hz) Fully optioned: max. 40 W / 80 VA at 480 V (50/60 Hz).	■	■
Power supply LVdc	DC	20 to 60 Vdc ±10 %	■	-
	Burden	Typical: 15 W at 20...60 Vdc Fully optioned: 38 W at 20...60 Vdc	■	-
Input/outputs	Meter base Only	8 digital inputs (30 Vac/60 Vdc) 4 Form A (KY) solid state digital output (30 Vac/60 Vdc, 75 mA) 2 Form C relays (8 A at 250 Vac, 5 A at 24 Vdc)	■	■
	Optional	Digital - 6 digital inputs (30 Vac / 60 Vdc) wetted + 2 Form C relay outputs (250 Vac, 8 A)	■	■
		Analog - 4 analog inputs (0...20 mA, 4...20 mA, 0...30 Vdc) + 2 analog outputs (0...20 mA, 4...20 mA, 0...10 Vdc).	■	■

⁽⁺³⁾ The LV Input-current option replaces standard CT inputs

ION9000 series

Mechanical characteristics		ION9000	ION9000T
Weight	DIN rail mount meter 1.5 kg IO modules 0.140 kg Touchscreen display 0.300 kg	■	■
IP degree of protection	IP 65, UL type 12: Panel mount and touchscreen display, front. IP 30: Panel mount rear, DIN rail mount, I/O modules.	■	■
Excellent quality	ISO 9001 and ISO 14000 certified manufacturing.	■	■
Dimensions	Panel mount	160 x 160 x 135.3 mm	■
	DIN rail mount meter	160 x 160 x 135.3 mm	■
	Color remote display (2 options)	197 x 175 x 27.5 mm touchscreen	■
	I/O modules	90.5 x 90.5 x 22 mm	■
	Touchscreen display(s)	192 mm and 96 mm	■
Environmental conditions			
Operating temperature	-25...70 °C	■	■
Remote Display Unit	-25...60 °C	■	■
Storage temperature	-40...85 °C	■	■
Humidity rating	5...95 % non-condensing	■	■
Installation category	III	■	■
Operating altitude (maximum)	3,000 m above sea-level	■	■
Electromagnetic compatibility			
EMC standards	IEC 62052-11, IEC 61326-1, IEC 61000-6-5	■	■
Immunity to electrostatic discharge	IEC 61000-4-2	■	■
Immunity to radiated fields	IEC 61000-4-3	■	■
Immunity to fast transients	IEC 61000-4-4	■	■
Immunity to surges	IEC 61000-4-5	■	■
Immunity to conducted disturbances	IEC 61000-4-6	■	■
Immunity to power frequency magnetic fields	IEC 61000-4-8	■	■
Immunity to conducted disturbances, 2-150kHz	CLC/TR 50579	■	■
Immunity to voltage dips & interruptions	IEC 61000-4-11	■	■
Immunity to ring waves	IEC 61000-4-12	■	■
Conducted and radiated emissions	EN 55011 and EN 55032 Class B, FCC part 15 Class B, ICES-003 Class B	■	■
Surge withstand Capability (SWC)	IEEE/ANSI C37.90.1	■	■
Safety			
Safety Construction	IEC/EN 61010-1 ed.3, CAT III, 400 V L-N / 690 V L-L, UL 61010-1 ed.3 and CSA-C22.2 No 61010-1 ed.3, CAT III, 347 V L-N / 600 V L-L, IEC/EN 62052-31, protective class II	■	■
Communication			
Ethernet to serial line gateway	Communicates directly with up to 31 serial devices	■	■
Web server	Customizable pages, new page creation capabilities, HTML/XML compatible	■	■
Serial port RS-485	2x, Baud rates of 2,400 to 115,200, pluggable screw terminal connector	■	■
Ethernet port(s)	2x 10/100BASE-TX, RJ45 connector, CAT5/5e/6/6a cable	■	■
Protocol	HTTPS, SFTP, SNMP, SMTR, DPWS, RSTR, PTR, NTP/SNTP, GPS, Syslog, DHCR, IPv4, IPv6, BACnet/IP, MQTT	■	■
Communication option module			
Optional port 4-Wire RS-485	Baud rates of 2400 to 115200, pluggable screw terminal connector	■	■
Optional Fiber-Ethernet port	Ethernet patch cable from base meter, multi-mode 100Base-FX, SC duplex connector	■	■

ION9000 series

Firmware characteristics		ION9000	ION9000T
High-speed data recording	Down to 1/2 cycle interval recording, stores detailed characteristics of disturbances or outages. Trigger recording by a user-defined setpoint, or from external equipment	■	■
Harmonic distortion	Up to 63rd harmonic (511th via Schneider Electric EcoStruxure™ software) for all voltage and current inputs	■	■
Sag/swell detection	Analyze severity/potential impact of sags and swells: magnitude and duration data suitable for plotting on voltage tolerance curves per phase triggers for waveform recording	■	■
Disturbance direction detection	Determine the location of a disturbance more quickly and accurately by determining the direction of the disturbance relative to the meter. Results are captured in the event log, along with a timestamp and confidence level indicating level of certainty	■	■
Detection & capture of transients	As short as 20 μs at 50 Hz (17 μs at 60 Hz)	■	■
High-speed transient capture	Detection and capture of high-speed impulsive and oscillatory transients as short as 100 ns in duration and up to 10 kV in magnitude	-	■
Instantaneous	High accuracy of standard speed (1s) and high-speed (1/2 cycle) measurements, including true rms per phase and total for: voltage, current, active power (kW), reactive power (kvar), apparent power (kVA), power factor, frequency, voltage and current unbalance, phase reversal	■	■
Subsynchronous oscillation detection and measurement	Analysis of the full subsynchronous spectrum (0–50 Hz), with detection of top ten peak magnitudes and the associated peak frequencies. Supports user defined frequency groups for which the module will report each frequency group's RMS magnitude.	■	■
Load profiling	Channel assignments (5000 channels via 100 recorders) configurable for any measurable parameter, including historical trend recording of energy, demand, voltage, current, power quality, or any measured parameter. Trigger recorders based on time interval, calendar schedule, alarm/event condition, or manually	■	■
Trend curves	Historical trends and future forecasts to better manage demand, circuit loading, and other parameters. Provides average, min, max, and standard deviation every hour for last 24 hours, every day for last month, every week for last 8 weeks and every month for last 12 months	■	■
Waveform captures	Simultaneous capture of voltage and current channels, sub-cycle disturbance captures of 180-cycles @ 1,024 samples/cycle to 7,200-cycles @ 16 sample/cycle, retriggerable	■	■
High-speed transient waveform captures	Simultaneous capture of voltage channels, impulsive and oscillatory transient capture of up to 1-cycle @ 200 k samples per cycle (50 Hz) along with coincidence disturbance waveform capture	-	■
Alarms	Threshold alarms: adjustable pickup and dropout setpoints and time delays, numerous activation levels possible for a given type of alarm, user-defined or automatic alarm threshold settings, user-defined priority levels (optional automatic alarm setting)	■	■
Advanced Time of Use (TOU)	4 seasons; 5 different day types: weekend, weekday, and holiday; up to 4 tariffs per day type	■	■
Advanced network security	Up to 50 users with unique access rights. Perform resets, time sync, or meter configurations based on user privileges	■	■
Memory	2,000 MB	■	■
Firmware update	Update via the communication ports	■	■
Display characteristics			
96 mm pushbutton display	320 x 240 (1/4 VGA) color LCD, configurable screens, 5 buttons and 2 LED indicators (alarm and meter status)	■	■
192 mm touchscreen display	800 x 480 pixels, 177.8 mm (7") Color LCD, +/- 85 degree view angle, sunlight readable, dual capacitive touch, usable when wet or through Class 0 lineman gloves, impact resistant to 5 joules, IP65 rating	■	■
Languages	English, French, Spanish, Russian, Portugese, German, Italian, Chinese	■	■
Notations	IEC, IEEE	■	■

ION9000 series

ION9000 Commercial reference numbers

Comm ref number	Description
METSEION92030	ION9000 meter, DIN mount, no display, hardware kit
METSEION92040	ION9000 meter, DIN mount, 192 mm display, B2B adapter, hardware kit
METSEION92043	ION9000 meter, DIN mount, 192 mm display, B2B adapter, hardware kit, Measurement Canada Ready (Canada only)
METSEION92044	ION9000 meter, DIN mount, 192 mm display, B2B adapter, hardware kit, Measurement Canada Sealed (Canada only)
METSEION92130	ION9000 Meter, 20-60 Vdc control input, DIN mount, no display, hardware kit
METSEION92140	ION9000 Meter, 20-60 Vdc control input, DIN mount, 192 mm display, B2B adapter, hardware kit
METSEION93030	ION9000 meter, LVCS, DIN mount, no display, hardware kit
METSEION93040	ION9000 meter, LVCS, DIN mount, 192 mm display, B2B adapter, hardware kit
METSEION93130	ION9000 Meter, LVCS, 20-60 Vdc control power, DIN mount, no display, hardware kit
METSEION93140	ION9000 Meter, LVCS, 20-60 Vdc control power, DIN mount, 192 mm display, B2B adapter, hardware kit
METSEION95030	ION9000T meter, HSTC, DIN mount, no display, hardware kit
METSEION95040	ION9000T meter, HSTC, DIN mount, 192 mm display, B2B adapter, hardware kit
METSERD192	Remote display, color touchscreen, 192 x 192 mm
METSEPM89RD96	Remote display, color LCD, 96 x 96 mm
METSEPM89M2600	I/O module, 2 relay outputs, 6 digital inputs
METSEPM89M0024	I/O module, 2 analog outputs, 4 analog inputs
METSE9HWK	ION9000 meter hardware kit – plugs, terminal guards, spare grounding screw, DIN clips
METSE9CTHWK	ION9000 Current Input hardware kit - terminal screws, CT covers
METSERD192HWK	RD192 remote display hardware kit
METSE9B2BMA	ION9000 B2B (back to back) mounting adapter
METSE9HWKLVCS	ION9000 hardware kit for LVCS
METSE9USBK	ION9000 USB cover hardware kit
METSE7X4MAK	ION7X50 mounting adapter kit
METSEPMRS4854W	4-Wire RS 485 option module
METSEPMFIBER	Fiber-Ethernet option module

Contact your Schneider Electric representative for complete ordering information.

ION9000 series

ION9000 meter dimensions

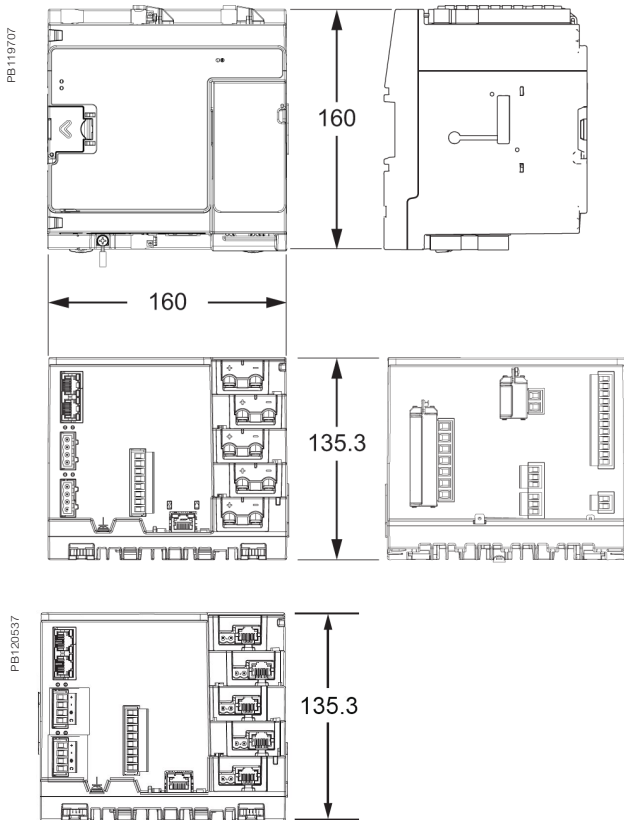

LVCS Input-current option

ION9000 mounting template

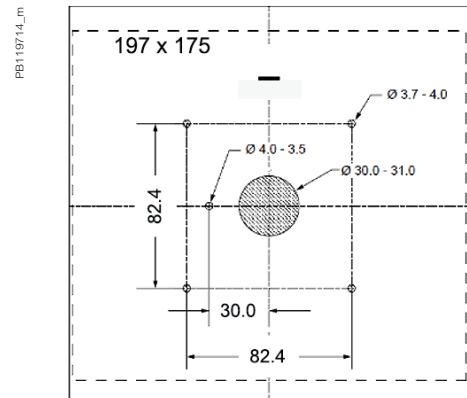

ION9000 back-to-back (B2B) dimensions

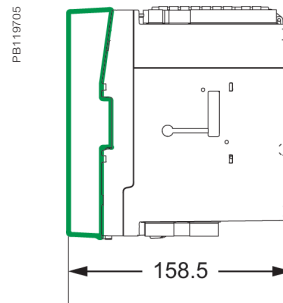

ION9000 192 mm display dimensions

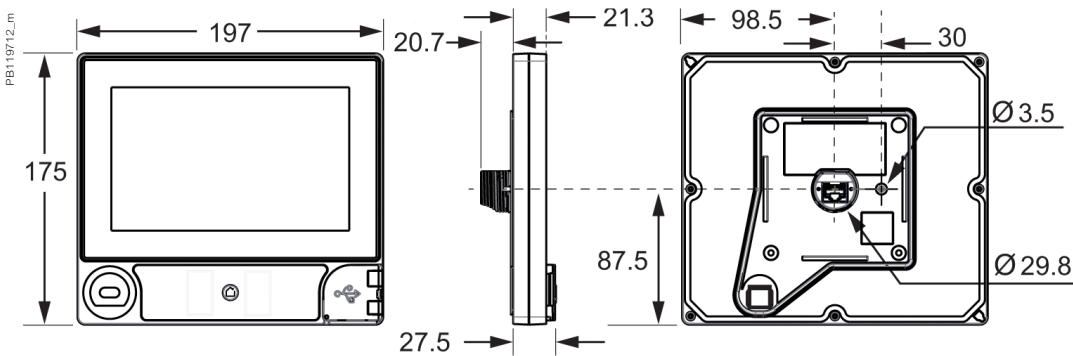

ION9000 96 mm display dimensions

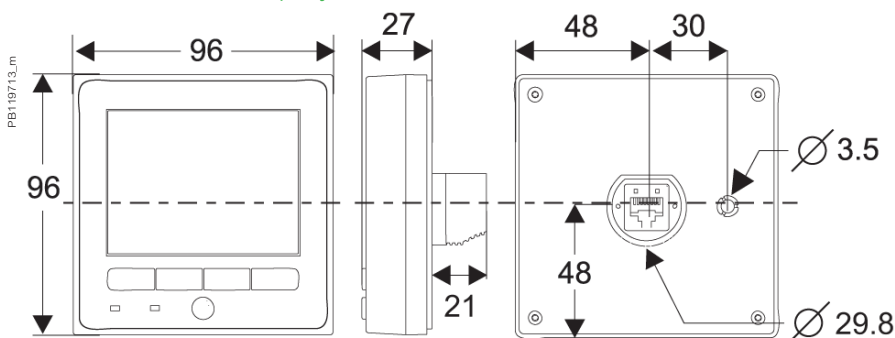

Please refer to ION9000 Series Meter Installation Sheet for accurate and complete information on the installation of this product.

ION9000 series

ION9000 meter DIN rail dimensions

ION7x50 mounting adapter dimensions

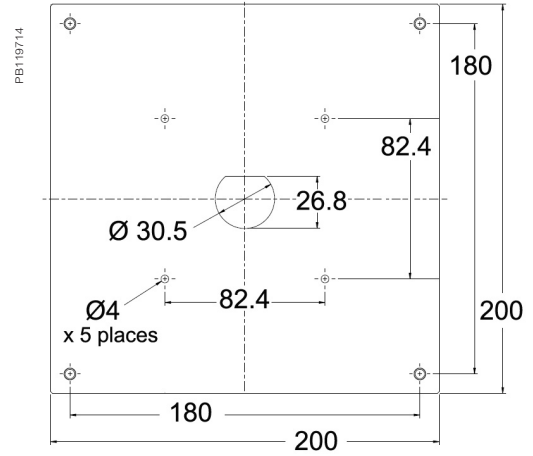
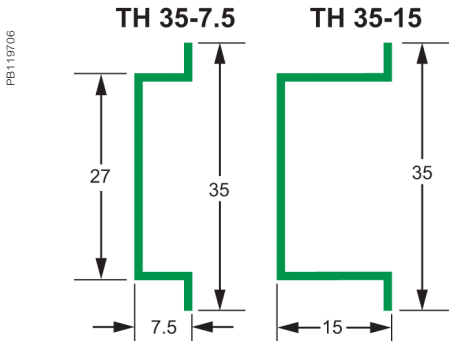

ION9000 LV Current Input wiring options

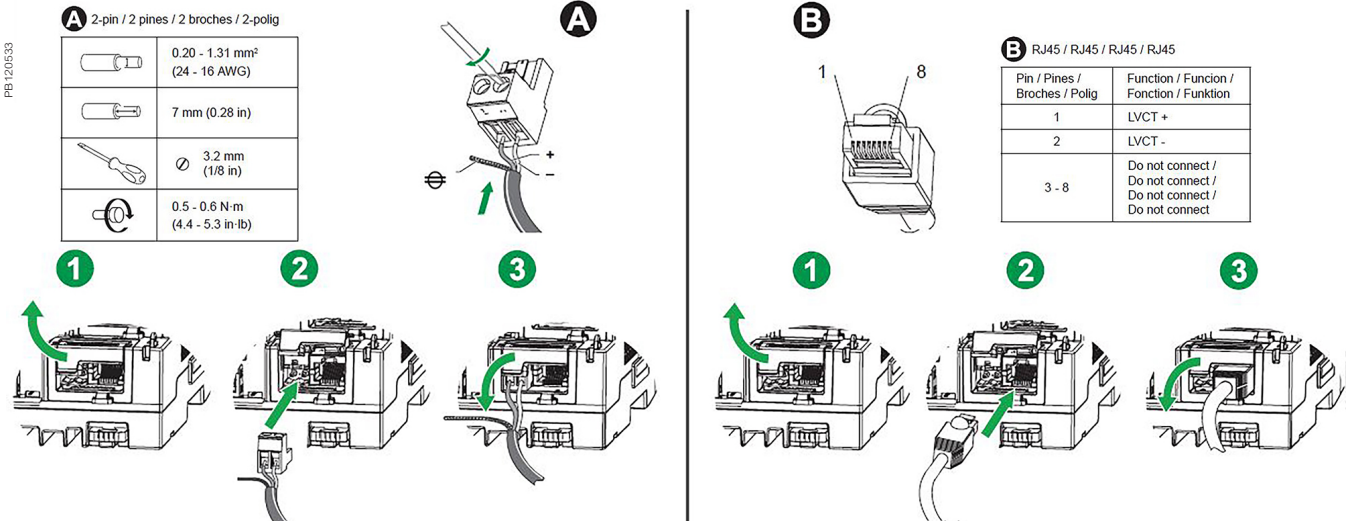

ION9000 with communication option modules

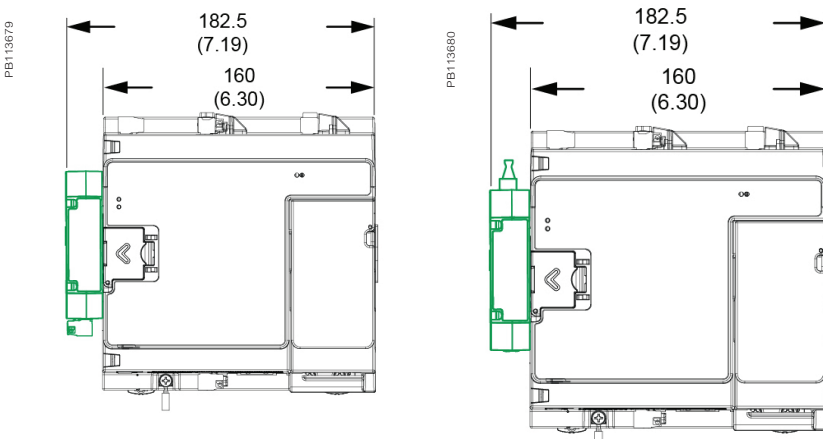



www.se.com

Schneider Electric Industries SAS
35, Rue Joseph Monier
CS 30323
92506 Rueil Malmaison Cedex
France

RCS Nanterre 954 503 439
Capital social 928 298 512 €
www.se.com

March 2026
PowerLogic™ ION9000 Series
PLSED310181EN

© 2026 - Schneider Electric. All rights reserved.
All trademarks are owned by Schneider Electric
Industries SAS or its affiliated companies.

As standards, specifications and designs develop from time to time, please
ask for confirmation of the information given in this document.