

EasyLogic™ Power Metering Range Catalog

Catalog 2026

A Complete Range Of Meters For
Essential Electrical System Measurement



www.se.com

Life Is On

Schneider
Electric

Contents

Panorama of the EasyLogic™ Range	3
PM2000 Series	6
Power and Energy Multi-function Meters	
PM2220R Quick Click Series	18
Power and Energy Multi-function Meters with Quick Click CTs	
EM1000H Series	27
Energy Meters	
PM1000H Series	33
Basic Power and Energy Meters	
PM1130H / PM1140M / PM1230H Series	40
Dual Source Power and Energy Meters	
DM1000 / DM3000 Series	47
Digital Panel Meters	
DM6xx0H Series	52
VAF PF Digital Panel Meters	
IP65 Accessory Kit	59
Accessories	
IP54 Gasket	63
Accessories	
Commercial Reference Numbers	66
See your Schneider Electric representative for complete ordering information	

Panorama of the EasyLogic™ Range



Family	PM2000	PM2220R	EM1000H
Parameters	PM2100 (LED)	PM2220R	EM1220H / EM1250H
Amps: per phase and 3-ph avg	■	■	■ / -
Volts: per phase and 3-ph avg	■	■	■ / -
Frequency	■	■	■ / -
Power Factor per phase and 3-ph avg	■	■	■
W per phase and 3-ph total, Wh	■	■	■
VAR per phase and 3-ph total, VARh	■	■	□ * / ■
VA per phase and 3-ph total, VAh	■	■	□ * / ■
Class of Accuracy*	1.0 active (0.5S PM2x30) 1.0 reactive	1.0 active 1.0 reactive	Active - CI 1.0, CI 0.5 / CI 1.0 Reactive - CI 2.0 / CI 2.0
2 DI / 2 DO or 2 DI / 2 RO (optional)	(PM2130)		
2 AI / 2 AO (optional)	(PM2130)		
RS-485 Modbus RTU	■	■	■
CT Secondary I nominal	5 A or 1 A	LVCT	5 A or 1 A
Control Power	48 - 277 V AC / DC ±10%**	48 - 277 V AC / DC ±10%**	48 - 277 V AC / DC ±10% or 9 - 36 V DC (option)
Form Factor in mm	96x96x54	96x96x54	96x96x49
With IO module	96x96x72	96x96x72	
Mounting	Flush/Panel	Flush/Panel	Flush/Panel
Simple energy cost management			
Data aggregation	■	■	■
Load profile	■	■	■
Bill verification	■	■	■
Cost allocation	■	■	■
Basic network management			
Panel instrumentation	■	■	■
Power metering	■	■	■
Basic harmonic monitoring	■	■	
Status monitoring	■	■	
Threshold alarming	■	■	
Monitoring and verification			
Test bench	■	■	■
Genset	■	■	■
PF Improvement panel	■	■	■
Labs / OEMs	■	■	■
Commercial reference numbers (Link to product information)	METSEPM2110 METSEPM2120 METSEPM2130	METSEPM2220R	METSEEM1220HCL10RS METSEEM1220HCL05RS METSEEM1250HCL1 METSEEM1220HCL1 METSEEM1220HCL5 METSEEM1220HCL5LVD

□* One power vector at a time (W/Wh or VA/VAh or VAR/VARh in EM1120H).

** 80 - 277 Vac ±10% for PM2x30.

Panorama of the EasyLogic™ Range



Family	PM1000H		PM1130H	PM1140H	PM1230H
Parameters	PM1120H / PM1125H	PM1225H	PM1130H (LED)	PM1140H (LED)	PM1230H (LCD)
Amps: per phase & 3-ph avg	■	■	■	■	■
Volts: per phase & 3-ph avg	■	■	■	■	■
Frequency	■	■	■	■	■
Power Factor per phase & 3-ph avg	■	■	■	■	■
W per phase & 3-ph total, Wh	□/■	■	■	■	■
VAR per phase & 3-ph tota, VARh	□/■	■	□	□	□
VA per phase & 3-ph total, VAh	□/■	■	□	□	□
Display type	LED	LCD	LED	LED	LCD
Class of Accuracy*	1.0 active (0.5 optional)	1.0 active (0.5 optional)	0.5 active	1.0 active (0.5 optional)	1.0 active (0.5 optional)
Control Power	48 - 277 Vac/dc ±10% or 9 - 36 Vdc (option)	48 - 277 Vac/dc ±10% or 9 - 36 Vdc (option)	60 - 277 Vac/dc ±10%	60 - 277 Vac/dc ±10%	60 - 277 Vac/dc ±10% or 9 - 36 Vdc (option)
RS-485 Modbus RTU	■	■	■	■	■
CT Secondary I nominal	5 A or 1 A	5 A or 1 A	5 A or 1 A	5 A or 1 A	5 A or 1 A
Form Factor in mm	96x96x49	96x96x49	96x96x52	96x96x52	96x96x52
Relay			1	1	1
Mounting	Flush/Panel	Flush/Panel	Flush/Panel	Flush/Panel	Flush/Panel
Simple energy cost management					
Data aggregation	■	■	■	■	■
Load profile	-	-	-	-	-
Bill verification	■	■	■	■	■
Cost allocation	■	■	■	■	■
Basic network management					
Panel instrumentation	■	■	■	■	■
Power metering	■	■	■	■	■
Basic harmonic monitoring	■	■	■	■	■
Status monitoring	-	-	-	-	-
Threshold alarming	-	-	■	■	■
Monitoring and verification					
Test bench	■	■	■	■	■
Genset	■	■	■	■	■
PF Improvement panel	■	■	■	■	■
Labs / OEMs	■	■	■	■	■
Commercial reference numbers (Link to product information)	METSEPM1120HCL10RS METSEPM1120HCL05RS METSEPM1125HCL10RS METSEPM1125HCL05RD METSEPM1125HCL1LVD METSEPM1125HCL5LVD	METSEPM1225HCL1 METSEPM1225HCL5 METSEPM1225HCL1LVD METSEPM1225HCL5LVD	METSEPM1130HCL05RS	METSEPM1140HCL1 METSEPM1140HCL1	METSEPM1230HCL1 METSEPM1230HCL5LVD METSEPM1230HCL5

* Refer data sheet for operating range

□ One power vector at a time (W/Wh or VA/VAh or VAR/VARh in PM1120H, PM1130H and PM1230H)

Panorama of the EasyLogic™ Range



Family	DM1000			DM3000		DM6xx0H	
Parameters	DM1110	DM1210	DM1310	DM3110	DM3210	DM6000H	DM62X0H
Amps: per phase & 3-ph avg	1-ph	-	-	3-ph (per ph)	-	■	■
Volts: per phase & 3-ph avg	-	1-ph	-	-	3-ph (per ph)	■	■
Frequency	-	-	■	-	-	■	■
Power Factor per phase & 3-ph avg	-	-	-	-	-	■	■
CT Secondary I nominal	5 A or 1 A	-	-	5 A or 1 A	-	5 A or 1 A	5 A or 1 A
Class of Accuracy	0.5	0.5	0.2	0.5	0.5	1	1
Control power	48 - 277 Vac/ dc±10%	48 - 277 Vac/dc ±10%	48 - 277 Vac/ dc±10%	48 - 277 Vac/dc ±10%	48 - 277 Vac/ dc±10%	48 - 277 Vac/dc ±10%	48 - 277 Vac/dc ±10% or 9 - 36 Vdc (option)
RS-485 Modbus RTU	-	-	-	-	-	-	■
Display type	LED	LED	LED	LED	LED	LED	LED (DM6200H) LCD (DM6220H)
Form Factor in mm (LengthxWidthxDepth)	96x96x44	96x96x44	96x96x44	96x96x44	96x96x44	96x96x49	96x96x49
Mounting	Flush/Panel	Flush/Panel	Flush/Panel	Flush/Panel	Flush/Panel	Flush/Panel	Flush/Panel

Simple energy cost management

Data aggregation	-	-	-	-	-	-	■
Load profile	-	-	-	-	-	-	-
Bill verification	-	-	-	-	-	-	-
Cost allocation	-	-	-	-	-	-	-

Basic network management

Panel instrumentation	■	■	■	■	■	■	■
Power metering	-	-	-	-	-	-	-
Basic harmonic monitoring	-	-	-	-	-	-	-
Status monitoring	-	-	-	-	-	-	-
Threshold alarming	-	-	-	-	-	-	-

Monitoring and verification

Test bench	■	■	■	■	■	■	■
Genset	■	■	■	■	■	■	■
PF Improvement panel	-	-	-	-	-	■	■
Labs / OEMs	■	■	■	■	■	■	■
Commercial reference numbers starts with METSE***	DM1110	DM1210	DM1310	DM3110	DM3210	DM6000HCL10NC	DM6200HCL10RS DM6220HCL1 DM6220HCL1LVD

EasyLogic™ PM2000 Series Technical Datasheet

The EasyLogic™ PM2000 multi-function power and energy meter

Offering all the measurement capabilities required to monitor and electrical installation in a single 96x96 mm unit, with LED or LCD display options.

Applications

Cost management applications

- Bill checking to verify that you are only charged for the energy you use
- Aggregation of energy consumption, including WAGES, and cost allocation per area, per usage, per shift or per time within the same facility
- Energy cost and usage analysis per zone, per usage or per time period to optimise energy usage

Network management applications

- Metering of electrical parameters to better understand the behaviour of your electrical distribution system
- Power quality analysis



LED display



LCD display

PM2000 Series

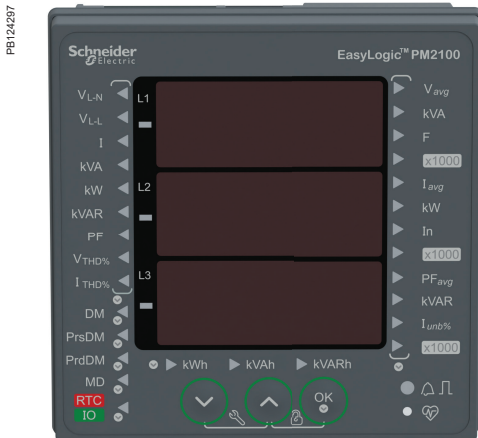

PM2100 series LED display meter



PM2200 series LCD display meter

Introducing EasyLogic PM2000 series, next generation power meter which offers all the measurement capabilities required to monitor an electrical installation in a single 96x96 mm unit. PM2000 meters are available in LED and LCD display variants.

- PM2100 series:
 - LED display type: Intuitive navigation with self-guided, three buttons, bright red colour LEDs of 14.2 mm height. Two columns of LEDs indicate the parameter name chosen for display.
- PM2200 series:
 - LCD display type: Monochrome graphical LCD of 128x128 pixels lets users read all three phase values simultaneously. The bright display enables easy reading even in extreme lighting conditions and viewing angles. with intuitive menus, multi-language text, icons and graphics.
- Network management:
 - Power Quality analysis: THD % and individual harmonics to 15th or 31st order.
 - Measurement of True PF and Displacement PF.
 - Recording Min/Max values of instantaneous parameters with date and timestamp.
 - Optional IO modules comprising either 2 Digital Inputs and 2 Outputs, or 2 Analog Inputs and 2 Outputs, or 2 Digital Inputs and 2 Relay Outputs for comprehensive WAGES monitoring.
 - Calculates % unbalance for voltage & current.
 - Embedded 2 D/I and 2 R/O or 2 A/I and 2 A/O in PM2125 and PM2225 meters.
- Main characteristics:
 - Easy to install: Mounts using two clips, no tools required. Compact 54 mm depth, connectable up to 480 ±10% AC Volts L-L without voltage transformers for installations compliant with measurement category III, and double insulated.
 - Easy to operate: Intuitive navigation with self-guided menus and LED for test and calibration on site or lab. Heartbeat LED indicates normal functioning and communication status if connected to RS-485 network.
 - Product standard compliance
 - Active energy Class 1.0 as per IEC 62053-21
 - Active energy Class 0.5S as per IEC 62053-22 (partial compliance for active energy test clause only)
 - Reactive energy Class 1.0 as per IEC 62053-23 (partial compliance for reactive energy test clause only)
 - Tested in accordance with IEC 62052-11 standard for
 - 5 A, I-nominal
 - 1 A, I-nominal (field settable).
 - Power quality analysis: The PM2000 offers THD % measurements and Individual harmonics up to 15th order in PM2x20 and PM2x25C variants and up to 31st in PM2x30 variants.
 - Load management: Simultaneous display of peak, present, predicted & rising demands of all the four demand parameters (W, VA, VAR, Amps)
 - Billing: Tenant billing/utility meter cross check (where local regulations are not applicable).
 - Timer: Active load timer, Meter operation timer and Run hours timer. These features help advise maintenance requirements and scheduling.

PM2000 Series



PB124299

Rear of PM2100 series - closed



PB124300

Rear of PM2100 series - open

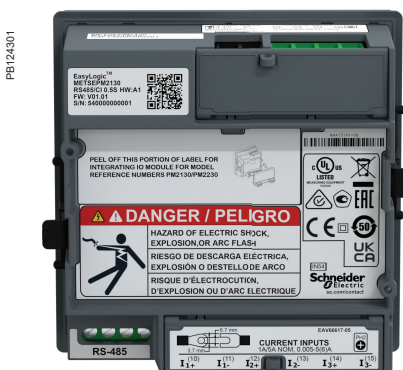

PB124301

Rear of PM2100 series without I/O module

- Main characteristics: (cont'd)
 - Password: Field configurable password for securing set up information and prevent tampering of integrated values.
 - Cyber security: Option for disabling RS-485 port through front panel keys against unauthorized access. It helps during installation and troubleshooting of communication network.
 - LED display: Auto scaling, 9+3 digits for energy, 4 digits for other parameters.
 - LCD display: 5 digits for energy, 5 or 6 digits for other parameters, with auto scaling.
 - Daily time snapshot: Snapshot of Avg Voltage, Avg Current, Total Active Power & Energy delivered as measured by the meter at configurable time of day. The static page will be refreshed with new values at a configured time next day.
 - Rate counters: 2 configurable counters display values in custom specified units based on energy recorded (e.g., kgCO₂ carbon emission or energy cost).
 - Energy preset feature: Write the energy values during maintenance operation or replacement of meters. Configuration is through ION set up utility tool.
 - Auto reset: Monthly reset of all energies and max demand based on configurable day of the month at fixed 00 Hours (PM2220, PM2230).
 - Suppression current: To disregard induced or negligible current flowing in the circuit, minimum value of current detection can be settable from 5 to 99 mA, default is 5 mA (all variants).
 - Retrofit register: Legacy modbus registers to read 50 parameters (meters with communication port).
 - Quadrant based VARh: Available through communication.
 - Multi-tariff energy - 4 multi tariff registers, can be activated through command, TOU or Input mode with Digital IO card (PM2230).
 - Non-resettable energy (Del & Rec values of Wh, VARh, VAh) counter on display and communication that cannot be reset to zero (PM2210/20/30).
 - Configurable favourite page: Pick and configure any 4 parameters for display from the list of - V L-L, V L-N, Amps, F, W-tot, VA-tot, VAR-tot, PF and Wh-Del, VAh-Del, VARh-Del (PM2220, PM2230).
 - Whetting output voltage: Can be used for excitation of status input signal, available in PM2K2DIRO module.
 - Auto correction of CT polarity: self-correction of CT polarity through setup mode to avoid shutdown/rewiring
 - Phase sequence reversal: self correction of phase sequence rotation through setup mode to eliminate the need of rewiring
 - Per phase energy: individual, per-phase energy measurement and display in 3 phase network.

PM2000 Series

Technical specifications

General	
Use on LV and MV systems with onsite programmable PT/CT ratio	
Basic metering with THD %, Individual Harmonics, RTC and min/max readings	
Instantaneous rms values	
Current	Average line current of 3-phase, per-phase, and calculated neutral current
Voltage	Average voltage of L-L, L-N parameters, and per-phase
Frequency	Any available line
Real, reactive, and apparent power	Total and per-phase value
Displacement power factor	Average and per-phase signed, four quadrant
True Power Factor	Average and per-phase signed, four quadrant
% Unbalance	Among the phase for Amps, V L-N, V L-L
Energy values stored in non-volatile memory	
Four quadrant measurement for Delivered (Forward or Import) and Received (Reverse or Export) energy	Accumulated energy values for Active, Reactive & Apparent Energy parameters, quadrant basis Net & Total (absolute) values
Timer	Accumulated time counters for active load timer, meter operation timer, run hours and power outage counter
Old Registers	Facilitates retrieval of last cleared energy values
Demand values	
Current average	Present, Last, Predicted, Peak, and Peak Date Time
Active power	Present, Last, Predicted, Peak, and Peak Date Time
Reactive power	Present, Last, Predicted, Peak, and Peak Date Time
Apparent power	Present, Last, Predicted, Peak, and Peak Date Time
Demand sync methods	Thermal, Timed, Command Sync, and Clocked Sync
Demand calculation mode	Sliding, fixed and rolling block
Demand intervals	Settable from 1 to 60 minutes, in steps of 1 minute
Display	
PM2100 series	Bright red colour LED display, 7 segment LED, ~ 14.2 mm height, 3 rows with 4 digits per row, Auto range
PM2200 series	Full scape, monochrome graphical LCD of 128 x 128 pixels with viewable area of 67x62.5 mm
Visualization mode for signs	IEC or IEEE type in LCD display meter
Communication	
RS-485 serial	Channel connection Industry standard Modbus RTU protocol
Integration with software	SCADA/DCS/PMS/EMS/BAS/BMS software
Native Plug and Play support	Schneider Electric energy management system software - EcoStruxure™ Power Monitoring Expert, EcoStruxure™ Power Operation, & ION Setup programming support
Min/Max values	
Minimum & Maximum value recording of 3-ph average or total	For 9 parameters, viz., V L-L, V L-N, Amps, PF, Hz, W, VA, VAR, calculated neutral current value with date and time stamp, resettable separately through set up mode
Alarms	
Alarming with time stamping in PM2x30 meters	A different combination of set point driven alarms and digital alarms with 1 s time stamping. The alarms can be programmed and combined to trigger digital outputs, the meter keeps an alarm logs with the active and historical alarms with date and time stamping in 40 registers
Diagnostics	
Diagnostic page	Indicates LED/LCD status, sl number, diag pages for communication, OS & RS version
Lock/ Un-Lock	
Page Lock & Unlock (PM2100 series)	Unique feature to ensures that commonly referred page is restored in 4 minutes of inactive time
Rate 1 counter ^(*)	
kgCO ₂ emission (example)	Rate counter can be configured to display the CO ₂ emission in kgCO ₂ format based on the kWh measured either in delivered or received direction.
Rate 2 counter ^(*)	
Tariff counter (example)	Rate counter can also be configured to calculate the electricity cost based on the energy consumption in customized currency format.
Configurable snapshot	
Configurable snapshot ^(*)	Snapshot of Avg Voltage, Avg Current, Total Active Power & Energy delivered as measured by the meter at configurable time in Hours:Minutes format. Static page is refreshed with new values by next day at pre-configured time

^(*) Available in PM2220/PM2230 (LCD) meters

PM2000 Series

Technical specifications (continued)

Electrical characteristics				
Type of measurement	True RMS 64 samples per cycle			
Measurement accuracy				
Parameters	PM2210/PM2220/PM2110/PM2120		PM2230/PM2130/PM2225C/PM2125C	
	Accuracy class as per IEC standards IEC 61557-12: PMD/[SDJSS]/K70/1	% error	Accuracy class as per IEC standards IEC 61557-12: PMD/[SDJSS]/K70/0.5	% error
Active (Wh) energy	Class 1 (Class 1 as per IEC 62053-21 at In = 5A nominal CT)	±1%	Class 0.5S (Class 0.5s as per IEC 62053-22 at In = 5A nominal CT)	±0.5%
Reactive (VARh) energy	Class 2 (Class 1 as per IEC 62053-23 at In = 5A nominal CT)	±1%	Class 2 (Class 1 as per IEC 62053-23 at In = 5A nominal CT)	±1%
Apparent (VAh) energy	Class 1 at In = 5A nominal CT	±1%	Class 0.5 at In = 5A nominal CT	±0.5%
Active power	Class 1	±1%	Class 0.5	±0.5%
Reactive power	Class 1	±1%	Class 1	±1%
Apparent power	Class 1	±1%	Class 0.5	±0.5%
Current	Class 1	±0.5%	Class 0.5	±0.2%
Voltage (L-L)	Class 1	±0.5%	Class 0.5	±0.2%
Voltage (L-N)	Class 1	±0.5%	Class 0.5	±0.2%
Frequency	Class 1	±0.05%	Class 0.05	±0.05%
Power factor	Class 1	±0.01 Count	Class 0.5	±0.01 Count
THD % and individual harmonics	Class 5	±5%	Class 5	±5%
Input-voltage				
VT primary	999 kV L-L max, secondary voltage depends on VT ratio			
U nominal	277 V L-N/480V L-L			
Measured V with full range	20-277 V L-N/35 - 480 V L-L, cat III 20-347 V L-N/35 - 600 V L-L, cat II			
Permanent overload	750 Vac L-L			
Impedance	=> 5 MΩ			
Frequency nominal	50/60 Hz			
VA burden	< 0.2 VA at 240 Vac L-N			
Input-current				
CT ratings	Primary adjustable 1 A to 32768 A Secondary 1 A or 5 A I-nominal field settable			
Measured Amps with over range and Crest Factor	5 mA to 6 A			
Over current withstand	Continuous 12 A, 10s/hr 50 A, 1s/hr 500 A			
Impedance	< 0.3 mΩ			
Frequency nominal	50/60 Hz			
VA Burden	<0.024 VA at 6 A			
AC control power				
Operating range	44- 277 Vac ±10% (80-277 Vac ±10% for PM2x30/PM2x25)			
Burden	<6 VA at 277 Vac L-N (<8 VA for PM2x30 and PM2x25)			
Frequency	45 to 65 Hz			
Ride-through time	100 ms typical at 120 V AC and maximum burden (50 ms with Analog IO card for PM2x30) 400 ms typical at 230 V AC and maximum burden (50 ms with Analog IO card for PM2x30)			
DC control power				
Operating range	48-277 Vdc ±10% (100-277 Vdc ±10% for PM2x30/PM2x25)			
Burden	< 2 W at 277 Vdc (< 3.3 W for PM2x30 and PM2x25)			
Ride-through time	50 ms typical at 125 Vdc and maximum burden			
Real time clock				
RTC with battery backup	3 years (when meter is in Power OFF condition)			
Displays update				
Instantaneous	1 s			
Demand	15 s			
Harmonics	5 s			
Wiring configuration				
User programmable	1ph, 2w, L-N 1ph, 2w, L-L 1ph, 3w, L-L with N (2phase) 3ph, 3w, Delta, Ungrounded 3ph, 3w, Delta, Corner Grounded ⁽⁺²⁾ 3ph, 3w, Wye, Ungrounded ⁽⁺²⁾ 3ph, 3w, Wye Grounded ⁽⁺²⁾ 3ph, 3w, Wye, Resistance Grounded ⁽⁺²⁾ 3ph, 4w, Open Delta, Center-Tapped ⁽⁺²⁾ 3ph, 4w, Delta, Center-Tapped ⁽⁺²⁾ 3ph, 4w, Wye, Ungrounded ⁽⁺²⁾ 3ph, 4w, Wye Grounded 3ph, 4w, Wye, Resistance Grounded ⁽⁺²⁾ 3ph, 3w, Wye Grounded ⁽⁺²⁾ 3ph, 3w, Wye, Resistance Grounded ⁽⁺²⁾ 3ph, 4w, Open Delta, Center-Tapped ⁽⁺²⁾ 3ph, 4w, Delta, Center-Tapped ⁽⁺²⁾ 3ph, 4w, Wye, Ungrounded ⁽⁺²⁾ 3ph, 4w, Wye Grounded 3ph, 4w, Wye, Resistance Grounded ⁽⁺²⁾			

⁽⁺²⁾ Through communication in PM2100 series meters

PM2000 Series



Rear of PM2100 series with I/O module

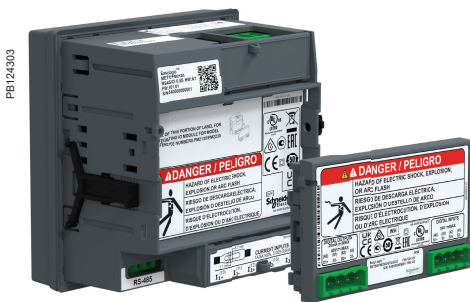

Rear of PM2100 series with I/O module disconnected

Technical specifications (continued)

Mechanical characteristics	
Weight	~ 300 g
IP degree of protection	IP54 front side, IP30 meter body as per IEC 60529; Upgrade to IP65 front side with Optional accessory kit METSEIP65OP96X96FF
Material	Polycarbonate meets UL 94V-0 flammability rating
Dimensions WxHxD	96x96x54 mm maximum (depth of the meter from housing mounting flange) and 13 mm (protrusion of meter from housing flange). Meter depth with IO module is 74 mm
Mounting position	Vertical
Panel thickness	5 mm maximum
Environmental characteristics	
Operating temperature	Meter -10 to +60 °C (14 to 140 °F)
Storage temperature	Meter -25 to +70 °C (-13 to 158 °F)
Humidity rating	5 to 95 % RH non condensing
Pollution degree	2
Altitude	≤ 2000 m (6562 ft) Category III
Product life	Minimum 7 years
Electromagnetic compatibility (tested as per IEC 61326-1)	
Electrostatic discharge	IEC 61000-4-2
Immunity to radiated field	IEC 61000-4-3
Immunity to fast transients	IEC 61000-4-4
Immunity to impulse waves	IEC 61000-4-5
Conducted immunity	IEC 61000-4-6
Immunity to magnetic fields	IEC 61000-4-8
Immunity to voltage dips	IEC 61000-4-11
Emissions	Emissions FCC Part 15 Class A/CE
Safety	
Europe	CE, as per IEC 61010-1 Ed-3
US and Canada	cULus as per UL61010-1 and CAN/CSA-C22.2 No. 61010-1, for 600 Vac
Measurement Category (Voltage and Current inputs)	CAT III up to 480 V L-L CAT II up to 600 V L-L
Overvoltage Category (Control power)	CAT III up to 300 V L-N
Dielectric	As per IEC/UL 61010-1 Ed-3
Protective Class	II, Double insulated for user accessible parts
Green premium	EOL, REACH, PEP, RoHS complied
Other certification	RCM (Australia), EAC (Russia)
Communication	
RS-485 port	Modbus RTU: 2-Wires, with ground & shield, 4800, 9600, 19200 or 38400 baud, Parity - Even, Odd, None, 1 stop bit if parity is Odd or Even, 2 stop bits if None DLF3000: Firmware update through communication port
Pulse Output – POP	Max 40 Vdc, 20 mA 20 ms ON time Configurable pulse weight from 1 to 9999000 pulses/k_h (kWh, kVAh, or kVARh)
Isolation	2.5 kV RMS, double insulated
Protection features	Password protected for set-up & clearing energy and Min/Max data
Display language (LCD)	English, Spanish, French, Chinese, German, Portuguese, Russian, Turkish
Technical publication	Printed installation guide (IG) with the meter in multi-language (EN, ES, FR, DE, PT, RU, TR, ZH)
Human machine interface	
Display type	LED display: 7 segment LED, ~ 14.2 mm height, 3 rows with 4 digits per row 2 columns of LEDs, one on each side of the LED panel to indicate the parameters under measurement LCD display: Monochrome graphical LCD of 128x128 pixels with viewable area of 67x62.5 mm
Keypad / Buttons	PM2100 series: 3 buttons for navigation & combination of 2 buttons for performing set-up, Lock/unlocking of page, Diagnostic page operation PM2200 series: 4 buttons for intuitive navigation of HMI/UI pages
Calibration LED Indicator	Red colour, meter constant is configurable from 1 to 9999000 pulses/k_h (kWh, kVAh, or kVARh)
Communication activity	Green LED (for indicating RS-485 interface or heartbeat pulse)

PM2000 Series



Rear of PM2200 series with I/O module



Digital I/O module



Analog I/O module

PM2000 series electrical characteristics of IO modules

Status Inputs (Digital Inputs)	
Voltage ratings	18.5 to 36 Vdc, OFF 0 to 4 Vdc
Input resistance	110 kW
Max Frequency	2 Hz (T ON min = T OFF min = 250 ms)
Detect Time	20 ms
Update time	1 s
Isolation	2.5 kV RMS
Supported models	Available as default feature in PM2125/PM2225 and Expandable option in PM2130/PM2230 meter model
Application	Integration of Breaker status or other non-electrical devices like steam, water, gas meter through pulse inputs
Display support	Available on PM2230/PM2225 (LCD type). In PM2130/PM2125 meter, data is available through communication only.
Set up and configuration	Through set-up software
Digital Outputs	
Voltage ratings	40 Vdc max, 20mA max
On Resistance	50 W max
Meter constant	Configurable from 1 to 9999000 k_h (kWh, kVARh, kVAh)
Pulse width	20, 25, 50, 100 ms
Pulse frequency (typical)	25 Hz
Leakage current	1 micro Amps
Isolation	2.5 kV RMS
Supported models	Available as default feature in PM2125/PM2225 and Expandable option in PM2130/ PM2230 meter model
Alarm conditions	23 set point driven standard alarms, 4 Unary alarms, 2 Digital inputs status
Application	Pulse output: configurable for energies upper / lower limit: configurable for 9 parameters with 14 set point: V L-L, V L-N, Amps, F, V-THD %, W-tot, VA-tot, VAR-tot, PF-avg
Display support	Available on PM2230/PM2225 (LCD type). In PM2130/PM2125 meter, data is available through communication only
Set up and Configuration	Through set-up software
Analog inputs	
Measurement scale	4-20 mA
Input impedance	≤300 W
Max source impedance	>500 W
Update rate	1 s
Accuracy	1 % of Full scale at ambient temp 0.1 %/K for de-rating
Voltage ratings	Typical 12 V (max 30 V)
Power Consumption	<1.5 W
Isolation	2.5 kV RMS
Supported models	Expandable option in PM2130/PM2230 meter models
Application	Configurable for inputs from flow rates, RPM, fluid level, oil pressure, temperature measurement devices or transducers with option of 81 different Uni code selection. Configuration via set up software
Display	Available on PM2230 (LCD type). In PM2130 meter, data is available through communication only
Set up and configuration	Through set up software
Analog outputs	
Scale	4-20 mA
Load impedance	≤600 W
Update rate	1 s
Accuracy	1 % of Full scale at ambient temp
Voltage ratings	Typical 12 V (max 30 V)
Power Consumption	<1.5 W
Isolation	2.5 kV RMS
Supported models	Expandable option in PM2130/PM2230 meter models
Application	Analog outputs can be associated to 40 different instantaneous parameters
Display	Available on PM2230 (LCD type). In PM2130 meter, data is available through communication only
Set-up & configuration	Through set-up software
Mechanical characteristics	
Mechanical dimension (WxHxD)	90.5 mm x 53 mm x 14.67 mm (without connector)
Weight	50 g

PM2000 Series

PE124307



Digital Input Relay Output module

PM2000 series electrical characteristics of IO modules

Relay Outputs	
Voltage rating	30 Vdc 5A load 250 Vac 8A, PF=1.0 250 Vac 6A, PF=0.4
Output Frequency	0.5 Hz maximum (1 second ON/1 second OFF)
Relay type	Mechanical, Form A, Potential free
Isolation	2.5 kV RMS
Supported models	Available as default feature in selected references in PM2125/PM2225 model. Expandable options in PM2130/PM2230 model.
Alarm conditions	23 set point driven standard alarms, 4 Unary alarms, 2 Digital inputs status
Application	Upper / lower limit: configurable for 10 parameters with 23 set points: V L-L, V L-N, Amps, F, V-THD %, W-tot, VA-tot, VAR-tot, PF-avg, last, present & predicted parameters for 3 power demands
Display and communication	Available on PM2230/PM2225 (LCD type). In PM2130/PM2125 meter, data is available through communication only
Set up and Configuration	Through ION set up software utility tool

Feature selection

Commercial ref. number	Model
METSEPM2110	PM2110
METSEPM2120	PM2120
METSEPM2125C2AI2AO	PM2125C ⁽⁺³⁾
METSEPM2125C2DI2RO	PM2125C ⁽⁺³⁾
METSEPM2130	PM2130
METSEPM2210	PM2210
METSEPM2220	PM2220
METSEPM2225C2AI2AO	PM2225C ⁽⁺³⁾
METSEPM2225C2DI2RO	PM2225C ⁽⁺³⁾
METSEPM2230	PM2230
METSEPM2KDGTLIO22	PM2K2DIDO
METSEPM2KANLGIO22	PM2K2AIAO
METSEPM2KANLGIO11	PM2K1AIAO
METSEPM2K2DI2RO	PM2K2DIRO

⁽⁺³⁾ Available in China only

Please contact your Schneider Electric representative for complete ordering information.

PM2000 Series

Feature set summary	PM2110	PM2120	PM2125C	PM2130	PM2210	PM2220	PM2225C	PM2230
Accuracy Class for Wh	1.0		0.5s		1.0		0.5s	
Accuracy Class for VARh	1.0							
Accuracy for VAh	±1.0 %		±0.5 %		±1.0 %		±0.5 %	
Current, per-phase, average and calculated neutral current	■							
Voltage, V L-N, V L-L, per-phase and average	■							
Power Factor	True PF	True PF Displacement PF ⁽⁺⁴⁾			True PF	True PF Displacement PF		
Frequency, any available phase	■							
Power: W, VA, VAR: per phase and total	■							
3-phase unbalance %	Current	Current Voltage ⁽⁺⁴⁾			Current	Current Voltage		
Demand parameters (Present, Last, Predicted and Peak for W, VA, VAR, A) Date and Time stamp for peak demand	■ (no timestamp)	■			■ (no timestamp)	■		
Energy: Wh, VAh, VARh (4 quadrant) Delivered (Import or Forward), Received (Export or Reverse)	Delivered, Received	Delivered, Received Total ⁽⁺⁴⁾ , Net ⁽⁺⁴⁾ , Last cleared ⁽⁺⁴⁾			Delivered, Received, Total, Net	Delivered, Received Total, Net, Last cleared		
Active load timer, meter operating timer, run hours and power outage counter	-	Through communication			-	■		
THD % and thd %: Voltage L-N or L-L, Amps per phase	■							
Individual harmonics for Voltage, Current, per-phase	-	Up to 15 th (+4)	Up to 15 th (+4)	Up to 31 st (+4)	-	Up to 15 th	Up to 15 th	Up to 31 st
Min/ Max with real time clock For avg or total of V L-L, V L-N, Amps, PF, Hz, W, VA, VAR parameters with date and time stamp of occurrence	-	Through communication			-	■		
RTC/battery ⁽⁺⁶⁾	-	■	■	■	-	■	-	■
Communication	Pulse Output	RS-485			Pulse Output	RS-485		
Expandable Analog IO module ⁽⁺⁵⁾ PM2K2AIAO: 2 input & 2 output channels METSEPM2KANLGO22 PM2K1AIAO: 1 input & 1 output channel METSEPM2KANLGO11	-	Embedded with 2AI/2AO			-	Embedded with 2AI/2AO		
Expandable Digital IO module ⁽⁺⁵⁾ PM2K2DIDO: 2 input & 2 output channels METSEPM2KDGTLIO22	-	-	-	■	-	-	-	■
Expandable DI RO module ⁽⁺⁵⁾ PM2K2DI2RO: 2 Digital input, 2 Mech Relay output channels. Whetting output voltage: 24V DC, 8 mA max load. METSEPM2K2DI2RO	-	-	Embedded with 2DI/2RO	■	-	-	Embedded with 2DI/2RO	■
Customizable data logging up to 2 parameters. Option to select Power (W, VA, VAR) Bi-directional energy (±Wh, ±VAh, ±VARh), Demand (W, VA, VAR, A) with configurable interval and duration (e.g., 2 parameters for 60 days at 15 minutes interval)	-	-	-	■	-	-	-	■
Alarms: 14 set point driven alarms from 9 parameters (V L-L, V L-N, Amps, F, V-THD %, W-tot, VA-tot, VAR-tot, PF-avg), 4 Unary alarms (meter power up, meter reset, meter diagnostic, phase reversal) and 2 digital inputs status (with DI/DO card only)	-	-	■	■	-	-	■	■
Daily time snapshot of Avg Voltage, Avg Current, Total active power & Energy delivered as measured at configurable time of day ⁽⁺⁷⁾	-	-	-	-	-	■	-	■
Rate counters: 2 configurable counters to display values in customer specified units base on energy measured (e.g., kgCO ₂ emission or energy cost) ⁽⁺⁷⁾	-	-	-	-	-	■	-	■
Commercial references								
Commercial reference starts with METSE***	PM2110	PM2120	PM2125C2AI2AO PM2125C2DI2RO	PM2130	PM2210	PM2220	PM2225C2AI2AO PM2225C2DI2RO	PM2230

⁽⁺⁴⁾ Through communication only

⁽⁺⁵⁾ Any one IO module can be used at a time with PM2130 or PM2230 meter. The control power range with IO module (including PM2125C/PM2225C references) shall be 72 to 304 Vac L-N or 90 to 304 Vdc.

⁽⁺⁶⁾ Battery backup duration 3 years when meter is in Power OFF condition.

⁽⁺⁷⁾ Configurable snapshot and rate counter features (not available in PM2125C/PM2225C meters)

PM2000 Series

PM2000 LCD display legend description

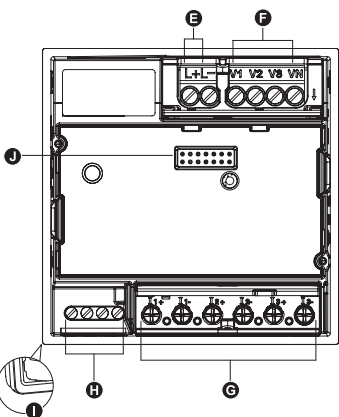
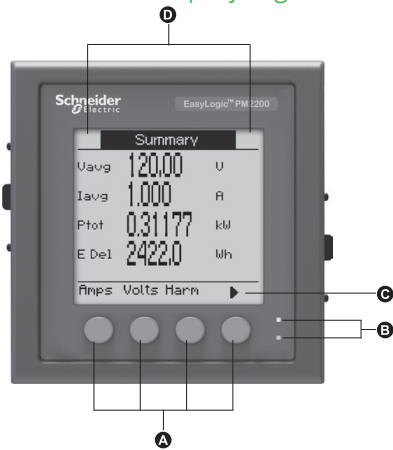

- A** Menu selection buttons
- B** Energy pulsing LED (red) Heartbeat / communications LED (green)
- C** Navigation or menu selections:
 - ▲ Exit screen and go up one level
 - ▲ Move cursor up list of options
 - ▼ Move cursor down, display more options
 - ◀ Move cursor one character to the left
 - ▶ Scroll right and display more menu items
 - + Show next item in list or increase the highlighted value
 - Show previous item in list
- D** Maintenance & alarm notification area
- E** Control power
- F** Voltage inputs
- G** Current inputs
- H** RS-485 / POP
- I** Gasket
- J** IO channel slot - optional accessory for PM2230, embedded in PM2225 meter

PM2000 LED display legend description

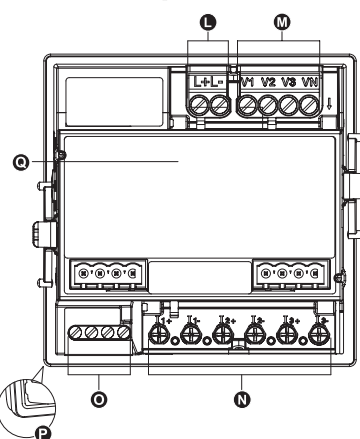
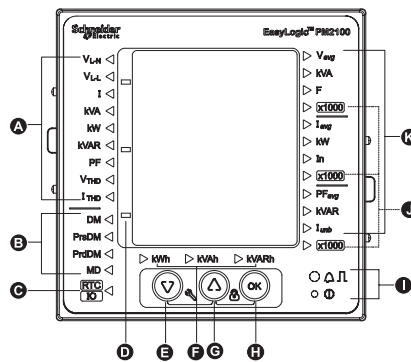

- A** Phase measurements (VL-N, VL-L, I, kVA, kW, kVAR, PF, V-THD %, I-THD %)
- B** Demand measurements (DM=Demand, PrsDM=Present demand, PrdDM=Predictor demand, MD=Maximum demand)
- C** RTC Date & time
- D** Negative indicator
- E** Navigation key to navigate down
- F** Energy readings Apparent energy, Active energy, Reactive energy
- G** Navigation key to navigate up
- H** OK Enter key
- I** Energy pulsing LED (red) Heartbeat / communications LED (green)
- J** x 1000 indicator
- K** System measurements Vavg, kVA, F, Iavg, kW, In, PFavg, kVAR, Iunb
- L** Control power L1, L2
- M** Input voltage terminals V1, V2, V3, VN
- N** Input current terminals I1+, I1-, I2+, I2-, I3+, I3-
- O** RS-485 communications / POP terminals
- P** Gasket
- Q** IO channel slot - optional accessory for PM2130, embedded feature in PM2125 meter

PM2000 Series

PM2000 LCD multi-function meter mechanical dimensions

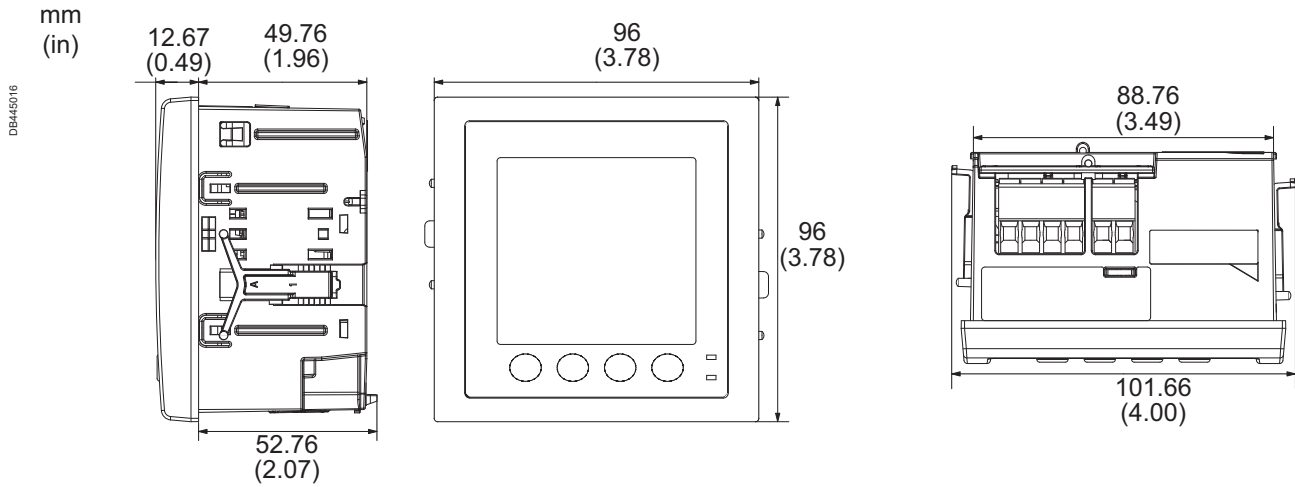

PM2000 LCD multi-function meter installation

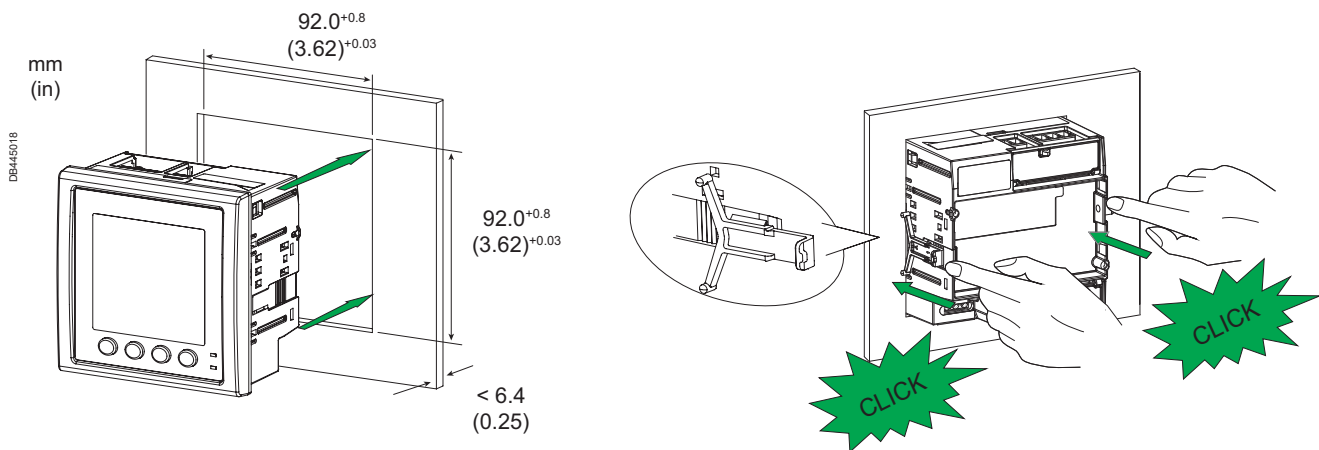

PM2000 LED multi-function meter mechanical dimensions

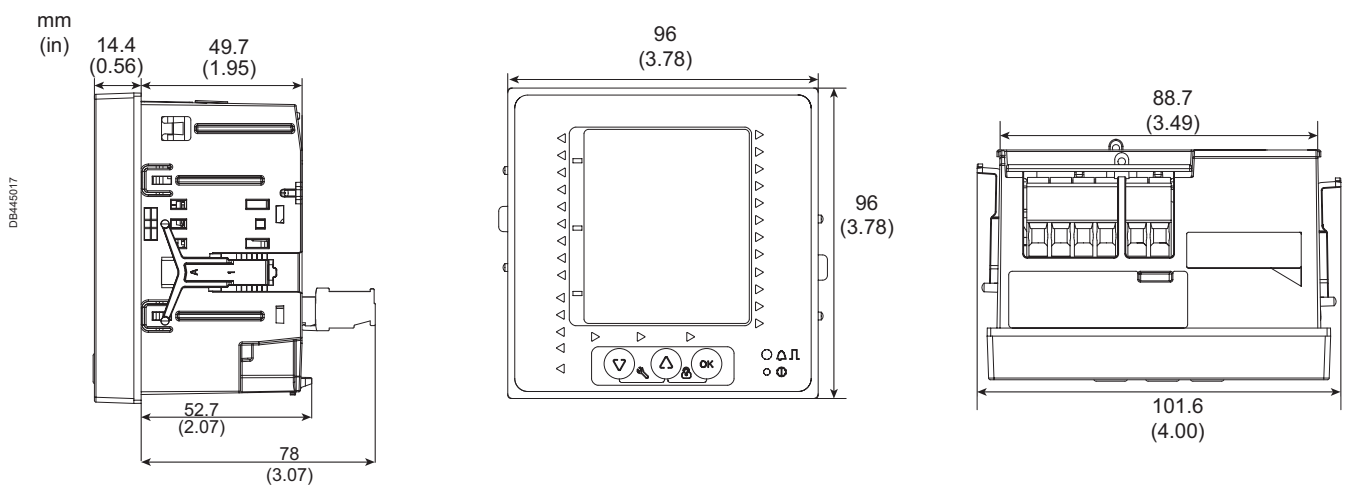

PM2000 Series

PM2000 LED multi-function meter installation

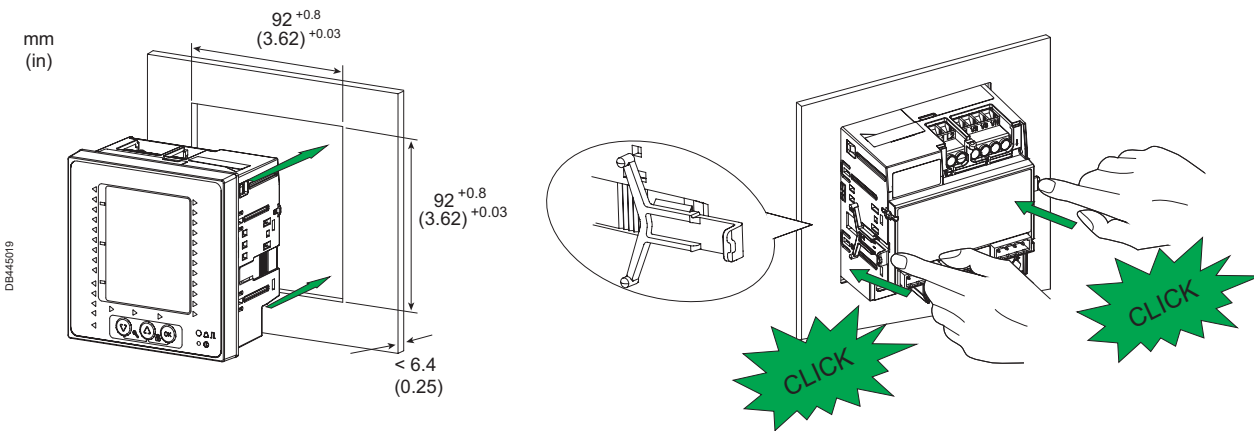

PM2000 Digital and Analog IO module mechanical dimensions

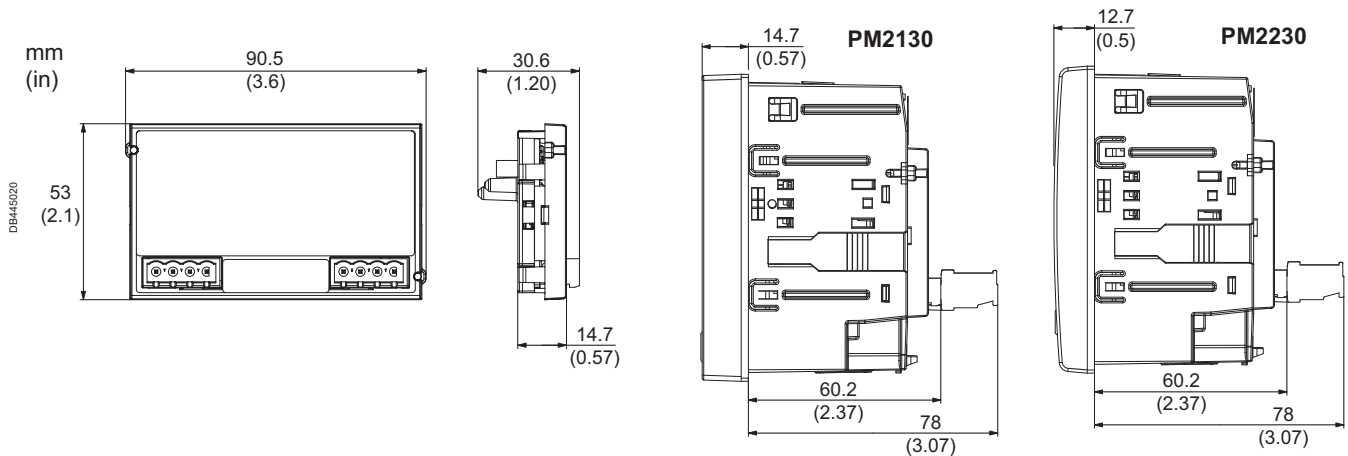

See the appropriate Installation Guide for correct installation instructions.

EasyLogic™ PM2220R Quick Click Technical Datasheet

The EasyLogic™ PM2220R multi-function power and energy meter with Quick Click CTS

Offering the same extensive measurement capabilities of the PM2220 meters - now with the option to significantly reduce installation time, cost, and complexity with new plug and play, 3-in-1 Quick Click CTS.

Applications

Cost management applications

- Bill checking to verify that you are only charged for the energy you use.
- Aggregation of energy consumption and cost allocation per area, per usage, per shift or per time within the same facility.
- Energy cost analysis per zone, per usage or per time period to optimize energy consumption.

Network management applications

- Metering of electrical parameters to better understand the behavior of your electrical distribution system.
- Power quality analysis.

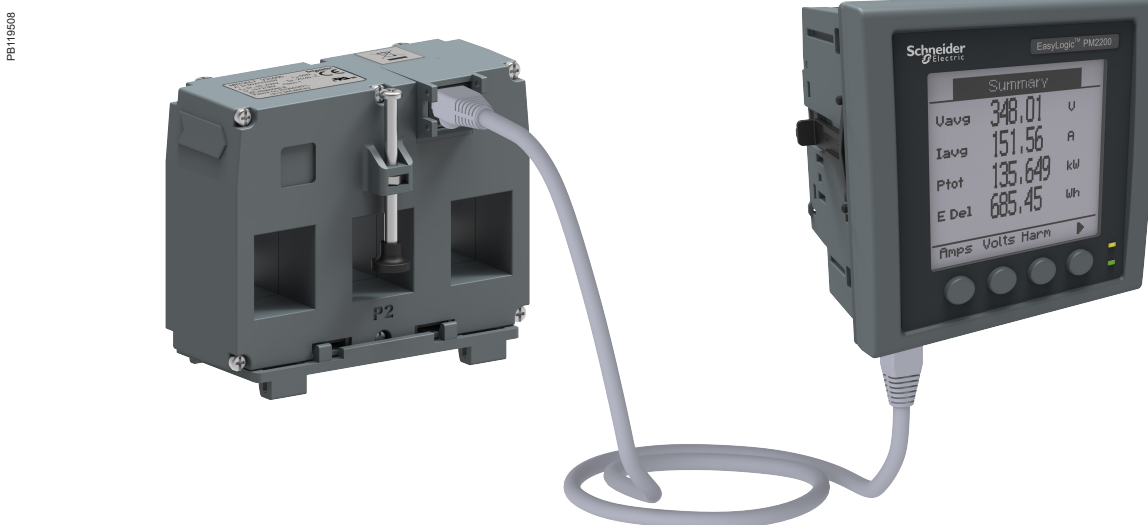

PB119508

PM2220R



PM2220R meter

Introducing the new Quick Click enabled EasyLogic PM2220R meter, next generation power meter, which offers all of the measurement capabilities of the PM2200 series with the added benefit of plug and play CT installation. For installers - time, labor, and rework savings of over 75% compared to traditionally wired meters with conventional CTs.

- Applications
 - Cost management:
 - Electrical installation remote monitoring
 - Energy accounting and balancing
 - Tenant and sub-billing
 - Panel instrumentation
 - Energy management
- Network management:
 - Power quality analysis: THD % and individual harmonics up to the 15th order (PM2220R).
 - Measurement of True PF and Displacement PF.
 - Recording Min/Max values of instantaneous parameters with date and timestamp.
 - Calculates % unbalance for voltage and current.

Feature selection

Commercial Ref. Number	Model
Meter Model	Description
METSEPM2220R	PM2220R power meter 15th Har RS-485 CI 1.0 Quick Click RJ45 LVCT
LVCTs	LVCT Solid 3-in-1 RJ45
METSECTV35006	LVCT Solid core 3 in 1 with RJ45 cable, 35 mm phase center, 60 Amps, 0.333V output, Class 1.0
METSECTV35010	LVCT Solid core 3 in 1 with RJ45 cable, 35 mm phase center, 100 Amps, 0.333V output, Class 1.0
METSECTV35013	LVCT Solid core 3 in 1 with RJ45 cable, 35 mm phase center, 125 Amps, 0.333V output, Class 1.0
METSECTV35016	LVCT Solid core 3 in 1 with RJ45 cable, 35 mm phase center, 160 Amps, 0.333V output, Class 1.0
METSECTV35020	LVCT Solid core 3 in 1 with RJ45 cable, 35 mm phase center, 200 Amps, 0.333V output, Class 1.0
METSECTV35025	LVCT Solid core 3 in 1 with RJ45 cable, 35 mm phase center, 250 Amps, 0.333V output, Class 1.0
METSECTV45025	LVCT Solid core 3 in 1 with RJ45 cable, 45 mm phase center, 250 Amps, 0.333V output, Class 1.0

Please contact your Schneider Electric representative for complete ordering information.

PM2220R

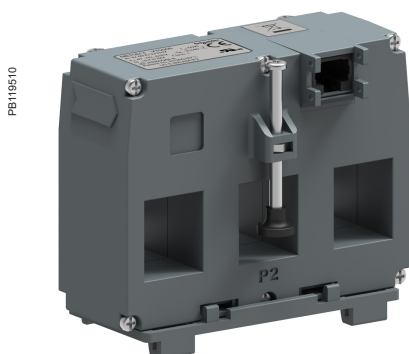

METSECTV35xxx series CT

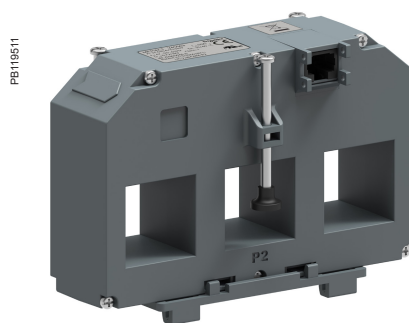

METSECTV45xxx series CT

- Main characteristics:
 - Simple CT connection and installation with Quick Click-enabled meters and LVCTs: A single RJ-45 port on the meter allows for direct connection to the RJ-45 port on Schneider Electric Quick Click CTs. As Quick Click CTs have a low voltage output, the shorting block required for traditional 5 A or 1 A output CTs is no longer needed. CT input screw terminals on the meter, screw terminals on the CTs, and screw terminals on the shorting block are all eliminated with the Quick Click solution.
 - Easy to install: Mounts using two clips, no tools are required. Compact meter with 54 mm depth, connectable up to $480 \pm 10\%$ V AC Volts L-L without voltage transformers for installations compliant with measurement category III, and double insulated.
 - Easy to operate: Intuitive navigation with self-guided menus and test LED at the front panel used for test and calibration of the meter on site or laboratory. Heart-beat LED indicates normal functioning and communication status if connected to RS-485 network.
 - Product standard compliance
 - Active energy Class 1.0 as per IEC 62053-21⁽⁺¹⁾.
 - Reactive energy Class 1.0 as per IEC 62053-24 (partial compliance for reactive energy test clause only).
 - Power quality analysis: The PM2220R offers THD % measurements and Individual harmonics up to the 15th order.
 - Load management: Simultaneous display of peak, present, predicted and rising demands of all the four demand parameters (W, VA, VAR, Amps)
 - Billing: Tenant billing/utility meter cross check (where local regulations are not applicable).
 - Timer: Active load timer, meter operation timer and run hours timer. These features help advise maintenance requirements and scheduling.
 - Display type: Monochrome graphical LCD of 128 x 128 resolution with viewable area of 67 x 62.5 mm lets the users read all three phase measured values simultaneously. The bright anti-glare display features large characters and powerful backlighting for easy reading even in extreme lighting conditions and viewing angles. Intuitive menus, multi-language text, icons and graphics create a user-friendly environment to learn about your electrical network.
 - Password: Field configurable password for securing set-up information and prevent tampering of integrated values.
 - Cyber security: Option for disabling RS-485 port through front panel keys against unauthorized access. It helps during installation and trouble shooting of communication network.
 - LCD display: 5 digits for energy, 5 or 6 digits for other parameters, with auto scaling.
 - Daily time snapshot (PM2220R): The values from summary page will be stored as snapshot and refreshed by a configurable time next day.
 - Rate counters (PM2220R): 2 configurable counters display values in custom specified units based on energy recorded (e.g., kgCO₂ carbon emission or energy cost).
 - Energy preset feature: For retrofit application.
 - Suppression current: To disregard measurement of induced current or negligible current flowing in the circuit, settable from 5 mA to 99 mA.

⁽⁺¹⁾ Meters have been tested to ANSI C12.20 and IEC 62053-21 standards, assuming an ideal CT.

PM2220R



PM2220R series meter - front display



PM2220R series meter - rear view

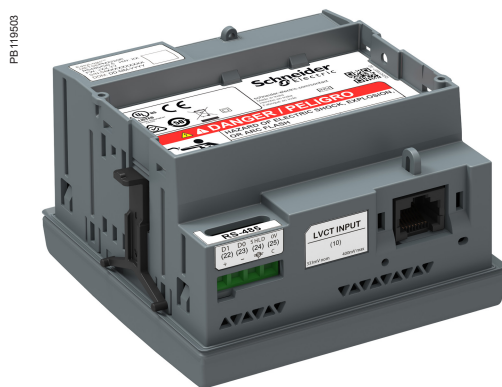

PM2220R series meter - underside view

PM2220R Technical Specifications

General	
Use on LV and MV systems with onsite programmable PT ratio	
Basic metering with THD %, Individual Harmonics, RTC and min/max readings	
Instantaneous RMS Values	
Current	Average line current of 3-phase, per-phase, and calculated neutral current
Voltage	Average voltage of L-L, L-N parameters, and per-phase
Frequency	Any available line
Real, reactive, and apparent power	Total and per-phase value
Displacement power factor	Average and per-phase signed, four quadrant
True Power Factor	Average and per-phase signed, four quadrant
% Unbalance	Among the phase for Amps, V L-N, V L-L
Energy Values Stored in Non-Volatile Memory	
Four quadrant measurement for Delivered (Forward or Import) and Received (Reverse or Export) energy	Accumulated energy values for Active, Reactive and Apparent Energy parameters, quadrant basis Net and Total (absolute) values
Timer	Accumulated time counters for active load timer, meter operation timer, run hours and power outage counter
Old Registers	Facilitates retrieval of last cleared energy values
Demand Values	
Current average	Present, Last, Predicted, Peak, and Peak Date Time
Active power	Present, Last, Predicted, Peak, and Peak Date Time
Reactive power	Present, Last, Predicted, Peak, and Peak Date Time
Apparent power	Present, Last, Predicted, Peak, and Peak Date Time
Demand sync methods	Thermal, Timed, Command Sync, and Clocked Sync
Demand calculation mode	Sliding, fixed and rolling block
Demand intervals	Settable from 1 to 60 minutes, in the step of 1 minute
Display	
PM2220R	Full-scope, monochrome graphical LCD of 128 x 128 resolution with viewable area of 67 x 62.5 mm
Visualization mode for signs	IEC or IEEE type in LCD display meter
Communication	
RS-485 serial	Channel connection Industry standard Modbus RTU protocol
Integration with software	SCADA / DCS / PMS / EMS / BAS / BMS software
Native Plug and Play support	Native plug-and-play support for: EcoStruxure™ Power Monitoring Expert, EcoStruxure™ Power Operation, ION Setup.
Min/Max Values	
Minimum and Maximum value recording of 3-ph average or total	For 8 parameters, viz., V L-L, V L-N, Amps, PF, Hz, W, VA, VAR with date and time stamp, resettable separately through set up mode
Diagnostics	
Diagnostic page	Indicates LCD status, serial number, diag pages, OS and RS version
Rate 1 Counter ⁽⁺²⁾	
kgCO ₂ emission (example)	Rate counter can be configured to display the CO ₂ emission in kgCO ₂ format based on the kWh measured either in delivered or received direction.
Rate 2 Counter ⁽⁺²⁾	
Tariff counter (example)	Rate counter can also be configured to calculate the electricity cost based on the energy consumption in customized currency format.
Daily Time Snapshot ⁽⁺²⁾	
Daily time snapshot	Snapshot of Avg Voltage, Avg Current, Total Active Power and Energy delivered as measured by the meter at configurable time of day. The static page will be refreshed with new values at a configured time next day

⁽⁺²⁾ Available in PM2220R.

PM2220R

PB119508



PM2220R with 35 mm CT attached

PM2220R Technical Specifications

Electrical Characteristics	
Type of measurement	True RMS 64 samples per cycle
Measurement Accuracy	
Current, average and per-phase	±0.5 %
Voltage average and per-phase	±0.5 %
Frequency	±0.05 %
Power Factor, average and per-phase	±0.01
Power (W-Active, VA- Apparent)	±0.5 %
Power (VAR- Reactive)	±1.0 %
Real / Active Energy (Wh)	Class 1.0
Reactive Energy	Class 1.0
Apparent Energy	±0.5 %
THD % and Individual Harmonics- V and A	±5 % FS for THD % and Individual harmonics
Input-Voltage	
VT primary	999 kV L-L max, secondary voltage depends on VT ratio
U nominal	277 V L-N/480 V L-L
Measured V with full range	20-277 V L-N/35 - 480 V L-L, cat III 20-347 V L-N/35 - 600 V L-L, cat II
Permanent overload	750 V AC L-L
Measured range	0.00333 V to 0.4 V
Frequency nominal	50/60 Hz
Input-Current	
CT ratings	Compatible with Schneider Electric Quick Click CTS with available primary current ratings of 60 A-1600 A Secondary 0.333 V
Frequency nominal	50/60 Hz
AC Control Power	
Operating range	44 - 277 Vac
Burden	<6 VA at 277 Vac L-N
Frequency	45 to 65 Hz
Ride-through time	100 ms typical at 120 Vac and maximum burden 400 ms typical at 230 Vac and maximum burden
DC Control Power	
Operating range	48-277 V DC ±10 %
Burden	< 2 W at 277 Vdc
Ride-through time	50 ms typical at 125 Vdc and maximum burden
Real Time Clock	
RTC with battery backup	3 years (when meter is in Power OFF condition - PM2220R)
Displays Update	
Instantaneous	1 s
Demand	15 s
Harmonics	5 s
Wiring Configuration	
User programmable	1ph, 2w, L-N 1ph, 2w, L-L 1ph, 3w, L-L with N (2phase) 3ph, 3w, Delta, Ungrounded 3ph, 3w, Delta, Corner Grounded 3ph, 3w, Wye, Ungrounded 3ph, 3w, Wye Grounded 3ph, 3w, Wye, Resistance Grounded 3ph, 4w, Open Delta, Center-Tapped 3ph, 4w, Delta, Center-Tapped 3ph, 4w, Wye, Ungrounded 3ph, 4w, Wye Grounded 3ph, 4w, Wye, Resistance Grounded

PM2220R

PM2200R Series

Mechanical Characteristics	
Weight	~ 300 g
IP degree of protection	IP54 front side, IP30 meter body as per IEC 60529 Upgrade to IP65 front side with optional accessory kit METSEIP65OP96X96FF
Material	Polycarbonate meets UL 94V-0 flammability rating
Dimensions W x H x D	96 x 96 x 54 mm maximum (depth of the meter from housing mounting flange) and 13 mm (protrusion of meter from housing flange).
Mounting position	Vertical
Panel thickness	5 mm maximum
Environmental Characteristics	
Operating temperature	Meter -10 to +60 °C (14 to 140 °F)
Storage temperature	Meter -25 to +70 °C (-13 to 158 °F)
Humidity rating	5 to 95 % RH non-condensing
Pollution degree	2
Altitude	≤2000 m (6562 ft), Category III
Product life	Minimum 7 years
Electromagnetic Compatibility (tested as per IEC 61326-1)	
Electrostatic discharge	IEC 61000-4-2
Immunity to radiated field	IEC 61000-4-3
Immunity to fast transients	IEC 61000-4-4
Immunity to impulse waves	IEC 61000-4-5
Conducted immunity	IEC 61000-4-6
Immunity to magnetic fields	IEC 61000-4-8
Immunity to voltage dips	IEC 61000-4-11
Emissions	Emissions FCC Part 15 Class A/CE
Safety	
Europe	CE, as per IEC 61010-1 Ed-3
US and Canada	cULus as per UL61010-1 and CAN/CSA-C22.2 No. 61010-1, for 480 V AC
Measurement Category (Voltage and Current inputs)	CAT III up to 480 V L-L CAT II up to 600 V L-L
Overvoltage Category (Control power)	CAT III up to 300 V L-N
Dielectric	As per IEC/UL 61010-1 Ed-3
Protective Class	II, Double insulated for user accessible parts
Compliance	EOL, REACH, PEP, RoHS complied
Other certification	RCM (Australia), EAC (Russia)
Communication	
RS-485 port (PM2220R)	Modbus RTU: 2-Wires, with ground and shield, 4800, 9600, 19200 or 38400 baud, Parity - Even, Odd, None, 1 stop bit if parity is Odd or Even, 2 stop bits if None DLF3000: Firmware update through communication port
Pulse Output	Max 40 V DC, 20 mA 20 ms ON time Configurable pulse weight from 1 to 9999000 pulses/k_h (kWh, kVAh, or kVARh)
Isolation	2.5 kV RMS, double insulated
Protection features	Password protected for set-up and clearing energy and Min/Max data
Display language	English, Spanish, French, Chinese, German, Portuguese, Russian, Turkish
Technical publication	Printed installation guide (IG) with the meter in multi-language (EN, ES, FR, DE, PT, RU, TR, ZH)
Human Machine Interface	
Display type	LCD display: Monochrome graphical LCD of 128 x128 mm resolution with viewable area of 67 x 62.5 mm
Keypad	4 buttons for intuitive navigation of HMI/ UI pages
CAL LED Indicator	Red color, meter constant is configurable from 1 to 9999000 pulses/k_h (kWh, kVAh, or kVARh)
Communication activity	Green LED (for indicating RS-485 interface or heartbeat pulse)

PM2220R

PM2220R Meter Rear

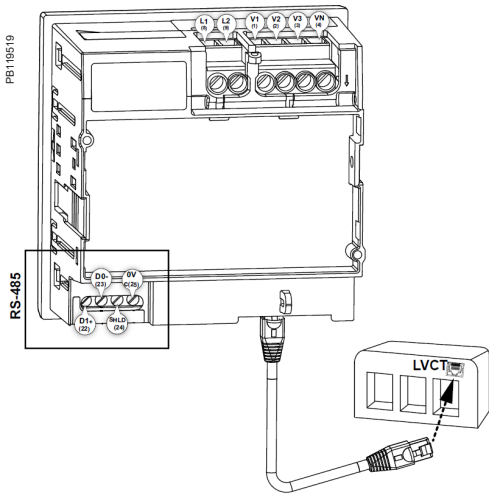

Feature Set Summary	PM2220R
Accuracy Class for Wh	1.0
Accuracy Class for VARh	1.0
Accuracy for VAh	±0.5 %
Amps, per-phase, average and calculated neutral current	■
Voltage, V L-N, V L-L, per-phase and average	■
Power Factor	True PF Displacement PF
Frequency, any available phase	■
Power: W, VA, VAR: per-phase and total	■
3-phase unbalance %	Current Voltage
Demand parameters (Present, Last, Predicted and Peak for W, VA, VAR, Amps) Date and Time stamp for peak demand	■
Energy: Wh, VAh, VARh (4 quadrant) Delivered (Import or Forward), Received (Export or Reverse)	Delivered, Received, Total, Net, Last cleared
Active load timer, meter operating timer, run hours and power outage counter	■
THD %: Voltage L-N or L-L, Amps per phase	■
Individual harmonics for Voltage, Current, per-phase Min/ Max with real time clock For avg or total of V L-L, V L-N, Amps, PF, Hz, W, VA, VAR parameters with date and time stamp of occurrence	Up to 15th ■
RTC/battery	■
Communication	RS-485
Daily time snapshot of Avg Voltage, Avg Current, Total active power and Energy delivered as measured every day at a configurable time	■

PM22xx Panel Grouping

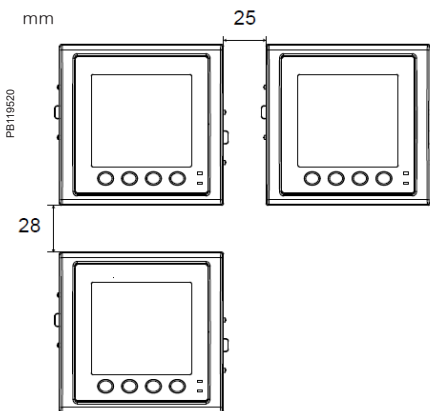

PM22xx Meter Installation

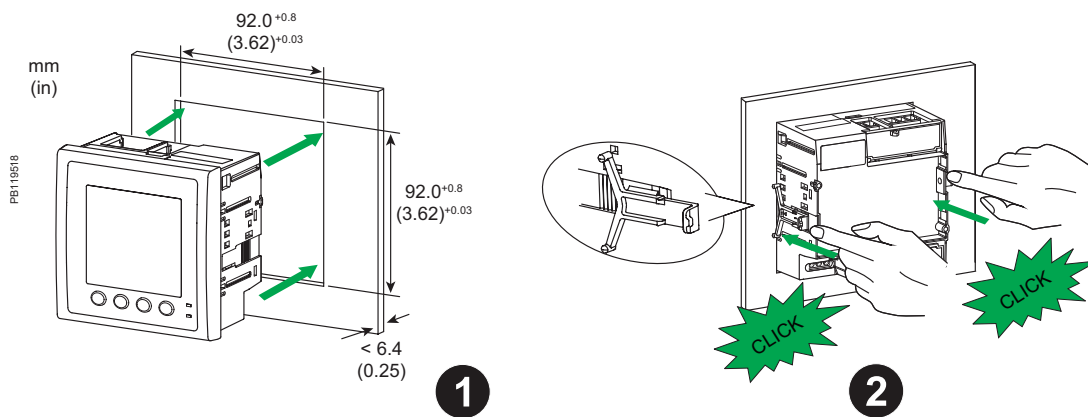

See the appropriate **Installation Guide** for correct installation instructions.

PM2220R

PM2220R Multi-Function Meter Mechanical Dimensions

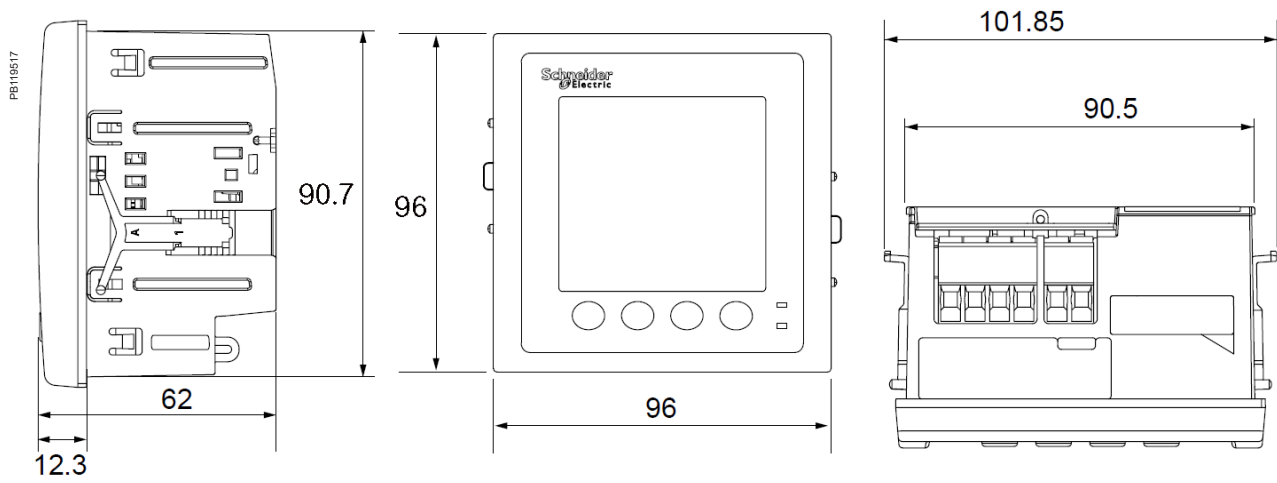

SECTV25xxx 3-in-1 LVCT Mechanical Dimensions

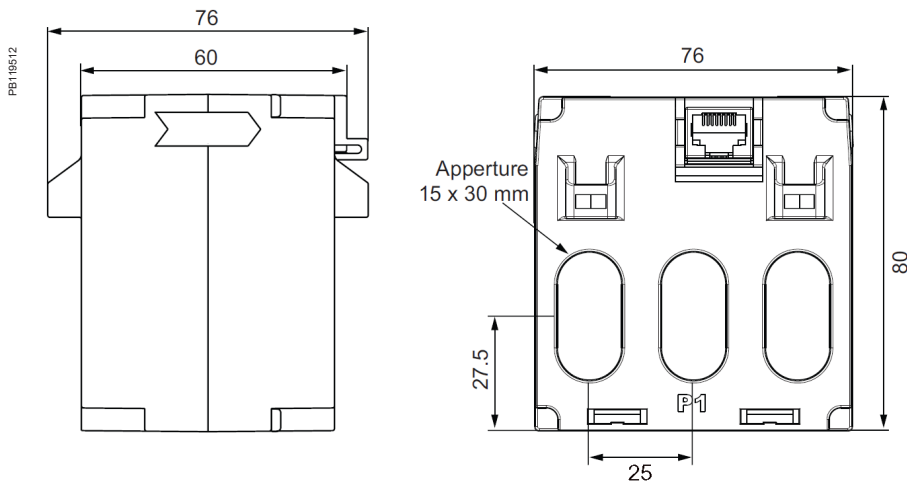

SECTV29xxx 3-in-1 LVCT Mechanical Dimensions

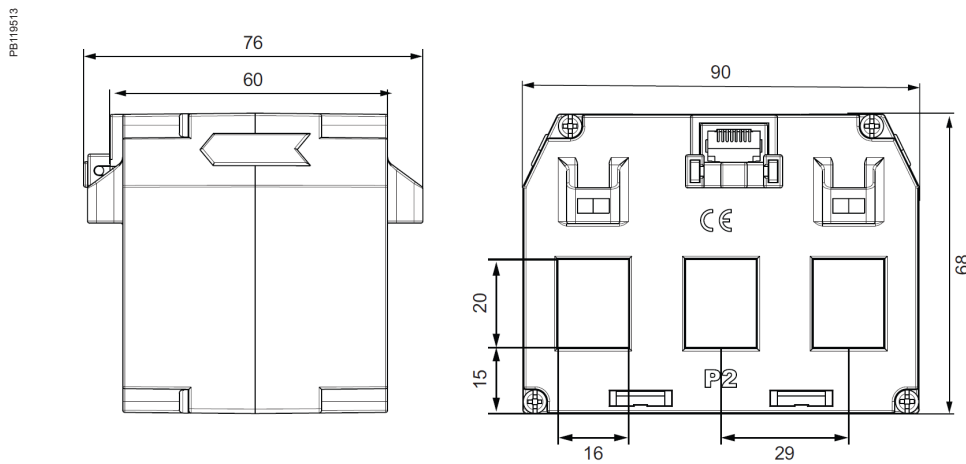

See the appropriate **Installation Guide** for correct installation instructions.

PM2220R

SECTV35xxx 3-in-1 LVCT Mechanical Dimensions

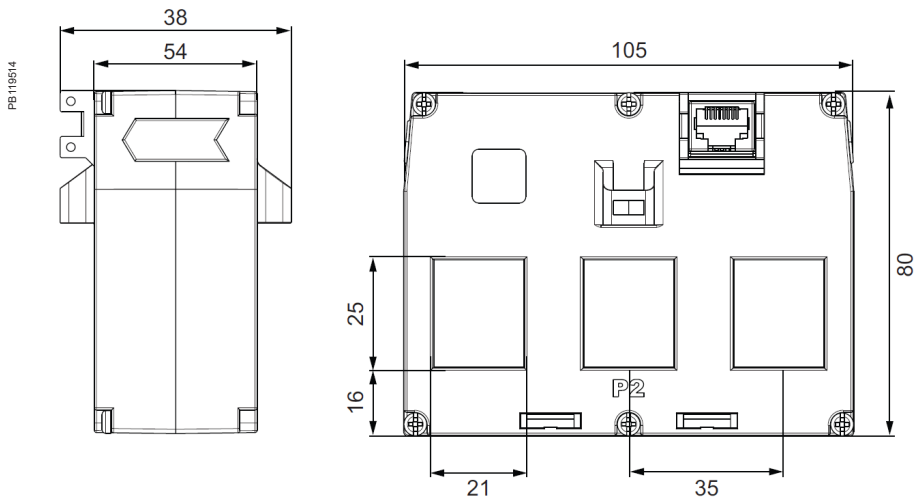

SECTV45xxx 3-in-1 LVCT Mechanical Dimensions

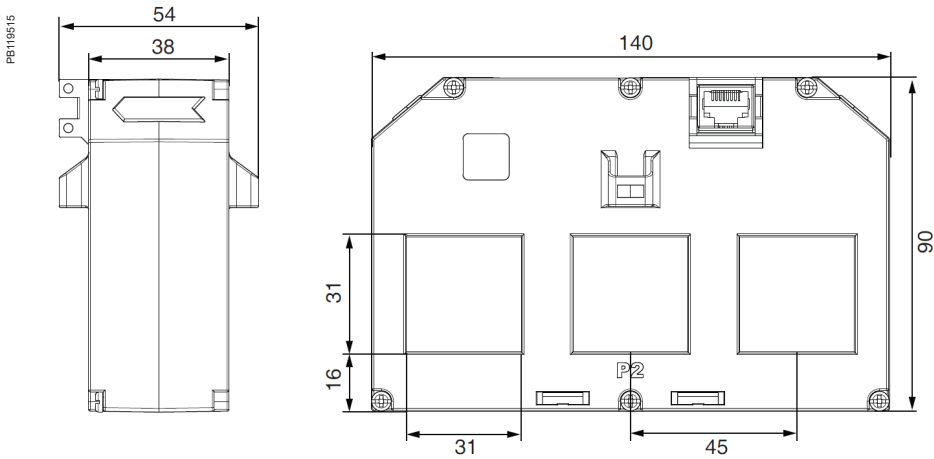

SECTV70xxx 3-in-1 LVCT Mechanical Dimensions

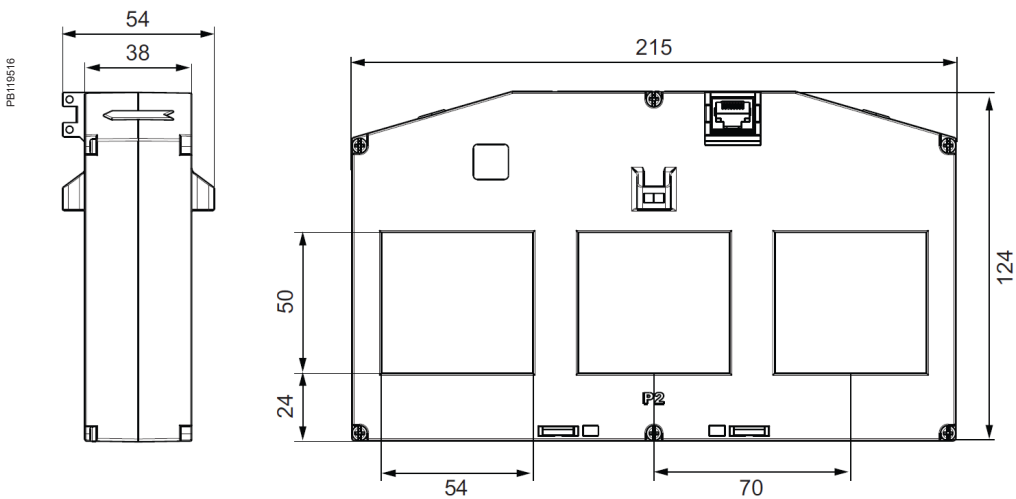

See the appropriate **Installation Guide** for correct installation instructions.

EasyLogic™ EM1000H Series

EM1000H Series energy meters in LCD display

The EasyLogic™ EM1000H Series energy meter offers all the basic energy measurement capabilities required to monitor an electrical installation in a single 96x96 mm unit. Characterized by their rugged construction, compact size, and low installation costs, these state-of-the-art meters are ideal for control panels, motor control centres, and genset panels.



EM1000H

PB124320

EM1000H Series



EasyLogic™ EM1000H front view



EasyLogic™ EM1000H rear view



EasyLogic™ EM1000H rear ISO view

EasyLogic™ meters are ideal replacements for multiple analog meters for stand-alone metering in custom panels, switch boards, switch-gear, genset panels, motor control centres, power factor improvement panels and OEM panel board.

- Application

- Cost management applications
 - Measurement of basic electrical parameters in control panels, motor control panels, power distribution boards, OEM's, Building management systems, panel instrumentation.
 - Aggregation of energy consumption and cost allocation per area, per usage, per shift and per time within the same facility.
- Network management applications
 - Measurement of Power Factor.
 - Modbus RTU protocol RS-485 communication port for integration with energy management system.

- Main characteristics

- Easy to install: Mounts using two retainer clips, no tools required. Compact meter with 49 mm meter depth behind the panel, connectable up to 480 V +10% AC volts L-L without voltage transformers for installation compliant with measurement category III, and double insulated.
- Easy to operate: Intuitive navigation with self-guided menus and Heart beat LED indicates normal functioning of meters while it conveys the communication status when connected to RS-485 network.
- LCD display: elegant, single row, bright, back lit graphical LCD display, 128*32 pixels. Fast, in-line view, three parameters, name and value at one glance.
- Power and energy: measurement, display and recording of all three power and corresponding energy parameter at a time (W/ Wh, VA/ VAh or VAR/ VARh). Any one combination of power and energy parameter for measurement in EM1220H
- Accuracy:
 - Class 1.0 for active energy as per the test limits given in IEC 62053-21
 - Class 2.0 for reactive energy as per the test limits given in IEC 62053-23
 - Tested in accordance with IEC 62052-11 for energy test requirements
 - EMI/ EMC tests: As per IEC 61326-1
- CT nominal: 5 A or 1 A I-nominal (field settable). CT reversal auto correction for energy consumption.
- Password: Field configurable password for securing set up information and prevents tampering of integrated values.
- Cyber security: Option for disabling RS-485 port through front panel keys against unauthorized access. This feature can also be used for maintenance and troubleshooting of complex communication network.
- Favourite page : The device enables user with the option to select parameters to be set in favourite page.
- Display: Auto scaling, 4 digits for Instantaneous parameters and 9+3 digits for energy parameter with auto scroll and auto range capability.
- Smart line indicators on LCD display meter: Helps check the presence of input supply voltage.
- Suppression current: To disregard the measurement of induced and panel auxiliary load current in the circuit (settable from 5 to 99 mA).
- Protective cover: Tamper-proof terminal screws do not detach from housing.
- Control power options: Universal range 44 to 300 V L-N ac/dc or Low voltage DC control power option of 9 to 36 Vdc.

EM1000H Series

Technical specifications

General	
Use on LV & MV systems with Potential transformer (PT or VT)/Current transformer (CT) ratio programmable at site	
Digital panel meters for measurement of basic electrical parameters	
Instantaneous rms values	
Real (active), reactive, and apparent power	Total and per-phase
True power factor	Average and per-phase signed
Energy values stored in non-volatile memory	
Delivered or forward or import energy from the grid - Accumulated or integrated active (Real - Wh), reactive (VARh) and apparent (VAh) energy	
Time counters such as meter ON Hours, load RUN Hours and power outage counters	
Old registers facilitate retrieval of last cleared energy values and load Run Hours	
Display	
LCD display: Elegant single row, bright back lit graphical LCD display 132 (Horizontal) * 32 (Vertical) pixels, 60 Degree angular view. Fast in-line view, three parameters name and value at one glance	
Communication	
RS-485 serial channel connection Industry standard Modbus RTU protocol	
Native Plug and Play support for Schneider Electric energy management system software - EcoStruxure™ Power Monitoring Expert, EcoStruxure™ Power Operation along with ION Setup programming support	
Diagnostics	
Diagnostic page indicates the healthiness of communication system, device serial number, device model number OS & RS version, communication status, error code display	
Page lock	
Page lock and unlock features. Once the commonly referred page is enabled for lock feature, then the display returns to locked page in 4 minutes of inactive time	
Favourite page	
Number and type of parameters can be chosen and arranged in Favourite page according to the user's requirement	
Electrical characteristics	
Type of measurement	True RMS, 4 quadrant power and 2 quadrant energy, 32 samples/ cycle
Measurement accuracy	
Current, per-phase & average	± 0.5 % of reading
Voltage, L-N, L-L, per-phase & average	± 0.5 % of reading
Frequency	± 0.05 % for F-nominal 50/60 Hz ± 2 Hz ± 0.2 % for Frequency range from 30 to 48 Hz, 52 to 58 Hz and 62 to 70 Hz
Power (active and apparent)	± 1.0 % for Class 1.0, ± 0.5 % for Class 0.5
Power (reactive)	± 2.0 % for Class 1.0
Power factor, per-phase & average	± 0.01 of reading
Active or real energy	Class 1.0 (± 1.0 %), Class 0.5 (± 0.5 %)
Apparent energy	± 1.0 % for Class 1.0, ± 0.5 % for Class 0.5
Reactive energy	Class 2.0 (± 2.0 %)
Input-voltage	
VT (PT) connection	Selectable from No VT (direct), 1 VT, 2 VT to 3 VT
VT (PT) primary	100 V L-L to 999 kV L-L max
U (V) nominal (secondary)	Up to 277 V L-N/ 480 V L-L (selectable VT secondary from 100, 110, 115, 120 to 415 V L-L)
Operating voltage range with accuracy	80-480 V L-L ± 10 % Category III
Measured Voltage with full range	35 to 600 V L-L
Permanent overload (withstand)	750 V L-L, continuous
Impedance	≥5 MΩ
Frequency range	50/60 Hz ± 2
VA burden	≤0.2 VA at 240 V L-N at 50 Hz
Input current	
CT connect	Solo or multi-phase current measurement by installing CT(s) in either of A1, A2, A3, A12, A23, A13, A123 phase(s)
CT primary	1 A to 32767 A programmable
CT secondary	1 A or 5 A I-nominal (field settable)
Operating current range with accuracy	10 mA to 6 A ⁽⁺¹⁾
Measured Amps with full range	5 mA to 10 A
Suppression current	5 to 99 mA (to disregard negligible load)
Permanent overload (withstand)	Continuous 10 A, 10 s/hr 50 A, 1s/hr 500 A
Impedance	0.3 mΩ
Frequency range	50/60 Hz ± 2 Hz
VA burden	≤0.1 VA at 5 A, 50 Hz

EM1000H Series

Technical specifications (continued)

AC - control power	
Operating range	48 to 277 V L-N ac \pm 10 %
Burden	\leq 4 VA at 240 V L-N, 50 Hz
Frequency	50/60 Hz nominal (45 to 65 Hz operating range)
Ride-through time	120 ms at 240 V L-N, 50Hz
DC - control power	
Operating range	48 to 277 Vdc \pm 10 % (Optional Low voltage DC control power option of 10 to 32 Vdc \pm 10 % is available in EM1220H)
Burden	\leq 2 W at 240 Vdc, $<$ 2 W at 24 Vdc
Ride-through time	120 ms at 240 Vdc
Display update	
Instantaneous/ RMS parameters	1 s
Power system	
Phase labelling	Configurable to 123, ABC, rst, pqr or ryb
Wiring configuration	13 wiring schemes (5 on front screen) 1ph, 2 w, L-N 1ph, 2 w, L-L 1ph, 3 w, L-L with N (2phase) 3ph, 3 w, Delta, Ungrounded 3ph, 3 w, Delta, Corner Grounded ⁽⁺²⁾ 3ph, 3 w, Wye, Ungrounded ⁽⁺²⁾ 3ph, 3 w, Wye Grounded ⁽⁺²⁾ 3ph, 3 w, Wye, Resistance Grounded ⁽⁺²⁾ 3ph, 4 w, Open Delta, Center-Tapped ⁽⁺²⁾ 3ph, 4 w, Delta, Center-Tapped ⁽⁺²⁾ 3ph, 4 w, Wye, Ungrounded ⁽⁺²⁾ 3ph, 4 w, Wye Grounded 3ph, 4 w, Wye, Resistance Grounded ⁽⁺²⁾
Mechanical characteristics	
Weight	\sim 300 gm (10.6 oz)
IP degree of protection	IP 51 front side, IP 30 meter body, tested as per IEC 60529 (IP 54 with optional gasket METSEIP54GK96X96FF or upgrade to IP65 front side with Optional accessory kit METSEIP65OP96X96FF)
Material	Polycarbonate meets UL 94V-0 flammability rating
Dimensions W x H x D	96x96x48 mm (3.78x3.78x1.89 in) (D = depth of the meter from housing mounting flange) 13 mm (0.51 in) protrusion of meter from housing flange
Mounting position	Vertical
Panel thickness	6 mm (0.25 in) maximum
Environmental characteristics	
Operating temperature	- 10 to +60 °C (14 to 140 °F)
Storage temperature	- 25 to +70 °C (-13 to 158 °F)
Humidity rating	5 % to 95 % RH non-condensing
Pollution degree	2
Attitude	\leq 2000 metres (6562 ft), Category III
Product life	$>$ 7 years
Insulation category	Double insulation for user accessible parts
Electromagnetic compatibility (tested as per IEC 61326-1)	
Electrostatic discharge	IEC 61000-4-2
Immunity to radiated field	IEC 61000-4-3
Immunity to fast transients	IEC 61000-4-4
Immunity to impulse waves	IEC 61000-4-5
Conducted immunity	IEC 61000-4-6
Immunity to magnetic fields	IEC 61000-4-8
Immunity to voltage dips	IEC 61000-4-11
Emissions (IEC61326-1)	Emissions CISPR 11 and FCC Part 15

⁽⁺¹⁾ Additional error of \pm 2% between 10 mA to 50 mA, \pm 1% between 50 mA to 100 mA

⁽⁺²⁾ Through communication

EM1000H Series

Technical specifications (continued)

Safety	
Europe	CE, as per IEC 61010 -1 and IEC 61326 - 1
US and Canada	cULus per UL 61010-1 CAN / CSA-C22.2 IEC 61010 - 1 - 12, for 480 Vac L-L
Measurement Category (Voltage inputs)	CAT III up to 480 V L-L
Overvoltage Category (Control power)	CAT III up to 300 V L-N
Dielectric	As per IEC/UL 61010-1 edition-3
Protective Class	II, Double insulated for user accessible parts
Green premium	EOL, REACH, PEP, RoHS complied
Communication	
RS-485 port	Modbus RTU: 2-Wire, 4800, 9600, 19200 or 38400 baud Parity - Even, Odd, None 1 stop bit if parity is Odd or Even, 2 stop bits if none
Isolation	2.5 kV RMS, double insulated
Protection features	User configurable password (selectable from 0000 to 9999) protected for set-up and clearing of energy, and other integrated data
Display language	English
Technical publication	Printed installation guide (QSG) supplied with meter in English and user guide in soft copy format
Human machine interface	
Display type - LCD	Segment Fast in-line view, three parameters, name and value at one glance. 3+1 digits for instantaneous parameters and 9+3 digits for energy parameters with auto scroll and auto range.
Keypad	4 buttons for navigation at the front, combination of 2 buttons for performing set-up, lock/unlock pages and viewing diagnostic pages
Calibration LED (pulse LED)	Red colour, meter constant is configurable from 1 to 9999000 pulses/k_h (kWh, kVAh, or kVARh)
Communication activity	Green LED (for indicating RS-485 interface or heartbeat pulse)

Feature set summary

Parameter/ Meter reference	EM1220H	EM1250H
Class of accuracy for active energy	Cl 1.0/Cl 0.5	Cl 1.0
Sampling rate per cycle	32	32
Class of accuracy (VARh)	2.0	2.0
Voltage, V L-N, V L-L, per-phase and average	■	-
Current, per-phase, average and calculated neutral current	■	-
Frequency, any available phase	■	-
Power factor: average and per-phase	■	■
Power W, VA, VAR - 4 quadrant, Total and per-phase	1 power at a time	■
Energy - delivered or forward or import energy: Wh, VAh, VARh - 2 quadrant	1 energy at a time	■
Old registers - retrieval of last cleared values of energy and Run Hours	■	■
Life time counter - meter ON Hours, Load Run Hours and number of power interruptions	■	■
Communication: 2 wire, RS-485, Modbus RTU protocol	■	■
Revolution per minute (RPM)	■	-
Commercial reference number		
Commercial reference for 44 - 300 Vac/dc control power	METSEEM1220HCL1 (Cl 1.0) METSEEM1220HCL5 (Cl 0.5)	METSEEM1250HCL1 (Cl 1.0)
Commercial reference for Low Voltage DC (9-36 V) option	METSEEM1220HCL5LVD (Cl 0.5)	

EM1000H Series

EM1000H Series meter mounting

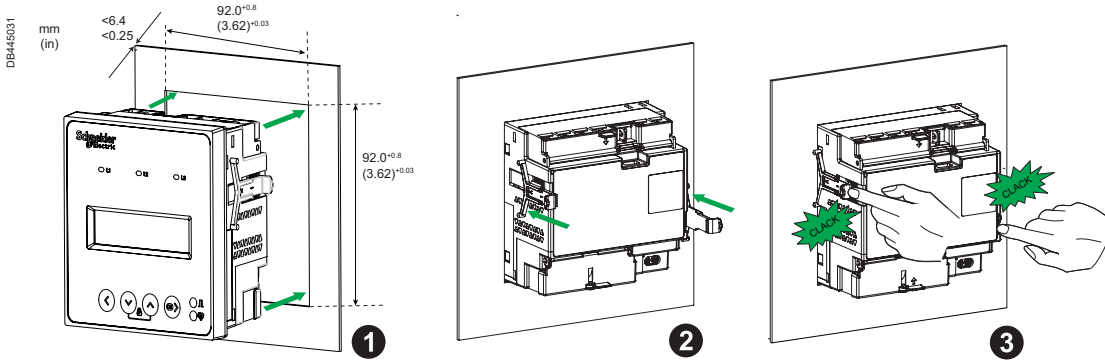

EM1000H Series meter mechanical dimensions

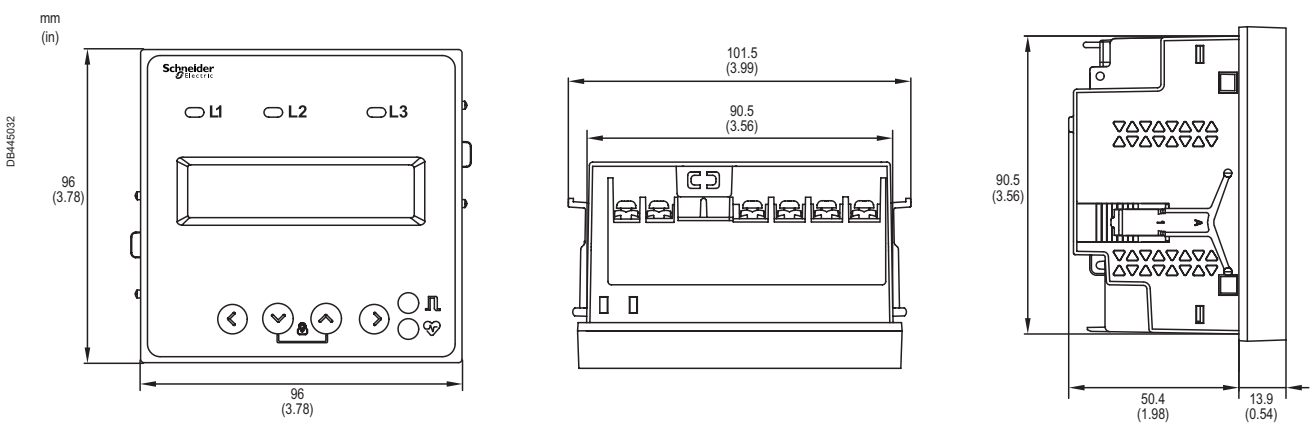

EM1000H Series meter LCD display overview

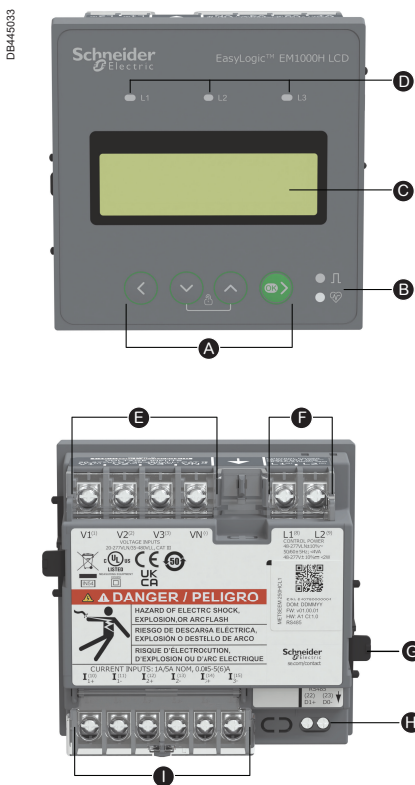

- A** Menu selection buttons
 - ◀ Left key: To navigate left
 - ▼ Down key: To navigate down
 - ▲ Up key: To navigate up
 - ➡ Right/OK key: To navigate right/Enter key
- B** LED indicators
 - Red: Pulse
 - Green: Heartbeat
- C** Alphanumeric LCD display
- D** Voltage line indicators
- E** Voltage inputs
- F** Control power
- G** Retainer clip
- H** RS-485
- I** Current inputs

See the appropriate **Installation Guide** for correct installation instructions.

EasyLogic™ PM1000H Series Technical Datasheet

The EasyLogic™ PM1000H Series basic power and energy meters

Offering all the measurement capabilities required to monitor the electrical installation in a single 96x96 mm unit, with 8 segment alphanumeric bright, large 14.2 mm high LED display (PM1110H, PM1120H, PM1125H, PM1130H and PM1140H).



PM1110H

EasyLogic™ PM1110H/PM1120/PM1125H/PM1140H/PM1130H meters are ideal replacements for multiple analog meters for stand-alone metering in custom panels, switch boards, switch-gear, genset panels, motor control centres, power factor improvement panels, and OEM panel board.

- Application
 - Cost management applications
 - Measurement of basic electrical parameters in control panels, motor control panels, power distribution boards, OEM's, Building management systems, and panel instrumentation.
 - Aggregation of energy consumption and cost allocation per area, per usage, per shift and per time within the same facility.
 - Network management applications
 - Power quality analysis (THD %)
 - Demand measurement
 - Measurement of Power Factor.
 - Phase angle between the voltage and current.
 - Percentage unbalance among voltage and current.
 - Modbus RTU protocol RS-485 communication port for integration with energy management system.

PM1000H Series



EasyLogic™ PM1000H Series front view LED display



EasyLogic™ PM1000H Series power meter rear view

- Main characteristics
 - Easy to install: Mounts using two retainer clips, no tools required. Compact meter with 49 mm meter depth behind the panel, connectable up to 480 V +10% ac volts L-L without voltage transformers for installation complaint with measurement category III, and double insulated.
 - Easy to operate: Intuitive navigation with self-guided menus and Heartbeat LED indicates normal functioning of meters while it conveys the communication status when connected to RS-485 network.
 - LED display: Intuitive navigation with self-guided, four buttons, 8 segment alphanumeric LEDs of height ~14.2 mm (0.55 in), and three lines of concurrent values with Kilo and Mega value indicators. 4 digits for instantaneous parameters and 5+3 (LED) for energy. Auto scaling and auto scrolling.
 - Power and energy: Measurement, display and recording of three power and corresponding energy parameters simultaneously in PM1110H, PM1125H and PM1140H - W/Wh, VAVAh and var/ varh.
 - Demand: Measurement of Peak, present and last demand values of either W, VA or VAR parameters with selectable demand parameter, demand interval and demand technique.
 - Accuracy:
 - Class 1.0 for active energy as per the test limits given in IEC 62053-21 and IEC 61557-12
 - Class 0.5s for active energy as per the test limits given in IEC 62053-22 and IEC 61557-12
 - Class 2.0 for reactive energy as per the test limits given in IEC 62053-23 and IEC 61557-12
 - Tested in accordance with IEC 62052-11 for energy test requirements
 - EMI/ EMC tests: As per IEC 61326-1
 - CT nominal: 5 A or 1 A I-nominal (field settable) CT reversal auto correction for energy consumption.
 - Password: Field configurable password for securing set up information and prevents tampering of integrated values.
 - Cyber security: Option for disabling RS-485 port through front panel keys against unauthorized access. This feature can also be used for maintenance and troubleshooting of complex communication network.
 - Favourite page: The device enables user with the option to select parameters to be set in favourite page.
 - Analog load bar in LED display type: The colour-coded analog load bar at the front side indicates the percentage of load through 12 LED's with the option to select full scale based on connected load.
 - Suppression current: To disregard the measurement of induced and panel auxiliary load current in the circuit (settable from 5 to 99 mA).
 - Protective cover: Tamper-proof terminal screws do not detach from housing.
 - Control power options: Universal range 44 to 300 V L-N ac/dc or Low voltage dc control power option of 9 to 36 Vdc.
 - Quadrant based varh: Measurement of total or net varh, quadrant based +varh and -varh.

PM1000H Series

Technical specifications

General	
Use on LV & MV systems with Potential transformer (PT or VT)/Current transformer (CT) ratio programmable at site	
Digital panel meters for measurement of basic electrical parameters	
Instantaneous rms values	
Current	Average line current of 3-phase, per-phase, and calculated neutral current
Voltage	Average voltage of L-L, L-N parameters, per-phase
Frequency	Any available line
Real (active), reactive, and apparent power	Total and per-phase
True power factor	Average and per-phase signed
% Unbalance	Maximum % unbalance among phases for Volts & Amps
Revolution per minute (RPM)	RPM of alternator or generator when number of poles set for 2, 4, 6, 8, 12, 14 or 16 (any one pole)
Energy values stored in non-volatile memory	
Delivered & Received or Forward & Reverse or Import & Export energy (4 quadrant) - Accumulated or Integrated active (Real - Wh), reactive (varh), apparent (VAh). 2 quadrant energy measurement in PM1120H, PM1130H and, PM1140H.	
Independent energy (Wh) counter with non-resettable feature.	
Energy values can be set for overflow units (e.g., in kilo or mega scale)(for 1225H)	
Quadrant based registers for Reactive energy	
Time counters such as meter ON Hrs, load RUN Hrs and power outage counters	
Old registers facilitate retrieval of last cleared energy values and load Run Hrs. Set up counters for tracking number of edits carried out since from installation	
Display	
LED display: Bright red colour, 8 segment alphanumeric LED, ~ 14.2 mm (0.55 in) height, 3 rows with 4 digits per row, auto range, auto scroll	
Communication	
Native Plug and Play support for Schneider Electric energy management system software - EcoStruxure™ Power Monitoring Expert, EcoStruxure™ Power Operation along with ION Setup programming support	
Diagnostics	
Diagnostic page indicates the healthiness of communication system, device serial number, device model number OS & RS version, communication status, All LED segment check in LED display.	
Favourite page	
Number and type of parameters can be chosen and arranged in Favourite page according to the user's requirement	
Electrical characteristics	
Type of measurement	True RMS, 4 quadrant power and energy, 32 samples/cycle
Measurement accuracy	
Current, per-phase and average	± 0.5 % of reading
Voltage, L-N, L-L, per-phase and average	± 0.5 % of reading
Frequency	± 0.05 % for F-nominal 50/60 Hz ± 2 Hz
	± 0.2 % for Frequency range from 30...48 Hz, 52...58 Hz and 62...70 Hz
Power (active and apparent)	± 1.0 % for Class 1.0, ± 0.5 % for Class 0.5
Power (reactive)	± 2.0 % for Class 1.0
Power factor, per-phase & average	± 0.01 of reading
Active or real energy	Class 1.0 (± 1.0 %), Class 0.5 (± 0.5 %)
Apparent energy	± 1.0 % for Class 1.0, ± 0.5 % for Class 0.5
Reactive energy	Class 2.0 (± 2.0 %)
THD %	± 5 % of reading
Input-voltage	
VT (PT) connection	Selectable from No VT (direct), 1 VT, 2...3 VT
VT (PT) primary	100 V L-L...999 kV L-L max
U (V) nominal (secondary)	Up to 277 V L-N/480 V L-L (selectable VT secondary from 100, 110, 115, 120...415 V L-L)
Operating voltage range with accuracy	80...480 V L-L ± 10 % Category III
Measured Voltage with full range	35...600 V L-L
Permanent overload (withstand)	750 V L-L, continuous
Impedance	≥5 MΩ
Frequency range	50/60 Hz ± 2
VA burden	≤0.2 VA at 240 V L-N at 50 Hz
Frequency – measurement	
Nominal operating range	50/60 Hz ± 2 Hz (± 0.05 % accuracy)
Extended operating range	30...48 Hz, 52...58 Hz and 62...70 Hz (± 0.2 % accuracy)
Voltage input	80...480 V L-L ± 10 %

PM1000H Series

Technical specifications (continued)

Input-current	
CT connect	Solo or multi-phase current measurement by installing CT (s) in either of A1, A2, A3, A12, A23, A13, A123 phase(s)
CT primary	1...32767 A, programmable
CT secondary	1 A or 5 Amps I-nominal (field settable)
Operating current range with accuracy	10 mA...6 A ⁽⁺¹⁾
Measured Amps with full range	5 mA...10 A
Suppression current	5...99 mA (to disregard negligible load)
Permanent overload (withstand)	Continuous 10 A, 10 s/hr 50 A, 1s/hr 500 A
Impedance	0.3 mΩ
Frequency range	50/60 Hz ± 2 Hz
VA burden	≤0.1 VA at 5 A, 50 Hz
AC - control power	
Operating range	48...277 Vac ± 10 %
Burden	≤4 VA at 240 V L-N, 50 Hz
Frequency	50/60 Hz nominal (45...65 Hz operating range)
Ride-through time	100 ms at 240 V L-N, 50 Hz
DC - control power	
Operating range	48...277 Vdc ± 10 % or Low Voltage dc option of 10...32 Vdc ± 10 % (for PM1225H)
Burden	≤2 W at 240 Vdc, <2 W at 24 Vdc
Ride-through time	50 ms at 125 Vdc
Display update	
Instantaneous/ RMS parameters	1 s
Demand parameters	5 s
THD % (voltage and current)	5 s
Power system	
Phase labelling	Configurable to 123, ABC, rst, pqr or ryb
Wiring configuration	13 wiring schemes (5 on front screen) 1ph, 2 w, L-N 1ph, 2 w, L-L 1ph, 3 w, L-L with N (2phase) 3ph, 3 w, Delta, Ungrounded 3ph, 3 w, Delta, Corner Grounded ⁽⁺²⁾ 3ph, 3 w, Wye, Ungrounded ⁽⁺²⁾ 3ph, 3 w, Wye Grounded ⁽⁺²⁾ 3ph, 3 w, Wye, Resistance Grounded ⁽⁺²⁾ 3ph, 4 w, Open Delta, Center-Tapped ⁽⁺²⁾ 3ph, 4 w, Delta, Center-Tapped ⁽⁺²⁾ 3ph, 4 w, Wye, Ungrounded ⁽⁺²⁾ 3ph, 4 w, Wye Grounded 3ph, 4 w, Wye, Resistance Grounded ⁽⁺²⁾
Mechanical characteristics	
Weight	~ 300 g (10.6 oz)
IP degree of protection	IP 51 front side, IP 30-meter body, tested as per IEC 60529 (IP 54 with optional gasket METSEIP54GK96X96FF or upgrade to IP65 front side with Optional accessory kit METSEIP65OP96X96FF)
Material	Polycarbonate meets UL 94V-0 flammability rating
Dimensions W x H x D	96 x 96 x 49 mm (3.78 x 3.78 x 1.93 in) (D = depth of the meter from housing mounting flange) 13 mm (0.51 in) protrusion of meter from housing flange
Mounting position	Vertical
Panel thickness	5 mm (0.196 in) maximum
Environmental characteristics	
Operating temperature	- 10...+60° C (14...140° F)
Storage temperature	- 20...+70° C (-4...158° F)
Humidity rating	5...95 % RH non-condensing
Pollution degree	2
Attitude	≤2000 metres (6562 ft), Category III
Product life	>7 years
Insulation category	Double insulation for user accessible parts

⁽⁺¹⁾ Additional error of ± 2 % between 10 mA to 50 mA, ± 1% between 50 mA to 100 mA

⁽⁺²⁾ Set up through communication

PM1000H Series

Technical specifications (continued)

Electromagnetic compatibility (tested as per IEC 61326-1)	
Electrostatic discharge	IEC 61000-4-2
Immunity to radiated field	IEC 61000-4-3
Immunity to fast transients	IEC 61000-4-4
Immunity to impulse waves	IEC 61000-4-5
Conducted immunity	IEC 61000-4-6
Immunity to magnetic fields	IEC 61000-4-8
Immunity to voltage dips	IEC 61000-4-11
Emissions	Emissions FCC Part 15 Class A/CE
Safety	
Europe	CE, as per IEC 61010-1 edition-3
US and Canada	cULus as per UL61010-1 and CAN/CSA-C22.2 IEC 61010-1 edition-3, for 480 Vac L-L
Measurement Category (Voltage inputs)	Category III up to 480 V L-L
Overvoltage Category (Control power)	Category III up to 300 V L-N
Dielectric	As per IEC/UL 61010-1 edition-3
Protective Class	Category II, Double insulated for user accessible parts
Green premium	EOL, REACH, PEP, RoHS complied
Communication	
RS-485 port	Modbus RTU: 2-Wires, 4800, 9600, 19200 or 38400 baud, Parity - Even, Odd, None, 1 stop bit if parity is Odd or Even, 2 stop bits if none. DLF3000: Firmware update through communication port
Isolation	2.5 kV RMS, double insulated
Protection features	User configurable password (selectable from 0000 to 9999) protected for set-up and clearing of energy, and other integrated data
Display language	English
Technical publication	Printed installation guide (QSG) supplied with meter in multi-language (EN, ES, FR, DE, PT, RU, TR, ZH) and user guide in soft format
Human machine interface	
Display type	LED display: 8 segment Alpha-numeric LED, ~ 14.2 mm (0.55 in) height, 3 rows with 4 digits per row, 1 column of 12 LEDs to indicate percentage of load connected in system. 4 digits for instantaneous parameters and 5+3 digits for energy parameters with auto scrolling and auto range
Keypad	4 buttons for navigation at the front, combination of 2 buttons for performing set-up, lock/unlock pages and viewing diagnostic pages
Calibration LED (pulse LED)	Red colour, meter constant is configurable from 1 to 9999000 pulses/ k_h (kWh, kVAh, or kvrh)
Communication activity	Green LED (for indicating RS-485 interface or heartbeat pulse)

Feature set summary

Parameter/Meter reference	PM1110H	PM1125H	PM1140H	PM1120H	PM1130H
Class of accuracy for active energy	Cl 1.0/Cl 0.5	Cl 1.0/Cl 0.5	Cl 1.0/Cl 0.5	Cl 1.0/Cl 0.5	Cl 0.5
Sampling rate per cycle	32	32	32	32	32
Amps: average and per-phase, calculated neutral current	-	■	■	■	■
Voltage: V L-N, V L-L, average, per-phase	-	■	■	■	■
Power factor: average and per-phase	■	■	■	■	■
Frequency: any available phase	-	■	■	■	■
Power (W, VA, Var) - Total and per-phase	■	■	■	■	■
Energy (Wh, Varh, VAh) - Delivered and Received	■	■	■ 1 energy (Del only)	■ 1 energy (Del only)	■ 1 energy (Del only)
Demand parameters – selectable for W, VA, Var (one at a time)	■	■	■	■	■
Old registers – retrieval of last cleared values of energy and Run Hrs	■	■	■	■	■
Revolutions per minute (RPM)	■	■	■	■	■
Phase angle : Amp Deg (V to Amps, per-phase)	■	■	■	■	■
% Unbalance: Max unbalance Volts and Amps among 3 phase (s)	■	■	■	■	■
Life time counter - meter ON Hrs, Load Run Hrs, number of power interruptions	■	■	■	■	■
Communication: 2 wire, RS-485, Modbus RTU protocol	■	■	■	■	■
Display	LED	LED	LED	LED	LED
Conformal Coating	■	■	-	■	■
1 Digital Input and 1 Relay Output (DIRO)	-	-	■	■	■
Commercial reference numbers					
Commercial reference for 44...300 Vac/dc control power	METSEPM1110HCL1 (Cl 1.0) METSEPM1110HCL05 (Cl 0.5)	METSEPM1125HCCL1 (Cl 1.0) METSEPM1125HCCL05 (Cl 0.5)	METSEPM1140HCL1 (Cl 1.0) METSEPM1140HCL1 (Cl 0.5)	METSEPM1120HCL10RS (Cl 1.0) METSEPM1120HCL05RS (Cl 0.5)	METSEPM1130HCL05RS (Cl 0.5)

PM1000H Series Dimensions

PM1110/PM1125H meter mechanical dimensions

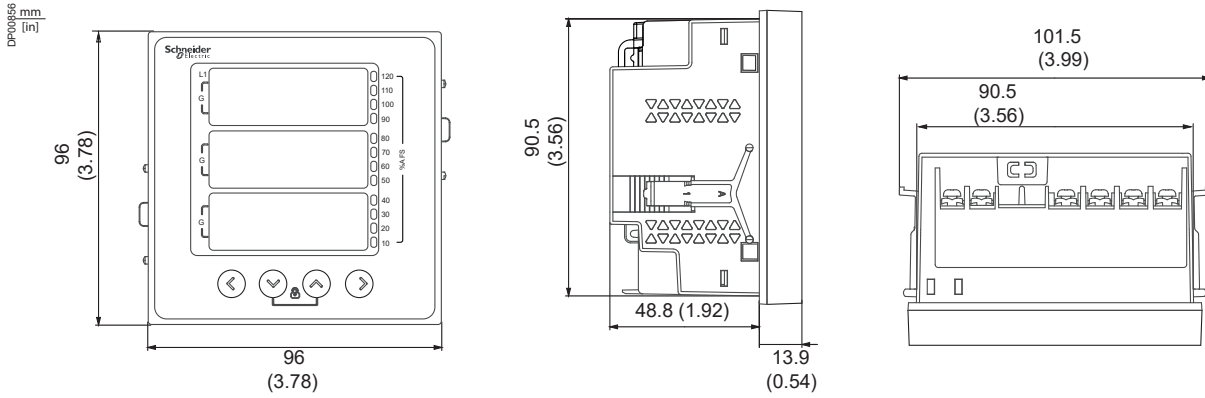

PM1110H meter mounting

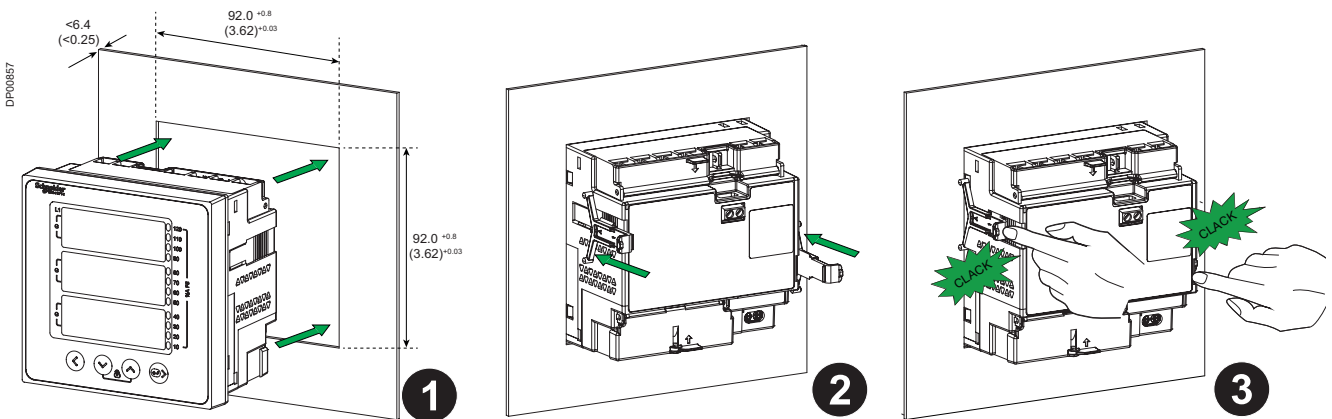

PM1140/PM1130 meter mechanical dimensions

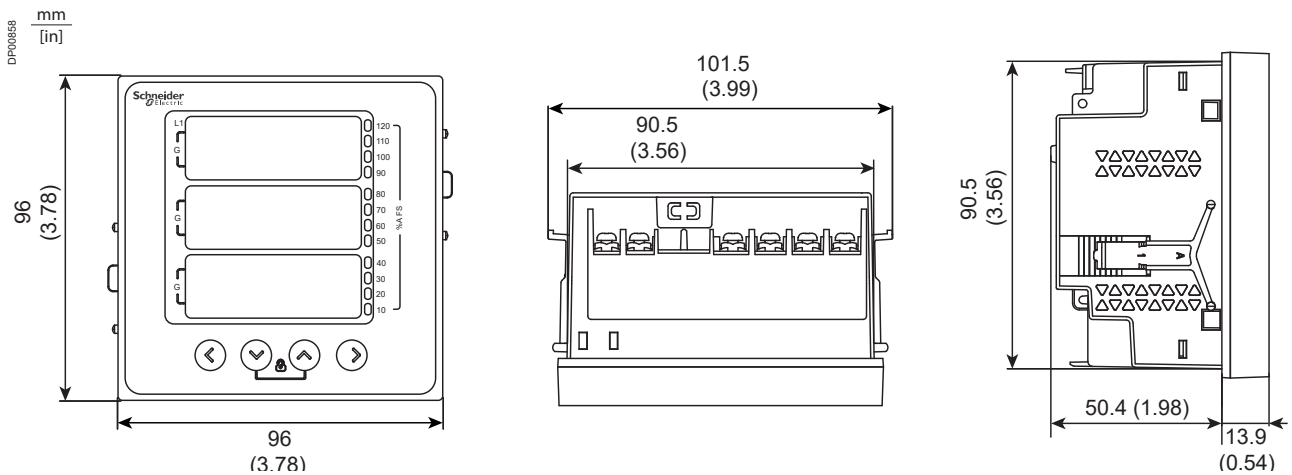

PM1000H Series Dimensions

PM1000H Series LED meter displays overview

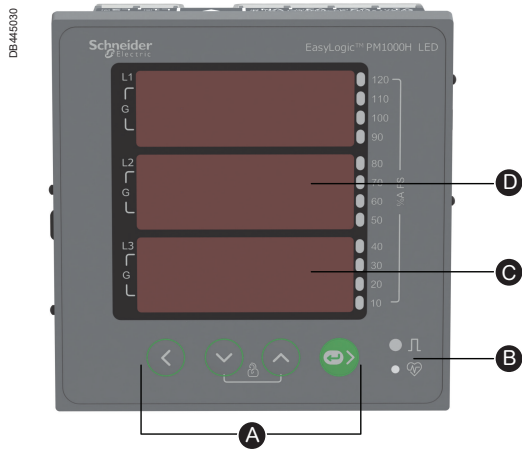

Front view for PM1140H Series

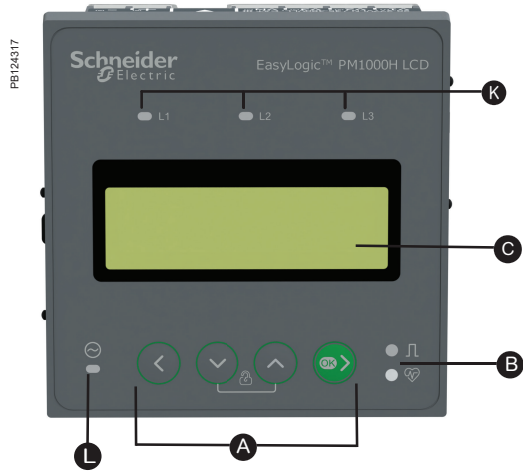

Front view for PM1110H

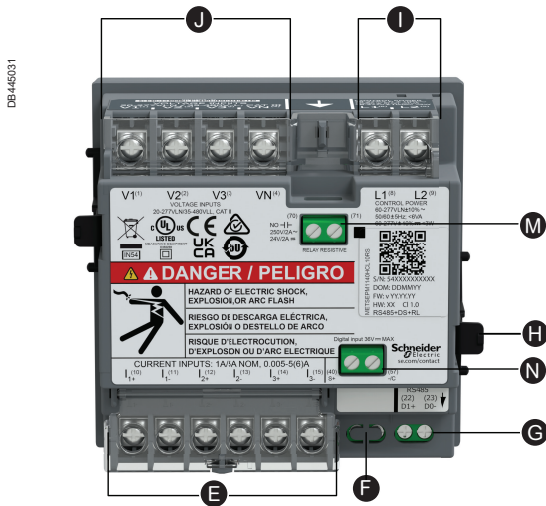

Rear view for PM1140 Series

- A** Menu selection buttons
 - ◀ Left key: To navigate left
 - ▼ Down key: To navigate down
 - ▲ Up key: To navigate up
 - ➡ Right/OK key: To navigate right/Enter key
- B** LED indicators
 - Red: Pulse
 - Green: Heartbeat
- C** Alphanumeric LED display
- D** Analog load bar
- E** Current inputs
- F** Alternate source (e.g. Genset)
- G** RS-485
- H** Retainer clip
- I** Control power
- J** Voltage inputs
- K** Voltage line indicators
- L** Dual source LED Indicator
- M** Relay resistive
- N** Digital input

EasyLogic™

PM1130H/PM1140H/PM1230H meters Technical Datasheet

EasyLogic™ PM1130H/PM1140H/PM1230H dual/alternate source power and energy meters.

Two energy registers (Utility vs Genset, Utility vs Solar, Utility vs Wind, or a combination of any two power sources) separately records consumption for dual source energy accounting. Ideal for any installation which requires split energy monitoring for two conditions, e.g., running and Idle. Form A relay to control the load in the event of abnormality in the electrical circuit including excess consumption of power. The meters can be used for secondary billing application in large commercial complexes or buildings as tenant meters in custom panels, switch boards, switchgear, genset panels, non-renewable energy panel and OEM panel board.

Offering all the measurement capabilities required to monitor the electrical installation in a single 96x96 mm unit.

PM1130H and PM1140H meter displays measured parameters and values in elegant three rows with 8 segment alphanumeric bright, large 14.2 mm height LED display.

PM1230H meter displays measured parameters and values in elegant single row, bright back lit graphical LCD display in 128*32 pixels size.

PB124309



PM1130H

PB124309



PM1230H

PM1130H/PM1140H/PM1230H

- Applications

- Cost management applications
 - Measure basic electrical parameters in control panels, power distribution boards, OEM's, and Building management systems
 - Aggregate energy consumption and cost allocation based on consumption from Utility vs Genset, or between any two power sources, per area, per shift and per time within the same facility
- Network management applications
 - Power quality analysis (THD %)
 - Demand measurement
 - Measurement of Power factor
 - Phase angle between the voltage and current
 - % unbalance among voltage and current
 - Modbus RTU protocol RS-485 port for integration with energy management system

- Main characteristics

- Easy to install: Mounts using two retainer clips, no tools required. Compact meter with 49 mm meter depth behind the panel, connectable up to 480 V +10% ac volts L-L without voltage transformers for installation complaint with measurement category III, and double insulated.
- Easy to operate: Intuitive navigation with self-guided menus and Heartbeat LED indicates normal functioning of meters while it conveys the communication status when connected to RS-485 network.
- LED display: Intuitive navigation with self-guided, four buttons, 8 segment alphanumeric LEDs of height ~14.2 mm (0.55 in), and three lines of concurrent values with Kilo & Mega value indicators. 4 digits for instantaneous parameters and 5+3 (LED) for energy. Auto scroll and auto range.
- LCD display: Elegant single row, bright back lit graphical LCD display 132*32 pixels, Fast in-line view, three parameters name and value at one glance. 4 digits for instantaneous parameters and 9+3 (LCD) for energy. Auto scroll and auto range.
- Power and energy: measurement, display and recording of three power and corresponding energy parameters simultaneously in PM1125H and PM1225H - W/Wh, VA/VAh and VAR/VARh.
- Demand: measurement of Peak, present and last demand values of either W, VA or VAR parameters with selectable demand parameter, demand interval and demand technique.
- Accuracy:
 - Class 1.0 for active energy as per the test limits given in IEC 62053-21 and IEC 61557-12
 - Class 0.5S for active energy as per the test limits given in IEC 62053-22 and IEC 61557-12
 - Class 2.0 for reactive energy as per the test limits given in IEC 62053-23 and IEC 61557-12
 - Tested in accordance with IEC 62052-11 for energy test requirements
 - EMI/EMC tests: As per IEC 61326-1
- CT nominal: 5 A or 1 A I-nominal (field settable). CT reversal auto correction for energy consumption.
- Password: Field configurable password for securing set up information and prevents tampering of integrated values.
- Cyber security: Option for disabling RS-485 port through front panel keys against unauthorized access. This feature can also be used for maintenance and troubleshooting of complex communication network.
- Favourite page: The device enables user with the option to select parameters to be set in favourite page.
- Analog load bar in LED display type: The colour-coded analog load bar at the front side indicates the percentage of load through 12 LED's with the option to select full scale based on connected load.
- Suppression current: To disregard the measurement of induced and panel auxiliary load current in the circuit (settable from 5 to 99 mA).
- Protective cover: Tamper-proof terminal screws do not detach from housing.
- Control power options: Universal range 44 to 300 V L-N ac/dc or Low voltage dc control power option of 9 to 36 Vdc.
- Smart line indicators in LCD display meter: Helps check the presence of input supply voltage (healthy phase).
- Relay: Form A, 2 terminals mechanical relay for alarm, control or annunciation if parameters exceeds or recedes set limit. Also activated on decremental energy from the preset energy value.
- Alternate/dual source power sensor supports multiple generator paralleling and bus coupler islanding schemes.
- Tamper cover protects against tampering with voltage and current terminals.
- Non-resettable energy counter to ensure integrity of energy readings.

PB124310



EasyLogic™ PM1130H/PM1140H dual source meter front view

PB124311



EasyLogic™ PM1140H DIRO meter rear view

PB124312



EasyLogic™ PM1230H dual source meter front view

PB124313



EasyLogic™ PM1130H and PM1230H dual source meter rear view

PM1130H/PM1140H/PM1230H

Technical specifications

General	
Use on LV & MV systems with Potential transformer (PT or VT)/Current transformer (CT) ratio programmable at site	
Digital panel meters for measurement of basic electrical parameters	
Instantaneous rms values	
Current	Average line current of 3-phase, per-phase, and calculated neutral current
Voltage	Average voltage of L-L, L-N parameters, per-phase
Frequency	Any available line
Real (active), reactive, and apparent power	Total and per-phase
True power factor	Average and per-phase signed
% Unbalance	Maximum % unbalance among phases for Volts & Amps
Revolution per minute (RPM)	RPM of alternator or generator when number of poles set for 2, 4, 6, 8, 12, 14 or 16 (any one pole)
Energy values stored in non-volatile memory	
Energy delivered from power source no.1 and power source no. 2: Accumulated active (Real - Wh) or reactive (VARh) or apparent (VAh) energy with user programmable alpha-numeric name	
Independent energy (Wh) counter with non-resettable feature.	
Energy values can be set for overflow units (e.g., in kilo or mega scale)	
Quadrant based registers for Reactive energy	
Time counters such as meter ON Hrs, load RUN Hrs for both source of power and power outage counters. Old registers facilitate retrieval of last cleared energy values and load Run Hrs	
Display	
LED display: Bright red colour, 8 segment alphanumeric LED, ~ 14.2 mm (0.55 in) height, 3 rows with 4 digits per row, auto range, auto scroll	
LCD display: Elegant single row, bright back lit graphical LCD display 132 (Horizontal) * 32 (Vertical) pixels. Fast in-line view, three parameters name and value at one glance	
Communication	
RS-485 serial channel connection Industry standard Modbus RTU protocol	
Native Plug and Play support for Schneider Electric energy management system software - EcoStruxure™ Power Monitoring Expert, EcoStruxure™ Power Operation along with ION Setup programming support	
Alternate or dual source sensor: For sensing the presence of alternate power source to measure and record energy in separate registers	
Diagnostics	
Diagnostic page indicates the healthiness of communication system, device serial number, device model number OS & RS version, communication status, All LED segment check in LED display. In LCD display meter - alternate pixels ON/ OFF test. LCD contrast level, set back-lit time out in the range of 1 to 99 seconds	
Page lock	
Page lock and unlock features. Once the commonly referred page is enabled for lock feature, then the display returns to locked page in 4 minutes of inactive time	
Favourite page	
Number and type of parameters can be chosen and arranged in Favourite page according to the user's requirement	
Relay	
Relay can be operated based on the set limits assigned for V L-L, V L-N, A, Hz, PF, Instantaneous power (W, VA, VAR), demand parameter (W, VA, VAR) Relay can also be programmed to activate based on decremental energy consumed in the system from the preset energy value	
Electrical characteristics	
Type of measurement	True RMS, 4 quadrant power and 2 quadrant energy, 32 samples/ cycle
Measurement accuracy	
Current, per-phase & average	± 0.5 % of reading
Voltage, L-N, L-L, per-phase & average	± 0.5 % of reading
Power (active and apparent)	± 1.0 % for Class 1.0, ± 0.5% for Class 0.5
Power (reactive)	± 2.0 % for Class 1.0 & Class 0.5
Power factor, per-phase & average	± 0.01 of reading
Frequency	± 0.05 % for F-nominal 50/ 60 Hz ± 2 Hz ± 0.2 % for Frequency range from 30 to 48 Hz, 52 to 58 Hz and 62 to 70 Hz
Active or real energy	Class 1.0 (± 1.0 %) Class 0.5 (± 0.5%)
Apparent energy	± 1.0 % for Class 1.0, ± 0.5% for Class 0.5
Reactive energy	Class 2.0 (± 2.0 %)
THD %	± 5 % of reading
Input-voltage	
VT (PT) connection	Selectable from No VT (direct), 1 VT, 2...3 VT
VT (PT) primary	100 V L-L...999 kV L-L max
U (V) nominal (secondary)	Up to 277 V L-N/ 480 V L-L (selectable VT secondary from 100, 110, 115, 120 to 415 V L-L)
Operating voltage range with accuracy	80-480 V L-L ± 10 % Category III
Measured Voltage with full range	35...600 V L-L
Permanent overload (withstand)	750 V L-L, continuous
Impedance	≥5 MΩ
Frequency range	50/60 Hz ± 2
VA burden	≤0.2 VA at 240 V L-N at 50 Hz

PM1130H/PM1140H/PM1230H

Technical specifications (continued)

Frequency – measurement	
Nominal operating range	50/60 Hz \pm 2 Hz (\pm 0.05 % accuracy)
Extended operating range	30...48 Hz, 52...58 Hz and 62...70 Hz (\pm 0.2 % accuracy)
Voltage input	80...480 V L-L \pm 10 %
Input-current	
CT connect	Solo or multi-phase current measurement by installing CT (s) in either of A1, A2, A3, A12, A23, A13, A123 phase(s)
CT primary	1 A...32767 Amps, programmable
CT secondary	1 A...5 Amps I-nominal (field settable)
Operating current range with accuracy	10 mA...6 A ^(*)
Measured Amps with full range	5 mA...10 A
Suppression current	5...99 mA (to disregard negligible load)
Permanent overload (withstand)	Continuous 10 A, 10 s/hr 50 A, 1s/hr 500 A
Impedance	0.3 m Ω
Frequency range	50/60 Hz \pm 2 Hz
VA burden	\leq 0.1 VA at 5 A, 50 Hz
AC - control power	
Operating range	60...277 V L-N ac \pm 10 %
Burden	\leq 6 V A at 240 V L-N, 50 Hz
Frequency	50/60 Hz nominal (45 to 65 Hz operating range)
Ride-through time	120 ms at 240 V L-N, 50Hz
DC - control power	
Operating range	60 to 277 V L-N dc \pm 10 % or Low Voltage dc option of 10 to 32 Vdc \pm 10 % for PM1230H
Burden	\leq 3 W at 240 Vdc, \leq 3 W at 24 Vdc
Ride-through time	120 ms at 240 Vdc
Display update	
Instantaneous/ RMS parameters	1 s
Demand parameters	5 s
THD % (voltage and current)	5 s
Power system	
Phase labelling	Configurable to 123, ABC, rst, pqr or ryb
Labelling for energy source identification – one letter settable	alpha-numeric, A to Y (except X), or 0...9
Wiring configuration	13 wiring schemes (5 on front screen) 1ph, 2 w, L-N 1ph, 2 w, L-L 1ph, 3 w, L-L with N (2phase) 3ph, 3 w, Delta, Ungrounded 3ph, 3 w, Delta, Corner Grounded ^(*) 3ph, 3 w, Wye, Ungrounded ^(*) 3ph, 3 w, Wye Grounded ^(*) 3ph, 3 w, Wye, Resistance Grounded ^(*) 3ph, 4 w, Open Delta, Center-Tapped ^(*) 3ph, 4 w, Delta, Center-Tapped ^(*) 3ph, 4 w, Wye, Ungrounded ^(*) 3ph, 4 w, Wye Grounded ^(*) 3ph, 4 w, Wye, Resistance Grounded ^(*)
Mechanical characteristics	
Weight	\sim 300 gm (10.6 oz)
IP degree of protection	IP 51 front side, IP 30-meter body, tested as per IEC 60529 (IP 54 with gasket METSEIP54GK96X96FF or upgrade to IP65 front side with Optional accessory kit METSEIP65OP96X96FF)
Material	Polycarbonate meets UL 94V-0 flammability rating
Dimensions WxHxD	96x96x51 mm (3.78x3.78x2.01 in) (D = depth of the meter from housing mounting flange) 13 mm (0.51 in) protrusion of meter from housing flange
Mounting position	vertical
Panel thickness	5 mm (0.196 in) maximum
Environmental characteristics	
Operating temperature	-10 to +60° C (+14 to +140° F)
Storage temperature	-20 to +70° C (-4 to +158° F)
Humidity rating	5...95 % RH non-condensing
Pollution degree	2
Attitude	\leq 2000 metres (6561 ft), Category III
Product life	>7 years
Insulation category	Double insulation for user accessible parts

^(*) Additional error of \pm 2 % between 10 mA to 50 mA, \pm 1 % between 50 mA to 100 mA

^(**) Through Communication

PM1130H/PM1140H/PM1230H

Technical specifications (continued)

Electromagnetic compatibility (tested as per IEC 61326-1)	
Electrostatic discharge	IEC 61000-4-2
Immunity to radiated field	IEC 61000-4-3
Immunity to fast transients	IEC 61000-4-4
Immunity to impulse waves	IEC 61000-4-5
Conducted immunity	IEC 61000-4-6
Immunity to magnetic fields	IEC 61000-4-8
Immunity to voltage dips	IEC 61000-4-11
Emissions	Emissions FCC Part 15 Class A
Safety	
Europe	CE, as per IEC 61010-1 edition-3
US and Canada	cULus as per UL61010-1 and CAN/CSA-C22.2 IEC 61010-1 edition-3, for 480 Vac L-L
Measurement Category (Voltage inputs)	CAT III up to 480 V L-L
Overvoltage Category (Control power)	CAT III up to 300 V L-N
Dielectric	As per IEC/UL 61010-1 edition-3
Protective Class	II, Double insulated for user accessible parts
Green premium	EOL, REACH, PEP, RoHS complied
Other certification	UKCA - PM1130H and PM1230H RCM and EAC - PM1130H
Communication	
RS-485 port	Modbus RTU: 2-Wires, 4800, 9600, 19200 or 38400 baud, Parity - Even, Odd, None, 1 stop bit if parity is Odd or Even, 2 stop bits if none.
Alternate or dual source sensor	2 pin connector, suitable for pair of 1.5 sq mm multi-strand or single strand cable AC: 80 - 277 V L-N $\pm 10\%$ ON status, 0 to 30 V L-N OFF status DC: 18 - 60 Vdc $\pm 10\%$ ON status, 0 to 4 Vdc OFF status
Relay output	Form A relay, 2 pins terminal, externally excited with 300 V L-N ac max./2 A or 24 Vdc/2 A
Isolation	2.5 kV RMS, double insulated
Protection features	Password protected for set-up parameters, energy clearing, and other integrated data
Display language	English
Technical publication	Printed installation guide (QSG) supplied with meter in multi-language (EN, ES, FR, DE, PT, RU, TR, ZH) and user guide in soft format
Human machine interface	
Display types	LED display: Intuitive navigation with self-guided, four buttons, 8 segment alphanumeric LEDs of height ~14.2 mm (0.55 in), and three lines of concurrent values with Kilo & Mega value indicators. 4 digits for instantaneous parameters and 5+3 (LED) for energy.
	LCD display: Elegant single row, bright back lit graphical LCD display 132*32 pixels, Fast in-line view, three parameters name and value at one glance. 4 digits for instantaneous parameters and 9+3 (LCD) for energy.
Keypad	4 buttons for navigation at the front, combination of 2 buttons for lock/unlock pages
Calibration LED (pulse LED)	Red colour, meter constant is configurable from 1 to 9999000 pulses/k_h (kWh, kVAh, or kVARh)
Communication activity	Green LED (for indicating RS-485 interface or heartbeat pulse)
Alternate or dual source LED	Red colour LED glows continuously during the presence of ac or dc voltage across the dual source sensor

PM1130H/PM1140H/PM1230H

Feature set summary

Parameter/ Meter reference	PM1140H	PM1130H	PM1230H
Accuracy Class of Wh (active energy)	Cl 1.0/Cl 0.5	0.5 (± 0.5 %)	1.0 (± 1.0%)/ 0.5 (± 0.5%)
Accuracy Class of VARh (reactive energy)	2.0 (± 2.0 %)	2.0 (± 2.0 %)	2.0 (± 2.0%)
Amps: average and per-phase, calculated neutral current	■	■	■
Voltage: V L-N, V L-L, average, per-phase	■	■	■
Power factor: average and per-phase	■	■	■
Frequency: any available phase	■	■	■
Power (W, VA or VAR – any one) Measurement and display of any one power parameter at a time, configurable through set-up/ communication	■	■	■
Energy (Wh, VAh, VARh)- delivered or forward or import energy: One energy measurement based on power parameter selection	■ 1 energy (Del only)	■	■
Demand - selectable for W, VA, VAR (one parameter at a time)	■	■	■
Total Harmonic Distortion (THD %)	■	■	■
Relay, Form A type	■	■	■
Old registers - retrieval of last cleared values of source 1 & source 2 energy, source 1 and source 2 load run Hrs	■	■	■
Revolutions per minute (RPM)	■	■	■
Phase angle : Amp Deg (V to Amps, per-phase)	■	■	■
% Unbalance: Maximum of 3-ph V and Amps	■	■	■
Life time counter - meter ON Hrs, source 1 Load Run Hrs, source 2 Load Run Hrs and number of power interruptions	■	■	■
Communication: 2 wire, RS-485, Modbus RTU protocol	■	■	■
Display type	LED	LED	LCD
Digital Input	■	-	-
Commercial reference number			
Commercial reference for 60 - 277 V ac/dc control power	METSEPM1140HCL1 (Cl 1.0) METSEPM1140HCL1 (Cl 0.5)	METSEPM1130HCL05RS (Cl 0.5)	METSEPM1230HCL1 (Cl 1.0) METSEPM1230HCL5 (Cl 0.5)
Commercial reference for Low Voltage dc (9-36 V) option			METSEPM1230HCL5LVD (Cl 0.5)

PM1130H/PM1230H series dual source meter display overview

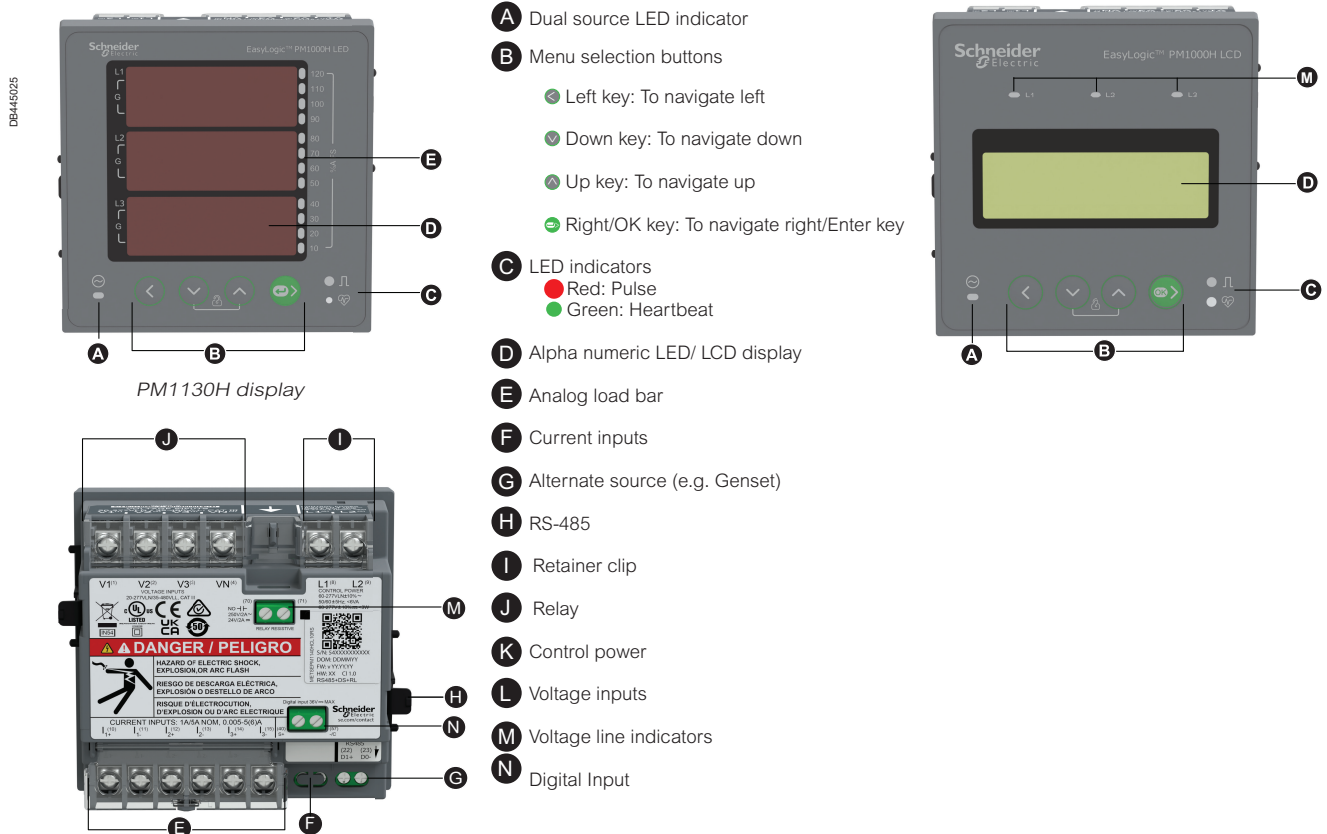

PM1130H/PM1140H/PM1230H

PM1230H dual source meter mechanical dimensions

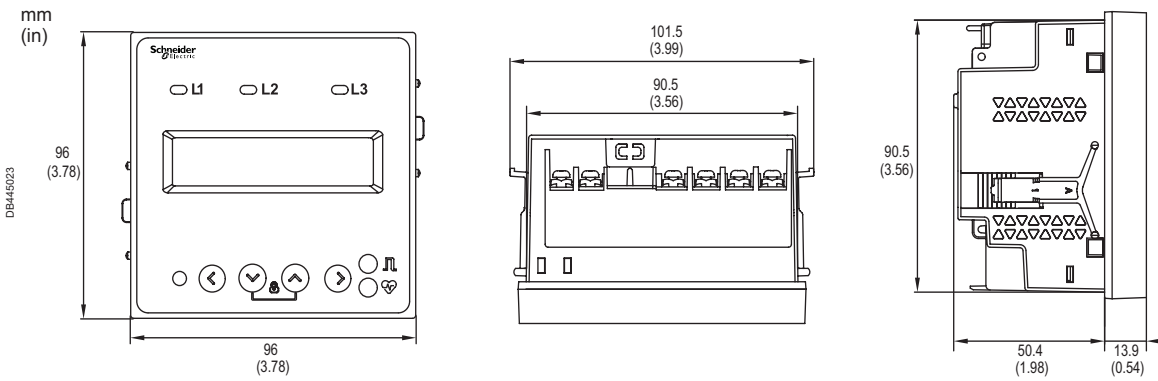

PM1230H dual source meter installation

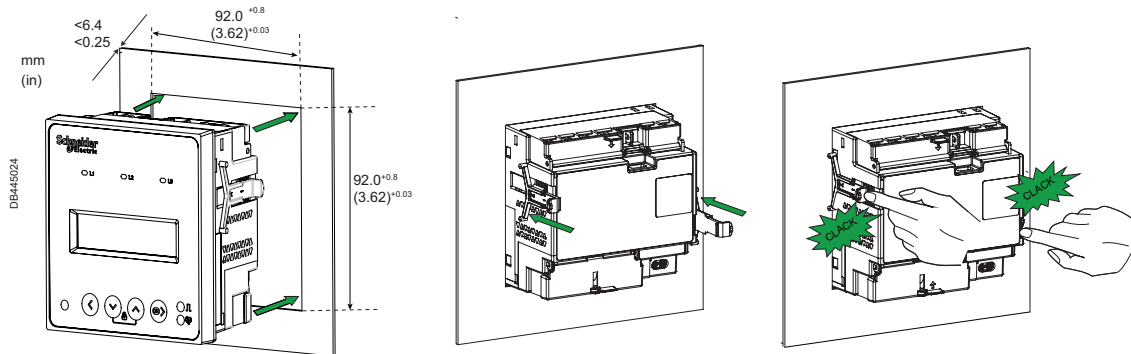

PM1130H dual source/PM1140H DIRO meter mechanical dimensions

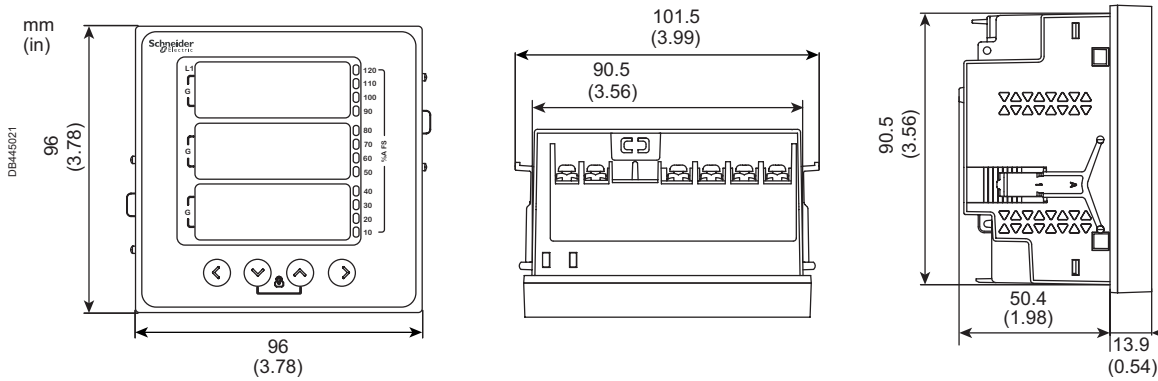

PM1130H and PM1140H DIRO dual source meter installation

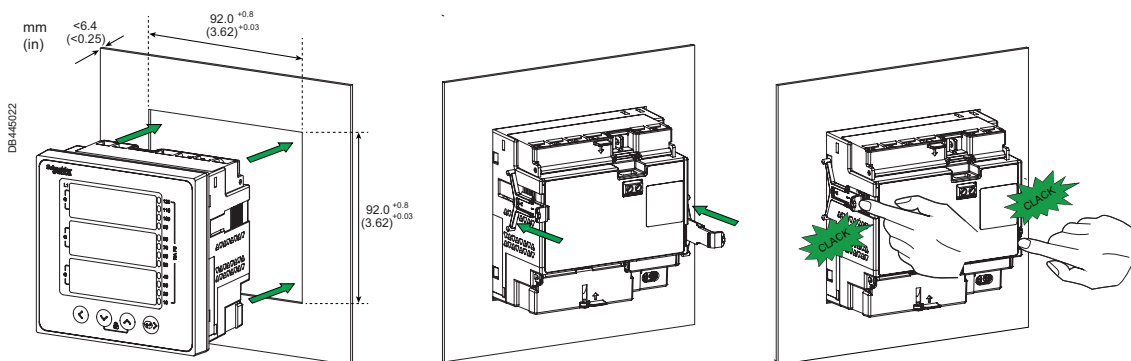

See the appropriate **Installation Guide** for correct installation instructions.

EasyLogic™

DM1000 / DM3000 Series

DM1000 series: 1-phase Volt / Amps / Frequency digital panel meters in LED display

DM3000 series: 3-phase Volt / Amps digital panel meters in LED display

Introducing EasyLogic™ DM1000/DM3000 Series meters that are ideal replacements for multiple analog meters for stand-alone metering in custom panels, switch boards, switch-gear, genset panels, motor control centres, and OEM panel board.

DM1000/DM3000 series meters offer large 7-segment numeric LED display type, intuitive navigation with self-guided 1 button, bright LED's of 14.2 mm height.

PB124324



DM1000 series

PB124325



DM3000 series

DM1000/DM3000 Series



EasyLogic™ DM1000 series front view



EasyLogic™ DM1000 series rear view



EasyLogic™ DM3000 series front view



EasyLogic™ DM3000 series rear view

Applications

- Basic Voltage, Current, Frequency parameter measurement
 - Control panels
 - Motor control centres
 - Power distribution boards
 - Original equipment manufacturers (OEM's)
 - Panel instrumentation

Main characteristics

- Easy to install: Mounts using two retainer clips. Compact meter with 43.5 mm depth behind the panel, direct measurement upto 480 V +10 % AC volts L-L without voltage transformers for installation compliant with measurement category III and double insulated
- Easy to operate: Intuitive navigation with single button for self-guided menus
- LED display: 7 segment numeric LEDs of height ~14.2 mm (0.55 in) with 4 digits display in one row with kilo value indicator
- Standard compliance:
 - EMI/EMC tests as per IEC 61326-1
 - CE certification as per IEC 61010-1 Edition 3
- Accuracy 0.5 % on full scale for Volt & Amps and 0.2 % for Frequency
- CT nominal: 5 A I-nominal or 1 A I-nominal (field settable)
- Password: For securing set up information
- Display: 4 digits for Volt / Amps / Frequency parameters with auto range features
- Panel key: Single key for programming, navigation or as selector switch
- Control power options: Universal range 44 to 275 V L-N AC/DC
- Green premium Ecolabel product

DM1000/DM3000 Series

Technical specifications

General	
Use on LV & MV systems. Potential transformer (PT or VT) / Current transformer (CT) ratio programmable at site	
Digital panel meters for measurement of Volt / Amps / Frequency electrical parameters	
Instantaneous rms values	
Current	Line current of 1-phase or per-phase of 3-phase
Voltage	Line voltage of 1-phase or per-phase of 3-phase
Frequency	1-phase
Display	
LED display: 7 segment numeric LEDs of height ~14.2 mm (0.55 in) with 4 digits display in one row with kilo value indicator	
Electrical characteristics	
Type of measurement	True RMS
Measurement accuracy (Class 0.5 meters)	
Current, per-phase	± 0.5 % of full scale
Voltage, L-N or L-L, per-phase	± 0.5 % of full scale
Frequency	± 0.2 % of full scale
Input-voltage	
Input Voltage (50/60 Hz ± 5 %)	80 to 480 V L-L ± 10 % direct, upto 999 kV with external PT/VT, Category III
Permanent overload (withstand)	600 V L-L, continuous
VA burden	≤0.2 VA at 240 V L-N at 50/60 Hz
Frequency – measurement	
Nominal operating range	20 to 100 Hz
Input Voltage (50/60 Hz ± 5 %)	80 to 480 V L-L ± 10 %
Input-current	
CT primary	Programmable
CT secondary	1 A or 5 A I-nominal (field settable)
Operating current range with accuracy	50 mA to 6 A
Permanent overload (withstand)	Continuous 10 A max., 5 s/hr 50 A, 1 s/hr 120 A
Frequency	50/60 Hz ± 5 %
VA Burden	≤0.2 VA at 5 A at 50/60 Hz
AC control power	
Operating range	48 to 250 V L-N AC ± 10 %
Burden	≤3 VA at 240 V L-N 50/60 Hz
Frequency	50/60 Hz nominal (± 5)
DC control power	
Operating range	48 to 250 Vdc ± 10 %
Burden	≤1 W at 240 Vdc
Display update	
Instantaneous/ RMS parameters	1 s
Mechanical characteristics	
Weight	DM1000 <175 gm (6.2 oz), DM3000 <220 gm (7.8 oz)
IP degree of protection	IP 51 front side, IP 30 meter body, tested as per IEC 60529
Material	Polycarbonate meets UL 94V-0 flammability rating
Dimensions WxHxD	96x96x43.5 mm (3.78x3.78x1.71 in) maximum depth of the meter from housing mounting flange and < 6 mm (0.24 in) protrusion of meter from housing flange
Mounting position	Vertical
Panel thickness	5 mm (0.196 in) maximum
Environmental characteristics	
Operating temperature	-10 to 60 °C (14 to 140 °F)
Storage temperature	- 25 to 70 °C (-13 to 158 °F)
Humidity rating	5 to 95 % RH non-condensing
Pollution degree	2
Altitude	≤2000 m (6562 ft) Category III
Product life	>7 years
Insulation category	Double insulation for user accessible parts

DM1000/DM3000 Series

Technical specifications (Continued)

Electromagnetic compatibility (tested as per IEC 61326-1)	
Electrostatic discharge	IEC 61000-4-2
Immunity to radiated field	IEC 61000-4-3
Immunity to fast transients	IEC 61000-4-4
Immunity to impulse waves	IEC 61000-4-5
Conducted immunity	IEC 61000-4-6
Immunity to magnetic fields	IEC 61000-4-8
Immunity to voltage dips	IEC 61000-4-11
Harmonic current emissions	IEC 61000-3-2
Voltage fluctuations and flicker	IEC 61000-3-3
Emissions	Emissions FCC Part 15 Class A/CE, CISPR11
Safety	
Europe	CE, as per IEC 61010-1 edition 3
Measurement Category (Voltage inputs)	Category III up to 480 V L-L
Overvoltage Category (Control power)	Category III up to 300 V L-N
Dielectric	As per IEC/UL 61010-1 edition 3
Protective Class	II, Double insulated for user accessible parts
Green premium	EOL, REACH, PEP, RoHS complied
Isolation	4 kV for 1 min
Protection/Installation Guide	
Protection features	Password for set-up
Display language	Numeric value
Technical publication	Printed installation guide (QSG) supplied with meter in English and in soft format
Human machine interface	
Display type - LED	LED display: 7 segment numeric LEDs of height ~14.2 mm (0.55 in) with 4 digits display in one row with kilo value indicator
Keypad	Panel key: Single key for programming, navigation or as selector switch

Feature set summary

Parameter	DM1110	DM1210	DM1310	DM3110	DM3210	Accuracy (in Full scale)
1-ph Amps	■					0.5 %
1-ph Volts		■				0.5 %
1-ph Hz			■			0.2 %
3-ph Amps				■		0.5 %
3-ph Volts					■	0.5 %
Commercial reference number						
Commercial reference starts with METSE***	DM1110	DM1210	DM1310	DM3110	DM3210	-

DM1000/DM3000 Series

DM1000/DM3000 Series meter installation

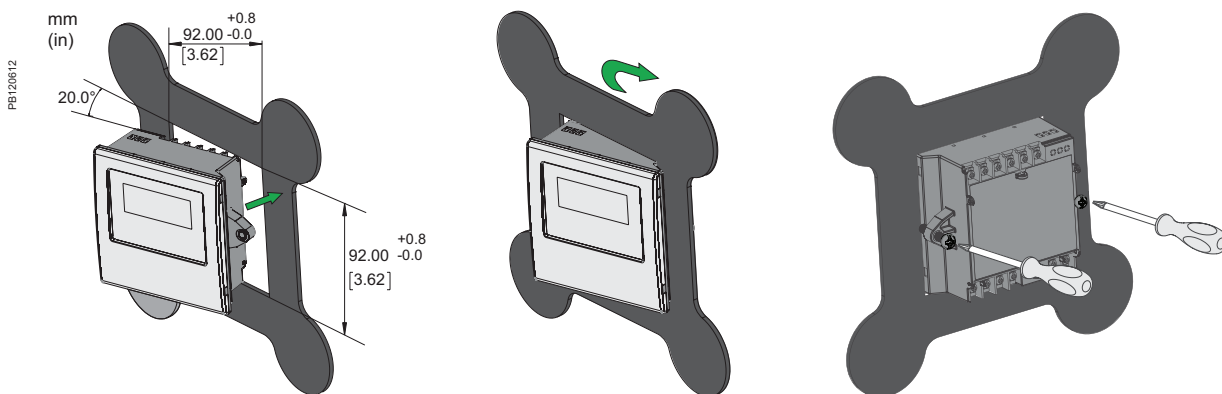

DM1000/DM3000 Series meter mechanical dimensions

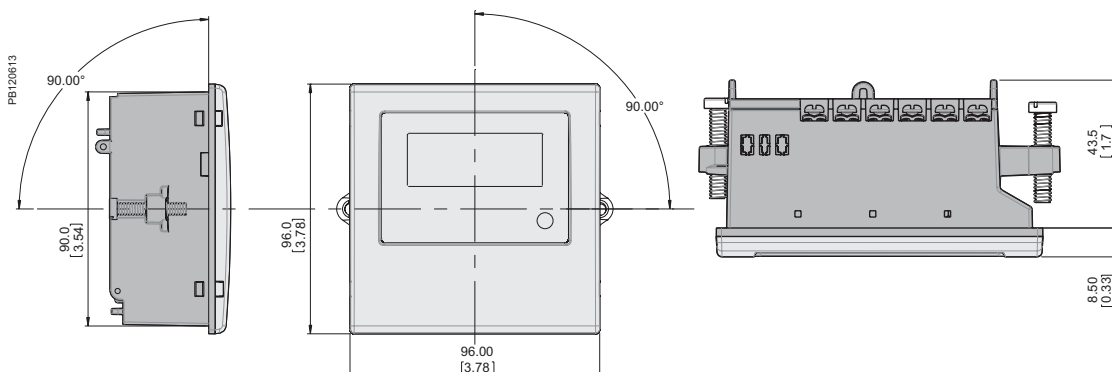

DM1000/DM3000 series meter display overview

Front Panel

DM1000 Series

DM3000 Series

Rear Panel

METSEDM1110

METSEDM1210

METSEDM1310

METSEDM3110

METSEDM3210

- A** Bright red LED display
- B** Smart LED indicators: Kilo and phase indicators
- C** Dual function key
- D** Phase LED indicator
- E** Current input terminals
- F** Auxiliary supply(control power) terminals
- G** Frequency input terminals
- H** Voltage input terminals

See the appropriate Installation Guide for correct installation instructions.

EasyLogic™ DM6xx0H Series

DM6000H & DM6200H VAF PF digital panel meters in LED display

DM6220H VAF PF digital panel meters in LCD display

Introducing EasyLogic™ DM6xx0H Series meters that are ideal replacements for multiple analog meters for stand-alone metering in custom panels, switch boards, switch-gear, genset panels, motor control centres, power factor improvement panels, and OEM panel board.

DM6xx0H series meters offer large 8-segment alpha-numeric LED display type, intuitive navigation with self-guided 4 buttons, bright LED's of 14.2 mm height with 12 LEDs for indicating percentage of load in the circuit.

DM6220H meter displays measured parameters and values in elegant single row, bright back lit graphical LCD display in 128*32 pixels size.



DM6220H series



DM6200H series

DM6xx0H Series



EasyLogic™ DM6220H front view



EasyLogic™ DM6000H front view



EasyLogic™ DM6xx0H Rear view

- Applications
 - Cost management
 - Electrical installation remote monitoring
 - Control panels
 - Motor control centres
 - Power distribution boards
 - Original equipment manufacturers (OEM's)
 - Building management system
 - Panel instrumentation
 - Energy management system
- Network management
 - Measurement of Power Factor
 - % unbalance for voltage and current
 - Phase angle between the respective voltage and current phase
 - Modbus RTU protocol, RS-485 communication port for integration with energy management systems (DM6200H & DM6220H)
- Main characteristics
 - Easy to install: Mounts using two retainer clips, no tools required. Compact meter with 49 mm meter depth behind the panel, connectable up to 480 V +10 % AC volts L-L without voltage transformers for installation complaint with measurement category III, and double insulated
 - Easy to operate: Intuitive navigation with self-guided menus and Heartbeat LED indicates normal functioning of meters while it conveys the communication status when connected to RS-485 network
 - LED display: Intuitive navigation with self-guided, four buttons, 8 segment alphanumeric LEDs of height ~14.2mm (0.55 in) and three lines of concurrent values with Kilo & Mega value indicators
 - LCD display: Elegant single row, bright back lit graphical LCD display 128*32 pixels, Fast in-line view, three parameters name and value at one glance
 - Standard compliance:
 - EMI/EMC tests as per IEC 61326-1
 - CE certification as per IEC 61010-1 Edition 3
 - cULus as per UL61010-1 and CAN/CSA-C22.2 IEC 61010-1 edition 3, for 480 Vac L-L
 - Accuracy class 1.0 for V AF PF metering
 - CT nominal: 5 A, I-nominal or 1 A, I-nominal (field settable)
 - Password: Field configurable password for securing set up information
 - Cyber security: Option for disabling RS-485 port through front panel keys against unauthorized access. This feature can also be used for maintenance and troubleshooting of complex communication network
 - Analog load bar in LED display: the colour-coded analog load bar at the front side indicates the percentage of load through 12 LED's with the option to select full scale based on connected load
 - Display: 4 digits for VAF PF parameters with auto scroll and auto range features
 - Suppression current: To disregard the measurement of induced and panel auxiliary load current in the circuit (settable from 5 to 99 mA)
 - Protection cover to ensure that terminal screws do not detach from the housing and are touch proof against fingers
 - Smart line indicators in LCD display meter: helps check the presence of input supply voltage (healthy phase)
 - Control power options: Universal range 44 to 300 V L-N AC/DC or low voltage DC control power of 9 to 36 Vdc

DM6xx0H Series

Technical specifications

General	
Use on LV & MV systems with Potential transformer (PT or VT) / Current transformer (CT) ratio programmable at site	
Digital panel meters for measurement of basic electrical parameters	
Instantaneous rms values	
Current	Average line current of 3-phase, per-phase, and calculated neutral current
Voltage	Average voltage of L-L, L-N parameters, and per-phase
Frequency	Any available line
True power factor	Average and per-phase signed
Unbalance	Maximum % unbalance among phases for Volts & Amps
Revolution per minute (RPM)	RPM of alternator or generator when number of poles set for 2, 4, 6, 8, 12, 14 or 16 (any one pole)
Life timer stored in non-volatile memory	
Time counters for measuring meter ON Hrs and power interruptions	
Display	
LED display: Bright red colour, 8 segment alphanumeric LED, ~ 14.2 mm (0.55 in) height, 3 rows with 4 digits per row, auto range, auto scroll	
LCD display: Elegant single row, bright back lit graphical LCD display 132 (Horizontal) * 32 (Vertical) pixels, 60 Degree angular view. Fast in-line view, three parameters name and value at one glance	
Communication	
RS-485 serial (DM6200H)	Channel connection Industry standard Modbus RTU protocol
Integration with software	Any Modbus compatible SCADA/DCS/PMS/EMS/BAS/BMS software
Native Plug and Play support	Schneider Electric energy management system software - EcoStruxure™ Power Monitoring Expert, EcoStruxure™ Power Operation ION Setup utility software for set-up/programming of meters
Diagnostics	
Diagnostic page	Diagnostic page indicates the healthiness of communication system, device serial number, device model number OS & RS version, communication status All LED segment check in LED display. In LCD display meter - alternate pixels ON/ OFF test. LCD contrast level, set back-lit time out in the range of 1 to 99 sec
Lock / Un-Lock	
Page lock and unlock features	Once the commonly referred page is enabled for lock feature, the display returns to locked page in 4 minutes of inactive time
Electrical characteristics	
Type of measurement	True RMS, 32 samples/cycle
Measurement accuracy (Class 1.0 meters)	
Current, per-phase & average	± 0.5 % of reading
Voltage, L-N, L-L, per-phase & average	± 0.5 % of reading
Power factor, per-phase & average	± 0.01 of reading
Frequency	± 0.05 % for F-nominal 50/60 Hz ± 2 ± 0.2 % for Frequency range from 30 to 48 Hz, 52 to 58 Hz and 62 to 70 Hz
Input-voltage	
VT (PT) connection	Selectable from No VT (direct), 1 VT, 2 VT to 3 VT
VT (PT) primary	100 V L-L to 999 kV L-L max
U (V) nominal	Up to 277 V L-N/ 480 V L-L (selectable VT secondary from 100, 110, 115, 120 to 415 V L-L)
Operating voltage range with accuracy	80-480 V L-L ± 10 % Category III
Measured Voltage with full range	35 to 600 V L-L
Permanent overload (withstand)	750 V L-L, continuous
Impedance	≥5 MΩ
Frequency	50/60 Hz ± 2
VA burden	≤0.2 VA at 240 V L-N at 50 Hz
Frequency – measurement	
Nominal operating range	50/60 Hz ± 2
Extended operating range	30 to 48 Hz, 52 to 58 Hz and 62 to 70 Hz
Voltage input	80 to 480 V L-L ± 10 %
Input-current	
CT connect	Solo or multi-phase current measurement by installing CT (s) in either of A1, A2, A3, A12, A23, A13, A123 phase(s)
CT primary	1 A to 32767 A, programmable
CT secondary	1 A or 5 A I-nominal (field settable)
Operating current range with accuracy	10 mA to 6 A ⁽⁺¹⁾
Measured Amps with over range & Crest Factor	5 mA to 10 A
Suppression current	5 to 99 mA (to disregard negligible load)
Impedance	< 0.3 mΩ
Permanent overload (withstand)	Continuous 10 A, 10 s/hr 50 A, 1 s/hr 500 A
Frequency	50/60 Hz ± 2
VA Burden	≤0.1 V A at 5 A at 50 Hz

(+1) Additional error of ± 2 % between 10 mA to 50 mA, ± 1 % between 50 mA to 100 mA

DM6xx0H Series

Technical specifications (continued)

AC control power	
Operating range	48 to 277 V L-N AC ± 10 %
Burden	≤4 VA at 240 V L-N 50 Hz
Frequency	50/60 Hz nominal (45 to 65 Hz operating range)
Ride-through time	200 milliseconds at 240 V L-N, 50 Hz
DC control power	
Operating range	48 to 277 Vdc ± 10 % or Low Voltage DC option of 10 to 32 Vdc ± 10 % for DM6220H
Burden	≤2 W at 240 Vdc, <2 W at 24 Vdc
Ride-through time	120 ms at 240 V
Displays update	
Instantaneous/ RMS parameters	1 s
Power system	
Phase labelling	Configurable to 123, ABC, rst, pqr or ryb
Wiring configuration	13 wiring schemes (5 on front screen) 1ph, 2w, L-N 1ph, 2w, L-L 1ph, 3w, L-L with N (2-phase) 3ph, 3w, Delta, Ungrounded 3ph, 3w, Delta, Corner Grounded ⁽⁺²⁾ 3ph, 3w, Wye, Ungrounded ⁽⁺²⁾ 3ph, 3w, Wye Grounded ⁽⁺²⁾ 3ph, 3w, Wye, Resistance Grounded ⁽⁺²⁾ 3ph, 4w, Open Delta, Centre-Tapped ⁽⁺²⁾ 3ph, 4w, Delta, Centre-Tapped ⁽⁺²⁾ 3ph, 4w, Wye, Ungrounded ⁽⁺²⁾ 3ph, 4w, Wye Grounded 3ph, 4w, Wye, Resistance Grounded ⁽⁺²⁾
Mechanical characteristics	
Weight	~ 300 gm (10.6 oz)
IP degree of protection	IP 51 front side, IP 30 meter body, tested as per IEC 60529 (IP 54 with optional gasket METSEIP54GK96X96FF or upgrade to IP65 front side with Optional accessory kit METSEIP65OP96X96FF)
Material	Polycarbonate meets UL 94V-0 flammability rating
Dimensions WxHxD	96x96x49 mm (3.78x3.78x1.93 in) maximum depth of the meter from housing mounting flange and 13 mm (0.51 in) protrusion of meter from housing flange
Mounting position	Vertical
Panel thickness	5 mm (0.196 in) maximum
Environmental characteristics	
Operating temperature	-10 to 60 °C (14 to 140 °F)
Storage temperature	-20 to 70 °C (-4 to 158 °F)
Humidity rating	5 to 95 % RH non-condensing
Pollution degree	2
Altitude	≤2000 m (6562 ft) Category III
Product life	>7 years
Insulation category	Double insulation for user accessible parts
Electromagnetic compatibility (tested as per IEC 61326-1)	
Electrostatic discharge	IEC 61000-4-2
Immunity to radiated field	IEC 61000-4-3
Immunity to fast transients	IEC 61000-4-4
Immunity to impulse waves	IEC 61000-4-5
Conducted immunity	IEC 61000-4-6
Immunity to magnetic fields	IEC 61000-4-8
Immunity to voltage dips	IEC 61000-4-11
Emissions	Emissions FCC Part 15 Class A/CE

⁽⁺²⁾ Through communication

DM6xx0H Series

Technical specifications (continued)

Safety	
Europe	CE, as per IEC 61010-1 edition 3
US and Canada	cULus as per UL61010-1 and CAN/CSA-C22.2 IEC 61010-1 edition 3, for 480 V L-L
Measurement Category (Voltage inputs)	CAT III up to 480 V L-L
Overvoltage Category (Control power)	CAT III up to 300 V L-N
Dielectric	As per IEC/UL 61010-1 edition 3
Protective Class	II, Double insulated for user accessible parts
Green premium	EOL, REACH, PEP, RoHS complied
Other certification	RCM & EAC for Russia
Communication	
RS-485 port	Modbus RTU: 2-Wires, with ground & shield, 4800, 9600, 19200 or 38400 baud, Parity - Even, Odd, None, 1 stop bit if parity is Odd or Even, 2 stop bits if None DLF3000: Firmware update through communication port
Isolation	2.5 kV RMS, double insulated
Protection features	User configurable password (selectable from 0000 to 9999) protected for set-up
Display language	English
Technical publication	Printed installation guide (QSG) supplied with meter in multi-language (EN, ES, FR, DE, PT, RU, TR, ZH) and user guide in soft format
Human machine interface	
Display type - LED	8 segment Alpha-numeric LED, ~ 14.2 mm (0.55 in) height, 3 rows with 4 digits per row, 1 column of 12 LEDs to indicate percentage of load connected in system. 4 digits for VAF PF parameters, with auto scrolling and auto range
Display type - LCD	Fast in-line view, three parameters name and value at one glance. 3+1 digits for instantaneous parameters with auto range
Keypad	4 buttons for navigation at the front, combination of 2 buttons for lock/unlocking of commonly viewed page
Communication activity	Green LED (for indicating RS-485 interface or heartbeat pulse)

Feature set summary

Parameter	DM6000H Class 1.0	DM6200H Class 1.0	DM6220H Class 1.0
V A F – per-phase & Average	■	■	■
PF – per-phase & Average	■	■	■
% Load, % V & I Unbalance, Ph-angle, RPM	■	■	■
Modbus RS-485	-	■	■
Sampling rate per cycle	32	32	32
Amps: per-phase & Average, calculated neutral current	■	■	■
Voltage: V L-N, V L-L, per-phase & Average	■	■	■
Power factor: per-phase & Average	■	■	■
Frequency: any available phase	■	■	■
Revolutions per minute (RPM)	■	■	■
Phase angle : Amp Deg (V to Amps, per-phase)	■	■	■
% Unbalance: Maximum of 3-ph V and Amps	■	■	■
Life time counter - meter ON Hrs and number of power interruptions	■	■	■
Communication: RS-485, Modbus RTU protocol	-	■	■
Display Type	LED	LED	LCD
Commercial reference numbers			
Commercial reference for 44 - 300 Vac/dc control power	METSEDM6000HCL10NC (Cl 1.0)	METSEDM6200HCL10RS (Cl 1.0)	METSEDM6220HCL1 (Cl 1.0)
Commercial reference for Low Voltage DC (9-36 V) option			METSEDM6220HCL1LVD (Cl 1.0)

DM6xx0H Series

DM6220H Series meter mounting

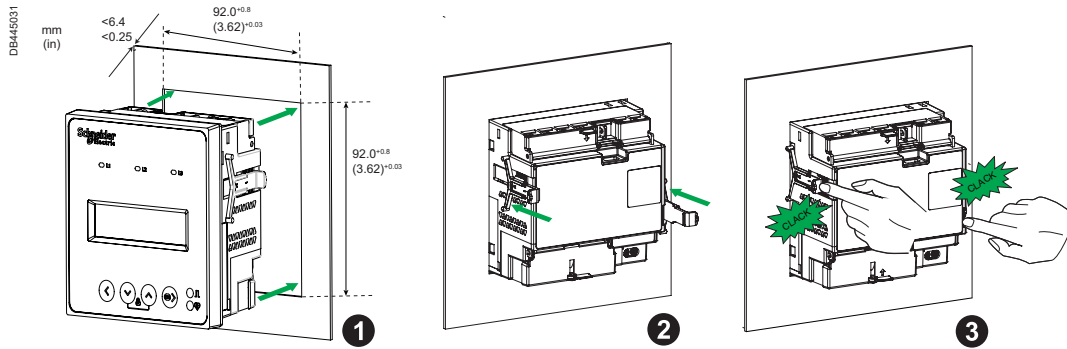

DM6220H Series meter mechanical dimensions

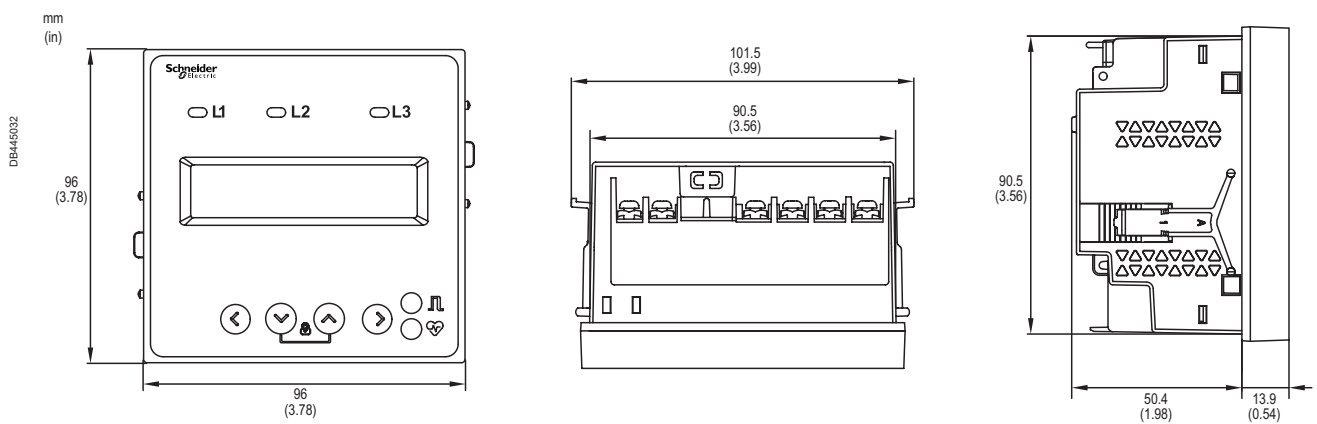

DM6000H Series meter mounting

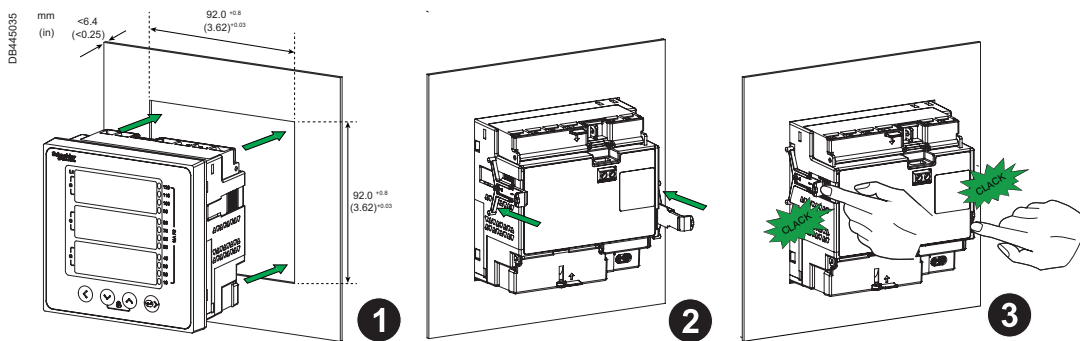

DM6000H Series meter mechanical dimensions

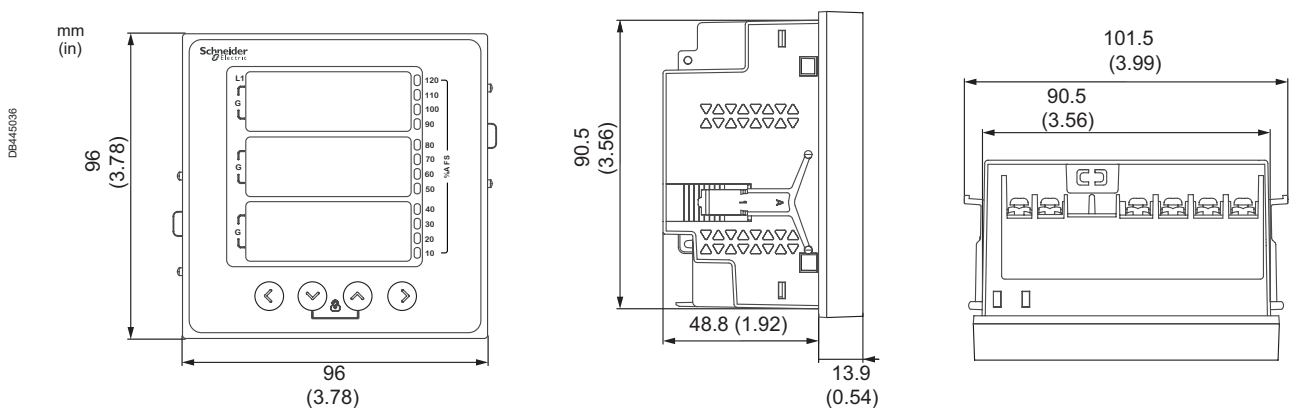

DM6xx0H Series

DM6000H/DM6220H meter display overview

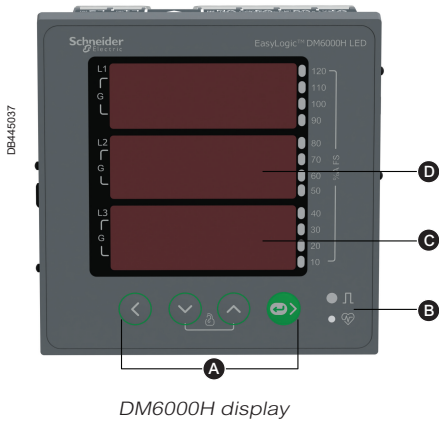

DM6000H display

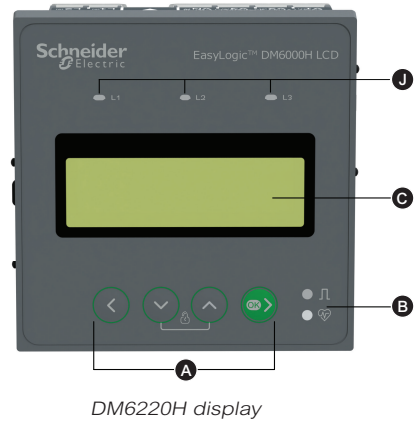

DM6220H display

- A** Menu selection buttons
 - ◀ Left key: To navigate left
 - ▼ Down key: To navigate down
 - ▲ Up key: To navigate up
 - ▶ Right/OK key: To navigate right/Enter key
- B** LED indicators
 - Red: Pulse
 - Green: Heartbeat
- C** Alpha numeric LED/ LCD display
- D** Analog load bar
- E** Current inputs
- F** RS-485 port (DM6200H only)
- G** Retainer clip
- H** Control power
- I** Voltage inputs
- J** Voltage line indicators



Rear view for DM6000H and DM6220H

See the appropriate **Installation Guide** for correct installation instructions.

IP65 Accessory Kit

Upgrade IP degree of protection against ingress of dust and water for panel meters with optional IP65 accessory kit. Compatible with Schneider make power meter models: DM6000, EM1000, DM6xx0H, EM1000H, EM64xxH, EM6400NG+, EM7200, PM1000H, PM2000, PM5000 series.

IP – Ingress protection rating is used to specify the environmental protection of electrical equipment Ingress Protection (IP) ratings are developed by the European Committee for Electro Technical Standardization (CEN/IEC), to specify the environmental protection on the device enclosures. The applicable standard for testing IP degree of protection of the device is IEC 60529.

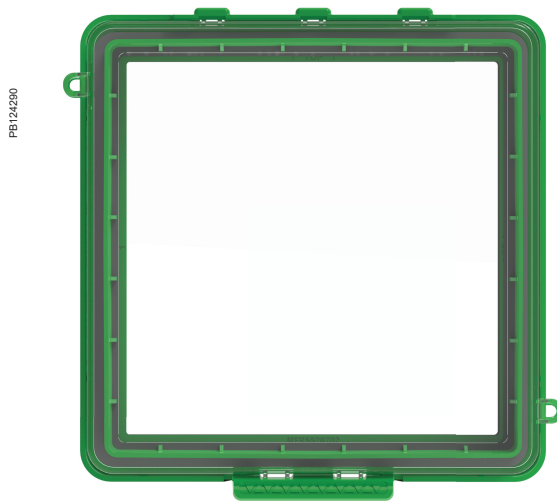

IP65 accessory kit



Power meter upgraded to IP65 degree of protection

IP65 Accessory Kit

PEI124292



IP65 Accessory Kit iso view

- Applications
 - Upgrade Ingress protection of power meters to IP65 level
 - Specific electrical panels require higher degree of ingress protection against the penetration of dust and water
 - Mines, Minerals and Metals
 - FMCG, Food and Beverages
 - Outdoor panels
 - Substation
 - RMU (Ring Main Unit)
 - Generators
 - Panel instrumentation
 - Optional accessory for PowerLogic™ PM5000 series and EasyLogic™ DM6000, EM1000, DM6xx0H, EM1000H, EM64xxH, EM6400NG+, EM7200, PM1000H, PM2000 series power meter

- Main characteristics
 - IP65 enclosure kit for 96mmx96 mm form factor power meters with bezel thickness of maximum 15 mm
 - CE compliant
 - Field upgradable
 - Sealing provision against tampering of meter data
 - Clear transparent view of the meter display
 - Easy to operate with one click snap button
 - IP65 certified as per IEC 60529 standard
 - Tested for flammability as per UL 94

Commercial reference number

Commercial reference number	Description
METSEIP65OP96X96FD	IP65 Accessory kit for 96x96 mm form factor power meter (for India)
METSEIP65OP96X96FF	IP65 Accessory kit for 96x96 mm form factor power meter (for global)

IP65 Accessory Kit Technical Specifications

Environmental characteristics	
Operating temperature	-25 to 70 °C (-13 to 158 °F)
Storage temperature	- 30 to 80 °C (-22 to 175 °F)
Humidity rating	5 to 95 % RH non-condensing
Altitude	≤3000 m (9842.5 ft)
RoHS compliance	2015/863/EU
General	
IP protection degree	IP65 as per IEC 60529
Weight	0.07 kg/part
Flammability rating according to UL 94	V2 grade
Sealing hole	Ø2.0 mm (Ø0.08 in)

IP degree rating table

First number:	Protection against:	Second number:	Protection against:
0	No protection	0	No protection
1	Solid objects greater than 50 mm	1	Vertical water drops to which indoor equipment can be exposed due to leaks or condensation, limited ingress permitted
2	Solid objects greater than 12 mm	2	Direct sprays of water up to 15° from the vertical, limited ingress permitted
3	Solid objects over 2.5 mm (tools and wires)	3	Direct sprays of water up to 60° from the vertical, limited ingress permitted
4	Solid objects over 1 mm (tools, wire, and small wires)	4	Water sprayed from all directions, limited ingress permitted
5	Dust limited ingress (no harmful deposit, 2 to 8 hrs)	5	Low pressure jets of water from all directions, limited ingress permitted
6	Dust, no ingress of dust, 2 to 8 hrs	6	Low pressure jets of water, limited ingress permitted
		7	The effect of immersion between 15 cm and 1 m for 30 mins
		8	Long periods of immersion under pressure

IP65 Accessory Kit

IP65 accessory kit mechanical dimensions

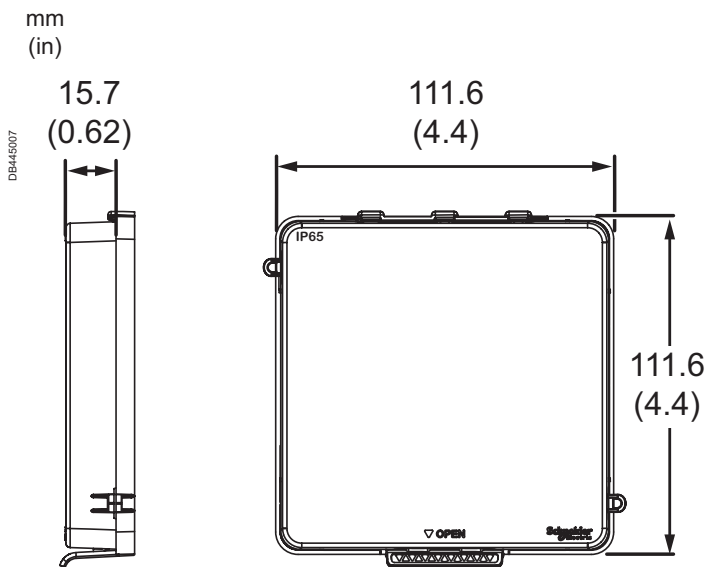

Compatible Schneider power meter ranges

Range	Power meter series
PowerLogic™	PM5000 series
EasyLogic™	DM6000 / EM1000
	DM6xx0H
	EM1000H
	EM64xxH
	EM6400NG+
	EM7200
	PM1000H
	PM2000 series

Note: See the appropriate Technical Datasheets of power meter series for more information.

IP65 accessory kit description

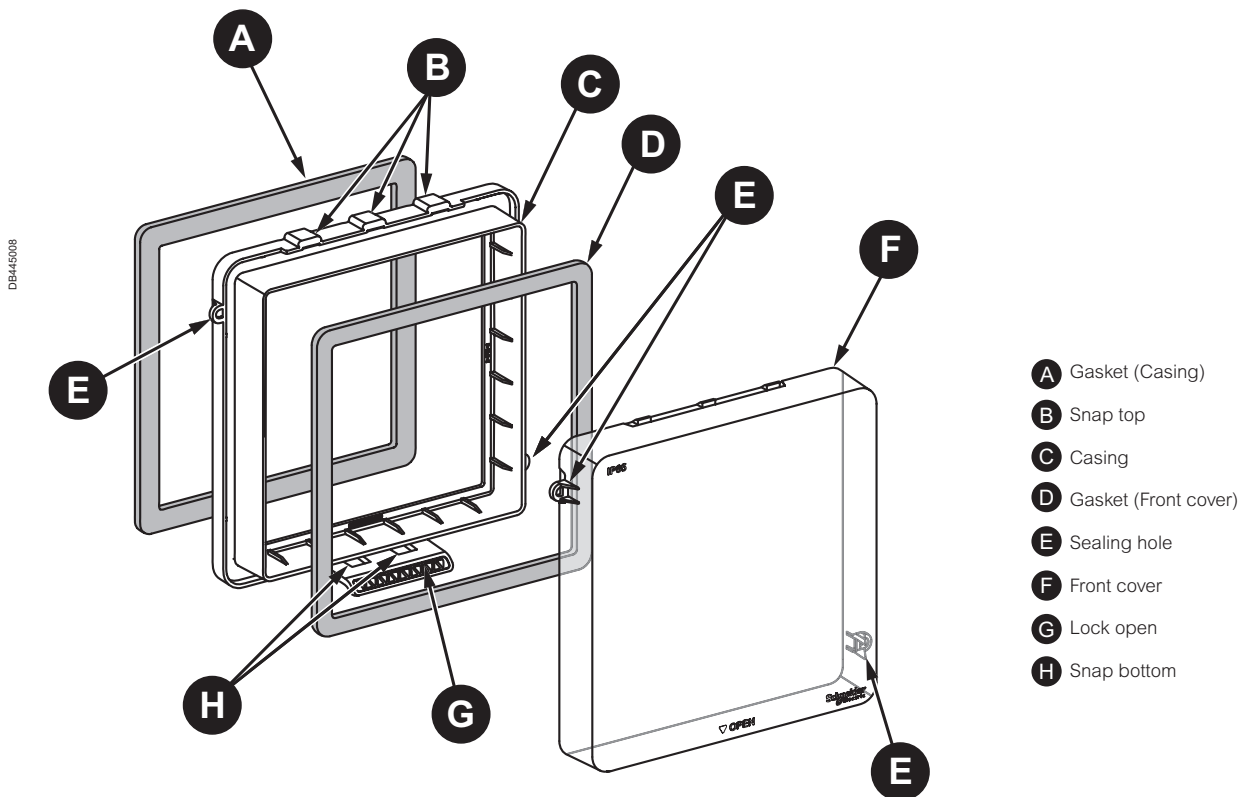

IP54 Gasket

Upgrade IP degree of protection against ingress of dust and water for panel meters with optional IP54 Gasket. Compatible with Schneider make power meter with 96 mmx96 mm form factor/dimension.

IP – Ingress protection rating is used to specify the environmental protection of electrical equipment Ingress Protection (IP) ratings are developed by the European Committee for Electro Technical Standardization (CEN/IEC), to specify the environmental protection on the device enclosures. The applicable standard for testing IP degree of protection of the device is IEC 60529.



IP54 Gasket



Power meter upgraded to IP54 degree of protection

IP54 Gasket

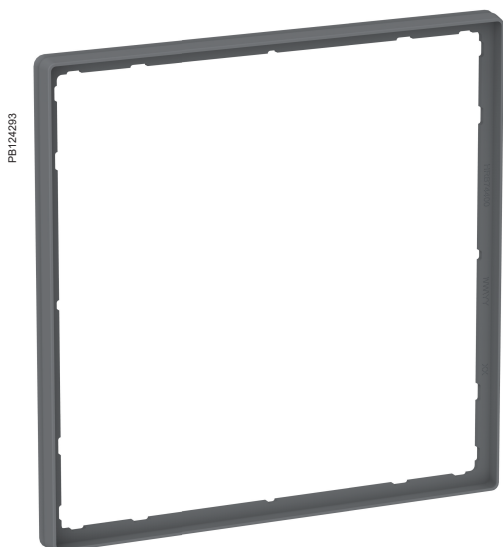

IP54 Gasket iso view

- Applications
 - Upgrade Ingress protection of power meters to IP54 level
 - Power meters in the electrical panels require higher degree of ingress protection against the penetration of dust and water
 - Add-on accessory for EasyLogic™ PM2000 series and PowerLogic™ PM5000 series power meter
 - Optional accessory for EasyLogic™ DM1000, DM3000, DM6000, EM1000, DM6xx0H, EM1000H, EM64xxH, EM6400NG+, EM7200, PM1000H series power meter
- Main characteristics
 - Compatible to use with 96 mm x 96 mm form factor power meters having cut out size of 90 mm x 90 mm ±2
 - High grade Wacker Silicones LR 3003\70 to withstand against harsh environmental conditions
 - Color: Pantone Cool Grey 11C
 - Ensures IP54 degree of protection to the power meters installed in the electrical panel
 - Long life (>15 years)
 - Easy to upgrade
 - IP54 certified as per IEC 60529 standard
 - Tested for flammability as per UL 94

Commercial reference number

Commercial reference number	Description
METSEIP54GK96X96FD	IP54 gasket for 96 mm x 96 mm form factor power meter (for India)
METSEIP54GK96X96FF	IP54 gasket for 96 mm x 96 mm form factor power meter (for global)

IP54 Gasket Technical Specifications

Environmental characteristics	
Operating temperature	-25 to 70 °C (-13 to 158 °F)
Storage temperature	- 30 to 80 °C (-22 to 175 °F)
Humidity rating	5 to 95 % RH non-condensing
Altitude	≤3000 m (9842.5 ft)
RoHS compliance	2002/95/EC
General	
IP protection degree	IP54 as per IEC 60529
Weight	< 0.02 kg/part
Flammability rating according to UL 94	HB grade

IP degree rating table

First number:	Protection against:	Second number:	Protection against:
0	No protection	0	No protection
1	Solid objects greater than 50 mm	1	Vertical water drops to which indoor equipment can be exposed due to leaks or condensation, limited ingress permitted
2	Solid objects greater than 12 mm	2	Direct sprays of water up to 15° from the vertical, limited ingress permitted
3	Solid objects over 2.5 mm (tools and wires)	3	Direct sprays of water up to 60° from the vertical, limited ingress permitted
4	Solid objects over 1 mm (tools, wire, and small wires)	4	Water sprayed from all directions, limited ingress permitted
5	Dust limited ingress (no harmful deposit, 2 to 8 hrs)	5	Low pressure jets of water from all directions, limited ingress permitted
6	Dust, no ingress of dust, 2 to 8 hrs	6	Low pressure jets of water, limited ingress permitted
		7	The effect of immersion between 15 cm and 1 m for 30 mins
		8	Long periods of immersion under pressure

IP54 Gasket

IP54 gasket mechanical dimensions

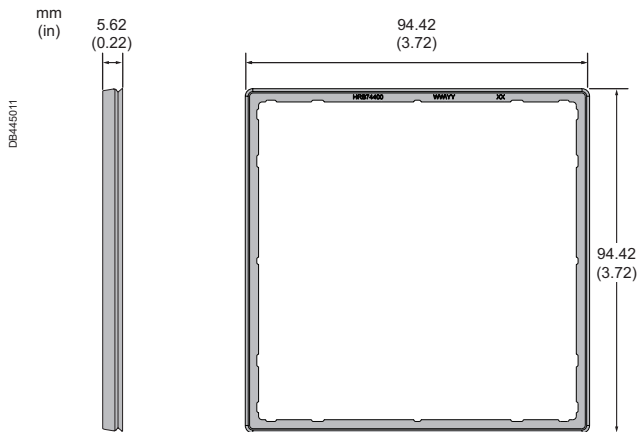

Compatible Schneider power meter ranges

Range	Power meter series
PowerLogic™	PM5000 series
EasyLogic™	DM1000 / DM3000
	DM6000 / EM1000
	DM6xx0H
	EM1000H
	EM64xxH
	EM6400NG+
	EM7200
	PM1000H
	PM2000 series

Note: See the appropriate Technical Datasheets of power meter series for more information.

IP54 gasket Mounting

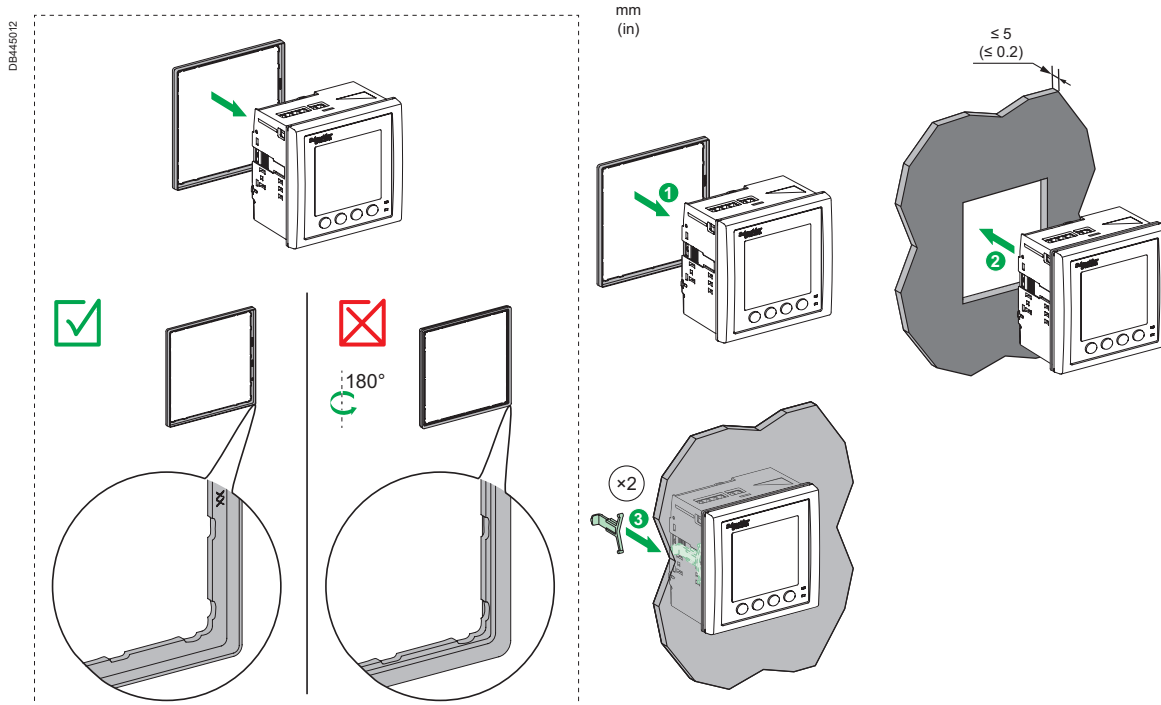

IP54 gasket Dismounting

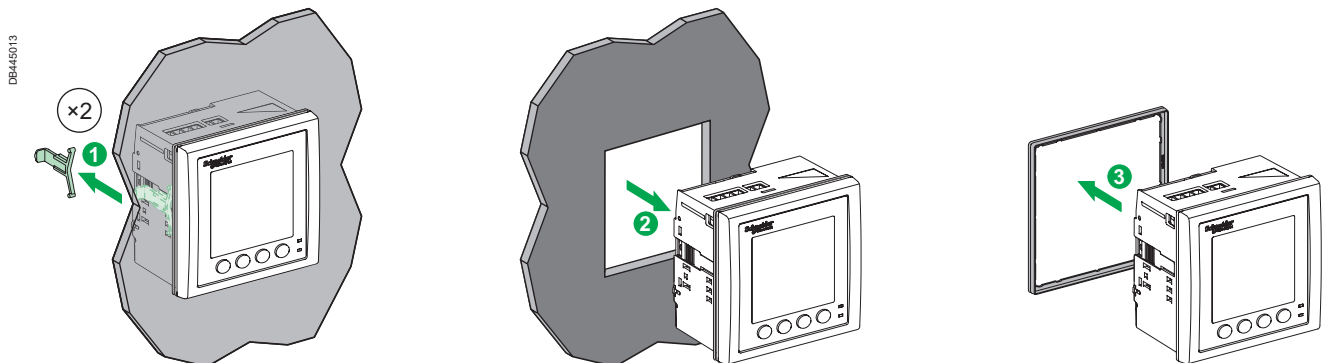

See the appropriate Installation Guide for correct installation instructions.

EasyLogic™ Commercial Reference Numbers

Comm. reference number	Description
PM2000 series	
METSEPM2110	PM2110 CI 1.0 Pulse output power and energy meter LED display
METSEPM2120	PM2120 CI 1.0 RS-485 power and energy meter LED display
METSEPM2125C2AI2AO	PM2125C CI 0.5S RS-485 power and energy meter 2-AI 2-AO LED display
METSEPM2125C2DI2RO	PM2125C CI 0.5S RS-485 power and energy meter 2-DI 2-RO LED display
METSEPM2130	PM2130 CI 0.5S RS-485 CI power and energy meter LED display
METSEPM2210	PM2210 CI 1.0 Pulse output power and energy meter LCD display
METSEPM2220	PM2220 CI 1.0 RS-485 power and energy meter LCD display
METSEPM2225C2AI2AO	PM2225C CI 0.5S RS-485 power and energy meter 2-AI 2-AO LCD display
METSEPM2225C2DI2RO	PM2225C CI 0.5S RS-485 power and energy meter 2-DI 2-RO LCD display
METSEPM2230	PM2230 CI 0.5S RS-485 CI power and energy meter LCD display
PM2000 IO Modules - site configurable	
METSEPM2KDGTLIO22	PM2x30 Digital IO Module with 2 channels each
METSEPM2KANLGIO22	PM2x30 Analog IO module with 2 channels each
METSEPM2KANLGIO11	PM2x30 Analog IO module with 1 channel each
METSEPM2K2DI2RO	PM2x30 Digital Input and Relay Output Module with 2 channels each
PM2000R series	
METSEPM2220R	PM2220R CI 1.0 RS-485 power and energy meter RSJ45 LVCT LCD display
PM2200R series	
LVCT Solid 3 in 1 RJ45	
METSECTV35006	LVCT Solid core 3 in 1 with RJ45 cable, 35 mm phase center, 60 Amps, 0.333V output, Class 1.0
METSECTV35010	LVCT Solid core 3 in 1 with RJ45 cable, 35 mm phase center, 100 Amps, 0.333V output, Class 1.0
METSECTV35013	LVCT Solid core 3 in 1 with RJ45 cable, 35 mm phase center, 125 Amps, 0.333V output, Class 1.0
METSECTV35016	LVCT Solid core 3 in 1 with RJ45 cable, 35 mm phase center, 160 Amps, 0.333V output, Class 1.0
METSECTV35020	LVCT Solid core 3 in 1 with RJ45 cable, 35 mm phase center, 200 Amps, 0.333V output, Class 1.0
METSECTV35025	LVCT Solid core 3 in 1 with RJ45 cable, 35 mm phase center, 250 Amps, 0.333V output, Class 1.0
METSECTV45025	LVCT Solid core 3 in 1 with RJ45 cable, 45 mm phase center, 250 Amps, 0.333V output, Class 1.0
Cables	
DCEPCURJX5GYM	Category 5e, Patch Cord, UTP, 0.5 M, Grey
DCEPCURJ01GYM	Category 5e, Patch Cord, UTP, 1 M, Grey
DCEPCURJ02GYM	Category 5e, Patch Cord, UTP, 2 M, Grey
DCEPCURJ03GYM	Category 5e, Patch Cord, UTP, 3 M, Grey
DCEPCURJ05GYM	Category 5e, Patch Cord, UTP, 5 M, Grey
DCEPCURJ10GYM	Category 5e, Patch Cord, UTP, 10 M, Grey
EM1000H	
METSEEM1250HCL1	EM1250H CI 1.0 RS-485 energy meter LCD display
METSEEM1220HCL1	EM1220H CI 1.0 RS-485 energy meter LCD display
METSEEM1220HCL5	EM1220H CI 0.5 RS-485 energy meter LCD display
METSEEM1220HCL5LVD	EM1220H CI 0.5 RS-485 energy meter LCD display LVDC control power
PM1000H series	
METSEPM1120HCL10RS	PM1120H CI 1.0 RS-485 power meter LED display
METSEPM1120HCL05RS	PM1120H CI 0.5 RS-485 power meter LED display
METSEPM1125HCL10RS	PM1125H CI 1.0 RS-485 multi-function power meter LED display
METSEPM1125HCL05RD	PM1125H CI 0.5 RS-485 multi-function power meter LED display
METSEPM1125HCL1LVD	PM1125H CI 1.0 RS-485 multi-function power meter LED display LVDC control power
METSEPM1125HCL5LVD	PM1125H CI 0.5 RS-485 multi-function power meter LED display LVDC control power
METSEPM1225HCL1	PM1225H CI 1.0 RS-485 multi-function power meter LCD display
METSEPM1225HCL5	PM1225H CI 0.5 RS-485 multi-function power meter LCD display

Please contact your Schneider Electric representative for complete ordering information.

EasyLogic™ Commercial Reference Numbers (contd.)

Comm. reference number	Description
METSEPM1225HCL1LVD	PM1225H CI 1.0 RS-485 multi-function power meter LCD display LVDC control power
METSEPM1225HCL5LVD	PM1225H CI 0.5 RS-485 multi-function power meter LCD display LVDC control power
PM1130H / PM1230H series	
METSEPM1130HCL05RS	PM1130H CI 0.5 RS-485 dual source energy meter LED display
METSEPM1230HCL1	PM1230H CI 1.0 RS-485 dual source energy meter LCD display
METSEPM1230HCL5	PM1230H CI 0.5 RS-485 dual source energy meter LCD display
METSEPM1230HCL5LVD	PM1230H CI 0.5 RS-485 dual source energy meter LCD display LVDC control power
PM1140H	
METSEPM1140HCL1	PM1140H Power meter Class 1.0 RS485
METSEPM1140HCL5	PM1140H Power meter Class 0.5 RS485
DM1000 series	
METSEDM1110	DM1110 Class 0.5 1-phase Ammeter
METSEDM1210	DM1210 Class 0.5 1-phase Voltmeter
METSEDM1310	DM1310 Class 0.2 1-phase Frequency meter
DM3000 series	
METSEDM3110	DM3110 Class 0.5 3-phase Ammeter
METSEDM3210	DM3210 Class 0.5 3-phase Voltmeter
DM6xx0H series	
METSEDM6000HCL10NC	DM6000H Class 1.0 VAF PF meter LED display
METSEDM6200HCL10RS	DM6200H Class 1.0 RS-485 VAF PF meter LED display
METSEDM6220HCL1	DM6220H Class 1.0 RS-485 VAF PF meter LCD display
METSEDM6220HCL1LVD	DM6220H Class 1.0 RS-485 VAF PF meter LCD display LVDC control power
IP65 Accessory kit	
METSEIP65OP96X96FD	IP65 Accessory kit for 96x96 mm form factor power meter (for India)
METSEIP65OP96X96FF	IP65 Accessory kit for 96x96 mm form factor power meter (for global)
IP54 Gasket	
METSEIP54GK96X96FD	IP54 gasket for 96 mm x 96 mm form factor power meter (for India)
METSEIP54GK96X96FF	IP54 gasket for 96 mm x 96 mm form factor power meter (for global)

Please contact your Schneider Electric representative for complete ordering information.



www.se.com

Schneider Electric Industries SAS
35, Rue Joseph Monier
CS 30323
92506 Rueil Malmaison Cedex

RCS Nanterre 954 503 439
Capital social 928 298 512 €
www.se.com

February 2026
EasyLogic™ Power Metering Range Catalog
PLSED310053EN

As standards, specifications and designs develop from time to time, please ask for confirmation of the information given in this document.

© 2026 - Schneider Electric. All rights reserved.
All trademarks are owned by Schneider Electric Industries SAS or its affiliated companies.