

Acti 9 iEM3000 Series Technical Datasheet

The Acti 9 iEM3000 series energy meters is a cost-attractive, feature-rich energy metering offer for DIN rail, modular enclosures. With Modbus, BACnet, M-Bus and LonWorks protocol support, you can easily integrate these meters into commercial and non-critical buildings to add simple energy management applications to any BMS, AMR or EMS system.

Applications

Cost management applications

- Bill checking to verify that you are only charged for the energy you use.
- Sub-billing individual tenants for their energy consumption, including WAGES.
- Aggregation of energy consumption, including WAGES, and allocating costs per area, per usage, per shift, or per time within the same facility.

Network management applications

- Basic metering of electrical parameters to better understand the behaviour of your electrical distribution system.

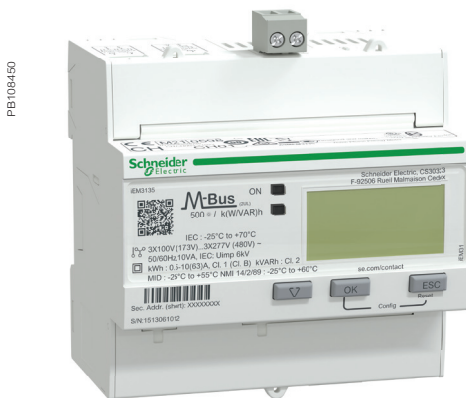

PB108450



A9MEM3135



PB113704



A9MEM3355



PB113705



A9MEM3255

More than just kWh meters, the Acti 9 iEM3000 series meters provide a full view of both energy consumption and on-site generation with full four-quadrant measurement of active and reactive energy delivered and received. Additionally, extensive real-time measurements (V, I, P, PF) give customers greater detail on their energy usage, and multiple tariffs give customers the flexibility to match the billing structure of their utility.

The solution for

All markets that can benefit from a solution that includes PowerLogic™ iEM3000 series meters:

- Buildings & industry
- Data centres and networks
- Infrastructure (airports, road tunnels, telecom)

Benefits

Optimise your energy consumption & enable energy efficiency practices:

- Collect and analyse energy consumption data from each area for each type of load or circuit
- Gain an accurate understanding of business expenses by allocating the energy-related costs
- Identify energy savings opportunities and monitor continuously
- Use information to implement actions designed to reduce energy consumption

Monitor the energy consumption of your tenants or customers and establish accurate invoices:

- Drive energy-efficient behaviour
- Allow building owners to bill tenants for individual measured utility usage
- Give accurate and achievable objectives for energy savings

Features

- Multi-line circuit: Measure individual phase energy in three phase network system
- Partial and Total energy: Separate counters for measuring active, reactive and apparent energy
- 4 Quadrant measurement: For measuring quadrant based power and energy
- Multi tariff energy: Upto 4 counters activated through RTC, digital inputs or command register
- Digital input/output: For status monitoring/tariff control and energy pulsing/overload alarm
- Demand measurement: Per-phase and average current, total power for active, reactive and apparent
- Current: Direct connected/ whole current with the option of 63 A or 125 A, 1 A or 5 A CT operated, LVCT or Rogowski coil supported
- Internal clock: Quartz crystal based back up by super capacitor

Competitive advantages

- Compact size
- MID compliant for Wh and VARh (selected models) providing certified accuracy and data security
- Programmable digital inputs/outputs
- Multi-tariff capability
- Onboard Modbus, LonWorks, M-Bus or BACnet communication*
- Baud Rate configurable
- Communication protection: enable or disable through communication
- A complete range of energy meters
- Compatible with Acti 9 range
- Direct connect upto 125 A
- Password: configurable from 0-9999*
- Pulse output*: configurable pulse constant (imp/kWh, imp/kVARh), pulse width (ms)

Energy management system:

To get the most effective use from your Schneider Electric measurement and metering devices, we offer a range of dedicated data loggers and gateways for your building energy management.

Conformity of standards*

- BS / EN / IEC 61557-12
- EN / IEC 62053-21
- EN / IEC 62053-22
- EN / IEC 62053-23
- EN 50470-3
- EN 50470-1
- METAS
- EN / IEC 62052-11
- BS / EN / IEC 61326-1
- EN / IEC 62052-31:2015
- BS / IEC / EN / UL 61010-1
- ANSI C12.20 / ANSI C12.16
- NMI M 6-1, RCM
- UL, CE and UKCA certified
- CAN/CSA-C22.2
- EAC, KZ

* Available in selected references

Acti 9 iEM3000 Series

Feature selection

Current Input/ Wh Accuracy	iEM3000 series Energy meters							
63 A Direct/ Class 1	iEM3100	iEM3115	iEM3110	iEM3135	iEM3150	iEM3155	iEM3165	iEM3175
1 A or 5 A CT/ Class 0.5S ⁽⁺¹⁾	iEM3200	iEM3215	iEM3210	iEM3235	iEM3250	iEM3255	iEM3265	iEM3275
125 A Direct/ Class 1	iEM3300		iEM3310	iEM3335	iEM3350	iEM3355	iEM3365	iEM3375
1/3rd or 1 V LVCT/ Class 0.5S						iEM3455	iEM3465	
Rogowski coil/ Class 0.5S						iEM3555	iEM3565	
Communication Protocol								
Modbus					■	■		
M-Bus				■				
BACnet							■	
LonWorks								■
Measurement (Intergrated)								
Active energy - Total and Partial energy	■	■	■	■	■	■	■	■
4 Quadrant Active, Reactive energy and Apparent energy				■		■	■	■
MID compliant (Wh) ⁽⁺²⁾ MID compliant (VARh) ⁽⁺²⁾		■	■	■		■	■	■
Demand (per-ph & average current, total power for P Q S) ⁽⁺³⁾						■	■	
Peak Demand (per-ph & average current, total power for P Q S) ⁽⁺³⁾						■	■	
Measurement (Instantaneous)								
Voltage				■	■	■	■	■
Current				■	■	■	■	■
Power - P Q S				■	■	■	■	■
Power factor				■	■	■	■	■
Frequency				■	■	■	■	■
Multi-Tariff, control by								
Internal clock		4		4		4	4	4
Digital Inputs		4		2		2	2	2
Communication		-		4		4	4	4
Digital inputs								
For Status, Tariff control or Input monitoring				1		1	1	1
Tariff control only		2						
Digital outputs								
Energy pulsing or Overload alarm				1		1	1	
Pulse output only			1					
Internal clock								
Quartz crystal based		■		■		■	■	■
Date/time format (DD-MMM-YYYY/hh:mm)		■		■		■	■	■
Commercial reference								
Commercial References/ordering references	A9MEM3100 A9MEM3200 A9MEM3300	A9MEM3115 A9MEM3215	A9MEM3110 A9MEM3210 A9MEM3310	A9MEM3135 A9MEM3235 A9MEM3335	A9MEM3150 A9MEM3250 A9MEM3350	A9MEM3155 A9MEM3255 A9MEM3355 A9MEM3455 A9MEM3555	A9MEM3165 A9MEM3265 A9MEM3365 A9MEM3465 A9MEM3565	A9MEM3175 A9MEM3275 A9MEM3375

⁽⁺¹⁾ MID certification available for x/5 A and x/1 A.

⁽⁺²⁾ MID certification not applicable for iEM34xx and iEM35xx series.

⁽⁺³⁾ Demand parameters available in iEM34xx and iEM35xx series only.

See your Schneider Electric representative for complete ordering information.

Acti 9 iEM3000 Series

Technical Specifications

		iEM31xx	iEM32xx	iEM33xx	iEM34xx	iEM35xx
Width in mm x number of modules		18 mm x 5	18 mm x 5	18 mm x 7	18 mm x 5	18 mm x 5
Wiring type (scheme)		3PH3W, 3PH4W, 1PH2W L-N, 1PH2W L-L, 1PH3W L-L-N				
Operating Temperature		-25°C to 70°C (-13 °F to 158 °F)				
Storage temperature		-40 °C to 85 °C (-40 °F to 185 °F)				
Wiring capacity		16 mm²	6 mm² for I and 4 mm² for V	50 mm²	6 mm² for I and 4 mm² for V	
LCD display		99999999.9 kWh	99999999.9 kWh / MWh	99999999.9 kWh	99999999.9 kWh / MWh	
IP Protection		IP40 front, IP20 casing				
Over voltage and measurement		Category III, Pollution Degree 2				
Operating Voltage		3 x 100/173 V AC to 3 x 277/480 V AC (50/60 Hz)				
Operating Current		0.5 A to 63 A	<i>Inom</i> 5 A: 50 mA to 6 A <i>Inom</i> 1 A: 10 mA to 1.2 A	1 A to 125 A	0.022 V to 0.4 V (0.333 V <i>Inom</i>) or 0.05 V to 1.2 V (1 V <i>Inom</i>) LVCTs	50 to 5000 A Rogowski Coil
Altitude		< 3000 m (9842 ft)				
Humidity		5% – 95%				
Voltage inputs	Measured voltage	Wye: 100 - 277 V L-N, 173 - 480 V L-L ±20% Delta: 173 - 480 V L-L ±20%				
	Overload	332 V L-N or 575 V L-L				
	Impedance	3 MΩ	3 MΩ	6 MΩ	3 MΩ	
	Frequency	50 / 60 Hz ±10%				
	Measurement category	III				
	Minimum wire temperature rating required	90 °C (194 °F)	90 °C (194 °F)	105 °C (221 °F)	90 °C (194 °F)	
	Maximum device consumption	-	< 10 VA	-	< 10 VA	
	Wire	16 mm² / 6 AWG	2.5 mm² / 14 AWG	50 mm² / 1 AWG	2.5 mm² / 14 AWG	
	Wire strip length	11 mm / 0.43 in	8 mm / 0.31 in	13 mm / 0.5 in	8 mm / 0.31 in	
	Torque	1.8 Nm / 15.9 in•lb	0.5 Nm / 4.4 in•lb	3.5 Nm / 30.9 in•lb	0.5 Nm / 4.4 in•lb	
Current inputs	Nominal current	-	1 A or 5 A	-	-	-
	Measured current	0.5 A to 63 A	20 mA to 6 A	1 A to 125 A	-	-
	Withstand	10 A continuous, 20 A at 10 sec/hr				
	Minimum wire temperature rating required	-	90 °C (194 °F)	-	90 °C (194 °F)	
	Impedance	< 0.3 mΩ	< 1 mΩ	< 0.2 mΩ	-	-
	Frequency	50 / 60 Hz ±10%				
	Burden	< 10 VA at 63 A	< 0.036 VA at 6 A	< 10 VA at 125 A		
	Wire	16 mm² / 6 AWG	6 mm² / 10 AWG	50 mm² / 1 AWG	6 mm² / 10 AWG	
	Wire strip length	11 mm / 0.43 in	8 mm / 0.31 in	13 mm / 0.5 in	8 mm / 0.31 in	
	Torque	1.8 Nm / 15.9 in•lb	0.8 Nm / 7.0 in•lb	3.5 Nm / 30.9 in•lb	0.8 Nm / 7.0 in•lb	
	Split-core LVCTs	-	-	-	0.333 V or 1 V nominal	
	Rogowski Coil	-	-	-	U018 Series of Rogowski Coils (up to 5000 A)	
	Minimum wire temperature rating required	-	-	-	90 °C (194 °F)	

Acti 9 iEM3000 Series



A9MEM3455



LVCT00102S



A9MEM3565



METSECTR25500

Recommended* Schneider make Split-core LVCT for iEM3455 and iEM3465

Part Number	Sensing Current	Frequency	Output
LVCT00102S	100A	50/60Hz	0 to 1/3V
LVCT00202S	200A	50/60Hz	0 to 1/3V
LVCT00302S	300A	50/60Hz	0 to 1/3V
LVCT00403S	400A	50/60Hz	0 to 1/3V
LVCT00603S	600A	50/60Hz	0 to 1/3V
LVCT00803S	800A	50/60Hz	0 to 1/3V
LVCT00804S	800A	50/60Hz	0 to 1/3V
LVCT01004S	1000A	50/60Hz	0 to 1/3V
LVCT01204S	1200A	50/60Hz	0 to 1/3V
LVCT01604S	1600A	50/60Hz	0 to 1/3V
LVCT02004S	2000A	50/60Hz	0 to 1/3V
LVCT02404S	2400A	50/60Hz	0 to 1/3V
LVCT00050S	50A	50/60Hz	0 to 1/3V
LVCT00101S	100A	50/60Hz	0 to 1/3V
LVCT00201S	200A	50/60Hz	0 to 1/3V

* Split core LVCT with 1 V output can also be used.

Rogowski Coil for iEM3555 and iEM3565

Part Number	Sensing Current	Frequency	Lead length (m)	Approximate Inside Diameter (mm)
METSECTR25500	5000A	50/60Hz	2.35	80
METSECTR30500	5000A	50/60Hz	2.35	96
METSECTR46500	5000A	50/60Hz	2.35	146
METSECTR60500	5000A	50/60Hz	2.35	191
METSECTR90500	5000A	50/60Hz	2.35	287

Measurement accuracy

		As per EN / IEC 62053-21/22/23	As per BS / EN / IEC 61557-12	As per EN 50470-3	Current range of operation
iEM31xx	Active energy	Class 1 (IEC 62053-21)	Class 1 (PMD DD)	Class B	$I_{max}=63$ A, $I_{ref}=10$ A, $I_{min}=0.5$ A, and $I_{st}=0.04$ A
	Reactive energy	Class 2 (IEC 62053-23)	Class 2 (PMD DD)	-	$I_{max}=63$ A, $I_b=10$ A, and $I_{st}=0.05$ A
iEM33xx	Active energy	Class 1 (IEC 62053-21)	Class 1 (PMD DD)	Class B	$I_{max}=125$ A, $I_{ref}=20$ A, $I_{min}=1$ A, and $I_{st}=0.08$ A
	Reactive energy	Class 2 (IEC 62053-23)	Class 2 (PMD DD)	-	$I_{max}=125$ A, $I_b=20$ A, and $I_{st}=0.1$ A
iEM32xx (x/1 A Current input)	Active energy	Class 1 (IEC 62053-21)	Class 1 (PMD SD, PMD Sx)	Class B	$I_{max}=1.2$ A, $I_{nom}=1$ A, and $I_{st}=0.002$ A
	Reactive energy	Class 2 (IEC 62053-23)	Class 2 (PMD Sx)	-	$I_{max}=1.2$ A, $I_{nom}=1$ A, and $I_{st}=0.003$ A
iEM32xx (x/5 A Current input)	Active energy	Class 0.5S (IEC 62053-22)	Class 1 (PMD SD, PMD Sx)	Class C	$I_{max}=6$ A, $I_{nom}=5$ A, and $I_{st}=0.005$ A
	Reactive energy	Class 2 (IEC 62053-23)	Class 2 (PMD Sx)	-	$I_{max}=6$ A, $I_{nom}=5$ A, and $I_{st}=0.015$ A
iEM34xx (LVCT, 0.333/1.0 V at I_{nom}) Field selectable	Active energy	$\pm 1\%$	-	-	Low voltage output for 0.333 V LVCT, $I_{max}=0.399$ V, $I_{nom}=0.333$ V, and $I_{min}=0.022$ V
	Reactive energy	$\pm 2\%$	-	-	
iEM35xx (from 50 A to 5000 A)	Active energy	$\pm 1\%$	-	-	$I_{max}=5000$ A, $I_{min}=50$ A
	Reactive energy	$\pm 2\%$	-	-	

Acti 9 iEM3000 Series dimensions

iEM3000/iEM3200 series dimensions

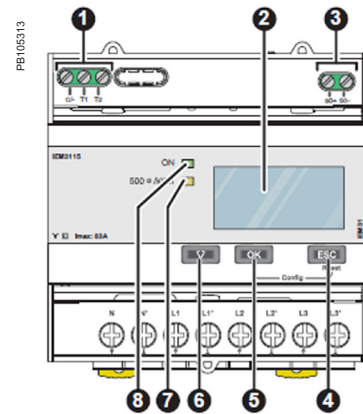
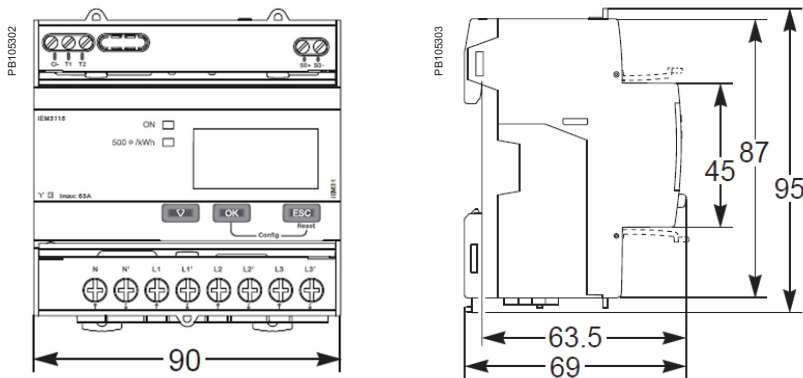

Acti 9 iEM3100/iEM3200 Series front flaps open and closed

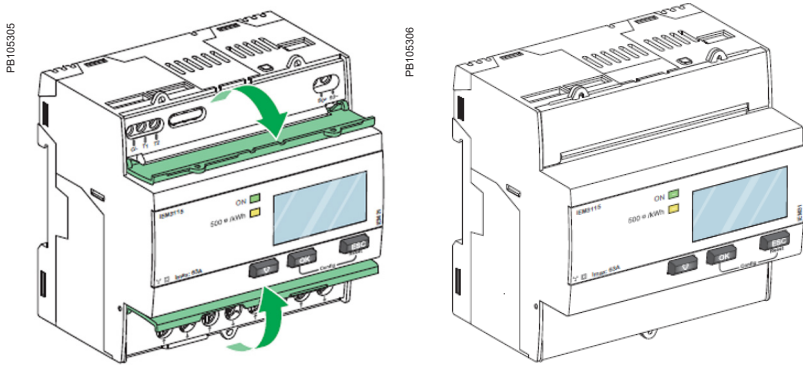

Acti 9 iEM3000 Series parts

1. Digital inputs for tariff control (iEM3115 / iEM3215)
2. Display for measurement and configuration
3. Pulse out for remote transfer (iEM3110 / iEM3210)
4. ESC Cancellation
5. OK Confirmation
6. Selection
7. Flashing yellow meter indicator to check accuracy
8. Green indicator: on/off, error

iEM3300 series dimensions

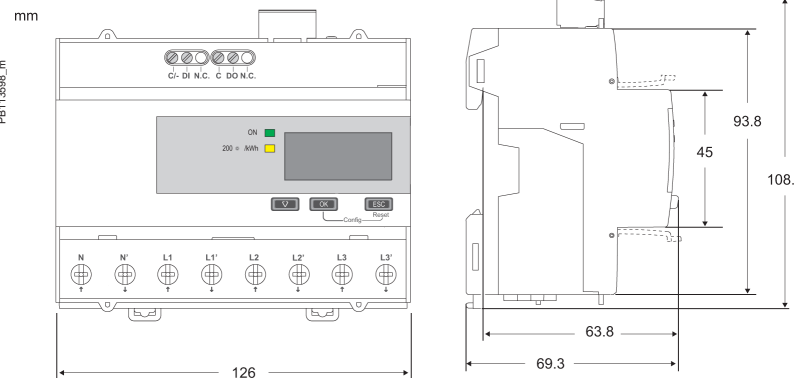
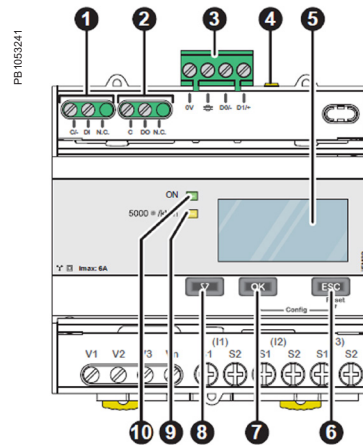
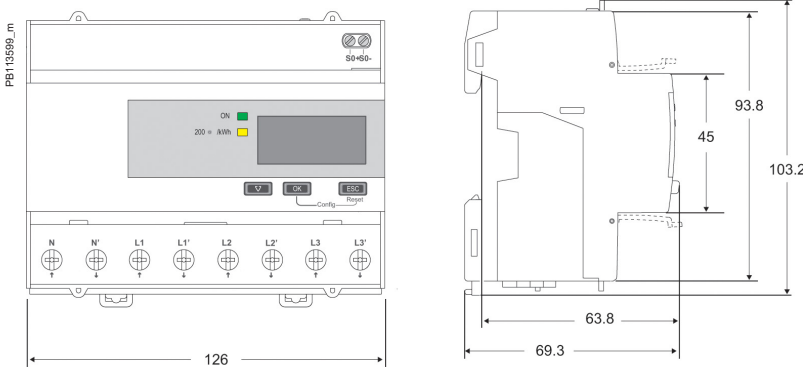

Acti 9 iEM3000 Series parts

1. Digital inputs for tariff control (iEM3115 / iEM3215)
2. Display for measurement and configuration
3. Pulse out for remote transfer (iEM3110 / iEM3210)
4. ESC Cancellation
5. OK Confirmation
6. Selection
7. Flashing yellow meter indicator to check accuracy
8. Green indicator: on/off, error

Please see the appropriate *Installation Guide* for accurate and complete information on the installation of this product.



www.se.com

Schneider Electric Industries SAS
35, Rue Joseph Monier
CS 30323
92506 Rueil Malmaison Cedex

RCS Nanterre 954 503 439
Capital social 928 298 512 €
www.se.com

June 2022
Acti 9 PowerLogic™ iEM3000
PLSED310049EN

© 2022 - Schneider Electric. All rights reserved.
All trademarks are owned by Schneider Electric
Industries SAS or its affiliated companies.

As standards, specifications and designs develop from time to time, please
ask for confirmation of the information given in this document.

Over 75 % of Schneider Electric products
have been awarded the Green Premium ecolabel.

