

Electrical network protection

Sepam series 40

User's manual
06/2025



Safety instructions

Safety symbols and messages

Read these instructions carefully and look at the equipment to become familiar with the device before trying to install, operate, service or maintain it. The following special messages may appear throughout this bulletin or on the equipment to warn of potential hazards or to call attention to information that clarifies or simplifies a procedure.



ANSI symbol.

IEC symbol.

Risk of electric shock

The addition of either symbol to a Danger or Warning safety label indicates that an electrical hazard exists, which will result in personal injury if the instructions are not followed.

Safety alert

This is the safety alert symbol. It is used to alert you to potential personal injury hazards. Obey all safety messages that follow this symbol to avoid possible injury or death.



Safety messages

DANGER

DANGER indicates an imminently hazardous situation which, if not avoided, **will result in death or serious injury**.

WARNING

WARNING indicates a potentially hazardous situation which, if not avoided, **can result in death or serious injury**.

CAUTION

CAUTION indicates a potentially hazardous situation which, if not avoided, **can result in minor or moderate injury**.

NOTICE

NOTICE is used to address practices not related to physical injury.

Important notes

Restricted liability

Electrical equipment should be serviced and maintained only by qualified personnel. No responsibility is assumed by Schneider Electric for any consequences arising out of the use of this manual. This document is not intended as an instruction manual for untrained persons.

Device operation

The user is responsible for checking that the rated characteristics of the device are suitable for its application. The user is responsible for reading and following the device's operating and installation instructions before attempting to commission or maintain it. Failure to follow these instructions can affect device operation and constitute a hazard for people and property.

Protective grounding

The user is responsible for compliance with all the existing international and national electrical codes concerning protective grounding of any device.

Introduction

1

Metering functions

2

Protection functions

3

Control and monitoring functions

4

Modbus communication

5

Installation

6

Use

7

Introduction	7
Selection guide by application	8
Protection functions suitable for low voltage	10
Presentation	12
Selection table	14
Technical characteristics	16
Environmental characteristics	17
Metering functions	19
General settings	20
Characteristics	21
Phase current	
Residual current	22
Average current and peak demand currents	23
Phase-to-phase voltage	
Phase-to-neutral voltage	24
Residual voltage	
Positive sequence voltage	25
Negative sequence voltage	
Frequency	26
Active, reactive and apparent power	27
Peak demand active and reactive power	
Power factor ($\cos \varphi$)	28
Active and reactive energy	29
Temperature	30
Network diagnosis functions	31
Tripping context	
Tripping current	31
Negative sequence / unbalance	32
Phase displacement φ_0	
Phase displacement $\varphi_1, \varphi_2, \varphi_3$	33
Disturbance recording	34
Fault locator	35
Machine operation assistance functions	37
Thermal capacity used	
Cooling time constant	37
Operating time before tripping	
Waiting time after tripping	38
Running hours counter and operating time	
Starting current and starting/overload time	39
Number of starts before inhibition	
Start inhibit time delay	40

Switchgear diagnosis functions	41
Cumulative breaking current and number of operations	41
Operating time	
Charging time	42
VT supervision	43
CT supervision	45
Protection functions	46
Setting ranges	48
Undervoltage	51
Positive sequence undervoltage and phase rotation direction check	52
Remanent undervoltage	53
Directional active overpower	54
Directional reactive overpower	55
Phase undercurrent	56
Temperature monitoring	57
Negative sequence / unbalance	58
Broken conductor	60
Negative sequence overvoltage	61
Excessive starting time, locked rotor	62
Thermal overload	63
Phase overcurrent	72
Phase overcurrent Cold Load Pick-Up/Blocking	74
Breaker failure	76
Earth fault	78
Earth fault Cold Load Pick-Up/Blocking	80
Voltage-restrained phase overcurrent	82
Overvoltage	84
Neutral voltage displacement	85
Starts per hour	86
Directional phase overcurrent	87
Directional earth fault	91
Recloser	99
Overfrequency	102
Underfrequency	103
General	104

Control and monitoring functions	111
Description	112
Definition of symbols	113
Logic input / output assignment	114
Circuit breaker / contactor control ANSI code 94/69	116
Logic discrimination ANSI code 68	120
Disturbance recording triggering	125
Switching of groups of settings	126
Local indication ANSI code 30	127
Control matrix	129
Logic equations	130
Self-tests and fail-safe position	135
Modbus communication	141
Presentation	142
Modbus protocol	143
Configuring the communication interfaces	146
Commissioning and diagnosis	152
Data addresses and encoding	160
Time-tagging of events	173
Access to remote settings	178
Access to remote settings	182
Disturbance recording	195
Reading Sepam identification	197
Installation	199
Safety and Cyber-security instructions	200
Precautions	201
Equipment identification	202
Base unit	206
1 A/5 A current transformers	218
Voltage transformers	220
LPCT type current sensors	221
CSH120, CSH200 and CSH300 Core balance CTs	224
CSH30 interposing ring CT	226
ACE990 Core balance CT interface	228
MES114 modules	230
Optional remote modules	233
MET148-2 Temperature sensor module	234
MSA141 Analog output module	236
DSM303 Remote advanced UMI module	238
Communication accessory selection guide	240

Connection of communication interfaces	241
ACE949-2 2-wire RS 485 network interface	243
ACE959 4-wire RS 485 network interface	244
ACE937 fiber optic interface	245
ACE969TP-2 and ACE969FO-2 Multi-protocol interfaces	246
ACE850TP and ACE850FO Multi-protocol interfaces	252
ACE909-2 RS 232/RS 485 converter	258
ACE919CA and ACE919CC RS 485/RS 485 converters	260
ECI850 IEC 61850 Sepam server	262
Use	267
User Machine Interfaces	268
SFT2841 setting and operating software	269
SFT2841 setting and operating software	270
UMI on front panel	278
Advanced UMI	279
Default parameters, all applications	285
Commissioning	286
Principles and methods	286
Testing and metering equipment required	287
General examination and preliminary actions	288
Checking of parameter and protection settings	289
Checking of phase current and voltage input connection	290
Checking of residual voltage input connection	296
Checking of residual current and residual voltage input connection	297
Checking of logic input and output connection	298
Validation of the complete protection chain	
Checking of optional modules connection	299
Test sheet	300
Maintenance	302
Firmware modifications	304



Selection guide by application	8
Protection functions suitable for low voltage	10
Presentation	12
Selection table	14
Technical characteristics	16
Environmental characteristics	17

The selection guide by application suggests Sepam type(s) suitable for your protection requirements, based on your application characteristics. The most typical applications are presented along with the associated Sepam type. Each application example is described:

- By a single-line diagram specifying
 - the device to be protected
 - the network configuration
 - the position of the metering sensors
- By the standard and specific Sepam functions to be implemented to protect the application concerned.

		Series 20		Series 40					
Protections									
Current		■	■	■	■	■	■	■	
Voltage				■	■	■		■	
Frequency				■	■	■		■	
Specific			Breaker failure		Disconnection (ROCOF)		Directional earth fault	Directional earth fault and phase	Directional earth fault
Applications									
Substation		S20 S24		S40 S41 S42 S43 S44 S50(4) S51(4) S52(4) S53(4) S54					
Busbar				B21 B22					
Transformer		T20 T24		T40 T42 T50(5) T52(5)					
Motor		M20		M40 M41					
Generator				G40					
Capacitor									
Characteristics									
Logic inputs/ outputs	Inputs	0 to 10		0 to 10		0 to 10			
	Outputs	4 to 8		4 to 8		4 to 8			
Temperature sensors		0 to 8		0 to 8		0 to 16			
Channel	Current	3I + I0		-		3I + I0			
	Voltage	-		3V + V0		3V			
	LPCT (1)	Yes		-		Yes			
Communication ports		1 to 2		1 to 2		1 to 2			
Control	Matrix (2)	Yes		Yes		Yes			
	Logic equation editor	-		-		Yes			
	Logipam (3)	-		-		-			
Other	Memory cartridge with settings	-		-		-			
	Backup battery	-		-		-			

(1) LPCT: Low-Power Current Transducer conforming to standard IEC 60044-8.

(2) Control matrix used for simple assignment of data from the protection, control and monitoring functions.

(3) Logipam: Ladder language PC programming environment for extended use of Sepam series 80 functions.



(4) S5X applications are identical to S4X applications with the following additional functions:

- earth fault and phase overcurrent cold load pick-up
- broken conductor detection
- fault locator

(5) T5X applications are identical to T4X applications with the following additional functions:

- earth fault and phase overcurrent cold load pick-up
- broken conductor detection

The list of protection functions is given for information only.
Direct earthing or impedance earthing have been represented by the same pictogram, i.e. by a direct earthing system.

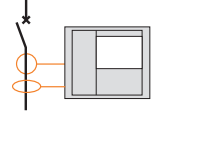
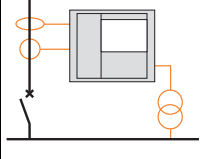
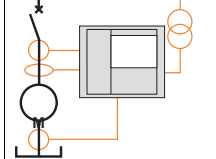
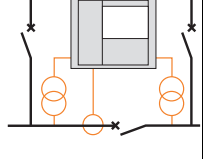
Series 60		Series 80						
								
								
■	■	■	■	■	■	■		
■	■	■	■	■	■	■		
■	■	■	■	■	■	■		
	Directional earth fault	Directional earth fault	Directional earth fault and phase	Disconnection (ROCOF)	Transformer or machine-transformer unit differential	Machine differential	Busbar voltage and frequency protection	Capacitor bank unbalance
	(S60)	(S62)	(S80) (S81) (S82) (S84)					
			(B80)				(B83)	
	(T60) (T62)	(T81) (T82)		(T87)				
	(M61)	(M81)		(M88) (M87)				
	(G60) (G62)	(G82)		(G88) (G87)				
	(C60)							(C86)
0 to 28		0 to 42		0 to 42		0 to 42		0 to 42
4 to 16		5 to 23		5 to 23		5 to 23		5 to 23
0 to 16		0 to 16		0 to 16		0 to 16		0 to 16
3I + I0		3I + 2 x I0		2 x 3I + 2 x I0		3I + I0		2 x 3I + 2 x I0
3V, 2U + V0 or Vnt		3V + V0		3V + V0		2 x 3V + 2 x V0		3V + V0
Yes		Yes		Yes		Yes		Yes
1 to 2		2 to 4		2 to 4		2 to 4		2 to 4
Yes		Yes		Yes		Yes		Yes
Yes		Yes		Yes		Yes		Yes
-		Yes		Yes		Yes		Yes
Yes		Yes		Yes		Yes		Yes
Yes		Yes		Yes		Yes		Yes

All the information relating to the Sepam range can be found in the following documents:

- Sepam catalog, reference SEPED303005EN
- Sepam series 20 user's manual, reference PCRED301005EN
- Sepam series 40 user's manual, reference PCRED301006EN
- Easergy Sepam series 60 user's manual, reference SEPED310017EN
- Easergy Sepam series 80 functions user's manual, reference SEPED303001EN
- Easergy Sepam series 80 Modbus communication user's manual, reference SEPED303002EN

- Easergy Sepam series 80 operation manual, reference SEPED303003EN
- Sepam DNP3 communication user's manual, reference SEPED305001EN
- Sepam IEC 60870-5-103 communication user's manual, reference SEPED305002EN
- Sepam IEC 61850 communication user's manual, reference SEPED306024EN

Low voltage earthing systems

There are 4 low voltage (LV) earthing systems designated by a 2 or 3-letter acronym:

- TN-S
- TN-C
- TT
- IT

The letters making up the acronym have the following meanings:

Letter	Meaning
First letter	Transformer neutral point
I	Earthed with an impedance
T	Directly earthed
Second letter	Electrical exposed conductive parts of the consumer
T	Earthed
N	Connected to the neutral conductor
Third letter (optional)	Protective Earth conductor
S	Separate N neutral conductor and PE Protective Earth conductor
C	Combined N neutral conductor and PE Protective Earth conductor (PEN)

Compatibility of Sepam low voltage protection functions

Sepam protection functions can be used with low voltage (LV) as long as the conditions below are met:

- The distribution circuit must be rated higher than 32 A.
- The installation must comply with standard IEC 60364.

For additional information about the compatibility of Sepam protection functions with low voltage, please contact Schneider Electric technical support.

The table below lists the Sepam protection functions suitable for low voltage according to the earthing system used. Sepam protection functions not listed in this table are not suitable for low voltage. The protection functions listed in this table are available according to the Sepam type.

Protection	ANSI code	Earthing system				Comments
		TN-S	TN-C	TT	IT	
Phase overcurrent	50/51	■	■	■	■	Neutral conductor not protected
Earth fault/Sensitive earth fault	50N/51N	■	■	■	■ (1)	
Earth fault/Sensitive earth fault	50G/51G	■	■	■	■ (3)	
Negative sequence/unbalance	46	■	■	■	■	Threshold to be adapted to the phase unbalance
Thermal overload for cables/capacitor/transformer/motor/generic	49RMS	■	■	■	■	Neutral conductor not protected
Restricted earth fault	64REF	■	■	■	■ (3)	
Two-winding transformer differential	87T	■	■	■	■	
Directional phase overcurrent	67	■	■	■ (4)	■ (4)	
Directional earth fault	67N/67NC					Incompatible with LV diagrams (4-wire)
Directional active overpower	32P	■	■	(2)	(2)	
Directional reactive overpower	32Q	■	■	(2)	(2)	
Undervoltage (L-L or L-N)	27	■	■	■	■	
Remanent undervoltage	27R	■	■	■	■	
Overvoltage (L-L or L-N)	59	■	■	■	■	
Neutral voltage displacement	59N	■	■	(4)	(4)	Residual voltage not available with 2 VTs
Negative sequence overvoltage	47	■	■	■	■	
Overfrequency	81H	■	■	■	■	
Underfrequency	81L	■	■	■	■	
Rate of change of frequency	81R	■	■	■	■	
Synchro-check	25	■	■	■	■	

■ : Protection function suitable for low voltage (according to Sepam)

- (1) Not recommended even on the second fault.
 (2) 2-wattmeter method not suitable for unbalanced loads.
 (3) Residual current too low in IT.
 (4) 2 phase-to-phase VTs.



Sepam series 40, a modular solution.

The Sepam series 40 family of protection and metering units is designed for the operation of machines and utility substations and electrical distribution networks in industrial installations for all voltage levels. It consists of simple, high-performance solutions, suited to demanding applications that call for current and voltage metering.

Sepam series 40 selection guide by application

Selection criteria								
Basic protection functions	I	I, U and f	I, U and f	I, U and f	I, U and f	I, U and f	I, U and f	I, U and f
Specific protection functions	Directional earth fault			Directional earth fault		Directional earth fault and phase overcurrent		
Applications								
Substation	S43	S53 ⁽¹⁾	S40	S50 ⁽¹⁾	S41	S51 ⁽¹⁾	S42	S52 ⁽¹⁾
			S44	S54				
Transformer			T40	T50 ⁽²⁾			T42	T52 ⁽²⁾
Motor			M40		M41			
Generator			G40					

⁽¹⁾ S5X applications are identical to S4X applications with the following additional functions:

- earth fault and phase overcurrent cold load pick-up
- broken conductor detection
- fault locator

⁽²⁾ T5X applications are identical to T4X applications with the following additional functions:

- earth fault and phase overcurrent cold load pick-up
- broken conductor detection

Main functions

Protection

- phase protection and earth fault protection with adjustable reset time, with switching of the active group of settings and logic discrimination
- earth fault protection insensitive to transformer switching
- RMS thermal overload protection that takes into account external operating temperature and ventilation operating rates
- directional earth fault protection suitable for all isolated, compensated or impedant neutral systems
- directional phase overcurrent protection with voltage memory
- voltage and frequency protection functions (under/over, etc.).

Communication

Sepam can be connected to a supervision communication network (S-LAN) based on the following communication protocols: Modbus RTU, DNP3, IEC 60870-5-103, IEC 61850.

All the data needed for centralized equipment management from a remote control and monitoring system are available via the communication port:

- in read mode: all measurements, alarms, settings, etc.
- in write mode: breaking device remote control orders, etc.

Diagnosis

3 types of diagnosis data for improved operation:

- network and machine diagnosis: tripping current, context of the last 5 trips, unbalance ratio, disturbance recording
- switchgear diagnosis: cumulative breaking current, trip circuit supervision, operating time
- diagnosis of the protection unit and additional modules: continuous self-testing, watchdog.

Control and monitoring

- circuit breaker program logic ready to use, requiring no auxiliary relays or additional wiring
- adaptation of control functions by a logic equation editor
- preprogrammed, customizable alarm messages on UMI.



Sepam series 40 with basic UMI and with fixed advanced UMI.

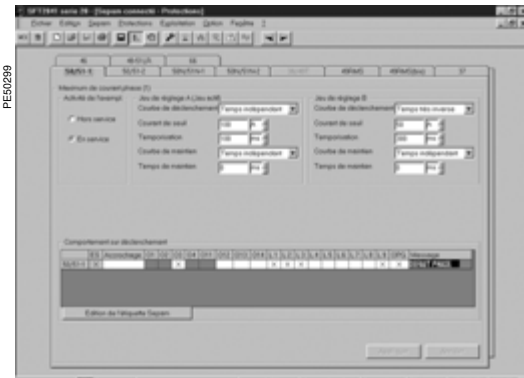

Example of an SFT2841 software screen.

User Machine Interface

2 levels of User Machine Interface (UMI) are available according to the user's needs:

■ **basic UMI:**

an economical solution for installations that do not require local operation (run via a remote monitoring and control system)

■ **fixed or remote advanced UMI:**

a graphic LCD display and 9-key keypad are used to display the measurement and diagnosis values, alarm and operating messages and provide access to protection and parameter setting values, for installations that are operated locally..

Setting and operating software

The **SFT2841** PC software tool gives access to all the Sepam functions, with all the facilities and convenience provided by a Windows type environment.

Protection	ANSI code	Substation					Transformer		Motor	Generator
		S40 S50	S41 S51	S42 S52	S43 S53	S44 S54	T40 T50	T42 T52	M40 M41	G40
Phase overcurrent	50/51	4	4	4	4	4	4	4	4	4
Phase overcurrent cold load pick-up/blocking	CLPU 50/51	4 ⁽⁴⁾	4 ⁽⁴⁾	4 ⁽⁴⁾	4 ⁽⁴⁾	4 ⁽⁴⁾	4 ⁽⁴⁾	4 ⁽⁴⁾		
Voltage-restrained phase overcurrent	50V/51V									1
Earth fault, sensitive earth fault	50N/51N 50G/51G	4	4	4	4	4	4	4	4	4
Earth fault cold load pick-up/blocking	CLPU 50N/51N	4 ⁽⁴⁾	4 ⁽⁴⁾	4 ⁽⁴⁾	4 ⁽⁴⁾	4 ⁽⁴⁾	4 ⁽⁴⁾	4 ⁽⁴⁾		
Breaker failure	50BF	1	1	1	1	1	1	1	1	1
Negative sequence/unbalance	46	2	2	2	2	2	2	2	2	2
Broken conductor	46 BC	1 ⁽⁴⁾	1 ⁽⁴⁾	1 ⁽⁴⁾	1 ⁽⁴⁾	1 ⁽⁴⁾	1 ⁽⁴⁾	1 ⁽⁴⁾		
Directional phase overcurrent	67			2				2		
Directional earth fault	67N/67NC		2	2	2			2		
Directional active overpower	32P		1	1	1				1	1
Directional reactive overpower	32Q/40								1	1
Thermal overload	49RMS						2	2	2	2
Phase undercurrent	37								1	1
Excessive starting time, locked rotor	48/51LR/14								1	1
Starts per hour	66								1	1
Positive sequence undervoltage	27D								2	2
Remanent undervoltage	27R								1	1
Undervoltage ⁽³⁾	27/27S	2	2	2		2	2	2	1	2
Overvoltage ⁽³⁾	59	2	2	2		2	2	2	2	2
Neutral voltage displacement	59N	2	2	2			2	2		2
Negative sequence overvoltage	47	1	1	1		1	1		1	1
Overfrequency	81H	2	2	2			2	2		2
Underfrequency	81L	4	4	4			4	4		4
Recloser (4 cycles)	79	□	□	□	□	□				
Temperature monitoring (8 or 16 RTDs, 2 set points per RTD)	38/49T						□	□	□	□
Thermostat/Buchholz	26/63						□	□		
Control and monitoring										
Circuit breaker/contactors control ⁽¹⁾	94/69	■	■	■	■	■	■	■	■	■
Latching/acknowledgment	86	■	■	■	■	■	■	■	■	■
Logic discrimination	68	□	□	□	□	□	□	□	□	□
Switching of groups of settings		■	■	■	■	■	■	■	■	■
Annunciation	30	■	■	■	■	■	■	■	■	■
Logic equation editor		■	■	■	■	■	■	■	■	■

■ Standard, □ according to parameter setting and MES114/MES114E/MES114F or MET148-2 input/output module options

(1) For shunt trip unit or undervoltage trip unit.

(2) 2 modules possible.

(3) Exclusive choice, phase-to-neutral voltage or phase-to-phase voltage for each of the 2 relays.

(4) Only for S50, S51, S52, S53, S54 T50, T52 applications.

(5) Only for S50, S51, S52, S53, S54 applications.

Metering	ANSI code	Substation					Transform		Motor		Generator
		S40 S50	S41 S51	S42 S52	S43 S53	S44 S54	T40 T50	T42 T52	M40 M41	G40	
Phase current I1, I2, I3 RMS, residual current I0		■	■	■	■	■	■	■	■	■	■
Demand current I1, I2, I3, peak demand current IM1, IM2, IM3		■	■	■	■	■	■	■	■	■	■
Voltage U21, U32, U13, V1, V2, V3, residual voltage V0		■	■	■	■	■	■	■	■	■	■
Positive sequence voltage Vd/rotation direction, negative sequence voltage Vi		■	■	■	■	■	■	■	■	■	■
Frequency		■	■	■	■	■	■	■	■	■	■
Active, reactive and apparent power P, Q, S		■	■	■	■	■	■	■	■	■	■
Peak demand power PM, QM, power factor		■	■	■	■	■	■	■	■	■	■
Calculated active and reactive energy (±W.h, ±var.h)		■	■	■	■	■	■	■	■	■	■
Active and reactive energy by pulse counting (±W.h, ±var.h)		□	□	□	□	□	□	□	□	□	□
Temperature							□	□	□	□	□
Network and machine diagnosis											
Tripping context		■	■	■	■	■	■	■	■	■	■
Tripping current Tripl1, Tripl2, Tripl3, Tripl0		■	■	■	■	■	■	■	■	■	■
Unbalance ratio/negative-sequence current li		■	■	■	■	■	■	■	■	■	■
Peak demand negative sequence and positive sequence current ratio ⁽⁴⁾		■	■	■	■	■	■	■	■	■	■
Phase displacement φ0, φ1, φ2, φ3		■	■	■	■	■	■	■	■	■	■
Disturbance recording		■	■	■	■	■	■	■	■	■	■
Fault locator ⁽⁵⁾	21FL	■	■	■	■	■					
Thermal capacity used							■	■	■	■	■
Remaining operating time before overload tripping							■	■	■	■	■
Waiting time after overload tripping							■	■	■	■	■
Running hours counter/operating time							■	■	■	■	■
Starting current and time									■	■	
Start inhibit time, number of starts before inhibition									■	■	
Switchgear diagnosis											
Cumulative breaking current		■	■	■	■	■	■	■	■	■	■
Trip circuit supervision		□	□	□	□	□	□	□	□	□	□
Number of operations, operating time, charging time		□	□	□	□	□	□	□	□	□	□
CT/VT supervision	60FL	■	■	■	■	■	■	■	■	■	■
Additional modules											
8 temperature sensor inputs - MET148-2 module ⁽²⁾							□	□	□	□	□
1 low level analog output - MSA141 module		□	□	□	□	□	□	□	□	□	□
Logic inputs/outputs - MES114/MES114E/MES114F module (10I/4O)		□	□	□	□	□	□	□	□	□	□
Communication interface - ACE949-2, ACE959, ACE937, ACE969TP-2 or ACE969FO-2, ACE850TP or ACE850FO		□	□	□	□	□	□	□	□	□	□

■ Standard, □ according to parameter setting and MES114/MES114E/MES114F or MET148-2 input/output module options

(1) For shunt trip unit or undervoltage trip unit.

(2) 2 modules possible.

(3) Exclusive choice, phase-to-neutral voltage or phase-to-phase voltage for each of the 2 relays.

(4) Only for S50, S51, S52, S53, S54 T50, T52 applications.

(5) Only for S50, S51, S52, S53, S54 applications.

1

Weight

Minimum weight (base unit with basic UMI and without MES114)	1.4 kg (3.09 lb)
Maximum weight (base unit with advanced UMI and MES114)	1.9 kg (4.19 lb)

Analog inputs

Current transformer 1 A or 5 A CT (with CCA630 or CA634) 1 A to 6250 A ratings	Input impedance	< 0.02 Ω
	Consumption	< 0.02 VA at 1 A < 0.5 VA at 5 A
	Rated thermal withstand	4 In
	1-second overload	100 In (500 A)
	Voltage transformer 220 V to 250 kV ratings	Input impedance
	Consumption	< 0.015 VA (VT 100 V)
	Input voltage	90 to 230/√3 V
	Rated thermal withstand	240 V
	1-second overload	480 V
	Isolation of outputs from other isolated groups	Enhanced

Temperature sensor input (MET148-2 module)

Type of sensor	Pt 100	Ni 100 / 120
Isolation from earth	None	None
Current injected in sensor	4 mA	4 mA
Maximum distance between sensor and module	1 km (0.62 mi)	

Logic inputs

	MES114	MES114E		MES114F	
Voltage	24 to 250 V DC	110 to 125 V DC	110 V AC	220 to 250 V DC	220 to 240 V AC
Range	19.2 to 275 V DC	88 to 150 V DC	88 to 132 V AC	176 to 275 V DC	176 to 264 V AC
Frequency	-	-	47 to 63 Hz	-	47 to 63 Hz
Typical consumption	3 mA	3 mA	3 mA	3 mA	3 mA
Typical switching threshold	14 V DC	82 V DC	58 V AC	154 V DC	120 V AC
Input limit voltage	At state 1	≥ 19 V DC	≥ 88 V DC	≥ 88 V AC	≥ 176 V DC
	At state 0	≤ 6 V DC	≤ 75 V DC	≤ 22 V AC	≤ 137 V DC
Isolation of inputs in relation to other isolated groups	Enhanced	Enhanced	Enhanced	Enhanced	Enhanced

Relay outputs

Control relay outputs (O1, O2, O3, O11 contacts) ⁽¹⁾

Voltage	DC	24/48 V DC	127 V DC	220 V DC	250 V DC	-
	AC (47.5 to 63 Hz)	-	-	-	-	100 to 240 V AC
Continuous current		8 A	8 A	8 A	8 A	8 A
Breaking capacity	Resistive load	8 A / 4 A	0.7 A	0.3 A	0.2 A	-
	L/R load < 20	6 A / 2 A	0.5 A	0.2 A	-	-
	L/R load < 40 ms	4 A / 1 A	0.2 A	0.1 A	-	-
	Resistive load	-	-	-	-	8 A
	p.f. load > 0.3	-	-	-	-	5 A
Making capacity		< 15 A for 200 ms				
Isolation of outputs from other isolated groups		Enhanced				

Annunciation relay output (O4, O12, O13, O14 contacts)

Voltage	DC	24/48 V DC	127 V DC	220 V DC	250 V DC	-
	AC (47.5 to 63 Hz)	-	-	-	-	100 to 240 V AC
Continuous current		2 A	2 A	2 A	2 A	2 A
Breaking capacity	Resistive load	2 A / 1 A	0.6 A	0.3 A	0.2 A	-
	L/R load < 20 ms	2 A / 1 A	0.5 A	0.15 A	-	-
	p.f. load > 0.3	-	-	-	-	1 A
Isolation of outputs from other isolated groups		Enhanced				

Power supply

Voltage	24/250 V DC	110/240 V AC
Range	-20% +10%	-20% +10% (47.5 to 63 Hz)
Deactivated consumption ⁽²⁾	< 6 W	< 6 VA
Maximum consumption ⁽²⁾	< 11 W	< 25 VA
Inrush current	< 10 A for 10 ms < 28 A for 100 μs	< 15 A for first half-period
Acceptable momentary outages	20 ms	20 ms

Analog output (MSA141 module)

Current	4 - 20 mA, 0 - 20 mA, 0 - 10 mA
Load impedance	< 600 Ω (wiring included)
Accuracy	0.50 % full scale or 0.01 mA

⁽¹⁾ Relay outputs (O1, O2, O3, O11 contact) comply with clause 6.7 of standard C37.90, (30 A, 200 ms, 2000 operations).

⁽²⁾ According to configuration.

Electromagnetic compatibility	Standard	Level / Class	Value
Emission tests			
Disturbing field emission	CISPR 22 EN 55022	A	
Conducted disturbance emission	CISPR 22 EN 55022	B	
Immunity tests — Radiated disturbances			
Immunity to radiated fields	IEC 61000-4-3 ANSI C37.90.2	III	10 V/m ; 80 MHz - 2 GHz (1) 20 V/m ; 80 MHz - 1 GHz
Electrostatic discharge	IEC 61000-4-2 ANSI C37.90.3		8 kV air ; 6 kV contact 8 kV air ; 4 kV contact
Immunity to magnetic fields at network frequency	IEC 61000-4-8	IV	30 A/m (continuous) - 300 A/m (13 s)
Immunity tests — Conducted disturbances			
Immunity to conducted RF disturbances	IEC 60000-4-6		10 V
Immunity to conducted disturbances in common mode from 0 Hz to 150 kHz	IEC 61000-4-16	III	
Fast transient bursts	IEC 61000-4-4	IV	4 kV ; 5 kHz and 100 kHz
1 MHz damped oscillating wave	ANSI C37.90.1		2.5 kV MC and MD
100 kHz damped oscillating wave	IEC 61000-4-12		2 kV MC
Slow damped oscillating wave (100 kHz to 1 Mhz)	IEC 61000-4-18	III	(2) (3)
Surges	IEC 61000-4-5		2 kV MC ; 1 kV MD
AC & DC voltage dips & interruptions	IEC 61000-4-29 IEC 61000-4-11		0% Un - 0.1s . Crit. A; 40% Un - 0.1s . Crit. A 70% Un - 0.5s . Crit. A; 0% - 5s - Crit. C
Mechanical robustness			
In operation			
Vibrations	IEC 60255-21-1 IEC 60068-2-6 IEC 60068-2-64	2 Fc 2M1	1 Gn ; 10 Hz - 150 Hz 3 Hz - 13.2 Hz ; a = ±1 mm (±0.039 in)
Shocks	IEC 60255-21-2	2	10 Gn / 11 ms
Earthquakes	IEC 60255-21-3	2	2 Gn (horizontal axes) 1 Gn (vertical axes)
De-energized			
Vibrations	IEC 60255-21-1	2	2 Gn ; 10 Hz - 150 Hz
Shocks	IEC 60255-21-2	2	30 Gn / 11 ms
Jolts	IEC 60255-21-2	2	20 Gn / 16 ms
(1) When protections functions 59 are used, Us (or Vs) must be higher than 0.55 Vnp or Unp. (2) When protections functions 50/51 or 67 are used, Is must be higher than 0.5 In. (3) When protections functions 50N/51N or 67N are used and I0 is calculated on the sum of the phase currents, Is0 must be higher than 0.15 In0.			
CSH30 horizontal with 2 clips; CSH120 / CSH200 horizontal with 3 plastic cable ties			
Mechanical robustness			
Operating (Energized)			
Vibrations	IEC 60255-21-1	2	0.075mm / 1g; 10 – 150Hz
Shocks	IEC 60255-21-2	2	10g / 11ms
Earthquakes	IEC 60255-21-3	2	7.5mm / 2g (H); 3.5mm / 1g (V); 3 – 35Hz
No Operating (De-energized)			
Vibrations	IEC 60255-21-1	2	2g; 10 – 150Hz
Shocks	IEC 60255-21-2	2	30g / 11ms
Jolts	IEC 60255-21-2	2	20g / 16ms
CSH30 vertical with 1 clip; CSH120 vertical with 2 clips; CSH300 horizontal with 3 plastic cable ties			
Mechanical robustness			
Operating (Energized)			
Vibrations	IEC 60255-21-1	1	0.035mm / 0.5g; 10 – 150 Hz
Shocks	IEC 60255-21-2	1	5g / 11ms
Earthquakes	IEC 60255-21-3	1	3.5mm / 1g (H); 1.5mm / 0.5g (V); 3 – 35Hz
No Operating (De-energized)			
Vibrations	IEC 60255-21-1	1	1g; 10 – 150Hz
Shocks	IEC 60255-21-2	1	15g / 11ms
Jolts	IEC 60255-21-2	1	10g / 16ms

Climatic withstand	Standard	Level/Class	Value
During operation			
Exposure to cold	IEC 60068-2-1	Ad	-25°C (-13°F)
Exposure to dry heat	IEC 60068-2-2	Bd	+70°C (+158°F)
Continuous exposure to damp heat	IEC 60068-2-78	Cab	10 days; 93% RH; 40°C (104°F)
Salt mist	IEC 60068-2-52	Kb/2	3 days
Influence of corrosion/2-gas test	IEC 60068-2-60	Method 1	21 days; 75% RH; 25°C (77°F); 0.1 ppm H ₂ S; 0.5 ppm SO ₂
Influence of corrosion/4-gas test	IEC 60068-2-60	Method 4	21 days; 70% RH; 25°C (77°F); 0.01 ppm H ₂ S; 0.2 ppm SO ₂ ; 0.2 ppm NO ₂ ; 0.01 ppm Cl ₂
	EIA 364-65A	IIIA	42 days; 75% RH; 30 °C (86 °F) ; 0.1 ppm H ₂ S ; 0.2 ppm SO ₂ ; 0.2 ppm NO ₂ ; 0.02 ppm Cl ₂
In storage ⁽¹⁾			
Temperature variation with specified variation rate	IEC 60068-2-14	Nb	-25°C to +70°C (-13°F to +158°F) 5°C/min
Exposure to cold	IEC 60068-2-1	Ab	-25°C (-13°F)
Exposure to dry heat	IEC 60068-2-2	Bb	+70°C (+158°F)
Continuous exposure to damp heat	IEC 60068-2-78	Cab	56 days; 93% RH; 40°C (104°F)
	IEC 60068-2-30	Db	6 days; 95% RH; 55°C (131°F)
Safety			
Enclosure safety tests			
Front panel tightness	IEC 60529	IP52	Other panels IP20
	NEMA	Type 12	
Resistance to mechanical stress	IEC 60255-27	IK07	2J
Fire withstand	IEC 60695-2-11		650°C (1200°F) with glow wire
Electrical safety tests			
1.2/50 μs impulse wave	IEC 60255-27		5 kV ⁽²⁾
Power frequency dielectric withstand	IEC 60255-27		2 kV 1min ⁽³⁾
	ANSI C37.90		1 kV 1 min (annunciation output) 1.5 kV 1 min (control output)
Certification			
CE	Norme harmonisée :		Directives européennes :
	<ul style="list-style-type: none"> ■ EN/IEC 60255-26 :2013 ■ EN 60255-27: 2014/IEC 60255-27:2013 ■ EN IEC 63000:2018 / IEC 63000:2016 		<ul style="list-style-type: none"> ■ EMC European Directive CEM 2014/30/EU ■ Low Voltage European Directive 2014/35/EU ■ RoHS directive 2011/65/EU amended by Directive (EU) 2015/863
UK CA	BS-designated standards :		UK regulations (Statutory Instruments):
	<ul style="list-style-type: none"> ■ BS EN 60255-26 :2013 ■ BS EN 60255-27: 2013 ■ BS EN IEC 63000:2018 		<ul style="list-style-type: none"> ■ SI 2016 No. 1101 ■ SI 2016 No. 1091 ■ SI 2012 No. 3032
UL 	UL508-CSA C22.2 no. 14-95		File E212533
CSA	CSA C22.2 no. 14-95/no. 0.17-00		File 210625

(1) Sepam must be stored in its original packaging.

(2) Except for communication: 3 kV in common mode and 1 kV in differential mode.

(3) Except for communication: 1 kVrms.

(4) See the appendix in "Installation and operation" manual SEPED303003EN, "Functional Safety" section

General settings	20
Characteristics	21
Phase current	
Residual current	22
Average current and peak demand currents	23
Phase-to-phase voltage	
Phase-to-neutral voltage	24
Residual voltage	
Positive sequence voltage	25
Negative sequence voltage	
Frequency	26
Active, reactive and apparent power	27
Peak demand active and reactive power	
Power factor ($\cos \varphi$)	28
Active and reactive energy	29
Temperature	30
Tripping context	
Tripping current	31
Negative sequence / unbalance	32
Phase displacement φ_0	
Phase displacement $\varphi_1, \varphi_2, \varphi_3$	33
Disturbance recording	34
Fault locator	35
Thermal capacity used	
Cooling time constant	37
Operating time before tripping	
Waiting time after tripping	38
Running hours counter and operating time	
Starting current and starting/overload time	39
Number of starts before inhibition	
Start inhibit time delay	40
Cumulative breaking current and number of operations	41
Operating time	
Charging time	42
VT supervision	43
CT supervision	45

The general settings define the characteristics of the measurement sensors connected to Sepam and determine the performance of the metering and protection functions used. They are accessed via the SFT2841 setting software General Characteristics tab.

Nota : You must use an interface ACE990 with a core balance CT other than a CSH120, CSH200 or CSH300 even if this core balance CT has the same transformation ratio than a CSH120, CSH200 or CSH300.

General settings		Selection	Setting range
In	Rated phase current (sensor primary current)	2 or 3 CT 1 A / 5 A	1 A to 6250 A
Ib	Base current, according to rated power of equipment ⁽²⁾	3 LPCTs	25 A to 3150 A ⁽¹⁾ 0.2 In to 1.3 In
In0	Rated residual current	Sum of 3 phase currents	See In rated phase current
		CSH120, CSH200, CSH300 core balance CT	2 A, 5 A or 20 A rating
		1 A/5 A CT	1 A to 6250 A (In0 = In)
		1 A/5 A CT Sensitivity x 10	0.1 A to 625 A (In0 = In/10)
		ACE990 + core balance CT other than CSH120, CSH200 or CSH300: the core balance CT ratio 1/n must be such that 50 ≤ n ≤ 1500)	According to current monitored and use of ACE990
Unp	Rated primary phase-to-phase voltage (Vnp: rated primary phase-to-neutral voltage Vnp = Unp/√3)		220 V to 250 kV
Uns	Rated secondary phase-to-phase voltage	3 VTs: V1, V2, V3 2 VTs: U21, U32 1 VT: V1	90 V to 230 V in steps of 1 V 90 V to 120 V in steps of 1 V 90 V to 120 V in steps of 1 V
Uns0	Secondary zero sequence voltage for primary zero sequence voltage Unp/√3		Uns/3 or Uns/√3
	Rated frequency		50 Hz or 60 Hz
	Integration period (for demand current and peak demand current and power)		5, 10, 15, 30, 60 mn
	Pulse-type accumulated energy meter	Increments active energy	0.1 kW.h to 5 MW.h
		Increments reactive energy	0.1 kvar.h to 5 Mvar.h

⁽¹⁾ In values for LPCT, in Amps: 25, 50, 100, 125, 133, 200, 250, 320, 400, 500, 630, 666, 1000, 1600, 2000, 3150.

⁽²⁾ Even if the value is within the range, it has to be rounded according to the setting step of 1 or 10A (i.e.: Ib = 12.2A → 13A).

Functions	Measurement range	Accuracy ⁽¹⁾	MSA141	Saving
Metering				
Phase current	0.1 to 40 In ⁽³⁾	±0.5 %	■	
Residual current	Calculated	0.1 to 40 In	■	
	Measured	0.1 to 20 In0	■	
Demand current	0.1 to 40 In	±0.5 %		
Peak demand current	0.1 to 40 In	±0.5 %		□
Phase-to-phase voltage	0.06 to 1.2 Unp	±0.5 %	■	
Phase-to-neutral voltage	0.06 to 1.2 Vnp	±0.5 %	■	
Residual voltage	0.04 to 3 Vnp	±1 %		
Positive sequence voltage	0.05 to 1.2 Vnp	±2 %		
Negative sequence voltage	0.05 to 1.2 Vnp	±2 %		
Frequency	25 to 65 Hz	±0.02 Hz	■	
Active power	0.015 Sn ⁽²⁾ to 999 MW	±1 %	■	
Reactive power	0.015 Sn ⁽²⁾ to 999 Mvar	±1 %	■	
Apparent power	0.015 Sn ⁽²⁾ to 999 MVA	±1 %	■	
Peak demand active power	0.015 Sn ⁽²⁾ to 999 MW	±1 %		□
Peak demand reactive power	0.015 Sn ⁽²⁾ to 999 Mvar	±1 %		□
Power factor	-1 to +1 (CAP/IND)	±1 %		
Calculated active energy	0 to 2.1.10 ⁸ MW.h	±1 % ±1 digit		□
Calculated reactive energy	0 to 2.1.10 ⁸ Mvar.h	±1 % ±1 digit		□
Temperature	-30 to +200 °C or -22 to +392 °F	±1 °C from +20 to +140 °C	■	
Network diagnosis assistance				
Tripping context				□
Phase tripping current	0.1 to 40 In	±5 %		□
Earth fault tripping current	0.1 to 20 In0	±5 %		□
Negative sequence / unbalance	10 to 500 % of Ib	±2 %		
Peak demand negative sequence and positive sequence current ratio	1 to 500 %	±2 %		
Phase displacement φ0 (between V0 and I0)	0 to 359°	±2°		
Phase displacement φ1, φ2, φ3 (between V and I)	0 to 359°	±2°		
Disturbance recording				□
Fault locator	Fault location	0 to 99.99 km or 0 to 62.13 mi	±2 %	
	Fault resistance	0 to 999.9 Ω	±10 %	
Machine operating assistance				
Thermal capacity used	0 to 800 % (100 % for I phase = Ib)	±1 %	■	□
Remaining operating time before overload tripping	0 to 999 mn	±1 mn		
Waiting time after overload tripping	0 to 999 mn	±1 mn		
Running hours counter / operating time	0 to 65535 hours	±1 % or ±0.5 h		□
Starting current	1.2 Ib to 24 In	±5 %		□
Starting time	0 to 300 s	±300 ms		□
Number of starts before inhibition	0 to 60	1		
Start inhibit time	0 to 360 mn	±1 mn		
Cooling time constant	5 to 600 mn	±5 mn		
Switchgear diagnosis assistance				
Cumulative breaking current	0 to 65535 kA ²	±10 %		□
Number of operations	0 to 4.10 ⁹	1		□
Operating time	20 to 100 ms	±1 ms		□
Charging time	1 to 20 s	±0.5 s		□

■ available on MSA141 analog output module, according to setup.

□ saved in the event of auxiliary supply outage.

(1) Typical accuracy, see details on subsequent pages.

(2) Sn: apparent power, = √3 · Unp · In.

(3) Measurement up to 0.02 In for information purpose.

Phase current

Operation

This function gives the RMS value of the phase currents:

- I1: phase 1 current
- I2: phase 2 current
- I3: phase 3 current.

It is based on RMS current measurement and takes into account harmonics up to number 17.

Readout

The measurements may be accessed via:

- the advanced UMI display unit by pressing the  key
- the display of a PC with the SFT2841 software
- the communication link
- an analog converter with the MSA141 option.

Characteristics

Measurement range	0.1 to 1.5 In ⁽¹⁾
Unit	A or kA
Accuracy	±0.5 % typical ⁽²⁾ ±2 % from 0.3 to 1.5 In ±5 % if < 0.3 In
Display format ⁽³⁾	3 significant digits
Resolution	0.1 A
Refresh interval	1 second (typical)

⁽¹⁾ In rated current set in the general settings.

⁽²⁾ At In, in reference conditions (IEC 60255-6).

⁽³⁾ Display of values: 0.02 to 40 In.

Residual current

Operation

This operation gives the RMS value of the residual current I0.

It is based on measurement of the fundamental component.

Readout

The residual current measured (I0), and the residual current calculated by the sum of the phase currents (I0Σ) may be accessed via:

- the advanced UMI display unit by pressing the  key
- the display of a PC with the SFT2841 software
- the communication link
- an analog converter with the MSA141 option.

Characteristics

Measurement range		
Connection to 3 phase CTs:		0.1 to 1.5 In0 ⁽¹⁾
Connection to 1 CT		0.1 to 1.5 In0 ⁽¹⁾ ⁽³⁾
Connection to core balance CT with ACE990		0.1 to 1.5 In0 ⁽¹⁾
Connection to CSH residual current sensor	2 A rating	0.2 to 3 A ⁽³⁾
	5 A rating	0.5 to 7.5 A ⁽³⁾
	20 A rating	2 to 30 A ⁽³⁾
Unit		A or kA
Accuracy ⁽²⁾		±1 % typical at In0 ±2 % from 0.3 to 1.5 In0 ±5 % if < 0.3 In0
Display format		3 significant digits
Resolution		0.1 A
Refresh interval		1 second (typical)

⁽¹⁾ In0 rated current set in the general settings.

⁽²⁾ In reference conditions (IEC 60255-6), excluding sensor accuracy.

⁽³⁾ In0 = InCT or In0 = InCT/10 according to setting.

Operation

This function gives:

- the average RMS current for each phase that has been obtained for each integration interval
- the greatest average RMS current value for each phase that has been obtained since the last reset.

The values are refreshed after each "integration interval", an interval that may be set from 5 to 60 mn, and are saved in the event of a power failure.

Readout

The measurements may be accessed via:

- the advanced UMI display unit by pressing the  key
- the display of a PC with the SFT2841 software
- the communication link.

Resetting to zero

- press the  key on the advanced UMI display unit when a peak demand current is displayed
- via the clear command in the SFT2841 software
- via the communication link (remote control order TC6).

Characteristics

Measurement range	0.1 to 1.5 In ⁽¹⁾
Unit	A or kA
Accuracy	±0.5 % typical ⁽²⁾ ±2 % from 0.3 to 1.5 In ±5 % if < 0.3 In
Display format ⁽³⁾	3 significant digits
Resolution	0.1 A
Integration period	5, 10, 15, 30, 60 minutes

⁽¹⁾ In rated current set in the general settings.

⁽²⁾ At In, in reference conditions (IEC 60255-6).

⁽³⁾ Display of values: 0.02 to 40 In.

TS/TC equivalence for each protocol

Modbus	DNP3	IEC 60870-5-103	IEC 61850
TC	Binary Output	ASDU, FUN, INF	LN.DO.DA
TC6	BO12	-	MSTA1.RsMaxA.ctlVal

Phase-to-phase voltage

Operation

This function gives the RMS value of the 50 or 60 Hz component of phase-to-phase voltages (according to voltage sensor connections):

- U21: voltage between phases 2 and 1
- U32: voltage between phases 3 and 2
- U13: voltage between phases 1 and 3.

It is based on measurement of the fundamental component.

Readout

The measurements may be accessed via:

- the advanced UMI display unit by pressing the  key
- the display of a PC with the SFT2841 software
- the communication link
- an analog converter with the MSA141 option.

Characteristics

Measurement range	0.06 to 1.2 Unp ⁽¹⁾
Unit	V or kV
Accuracy	±0.5 % typical ⁽²⁾ ±1 % from 0.5 to 1.2 Unp ±2 % from 0.06 to 0.5 Unp
Display format	3 significant digits
Resolution	1 V
Refresh interval	1 second (typical)

⁽¹⁾ Un nominal rating set in the general settings.

⁽²⁾ At Unp, in reference conditions (IEC 60255-6).

Phase-to-neutral voltage

Operation

This function gives the RMS value of the 50 or 60 Hz component of phase-to-neutral voltages:

- V1: phase 1 phase-to-neutral voltage
- V2: phase 2 phase-to-neutral voltage
- V3: phase 3 phase-to-neutral voltage.

It is based on measurement of the fundamental component.

Readout

The measurements may be accessed via:

- the advanced UMI display unit by pressing the  key
- the display of a PC with the SFT2841 software
- the communication link
- an analog converter with the MSA141 option.

Characteristics

Measurement range	0.06 to 1.2 Vnp ⁽¹⁾
Unit	V or kV
Accuracy	±0.5 % typical ⁽²⁾ ±1 % from 0.5 to 1.2 Vnp ±2 % from 0.06 to 0.5 Vnp
Display format	3 significant digits
Resolution	1 V
Refresh interval	1 second (typical)

⁽¹⁾ Vnp: primary rated phase-to-neutral voltage ($V_{np} = Unp/\sqrt{3}$).

⁽²⁾ At Vnp in reference conditions (IEC 60255-6).

Residual voltage

Operation

This function gives the value of the residual voltage $V_0 = (V_1 + V_2 + V_3)$.

V_0 is measured:

- by taking the internal sum of the 3 phase voltages
- by an open star / delta VT.

It is based on measurement of the fundamental component.

Readout

The measurement may be accessed via:

- the advanced UMI display unit by pressing the  key
- the display of a PC with the SFT2841 software
- the communication link.

Characteristics

Measurement range	0.04 V_{np} to 3 V_{np} ⁽¹⁾
Unit	V or kV
Accuracy	±1 % from 0.5 to 3 V_{np} ±2 % from 0.05 to 0.5 V_{np} ±5 % from 0.04 to 0.05 V_{np}
Display format	3 significant digits
Resolution	1 V
Refresh interval	1 second (typical)

⁽¹⁾ V_{np} : primary rated phase-to-neutral voltage ($V_{np} = U_{np}/\sqrt{3}$).

Positive sequence voltage

Operation

This function gives the calculated value of the positive sequence voltage V_d .

Readout

The measurement may be accessed via:

- the advanced UMI display unit by pressing the  key
- the display of a PC with the SFT2841 software
- the communication link.

Characteristics

Measurement range	0.05 to 1.2 V_{np} ⁽¹⁾
Unit	V or kV
Accuracy	±2 % at V_{np}
Display format	3 significant digits
Resolution	1 V
Refresh interval	1 second (typical)

⁽¹⁾ V_{np} : primary rated phase-to-neutral voltage ($V_{np} = U_{np}/\sqrt{3}$).

Negative sequence voltage

Operation

This function gives the calculated value of the negative sequence voltage V_i .

Readout

The measurement may be accessed via:

- the advanced UMI display unit by pressing the  key
- the display of a PC with the SFT2841 software
- the communication link.

Characteristics

Measurement range	0.05 to 1.2 V_{np} ⁽¹⁾
Unit	V or kV
Accuracy	±2 % at V_{np}
Display format	3 significant digits
Resolution	1 V
Refresh interval	1 second (typical)

(1) V_{np} : primary rated phase-to-neutral voltage ($V_{np} = U_{np}/\sqrt{3}$).

Frequency

Operation

This function gives the frequency value.

Frequency is measured via the following:

- based on U21, if only one phase-to-phase voltage is connected to the Sepam
- based on positive sequence voltage, if the Sepam includes U21 and U32 measurements.

Frequency is not measured if:

- the voltage U21 or positive sequence voltage V_d is less than 40 % of U_n
- the frequency is outside the measurement range.

Readout

The measurement may be accessed via:

- the advanced UMI display unit by pressing the  key
- the display of a PC with the SFT2841 software
- the communication link
- an analog converter with the MSA141 option.

Characteristics

Rated frequency	50 Hz, 60 Hz
Range	25 to 65 Hz
Accuracy ⁽¹⁾	±0.02 Hz
Display format	3 significant digits
Resolution	On SFT2841: 0.01 Hz On Sepam display: 0.1 Hz
Refresh interval	1 second (typical)

(1) At U_{np} in reference conditions (IEC 60255-6).

Operation

This function gives the power values:

- P active power = $\sqrt{3} \cdot U \cdot I \cdot \cos \varphi$
- Q reactive power = $\sqrt{3} \cdot U \cdot I \cdot \sin \varphi$
- S apparent power = $\sqrt{3} \cdot U \cdot I$

The function measures the active and reactive power in 3-wire 3-phase arrangements by means of the two wattmeter method. The powers are obtained based on the phase-to-phase voltages U21 and U32 and the phase currents I1 and I3.

When only the voltage U21 is connected, P and Q are calculated assuming that the system voltage is balanced.

According to standard practice, it is considered that:

- for the outgoing circuit (1):
- power exported by the busbar is positive
- power supplied to the busbar is negative

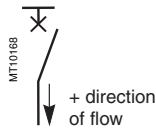

- for the incoming circuit (1):
- power supplied to the busbar is positive
- power exported by the busbar is negative.

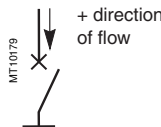

Readout

The measurements may be accessed via:

- the advanced UMI display unit by pressing the  key
- the display of a PC with the SFT2841 software
- the communication link
- an analog converter with the MSA141 option.

(1) Choice to be set in the general settings.

Characteristics

	Active power P	Reactive power Q
Measurement range	$\pm(1.5 \% S_n \text{ at } 999 \text{ MW})^{(1)}$	$\pm(1.5 \% S_n \text{ at } 999 \text{ Mvar})^{(1)}$
Unit	kW, MW	kvar, Mvar
Accuracy	$\pm 1 \% \text{ typical }^{(2)}$	$\pm 1 \% \text{ typical }^{(2)}$
Display format	3 significant digits	3 significant digits
Resolution	0.1 kW	0.1 kvar
Refresh interval	1 second (typical)	1 second (typical)

	Apparent power S
Measurement range	$1.5 \% S_n \text{ at } 999 \text{ MVA }^{(1)}$
Unit	kVA, MVA
Accuracy	$\pm 1 \% \text{ typical }^{(2)}$
Display format	3 significant digits
Resolution	0.1 kVA
Refresh interval	1 second (typical)

(1) $S_n = \sqrt{3} \cdot U_{np} \cdot I_n$.

(2) At $I_n, U_{np}, \cos \varphi > 0.8$ in reference conditions (IEC 60255-6).

Peak demand active and reactive power Power factor (cos φ)

2

Peak demand active and reactive power

Operation

This function gives the greatest average active or reactive power value since the last reset.

The values are refreshed after each "integration interval", an interval that may be set from 5 to 60 mn (common interval with peak demand phase currents). The values are saved in the event of a power failure.

Readout

The measurements may be accessed via:

- the advanced UMI display unit by pressing the  key
- the display of a PC with the SFT2841 software
- the communication link.

Resetting to zero

- press the  key on the advanced UMI display unit when a peak demand is displayed
- via the "clear" command in the SFT2841 software
- via the communication link (remote control order TC6).

Characteristics

	Active power P	Reactive power Q
Measurement range	$\pm(1.5 \% S_n \text{ at } 999 \text{ MW})^{(1)}$	$\pm(1.5 \% S_n \text{ at } 999 \text{ Mvar})^{(1)}$
Unit	kW, MW	kvar, Mvar
Accuracy	$\pm 1 \% \text{ typical }^{(2)}$	$\pm 1 \% \text{ typical }^{(2)}$
Display format	3 significant digits	3 significant digits
Resolution	0.1 kW	0.1 kvar
Integration interval	5, 10, 15, 30, 60 mn	5, 10, 15, 30, 60 mn

(1) $S_n = \sqrt{3} Unp.In.$

(2) At $I_n, Unp, \cos \varphi > 0.8$ in reference conditions (IEC 60255-6).

TS/TC equivalence for each protocol

Modbus	DNP3	IEC 60870-5-103	IEC 61850
TC	Binary Output	ASDU, FUN, INF	LN.DO.DA
TC6	BO12	-	MSTA1.RsMaxA.ctlVal

Power factor (cos φ)

Operation

The power factor is defined by:

$$\cos \varphi = P / \sqrt{P^2 + Q^2}$$

It expresses the phase displacement between the phase currents and phase-to-neutral voltages.

The + and - signs and IND (inductive) and CAP (capacitive) indications give the direction of power flow and the type of load (according IEC convention).

Readout

The measurement may be accessed via:

- the advanced UMI display unit by pressing the  key
- the display of a PC with the SFT2841 software
- the communication link.

Characteristics

Measurement range	-1 to 1 IND/CAP
Accuracy ⁽¹⁾	$\pm 0.01 \text{ typical}$
Display format	3 significant digits
Resolution	0.01
Refresh interval	1 second (typical)

(1) At $I_n, Unp, \cos \varphi > 0.8$ in reference conditions (IEC 60255-6).

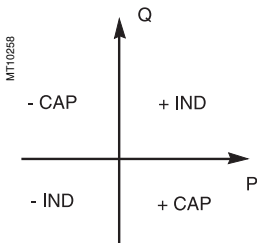
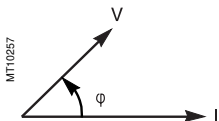

IEC convention.

Accumulated active and reactive energy

Operation

This function gives the following for the active and reactive energy values:

- accumulated energy conveyed in one direction
- accumulated energy conveyed in the other direction.

It is based on measurement of the fundamental component.

The accumulated energy values are saved in the event of a power failure.

Readout

The measurements may be accessed via:

- the advanced UMI display unit by pressing the  key
- the display of a PC with the SFT2841 software
- the communication link.

Characteristics

	Active energy	Reactive energy
Metering capacity	0 to 2.1 10 ⁹ MW.h	0 to 2.1 10 ⁸ Mvar.h
Unit	MW.h	Mvar.h
Accuracy	±1 % typical ⁽¹⁾	±1 % typical ⁽¹⁾
Display format	10 significant digits	10 significant digits
Resolution	0.1 MW.h	0.1 Mvar.h

(1) At I_n , Unp , $\cos \varphi > 0.8$ in reference conditions (IEC 60255-6).

Accumulated active and reactive energy by pulse metering

Operation

This function is used for energy metering via logic inputs. Energy incrementing is associated with each input (one of the general parameters to be set). Each input pulse increments the meter. 4 inputs and 4 accumulated energy metering options are available:

- positive and negative active energy
- positive and negative reactive energy.

The accumulated active and reactive energy values are saved in the event of a power failure.

Readout

- the display of a PC with the SFT2841 software
- the communication link.

Characteristics

	Active energy	Reactive energy
Metering capacity	0 to 2.1 10 ⁹ MW.h	0 to 2.1 10 ⁸ Mvar.h
Unit	MW.h	Mvar.h
Display format	10 significant digits	10 significant digits
Resolution	0.1 MW.h	0.1 Mvar.h
Increment	0.1 kW.h to 5 MW	0.1 kvar.h to 5 Mvar.h
Impulse	15 ms min.	15 ms min.

Operation

This function gives the temperature value measured by resistance temperature detectors (RTDs):

- platinum Pt100 (100 Ω at 0 °C or 32 °F) in accordance with the IEC 60751 and DIN 43760 standards
- nickel 100 Ω or 120 Ω (at 0 °C or 32 °F).

Each RTD channel gives one measurement:

$$t_x = \text{RTD} \times \text{temperature}$$

The function also indicates RTD faults:

- RTD disconnected ($t_x > 205 \text{ °C}$ or $t > 401 \text{ °F}$)
- RTD shorted ($t_x < -35 \text{ °C}$ or $t < -31 \text{ °F}$).

In the event of a fault, display of the value is inhibited.

The associated monitoring function generates a maintenance alarm.

Readout

The measurement may be accessed via:

- the advanced UMI display unit by pressing the  key, in °C or in °F
- the display of a PC with the SFT2841 software
- the communication link
- an analog converter with the MSA141 option.

Characteristics

Range	-30 °C to +200 °C	-22 °F to +392 °F
Resolution	1 °C	1 °F
Accuracy ⁽¹⁾	±1 °C from +20 to +140 °C	±1.8 °F from +68 °F to +284 °F
	±2 °C from -30 to +20 °C	±3.6 °F from -22 °F to +68 °F
	±2 °C from +140 to +200 °C	±3.6 °F from +284 °F to +392 °F
Refresh interval	5 seconds (typical)	

Accuracy derating according to wiring:

See "Installation of MET148-2 module" page 228.

Tripping context

Operation

This function gives the values of physical units at the time of tripping to enable analysis of the cause of the fault. The values available, accessible via the advanced UMI or the SFT2841 software tool are as follows:

- tripping currents
- residual current measured on I0 input
- residual current calculated on the sum of the phase currents
- positive sequence current
- negative sequence current
- phase-to-phase voltages
- phase-to-neutral voltages
- residual voltage
- positive sequence voltage
- negative sequence voltage
- frequency
- active power
- reactive power
- fault location
- fault resistance
- faulty phase(s).

The values corresponding to the last five trips are stored with the date and time of the trip. They are saved in the event of a power failure.

Readout

The measurements may be accessed via:

- the advanced UMI display unit by pressing the Σ_r key
- the display of a PC with the SFT2841 software
- the communication link.

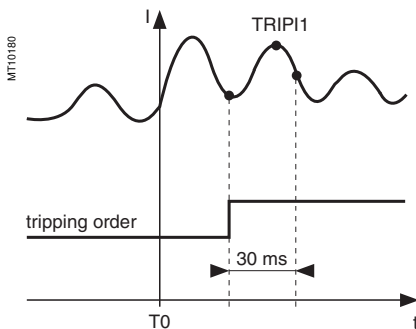

Tripping current (TRIP1) acquisition.

Tripping current

Operation

This function gives the RMS value of currents at the prospective time of the last trip:

- TRIPI1: phase 1 current
- TRIPI2: phase 2 current
- TRIPI3: phase 3 current.

It is based on measurement of the fundamental component.

This measurement is defined as the maximum RMS value measured during a 30 ms interval after the activation of the tripping contact on output O1.

Readout

The measurements may be accessed via:

- the advanced UMI display unit by pressing the Σ_r key
- the display of a PC with the SFT2841 software
- the communication link.

Characteristics

Measurement range	0.1 to 40 In ⁽¹⁾
Unit	A or kA
Accuracy	±5 % ±1 digit
Display format	3 significant digits
Resolution	0.1 A

(1) In rated current set in the general settings.

Negative sequence / unbalance Peak demand negative sequence and positive sequence current ratio

Negative sequence / unbalance

Operation

This function gives the negative sequence component: $T = I_i/I_b$

The negative sequence current is determined based on the phase currents:

- 3 phases

$$\vec{I}_i = \frac{1}{3} \times (\vec{I}_1 + a^2 \vec{I}_2 + a \vec{I}_3)$$

$$\text{with } a = e^{j\frac{2\pi}{3}}$$

- 2 phases

$$\vec{I}_i = \frac{1}{\sqrt{3}} \times (\vec{I}_1 - a^2 \vec{I}_3)$$

$$\text{with } a = e^{j\frac{2\pi}{3}}$$

These 2 formulas are equivalent when there is no earth fault.

Readout

The measurements may be accessed via:

- the advanced UMI display unit by pressing the  key
- the display of a PC with the SFT2841 software
- the communication link.

Characteristics

Measurement range	10 to 500 %
Unit	% Ib
Accuracy	±2 %
Display format	3 significant digits
Resolution	1 %
Refresh interval	1 second (typical)

Peak demand negative sequence and positive sequence current ratio

Operation

This peak demand meter is used as an aid to setting the set point for the broken conductor detection protection function (ANSI code 46BC).

It provides the highest value of the negative sequence and positive sequence current ratio I_i/I_d since the last reset.

A phase current measurement with 3 CTs is mandatory for this calculation.

The negative sequence current is given by:

$$\vec{I}_i = \frac{1}{3} \times (\vec{I}_1 + a^2 \vec{I}_2 + a \vec{I}_3)$$

The positive sequence current is given by:

$$\vec{I}_d = \frac{1}{3} \times (\vec{I}_1 + a \vec{I}_2 + a^2 \vec{I}_3)$$

$$\text{where } a = e^{j\frac{2\pi}{3}}$$

Readout

The measurements may be accessed via:

- the display of a PC with the SFT2841 software
- the Modbus communication link.

Resetting to zero

Only via the "Reset I_i/I_d peak demand meter" command on the "network diagnosis" display of the SFT2841 software.

Characteristics

Measuring range	1 to 500%
Accuracy	±2%
Resolution	1%
Refresh period	1 second (typical)

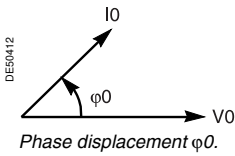

Phase displacement φ_0

Operation

This function gives the phase displacement measured between the residual voltage and residual current in the trigonometric sense (see diagram). The measurement is useful during commissioning to check that the directional earth fault protection unit is connected correctly.

Two values are available:

- φ_0 , angle with measured I_0
- $\varphi_0\Sigma$, angle with I_0 calculated by sum of phase currents.

Readout

The measurements may be accessed via:

- the advanced UMI display unit by pressing the  key
- the display of a PC with the SFT2841 software
- the communication link.

Characteristics

Measurement range	0 to 359°
Resolution	1°
Accuracy	±2°
Refresh interval	2 seconds (typical)

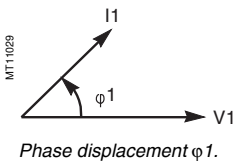

Phase displacement $\varphi_1, \varphi_2, \varphi_3$

Operation

This function gives the phase displacement between the V_1, V_2, V_3 voltages and I_1, I_2, I_3 currents respectively, in the trigonometric sense (see diagram). The measurements are used when Sepam is commissioned to check that the voltage and current inputs are wired correctly. It does not operate when only the U_{21} voltage is connected to Sepam.

Readout

The measurements may be accessed via:

- the advanced UMI display unit by pressing the  key
- the display of a PC with the SFT2841 software
- the communication link.

Characteristics

Measurement range	0 to 359°
Resolution	1°
Accuracy	±2°
Refresh interval	2 seconds (typical)

Operation

This function is used to record analog signal and logical states.
Record storage is activated according to parameter setting by a triggering event (see Control and monitoring functions - Disturbance recording triggering).
The stored event begins before the triggering event and continues afterwards.
The record comprises the following information:

- values sampled from the different signals
- date
- characteristics of the recorded channels.

The duration and number of records may be set using the SFT2841 software tool.
The files are recorded in FIFO (First In First Out) type shift storage. When the maximum number of records is reached, the oldest record is erased when a new record is triggered.
The disturbance records are saved for a minimum of 48 hours and typically for approximately 100 hours when the Sepam is switched off.

Transfer

Files may be transferred locally or remotely:

- locally: using a PC which is connected to the front panel connector and has the SFT2841 software tool
- remotely: using a software tool specific to the remote monitoring and control system.

Recovery

The signals are recovered from a record by means of the SFT2826 software tool.

Principle

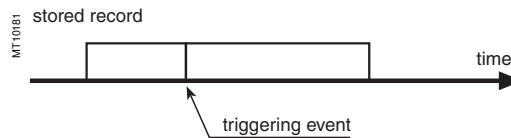

Characteristics

Record content	Set-up file: date, channel characteristics, measuring chain transformer ratio Sample file: 12 values per period/recorded signal
Analog signals ⁽²⁾ recorded	4 current channels (I1, I2, I3, I0) 3 voltage channels (V1, V2, V3 or U21, U32, V0)
Logical states recorded	10 logic inputs, logic outputs O1 to O4, pick-up, 1 data item configurable by the logic equation editor
Number of records stored	1 to 19
Total duration of a record	1 s to 10 s The total records plus one should not exceed 20 s at 50 Hz and 16 s at 60 Hz. Examples (at 50 Hz): 1 x 10 s record 3 x 5 s records 19 x 1 s records
Periods before triggering event ⁽¹⁾	0 to 99 periods
File format	COMTRADE 97

⁽¹⁾ According to parameter setting with the SFT2841 software and factory-set to 36 periods.

⁽²⁾ According to the type of sensors.

Description

The Fault locator function calculates the location and resistance of a presumed fault in a medium-voltage network.

The fault location is calculated for faults downstream of the point where the protection relay is installed, typically on the incoming feeder of an installation on a network comprising several feeders.

- The single-phase fault locator is associated with the ANSI 50N/51N and ANSI 67N protection functions.

- The multi-phase fault locator is associated with the ANSI 50/51 and ANSI 67 protection functions.

Only the protection function units configured for circuit breaker tripping can activate the Fault locator function.

After calculation, the following data is recorded in the tripping context:

- fault location (in km or in mi)

- fault resistance (in Ω)

- faulty phase(s)

This data may be accessed with the other measurements in the tripping contexts via:

- the display of a PC with the SFT2841 software

- the communication link.

See "Tripping context Tripping current", page 31.

Field of application

The Fault locator function is suitable for:

- medium-voltage networks:

- overhead, made up of 100% overhead lines

- or mixed, made up of 0 to 30% underground cables and 70 to 100% overhead lines

- with neutral to earth connection:

- direct

- with earthing resistor and fault current > 150 A

- with R-X impedance in series, with ratio $R/X > 3$

The Fault locator function gives incorrect results when it is applied to underground networks or networks with an isolated or compensated neutral.

The Fault locator function can only be activated if the rated primary voltage (Unp) is set between 5.5 kV and 36 kV.

Operation

The fault location is calculated using symmetrical components. These are calculated using the values of the 3 currents and 3 phase-to-earth voltages:

- recorded during healthy operation, before the appearance of the fault

- recorded in steady state fault conditions.

The main assumption of this calculation relies on simplification of the diagram of the feeder monitored via the protection. The tree diagram comprising a variety of conductors and loads is replaced by an equivalent simplified diagram which contains no more than one type of conductor and one load connected at the end of the line.

The function determines the type of fault and the phases affected by the fault, then calculates the fault location using a patented algorithm.

Block diagram

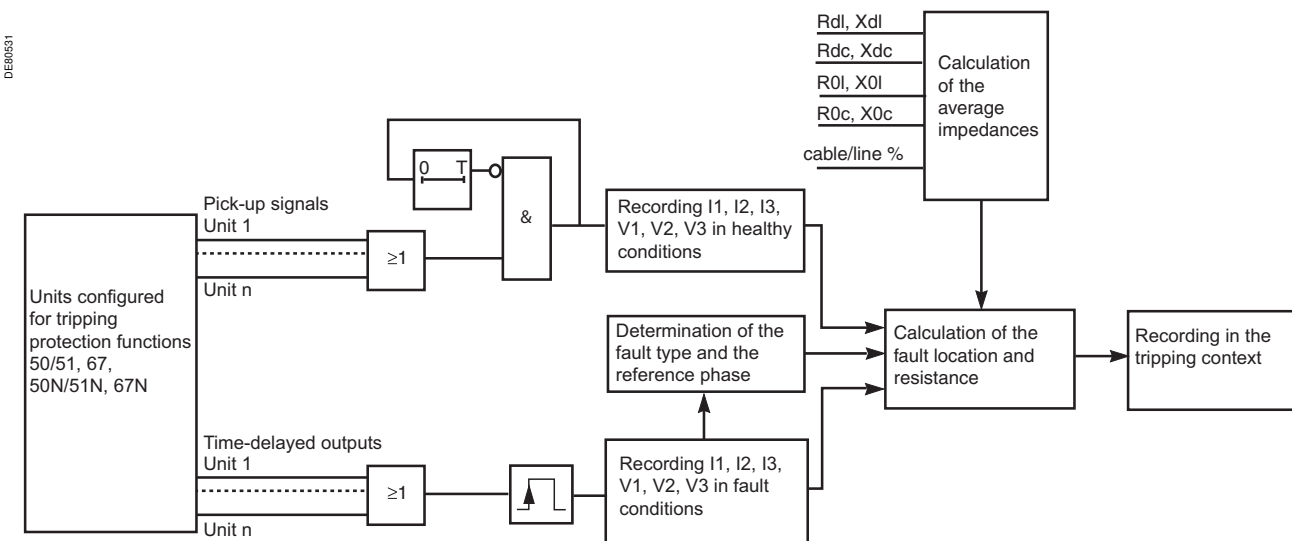

Protection setting parameters

The protection setting parameters are:

- time delay T indicating the time it takes to establish healthy conditions after the last instantaneous "pick-up" signal.

Time delay T avoids having to record the values measured in fault conditions as healthy values during, for example, a circuit breaker reclosing cycle.

- the percentage of cable in the relevant feeder
- symmetrical impedances of conductors in /km or in /mi:
 - Rdl, Xdl: resistance and reactance per unit length of the positive sequence diagram of overhead line conductors
 - Rdc, Xdc: resistance and reactance per unit length of the positive sequence diagram of underground cable conductors
 - R0l, X0l: resistance and reactance per unit length of the zero sequence diagram of overhead line conductors
 - R0c, X0c: resistance and reactance per unit length of the zero sequence diagram of underground cable conductors.

Average impedance values are given in the table below. They were calculated taking the average of the IEC 60909 answers and the calculations statistics.

Average impedance values depending on the type of conductor in Ω/km (Ω/mi)				
Cable	Rdc	Xdc	R0c	X0c
Multi-core	0.39 (0.63)	0.14 (0.225)	2 (3.22)	0.4 (0.64)
Single-phase	0.06 (0.1)	0.11 (0.18)	0.99 (1.6)	1.41 (1.83)
Line	Rdl	Xdl	R0l	X0l
Single-core	0.68 (1.1)	0.372 (0.6)	0.828 (1.33)	1.696 (2.73)

Characteristics

Time delay T	
Setting	1 s to 99 min
Percentage of cable in the relevant feeder	
Setting	0 to 30%
Symmetrical impedance of conductors	
Positive sequence resistance of Rdl lines	0.001 to 10 Ω/km or 0.0016 to 16.1 Ω/mi
Positive sequence reactance of Xdl lines	0.001 to 10 Ω/km or 0.0016 to 16.1 Ω/mi
Positive sequence resistance of Rdc cables	0.001 to 10 Ω/km or 0.0016 to 16.1 Ω/mi
Positive sequence reactance of Xdc cables	0.001 to 10 Ω/km or 0.0016 to 16.1 Ω/mi
Zero sequence resistance of R0l lines	0.001 to 10 Ω/km or 0.0016 to 16.1 Ω/mi
Zero sequence reactance of X0l lines	0.001 to 10 Ω/km or 0.0016 to 16.1 Ω/mi
Zero sequence resistance of R0c cables	0.001 to 10 Ω/km or 0.0016 to 16.1 Ω/mi
Zero sequence reactance of X0c cables	0.001 to 10 Ω/km or 0.0016 to 16.1 Ω/mi

Indicative performance

The relative error on the fault location is calculated

- in relation to the longest path on the feeder:

$$\varepsilon = \frac{D_{\text{real}} - D_{\text{estimated}}}{D_{\text{longest}}} 100 \%$$

- in the following conditions:

- load supplied on the feeder less than 4 MVA
- fault resistance less than 150 Ω.

Accuracy of calculation of the single-phase fault location	
Feeder type	Typical error
Overhead	±1.02%
Mixed (30% cable)	±7%
Accuracy of calculation of the multi-phase fault location	
Feeder type	Typical error
Overhead	±0.73%
Mixed (30% cable)	±2.73%

Thermal capacity used

Operation

The thermal capacity used is calculated by the thermal protection function. The thermal capacity used is related to the load. The thermal capacity used measurement is given as a percentage of the rated thermal capacity.

Saving of thermal capacity used

The thermal capacity used is saved in the event of a Sepam power cut. The saved value is used again after a Sepam power outage.

Readout

The measurements may be accessed via:

- the advanced UMI display unit by pressing the  key
- the display of a PC with the SFT2841 software
- the communication link
- an analog converter with the MSA141 option.

Characteristics

Measurement range	0 to 800 %
Unit	%
Display format	3 significant digits
Resolution	1 %
Refresh interval	1 second (typical)

Cooling time constant

Operation

The cooling time constant T_2 of the equipment being monitored (transformer, motor or generator) is estimated by the thermal overload protection function. It is calculated each time the equipment operates for a sufficiently long period, followed by a shutdown ($I < 0.1 I_b$) and temperature stabilization phase. The calculation is based on the temperature measured by RTDs 1, 2 and 3 (stator sensors for motors and generators) or by RTDs 1, 3 and 5 (primary winding sensors for transformers). For greater accuracy, it is advisable for the ambient temperature to be measured by RTD 8.

If "other applications" is chosen in the RTD assignment table, T_2 is not estimated. Two measurements are available, one for each thermal operating rate of the monitored equipment.

Readout

The measurements may be accessed via:

- the advanced UMI display unit by pressing the  key
- the display of a PC with the SFT2841 software
- the communication link.

Characteristics

Measurement range	5 to 600 mn
Unit	mn
Resolution	1 mn
Accuracy	±5 %
Display format	3 significant digits

Remaining operating time before overload tripping

Operation

The time is calculated by the thermal protection function. It depends on the thermal capacity used.

Readout

The measurements may be accessed via:

- the advanced UMI display unit by pressing the  key
- the display of a PC with the SFT2841 software
- the communication link.

Characteristics

Measurement range	0 to 999 mn
Unit	mn
Display format	3 significant digits
Resolution	1 mn
Refresh interval	1 second (typical)

Waiting time after overload tripping

Operation

The time is calculated by the thermal protection function. It depends on the thermal capacity used.

Readout

The measurements may be accessed via:

- the advanced UMI display unit by pressing the  key
- the display of a PC with the SFT2841 software
- the communication link.

Characteristics

Measurement range	0 to 999 mn
Unit	mn
Display format	3 significant digits
Resolution	1 mn
Refresh period	1 second (typical)

Running hours counter and operating time

The counter gives the running total of time during which the protected device (motor, generator or transformer) has been operating ($I > 0.1 I_b$). The initial counter value may be modified using the SFT2841 software.

The counter is saved in the event of an auxiliary power failure.

Readout

The measurements may be accessed via:

- the advanced UMI display unit by pressing the  key
- the display of a PC with the SFT2841 software
- the communication link.

Characteristics

Range	0 to 65535
Unit	hours

Starting current and starting/overload time

Operation

The starting time is defined as follows:

- If the locked rotor/excessive starting time protection (ANSI code 48/51LR) is active, the starting time is the time separating the moment when one of the 3 phase currents exceeds I_s and the moment when the 3 currents drop back below I_s , I_s being the value of the current set point for protection function 48/51LR.
- If the locked rotor/excessive starting time protection (ANSI code 48/51LR) is not active, the starting time is the time separating the moment when one of the 3 phase currents exceeds $1.2 I_b$ and the moment when the 3 currents drop back below $1.2 I_b$. The maximum phase current obtained during this time corresponds to the starting/overload current.

Both values are saved in the event of an auxiliary power failure.

Readout

The measurements may be accessed via:

- the advanced UMI display unit by pressing the  key
- the display of a PC with the SFT2841 software
- the communication link.

Characteristics

Starting/overload time		
Measurement range		0 to 300 s
Unit		s or ms
Display format		3 significant digits
Resolution		10 ms or 1 digit
Refresh interval		1 second (typical)
Starting/overload current		
Measurement range	48/51LR active	I_s to $24 I_n^{(1)}$
	48/51LR inactive	$1.2 I_b$ to $24 I_n^{(1)}$
Unit		A or kA
Display format		3 significant digits
Resolution		0.1 A or 1 digit
Refresh interval		1 second (typical)

(1) Or 65.5 kA.

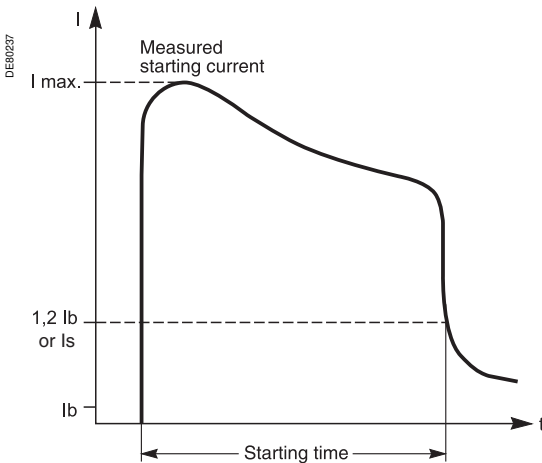

Number of starts before inhibition

Operation

The number of starts allowed before inhibition is calculated by the number of starts protection function (ANSI code 66).
The number of starts depends on the thermal state of the motor.

Readout

The measurement may be accessed via:

- the advanced UMI display unit by pressing the  key
- the display of a PC with the SFT2841 software
- the communication link.

Resetting to zero

The number of starts counters may be reset to zero as follows, after the entry of a password:

- on the advanced UMI display unit by pressing the  key
- on the display of a PC with the SFT2841 software
- the communication link (TC6).

Characteristics

Measurement range	0 to 60
Unit	none
Display format	3 significant digits
Resolution	1
Refresh interval	1 second (typical)

Start inhibit time delay

Operation

The start inhibit time only applies to the M40 and M41 motor applications. It depends on both the starts per hour protection (ANSI code 66) and the machine thermal overload protection (ANSI code 49 RMS) if they have been activated. This time expresses the waiting time until another start is allowed.

If at least one of these functions picks up, a "START INHIBIT" message informs the user that starting is not allowed.

Readout

The number of starts and waiting time may be accessed via:

- the advanced UMI display unit by pressing the  key
- the display of a PC with the SFT2841 software
- the communication link.

Characteristics

Measurement range	0 to 360 mn
Unit	mn
Display format	3 significant digits
Resolution	1 mn
Refresh interval	1 second (typical)

Cumulative breaking current

Operation

This function gives the cumulative breaking current in (kA)² for five current ranges. It is based on measurement of the fundamental component.

The current ranges displayed are:

- $0 < I < 2 I_n$
- $2 I_n < I < 5 I_n$
- $5 I_n < I < 10 I_n$
- $10 I_n < I < 40 I_n$
- $I > 40 I_n$.

This function gives the cumulative breaking current in (kA)² for five current ranges. Each value is saved in the event of an auxiliary power failure.

Refer to switchgear documentation for use of this information.

Number of operations

The function also gives the total number of breaking device operations.

It is activated by tripping orders (O1 relay).

The number of operations is saved in the event of an auxiliary power failure.

Readout

The measurements may be accessed via:

- the advanced UMI display unit by pressing the  key
- the display of a PC with the SFT2841 software
- the communication link.

The initial values may be introduced using the SFT2841 software tool to take into account the real state of a used breaking device.

Characteristics

Cumulative breaking current (kA) ²	
Range	0 to 65535 (kA) ²
Unit	primary (kA) ²
Resolution	1(kA) ²
Accuracy ⁽¹⁾	±10 % ±1 digit
Number of operations	
Range	0 to 65535

(1) At I_n , in reference conditions (IEC 60255-6).

Operating time

Operation

This function gives the value of the opening operating time of a breaking device ⁽¹⁾ and change of status of the device open position contact connected to the I11 input ⁽²⁾. The function is inhibited when the input is set for AC voltage ⁽³⁾. The value is saved in the event of an auxiliary power failure.

Readout

The measurement may be accessed via:

- the advanced UMI display unit by pressing the  key
- the display of a PC with the SFT2841 software
- the communication link.

(1) Refer to switchgear documentation for use of this information.

(2) Optional MES module.

(3) Optional MES114E or MES114F modules.

Characteristics

Measurement range	20 to 100
Unit	ms
Accuracy	±1 ms typical
Display format	3 significant digits
Resolution	1 ms

Charging time

Operation

This function gives the value of the breaking device ⁽¹⁾ operating mechanism charging time, determined according to the device closed position status change contact and the end of charging contact connected to the Sepam logic inputs ⁽²⁾. The value is saved in the event of an auxiliary power failure.

Readout

The measurement may be accessed via:

- the advanced UMI display unit by pressing the  key
- the display of a PC with the SFT2841 software
- the communication link.

(1) Refer to switchgear documentation for use of this information.

(2) Optional MES114 or MES114E or MES114F modules.

Characteristics

Measurement range	1 to 20
Unit	s
Accuracy	±0.5 sec
Display format	3 significant digits
Resolution	1s

Operation

The VT (Voltage Transformer) supervision function is used to supervise the complete phase and residual voltage measurement chain:

- voltage transformers
- VT connection to Sepam
- Sepam voltage analog inputs.

The function processes the following failures:

- partial loss of phase voltages, detected by:
 - presence of negative sequence voltage
 - and absence of negative sequence current
- loss of all phase voltages, detected by:
 - presence of current on one of the three phases
 - and absence of all measured voltages
- tripping of the phase VT (and/or residual VT) protection relay, detected by the acquisition on a logic input of the fuse melting contact or auxiliary contact of the circuit breaker protecting the VTs
- other types of failures may be processed using the logic equation editor.

The "Phase voltage fault" and "Residual voltage fault" information disappears automatically when the situation returns to normal, i.e. as soon as:

- the cause of the fault has disappeared
- and all of the measured voltages are present.

Use of circuit breaker closed information

The "circuit breaker closed" information is used to detect the loss of one, two or three voltages, if it is connected to a logic input.

If the "circuit breaker closed" information is not connected to a logic input, the detection of VT faults due to the loss of one, two or three voltages is not determined by the position of the circuit breaker.

Block diagram

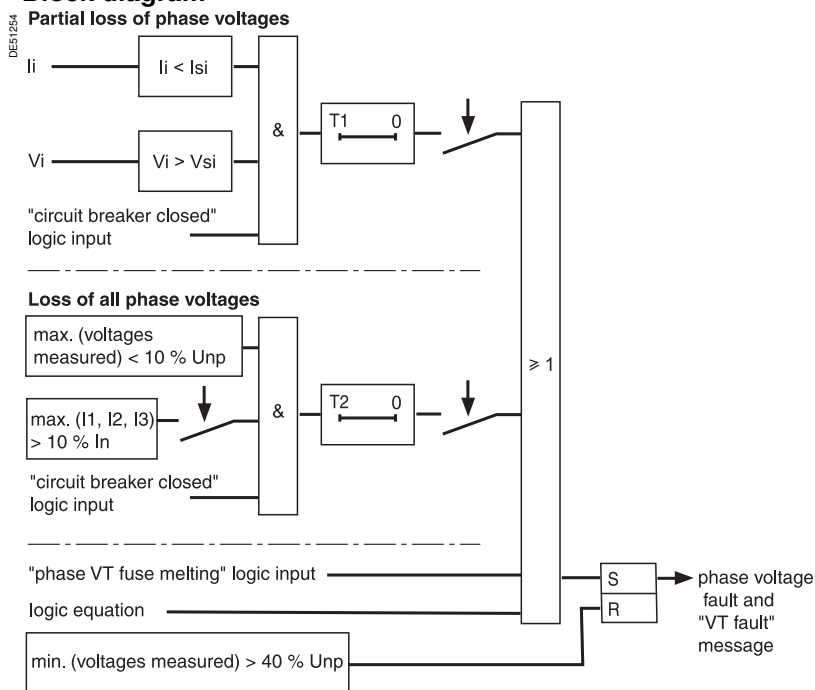

Detection of phase voltage fault.

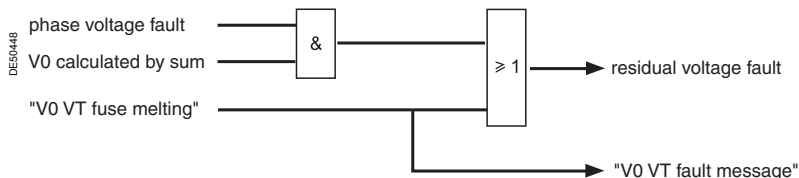

Detection of residual voltage fault.

Consequences of a VT fault on protection functions

A "Phase voltage fault" affects the following protection functions:

- 27/27S, 27D, 32P, 32Q/40, 47, 51V
- 59, only in cases where the protection function is set up for phase-to-neutral overvoltage, when the voltages are measured by two phase VTs + V0 VT
- 67

A "residual voltage fault" affects the following protection functions:

- 59N
- 67N/67NC.

The behavior of the protection functions in the event of a "Phase voltage fault" or "Residual voltage fault" is to be set up and the following choices are proposed:

- for protection functions 27/27S, 27D, 32P, 32Q/40, 47, 51V, 59 and 59N: inhibition or no inhibition
- for protection function 67: inhibition or non-directional operation (50/51)
- for protection function 67N/67NC: inhibition or non-directional operation (50N/51N).

Setting advice

The partial loss of voltages is based on the detection of the presence of negative sequence voltage and the absence of negative sequence current.

By default:

- the presence of negative sequence voltage is detected when: $V_i > 10 \% V_{np}$ (V_{si})
- the absence of negative sequence current is detected when: $I_i < 5 \% I_n$ (I_{si})
- time delay T1 is 1 s.

These default settings ensure the stability of the VT supervision function in the event of short-circuits or transient phenomena on the network.

The I_{si} set point may be raised for highly unbalanced networks.

Time delay T2 for the detection of the loss of all voltages must be longer than the time it takes for a short-circuit to be cleared by the protection function 50/51 or 67, to avoid the detection of a VT loss of voltage fault triggered by a 3-phase short-circuit.

The time delay for the 51V protection function must be longer than the T1 and T2 time delays used for the detection of voltage losses.

Characteristics

Validation of the detection of partial loss of phase voltages	
Setting	Yes / No
Vsi set point	
Setting	2 % to 100 % of Vnp
Accuracy	±2 % for $V_i \geq 10 \% V_{np}$ ±5 % for $V_i < 10 \% V_{np}$
Resolution	1 %
Pick-up / drop-out ratio	(95 ±2.5) % for $V_i \geq 10 \% V_{np}$
Isi set point	
Setting	5 % to 100 % of In
Accuracy	±5 %
Resolution	1 %
Pick-up / drop-out ratio	(105 ±2.5) %
Time delay T1 (partial loss of phase voltages)	
Setting	0.1 s to 300 s
Accuracy	±2 % or ±25 ms
Resolution	10 ms
Validation of the detection of the loss of all phase voltages	
Setting	Yes / No
Detection of the loss of all voltages with verification of the presence of current	
Setting	Yes / No
Time delay T2 (loss of all voltages)	
Setting	0.1 s to 300 s
Accuracy	±2 % or ±25 ms
Resolution	10 ms
Voltage and power protection behavior	
Setting	No action / inhibition
Protection 67 behavior	
Setting	Non-directional / inhibition
Protection 67N/67NC behavior	
Setting	Non-directional / inhibition

Operation

The CT (Current Transformer) supervision function is used to supervise the complete phase current measurement chain:

- phase current sensors (1 A/5 A CTs or LPCTs)
- phase current sensor connection to Sepam
- Sepam phase current analog inputs.

The function detects the loss of a phase current, when the three phase currents are measured.

The function is inactive if only 2 phase current sensors are connected.

The "CT fault" information disappears automatically when the situation returns to normal, i.e. as soon as the three phase currents are measured and have values greater than 10 % of I_n .

In the event of the loss of a phase current, the following protection functions may be inhibited to avoid nuisance tripping:

- 46, 46BC, 32P and 32Q/40
- 51N if I_0 is calculated by the sum of the phase currents.

Block diagram

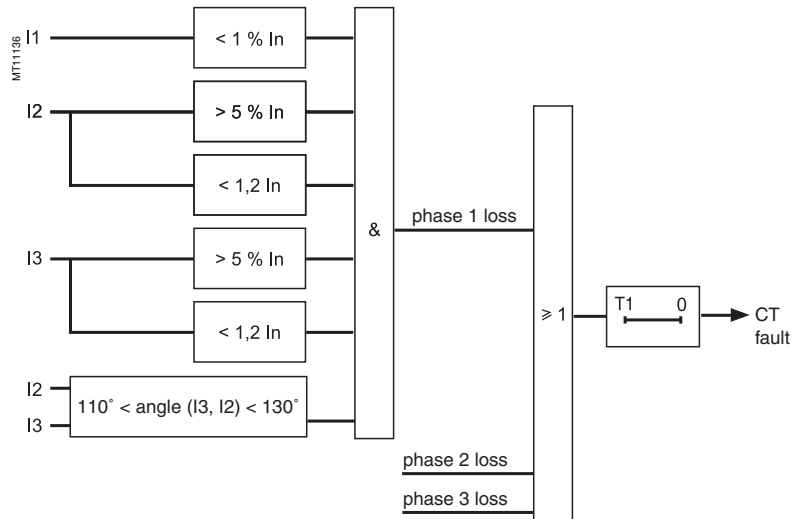

Characteristics

Time delay	
Setting	0.15 s to 300 s
Accuracy	$\pm 2\%$ or ± 25 ms
Resolution	10 ms
Inhibition of protection functions 46, 32P, 32Q/40, 51N	
Setting	No action / inhibition

Setting ranges	48
Undervoltage	51
ANSI code 27/27S	51
Positive sequence undervoltage and phase rotation direction check	52
ANSI code 27D/47	52
Remanent undervoltage	53
ANSI code 27R	53
Directional active overpower	54
ANSI code 32P	54
Directional reactive overpower	55
ANSI code 32Q/40	55
Phase undercurrent	56
ANSI code 37	56
Temperature monitoring	57
ANSI code 38/49T	57
Negative sequence / unbalance	58
ANSI code 46	58
Broken conductor	60
ANSI code 46BC	60
Negative sequence overvoltage	61
ANSI code 47	61
Excessive starting time, locked rotor	62
ANSI code 48/51LR/14	62
Thermal overload	63
ANSI code 49 RMS	63
Phase overcurrent	72
ANSI code 50/51	72
Phase overcurrent Cold Load Pick-Up/Blocking	74
CLPU 50/51	74
Breaker failure	76
ANSI code 50BF	76
Earth fault	78
ANSI code 50N/51N or 50G/51G	78
Earth fault Cold Load Pick-Up/Blocking	80
CLPU 50N/51N	80
Voltage-restrained phase overcurrent	82
ANSI code 50V/51V	82
Overvoltage	84
ANSI code 59	84
Neutral voltage displacement	85
ANSI code 59N	85
Starts per hour	86
ANSI code 66	86
Directional phase overcurrent	87
ANSI code 67	87
Directional earth fault	91
ANSI code 67N/67NC	91
Recloser	99
ANSI code 79	99

Overfrequency	102
ANSI code 81H	
Underfrequency	103
ANSI code 81L	
General	104
Tripping curves	

Functions	Settings	Time delays
ANSI 27 - Phase-to-phase undervoltage		
	5 to 120 % of Unp	0.05 s to 300 s
ANSI 27D/47 - Positive sequence undervoltage		
	5 to 60 % of Unp	0.05 s to 300 s
ANSI 27R - Remanent undervoltage		
	5 to 100 % of Unp	0.05 s to 300 s
ANSI 27S - Phase-to-neutral undervoltage		
	5 to 120 % of Vnp	0.05 s to 300 s
ANSI 32P - Directional active overpower		
	1 to 120 % of Sn ⁽¹⁾	0.1 s to 300 s
ANSI 32Q/40 - Directional reactive overpower		
	5 to 120 % of Sn ⁽¹⁾	0.1 s to 300 s
ANSI 37 - Phase undercurrent		
	0.15 to 1 lb	0.05 s to 300 s
ANSI 38/49T - Temperature monitoring (8 or 16 RTDs)		
Alarm and trip set points	0 to 180 °C (or 32 to 356 °F)	
ANSI 46 - Negative sequence / unbalance		
Definite time	0.1 to 5 lb	0.1 s to 300 s
IDMT	0.1 to 0.5 lb (Schneider Electric) 0.1 to 1 lb (CEI, IEEE)	
Tripping curve	Schneider Electric CEI: SIT/A, LTI/B, VIT/B, EIT/C IEEE: MI (D), VI (E), EI (F)	
ANSI 46BC - Broken Conductor		
Set point Ii/I _d	10 to 100 %	0.1 s to 300 s
ANSI 47 - Negative sequence overvoltage		
	1 to 50 % of Unp	0.05 s to 300 s
ANSI 48/51LR/14 - Excessive starting time, locked rotor		
	0.5 lb to 5 lb	ST starting time 0.5 s to 300 s
		LT and LTS time delays 0.05 s to 300 s
ANSI 49RMS - Thermal overload		
Accounting for negative sequence component	0 - 2.25 - 4.5 - 9	Rate 1 Rate 2
Time constant	Heating	T1: 5 to 120 mn
	Cooling	T2: 5 to 600 mn
Alarm and tripping set points	50 to 300 % of rated thermal capacity	
Cold curve modification factor	0 to 100 %	
Switching of thermal settings conditions	By logic input	
Maximum equipment temperature	By Is set point adjustable from 0.25 to 8 lb 60 to 200 °C	

⁽¹⁾ $S_n = \sqrt{3} \cdot I_n \cdot U_{np}$.

Functions	Settings	Time delays	
ANSI 50/51 - Phase overcurrent			
Tripping curve	Tripping time delay	Timer hold	
	Definite time	DT	
	SIT, LTI, VIT, EIT, UIT ⁽¹⁾	DT	
	RI	DT	
	CEI: SIT/A, LTI/B, VIT/B, EIT/C	DT or IDMT	
	IEEE: MI (D), VI (E), EI (F)	DT or IDMT	
Is set point	IAC: I, VI, EI	DT or IDMT	
	0.1 to 24 In	Definite time	Inst ; 0.05 s to 300 s
Timer hold	0.1 to 2.4 In	IDMT	0.1 s to 12.5 s at 10 Is
	Definite time (DT ; timer hold)		Inst ; 0.05 s to 300 s
Confirmation	IDMT (IDMT ; reset time)		0.5 s to 20 s
	None		
Harmonic 2 restraint set point	By negative sequence overvoltage		
	By phase-to-phase undervoltage		
Short circuit current Isc min	5 to 50%		
	In to 999 kA		
CLPU 50/51 - Phase Overcurrent Cold Load Pick-Up/Blocking			
Time before activation Tcold			0.1 to 300 s
Pick-up threshold CLPUs	10 to 100% of In		
Global action CLPU 50/51	Blocking or multiplication of the set point		
Action on unit x ANSI 50/51	OFF or ON		
Time delay T/x			100 ms to 999 min
Multiplying factor M/x	100 to 999% of Is		
ANSI 50BF - Breaker failure			
Presence of current	0.2 to 2 In		
Operating time	0.05 s to 300 s		
ANSI 50N/51N or 50G/51G - Earth fault / Sensitive earth fault			
Tripping curve	Tripping time delay	Timer hold	
	Definite time	DT	
	SIT, LTI, VIT, EIT, UIT ⁽¹⁾	DT	
	RI	DT	
	CEI: SIT/A, LTI/B, VIT/B, EIT/C	DT or IDMT	
	IEEE: MI (D), VI (E), EI (F)	DT or IDMT	
Is0 set point	IAC: I, VI, EI	DT or IDMT	
	0.1 to 15 In0	Definite time	Inst ; 0.05 s to 300 s
Timer hold	0.1 to 1 In0	IDMT	0.1 s to 12.5 s at 10 Is0
	Definite time (DT ; timer hold)		Inst ; 0.05 s to 300 s
Confirmation	IDMT (IDMT ; reset time)		0.5 s to 20 s
CLPU 50N/51N - Earth Fault Cold Load Pick-Up/Blocking			
Time before activation Tcold			0.1 to 300 s
Pick-up threshold CLPUs	10 to 100% of In0		
Global action CLPU 50N/51N	Blocking or multiplication of the set point		
Action on unit x ANSI 50N/51N	OFF or ON		
Time delay T0/x			100 ms to 999 min
Multiplying factor M0/x	100 to 999% of Is0		
ANSI 50V/51V - Voltage-restrained overcurrent			
Tripping curve	Tripping time delay	Timer hold	
	Definite time	DT	
	SIT, LTI, VIT, EIT, UIT ⁽¹⁾	DT	
	RI	DT	
	CEI: SIT/A, LTI/B, VIT/B, EIT/C	DT or IDMT	
	IEEE: MI (D), VI (E), EI (F)	DT or IDMT	
Is set point	IAC: I, VI, EI	DT or IDMT	
	0.5 to 24 In	Definite time	Inst ; 0.05 s to 300 s
Timer hold	0.5 to 2,4 In	IDMT	0.1 s to 12.5 s at 10 Is
	Definite time (DT ; timer hold)		Inst ; 0.05 s to 300 s
Confirmation	IDMT (IDMT ; reset time)		0.5 s to 20 s

(1) Tripping as of 1.2 Is.

Functions	Settings	Time delays
ANSI 59 - Overvoltage (L-L or L-N)		
	50 to 150% of Unp (or Vnp) if Uns < 208 V	0.05 to 300 s
	50 to 135% of Unp (or Vnp) if Uns ≥ 208 V	0.05 to 300 s
ANSI 59N - Neutral voltage displacement		
	2 to 80 % of Unp	0.05 s to 300 s
ANSI 66 - Starts per hour		
Starts per period	1 to 60	Period
Consecutive starts	1 to 60	Time between starts
		1 to 6 hr
		0 to 90 mn
ANSI 67 - Directional phase overcurrent		
Tripping curve	Tripping time delay	Timer hold
	Definite time	DT
	SIT, LTI, VIT, EIT, UIT ⁽¹⁾	DT
	RI	DT
	CEI: SIT/A, LTI/B, VIT/B, EIT/C	DT or IDMT
	IEEE: MI (D), VI (E), EI (F)	DT or IDMT
	IAC: I, VI, EI	DT or IDMT
Is set point	0.1 to 24 In	Definite time
	0.1 to 2,4 In	IDMT
Timer hold	Definite time (DT ; timer hold)	Inst ; 0.05 s to 300 s
	IDMT (IDMT ; reset time)	0.1 s to 12.5 s at 10 Is 0.5 s to 20 s
Characteristic angle	30°, 45°, 60°	
ANSI 67N/67NC type 1 - Directional earth fault, according to I0 projection		
Characteristic angle	-45°, 0°, 15°, 30°, 45°, 60°, 90°	
Is0 set point	0.1 to 15 In0	Definite time
Vs0 set point	2 to 80 % of Un	
Memory time	T0mem time	0 ; 0.05 s to 300 s
	V0mem validity set point	0 ; 2 to 80 % of Unp
ANSI 67N/67NC type 2 - Directional earth fault, according to I0 magnitude with half-plan tripping zone		
Characteristic angle	-45°, 0°, 15°, 30°, 45°, 60°, 90°	
Tripping curve	Tripping time delay	Timer hold
	Definite time	DT
	SIT, LTI, VIT, EIT, UIT ⁽¹⁾	DT
	RI	DT
	CEI: SIT/A, LTI/B, VIT/B, EIT/C	DT or IDMT
	IEEE: MI (D), VI (E), EI (F)	DT or IDMT
	IAC: I, VI, EI	DT or IDMT
Is0 set point	0.1 to 15 In0	Definite time
	0.1 to 1 In0	IDMT
Vs0 set point	2 to 80 % of Unp	
Timer hold	Definite time (DT ; timer hold)	Inst ; 0.05 s to 300 s
	IDMT (IDMT ; reset time)	0.1 s to 12.5 s at 10 Is0 0.5 s to 20 s
ANSI 67N/67NC type 3 - Directional earth fault, according to I0 magnitude with angular sector tripping zone		
Angle at start of tripping zone	0° to 359°	
Angle at end of tripping zone	0° to 359°	
Is0 set point	CSH core balance CT	2 A rating: 0.1 A to 30 A
		20 A rating: 2 A to 300 A
	1 A CT (sensitive, In0 = 0.1 CT In)	Definite time
Core balance CT + ACE990 (range 1)	0.05 to 15 In0 (min. 0.1 A)	Definite time
	0.05 to 15 In0 (min. 0.1 A)	Inst ; 0.05 to 300 s
Vs0 set point	Calculated V0 (sum of 3 voltages)	2 to 80 % of Unp
	Measured V0 (external VT)	0.6 to 80 % of Unp
ANSI 81H - Overfrequency		
	50 to 55 Hz or 60 to 65 Hz	0.1 s to 300 s
ANSI 81L - Underfrequency		
	40 to 50 Hz or 50 to 60 Hz	0.1 s to 300 s

(1) Tripping as of 1.2 Is.

Operation

The protection function is three-phase and operates according to parameter setting with phase-to-neutral or phase-to-phase voltage:

- it picks up if one of the 3 phase-to-neutral or phase-to-phase voltages drops below the U_s (or V_s) set point
- it includes a definite time delay T
- with phase-to-neutral operation, it indicates the faulty phase in the alarm associated with the fault.

Block diagram

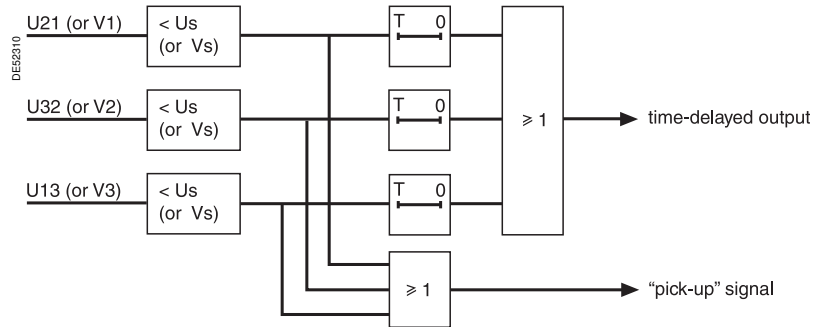

Characteristics

Us (or Vs) set point	
Setting	5 % Unp (or Vnp) to 120 % Unp (or Vnp)
Accuracy ⁽¹⁾	±2 % or ±0.002 Unp
Resolution	1 %
Drop out/pick up ratio	103 % ±2.5 %
Time delay T	
Setting	50 ms to 300 s
Accuracy ⁽¹⁾	±2 %, or ±25 ms
Resolution	10 ms or 1 digit
Characteristic times	
Operation time	pick-up < 35 ms (typically 25 ms)
Overshoot time	< 35 ms
Reset time	< 40 ms

⁽¹⁾ In reference conditions (IEC 60255-6).

Connection conditions					
Type of connection	V1, V2, V3	U21	U21, U32	U21 + V0	U21, U32 + V0
Phase-to-neutral operation	Yes	No	No	No	Yes
Phase-to-phase operation	Yes	on U21 only	Yes	on U21 only	Yes

Positive sequence undervoltage and phase rotation direction check ANSI code 27D/47

Operation

Positive sequence undervoltage

The protection picks up when the positive sequence component V_d of a three-phase voltage system drops below the V_{sd} set point with:

$$\vec{V}_d = (1/3)[\vec{V}_1 + a\vec{V}_2 + a^2\vec{V}_3]$$

$$\vec{V}_d = (1/3)[\vec{U}_{21} - a^2\vec{U}_{32}]$$

with $V = \frac{U}{\sqrt{3}}$ and $a = e^{j\frac{2\pi}{3}}$

- it includes a definite time delay T
- it allows drops in motor electrical torque to be detected.

Phase rotation direction

This protection also allows the phase rotation direction to be detected. The protection considers that the phase rotation direction is inverse when the positive sequence voltage is less than 10 % of U_{np} and when the phase-to-phase voltage is greater than 80 % of U_{np} .

Block diagram

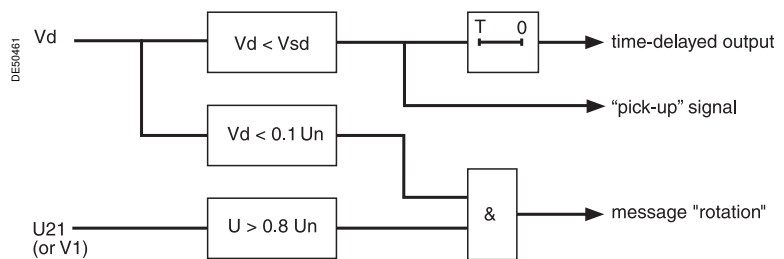

Characteristics

Vsd set point	
Setting	5 % U_{np} to 60 % U_{np}
Accuracy (1)	±2 %
Pick-up/drop-out ratio	103 % ±2.5 %
Resolution	1 %
Time delay	
Setting	50 ms to 300 s
Accuracy (1)	±2 %, or from -25 ms to +35 ms
Resolution	10 ms or 1 digit
Characteristic times	
Operating time	pick up < 55 ms
Overshoot time	< 35 ms
Reset time	< 35 ms

(1) In reference conditions (IEC 60255-6).

Operation

This protection is single-phase:

- it picks up when the U21 phase-to-phase voltage is less than the U_s set point
- the protection includes a definite time delay.
- for the cases of application requiring a closing inhibition through the circuit breaker / contactor control function (ANSI 86), the following logic equation is required:
 $V_INHIBITCLOSE = NOT (P27R_x_3)$

Block diagram

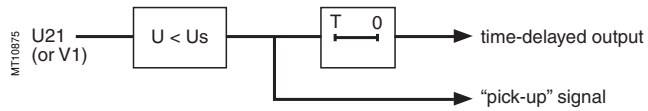

Characteristics

Us set point	
Setting	5 % Unp to 100 % Unp
Accuracy ⁽¹⁾	±5 % or ±0.005 Unp
Resolution	1 %
Drop out/pick up ratio	104 % ±3 %
Time delay T	
Setting	50 ms to 300 s
Accuracy ⁽¹⁾	±2 %, or ±25 ms
Resolution	10 ms or 1 digit
Characteristic times	
Operation time	< 40 ms
Overshoot time	< 20 ms
Reset time	< 30 ms

⁽¹⁾ In reference conditions (IEC 60255-6).

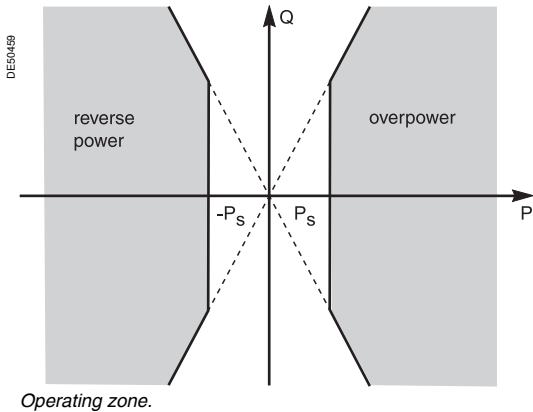

Operation

This function may be used as:

- "active overpower" protection for energy management (load shedding) or
- "reverse active power" protection against motors running like generators and generators running like motors.

It picks up if the active power flowing in one direction or the other (supplied or absorbed) is greater than the P_s set point.

It includes a definite time delay T .

It is based on the two-wattmeter method.

The function is only enabled if the following condition is met:

$P \geq 3.1 \% Q$ which provides a high level of sensitivity and high stability in the event of short-circuits.

The power sign is determined according to the general feeder or incomer parameter, according to the convention:

■ for the feeder circuit:

- power exported by the busbar is positive
- power supplied to the busbar is negative.

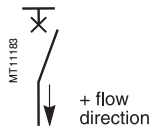

■ for the incomer circuit:

- power supplied to the busbar is positive
- power exported by the busbar is negative

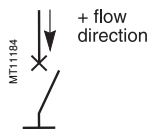

This protection function operates for V1V2V3, U21/U32 and U21/U32 + V0 connections.

Block diagram

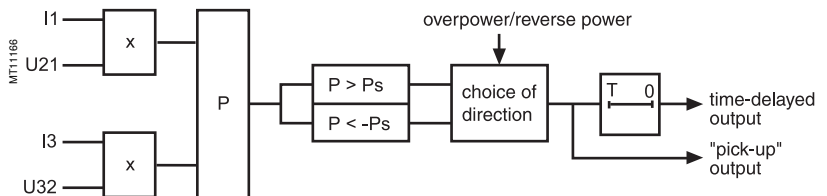

Characteristics

Tripping direction	
Setting	overpower/reverse power
Ps set point	
Setting	1 % $S_n^{(1)}$ to 120 % $S_n^{(1)}$
Resolution	0.1 kW
Accuracy ⁽²⁾	±0.3 % S_n for P_s between 1 % S_n and 5 % S_n ±5 % for P_s between 5 % S_n and 40 % S_n ±3 % for P_s between 40 % S_n and 120 % S_n
Drop out/pick up ratio	(93.5 ±5) %
Min. return variance	0.004 S_n
Time delay T	
Setting	100 ms to 300 s
Resolution	10 ms or 1 digit
Accuracy ⁽²⁾	±2 %, or from -10 ms to +35 ms
Characteristic times	
Operation time	< 80 ms
Overshoot time	< 90 ms
Reset time	< 80 ms

⁽¹⁾ $S_n = \sqrt{3} \cdot Unp \cdot In$.

⁽²⁾ In reference conditions (IEC 60255-6A)

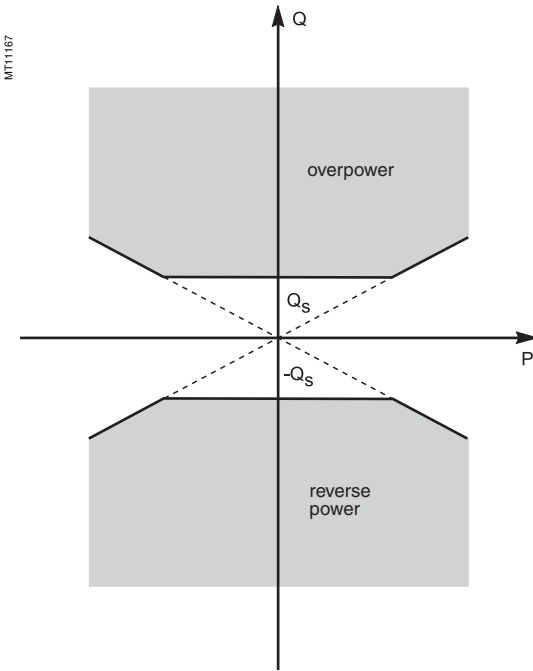

Operating zone.

Operation

This protection function is used to detect field loss on synchronous machines (generators or motors) connected to the network. In both cases, the machine undergoes additional temperature build-up which may damage it. It picks up if the reactive power flowing in one direction or the other (supplied or absorbed) is greater than the Qs set point. It includes a definite time delay T. It is based on the two-wattmeter method. The function is only enabled if the following condition is met: $Q \geq 3.1 \% P$ which provides a high level of sensitivity and high stability in the event of short-circuits.

The power sign is determined according to the general feeder or incomer parameter, according to the convention:

- for the feeder circuit:
 - power exported by the busbar is positive
 - power supplied to the busbar is negative

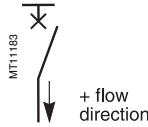

- for the incomer circuit:
 - power supplied to the busbar is positive
 - power exported by the busbar is negative.

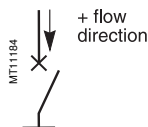

This protection function operates for V1V2V3, U21/U32 and U21/U32 + V0 connections.

To operate with certain synchronous motors, it may be necessary to inhibit the protection function during motor starting. This is done using the "Starting in progress" output of the 48/51LR function in the equation editor.

Block diagram

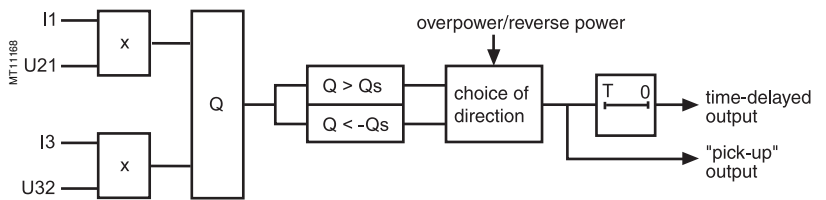

Characteristics

Tripping direction	
Setting	overpower/reverse power
Qs set point	
Setting	5 % Sn ⁽¹⁾ to 120 % Sn ⁽¹⁾
Resolution	0.1 var
Accuracy ⁽²⁾	±5 % for Qs between 5 % Sn and 40 % Sn ±3 % for Qs between 40 % Sn and 120 % Sn
Drop out/pick up ratio	(93.5 ±5) %
Time delay T	
Setting	100 ms to 300 s
Resolution	10 ms or 1 digit
Accuracy ⁽²⁾	±2 %, or from -10 ms to +35 ms
Characteristic times	
Operation time	< 80 ms
Overshoot time	< 90 ms
Reset time	< 80 ms

(1) $S_n = \sqrt{3} \cdot U_{np} \cdot I_n$.

(2) In reference conditions (IEC 60255-6).

Operation

This protection is single-phase:

- it picks up when phase 1 current drops below the I_s set point
- it is inactive when the current is less than 10 % of I_b
- it is insensitive to current drops (breaking) due to circuit breaker tripping
- it includes a definite time delay T .

Tripping of the undercurrent protection may be inhibited by the logic input "Inhibit undercurrent".

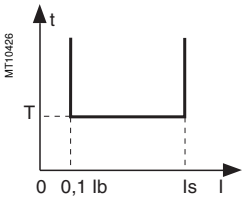

Operating principle

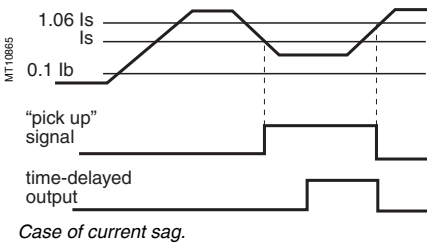

Case of current sag.

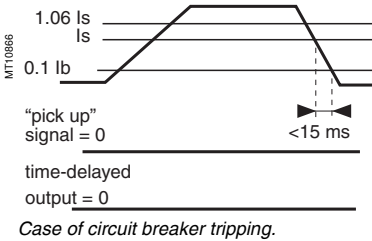

Case of circuit breaker tripping.

Block diagram

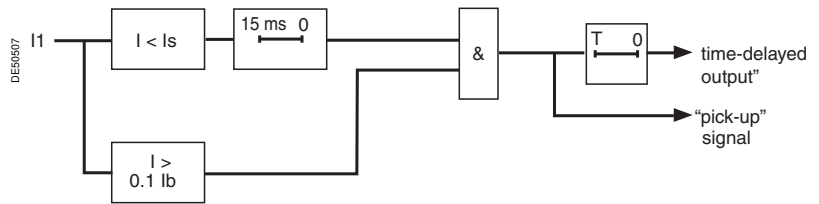

Characteristics

Is set point	
Setting	$15\% I_b \leq I_s \leq 100\% I_b$ by steps of 1 %
Accuracy ⁽¹⁾	$\pm 5\%$
Pick-up/drop-out ratio	$106\% \pm 5\%$ for $I_s > 0.1 I_n$
T time delay	
Setting	$50\text{ ms} \leq T \leq 300\text{ s}$
Accuracy ⁽¹⁾	$\pm 2\%$ or $\pm 25\text{ ms}$
Resolution	10 ms or 1 digit
Characteristic times	
Operation time	$< 60\text{ ms}$
Overshoot time	$< 35\text{ ms}$
Reset time	$< 40\text{ ms}$

(1) In reference conditions (IEC 60255-6).

Operation

This protection is associated with an RTD of the Pt100 platinum (100 Ω at 0 °C or 32 °F) or Ni 100 or Ni 120 nickel type in accordance with the IEC 60751 and DIN 43760 standards.

- it picks up when the monitored temperature is greater than the Ts set point
- it has two independent set points:
 - alarm set point
 - tripping set point
- when the protection is activated, it detects whether the RTD is shorted or disconnected:
 - RTD shorting is detected if the measured temperature is less than -35 °C or -31 °F (measurement displayed "*****")
 - RTD disconnection is detected if the measured temperature is greater than +205 °C or +482 °F (measurement displayed "_*****").

If an RTD fault is detected, the set point output relays are inhibited: the protection outputs are set to zero.

The "RTD fault" item is also made available in the control matrix and an alarm message is generated specifying the faulty RTD module.

Block diagram

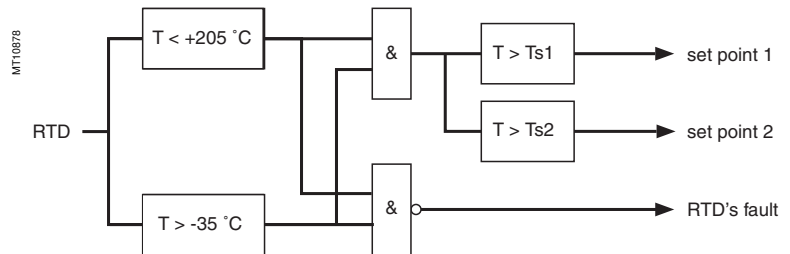

Characteristics

Ts1 and Ts2 set points	°C	°F
Setting	0 °C to 180 °C	32 °F to 356 °F
Accuracy ⁽¹⁾	±1,5 °C	±2,7 °F
Resolution	1 °C	1 °F
Pick-up/drop-out difference	3 °C ±0,5 °	
Characteristic times		
Tripping time	< 5 seconds	

⁽¹⁾ See "connection of MET148-2 module" chapter for accuracy derating according to wiring cross-section.

Standard RTD assignments

The standard assignments described below may be selected when the first MET148□2 module is configured (SFT2841 hardware configuration screen). It is compulsory to choose an assignment in order to use the thermal overload "Cooling time constant calculation" function.

	Motor/generator choice (M40, M41, G40)	Transformer choice (T40, T50, T42, T52)
RTD 1	Stator 1	Phase 1-T1
RTD 2	Stator 2	Phase 1-T2
RTD 3	Stator 3	Phase 2-T1
RTD 4	Bearing 1	Phase 2-T2
RTD 5	Bearing 2	Phase 3-T1
RTD 6	Bearing 3	Phase 3-T2
RTD 7	Bearing 4	
RTD 8	Ambient temperature	Ambient temperature

Operation

The negative sequence / unbalance protection function:

- picks up if the negative sequence component of phase currents is greater than the operation set point
- it is time-delayed. The time delay may be definite time or IDMT according to a standardized curve or specially adapted Schneider curve.

The negative sequence current is determined according to the 3 phase currents.

$$\vec{I}_i = \frac{1}{3} \times (\vec{I}_1 + a^2 \vec{I}_2 + a \vec{I}_3)$$

with $a = e^{j\frac{2\pi}{3}}$

If Sepam is connected to 2 phase current sensors only, the negative sequence current is:

$$|\vec{I}_i| = \frac{1}{\sqrt{3}} \times |\vec{I}_1 - a^2 \vec{I}_3|$$

with $a = e^{j\frac{2\pi}{3}}$

Both formulas are equivalent when there is no zero sequence current (earth fault).

Definite time protection

I_s is the operation set point expressed in Amps, and T is the protection operation time delay.

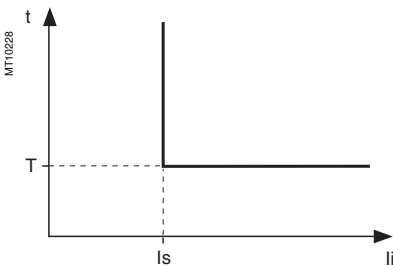

Definite time protection principle.

Standardized IDMT protection

IDMT protection operates in accordance with the IEC 60255-3, BS 142 and IEEE C-37112 standards.

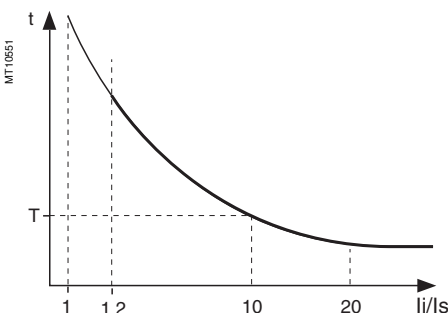

IDMT protection principle.

The I_s setting is the vertical asymptote of the curve and T is the operation time delay for $10 I_s$.

For currents with a very large amplitude, the protection function has a definite time characteristic:

- if $I_i > 20 I_s$, tripping time is the time that corresponds to $20 I_s$
- if $I_i > 40 I_s$, tripping time is the time that corresponds to $40 I_s$.

The following standardized tripping curves are proposed:

- IEC standard inverse time SIT / A
- IEC very inverse time VIT or LTI / B
- IEC extremely inverse time EIT / C
- IEEE moderately inverse (IEC / D)
- IEEE very inverse (IEC / E)
- IEEE extremely inverse (IEC / F)

The curve equations are given in the chapter entitled "IDMT protection functions".

IDMT protection Schneider curve

For $I_i > I_s$, the time delay depends on the value of I_i/I_b (I_b : basis current of the protected equipment defined when the general parameters are set).

T corresponds to the time delay for $I_i/I_b = 5$

The tripping curve is defined according to the following equations:

- for $I_s/I_b \leq I_i/I_b \leq 0.5$

$$t = \frac{3.19}{(I_i/I_b)^{1.5}} \cdot T$$

- for $0.5 \leq I_i/I_b \leq 5$

$$t = \frac{4.64}{(I_i/I_b)^{0.96}} \cdot T$$

- for $I_i/I_b > 5$

$$t = T$$

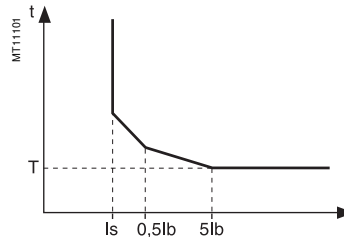

Schneider curve.

Block diagram

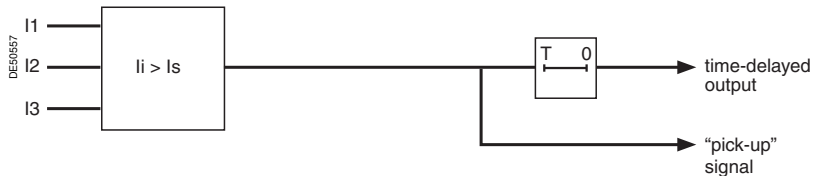

Characteristics

Curve		
Setting	Definite, standardized IDMT (a choice of 6), Schneider IDMT	
Is set point		
Setting	Definite time	10 % $I_b \leq I_s \leq 500$ % I_b
	Standardized IDMT (IEC, IEEE)	10 % $I_b \leq I_s \leq 100$ % I_b
	Schneider IDMT	10 % $I_b \leq I_s \leq 50$ % I_b
Resolution	1 %	
Accuracy (1)	±5 %	
Time delay T		
Setting	Definite time	100 ms ≤ T ≤ 300 s
	IDMT	100 ms ≤ T ≤ 1 s
Resolution	10 ms or 1 digit	
Accuracy (1)	Definite time	±2 % or ±25 ms
	IDMT	±5 % or ±35 ms
Characteristic times		
Operation time	pick-up < 55 ms	
Overshoot time	< 35 ms	
Reset time	< 55 ms	

(1) In reference conditions (IEC 60255-6).

Determination of tripping time for different negative sequence current values for a given Schneider curve

Use the table to find the value of K that corresponds to the required negative sequence current. The tripping time is equal to KT.

Example

given a tripping curve with the setting $T = 0.5$ s.

What is the tripping time at 0.6 Ib?

Use the table to find the value of K that corresponds to 60 % of Ib.

The table reads $K = 7.55$. The tripping time is equal to: $0.5 \times 7.55 = 3.755$ s.

IDMT tripping Schneider curve

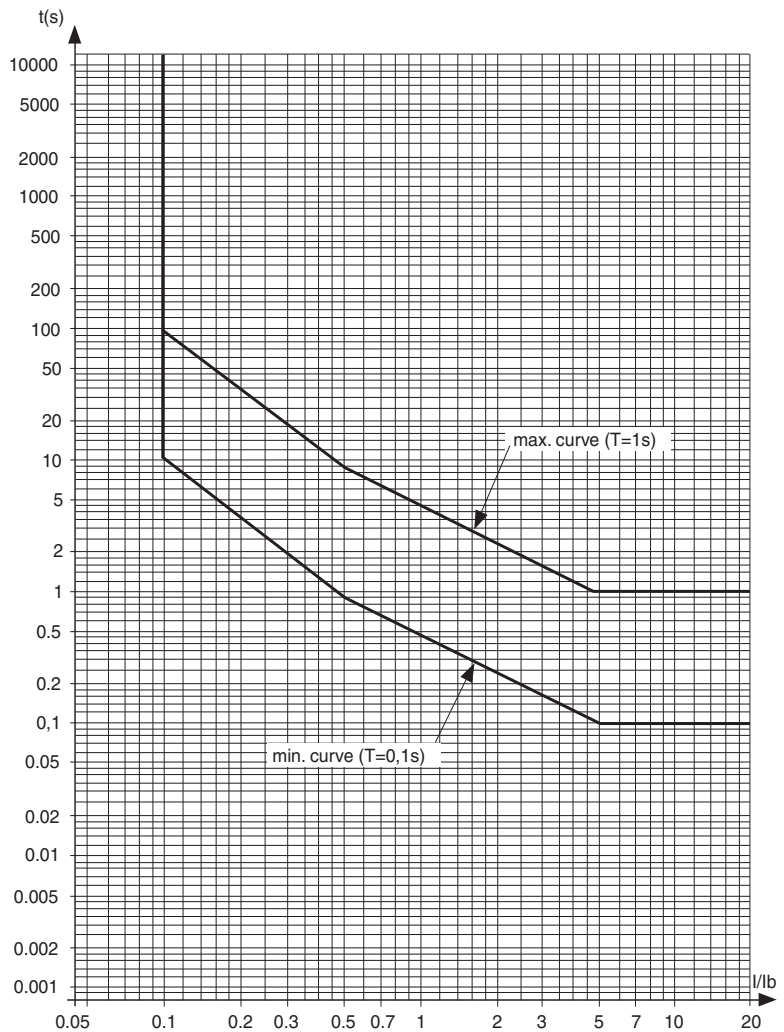

Ii (% Ib)	10	15	20	25	30	33.33	35	40	45	50	55	57.7	60	65	70	75
K	99.95	54.50	35.44	25.38	19.32	16.51	15.34	12.56	10.53	9.00	8.21	7.84	7.55	7.00	6.52	6.11
Ii (% Ib) cont'd	80	85	90	95	100	110	120	130	140	150	160	170	180	190	200	210
K cont'd	5.74	5.42	5.13	4.87	4.64	4.24	3.90	3.61	3.37	3.15	2.96	2.80	2.65	2.52	2.40	2.29
Ii (% Ib) cont'd	22.	230	240	250	260	270	280	290	300	310	320	330	340	350	360	370
K cont'd	2.14	2.10	2.01	1.94	1.86	1.80	1.74	1.68	1.627	1.577	1.53	1.485	1.444	1.404	1.367	1.332
Ii (% Ib) cont'd	380	390	400	410	420	430	440	450	460	470	480	490	≥ 500			
K cont'd	1.298	1.267	1.236	1.18	1.167	1.154	1.13	1.105	1.082	1.06	1.04	1.02	1			

Description

The purpose of Broken conductor detection protection is to indicate, on a radial medium-voltage network, the opening of a phase at a point on the circuit.

This may have several origins:

- broken conductor on the ground at the source end
- broken conductor on the ground at the load end
- open wire without conductor on the ground due to:
 - a broken conductor
 - a blown fuse
 - a problem with a circuit breaker phase.

Operation

Broken conductor detection protection is based on the negative sequence and positive sequence current ratio, which makes it independent of the load fluctuations on the network.

However, these performances depend on:

- the installation:
 - the transformer neutral earthing system
 - capacitive current
 - presence of a permanent negative sequence
- the nature of the fault:
 - broken conductor with either 1 end on the ground at the source end, or 1 end on the ground at the load end, or no end touching the ground
 - distance between the protection relay and the location of the break
 - fault impedance. The impedance depends mainly on the nature of the ground where the fault occurred.

This protection function needs to be wired to 3 phase CTs in working order. If the wiring is with 2 phase CTs or if the CT supervision function has detected a problem, the protection function is automatically inhibited.

By default, the protection is off.

Block diagram

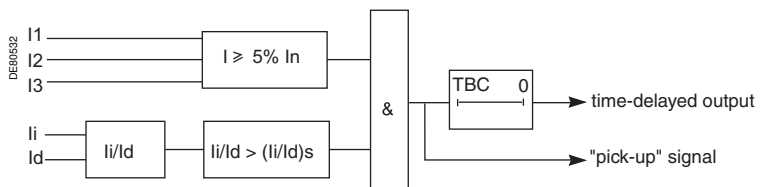

Protection setting assistance

Setting the set point (Ii/Id)s

The further away or more impedant the fault to be detected is, the more sensitive the protection setting needs to be, that is to say the lower the set point (Ii/Id)s setting should be.

However, there may be a permanent negative sequence on the network due to the loads connected. In this case, the protection set point must be set higher than this negative sequence.

To set the protection set point, you must:

- read the peak demand negative sequence and positive sequence current ratio value (see page 32) after a time representative of the activity on the installation
- set the set point (Ii/Id)s to a value 30 to 50% higher than the value read on the peak demand meter.

Setting the TBC time delay

A significant negative sequence may appear briefly on the network, for example after a transformer switches downstream, or after a short-circuit. For this reason, it is advisable to choose a TBC time delay of at least 1 second, and in any case longer than that for the other protection functions.

Characteristics

Set point (Ii/Id)s		
Setting		10 to 100%
Resolution		1%
TBC time delay		
Setting	definite time	0.1 to 300 s
Accuracy ⁽¹⁾		±2%, or ±25 ms
Resolution		10 ms or 1 digit

⁽¹⁾ Under reference conditions (IEC 60255-6).

Operation

The protection function picks up if the negative sequence component of the voltages (V_i) is above the set point (V_{si}).

- it includes a definite time delay T
- the negative sequence voltage V_i is determined from the three phase voltages:

$$\vec{V}_i = \frac{1}{3}(\vec{V}_1 + a^2\vec{V}_2 + a\vec{V}_3)$$

or

$$\vec{V}_i = \frac{1}{3}(\vec{U}_{21} - a\vec{U}_{32})$$

with $a = e^{j\frac{2\pi}{3}}$

This protection function only operates with connections V1V2V3, U21/U32 + V0 and U21/U32.

Block diagram

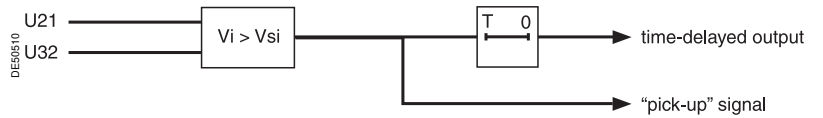

Characteristics

Vsi set point	
Setting	1 % Unp to 50 % Unp
Accuracy ⁽¹⁾	±2 % for $V_i \geq 10\% \text{ Unp}$ ±5 % for $V_i < 10\% \text{ Unp}$
Resolution	1 %
Drop out/pick up ratio	(97 ±2.5) % at $V_i \geq 10\% \text{ Unp}$
Time delay T	
Setting	50 ms to 300 s
Accuracy ⁽¹⁾	±2 %, or ±25 ms
Resolution	10 ms or 1 digit
Characteristic times	
Operation time	pick-up < 55 ms
Overshoot time	< 35 ms
Reset time	< 55 ms

⁽¹⁾ In reference conditions (IEC 60255-6).

Excessive starting time, locked rotor ANSI code 48/51LR/14

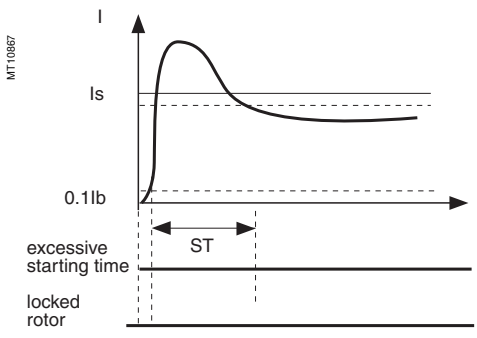

Case of normal starting.

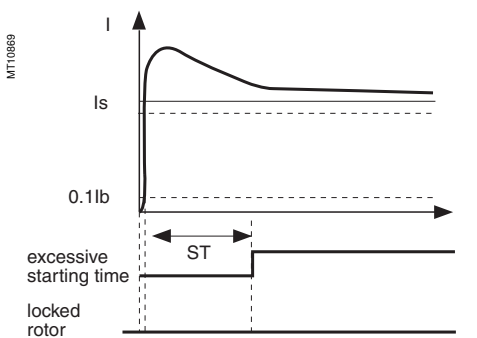

Case of excessive starting time.

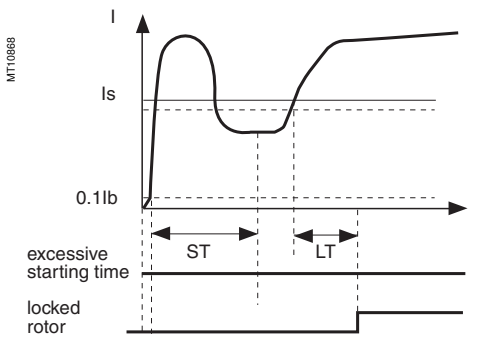

Case of locked rotor.

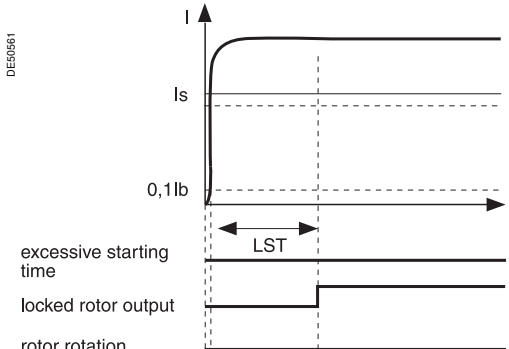

Case of starting locked rotor.

Operation

This function is three-phase. It comprises two parts:

- excessive starting time: during starting, the protection picks up when one of the 3 phase currents is greater than the set point I_s for a longer period of time than the ST time delay (normal starting time)
- locked rotor:
 - at the normal operating rate (after starting), the protection picks up when one of the 3 phase currents is greater than the set point I_s for a longer period of time than the LT time delay of the definite time type.
 - locked on start: large motors may have very long starting time, due to their inertia or the reduce voltage supply. This starting time is longer than the permissive rotor blocking time. To protect such a motor LTS timer initiate a trip if a start has been detected ($I > I_s$) or if the motor speed is zero. For a normal start, the input I23 (zero-speed-switch) disable this protection.

Motor re-acceleration

When the motor re-accelerates, it consumes a current in the vicinity of the starting current ($> I_s$) without the current first passing through a value less than 10 % of I_b . The ST time delay, which corresponds to the normal starting time, may be reinitialized by the logic input "motor re-acceleration" which:

- reinitialize the **excessive starting time** protection,
- set the **locked rotor** protection LT time delay to a low value.

Starting is detected when the current consumed is 10 % greater than the I_b current. An output is set when starting is in progress, to be used in the equation editor.

Block diagram

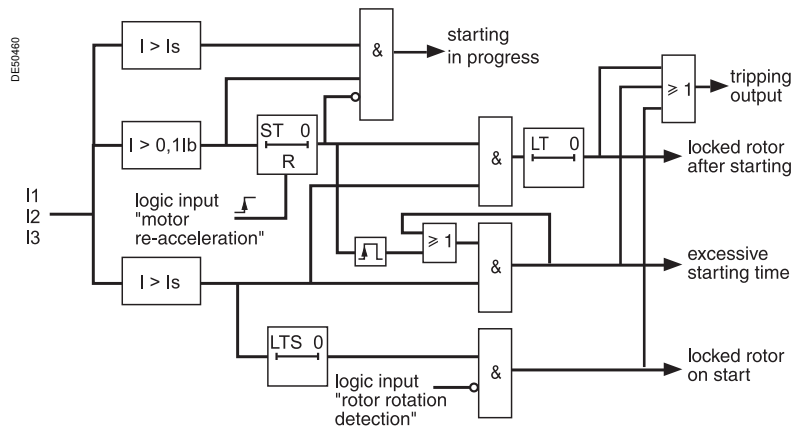

Characteristics

Is set point		
Setting	50 % $I_b \leq I_s \leq 500 \% I_b$	
Resolution	1 %	
Accuracy (1)	±5 %	
Drop out/pick up ratio	93.5 % ±5 %	
Time delay ST, LT and LTS		
Setting	ST	500 ms ≤ T ≤ 300 s
	LT	50 ms ≤ T ≤ 300 s
	LTS	50 ms ≤ T ≤ 300 s
Resolution	10 ms or 1 digit	
Accuracy (1)	±2 % or from -25 ms to +40 ms	

(1) In reference conditions (IEC 60255-6).

Description

This function is used to protect equipment (motors, transformers, generators, lines, capacitors) against overloads, based on measurement of the current consumed.

Operation curve

The protection gives a trip order when the heat rise E, calculated according to the measurement of an equivalent current I_{eq} , is greater than the set point E_s . The greatest permissible continuous current is $I = I_b \sqrt{E_s}$

The protection tripping time is set by the time constant T.

- the calculated heat rise depends on the current consumed and the previous heat rise state
- the cold curve defines the protection tripping time based on zero heat rise
- the hot curve defines the protection tripping time based on 100 % nominal heat rise.

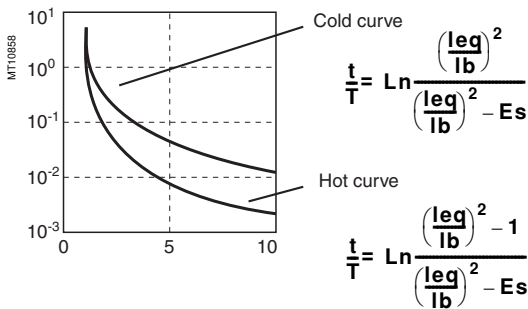

Alarm set point, tripping set point

Two set points may be set for heat rise:

- Es1: alarm.
- Es2: tripping.

"Hot state" set point

When the function is used to protect a motor, this fixed set point is designed for detection of the hot state used by the number of starts function.

The value of the fixed set point is 50 %.

Heat rise and cooling time constants

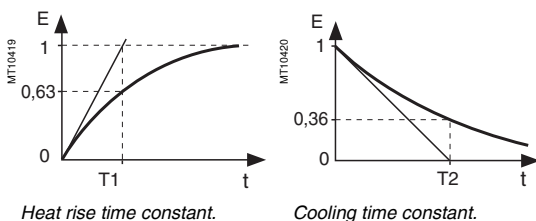

For self-ventilated rotating machines, cooling is more effective when the machine is running than when it is stopped. Running and stopping of the equipment are calculated from the value of the current:

- running if $I > 0.1 I_b$
- stopped if $I < 0.1 I_b$.

Two time constants may be set:

- T1: heat rise time constant: concerns equipment that is running
- T2: cooling time constant: concerns equipment that is stopped.

Accounting for harmonics

The current measured by the thermal protection is an RMS 3-phase current which takes into account harmonics up to number 17.

Accounting for ambient temperature

Most machines are designed to operate at a maximum ambient temperature of 40 °C (104 °F). The thermal overload function takes into account the ambient temperature (Sepam equipped with the temperature sensor module option, with sensor no. 8 assigned to measurement of ambient temperature) to increase the calculated heat rise value when the temperature measured exceeds 40 °C (104 °F).

Increase factor: $f_a = \frac{T_{max} - 40^\circ C}{T_{max} - T_{ambient}}$

in which T_{max} is the equipment's maximum temperature (according to insulation class).

$T_{ambient}$ is the measured temperature.

Adaptation of the protection to motor thermal withstand

Motor thermal protection is often set based on the hot and cold curves supplied by the machine manufacturer. To fully comply with these experimental curves, additional parameters must be set:

- initial heat rise, E_{s0} , is used to reduce the cold tripping time.

modified cold curve:
$$\frac{t}{T} = \text{Ln} \frac{\left(\frac{I_{eq}}{I_b}\right)^2 - E_{s0}}{\left(\frac{I_{eq}}{I_b}\right)^2 - E_s}$$

- a second group of parameters (time constants and set points) is used to take into account thermal withstand with locked rotors. This second set of parameters is taken into account when the current is greater than an adjustable set point I_s .

Accounting for negative sequence current

In the case of motors with coiled rotors, the presence of a negative sequence component increases the heat rise in the motor. The negative sequence component of the current is taken into account in the protection by the equation:

$$I_{eq} = \sqrt{I_{ph}^2 + K \cdot I_i^2}$$

in which I_{ph} is the greatest phase current

I_i is the negative sequence component of the current

K is an adjustable factor

K may have the following values: 0 - 2.25 - 4.5 - 9

For an asynchronous motor, K is determined as follows:

$$K = 2 \cdot \frac{C_d}{C_n} \cdot \frac{1}{g \cdot \left(\frac{I_d}{I_b}\right)^2} - 1$$

in which C_n , C_d : rated torque and starting torque

I_b , I_d : basis current and starting current

g : rated slip.

Learning of the cooling time constant T2

The cooling time constant T_2 may be learnt according to the temperatures measured in the equipment by temperature sensors connected to the MET148-2 module.

T_2 is calculated every time that the equipment runs for a sufficient time, followed by a shutdown ($I < 0.1 I_b$) and temperature stabilization.

For motors and generators, T_2 is calculated according to the temperatures measured on the stator by RTDs 1, 2 and 3.

For transformers, T_2 is calculated according to the temperatures measured on the primary winding by RTDs 1, 3 and 5.

For better accuracy, it is advisable to measure the ambient temperature with RTD 8. If in the RTD assignment table, "other applications" is selected, T_2 is not calculated.

Once the calculation has been made, the calculated value may be used to replace the T_2 (1) parameter in two ways according to the configuration:

- automatically, in which case each new calculated value updates the T_2 constant used
- or manually by entering the value in the T_2 parameter.

(1) It is advisable to use the calculated T_2 if the equipment has carried out at least three starting cycles followed by cooling.

Start inhibit

The thermal overload protection can inhibit the closing of the motor's control device until the heat rise drops back down below a value that allows restarting. This value takes into account the heat rise produced by the motor when starting. The inhibition function is grouped together with the **starts per hour** protection and the indication START INHIBIT informs the user.

Saving of heat rise

The current heat rise is saved in the event of an auxiliary power failure.

Inhibition of tripping

Tripping of the thermal overload protection may be inhibited by the logic input "Inhibit thermal overload" when required by the process.

Use of two operating rates

The thermal overload protection function may be used to protect equipment with two operating rates, for example:

- transformers with two ventilation modes, with or without forced ventilation (ONAN / ONAF)
- two-speed motors.

The protection function comprises two groups of settings, and each group is suitable for equipment protection in one of the two operating rates.

The equipment's basis current, used to calculate heat rise, also depends on the operating rate:

- with rate 1, the basis current I_b , defined as a general Sepam parameter, is used to calculate the heat rise in the equipment
- with rate 2, the basis current I_b -rate 2, a specific thermal overload protection setting, is used to calculate the heat rise in the equipment.

Switching from one group of thermal settings to the other is done without losing the heat rise value. It is controlled:

- either via a logic input, assigned to the "switching of thermal settings" function
- or when the phase current reaches an adjustable I_s set point (to be used to process the switching of thermal settings of a motor with locked rotor).

User information

The following information is available for the user:

- heat rise
 - learnt cooling time constant T2
 - time before restart enabled (in case of inhibition of starting)
 - time before tripping (with constant current).
- See chapter "Machine operation assistance functions", page 37.

Characteristics

Set point	Rate 1	Rate 2	
Setting	Es1 alarm set point	50 % to 300 %	50 % to 300 %
	Es2 tripping set point	50 % to 300%	50 % to 300 %
	Es0 initial heat rise	0 to 100 %	0 to 100 %
Resolution	1 %	1 %	
Time constants			
Setting	T1 running (heat rise)	1 mn to 600 mn	1 mn to 600 mn
	T2 stopped (cooling)	5 mn to 600 mn	5 mn to 600 mn
Resolution	1 mn	1 mn	
Accounting for negative sequence component			
Setting	K	0 - 2.25 - 4.5 - 9	
Maximum equipment temperature (according to insulation class) (2)			
Setting	Tmax 60° à 200°		
Resolution	1°		
Tripping time			
Accuracy (1)	±2 % or 1 s		
RMS current measurement			
Accuracy	±5 %		
Change of operating rate			
By current threshold I_s	Setting	0.25 to 8 I_b	
By logic input "Switching of thermal settings"			
Basis current for thermal operating rate 2			
Setting	0.2 to 2.6 I_n		
Use of learnt cooling time constant (T2)			
Setting	Yes / no		

(1) In reference conditions (IEC 60255-6).

(2) Equipment manufacturer data.

Block diagram

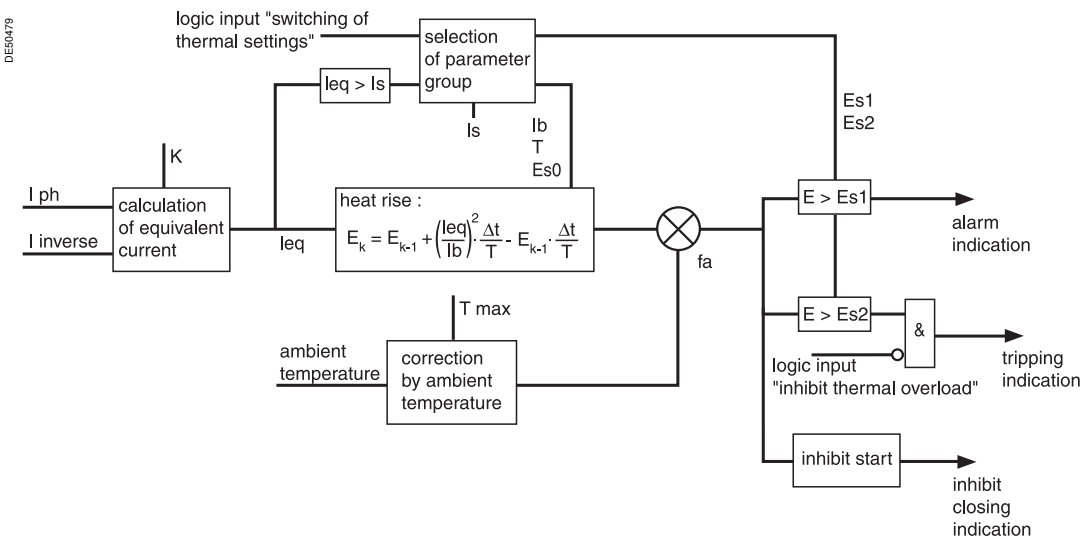

Example 1

The following data are available:

- time constants for on operation T1 and off operation T2:

- T1 = 25 min
- T2 = 70 min

- maximum curve in steady state: $I_{max}/I_b = 1.05$.

Setting of tripping set point Es2

$$Es2 = (I_{max}/I_b)^2 = 110 \%$$

Note: If the motor absorbs a current of 1.05 I_b in steady state, the heat rise calculated by the thermal overload protection will reach 110 %.

Setting of alarm set point Es1

$$Es1 = 90 \% (I/I_b = 0.95).$$

Knegative: 4.5 (usual value)

The other thermal overload parameters do not need to be set. They are not taken into account by default.

Example 2

The following data are available:

- motor thermal resistance in the form of hot and cold curves (see solid line curves in Figure 1)
- cooling time constant T2
- maximum steady state current: $I_{max}/I_b = 1.05$.

Setting of tripping set point Es2

$$Es2 = (I_{max}/I_b)^2 = 110 \%$$

Setting of alarm set point Es1:

$$Es1 = 90 \% (I/I_b = 0.95).$$

The manufacturer's hot/cold curves⁽¹⁾ may be used to determine the heating time constant T1.

The method consists of placing the Sepam hot/cold curves below those of the motor.

For an overload of $2 \cdot I_b$, the value $t/T1 = 0.0339$ ⁽²⁾ is obtained.

In order for Sepam to trip at the point 1 ($t = 70$ s), T1 is equal to 2065 sec \approx 34 min. With a setting of T1 = 34 min, the tripping time is obtained based on a cold state (point 2). In this case, it is equal to $t/T1 = 0.3216 \Rightarrow t \Rightarrow 665$ sec, i.e. \approx 11 min, which is compatible with the thermal resistance of the motor when cold.

The negative sequence factor is calculated using the equation defined on page 63. The parameters of the second thermal overload relay do not need to be set. They are not taken into account by default.

Example 3

The following data are available:

- motor thermal resistance in the form of hot and cold curves (see solid line curves in Figure 1),

- cooling time constant T2

- maximum steady state current: $I_{max}/I_b = 1.1$.

The thermal overload parameters are determined in the same way as in the previous example.

Setting of tripping set point Es2

$$Es2 = (I_{max}/I_b)^2 = 120 \%$$

Setting of alarm set point Es1

$$Es1 = 90 \% (I/I_b = 0.95).$$

The time constant T1 is calculated so that the thermal overload protection trips after 100 s (point 1).

With $t/T1 = 0.069$ ($I/I_b = 2$ and $Es2 = 120 \%$):

$$\Rightarrow T1 = 100s / 0.069 = 1449 \text{ sec} \approx 24 \text{ min.}$$

The tripping time starting from the cold state is equal to:

$$t/T1 = 0.3567 \Rightarrow t = 24 \text{ min} \cdot 0.3567 = 513 \text{ s (point 2')}.$$

This tripping time is too long since the limit for this overload current is 400 s (point 2). If the time constant T1 is lowered, the thermal overload protection will trip earlier, below point 2.

There risk that motor starting when hot will not be possible also exists in this case (see Figure 2 in which a lower Sepam hot curve would intersect the starting curve with $U = 0.9 U_n$).

The **Es0 parameter** is a setting that is used to solve these differences by lowering the Sepam cold curve without moving the hot curve.

In this example, the thermal overload protection should trip after 400 s starting from the cold state.

The following equation is used to obtain the Es0 value:

$$Es0 = \left[\frac{I_{processed}}{I_b} \right]^2 \cdot \frac{t_{necessary}}{e^{T1}} \cdot \left[\left[\frac{I_{processed}}{I_b} \right]^2 - Es2 \right]$$

with:

$t_{necessary}$: tripping time necessary starting from a cold state.

$I_{processed}$: equipment current.

(1) When the machine manufacturer provides both a time constant T1 and the machine hot/cold curves, the use of the curves is recommended since they are more accurate.

(2) The charts containing the numerical values of the Sepam **hot curve** may be used, or else the equation of the curve which is given on page 63.

Figure 1: motor thermal resistance and thermal overload tripping curves

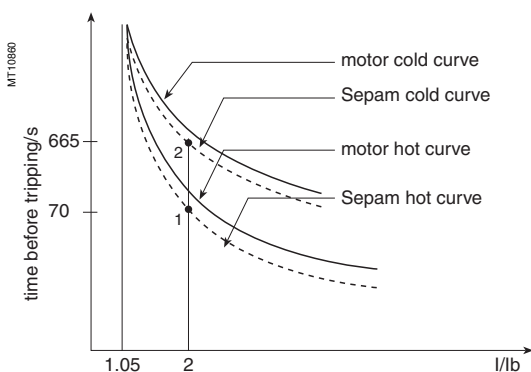

In numerical values, the following is obtained:

$$Es0 = 4 - e^{\frac{400 \text{ sec}}{24 \times 60 \text{ sec}}} [4 - 1.2] = 0.3035 \approx 31\%$$

By setting $Es0 = 31\%$, point 2' is moved downward to obtain a shorter tripping time that is compatible with the motor's thermal resistance when cold (see Figure 3).

Note: A setting $Es0 = 100\%$ therefore means that the hot and cold curves are the same.

Figure 2: hot/cold curves not compatible with the motor's thermal resistance

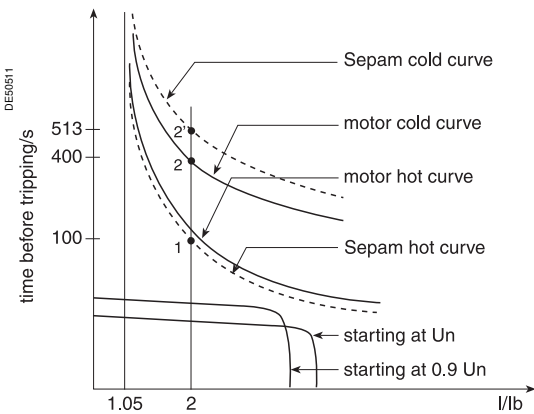
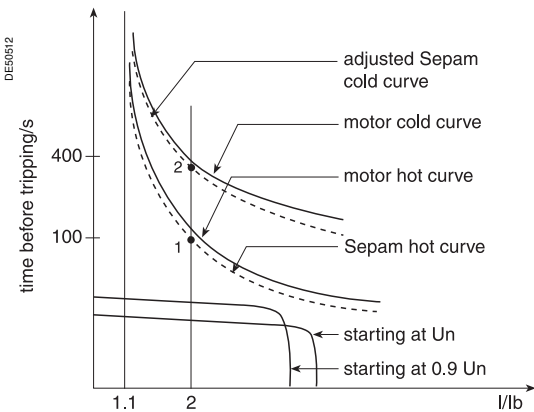

Figure 3: hot/cold curves compatible with the motor's thermal resistance via the setting of an initial heat rise $Es0$



Use of the additional setting group

When a motor rotor is locked or is turning very slowly, its thermal behavior is different from that with the rated load. In such conditions, the motor is damaged by overheating of the rotor or stator. For high power motors, rotor overheating is most often a limiting factor.

The thermal overload parameters chosen for operation with a low overload are no longer valid.

In order to protect the motor in this case, "excessive starting time" protection may be used.

Nevertheless, motor manufacturers provide the thermal resistance curves when the rotor is locked, for different voltages at the time of starting.

Figure 4: Locked rotor thermal resistance

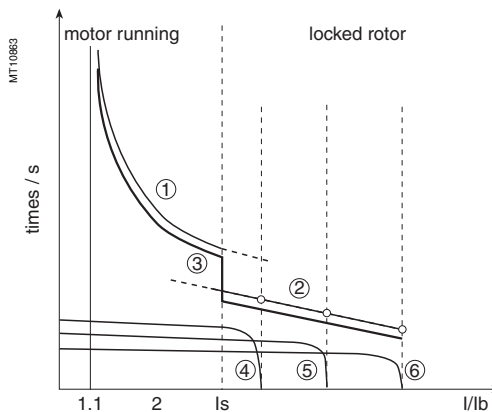

- ①: thermal resistance, motor running
- ②: thermal resistance, motor stopped
- ③: Sepam tripping curve
- ④: starting at 65 % Un
- ⑤: starting at 80 % Un
- ⑥: starting at 100 % Un

In order to take these curves into account, the second thermal overload relay may be used.

The time constant in this case is, in theory, the shortest one: however, it should not be determined in the same way as that of the first relay.

The thermal overload protection switches between the first and second relay if the equivalent current I_{eq} exceeds the I_s value (set point current).

Example 4: transformer with 2 ventilation modes

Given the following data:

The rated current of a transformer with 2 ventilation modes is:

■ $I_b = 200$ A without forced ventilation (ONAN mode), the transformer's main operating rate

■ $I_b = 240$ A with forced ventilation (ONAF mode), a temporary operating rate, to have 20 % more power available

Setting of the basis current for ventilation operating rate 1: $I_b = 200$ A (to be set in Sepam general parameters).

Setting of the basis current for ventilation operating rate 2: $I_b2 = 240$ A (to be set among the specific thermal overload protection settings).

Switching of thermal settings via logic input, to be assigned to the "switching of thermal settings" function and to be connected to the transformer ventilation control unit.

The settings related to each ventilation operating rate (Es set points, time constants, etc.) are to be determined according to the transformer characteristics provided by the manufacturer.

Cold curves for Es0 = 0 %

I/lb	1.00	1.05	1.10	1.15	1.20	1.25	1.30	1.35	1.40	1.45	1.50	1.55	1.60	1.65	1.70	1.75	1.80
50	0.6931	0.6042	0.5331	0.4749	0.4265	0.3857	0.3508	0.3207	0.2945	0.2716	0.2513	0.2333	0.2173	0.2029	0.1900	0.1782	0.1676
55	0.7985	0.6909	0.6061	0.5376	0.4812	0.4339	0.3937	0.3592	0.3294	0.3033	0.2803	0.2600	0.2419	0.2257	0.2111	0.1980	0.1860
60	0.9163	0.7857	0.6849	0.6046	0.5390	0.4845	0.4386	0.3993	0.3655	0.3360	0.3102	0.2873	0.2671	0.2490	0.2327	0.2181	0.2048
65	1.0498	0.8905	0.7704	0.6763	0.6004	0.5379	0.4855	0.4411	0.4029	0.3698	0.3409	0.3155	0.2929	0.2728	0.2548	0.2386	0.2239
70	1.2040	1.0076	0.8640	0.7535	0.6657	0.5942	0.5348	0.4847	0.4418	0.4049	0.3727	0.3444	0.3194	0.2972	0.2774	0.2595	0.2434
75	1.3863	1.1403	0.9671	0.8373	0.7357	0.6539	0.5866	0.5302	0.4823	0.4412	0.4055	0.3742	0.3467	0.3222	0.3005	0.2809	0.2633
80	1.6094	1.2933	1.0822	0.9287	0.8109	0.7174	0.6413	0.5780	0.5245	0.4788	0.4394	0.4049	0.3747	0.3479	0.3241	0.3028	0.2836
85	1.8971	1.4739	1.2123	1.0292	0.8923	0.7853	0.6991	0.6281	0.5686	0.5180	0.4745	0.4366	0.4035	0.3743	0.3483	0.3251	0.3043
90	2.3026	1.6946	1.3618	1.1411	0.9808	0.8580	0.7605	0.6809	0.6147	0.5587	0.5108	0.4694	0.4332	0.4013	0.3731	0.3480	0.3254
95		1.9782	1.5377	1.2670	1.0780	0.9365	0.8258	0.7366	0.6630	0.6012	0.5486	0.5032	0.4638	0.4292	0.3986	0.3714	0.3470
100		2.3755	1.7513	1.4112	1.1856	1.0217	0.8958	0.7956	0.7138	0.6455	0.5878	0.5383	0.4953	0.4578	0.4247	0.3953	0.3691
105		3.0445	2.0232	1.5796	1.3063	1.1147	0.9710	0.8583	0.7673	0.6920	0.6286	0.5746	0.5279	0.4872	0.4515	0.4199	0.3917
110			2.3979	1.7824	1.4435	1.2174	1.0524	0.9252	0.8238	0.7406	0.6712	0.6122	0.5616	0.5176	0.4790	0.4450	0.4148
115			3.0040	2.0369	1.6025	1.3318	1.1409	0.9970	0.8837	0.7918	0.7156	0.6514	0.5964	0.5489	0.5074	0.4708	0.4384
120				2.3792	1.7918	1.4610	1.2381	1.0742	0.9474	0.8457	0.7621	0.6921	0.6325	0.5812	0.5365	0.4973	0.4626
125				2.9037	2.0254	1.6094	1.3457	1.1580	1.0154	0.9027	0.8109	0.7346	0.6700	0.6146	0.5666	0.5245	0.4874
130					2.3308	1.7838	1.4663	1.2493	1.0885	0.9632	0.8622	0.7789	0.7089	0.6491	0.5975	0.5525	0.5129
135					2.7726	1.9951	1.6035	1.3499	1.1672	1.0275	0.9163	0.8253	0.7494	0.6849	0.6295	0.5813	0.5390
140						2.2634	1.7626	1.4618	1.2528	1.0962	0.9734	0.8740	0.7916	0.7220	0.6625	0.6109	0.5658
145						2.6311	1.9518	1.5877	1.3463	1.1701	1.0341	0.9252	0.8356	0.7606	0.6966	0.6414	0.5934
150							3.2189	2.1855	1.7319	1.4495	1.2498	1.0986	0.9791	0.8817	0.8007	0.7320	0.6729
155								2.4908	1.9003	1.5645	1.3364	1.1676	1.0361	0.9301	0.8424	0.7686	0.7055
160								2.9327	2.1030	1.6946	1.4313	1.2417	1.0965	0.9808	0.8860	0.8066	0.7391
165									2.3576	1.8441	1.5361	1.3218	1.1609	1.0343	0.9316	0.8461	0.7739
170									2.6999	2.0200	1.6532	1.4088	1.2296	1.0908	0.9793	0.8873	0.8099
175										3.2244	2.2336	1.7858	1.5041	1.3035	1.1507	1.0294	0.9302
180											2.5055	1.9388	1.6094	1.3832	1.2144	1.0822	0.9751
185												2.8802	2.1195	1.7272	1.4698	1.2825	1.1379
190													3.4864	2.3401	1.8608	1.5647	1.3555
195														2.6237	2.0149	1.6695	1.4343
200															3.0210	2.1972	1.7866

Cold curves for Es0 = 0 %

I/lb Es (%)	1.85	1.90	1.95	2.00	2.20	2.40	2.60	2.80	3.00	3.20	3.40	3.60	3.80	4.00	4.20	4.40	4.60
50	0.1579	0.1491	0.1410	0.1335	0.1090	0.0908	0.0768	0.0659	0.0572	0.0501	0.0442	0.0393	0.0352	0.0317	0.0288	0.0262	0.0239
55	0.1752	0.1653	0.1562	0.1479	0.1206	0.1004	0.0849	0.0727	0.0631	0.0552	0.0487	0.0434	0.0388	0.0350	0.0317	0.0288	0.0263
60	0.1927	0.1818	0.1717	0.1625	0.1324	0.1100	0.0929	0.0796	0.069	0.0604	0.0533	0.0474	0.0424	0.0382	0.0346	0.0315	0.0288
65	0.2106	0.1985	0.1875	0.1773	0.1442	0.1197	0.1011	0.0865	0.075	0.0656	0.0579	0.0515	0.0461	0.0415	0.0375	0.0342	0.0312
70	0.2288	0.2156	0.2035	0.1924	0.1562	0.1296	0.1093	0.0935	0.081	0.0708	0.0625	0.0555	0.0497	0.0447	0.0405	0.0368	0.0336
75	0.2474	0.2329	0.2197	0.2076	0.1684	0.1395	0.1176	0.1006	0.087	0.0761	0.0671	0.0596	0.0533	0.0480	0.0434	0.0395	0.0361
80	0.2662	0.2505	0.2362	0.2231	0.1807	0.1495	0.1260	0.1076	0.0931	0.0813	0.0717	0.0637	0.0570	0.0513	0.0464	0.0422	0.0385
85	0.2855	0.2685	0.2530	0.2389	0.1931	0.1597	0.1344	0.1148	0.0992	0.0867	0.0764	0.0678	0.0607	0.0546	0.0494	0.0449	0.0410
90	0.3051	0.2868	0.2701	0.2549	0.2057	0.1699	0.1429	0.1219	0.1054	0.092	0.0811	0.0720	0.0644	0.0579	0.0524	0.0476	0.0435
95	0.3251	0.3054	0.2875	0.2712	0.2185	0.1802	0.1514	0.1292	0.1116	0.0974	0.0858	0.0761	0.0681	0.0612	0.0554	0.0503	0.0459
100	0.3456	0.3244	0.3051	0.2877	0.2314	0.1907	0.1601	0.1365	0.1178	0.1028	0.0905	0.0803	0.0718	0.0645	0.0584	0.0530	0.0484
105	0.3664	0.3437	0.3231	0.3045	0.2445	0.2012	0.1688	0.1438	0.1241	0.1082	0.0952	0.0845	0.0755	0.0679	0.0614	0.0558	0.0509
110	0.3877	0.3634	0.3415	0.3216	0.2578	0.2119	0.1776	0.1512	0.1304	0.1136	0.1000	0.0887	0.0792	0.0712	0.0644	0.0585	0.0534
115	0.4095	0.3835	0.3602	0.3390	0.2713	0.2227	0.1865	0.1586	0.1367	0.1191	0.1048	0.0929	0.0830	0.0746	0.0674	0.0612	0.0559
120	0.4317	0.4041	0.3792	0.3567	0.2849	0.2336	0.1954	0.1661	0.1431	0.1246	0.1096	0.0972	0.0868	0.0780	0.0705	0.0640	0.0584
125	0.4545	0.4250	0.3986	0.3747	0.2988	0.2446	0.2045	0.1737	0.1495	0.1302	0.1144	0.1014	0.0905	0.0813	0.0735	0.0667	0.0609
130	0.4778	0.4465	0.4184	0.3930	0.3128	0.2558	0.2136	0.1813	0.156	0.1358	0.1193	0.1057	0.0943	0.0847	0.0766	0.0695	0.0634
135	0.5016	0.4683	0.4386	0.4117	0.3270	0.2671	0.2228	0.1890	0.1625	0.1414	0.1242	0.1100	0.0982	0.0881	0.0796	0.0723	0.0659
140	0.5260	0.4907	0.4591	0.4308	0.3414	0.2785	0.2321	0.1967	0.1691	0.147	0.1291	0.1143	0.1020	0.0916	0.0827	0.0751	0.0685
145	0.5511	0.5136	0.4802	0.4502	0.3561	0.2900	0.2414	0.2045	0.1757	0.1527	0.1340	0.1187	0.1058	0.0950	0.0858	0.0778	0.0710
150	0.5767	0.5370	0.5017	0.4700	0.3709	0.3017	0.2509	0.2124	0.1823	0.1584	0.1390	0.1230	0.1097	0.0984	0.0889	0.0806	0.0735
155	0.6031	0.5610	0.5236	0.4902	0.3860	0.3135	0.2604	0.2203	0.189	0.1641	0.1440	0.1274	0.1136	0.1019	0.0920	0.0834	0.0761
160	0.6302	0.5856	0.5461	0.5108	0.4013	0.3254	0.2701	0.2283	0.1957	0.1699	0.1490	0.1318	0.1174	0.1054	0.0951	0.0863	0.0786
165	0.6580	0.6108	0.5690	0.5319	0.4169	0.3375	0.2798	0.2363	0.2025	0.1757	0.1540	0.1362	0.1213	0.1088	0.0982	0.0891	0.0812
170	0.6866	0.6366	0.5925	0.5534	0.4327	0.3498	0.2897	0.2444	0.2094	0.1815	0.1591	0.1406	0.1253	0.1123	0.1013	0.0919	0.0838
175	0.7161	0.6631	0.6166	0.5754	0.4487	0.3621	0.2996	0.2526	0.2162	0.1874	0.1641	0.1451	0.1292	0.1158	0.1045	0.0947	0.0863
180	0.7464	0.6904	0.6413	0.5978	0.4651	0.3747	0.3096	0.2608	0.2231	0.1933	0.1693	0.1495	0.1331	0.1193	0.1076	0.0976	0.0889
185	0.7777	0.7184	0.6665	0.6208	0.4816	0.3874	0.3197	0.2691	0.2301	0.1993	0.1744	0.1540	0.1371	0.1229	0.1108	0.1004	0.0915
190	0.8100	0.7472	0.6925	0.6444	0.4985	0.4003	0.3300	0.2775	0.2371	0.2052	0.1796	0.1585	0.1411	0.1264	0.1140	0.1033	0.0941
195	0.8434	0.7769	0.7191	0.6685	0.5157	0.4133	0.3403	0.2860	0.2442	0.2113	0.1847	0.1631	0.1451	0.1300	0.1171	0.1062	0.0967
200	0.8780	0.8075	0.7465	0.6931	0.5331	0.4265	0.3508	0.2945	0.2513	0.2173	0.1900	0.1676	0.1491	0.1335	0.1203	0.1090	0.0993

3

Cold curves for Es0 = 0 %

I/lb	4.80	5.00	5.50	6.00	6.50	7.00	7.50	8.00	8.50	9.00	9.50	10.00	12.50	15.00	17.50	20.00
50	0.0219	0.0202	0.0167	0.0140	0.0119	0.0103	0.0089	0.0078	0.0069	0.0062	0.0056	0.0050	0.0032	0.0022	0.0016	0.0013
55	0.0242	0.0222	0.0183	0.0154	0.0131	0.0113	0.0098	0.0086	0.0076	0.0068	0.0061	0.0055	0.0035	0.0024	0.0018	0.0014
60	0.0264	0.0243	0.0200	0.0168	0.0143	0.0123	0.0107	0.0094	0.0083	0.0074	0.0067	0.0060	0.0038	0.0027	0.0020	0.0015
65	0.0286	0.0263	0.0217	0.0182	0.0155	0.0134	0.0116	0.0102	0.0090	0.0081	0.0072	0.0065	0.0042	0.0029	0.0021	0.0016
70	0.0309	0.0284	0.0234	0.0196	0.0167	0.0144	0.0125	0.0110	0.0097	0.0087	0.0078	0.0070	0.0045	0.0031	0.0023	0.0018
75	0.0331	0.0305	0.0251	0.0211	0.0179	0.0154	0.0134	0.0118	0.0104	0.0093	0.0083	0.0075	0.0048	0.0033	0.0025	0.0019
80	0.0353	0.0325	0.0268	0.0225	0.0191	0.0165	0.0143	0.0126	0.0111	0.0099	0.0089	0.0080	0.0051	0.0036	0.0026	0.0020
85	0.0376	0.0346	0.0285	0.0239	0.0203	0.0175	0.0152	0.0134	0.0118	0.0105	0.0095	0.0085	0.0055	0.0038	0.0028	0.0021
90	0.0398	0.0367	0.0302	0.0253	0.0215	0.0185	0.0161	0.0142	0.0125	0.0112	0.0100	0.0090	0.0058	0.0040	0.0029	0.0023
95	0.0421	0.0387	0.0319	0.0267	0.0227	0.0196	0.0170	0.0150	0.0132	0.0118	0.0106	0.0095	0.0061	0.0042	0.0031	0.0024
100	0.0444	0.0408	0.0336	0.0282	0.0240	0.0206	0.0179	0.0157	0.0139	0.0124	0.0111	0.0101	0.0064	0.0045	0.0033	0.0025
105	0.0466	0.0429	0.0353	0.0296	0.0252	0.0217	0.0188	0.0165	0.0146	0.0130	0.0117	0.0106	0.0067	0.0047	0.0034	0.0026
110	0.0489	0.0450	0.0370	0.0310	0.0264	0.0227	0.0197	0.0173	0.0153	0.0137	0.0123	0.0111	0.0071	0.0049	0.0036	0.0028
115	0.0512	0.0471	0.0388	0.0325	0.0276	0.0237	0.0207	0.0181	0.0160	0.0143	0.0128	0.0116	0.0074	0.0051	0.0038	0.0029
120	0.0535	0.0492	0.0405	0.0339	0.0288	0.0248	0.0216	0.0189	0.0167	0.0149	0.0134	0.0121	0.0077	0.0053	0.0039	0.0030
125	0.0558	0.0513	0.0422	0.0353	0.0300	0.0258	0.0225	0.0197	0.0175	0.0156	0.0139	0.0126	0.0080	0.0056	0.0041	0.0031
130	0.0581	0.0534	0.0439	0.0368	0.0313	0.0269	0.0234	0.0205	0.0182	0.0162	0.0145	0.0131	0.0084	0.0058	0.0043	0.0033
135	0.0604	0.0555	0.0457	0.0382	0.0325	0.0279	0.0243	0.0213	0.0189	0.0168	0.0151	0.0136	0.0087	0.0060	0.0044	0.0034
140	0.0627	0.0576	0.0474	0.0397	0.0337	0.0290	0.0252	0.0221	0.0196	0.0174	0.0156	0.0141	0.0090	0.0062	0.0046	0.0035
145	0.0650	0.0598	0.0491	0.0411	0.0349	0.0300	0.0261	0.0229	0.0203	0.0181	0.0162	0.0146	0.0093	0.0065	0.0047	0.0036
150	0.0673	0.0619	0.0509	0.0426	0.0361	0.0311	0.0270	0.0237	0.0210	0.0187	0.0168	0.0151	0.0096	0.0067	0.0049	0.0038
155	0.0696	0.0640	0.0526	0.0440	0.0374	0.0321	0.0279	0.0245	0.0217	0.0193	0.0173	0.0156	0.0100	0.0069	0.0051	0.0039
160	0.0720	0.0661	0.0543	0.0455	0.0386	0.0332	0.0289	0.0253	0.0224	0.0200	0.0179	0.0161	0.0103	0.0071	0.0052	0.0040
165	0.0743	0.0683	0.0561	0.0469	0.0398	0.0343	0.0298	0.0261	0.0231	0.0206	0.0185	0.0166	0.0106	0.0074	0.0054	0.0041
170	0.0766	0.0704	0.0578	0.0484	0.0411	0.0353	0.0307	0.0269	0.0238	0.0212	0.0190	0.0171	0.0109	0.0076	0.0056	0.0043
175	0.0790	0.0726	0.0596	0.0498	0.0423	0.0364	0.0316	0.0277	0.0245	0.0218	0.0196	0.0177	0.0113	0.0078	0.0057	0.0044
180	0.0813	0.0747	0.0613	0.0513	0.0435	0.0374	0.0325	0.0285	0.0252	0.0225	0.0201	0.0182	0.0116	0.0080	0.0059	0.0045
185	0.0837	0.0769	0.0631	0.0528	0.0448	0.0385	0.0334	0.0293	0.0259	0.0231	0.0207	0.0187	0.0119	0.0083	0.0061	0.0046
190	0.0861	0.0790	0.0649	0.0542	0.0460	0.0395	0.0344	0.0301	0.0266	0.0237	0.0213	0.0192	0.0122	0.0085	0.0062	0.0048
195	0.0884	0.0812	0.0666	0.0557	0.0473	0.0406	0.0353	0.0309	0.0274	0.0244	0.0218	0.0197	0.0126	0.0087	0.0064	0.0049
200	0.0908	0.0834	0.0684	0.0572	0.0485	0.0417	0.0362	0.0317	0.0281	0.0250	0.0224	0.0202	0.0129	0.0089	0.0066	0.0050

Hot curves

I/lb	1.00	1.05	1.10	1.15	1.20	1.25	1.30	1.35	1.40	1.45	1.50	1.55	1.60	1.65	1.70	1.75	1.80
Es (%)																	
105		0.6690	0.2719	0.1685	0.1206	0.0931	0.0752	0.0627	0.0535	0.0464	0.0408	0.0363	0.0326	0.0295	0.0268	0.0245	0.0226
110		3.7136	0.6466	0.3712	0.2578	0.1957	0.1566	0.1296	0.1100	0.0951	0.0834	0.0740	0.0662	0.0598	0.0544	0.0497	0.0457
115			1.2528	0.6257	0.4169	0.3102	0.2451	0.2013	0.1699	0.1462	0.1278	0.1131	0.1011	0.0911	0.0827	0.0755	0.0693
120			3.0445	0.9680	0.6061	0.4394	0.3423	0.2786	0.2336	0.2002	0.1744	0.1539	0.1372	0.1234	0.1118	0.1020	0.0935
125				1.4925	0.8398	0.5878	0.4499	0.3623	0.3017	0.2572	0.2231	0.1963	0.1747	0.1568	0.1419	0.1292	0.1183
130				2.6626	1.1451	0.7621	0.5705	0.4537	0.3747	0.3176	0.2744	0.2407	0.2136	0.1914	0.1728	0.1572	0.1438
135					1.5870	0.9734	0.7077	0.5543	0.4535	0.3819	0.3285	0.2871	0.2541	0.2271	0.2048	0.1860	0.1699
140					2.3979	1.2417	0.8668	0.6662	0.5390	0.4507	0.3857	0.3358	0.2963	0.2643	0.2378	0.2156	0.1967
145						1.6094	1.0561	0.7921	0.6325	0.5245	0.4463	0.3869	0.3403	0.3028	0.2719	0.2461	0.2243
150						2.1972	1.2897	0.9362	0.7357	0.6042	0.5108	0.4408	0.3864	0.3429	0.3073	0.2776	0.2526
155						3.8067	1.5950	1.1047	0.8508	0.6909	0.5798	0.4978	0.4347	0.3846	0.3439	0.3102	0.2817
160							2.0369	1.3074	0.9808	0.7857	0.6539	0.5583	0.4855	0.4282	0.3819	0.3438	0.3118
165							2.8478	1.5620	1.1304	0.8905	0.7340	0.6226	0.5390	0.4738	0.4215	0.3786	0.3427
170								1.9042	1.3063	1.0076	0.8210	0.6914	0.5955	0.5215	0.4626	0.4146	0.3747
175								2.4288	1.5198	1.1403	0.9163	0.7652	0.6554	0.5717	0.5055	0.4520	0.4077
180								3.5988	1.7918	1.2933	1.0217	0.8449	0.7191	0.6244	0.5504	0.4908	0.4418
185									2.1665	1.4739	1.1394	0.9316	0.7872	0.6802	0.5974	0.5312	0.4772
190									2.7726	1.6946	1.2730	1.0264	0.8602	0.7392	0.6466	0.5733	0.5138
195									4.5643	1.9782	1.4271	1.1312	0.9390	0.8019	0.6985	0.6173	0.5518
200										2.3755	1.6094	1.2483	1.0245	0.8688	0.7531	0.6633	0.5914

I/lb	1.85	1.90	1.95	2.00	2.20	2.40	2.60	2.80	3.00	3.20	3.40	3.60	3.80	4.00	4.20	4.40	4.60
Es (%)																	
105	0.0209	0.0193	0.0180	0.0168	0.0131	0.0106	0.0087	0.0073	0.0063	0.0054	0.0047	0.0042	0.0037	0.0033	0.0030	0.0027	0.0025
110	0.0422	0.0391	0.0363	0.0339	0.0264	0.0212	0.0175	0.0147	0.0126	0.0109	0.0095	0.0084	0.0075	0.0067	0.0060	0.0055	0.0050
115	0.0639	0.0592	0.0550	0.0513	0.0398	0.0320	0.0264	0.0222	0.0189	0.0164	0.0143	0.0126	0.0112	0.0101	0.0091	0.0082	0.0075
120	0.0862	0.0797	0.0740	0.0690	0.0535	0.0429	0.0353	0.0297	0.0253	0.0219	0.0191	0.0169	0.0150	0.0134	0.0121	0.0110	0.0100
125	0.1089	0.1007	0.0934	0.0870	0.0673	0.0540	0.0444	0.0372	0.0317	0.0274	0.0240	0.0211	0.0188	0.0168	0.0151	0.0137	0.0125
130	0.1322	0.1221	0.1132	0.1054	0.0813	0.0651	0.0535	0.0449	0.0382	0.0330	0.0288	0.0254	0.0226	0.0202	0.0182	0.0165	0.0150
135	0.1560	0.1440	0.1334	0.1241	0.0956	0.0764	0.0627	0.0525	0.0447	0.0386	0.0337	0.0297	0.0264	0.0236	0.0213	0.0192	0.0175
140	0.1805	0.1664	0.1540	0.1431	0.1100	0.0878	0.0720	0.0603	0.0513	0.0443	0.0386	0.0340	0.0302	0.0270	0.0243	0.0220	0.0200
145	0.2055	0.1892	0.1750	0.1625	0.1246	0.0993	0.0813	0.0681	0.0579	0.0499	0.0435	0.0384	0.0341	0.0305	0.0274	0.0248	0.0226
150	0.2312	0.2127	0.1965	0.1823	0.1395	0.1110	0.0908	0.0759	0.0645	0.0556	0.0485	0.0427	0.0379	0.0339	0.0305	0.0276	0.0251
155	0.2575	0.2366	0.2185	0.2025	0.1546	0.1228	0.1004	0.0838	0.0712	0.0614	0.0535	0.0471	0.0418	0.0374	0.0336	0.0304	0.0277
160	0.2846	0.2612	0.2409	0.2231	0.1699	0.1347	0.1100	0.0918	0.0780	0.0671	0.0585	0.0515	0.0457	0.0408	0.0367	0.0332	0.0302
165	0.3124	0.2864	0.2639	0.2442	0.1855	0.1468	0.1197	0.0999	0.0847	0.0729	0.0635	0.0559	0.0496	0.0443	0.0398	0.0360	0.0328
170	0.3410	0.3122	0.2874	0.2657	0.2012	0.1591	0.1296	0.1080	0.0916	0.0788	0.0686	0.0603	0.0535	0.0478	0.0430	0.0389	0.0353
175	0.3705	0.3388	0.3115	0.2877	0.2173	0.1715	0.1395	0.1161	0.0984	0.0847	0.0737	0.0648	0.0574	0.0513	0.0461	0.0417	0.0379
180	0.4008	0.3660	0.3361	0.3102	0.2336	0.1840	0.1495	0.1244	0.1054	0.0906	0.0788	0.0692	0.0614	0.0548	0.0493	0.0446	0.0405
185	0.4321	0.3940	0.3614	0.3331	0.2502	0.1967	0.1597	0.1327	0.1123	0.0965	0.0839	0.0737	0.0653	0.0583	0.0524	0.0474	0.0431
190	0.4644	0.4229	0.3873	0.3567	0.2671	0.2096	0.1699	0.1411	0.1193	0.1025	0.0891	0.0782	0.0693	0.0619	0.0556	0.0503	0.0457
195	0.4978	0.4525	0.4140	0.3808	0.2842	0.2226	0.1802	0.1495	0.1264	0.1085	0.0943	0.0828	0.0733	0.0654	0.0588	0.0531	0.0483
200	0.5324	0.4831	0.4413	0.4055	0.3017	0.2358	0.1907	0.1581	0.1335	0.1145	0.0995	0.0873	0.0773	0.0690	0.0620	0.0560	0.0509

3

Hot curves

I _{lb}	4.80	5.00	5.50	6.00	6.50	7.00	7.50	8.00	8.50	9.00	9.50	10.00	12.50	15.00	17.50	20.00
Es (%)																
105	0.0023	0.0021	0.0017	0.0014	0.0012	0.0010	0.0009	0.0008	0.0007	0.0006	0.0006	0.0005	0.0003	0.0002	0.0002	0.0001
110	0.0045	0.0042	0.0034	0.0029	0.0024	0.0021	0.0018	0.0016	0.0014	0.0013	0.0011	0.0010	0.0006	0.0004	0.0003	0.0003
115	0.0068	0.0063	0.0051	0.0043	0.0036	0.0031	0.0027	0.0024	0.0021	0.0019	0.0017	0.0015	0.0010	0.0007	0.0005	0.0004
120	0.0091	0.0084	0.0069	0.0057	0.0049	0.0042	0.0036	0.0032	0.0028	0.0025	0.0022	0.0020	0.0013	0.0009	0.0007	0.0005
125	0.0114	0.0105	0.0086	0.0072	0.0061	0.0052	0.0045	0.0040	0.0035	0.0031	0.0028	0.0025	0.0016	0.0011	0.0008	0.0006
130	0.0137	0.0126	0.0103	0.0086	0.0073	0.0063	0.0054	0.0048	0.0042	0.0038	0.0034	0.0030	0.0019	0.0013	0.0010	0.0008
135	0.0160	0.0147	0.0120	0.0101	0.0085	0.0073	0.0064	0.0056	0.0049	0.0044	0.0039	0.0035	0.0023	0.0016	0.0011	0.0009
140	0.0183	0.0168	0.0138	0.0115	0.0097	0.0084	0.0073	0.0064	0.0056	0.0050	0.0045	0.0040	0.0026	0.0018	0.0013	0.0010
145	0.0206	0.0189	0.0155	0.0129	0.0110	0.0094	0.0082	0.0072	0.0063	0.0056	0.0051	0.0046	0.0029	0.0020	0.0015	0.0011
150	0.0229	0.0211	0.0172	0.0144	0.0122	0.0105	0.0091	0.0080	0.0070	0.0063	0.0056	0.0051	0.0032	0.0022	0.0016	0.0013
155	0.0253	0.0232	0.0190	0.0158	0.0134	0.0115	0.0100	0.0088	0.0077	0.0069	0.0062	0.0056	0.0035	0.0025	0.0018	0.0014
160	0.0276	0.0253	0.0207	0.0173	0.0147	0.0126	0.0109	0.0096	0.0085	0.0075	0.0067	0.0061	0.0039	0.0027	0.0020	0.0015
165	0.0299	0.0275	0.0225	0.0187	0.0159	0.0136	0.0118	0.0104	0.0092	0.0082	0.0073	0.0066	0.0042	0.0029	0.0021	0.0016
170	0.0323	0.0296	0.0242	0.0202	0.0171	0.0147	0.0128	0.0112	0.0099	0.0088	0.0079	0.0071	0.0045	0.0031	0.0023	0.0018
175	0.0346	0.0317	0.0260	0.0217	0.0183	0.0157	0.0137	0.0120	0.0106	0.0094	0.0084	0.0076	0.0048	0.0034	0.0025	0.0019
180	0.0370	0.0339	0.0277	0.0231	0.0196	0.0168	0.0146	0.0128	0.0113	0.0101	0.0090	0.0081	0.0052	0.0036	0.0026	0.0020
185	0.0393	0.0361	0.0295	0.0246	0.0208	0.0179	0.0155	0.0136	0.0120	0.0107	0.0096	0.0086	0.0055	0.0038	0.0028	0.0021
190	0.0417	0.0382	0.0313	0.0261	0.0221	0.0189	0.0164	0.0144	0.0127	0.0113	0.0101	0.0091	0.0058	0.0040	0.0030	0.0023
195	0.0441	0.0404	0.0330	0.0275	0.0233	0.0200	0.0173	0.0152	0.0134	0.0119	0.0107	0.0096	0.0061	0.0043	0.0031	0.0024
200	0.0464	0.0426	0.0348	0.0290	0.0245	0.0211	0.0183	0.0160	0.0141	0.0126	0.0113	0.0102	0.0065	0.0045	0.0033	0.0025

Description

The phase overcurrent function comprises 2 groups of four units, called Group A and Group B respectively.
The mode of switching from one group to the other may be determined by parameter setting:

- by remote control (TC3, TC4)
- by logic input I13 (I13 = 0 group A, I13 = 1 group B) or by forcing the use of the group.

Operation

Phase overcurrent protection is three-phase. It picks up if one, two or three of the phase currents reach the operation set point. The alarm connected to the operation of the protection function indicates the faulty phase or phases. It includes a time delay, which is either definite (constant, DT) or IDMT depending on the curves on the facing page.

Confirmation

The phase overcurrent protection function includes a configurable confirmation component. The output is confirmed as follows:

- by phase-to-phase undervoltage protection unit 1
- by negative sequence overvoltage protection
- no confirmation.

The protection incorporates a harmonic 2 restraint set point which can be used to set the protection I_s set point close to the CT rated current, including when a transformer switches. The restraint can be selected by parameter setting. This harmonic 2 restraint is active when the current is less than half the minimum short-circuit current of the network downstream of the protection.

Definite time protection functions

I_s is the operation set point expressed in Amps, and T is the protection operation time delay.

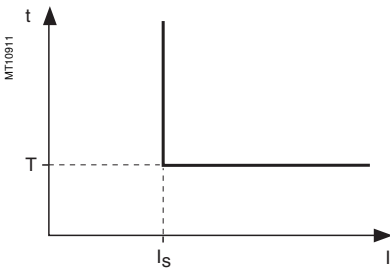

Definite time protection principle.

IDMT protection

IDMT protection operates in accordance with the IEC 60255-3, BS 142, IEEE C-37112 standards.

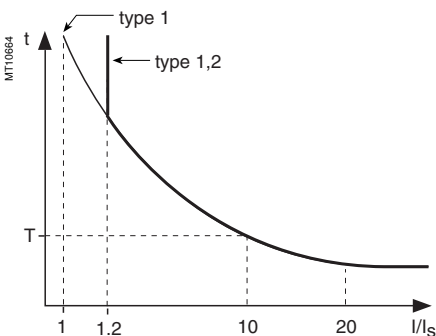

IDMT protection principle.

The I_s setting corresponds to the vertical asymptote of the curve, and T is the operation time delay for 10 I_s . The tripping time for I/I_s values less than 1.2 depends on the type of curve chosen.

Curve description	Type
Standard inverse time (SIT)	1.2
Very inverse time (VIT or LTI)	1.2
Extremely inverse time (EIT)	1.2
Ultra inverse time (UIT)	1.2
RI curve	1
IEC standard inverse time SIT/A	1
IEC very inverse time VIT or LTI/B	1
IEC extremely inverse time EIT/C	1
IEEE moderately inverse (IEC/D)	1
IEEE very inverse (IEC/E)	1
IEEE extremely inverse (IEC/F)	1
IAC inverse	1
IAC very inverse	1
IAC extremely inverse	1

The curve equations are given in the chapter entitled "IDMT protection functions".

The function takes into account current variations during the time delay interval. For currents with a very large amplitude, the protection function has a definite time characteristic:

- if $I > 20 I_s$, tripping time is the time that corresponds to 20 I_s
- if $I > 40 I_n$, tripping time is the time that corresponds to 40 I_n (I_n : rated current transformer current defined when entering the general settings).

Block diagram

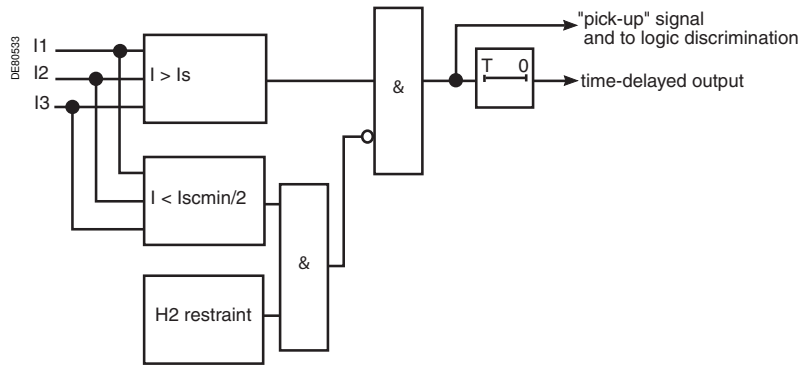

Timer hold delay

The function includes an adjustable timer hold delay T1:

- definite time (timer hold) for all the tripping curves

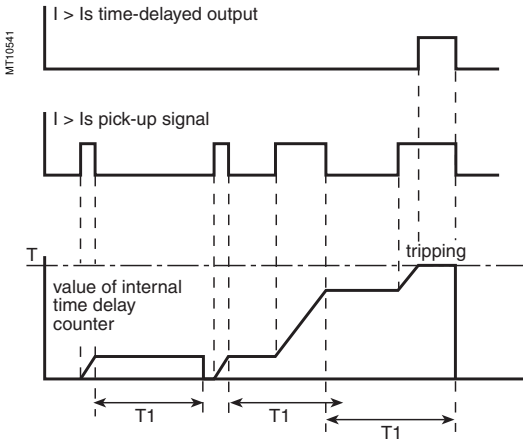

- IDMT for IEC, IEEE and IAC curves

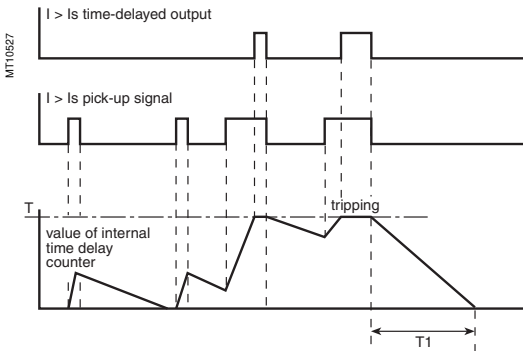

Characteristics

Tripping curve	
Setting	Definite time, IDMT: chosen according to list on page 72

Confirmation	
Setting	by undervoltage (unit 1) by negative sequence overvoltage none, by confirmation

Is set point	
Setting	Definite time 0.1 In ≤ Is ≤ 24 In expressed in Amps IDMT 0.1 In ≤ Is ≤ 2.4 In expressed in Amps
Resolution	1 A or 1 digit
Accuracy (1)	±5 % or ±0.01 In
Drop out/pick-up ratio	93.5 % ±5 % or > (1 - 0.015 In/Is) x 100 %

Time delay T (operation time at 10 Is)	
Setting	Definite time inst., 50 ms ≤ T ≤ 300 s IDMT 100 ms ≤ T ≤ 12.5 s or TMS (2)
Resolution	10 ms or 1 digit
Accuracy (1)	Definite time ±2 % or from -10 ms to +25 ms IDMT Class 5 or from -10 ms to +25 ms

Timer hold delay T1	
Definite time (timer hold)	0; 0.05 to 300 s
IDMT (3)	0.5 to 20 s

Characteristic times	
Operation time	Pick-up < 35 ms at 2 Is (typically 25 ms) Confirmed instantaneous: ■ inst. < 50 ms at 2 Is for Is ≥ 0.3 In (typically 35 ms) ■ inst. < 70 ms at 2 Is for Is < 0.3 In (typically 50 ms)
Overshoot time	< 35 ms
Reset time	< 50 ms (for T1 = 0)

Harmonic restraint 2	
Set point	5 to 50%

Minimum short-circuit current Isc	
Setting	In to 999 kA

- 1) In reference conditions (IEC 60255-6).
- 2) Setting ranges in TMS (Time Multiplier Setting) mode
 - Inverse (SIT) and IEC SIT/A: 0.04 to 4.20
 - Very inverse (VIT) and IEC VIT/B: 0.07 to 8.33
 - Very inverse (LTI) and IEC LTI/B: 0.01 to 0.93
 - Ext inverse (EIT) and IEC EIT/C: 0.13 to 15.47
 - IEEE moderately inverse: 0.42 to 51.86
 - IEEE very inverse: 0.73 to 90.57
 - IEEE extremely inverse: 1.24 to 154.32
 - IAC inverse: 0.34 to 42.08
 - IAC very inverse: 0.61 to 75.75
 - IAC extremely inverse: 1.08 to 134.4
- 3) Only for standardized tripping curves of the IEC, IEEE and IAC types.

TS/TC equivalence for each protocol

Modbus	DNP3	IEC 60870-5-103	IEC 61850
TC	Binary Output	ASDU, FUN, INF	LN.DO.DA
TC3	BO08	20, 160, 23	LLN0.SGCB.SetActiveSettingGroup
TC4	BO09	20, 160, 24	LLN0.SGCB.SetActiveSettingGroup

Description

The Cold Load Pick-Up I or CLPU 50/51 function avoids nuisance tripping of the phase overcurrent protection (ANSI 50/51), during energization after a long outage. Depending on the installation characteristics, these operations can actually generate transient inrush currents likely to exceed the protection set points.

These transient currents may be due to:

- the power transformer magnetizing currents
- the motor starting currents
- simultaneous resetting of all the loads in the installation (air conditioning, heating, etc.).

In principle, the protection settings should be defined so as to avoid tripping due to these transient currents. However, if these settings result in inadequate sensitivity levels or delays that are too long, the CLPU 50/51 function can be used to increase or inhibit set points temporarily after energization.

Operation

The CLPU 50/51 function starts if one of the following three conditions is fulfilled:

- a phase current is detected after all the currents have disappeared for longer than the time before activation T_{cold}
- a logic input (I24 by default) has been activated, indicating a temporary overload due to starting of the load corresponding to the protected feeder, or a feeder downstream
- the start command for the CLPU 50/51 function has been activated from the logic equation editor.

This detection results in either, depending on the parameter setting of Global action CLPU 50/51, for a predefined duration:

- application of a configurable multiplying factor to set point I_s of each ANSI 50/51 protection unit
- or blocking of the various protection units.

Setting the CLPU 50/51 function parameters allows the user to:

- define the time before activation T_{cold} and the pick-up threshold CLPUs
 - choose which ANSI 50/51 protection units it affects
 - define the type of action (multiplying factor or blocking), its duration T/x and if necessary, the multiplying factor M/x for each ANSI 50/51 protection unit x
- By default the CLPU 50/51 function is off.

Block diagram

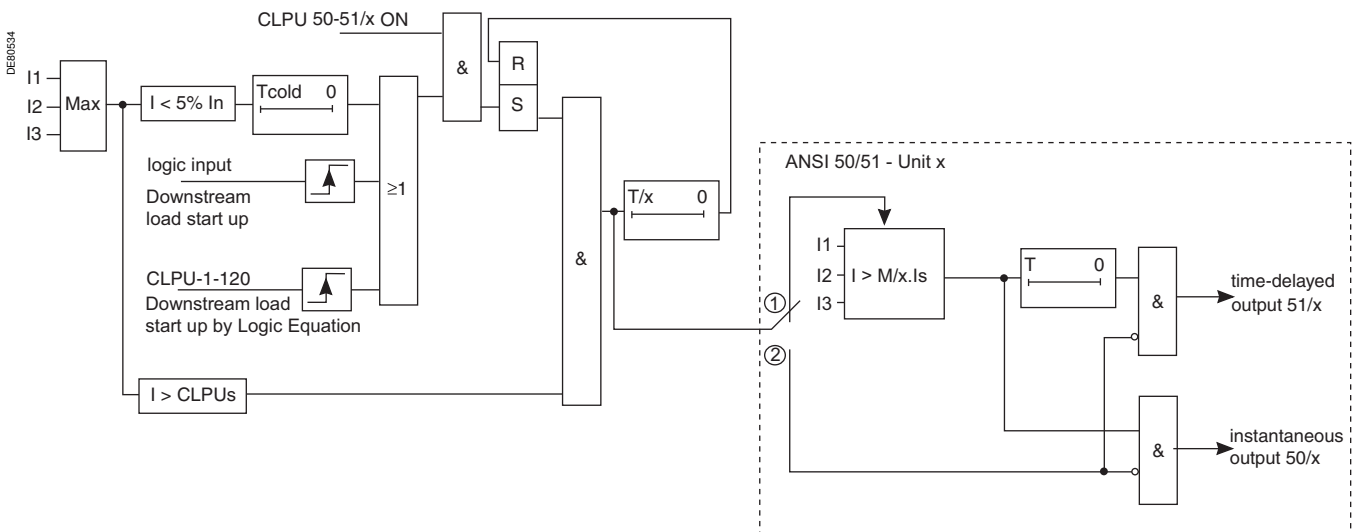

Action of the CLPU 50/51 function on set point I_s of ANSI 50/51 protection unit x during time delay T/x depends on the Global action CLPU 50/51 setting:

- ① multiplication of set point I_s by a coefficient M/x
- ② blocking

Phase overcurrent Cold Load Pick-Up/Blocking CLPU 50/51

Characteristics

Time before activation Tcold (Setting common to CLPU 50/51 and CLPU 50N/51N functions)	
Setting	0.1 to 300 s
Resolution	10 ms
Accuracy	±2% or ±20 ms
Pick-up threshold CLPUs (Setting common to CLPU 50/51 and CLPU 50N/51N functions)	
Setting	10 to 100% I _n
Resolution	1% I _n
Accuracy	±5% or ±1% I _n
Global action CLPU 50/51	
Setting	Blocking/Multiplication of the set point
Action on ANSI 50/51 protection unit x	
Setting	OFF/ON
Time delay T/x for ANSI 50/51 protection unit x	
Resolution setting	100 to 999 ms in 1 ms steps
	1 to 999 s in 1 s steps
	1 to 999 min in 1 min steps
Accuracy	±2% or ±20 ms
Multiplying factor M/x for ANSI 50/51 protection unit x	
Setting	100 to 999% I _s
Resolution	1% I _s

Operation

This function is designed to detect the failure of breakers that do not open when a tripping order is sent.

The "breaker failure" protection function is activated by an O1 output tripping order received from the overcurrent protection functions (50/51, 50N/51N, 46, 67N, 67). It checks for the disappearance of current during the time interval specified by the time delay T. It may also take into account the position of the circuit breaker read on the logic inputs to determine the actual opening of the breaker. Wiring a volt-free closed circuit breaker position contact on the "breaker closed" equation editor input can ensure that the protection is effective in the following situations:

- When 50BF is activated by protection function 50N/51N (set point $I_{s0} < 0.2 I_n$), detection of the 50BF current set point can possibly be not operational.
- When trip circuit supervision (TCS) is used, the closed circuit breaker contact is short-circuited. Logic input I102 is therefore no longer operational.

Automatic activation of this protection function requires the use of the program logic circuit breaker control function. A specific input may also be used to activate the protection from the equation editor. That option is useful for adding special cases of activation (e.g. tripping by an external protection unit).

The time-delayed output of the protection unit should be assigned to a logic output via the control matrix.

The starting and stopping of the time delay T counter are conditioned by the presence of a current above the set point ($I > I_s$).

Block diagram

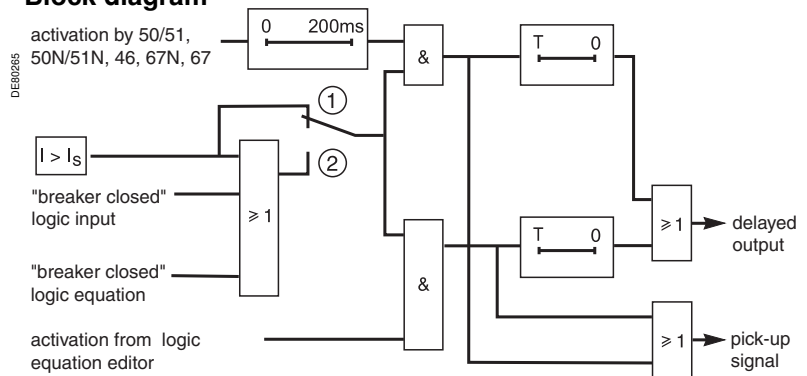

- Setting:
- ① Not accounting for the circuit breaker position
 - ② Accounting for the circuit breaker position

Example of setting

The example below shows how to determine the time delay setting for the 50BF function

Overcurrent protection setting: $T = \text{inst.}$

Circuit breaker operating time: 60 ms.

Auxiliary relay operating time to open the upstream breaker or breakers: 10 ms.

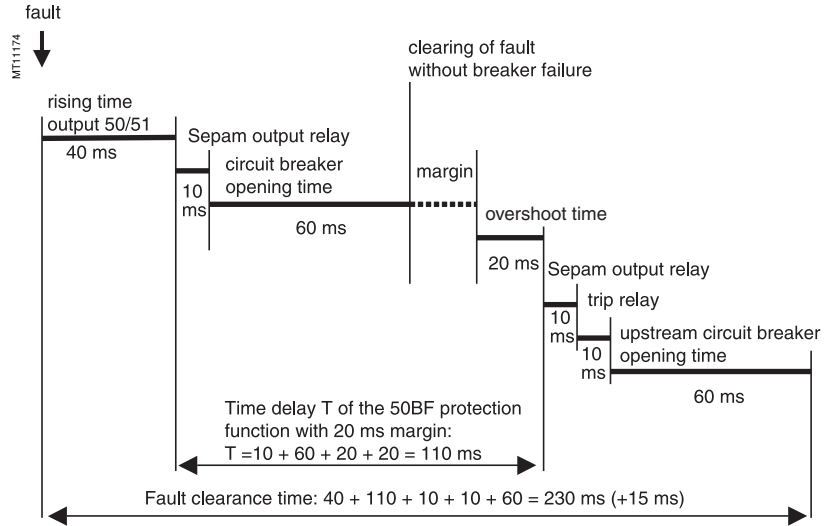

The time delay for the 50BF function is the sum of the following times:

Sepam O1 output relay pick-up time = 10 ms

Circuit breaker opening time = 60 ms

Overshoot time for the breaker failure function = 20 ms

To avoid unwanted tripping of the upstream breakers, choose a margin of approximately 20 ms.

This gives us a time delay $T = 110$ ms.

Characteristic

Is set point	
Setting	0.2 In to 2 In
Accuracy (1)	$\pm 5\%$
Resolution	0.1 A
Drop out/pick-up ratio	$(87.5 \pm 10)\%$
Time delay T	
Setting	0,05 s to 300 s
Accuracy (1)	$\pm 2\%$, or from 0 ms to 15 ms
Resolution	10 ms or 1 digit
Characteristic time	
Overshoot time	< 20 ms
Taking into account of circuit breaker position	
Setting	With / without

(1) In reference conditions (IEC 60255-6)

Description

The earth fault protection function comprises 2 groups of four units, called Group A and Group B respectively. The mode of switching from one group to the other may be determined by parameter setting:

- by remote control (TC3, TC4)
- by logic input I13 (I13 = 0 group A, I13 = 1 group B)
- or by forcing the use of the group.

Operation

Earth fault protection is single-phase. It picks up if the earth fault current reaches the operation set point. It includes a time delay, which is either definite (constant, **DT**) or IDMT depending on the curves on the facing page. The protection function includes a harmonic 2 restraint which can be used to bypass the incorrect residual current on the sum of the 3 phase CTs when the transformers are energized. The restraint can be selected by parameter setting. The principle of this harmonic 2 restraint allows this protection to trip on intermittent earth faults.

Definite time protection

I_{s0} is the operation set point expressed in Amps, and T is the protection operation time delay.

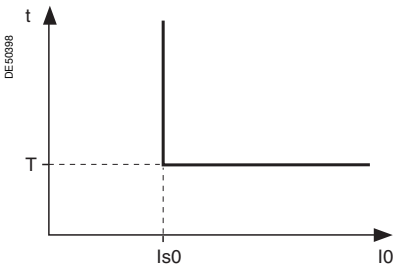

Definite time protection principle.

IDMT protection

IDMT protection operates in accordance with the IEC 60255-3, BS 142 and IEEE C-37.112 standards.

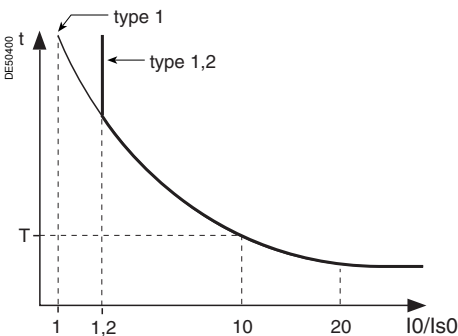

IDMT protection principle.

The I_{s0} setting is the vertical asymptote of the curve, and T is the operation time delay for $10 I_{s0}$.

The tripping time for I_0/I_{s0} values of less than 1.2 depends on the type of curve chosen.

Name of curve	Type
Standard inverse time (SIT)	1.2
Very inverse time (VIT or LTI)	1.2
Extremely inverse time (EIT)	1.2
Ultra inverse time (UIT)	1.2
RI curve	1
IEC standard inverse time SIT / A	1
IEC very inverse time VIT or LTI / B	1
IEC extremely inverse time EIT / C	1
IEEE moderately inverse (IEC / D)	1
IEEE very inverse (IEC / E)	1
IEEE extremely inverse (IEC / F)	1
IAC inverse	1
IAC very inverse	1
IAC extremely inverse	1

The curve equations are given in the chapter entitled "IDMT protection functions".

The function takes into account current variations during the time delay interval.

For currents with a very large amplitude, the protection function has a definite time characteristic:

- if $I > 20 I_{s0}$, tripping time is the time that corresponds to $20 I_{s0}$
- if $I > 20 I_{n0}$, tripping time is the time that corresponds to $20 I_{n0}$ (operation based on I_0 input)
- if $I > 40 I_{n0}$, tripping time is the time that corresponds to $40 I_{n0}$ (operation based on sum of phase currents).

Block diagram

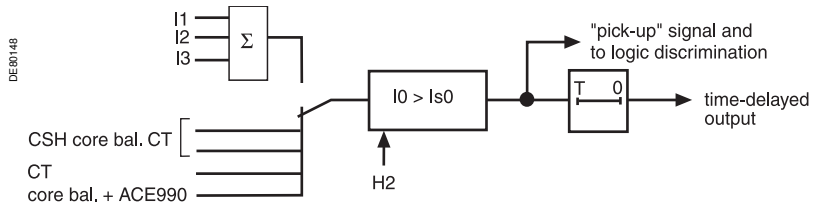

The choice between I_0 (measured) and $I_0\Sigma$ (calculated by the sum of the phase currents) may be set for each unit, by default units 1 and 2 set to I_0 and units 2 and 4 to $I_0\Sigma$.

By mixing the 2 possibilities on the different units, it is possible to have:

- different dynamic set points
- different applications, e.g. zero sequence and tank earth leakage protection.

Timer hold delay

The function includes an adjustable timer hold delay T1:

- definite time (timer hold) for all the tripping curves

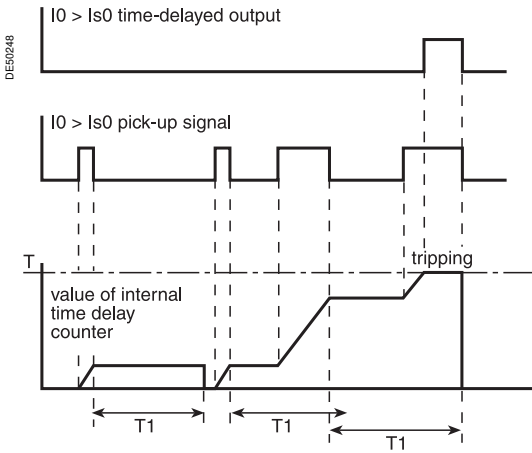

- DMT for IEC, IEEE and IAC curves.

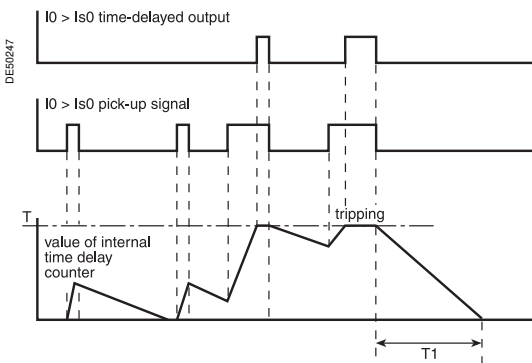

(1) $I_{n0} = I_n$ if the sum of the three phase currents is used for the measurement.

I_{n0} = sensor rating if the measurement is taken by a CSH core balance CT.

$I_{n0} = I_n$ of the CT at $I_n/10$ according to parameter setting if the measurement is taken by a 1 A or 5 A current transformer.

(2) I_n reference conditions (IEC 60255-6)

(3) Setting ranges in TMS (Time Multiplier Setting) mode

Inverse (SIT) and IEC/IEC SIT/A: 0.04 to 4.20

Very inverse (VIT) and IEC VIT/B: 0.07 to 8.33

Very inverse (LTI) and IEC LTI/B: 0.01 to 0.93

Ext inverse (EIT) and IEC EIT/C: 0.13 to 15.47

IEEE moderately inverse: 0.42 to 51.86

IEEE very inverse: 0.73 to 90.57

IEEE extremely inverse: 1.24 to 154.32

IAC inverse: 0.34 to 42.08

IAC very inverse: 0.61 to 75.75

IAC extremely inverse: 1.08 to 134.4

(4) Only for standardized tripping curves of the IEC, IEEE and IAC types.

(5) For $I_{s0} < 0.4 I_{n0}$, the minimum time delay is 300 ms.

If a shorter time delay is needed, use the CT + CSH30 or CT + CCA634 combination.

Characteristics

Tripping curve		
Setting		Definite time, IDMT: chosen according to list page 78
Is0 set point		
Definite time setting		$0.1 I_{n0} \leq I_{s0} \leq 15 I_{n0}$ (1) expressed in Amps
Sum of CTs (5)		$0.1 I_{n0} \leq I_{s0} \leq 15 I_{n0}$
With CSH sensor		
2 A rating		0.2 A to 30 A
5 A rating		0.5 A to 75 A
20 A rating		2 A to 300 A
CT		$0.1 I_{n0} \leq I_{s0} \leq 15 I_{n0}$ (min. 0.1 A)
Core balance CT with ACE990		$0.1 I_{n0} < I_{s0} < 15 I_{n0}$
IDMT time setting		$0.1 I_{n0} \leq I_{s0} \leq I_{n0}$ (1) expressed in Amps
Sum of CTs (5)		$0.1 I_{n0} \leq I_{s0} \leq I_{n0}$
With CSH sensor		
2 A rating		0.2 A to 2 A
5 A rating		0.5 A to 5 A
20 A rating		2 A to 20 A
CT		$0.1 I_{n0} \leq I_{s0} \leq I_{n0}$ (min. 0.1 A)
Core balance CT with ACE990		$0.1 I_{n0} < I_{s0} < I_{n0}$
Resolution		0.1 A or 1 digit
Accuracy (2)		$\pm 5\%$ or $\pm 0.01 I_{n0}$
Drop out/pick-up ratio		$93.5\% \pm 5\%$ (with CSH sensor, CT or core balance CT + ACE990) $93.5\% \pm 5\%$ or $> (1 - 0.015 I_{n0}/I_{s0}) \times 100\%$ (sum of CTs)
Harmonic 2 restraint		
Fixed threshold		$20\% \pm 5\%$
Time delay T (operation time at 10 Is0)		
Setting	Definite time	inst. $50 \text{ ms} \leq T \leq 300 \text{ s}$
	IDMT	$100 \text{ ms} \leq T \leq 12.5 \text{ s}$ or TMS (3)
Resolution		10 ms or 1 digit
Accuracy (2)	Definite time	$\pm 2\%$ or from -10 ms to +25 ms
	IDMT	class 5 or from -10 ms to +25 ms
Timer hold delay T1		
Definite time (timer hold)		0; 0.05 to 300 s
IDMT (4)		0.5 to 20 s
Characteristic times		
Operation time		Pick-up < 35 ms at 2 Is0 (typically 25 ms) Confirmed instantaneous: ■ inst. < 50 ms at 2 Is0 for $I_{s0} \geq 0.3 I_{n0}$ (typically 35 ms) ■ inst. < 70 ms at 2 Is0 for $I_{s0} < 0.3 I_{n0}$ (typically 50 ms)
Overshoot time		< 35 ms
Reset time		< 40 ms (for $T1 = 0$)

TS/TC equivalence for each protocol

Modbus	DNP3	IEC 60870-5-103	IEC 61850
TC	Binary Output	ASDU, FUN, INF	LN.DO.DA
TC3	BO08	20, 160, 23	LLN0.SGCB.SetActiveSettingGroup
TC4	BO09	20, 160, 24	LLN0.SGCB.SetActiveSettingGroup

Description

The Cold Load Pick-Up I0 or CLPU 50N/51N function avoids nuisance tripping of the earth fault protection (ANSI 50N/51N) during energization after a long outage.

Depending on the installation characteristics, such operations can actually generate transient inrush currents.

If the residual current measurement is based on the sum of the 3 phase CTs, the aperiodic component of these transient currents can result in saturation of the phase CTs, which can result in a residual current measurement likely to exceed the protection set points. These transient currents are essentially due to:

- the power transformer magnetizing currents
- the motor starting current.

In principle, the protection settings should be defined so as to avoid tripping due to these transient currents. However, if these settings result in inadequate sensitivity levels or delays that are too long, the CLPU 50N/51N function is used to increase or inhibit set points temporarily after energization.

If the residual current is measured by a correctly installed CT, there is less risk of measuring an incorrect residual current. In this case, there is no need to use the CLPU 50N/51N function.

Operation

The CLPU 50N/51N function starts if one of the following three conditions is fulfilled:

- a phase current is detected after all the currents have disappeared for longer than the time before activation T_{cold}
- a logic input (I24 by default) has been activated, indicating a temporary overload due to starting of the load corresponding to the protected feeder, or a feeder downstream
- the start command for the CLPU 50N/51N function has been activated from the logic equation editor.

This detection results in either, depending on the parameter setting of Global action CLPU 50N/51N, for a predefined duration:

- application of a configurable multiplying factor to set point $Is0$ of each ANSI 50N/51N protection unit
- or blocking of the various protection units

Setting the CLPU 50N/51N function parameters consists of:

- defining the time before activation T_{cold} and the pick-up threshold CLPUs
- choosing which ANSI 50N/51N protection units it affects
- defining the type of action (multiplying factor or blocking), its duration $T0/x$ and if necessary, the multiplying factor $M0/x$ for each ANSI 50N/51N protection unit x .
By default the CLPU 50N/51N function is off.

Setting assistance

During use with multiplying factor $M0/x$, it is advisable to set the $Is0$ set point of the 50N/51N protection unit higher than the pick-up threshold CLPUs.

Block diagram

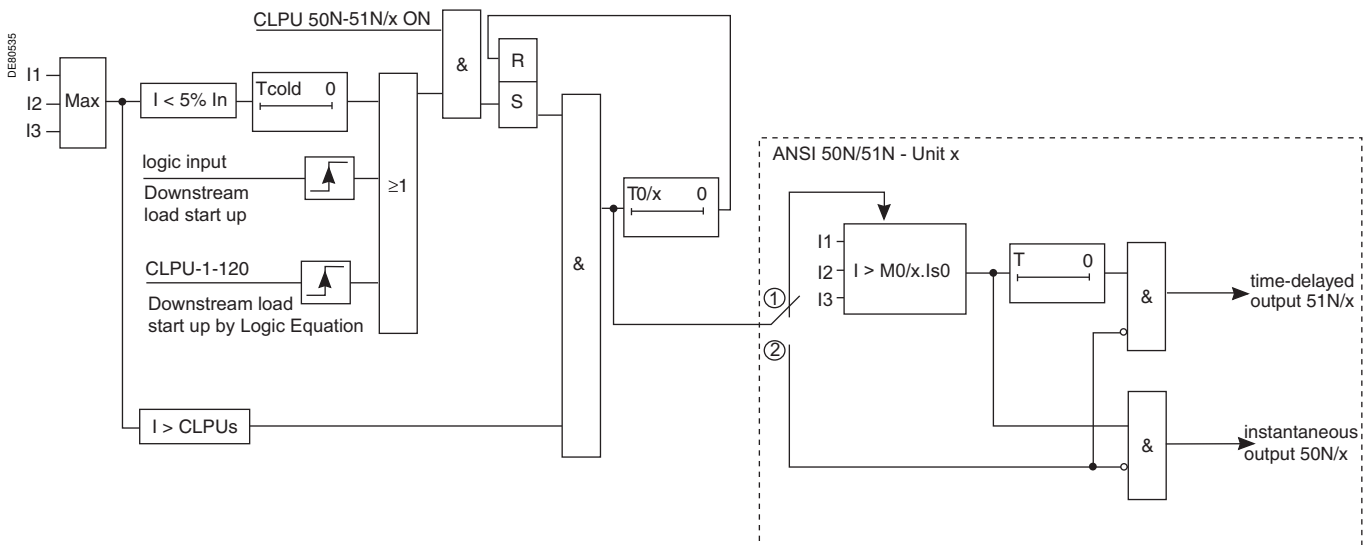

Action of the CLPU 50N/51N function on set point $Is0$ of ANSI 50N/51N protection unit x during time delay $T0/x$ depends on the Global action CLPU 50N/51N setting:

- ① multiplication of set point $Is0$ by a coefficient $M0/x$
- ② blocking

Earth fault Cold Load Pick-Up/ Blocking CLPU 50N/51N

Characteristics

Time before activation Tcold (Setting common to CLPU 50/51 and CLPU 50N/51N functions)	
Setting	0.1 to 300 s
Resolution	10 ms
Accuracy	±2% or ±20 ms
Pick-up threshold CLPUs (Setting common to CLPU 50/51 and CLPU 50N/51N functions)	
Setting	10 to 100% I _n
Resolution	1% I _n
Accuracy	±5% or ±1% I _n
Global action CLPU 50N/51N	
Setting	Blocking/Multiplication of the set point
Action on ANSI 50N/51N protection unit x	
Setting	OFF/ON
Time delay T0/x for ANSI 50N/51N protection unit x	
Resolution setting	100 to 999 ms in 1 ms steps
	1 to 999 s in 1 s steps
	1 to 999 min in 1 min steps
Accuracy	±2% or ±20 ms
Multiplying factor M0/x for ANSI 50N/51N protection unit x	
Setting	100 to 999% I _{s0}
Resolution	1% I _s

Operation

The voltage-restrained phase overcurrent protection function is used to protect generators. The operation set point is adjusted according to the voltage to take into account cases of faults close to the generator which cause voltage dips and short-circuit current. This protection function is three-pole. It picks up if one, two or three phase currents reach the voltage-adjusted operation set point I_s^* . The alarm linked to operation indicates the faulty phase or phases. It is time-delayed, and the time delay may be definite time (DT) or IDMT according to the curves opposite. The set point is adjusted according to the lowest of the phase-to-phase voltages measured. The adjusted set point I_s^* is defined by the following equation:

$$I_s^* = \frac{I_s}{3} \times \left(4 \frac{U}{U_N} - 0.2 \right)$$

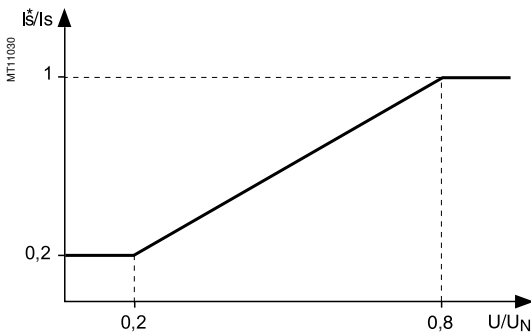

Definite time protection

I_s is the operation set point expressed in Amps, and T is the protection operation time delay.



Definite time protection principle.

IDMT protection

IDMT protection operates in accordance with the IEC 60255-3, BS 142 and IEEE C-37.112 standards.

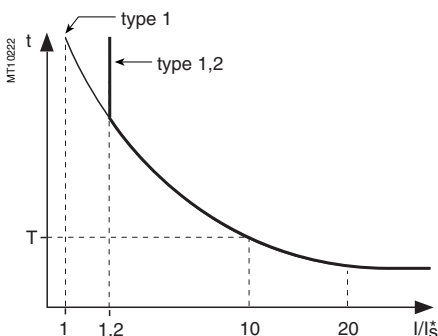

IDMT protection principle.

The I_{s0} setting is the vertical asymptote of the curve, and T is the operation time delay for $10 I_{s0}$.

The tripping time for I_0/I_{s0} values of less than 1.2 depends on the type of curve chosen.

Name of curve	Type
Standard inverse time (SIT)	1.2
Very inverse time (VIT or LTI)	1.2
Extremely inverse time (EIT)	1.2
Ultra inverse time (UIT)	1.2
RI curve	1
IEC standard inverse time SIT / A	1
IEC very inverse time VIT or LTI / B	1
IEC extremely inverse time EIT / C	1
IEEE moderately inverse (IEC / D)	1
IEEE very inverse (IEC / E)	1
IEEE extremely inverse (IEC / F)	1
IAC inverse	1
IAC very inverse	1
IAC extremely inverse	1

The curve equations are given in the chapter entitled "IDMT protection functions".

The function takes into account current variations during the time delay interval.

For currents with a very large amplitude, the protection function has a definite time characteristic:

- if $I > 20 I_s$, tripping time is the time that corresponds to $20 I_s$
- if $I > 40 I_n$, tripping time is the time that corresponds to $40 I_n$ (I_n : current transformer rated current defined when the general settings are made).

Block diagram

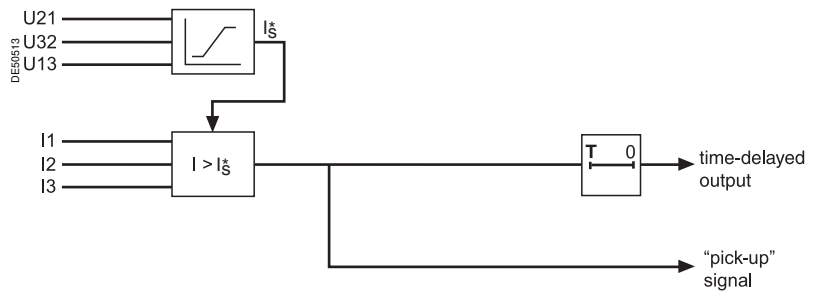

Timer hold delay

The function includes an adjustable timer hold delay T1:

- definite time (timer hold) for all the tripping curves

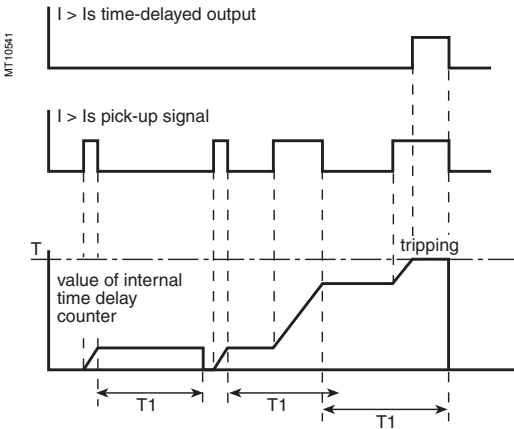

■ IDMT for IEC, IEEE and IAC curves

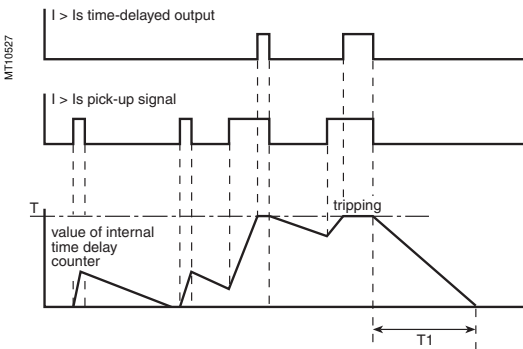

Characteristics

Tripping curve		
Setting		Definite time, IDMT: chosen according to list page 82
Is set point		
Setting	Definite time	$0.5 I_n \leq I_s \leq 24 I_n$ expressed in Amps
	IDMT	$0.5 I_n \leq I_s \leq 2.4 I_n$ expressed in Amps
Resolution		1 A or 1 digit
Accuracy (1)		$\pm 5\%$ or $\pm 0.01 I_n$
Drop out/pick-up ratio		$93.5\% \pm 5\%$ or $> (1 - 0.015 I_n/I_s^*) \times 100\%$
Time delay T (operation time at 10 Is0)		
Setting	Definite time	inst. $50 \text{ ms} \leq T \leq 300 \text{ s}$
	IDMT	$100 \text{ ms} \leq T \leq 12.5 \text{ s}$ or TMS (2)
Resolution		10 ms or 1 digit
Accuracy (1)	Definite time	$\pm 2\%$ or from -10 ms to +25 ms
	IDMT	class 5 or from -10 ms to +25 ms
Timer hold delay T1		
Definite time (timer hold)		0; 0.05 to 300 s
IDMT (3)		0.5 to 20 s
Characteristic times		
Operation time		pick-up < 35 ms at 2 Is (typically 25 ms) Confirmed instantaneous: ■ inst. < 50 ms at 2 Is* for Is* > 0.3 In (typically 35 ms) ■ inst. < 70 ms at 2 Is* for Is* ≤ 0.3 In (typically 50 ms)
Overshoot time		< 35 ms
Reset time		< 50 ms (for T1 = 0)
(1) In reference conditions (IEC 60255-6)		
(2) Setting ranges in TMS (Time Multiplier Setting) mode		
Inverse (SIT) and IECIEC SIT/A: 0.04 to 4.20		
Very inverse (VIT) and IEC VIT/B: 0.07 to 8.33		
Very inverse (LTI) and IEC LTI/B: 0.01 to 0.93		
Ext inverse (EIT) and IEC EIT/C: 0.13 to 15.47		
IEEE moderately inverse: 0.42 to 51.86		
IEEE very inverse: 0.73 to 90.57		
IEEE extremely inverse: 1.24 to 154.32		
IAC inverse: 0.34 to 42.08		
IAC very inverse: 0.61 to 75.75		
IAC extremely inverse: 1.08 to 134.4		
(3) Only for standardized tripping curves of the IEC, IEEE and IAC types.		

Operation

The protection function is single-phase and operates with phase-to-neutral or phase-to-phase voltage:

- it picks up if one of the voltages concerned is above the U_s (or V_s) set point
- it includes a definite time delay T
- with phase-to-neutral operation, it indicates the faulty phase in the alarm associated with the fault.

Block diagram

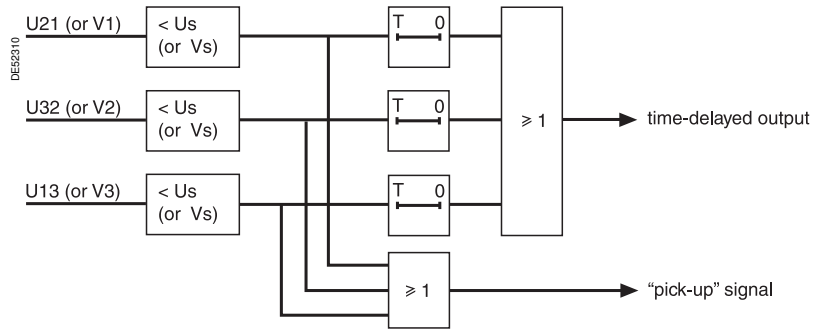

Characteristics

Us (or Vs) set point	
Setting	50 to 150% U_{np} (or V_{np}) if $U_{ns} < 208$ V 50 to 135% U_{np} (or V_{np}) if $U_{ns} \geq 208$ V
Accuracy ⁽¹⁾	± 2 % or $\pm 0.005 U_{np}$
Resolution	1 %
Drop out/pick up ratio	97 % ± 1 %
Time delay T	
Setting	50 ms to 300 s
Accuracy ⁽¹⁾	± 2 %, or ± 25 ms
Resolution	10 ms or 1 digit
Characteristic times	
Operation time	pick-up < 35 ms (typically 25 ms)
Overshoot time	< 35 ms
Reset time	< 40 ms

(1) In reference conditions (IEC 60255-6).

Connection conditions					
Type of connection	V1, V2, V3	U21	U21, U32	U21 + V0	U21, U32 + V0
Phase-to-neutral operation	Yes	No	No	No	Yes
Phase-to-phase operation	Yes	on U21 only	Yes	on U21 only	Yes

Operation

The protection function picks up if the residual voltage V_0 is above a V_{s0} set point,

$$\vec{V}_0 = \vec{V}_1 + \vec{V}_2 + \vec{V}_3,$$

- it includes a definite time delay T .
- the residual voltage is either calculated from the 3 phase voltages or measured by an external VT
- the protection function operates for connections: V1V2V3, U21U32 + V_0 and U21 + V_0 .

Block diagram

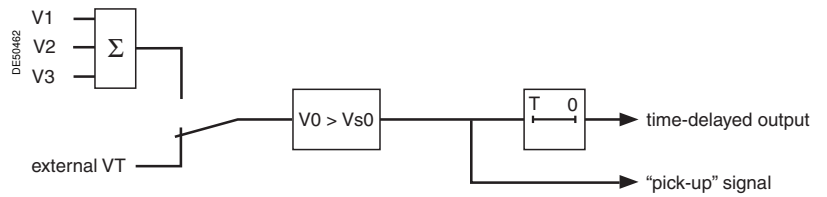

Characteristics

Vs0 set point	
Setting	2 % Unp to 80 % Unp if $V_{nso}^{(2)} = \text{sum of } 3V_s$ 2 % Unp to 80 % Unp if $V_{nso}^{(2)} = \text{Uns} / \sqrt{3}$ 5 % Unp to 80 % Unp if $V_{nso}^{(2)} = \text{Uns} / 3$
Accuracy ⁽¹⁾	±2 % or ±0.002 Unp
Resolution	1 %
Drop out/pick up ratio	97 % ±1 % or > (1 - 0.001 Unp/Vs0) x 100 %
Temporisation T	
Setting	50 ms to 300 s
Accuracy ⁽¹⁾	±2 %, or ±25 ms
Resolution	10 ms or 1 digit
Characteristic times	
Operation time	pick-up < 35 ms
Overshoot time	< 35 ms
Reset time	< 40 ms

⁽¹⁾ In reference conditions (IEC 60255-6).

⁽²⁾ V_{nso} is one of the general settings.

Operation

This function is three-phase.

It picks up when the number of starts reaches the following limits:

- maximum number of starts (Nt) allowed per period of time (P)
- maximum allowed number of consecutive hot starts (Nh)
- maximum allowed number of consecutive cold starts (Nc).

Starting is detected when the current consumed becomes greater than 10 % of the Ib current.

The number of consecutive starts is the number starts counted during the last P/Nt minutes, Nt being the number of starts allowed per period.

The motor hot state corresponds to the overshooting of the fixed set point (50 % heat rise) of the thermal overload function.

When the motor re-accelerates, it undergoes a stress similar to that of starting without the current first passing through a value less than 10 % of Ib, in which case the number of starts is not incremented.

It is possible however to increment the number of starts when a re-acceleration occurs by a logic data input (logic input "motor re-acceleration").

The "stop/start" time delay T may be used to inhibit starting after a stop until the delay has elapsed.

Use of circuit breaker closed data

In synchronous motor applications, it is advisable to connect the "circuit breaker closed" data to a logic input in order to enable more precise detection of starts. If the "circuit breaker closed" data is not connected to a logic input, the detection of a start is not conditioned by the position of the circuit breaker.

User information

The following information is available for the user:

- the waiting time before a start is allowed
- the number of starts still allowed.

See chapter "Machine operation assistance functions", page 37.

Block diagram

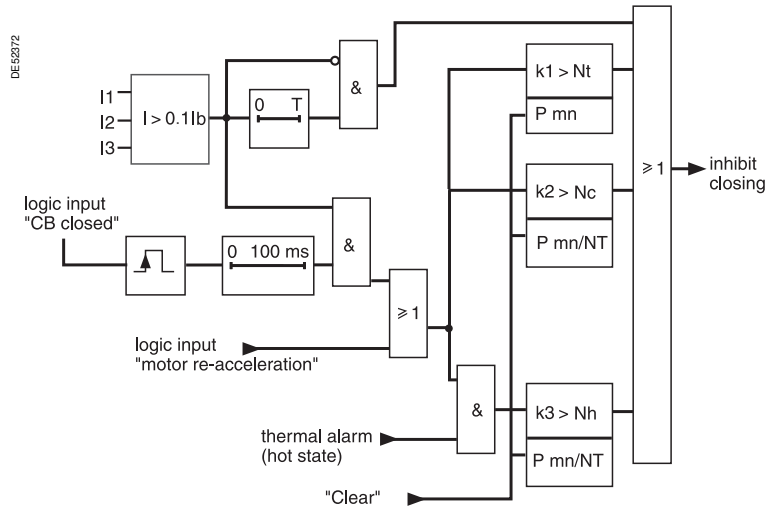

Characteristics

Period of time (P)	
Setting	1 to 6 hr
Resolution	1
Nt total number of starts	
Setting	1 to 60
Resolution	1
Nh and Nc number of consecutive starts	
Setting ⁽¹⁾	1 to Nt
Resolution	1
T time delay stop/start	
Setting	0 mn ≤ T ≤ 90 mn (0: no time delay)
Resolution	1 mn or 1 digit

(1) With Nh ≤ Nc.

Description

The directional phase overcurrent function includes 2 groups of 2 units called respectively Group A and Group B.

The mode for switching from one group to the other may be determined by parameter setting:

- by remote control (TC3, TC4)
- by logic input I13 (I13 = 0 group A, I13 = 1 group B) or by forcing the use of the group.

Operation

This protection function is three-phase. It includes a phase overcurrent function associated with direction detection. It picks up if the phase overcurrent function in the chosen direction (line or busbar) is activated for at least one of the three phases (or two out of three phases, according to parameter setting). The alarm linked to the protection operation indicates the faulty phase or phases.

It is time-delayed and the time delay may be definite time (DT) or IDMT according to the curves page 89. The direction of the current is determined according to the measurement of the phase in relation to a polarization value. It is qualified as busbar direction or line direction according to the following convention:

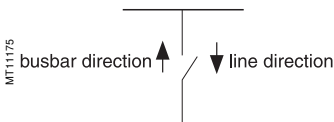

The polarization value is the phase-to-phase value in quadrature with the current for $\cos\phi = 1$ (90° connection angle).

A phase current vector plane is divided into two half-planes that correspond to the line zone and busbar zone. The characteristic angle θ is the angle of the perpendicular to the boundary line between the 2 zones and the polarization value.

Voltage memory

Should all the voltages disappear during a 3-phase fault near the busbar, the voltage level may be insufficient

for the fault direction to be detected ($< 1.5\% U_{np}$).

The protection function therefore uses a voltage memory to reliably determine the direction. The fault direction is saved as long as the voltage level is too low and the current is above the I_s set point.

Closing due to a pre-existing fault

If the circuit breaker is closed due to a pre-existing 3-phase fault on the busbar, the voltage memory is blank. As a result, the direction cannot be determined and the protection does not trip. In such cases, a backup 50/51 protection function should be used.

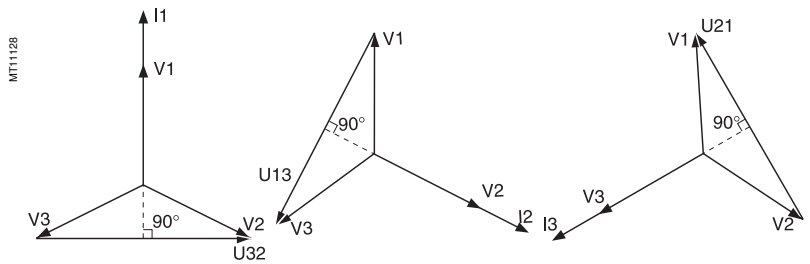

Three-phase function: polarization currents and voltages.

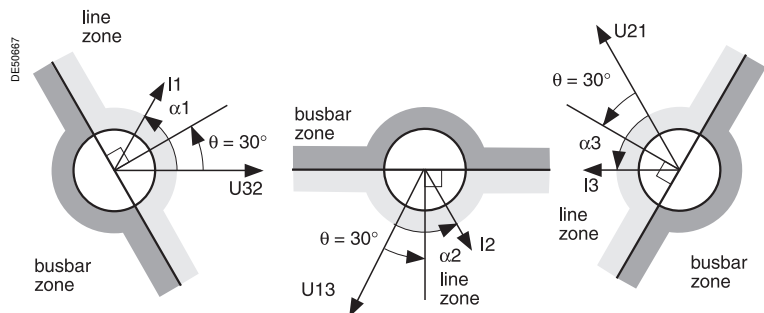

Fault tripping in line zone with $\theta = 30^\circ$.

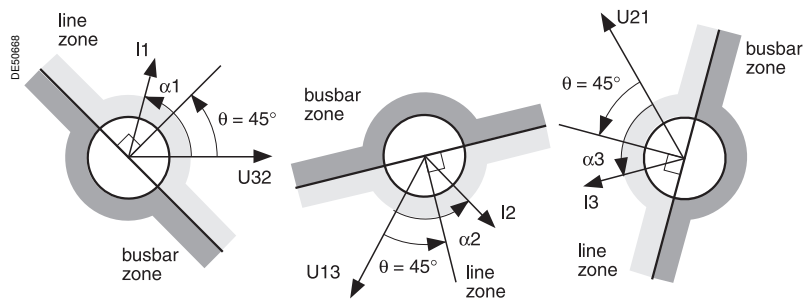

Fault tripping in line zone with $\theta = 45^\circ$.

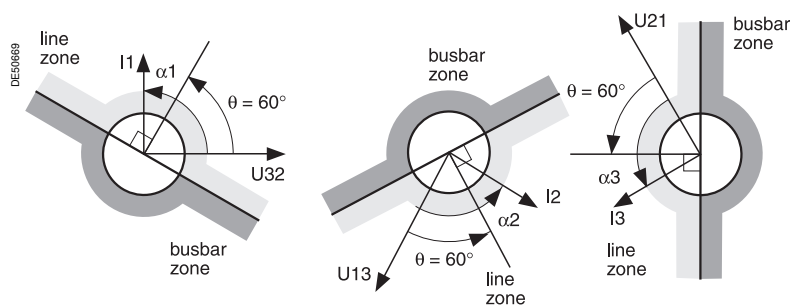

Fault tripping in line zone with $\theta = 60^\circ$.

Block diagram

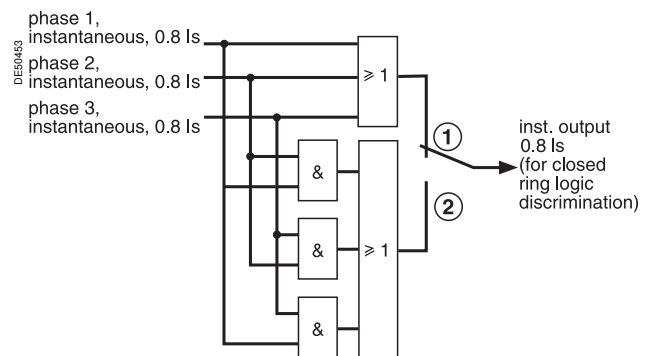
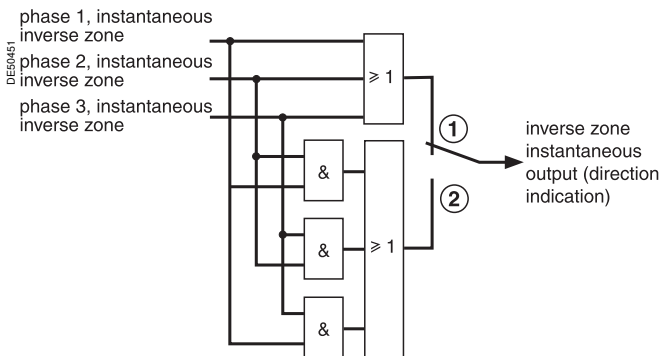
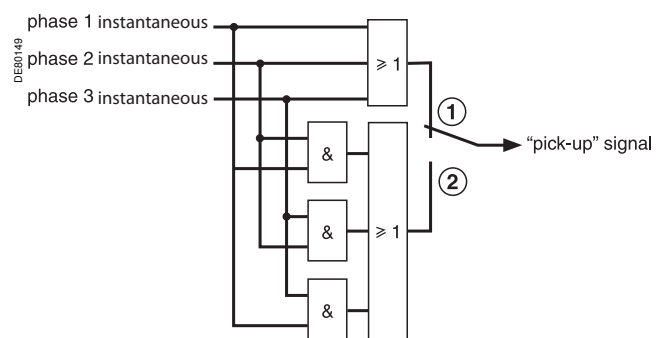
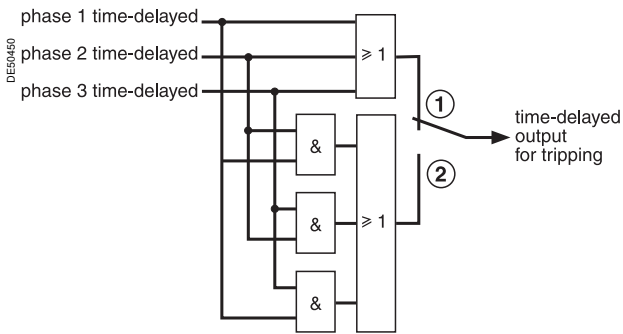
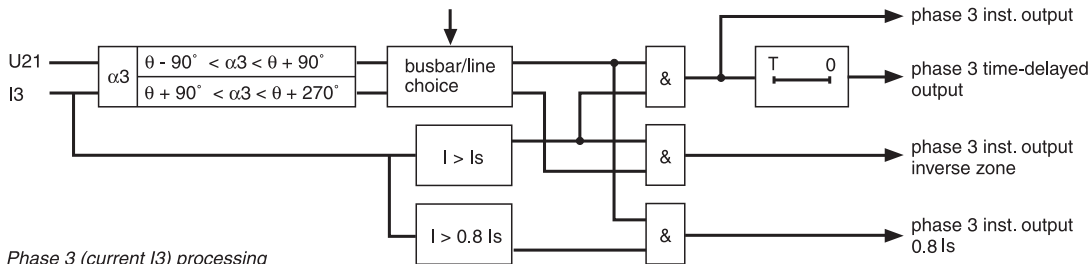
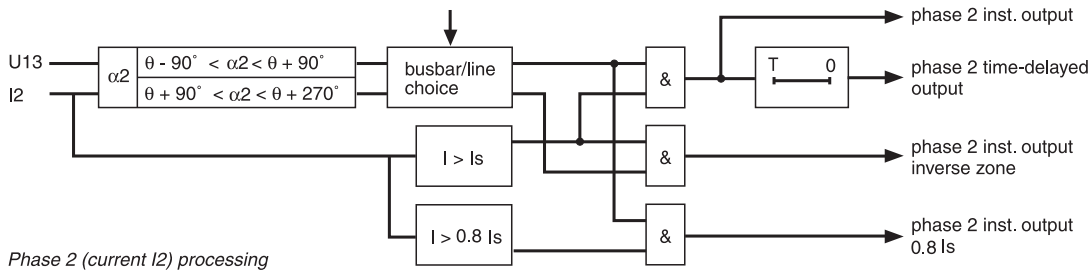
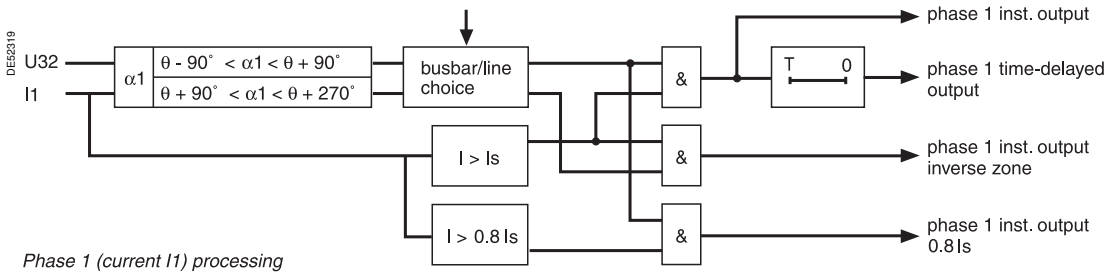

Grouping of output data

Setting of tripping logic:
 ① one out of three
 ② two out of three
 Grouping of output data

Tripping logic

In certain cases, it is wise to choose a tripping logic of the two out of three phases type. Such cases may occur when two parallel transformers (Dy) are being protected. For a 2-phase fault on a transformer primary winding, there is a 2-1-1 ratio current distribution at the secondary end. The highest current is in the expected zone (operation zone for the faulty incomer, no operation zone for the fault-free incomer). One of the lowest currents is at the limit of the zone. According to the line parameters, it may even be in the wrong zone. There is therefore a risk of tripping both incomers.

Time delay

Definite time protection

I_s is the operation set point expressed in Amps, and T is the protection operation time delay.

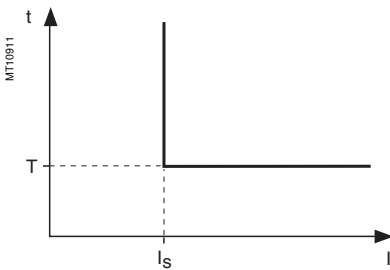

Definite time protection principle.

IDMT protection

IDMT protection operates in accordance with the IEC 60255-3, BS 142 and IEEE C-37112 standards.

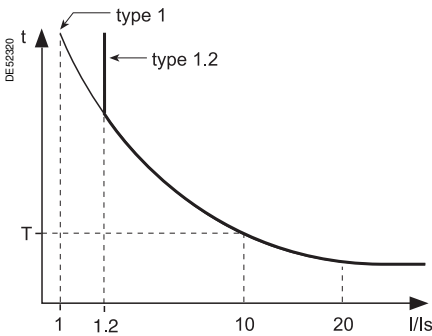

IDMT protection principle.

The I_s setting is the vertical asymptote of the curve, and T is the operation time delay for $10 I_s$.

The tripping time for I/I_s values of less than 1.2 depends on the type of curve chosen.

Name of curve	Type
Standard inverse time (SIT)	1.2
Very inverse time (VIT or LTI)	1.2
Extremely inverse time (EIT)	1.2
Ultra inverse time (UIT)	1.2
RI curve	1
IEC standard inverse time SIT / A	1
IEC very inverse time VIT or LTI / B	1
IEC extremely inverse time EIT / C	1
IEEE moderately inverse (IEC / D)	1
IEEE very inverse (IEC / E)	1
IEEE extremely inverse (IEC / F)	1
IAC inverse	1
IAC very inverse	1
IAC extremely inverse	1

The curve equations are given in the chapter entitled "IDMT protection functions".

The function takes into account current variations during the time delay interval.

For currents with a very large amplitude, the protection function has a definite time characteristic:

- if $I > 20 I_s$, tripping time is the time that corresponds to $20 I_s$
- if $I > 40 I_n$, tripping time is the time that corresponds to $40 I_n$. (I_n : current transformer rated current defined when the general settings are made).

Timer hold delay

The function includes an adjustable timer hold delay T1:

- definite time (timer hold) for all the tripping curves

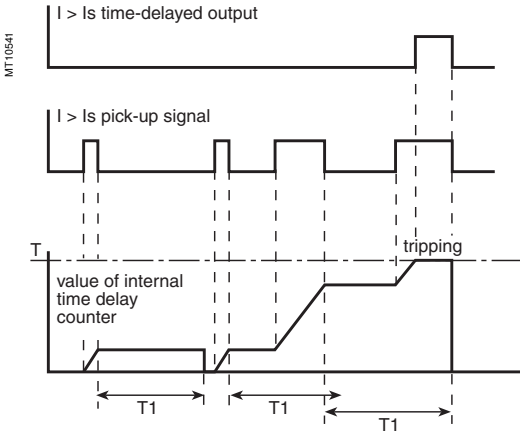

- IDMT for IEC, IEEE and IAC curves

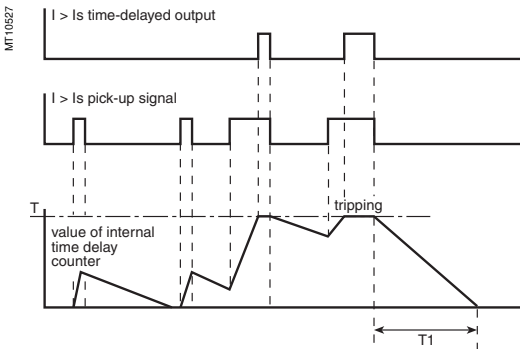

Characteristics

Characteristic angle θ		
Setting		30°, 45°, 60°
Accuracy		±2°
Tripping direction		
Setting		Busbar / line
Tripping logic		
Setting		One out of three / two out of three
Tripping curve		
Setting		Definite time IDMT: chosen according to list page 89
Is set point		
Setting	Definite time	0.1 In ≤ Is ≤ 24 In expressed in Amps
	IDMT	0.1 In ≤ Is ≤ 2.4 In expressed in Amps
Resolution		1 A or 1 digit
Accuracy ⁽¹⁾		±5 % or ±0.01 In
Drop out/pick-up ratio		93.5 % ±5 % or > (1 - 0.015 In/Is) x 100 %
Time delay T (operation time at 10 Is)		
Setting	Definite time	inst., 50 ms ≤ T ≤ 300 s
	IDMT	100 ms ≤ T ≤ 12.5 s or TMS ⁽²⁾
Resolution		10 ms or 1 digit
Accuracy ⁽¹⁾	Definite time	t ≥ 100 ms ±2 % or from -10 ms to +25 ms
	IDMT	Class 5 or from -10 ms to +25 ms
Timer hold delay T1		
Definite time		
(timer hold)		0 ; 0.05 to 300 s
IDMT ⁽³⁾		0.5 to 20 s
Characteristic times		
Operation time		pick-up < 75 ms to 2 Is (typically 65 ms) inst < 90 ms to 2 Is (confirmed instantaneous) (typically 75 ms)
Overshoot time		< 40 ms
Reset time		< 50 ms (for T1 = 0)

(1) In reference conditions (IEC 60255-6).

(2) Setting ranges in TMS (Time Multiplier Setting) mode

- Inverse (SIT) and IEC SIT/A: 0.04 to 4.20
- Very inverse (VIT) and IEC VIT/B: 0.07 to 8.33
- Long time inverse (LTI) and IEC LTI/B: 0.01 to 0.93
- Extremely inverse (EIT) and IEC EIT/C: 0.13 to 15.47
- IEEE moderately inverse: 0.42 to 51.86
- IEEE very inverse: 0.73 to 90.57
- IEEE extremely inverse: 1.24 to 154.32
- IAC inverse: 0.34 to 42.08
- IAC very inverse: 0.61 to 75.75
- IAC extremely inverse: 1.08 to 134.4

(3) Only for standardized tripping curves of the IEC, IEEE and IAC types.

TS/TC equivalence for each protocol

Modbus	DNP3	IEC 60870-5-103	IEC 61850
TC	Binary Output	ASDU, FUN, INF	LN.DO.DA
TC3	BO08	20, 160, 23	LLN0.SGCB.SetActiveSettingGroup
TC4	BO09	20, 160, 24	LLN0.SGCB.SetActiveSettingGroup

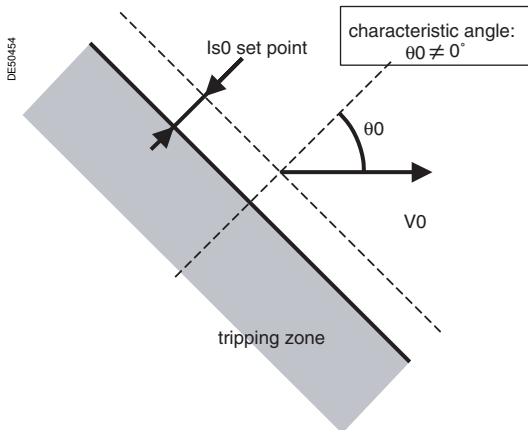

Tripping characteristic of protection function 67N type 1 ($\theta_0 \neq 0^\circ$).

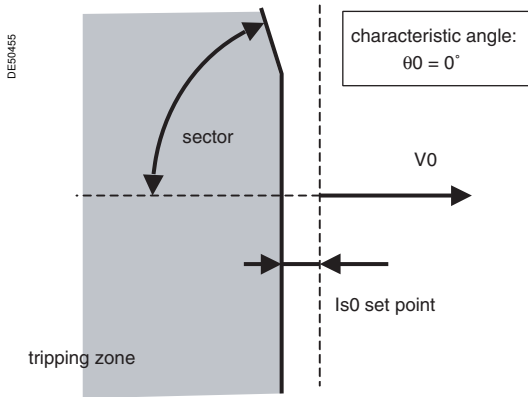

Tripping characteristic of protection function 67N type 1 ($\theta_0 = 0^\circ$).

Description

This function comprises 2 groups of settings, with 2 units for each group. The mode of switching groups of settings may be determined by parameter setting:

- by input I13 (I13 = 0 group A, I13 = 1 group B)
- by remote control (TC3, TC4)
- operation with a single group (group A or group B).

To adapt to all cases of applications and all earthing systems, the protection function operates according to two different types of characteristics, i.e. a choice of:

- type 1: the protection function uses I0 vector projection
- type 2: the protection function uses I0 vector magnitude
- type 3: the protection function uses I0 vector magnitude according to the Italian ENEL DK5600 specification.

Type 1 operation

The function determines the projection of the residual current I0 on the characteristic line, the position of which is set by the setting of characteristic angle θ_0 in relation to the residual voltage. The projection value is compared to the Is0 set point. The projection method is suitable for radial feeders in resistive, isolated or compensated neutral systems.

With compensated neutral systems, it is characterized by its capacity to detect very brief, repetitive faults (recurrent faults). In the case of Petersen coils with no additional resistance, fault detection in steady state operating conditions is not possible due to the absence of active zero sequence current. The protection function uses the transient current at the beginning of the fault to ensure tripping.

The $\theta_0 = 0^\circ$ setting is suitable for compensated neutral systems. When this setting is selected, the parameter setting of the sector is used to reduce the protection tripping zone to ensure its stability on fault-free feeders.

The protection function operates with the residual current measured at the relay I0 input (operation with sum of three currents is impossible). The protection function is inhibited for residual voltages below the Vs0 set point. The time delay is definite time.

When a memory is added, recurrent faults can be detected; the memory is controlled by a time delay or by the residual voltage value. The tripping direction can be set at the busbar end or line end.

Block diagram

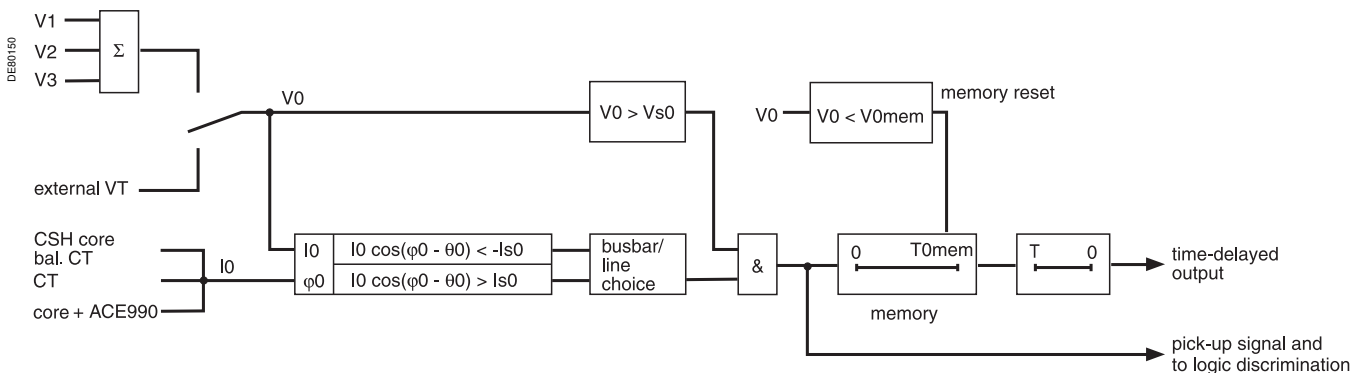

Definite time operation

I_{s0} is the operation set point expressed in Amps, and T is the protection operation time delay.

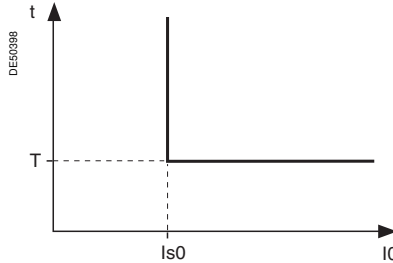

Definite time protection principle.

Memory

The detection of recurrent faults is controlled by the time delay T_{0mem} which extends the transient pick-up information, thereby enabling the operation of the definite time delay even with faults that are rapidly extinguished (≈ 2 ms) and restrike periodically.

Even when a Petersen coil with no additional resistance is used, tripping is ensured by fault detection during the transient fault appearance, with detection extended throughout the duration of the fault based on the $V_0 \geq V_{0mem}$ criterion, within the limit of T_{0mem} . With this type of application, T_{0mem} must be greater than T (definite time delay).

Standard setting

The settings below are given for usual applications in the different earthing systems. The shaded boxes represent default settings.

	Isolated neutral	Impedant neutral	Compensated neutral
I_{s0} set point	To be set according to network coordination study	To be set according to network coordination study	To be set according to network coordination study
Characteristic angle θ_0	90°	0°	0°
Time delay T	To be set according to network coordination study	To be set according to network coordination study	To be set according to network coordination study
Direction	Line	Line	Line
V_{s0} setpoint	2 % of U_{ns}	2 % of U_{ns}	2 % of U_{ns}
Sector	N/A	86°	86°
Memory time T_{0mem}	0	0	200 ms
Memory voltage V_{0mem}	0	0	0

Characteristics - Type 1

Measurement origin	
Setting range	10
Characteristic angle $\theta 0$	
Setting	-45°, 0°, 15°, 30°, 45°, 60°, 90°
Accuracy	±3°
Tripping direction	
Setting	Busbar / line
Is0 set point	
Setting ⁽¹⁾	0.1 In0 ≤ Is0 ≤ 15 In0 ⁽¹⁾ expressed in Amps
	With CSH sensor
2 A rating	0.2 A ≤ Is0 ≤ 30 A
5 A rating	0.5 A ≤ Is0 ≤ 75 A
20 A rating	2 A ≤ Is0 ≤ 300 A
CT ⁽¹⁾	0.1 In0 ≤ Is0 ≤ 15 In0 (min. 0.1 A)
Core balance CT with ACE990	0.1 In0 ≤ Is0 ≤ 15 In0
Resolution	0.1 A or 1 digit
Accuracy at $\varphi 0 = 180^\circ + \theta 0$	±5 % or ±0.01 In0
Drop out/pick-up ratio	> 89 % or > (1 - 0.015 In0/Is0) x 100 %
Vs0 set point	
Setting	2 % Unp to 80 % Unp
Resolution	1 %
Accuracy at $\varphi 0 = 180^\circ + \theta 0$	±5 %
Drop out/pick-up ratio	> 89 %
Sector	
Setting	86°; 83°; 76°
Accuracy	With CCA634 ± 2°
	With CT + CSH30 ± 3°
Time delay T	
Setting	inst., 0.05 s ≤ T ≤ 300 s
Resolution	10 ms or 1 digit
Accuracy	≤ 2 % or -10 ms to +25 ms
Memory time T0mem	
Setting	0,05 s ≤ T0mem ≤ 300 s
Resolution	10 ms or 1 digit
Memory voltage V0mem	
Setting	0; 2 % Unp ≤ V0mem ≤ 80 % Unp
Resolution	1 %
Characteristic times	
Operation time	Pick-up < 45 ms Confirmed instantaneous: ■ inst. < 50 ms at 2 Is0 for Is0 ≥ 0.3 In0 (typically 35 ms) ■ inst. < 70 ms at 2 Is0 for Is0 < 0.3 In0 (typically 50 ms)
Overshoot time	< 35 ms
Reset time	< 35 ms (at T0mem = 0)

(1) In0 = sensor rating if the measurement is taken by a CSH120, CSH200 or CSH300 core balance CT. In0 = In of the CT if the measurement is taken by a 1 A or 5 A current transformer. In0 = In of the CT /10 if the measurement is taken by a 1 A or 5 A current transformer with the sensitivity x 10 option.

TS/TC equivalence for each protocol

Modbus	DNP3	IEC 60870-5-103	IEC 61850
TC AcXVi	Binary Output	ASDU, FUN, INF	LN.DO.DA
TC3	BO08	20, 160, 23	LLN0.SGCB.SetActiveSettingGroup
TC4	BO09	20, 160, 24	LLN0.SGCB.SetActiveSettingGroup

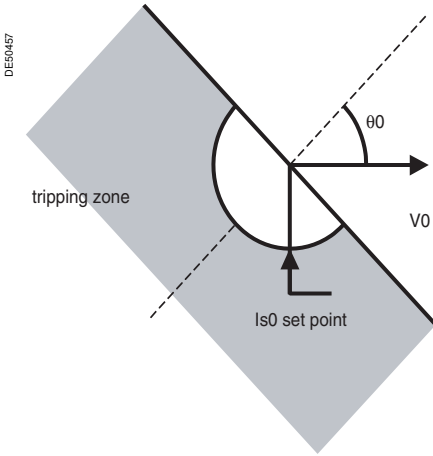

Tripping characteristic of protection 67N, type 2.

Type 2 operation

The protection function operates like an earth fault protection function with an added direction criterion.

It is suitable for closed ring distribution networks with directly earthed neutral. It has all the characteristics of an earth fault protection function (50N/51N) and can therefore be easily coordinated with that function.

The residual current is the current measured at the Sepam I0 input or calculated using the sum of the phase currents, according to the parameter setting.

The time delay may be definite time (DT) or IDMT according to the curves below. The protection function includes a timer hold delay T1 for the detection of restriking faults.

The tripping direction may be set at the busbar end or line end.

Definite time protection

Is0 is the operation set point expressed in Amps, and T is the protection operation time delay.

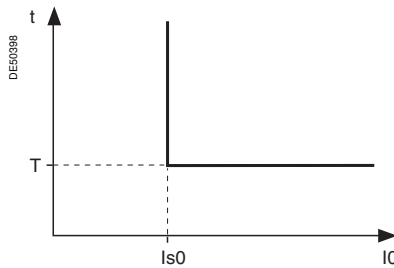

IDMT protection

The IDMT protection function operates in accordance with the IEC 60255-3, BS 142 and IEEE C-37112 standards.

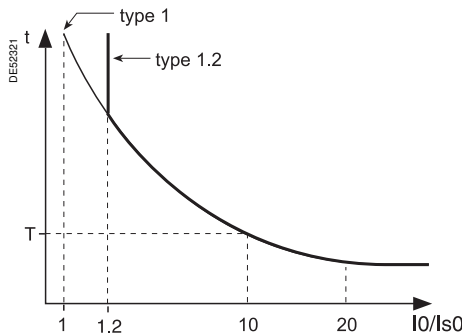

The Is setting is the vertical asymptote of the curve, and T is the operation time delay for 10 Is0.

The tripping time for I0/Is0 values of less than 1.2 depends on the type of curve chosen.

Name of curve	Type
Standard inverse time (SIT)	1.2
Very inverse time (VIT or LTI)	1.2
Extremely inverse time (EIT)	1.2
Ultra inverse time (UIT)	1.2
RI curve	1
IEC temps inverse SIT / A	1
IEC very inverse time VIT or LTI / B	1
IEC extremely inverse time EIT / C	1
IEEE moderately inverse (IEC / D)	1
IEEE very inverse (IEC / E)	1
IEEE extremely inverse (IEC / F)	1
IAC inverse	1
IAC very inverse	1
IAC extremely inverse	1

The curve equations are given in the chapter entitled "IDMT protection functions".

Block diagram

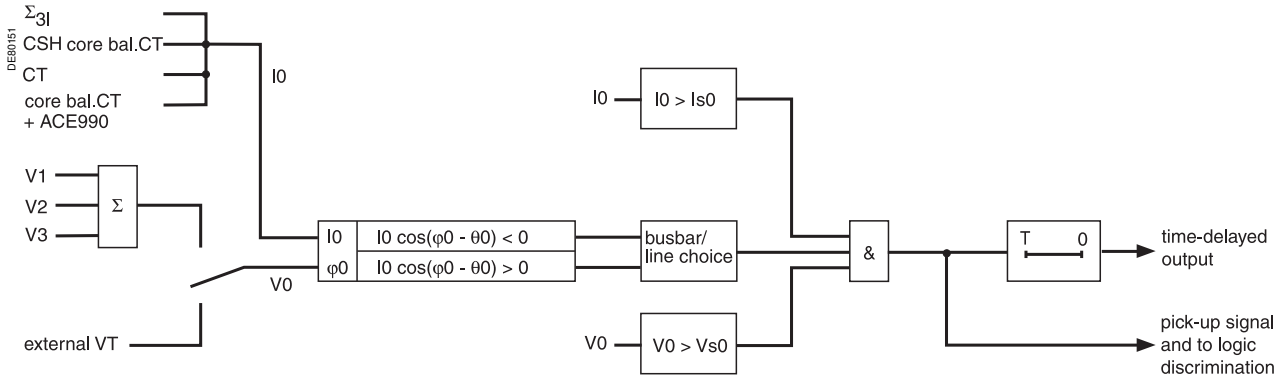

Timer hold delay

The function includes an adjustable timer hold delay T1:

- definite time (timer hold) for all the tripping curves.

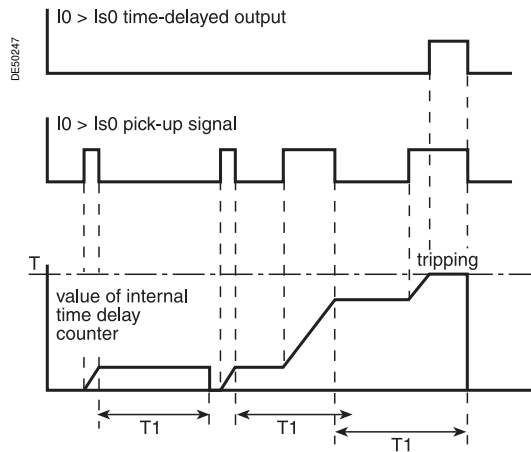

- IDMT for IEC, IEEE and IAC curves.

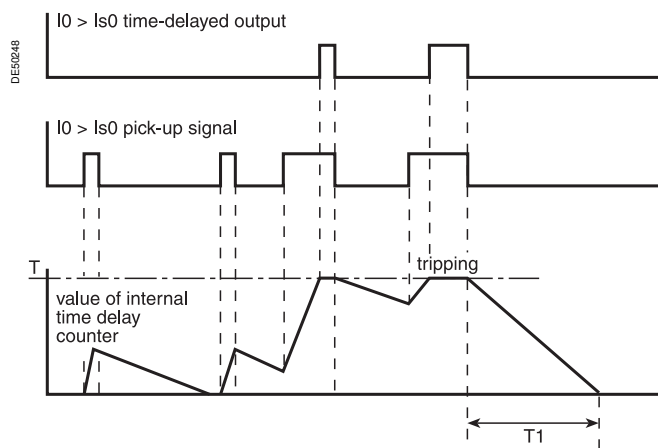

Characteristics - Type 2

Measurement origin	
Setting range	10 10Σ
Characteristic angle θ0	
Setting	-45°, 0°, 15°, 30°, 45°, 60°, 90°
Accuracy	±3°
Tripping direction	
Setting	Busbar / line
Is0 setting	
Definite time setting	0.1 In0 ≤ Is0 ≤ 15 In0 ⁽¹⁾ expressed in Amps
	Sum of CTs 0.1 In0 ≤ Is0 ≤ 15 In0
	With CSH sensor
2 A rating	0.2 A to 30 A
5 A rating	0.5 A to 75 A
20 A rating	2 A to 300 A
CT	0.1 In0 ≤ Is0 ≤ 15 In0 (min. 0.1 A)
Core balance CT with ACE990	0.1 In0 < Is0 < 15 In0
IDMT setting	0.1 In0 ≤ Is0 ≤ In0 ⁽¹⁾ expressed in Amps
	Sum of CTs 0.1 In0 ≤ Is0 ≤ In0
	With CSH sensor
2 A rating	0.2 A to 2 A
5 A rating	0.5 A to 5 A
20 A rating	2 A to 20 A
CT	0.1 In0 ≤ Is0 ≤ 1 In0 (min. 0.1 A)
Core balance CT with ACE990	0.1 In0 ≤ Is0 ≤ In0
Resolution	0.1 A or 1 digit
Accuracy ⁽²⁾	±5 % or ±0.01 In0
Drop out/pick-up ratio	93.5 % ±5 % (with CSH sensor, CT or core balance CT + ACE990) 93.5 % ±5 % or > (1 - 0.015 In0/Is0) x 100 % (sum of CTs)
Vs0 set point	
Setting	2 % Un to 80 % Un
Resolution	1 %
Accuracy	±5 %
Drop out/pick-up ratio	93.5 % ±5 %
Time delay T (operation time at 10 Is0)	
Setting	definite time inst., 50 ms ≤ T ≤ 300 s
	IDMT 100 ms ≤ T ≤ 12.5 s or TMS ⁽³⁾
Resolution	10 ms or 1 digit
Accuracy ⁽²⁾	definite time 2 % or -10 ms to +25 ms
	IDMT Class 5 or from -10 to +25 ms
Timer hold delay T1	
Definite time (timer hold)	0; 50 ms ≤ T1 ≤ 300 s
IDMT ⁽⁴⁾	0.5 s ≤ T1 ≤ 20 s
Characteristic times	
Operation time	Pick-up < 40 ms at 2 Is0 (typically 25 ms) Confirmed instantaneous: ■ inst. < 50 ms at 2 Is0 for Is0 ≥ 0.3 In0 (typically 35 ms) ■ inst. < 70 ms at 2 Is0 for Is0 < 0.3 In0 (typically 50 ms)
Overshoot time	< 35 ms
Reset time	< 40 ms (for T1 = 0)

(1) In0 = In if the sum of the three phase currents is used for the measurement.
In0 = sensor rating if the measurement is taken by a CSH120, CSH200 or CSH300 core balance CT.
In0 = In of the CT if the measurement is taken by a 1 A or 5 A current transformer .
In0 = In of the CT /10 if the measurement is taken by a 1 A or 5 A current transformer with the sensitivity x 10 option.

(2) In reference conditions (IEC 60255-6).

(3) Setting ranges in TMS (Time Multiplier Setting) mode
Inverse (SIT) and IEC SIT/A: 0.04 to 4.20
Very inverse (VIT) and IEC VIT/B:0.07 to 8.33
Very inverse (LTI) and IEC LTI/B:0.01 to 0.93
Ext inverse (EIT) and IEC EIT/C: 0.13 to 15.47
IEEE moderately inverse:0.42 to 51.86
IEEE very inverse: 0.73 to 90.57
IEEE extremely inverse: 1.24 to 154.32
IAC inverse: 0.34 to 42.08
IAC very inverse: 0.61 to 75.75
IAC extremely inverse:1.08 to 134.4

(4) Only for standardized tripping curves of the IEC, IEEE and IAC types.

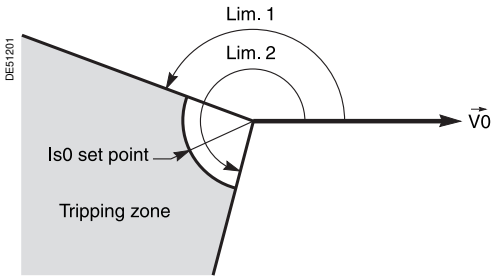

Type 3 operation

The protection function operates like an earth fault protection function with an added angular direction criterion (*Lim. 1*, *Lim. 2*). It is adapted for distribution networks in which the neutral earthing system varies according to the operating mode. The tripping direction may be set at the busbar end or line end. The residual current is the current measured at the Sepam I0 input. The time delay may be definite time (DT). In choosing an Is0 setting equal to zero, the protection is equivalent to the neutral voltage displacement protection (ANSI 59N).

Block diagram

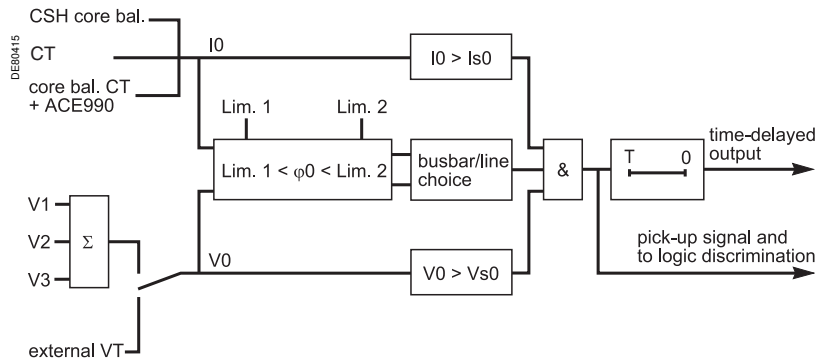

Definite time operation

Is0 is the operation set point expressed in Amps, and T is the protection operation time delay

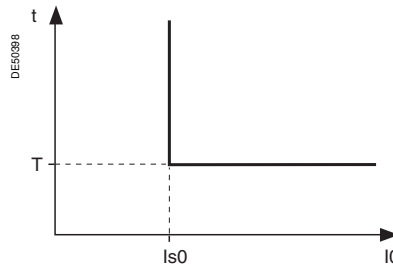

Definite time protection principle.

Characteristics - Type 3

Measurement origin	
Setting range	I0
Angle at start of tripping zone Lim.1	
Setting	0° to 359°
Resolution	1°
Accuracy	±3°
Angle at end of tripping zone Lim.2	
Setting	0° to 359° (1)
Resolution	1°
Accuracy	±3°
Tripping direction	
Setting	Busbar / line
Is0 setting	
Setting (2)	With CSH core balance CT 2 A rating: 0.1 A to 30 A 20 A rating: 2 A to 300 A
	With sensitive 1 A CT 0.05 In0 ≤ Is0 ≤ 15 In0 (minimum 0.1 A)
	With core balance CT + ACE990 (range 1) 0.05 In0 ≤ Is0 ≤ 15 In0 (minimum 0.1 A) (3)
Resolution	0.1 A or 1 digit
Accuracy	±5 %
Drop out/pick-up ratio	≥ 90 %
Vs0 set point	
Setting	Calculated V0 (sum of 3 voltages) 2 % Unp ≤ Vs0 ≤ 80 % Unp
	Measured V0 (external VT) 0.6 % Unp ≤ Vs0 ≤ 80 % Unp
Resolution	0.1 % for Vs0 < 10 % 1 % for Vs0 ≥ 10 %
Accuracy	±5 %
Drop out/pick-up ratio	≥ 90 %
Time delay T	
Setting	Instantaneous, 50 ms ≤ T ≤ 300 s
Resolution	10 ms or 1 digit
Accuracy	≤ 3 % or ±20 ms at 2 Is0
Characteristics times	
Operation time	Pick-up < 40 ms at 2 Is0 Instantaneous < 50 ms at 2 Is0
Overshoot time	< 35 ms to 2 Is0
Reset time	< 50 ms to 2 Is0

(1) The tripping zone Lim.2-Lim.1 must be greater than or equal to 10°.

(2) For Is0 = 0, the protection is equivalent to the neutral voltage displacement protection (ANSI 59N).

(3) In0 = k · n

with n = number of core balance CT turns

and k = factor to be determined according to the wiring of the ACE990 (0.00578 ≤ k ≤ 0.04).

Standard settings for tripping zone

The settings below are given for usual applications in the different earthing systems. The shaded boxes represent default settings.

	Isolated neutral	Impedant neutral	Directly earthed neutral
Angle Lim.1	190°	100°	100°
Angle Lim.2	350°	280°	280°

Definition

Reclaim time

The reclaim time delay is activated by a circuit breaker closing order given by the recloser.

If no faults are detected before the end of the reclaim time delay, the initial fault is considered to have been cleared.

Otherwise a new reclosing cycle is initiated.

Safety time until recloser ready

After manual closing of the circuit breaker, the recloser function is inhibited during this time. If a fault occurs during this time, no reclosing cycles are initiated and the circuit breaker remains permanently open.

Dead time

The cycle n dead time delay is activated by the circuit breaker tripping order given by the recloser in cycle n. The breaking device remains open throughout the time delay.

At the end of the cycle n dead time delay, the n+1 cycle begins, and the recloser orders the closing of the circuit breaker.

Operation

Initialization of the recloser

The recloser is ready to operate if all of the following conditions are met:

- "CB control" function activated and recloser in service
- circuit breaker closed
- safety time until 79 ready elapsed
- none of the recloser inhibition conditions is true (see further on).

The "recloser ready" information may be viewed with the control matrix.

Recloser cycles

- case of a cleared fault:

□ following a reclosing order, if the fault does not appear after the reclaim time has run out, the recloser reinitializes and a message appears on the display (see example 1).

- case of a fault that is not cleared:

□ following instantaneous or time-delayed tripping by the protection unit, activation of the dead time associated with the first active cycle.

At the end of the dead time, a closing order is given, which activates the reclaim time.

If the protection unit detects the fault before the end of the time delay, a tripping order is given and the following reclosing cycle is activated.

□ after all the active cycles have been run, if the fault still persists, a final trip order is given, a message appears on the display and closing is locked out until acknowledgment takes place, according to the parameter setting of the protection function.

- closing on a fault.

If the circuit breaker closes on a fault, or if the fault appears before the end of the safety time delay, the recloser is inhibited.

Recloser inhibition conditions

The recloser is inhibited according to the following conditions:

- voluntary open or close order
- recloser put out of service
- receipt of a inhibition order on the logic input
- activation of the breaker failure function (50BF)
- appearance of a switchgear-related fault, such as trip circuit fault, control fault, SF6 pressure drop
- opening of the circuit breaker by a protection unit that does not run reclosing cycles (e.g. frequency protection) or by external tripping. In such cases, a final trip message appears.

Extension of the dead time

If, during a reclosing cycle, reclosing of the circuit breaker is impossible because breaker recharging is not finished (following a drop in auxiliary voltage, recharging time is longer), the dead time may be extended up to the time at which the circuit breaker is ready to carry out an "Open-Close-Open" cycle. The maximum time added to the dead time is adjustable (T_{wait_max}). If, at the end of the maximum waiting time, the circuit breaker is still not ready, the recloser is inhibited (see example 4, 5).

Characteristics

Reclosing cycles		Setting
Number of cycles		1 to 4
Activation of cycle 1 ⁽¹⁾	max I 1 to 4	inst. / delayed / no activation
	max IO 1 to 4	inst. / delayed / no activation
	directional max I 1 to 2	inst. / delayed / no activation
	directional max IO 1 to 2	inst. / delayed / no activation
	V_TRIPCB output (logic equation)	activation / no activation
Activation of cycles 2, 3 and 4 ⁽¹⁾	max I 1 to 4	inst. / delayed / no activation
	max IO 1 to 4	inst. / delayed / no activation
	directional max I 1 to 2	inst. / delayed / no activation
	directional max IO 1 to 2	inst. / delayed / no activation
	V_TRIPCB output (logic equation)	activation / no activation
Time delays		
Reclaim time		0.1 to 300 s
Dead time	cycle 1	0.1 to 300 s
	cycle 2	0.1 to 300 s
	cycle 3	0.1 to 300 s
	cycle 4	0.1 to 300 s
Safety time until 79 ready		0 to 60 s
Maximum additional dead time (T_{wait_max})		0.1 to 60 s
Accuracy		±2 % or 25 ms
Resolution		10 ms or 1 digit

(1) If a protection function that does not activate reclosing cycles leads to circuit breaker opening, the recloser is inhibited.

Example 1: fault cleared after the second cycle

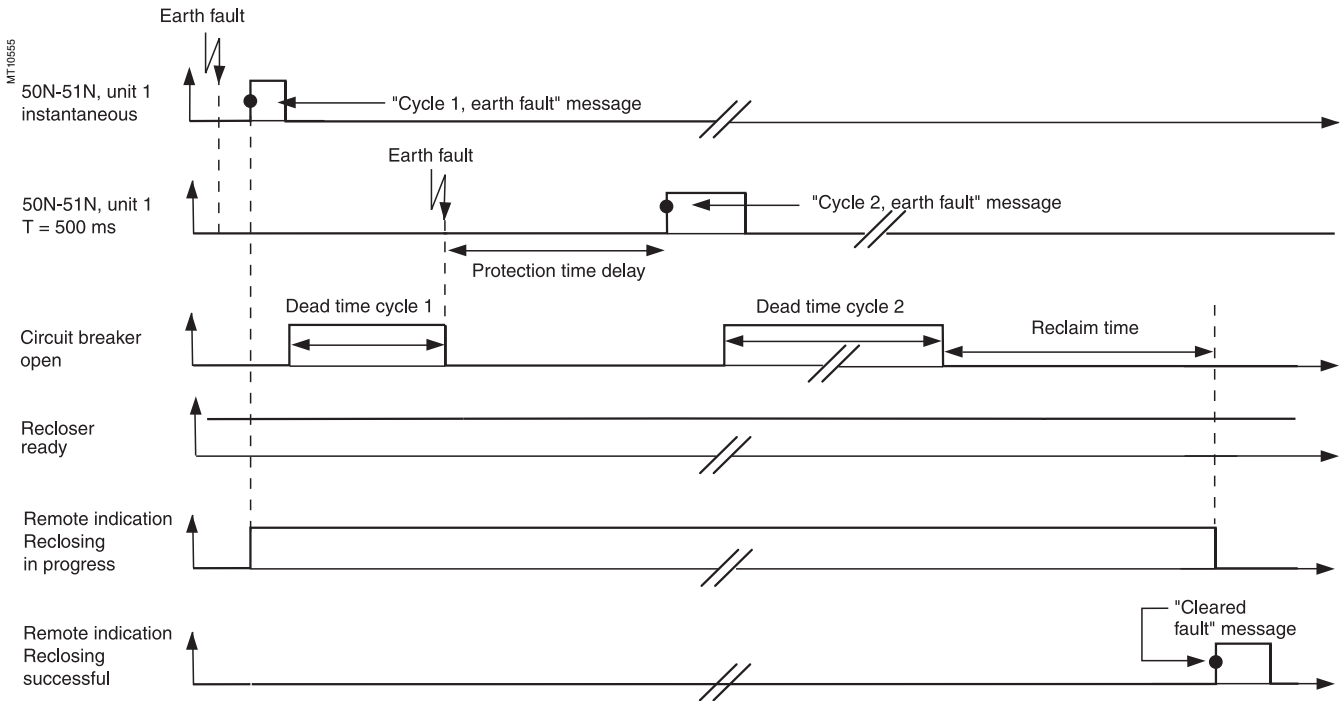

Example 2: fault not cleared

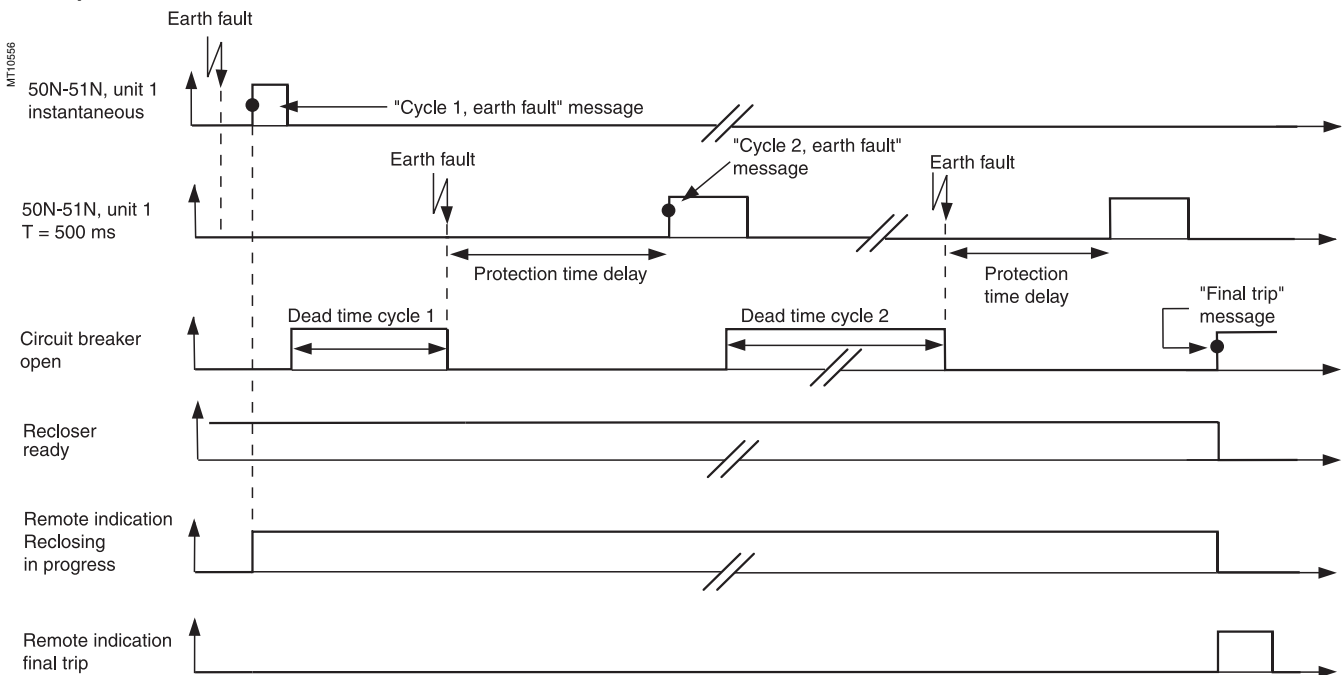

3

Example 3: closing on a fault

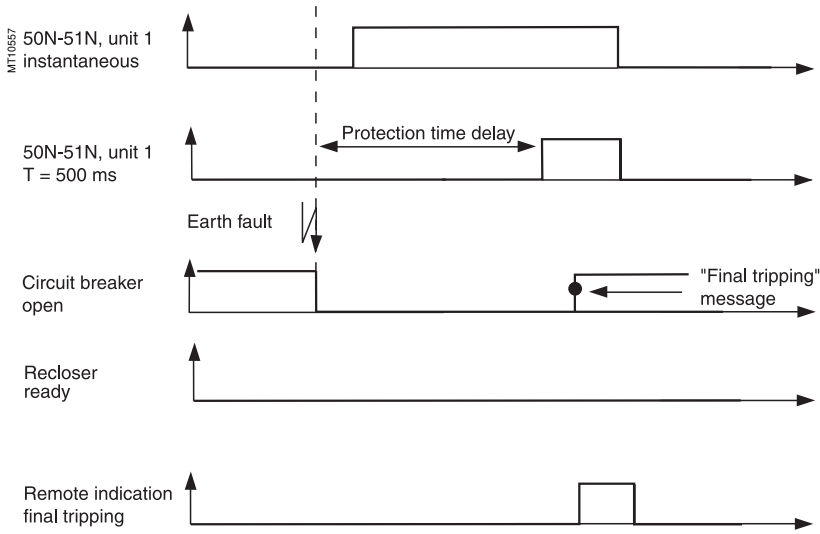

Example 4: no extension of dead time

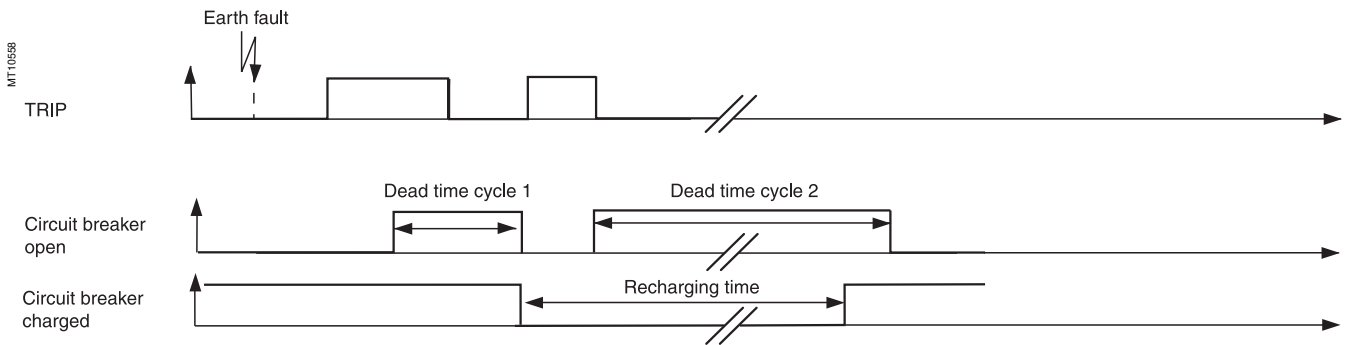

Example 5: extension of dead time

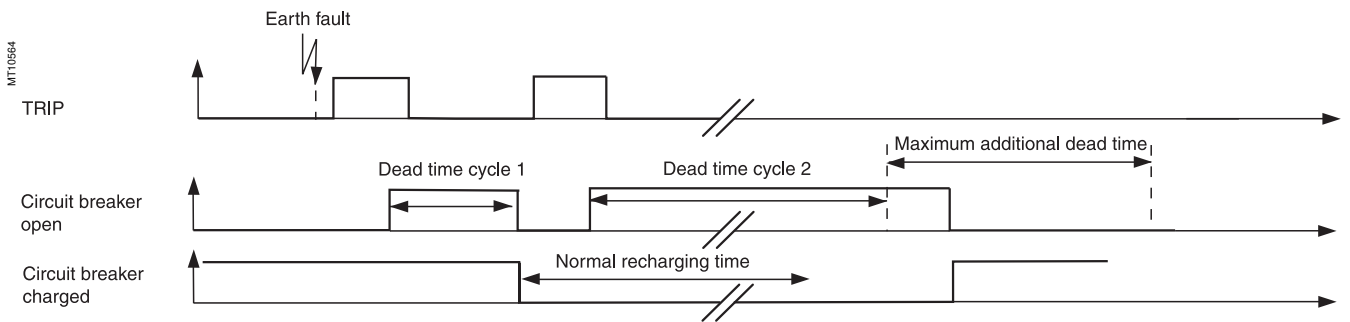

Operation

The protection function picks up when the positive sequence voltage frequency is above the F_s set point and the positive sequence voltage is above the V_s set point. If a single VT is connected (U21), the function picks up when the frequency is above the F_s set point and the U21 voltage is above the V_s set point. It includes a definite time delay T.

Block diagram

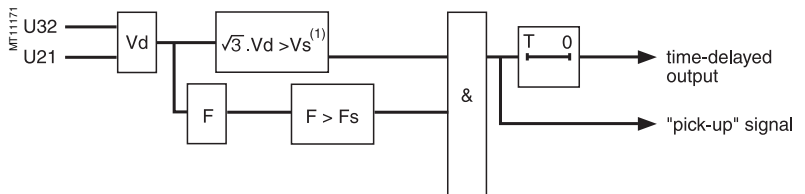

(1) Or $U_{21} > V_s$ if only one VT.

Characteristics

Fs set point	
Setting	50 to 55 Hz or 60 to 65 Hz
Accuracy (1)	±0.02 Hz
Resolution	0.1 Hz
Pick up / drop out difference	0.25 Hz ±0.1 Hz
Vs set point	
Setting	20 % Unp to 50 % Unp
Accuracy (1)	±2 %
Resolution	1 %
Time delay T	
Setting	100 ms to 300 s
Accuracy (1)	±2 % or ±25 ms
Resolution	10 ms or 1 digit
Characteristic times (1)	
Operation time	pick-up < 80 ms
Overshoot time	< 40 ms
Reset time	< 50 ms

(1) In reference conditions (IEC 60255-6) and $df/dt < 3$ Hz/s.

Operation

The function picks up when the positive sequence voltage frequency is below the F_s set point and if the positive sequence voltage is above the V_s set point. If a single VT is connected (U21), the function picks up when the frequency is below the F_s set point and the U21 voltage is above the V_s set point. It includes a definite time delay T.

The protection function includes a restraint which may be configured according to the rate of change of frequency which inhibits the protection in the event of a continuous decrease in frequency greater than the inhibition set point. This setting avoids the tripping of all the feeders when the busbar is resupplied by remanent motor voltage following the loss of the incomer.

Block diagram

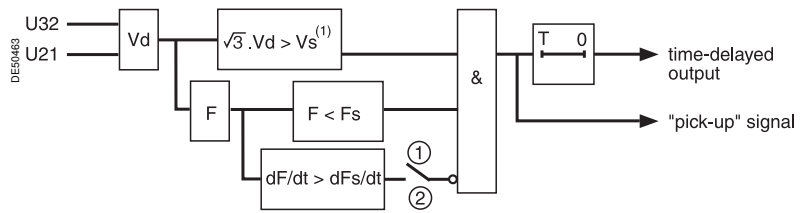

setting: ① without restraint
② with restraint

(1) Or $U_{21} > V_s$ if only one VT.

Characteristics

Fs set point	
Setting	40 to 50 Hz or 50 to 60 Hz
Accuracy ⁽¹⁾	±0.02 Hz
Resolution	0.1 Hz
Pick-up / drop out difference	0.25 Hz ±0.1 Hz
Vs set point	
Setting	20 % Unp to 50 % Unp
Accuracy ⁽¹⁾	2 %
Resolution	1 %
Restraint on frequency variation	
Setting	With / without
dFs/dt set point	1 Hz/s to 15 Hz/s
Accuracy ⁽¹⁾	1 Hz/s
Resolution	1 Hz/s
Time delay T	
Setting	100 ms to 300 s
Accuracy ⁽¹⁾	±2 % or ±25 ms
Resolution	10 ms or 1 digit
Characteristic times ⁽¹⁾	
Operation time	pick-up < 80 ms
Overshoot time	< 40 ms
Reset time	< 50 ms

(1) In reference conditions (IEC 60255-6) and $df/dt < 3$ Hz/s.

Presentation of tripping curve operation and settings for protection functions using:

- definite time
- IDMT
- timer hold.

Definite time protection

The tripping time is constant. The time delay is started when the set point is overrun.

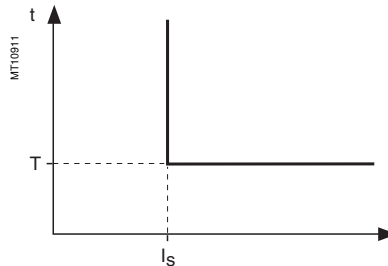

Definite time protection principle.

IDMT protection

The operation time depends on the protected value (phase current, earth fault current, etc.) in accordance with standards IEC 60255-3, BS 142 and IEEE C37.112.

Operation is represented by a characteristic curve, e.g.:

- $t = f(I)$ curve for the **phase overcurrent** function
- $t = f(I_0)$ curve for the **earth fault** function.

The rest of the document is based on $t = f(I)$; the reasoning may be extended to other variables I_0 , etc.

The curve is defined by:

- its type (standard inverse, very inverse, extremely inverse, etc.)
- current setting I_s which corresponds to the vertical asymptote of the curve
- time delay T which corresponds to the operation time for $I = 10 I_s$.

These 3 settings are made chronologically in the following order: type, I_s current, time delay T .

Changing the time delay T setting by $x\%$ changes all of the operation times in the curve by $x\%$.

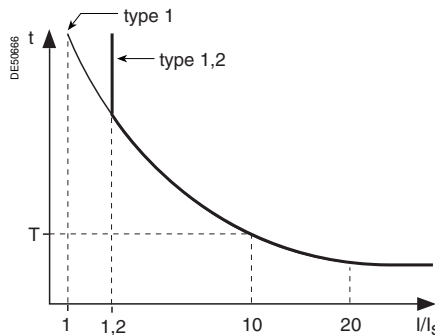

IDMT protection principle.

The tripping time for I/I_s values less than 1.2 depends on the type of curve selected.

Name of curve	Type
Standard inverse time (SIT)	1, 2
Very inverse time (VIT or LTI)	1, 2
Extremely inverse time (EIT)	1, 2
Ultra inverse time (UIT)	1, 2
RI curve	1
IEC inverse time SIT / A	1
IEC very inverse time VIT or LTI / B	1
IEC extremely inverse time EIT / C	1
IEEE moderately inverse (IEC / D)	1
IEEE very inverse (IEC / E)	1
IEEE extremely inverse (IEC / F)	1
IAC inverse	1
IAC very inverse	1
IAC extremely inverse	1

■ when the monitored value is more than 20 times the set point, the tripping time is limited to the value corresponding to 20 times the set point.

■ if the monitored value exceeds the measurement capacity of Sepam (40 In for the phase current channels, 20 In0 for the residual current channels), the tripping time is limited to the value corresponding to the largest measurable value (40 In or 20 In0).

Current IDMT tripping curves

Multiple IDMT tripping curves are offered, to cover most applications:

- IEC curves (SIT, VIT/LTI, EIT)
- IEEE curves (MI, VI, EI)
- commonly used curves (UIT, RI, IAC).

IEC curves

Equation	Curve type	Coefficient values		
		k	α	β
$t_d(I) = \frac{k}{\left(\frac{I}{I_s}\right)^\alpha - 1} \times \frac{T}{\beta}$	Standard inverse / A	0.14	0.02	2.97
	Very inverse / B	13.5	1	1.50
	Long time inverse / C	120	1	13.33
	Extremely inverse / C	80	2	0.808
	Ultra inverse	315.2	2.5	1

RI curve

Equation:
$$t_d(I) = \frac{1}{0.339 - 0.236\left(\frac{I}{I_s}\right)^{-1}} \times \frac{T}{3.1706}$$

IEEE curves

Equation	Curve type	Coefficient values			
		A	B	p	β
$t_d(I) = \left(\frac{A}{\left(\frac{I}{I_s}\right)^p - 1} + B \right) \times \frac{T}{\beta}$	Moderately inverse	0.010	0.023	0.02	0.241
	Very inverse	3.922	0.098	2	0.138
	Extremely inverse	5.64	0.0243	2	0.081

IAC curves

Equation	Curve type	Coefficient values					
		A	B	C	D	E	β
$t_d(I) = \left(A + \frac{B}{\left(\frac{I}{I_s} - C\right)} + \frac{D}{\left(\frac{I}{I_s} - C\right)^2} + \frac{E}{\left(\frac{I}{I_s} - C\right)^3} \right) \times \frac{T}{\beta}$	Inverse	0.208	0.863	0.800	-0.418	0.195	0.297
	Very inverse	0.090	0.795	0.100	-1.288	7.958	0.165
	Extremely inverse	0.004	0.638	0.620	1.787	0.246	0.092

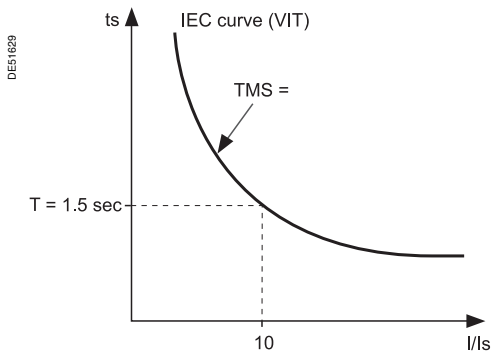

Setting of IDMT tripping curves, time delay T or TMS factor

The time delays of current IDMT tripping curves (except for customized and RI curves) may be set as follows:

- time T, operating time at 10 x Is
- TMS factor, factor shown as T/β in the equations on the left.

Example: $t(I) = \frac{13.5}{\frac{I}{I_s} - 1} \times TMS$ where $TMS = \frac{T}{1.5}$.

The IEC curve of the VIT type is positioned so as to be the same with TMS = 1 or T = 1.5 s.

Example.

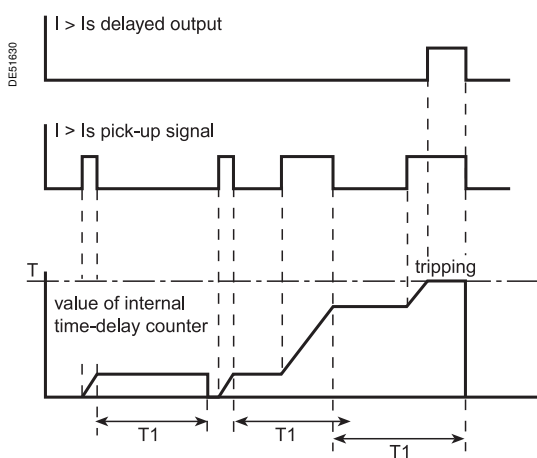

Timer hold

The adjustable timer hold T1 is used for:

- detection of restriking faults (DT curve)
- coordination with electromechanical relays (IDMT curve).
- Timer hold may be inhibited if necessary.

Equation for IDMT timer hold curve

Equation: $t_r(I) = \frac{T1}{1 - (\frac{I}{I_s})^2} \times \frac{T}{\beta}$ where $\frac{T}{\beta} = TMS$.

T1 = timer hold setting (timer hold for I reset = 0 and TMS = 1)

T = tripping time delay setting (at 10 Is)

b = basic tripping curve value at $\frac{k}{10^a - 1}$.

Detection of restriking faults with adjustable timer hold.

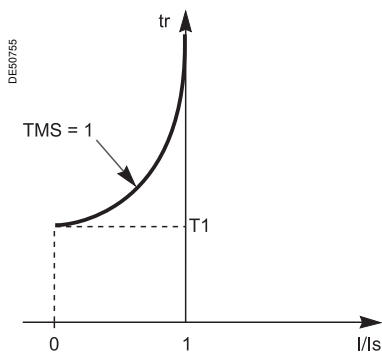

Timer hold dependent on current I.

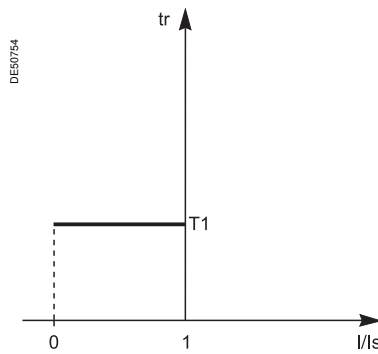

Constant timer hold.

Implementing IDMT curves: examples of problems to be solved.

Problem 1.

Given the type of IDMT, determine the I_s current and time delay T settings.

Theoretically, the I_s current setting corresponds to the maximum continuous current: it is generally the rated current of the protected equipment (cable, transformer).

The time delay T corresponds to operation at $10 I_s$ on the curve. This setting is determined taking into account the constraints involved in discrimination with the upstream and downstream protection devices.

The discrimination constraint leads to the definition of point A on the operation curve (I_A, t_A), e.g. the point that corresponds to the maximum fault current for the downstream protection device.

Problem 2.

Given the type of IDMT, the I_s current setting and a point $k (I_k, t_k)$ on the operation curve, determine the time delay setting T .

On the standard curve of the same type, read the operation time t_{sk} that corresponds to the relative current I_k/I_s and the operation time T_{s10} that corresponds to the relative current $I/I_s = 10$.

The time delay setting to be used so that the operation curve passes through the point $k (I_k, t_k)$ is:

$$T = T_{s10} \times \frac{t_k}{t_{sk}}$$

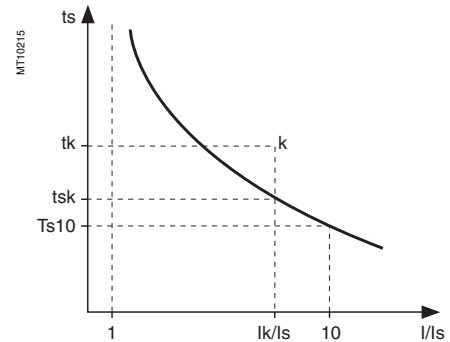

Another practical method:

the table below gives the values of $K = t_s/t_{s10}$ as a function of I/I_s .

In the column that corresponds to the type of time delay, read the value $K = t_{sk}/T_{s10}$ on the line for I_k/I_s .

The time delay setting to be used so that the operation curve passes through point $k (I_k, t_k)$ is: $T = t_k/k$.

Example

Data:

- type of time delay: standard inverse time (SIT)
- set point: I_s
- a point k on the operation curve: $k (3.5 I_s; 4 \text{ s})$

Question: What is the time delay T setting (operation time at $10 I_s$)?

Reading the table: **SIT** column, line $I/I_s = 3.5$ therefore $K = 1.858$

Answer: The time delay setting is $T = 4/1.858 = 2.15 \text{ s}$

Problem 3.

Given the I_s current and time delay T settings for a type of time delay (standard inverse, very inverse, extremely inverse), find the operation time for a current value I_A . On the standard curve of the same type, read the operation time t_A that corresponds to the relative current I_A/I_s and the operation time T_{s10} that corresponds to the relative current $I/I_s = 10$. The operation time t_A for the current I_A with the I_s and T settings is $t_A = t_A \times T/T_{s10}$.

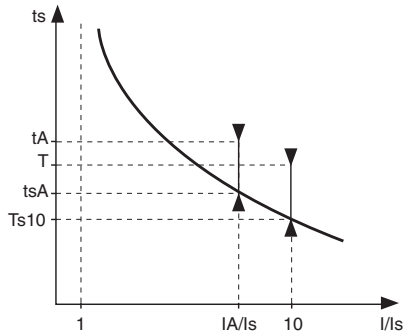

Another practical method:

the table below gives the values of $K = t_s/T_{s10}$ as a function of I/I_s . In the column that corresponds to the type of time delay, read the value $K = t_s/T_{s10}$ on the line for I_A/I_s , the operation time t_A for the current I_A with the I_s and T settings is $t_A = K \cdot T$.

Example

Data:

- type of time delay: very inverse time (VIT)
- set point: I_s
- time delay $T = 0.8$ s.

Question: What is the operation time for the current $I_A = 6 I_s$?

Reading the table: VIT column, line $I/I_s = 6$, therefore $k = 1.8$

Answer: The operation time for the current I_A is $t = 1.80 \times 0.8 = 1.44$ s.

Table of K values

I/I_s	SIT and IEC/A	VIT, LTI and IEC/B	EIT and IEC/C	UIT	RI	IEEE MI (IEC/D)	IEEE VI (IEC/E)	IEEE EI (IEC/F)	IAC I	IAC VI	IAC EI
1.0	—	—	—	—	3.062	—	—	—	62.005	62.272	200.226
1.1	24.700 ⁽¹⁾	90.000 ⁽¹⁾	471.429 ⁽¹⁾	—	2.534	22.461	136.228	330.606	19.033	45.678	122.172
1.2	12.901	45.000	225.000	545.905	2.216	11.777	65.390	157.946	9.413	34.628	82.899
1.5	5.788	18.000	79.200	179.548	1.736	5.336	23.479	55.791	3.891	17.539	36.687
2.0	3.376	9.000	33.000	67.691	1.427	3.152	10.199	23.421	2.524	7.932	16.178
2.5	2.548	6.000	18.857	35.490	1.290	2.402	6.133	13.512	2.056	4.676	9.566
3.0	2.121	4.500	12.375	21.608	1.212	2.016	4.270	8.970	1.792	3.249	6.541
3.5	1.858	3.600	8.800	14.382	1.161	1.777	3.242	6.465	1.617	2.509	4.872
4.0	1.676	3.000	6.600	10.169	1.126	1.613	2.610	4.924	1.491	2.076	3.839
4.5	1.543	2.571	5.143	7.513	1.101	1.492	2.191	3.903	1.396	1.800	3.146
5.0	1.441	2.250	4.125	5.742	1.081	1.399	1.898	3.190	1.321	1.610	2.653
5.5	1.359	2.000	3.385	4.507	1.065	1.325	1.686	2.671	1.261	1.473	2.288
6.0	1.292	1.800	2.829	3.616	1.053	1.264	1.526	2.281	1.211	1.370	2.007
6.5	1.236	1.636	2.400	2.954	1.042	1.213	1.402	1.981	1.170	1.289	1.786
7.0	1.188	1.500	2.063	2.450	1.033	1.170	1.305	1.744	1.135	1.224	1.607
7.5	1.146	1.385	1.792	2.060	1.026	1.132	1.228	1.555	1.105	1.171	1.460
8.0	1.110	1.286	1.571	1.751	1.019	1.099	1.164	1.400	1.078	1.126	1.337
8.5	1.078	1.200	1.390	1.504	1.013	1.070	1.112	1.273	1.055	1.087	1.233
9.0	1.049	1.125	1.238	1.303	1.008	1.044	1.068	1.166	1.035	1.054	1.144
9.5	1.023	1.059	1.109	1.137	1.004	1.021	1.031	1.077	1.016	1.026	1.067
10.0	1.000	1.000	1.000	1.000	1.000	1.000	1.000	1.000	1.000	1.000	1.000
10.5	0.979	0.947	0.906	0.885	0.996	0.981	0.973	0.934	0.985	0.977	0.941
11.0	0.959	0.900	0.825	0.787	0.993	0.963	0.950	0.877	0.972	0.957	0.888
11.5	0.941	0.857	0.754	0.704	0.990	0.947	0.929	0.828	0.960	0.939	0.841
12.0	0.925	0.818	0.692	0.633	0.988	0.932	0.912	0.784	0.949	0.922	0.799
12.5	0.910	0.783	0.638	0.572	0.985	0.918	0.896	0.746	0.938	0.907	0.761
13.0	0.895	0.750	0.589	0.518	0.983	0.905	0.882	0.712	0.929	0.893	0.727
13.5	0.882	0.720	0.546	0.471	0.981	0.893	0.870	0.682	0.920	0.880	0.695
14.0	0.870	0.692	0.508	0.430	0.979	0.882	0.858	0.655	0.912	0.868	0.667
14.5	0.858	0.667	0.473	0.394	0.977	0.871	0.849	0.631	0.905	0.857	0.641
15.0	0.847	0.643	0.442	0.362	0.976	0.861	0.840	0.609	0.898	0.846	0.616
15.5	0.836	0.621	0.414	0.334	0.974	0.852	0.831	0.589	0.891	0.837	0.594
16.0	0.827	0.600	0.388	0.308	0.973	0.843	0.824	0.571	0.885	0.828	0.573
16.5	0.817	0.581	0.365	0.285	0.971	0.834	0.817	0.555	0.879	0.819	0.554
17.0	0.808	0.563	0.344	0.265	0.970	0.826	0.811	0.540	0.874	0.811	0.536
17.5	0.800	0.545	0.324	0.246	0.969	0.819	0.806	0.527	0.869	0.804	0.519
18.0	0.792	0.529	0.307	0.229	0.968	0.812	0.801	0.514	0.864	0.797	0.504
18.5	0.784	0.514	0.290	0.214	0.967	0.805	0.796	0.503	0.860	0.790	0.489
19.0	0.777	0.500	0.275	0.200	0.966	0.798	0.792	0.492	0.855	0.784	0.475
19.5	0.770	0.486	0.261	0.188	0.965	0.792	0.788	0.482	0.851	0.778	0.463
20.0	0.763	0.474	0.248	0.176	0.964	0.786	0.784	0.473	0.848	0.772	0.450

(1) Values only suitable for IEC A, B and C curves.

3

Standard inverse time (SIT) curve
Very inverse time (VIT or LTI) curve
RI curve

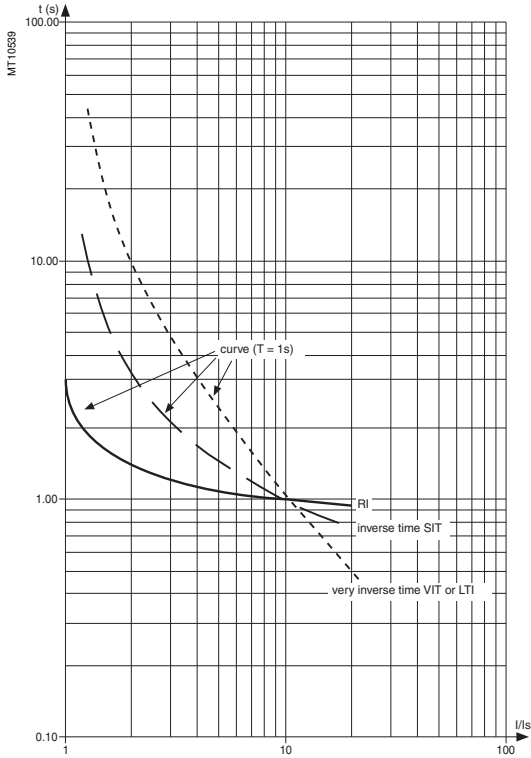

Extremely inverse time (EIT) curve
Ultra inverse time (UIT) curve

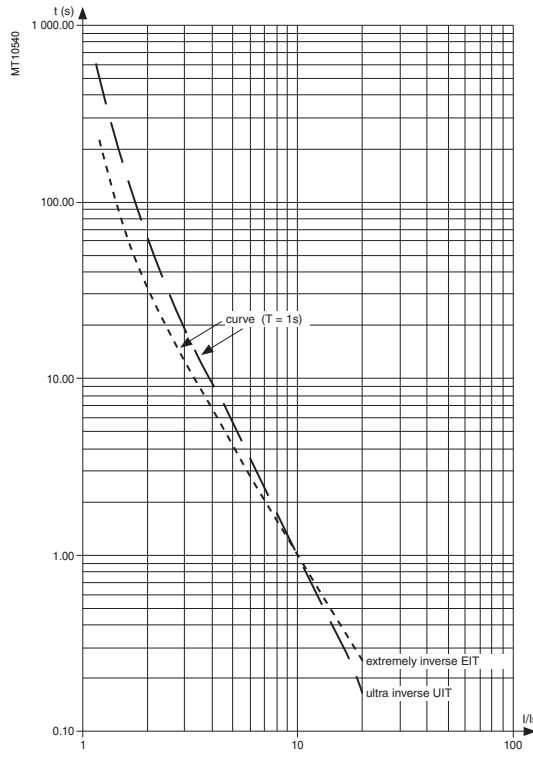

IEEE curves

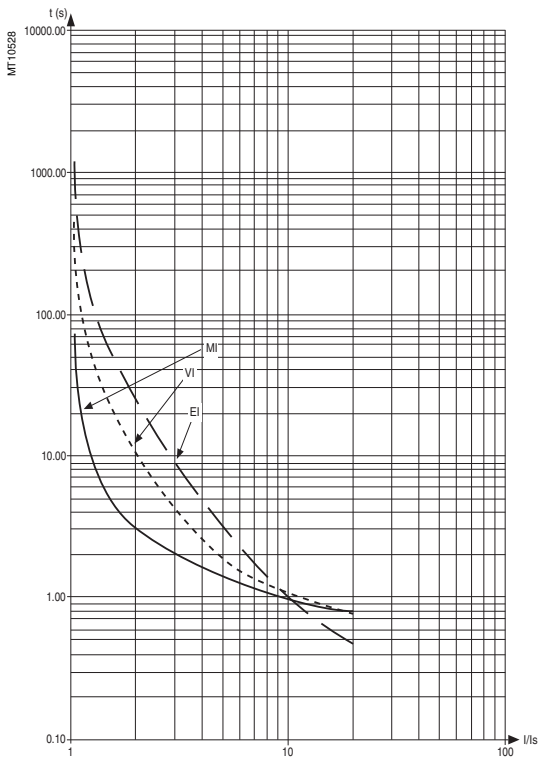

IAC curves

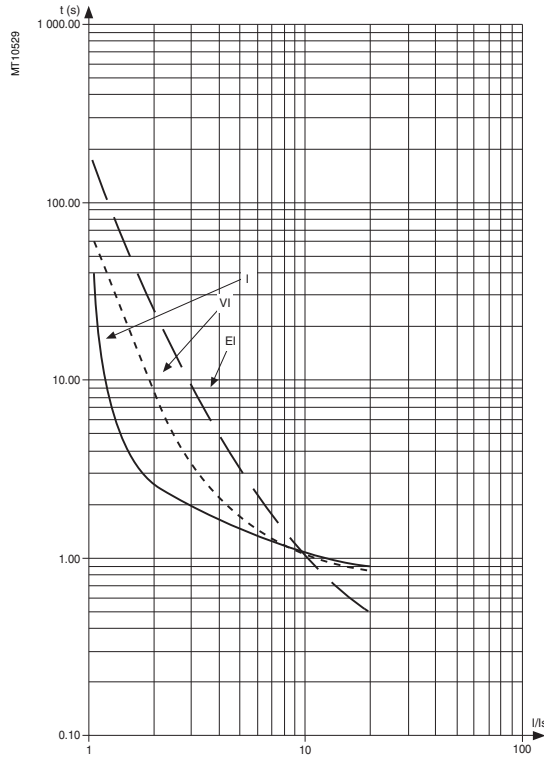

Description	112
Definition of symbols	113
Logic input / output assignment	114
Standard logic input assignment	115
Circuit breaker / contactor control ANSI code 94/69	116
Associated functions	118
Logic discrimination ANSI code 68	120
Radial network	120
Closed ring network	122
Substation with 2 parallel incomers	124
Disturbance recording triggering	125
Switching of groups of settings	126
Local indication ANSI code 30	127
Control matrix	129
Logic equations	130
Self-tests and fail-safe position	135

Sepam performs the control and monitoring functions required for electrical network operation:

- the main control and monitoring functions are predefined and fit the applications most frequently used. They are ready to use, and are implemented by simple parameter setting after the necessary logic inputs / outputs have been assigned.
- the predefined control and monitoring functions can be adapted for particular needs using the SFT2841 software, which offers the following customization options:
 - logic equation editor, to adapt and complete predefined control and monitoring functions
 - creation of user messages for local display
 - customization of the control matrix by changing the assignment of output relays, LEDs and display messages.

Operating principle

The processing of each control and monitoring function may be broken down into 3 phases:

- acquisition of input data:
 - results of protection function processing
 - external logic data, connected to the logic inputs of an optional MES120 input / output module
 - remote control orders (TC) received via the communication link
- actual logic processing of the control and monitoring function
- utilization of the processing results:
 - activation of output relays to trigger an actuator
 - information sent to the facility manager:
 - by message and/or LED on the advanced UMI and SFT2841 software
 - by remote indication (TS) via the communication link.

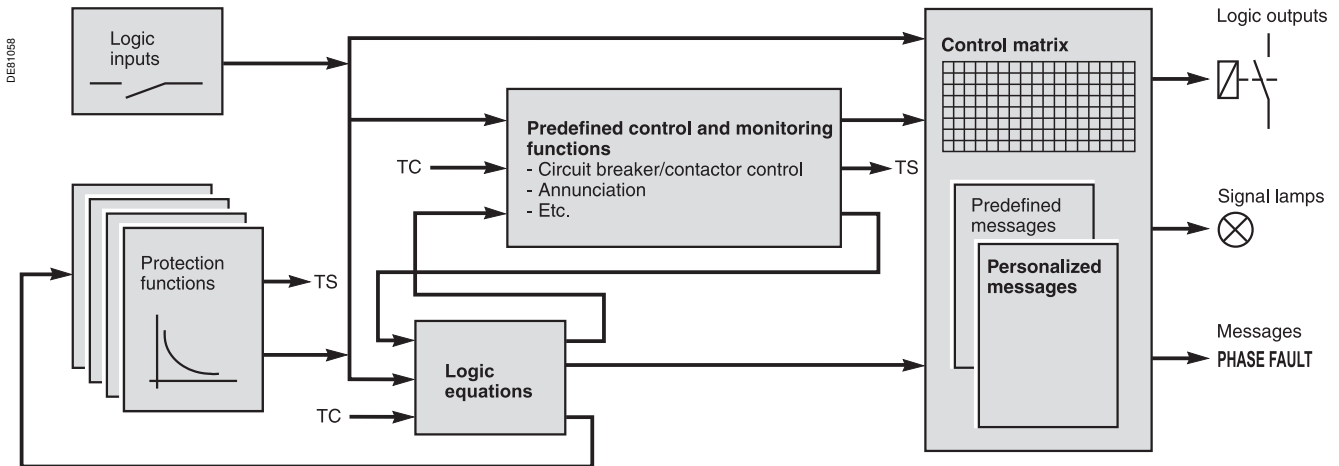

Logic inputs and outputs

The number of Sepam inputs / outputs is adapted to fit the control and monitoring functions used. The 4 outputs included in the Sepam series 40 base unit may be extended by adding one MES114 module with 10 logic inputs and 4 output relays. After selecting the MES114 type required by an application, the logic inputs must be assigned to functions. The functions to which inputs are assigned are chosen from a list of available functions which covers the whole range of possible uses. The functions used can be adapted to meet needs within the limits of the logic inputs available. The inputs may also be inverted for undervoltage type operation. A default input / output assignment is proposed for the most frequent uses.

This page gives the meaning of the symbols used in the block diagrams illustrating the different control and monitoring functions in this chapter.

Logic functions

■ "OR"

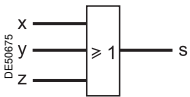

Equation: $S = X + Y + Z$.

■ "AND"

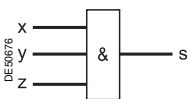

Equation: $S = X \times Y \times Z$.

■ exclusive "XOR"

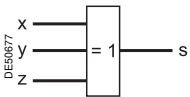

$S = 1$ if one and only one input is set to 1
($S = 1$ if $X + Y + Z = 1$).

■ Complement

These functions may use the complement of one or more input values.

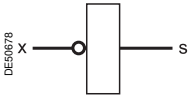

Equation: $S = \bar{X}$ ($S = 1$ if $X = 0$).

Delay timers

Two types of delay timers:

■ "on" delay timer: used to delay the appearance of a signal by a time T

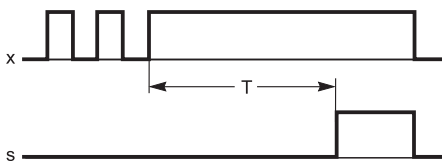
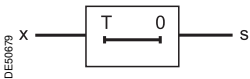

■ "off" delay timer: used to delay the disappearance of a signal by a time T.

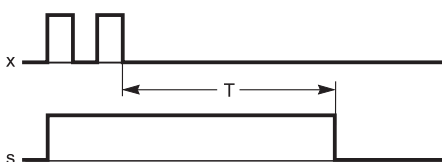
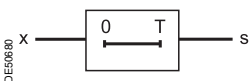

Pulse mode operation

■ "on" pulse: used to create a short-duration pulse (1 cycle) each time a signal appears

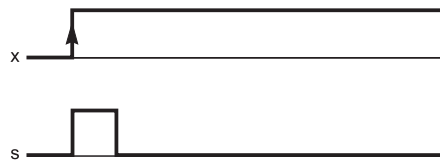
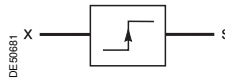

■ "off" pulse: used to create a short-duration pulse (1 cycle) each time a signal disappears.

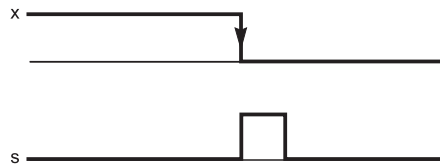
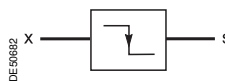

Note: the disappearance of a signal may be caused by an auxiliary power failure.

Bistable functions

Bistable functions may be used to store values.

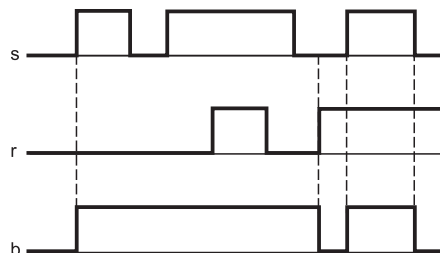
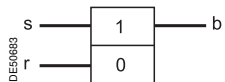

Equation: $B = S + \bar{R} \times B$.

Inputs and outputs may be assigned to predefined control and monitoring functions using the SFT2841 software, according to the uses listed in the table below.

- all the logic inputs, whether or not assigned to predefined functions, may be used for the SFT2841 customization functions according to specific application needs:
 - in the control matrix, to link inputs to output relays, LED indications or display messages
 - in the logic equation editor, as logic equation variables
- the control logic of each input may be inverted for undervoltage type operation.

Functions	S40	S41	S42	S43	S44	S50	S51	S52	S53	S54	T40	T42	T50	T52	M41	G40	Assignment
Logic inputs																	
Open position	■	■	■	■	■	■	■	■	■	■	■	■	■	■	■	■	I11
Closed position	■	■	■	■	■	■	■	■	■	■	■	■	■	■	■	■	I12
Logic discrimination, blocking reception 1	■	■	■	■	■	■	■	■	■	■	■	■	■	■	■	■	Free
Logic discrimination, blocking reception 2			■					■									Free
Switching of groups of settings A/B	■	■	■	■	■	■	■	■	■	■	■	■	■	■	■	■	I13
External reset	■	■	■	■	■	■	■	■	■	■	■	■	■	■	■	■	Free
External tripping 1	■	■	■	■	■	■	■	■	■	■	■	■	■	■	■	■	Free
External tripping 2	■	■	■	■	■	■	■	■	■	■	■	■	■	■	■	■	Free
External tripping 3	■	■	■	■	■	■	■	■	■	■	■	■	■	■	■	■	Free
Buchholz/gas tripping											■	■	■	■			Free
Thermostat tripping											■	■	■	■			Free
Pressure tripping											■	■	■	■			Free
Thermistor tripping											■	■	■	■	■	■	Free
Buchholz/gas alarm											■	■	■	■			Free
Thermostat alarm											■	■	■	■			Free
Pressure alarm											■	■	■	■			Free
Thermistor alarm											■	■	■	■	■	■	Free
End of charging position	■	■	■	■	■	■	■	■	■	■	■	■	■	■	■	■	Free
Inhibit remote control	■	■	■	■	■	■	■	■	■	■	■	■	■	■	■	■	Free
SF6	■	■	■	■	■	■	■	■	■	■	■	■	■	■	■	■	Free
Inhibit recloser	■	■	■	■	■	■	■	■	■	■							Free
External network synchronization	■	■	■	■	■	■	■	■	■	■	■	■	■	■	■	■	I21
Inhibit thermal overload											■	■	■	■	■	■	Free
Switching of thermal settings											■	■	■	■	■	■	Free
Motor re-acceleration															■		Free
Rotor rotation detection															■		Free
Inhibit undercurrent															■		Free
Inhibit closing	■	■	■	■	■	■	■	■	■	■	■	■	■	■	■	■	Free
Open order	■	■	■	■	■	■	■	■	■	■	■	■	■	■	■	■	Free
Close order	■	■	■	■	■	■	■	■	■	■	■	■	■	■	■	■	Free
Phase voltage transformer fuse melting	■	■	■	■	■	■	■	■	■	■	■	■	■	■	■	■	Free
Residual voltage transformer fuse melting	■	■	■	■	■	■	■	■	■	■	■	■	■	■	■	■	Free
External positive active energy counter	■	■	■	■	■	■	■	■	■	■	■	■	■	■	■	■	Free
External negative active energy counter	■	■	■	■	■	■	■	■	■	■	■	■	■	■	■	■	Free
External positive reactive energy counter	■	■	■	■	■	■	■	■	■	■	■	■	■	■	■	■	Free
External negative reactive energy counter	■	■	■	■	■	■	■	■	■	■	■	■	■	■	■	■	Free
Downstream load start up						■	■	■	■	■			■	■			Free
Logic outputs																	
Tripping	■	■	■	■	■	■	■	■	■	■	■	■	■	■	■	■	O1
Trip lockout	■	■	■	■	■	■	■	■	■	■	■	■	■	■	■	■	O2
Watchdog	■	■	■	■	■	■	■	■	■	■	■	■	■	■	■	■	O4
Close order	■	■	■	■	■	■	■	■	■	■	■	■	■	■	■	■	O11

Note: all the logic inputs are available via the communication link and accessible in the SFT2841 matrix for other non predefined applications.

The table below lists the logic input assignment obtained with the SFT2841 software by clicking on the "Standard assignment" button.

Functions	S40	S41	S42	S43	S44	S50	S51	S52	S53	S54	T40	T42	T50	T52	M41	G40	Standard assignment	
Logic inputs																		
Open position	■	■	■	■	■	■	■	■	■	■	■	■	■	■	■	■	■	I11
Closed position	■	■	■	■	■	■	■	■	■	■	■	■	■	■	■	■	■	I12
Logic discrimination, blocking reception 1	■	■	■	■	■	■	■	■	■	■	■	■	■	■			■	I13
Logic discrimination, blocking reception 2			■					■										I21
Switching of groups of settings A/B																■		I13
External reset	■	■	■	■	■	■	■	■	■	■	■	■	■	■	■	■	■	I14
External tripping 1	■	■		■	■	■	■		■	■						■	■	I21
External tripping 2	■	■	■	■	■	■	■	■	■	■						■	■	I22
External tripping 3	■	■	■	■	■	■	■	■	■	■						■	■	I23
Buchholz/gas tripping											■	■	■	■				I21
Thermostat tripping											■	■	■	■				I22
Pressure tripping											■	■	■	■				I23
Downstream load start up						■	■	■	■	■			■	■				I24
Inhibit remote control	■	■	■	■	■	■	■	■	■	■	■	■	■	■	■	■	■	I25
SF6	■	■	■	■	■	■	■	■	■	■	■	■	■	■	■	■	■	I26

Description

Sepam is used to control breaking devices equipped with different types of closing and tripping coils:

- circuit breakers with shunt trip or undervoltage trip units (parameter setting of O1 in the front of the advanced UMI or using SFT2841)
- latching contactors with shunt trip units.

Integrated circuit breaker / contactor control

This function controls the breaking device. It is coordinated with the recloser and logic discrimination functions and includes the anti-pumping function.

It performs the following operations according to the parameter setting:

- tripping on output O1 by:

- protection unit (units configured to trip the circuit breaker)
- logic discrimination
- remote control via the communication link
- external protection

- closing on output O11 by:

- recloser
- remote control via the communication link (remote control may be inhibited by the "inhibit remote control" logic input)

- closing control by logic input

- inhibition of closing on output O2 by:

- trip circuit fault (TCS)
- SF6 fault
- inhibit order by logic input.

Circuit breaker / contactor control with lockout function (ANSI 86)

The ANSI 86 function traditionally performed by lockout relays may be carried out by Sepam using the predefined Circuit breaker / contactor control function, with latching of all tripping conditions (protection function outputs and logic inputs).

With this function, Sepam performs the following:

- grouping of all tripping conditions and breaking device control
- latching of the tripping order with inhibition of closing until the cause of tripping disappears and is acknowledged by the user (see "Latching / acknowledgment", page 118)
- indication of the cause of tripping:

- locally by signal lamps ("Trip" and others) and by messages on the display
- remotely by remote indications (see "Use of remote indication bits", page 169).

Block diagram

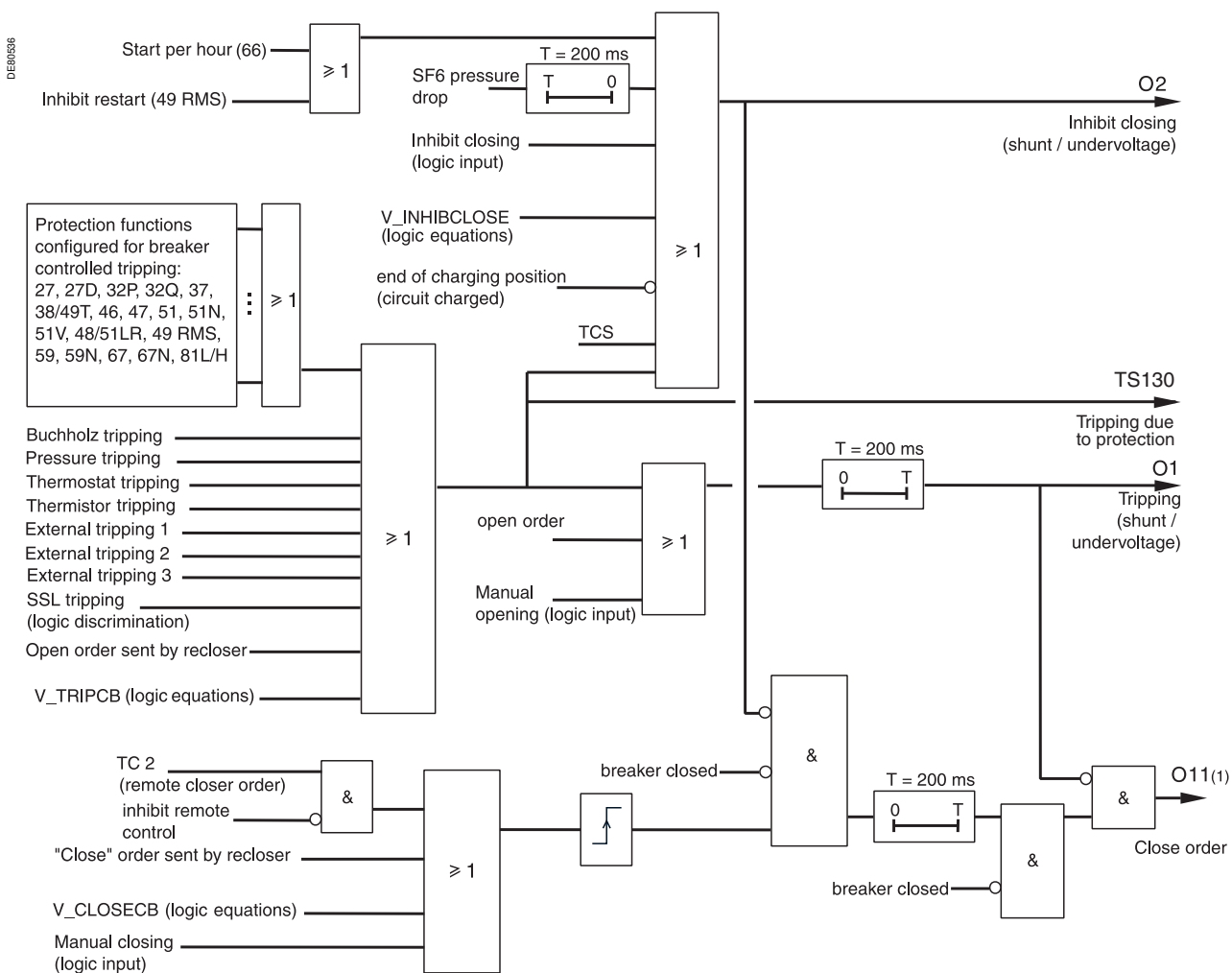

(1) The close order is only available when the MES114 option is included.

Monitoring Modbus S-LAN communication

Description

The Monitoring Modbus S-LAN communication function is used to trip the circuit breaker in the event of loss of communication with the Modbus master. This function is inhibited by default. It is activated with remote control order TC15 and can be inhibited after activation with remote control order TC16. Activation of this function is saved on loss of the auxiliary power supply. Loss of communication with the Modbus master is detected by the Sepam unit when remote control order TC15 has not been rewritten by the Modbus master at the end of an adjustable time delay T. The value of time delay T is set by the Modbus communication to address 5815. The setting range for the time delay is between 1 and 6553 s, in 0.1 s steps (default value 10 s).

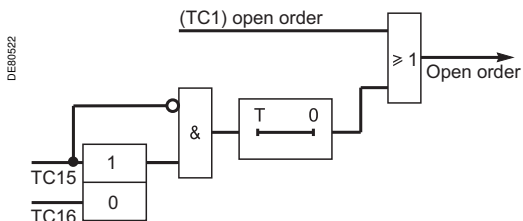

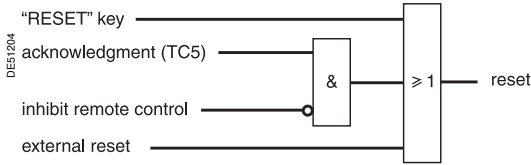

Latching/acknowledgment

Description

The tripping outputs of all the protection functions and all the logic inputs may be latched individually. Latched data are saved in the event of a power failure. Logic outputs may not be latched. The logic outputs set up in pulse mode maintain pulse-type operation, even when linked to latched data. All latched data may be acknowledged locally on the UMI, or remotely by means of a logic input or via the communication link. The remote indication TS104 remains present after latching operations until acknowledgment has taken place. The "Latching / acknowledgment" function associated with the "Circuit breaker / contactor control" function may be used to perform the ANSI 86 "Lockout relay" function.

TS/TC equivalence for each protocol

Modbus	DNP3	IEC 60870-5-103	IEC 61850
TS	Binary Input	ASDU, FUN, INF	LN.DO.DA
TS104	BI0	1, 160, 16	LLN0.LEDRs.stVal
TC	Binary Output	ASDU, FUN, INF	LN.DO.DA
TC5	BO2	20, 160, 19	LLN0.LEDRs.ctlVal

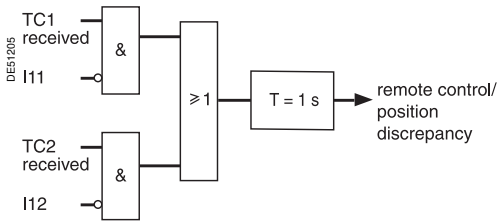

TC/circuit breaker position discrepancy

Description

This function detects a discrepancy between the last remote control order received and the actual position of the circuit breaker. The information is accessible via remote indication TS105.

TS/TC equivalence for each protocol

Modbus	DNP3	IEC 60870-5-103	IEC 61850
TS	Binary Input	ASDU, FUN, INF	LN.DO.DA
TS105	BI12	-	-
TC	Binary Output	ASDU, FUN, INF	LN.DO.DA
TC1	BO0	20, 21, 1 (OFF)	CSWI1.Pos.ctlVal
TC2	BO1	20, 21, 1 (ON)	CSWI1.Pos.ctlVal

Tripping

Description

The information can be accessed via remote indication TS130. It indicates whether a Sepam internal or external protection has tripped.

TS/TC equivalence for each protocol

Modbus	DNP3	IEC 60870-5-103	IEC 61850
TS	Binary Input	ASDU, FUN, INF	LN.DO.DA
TS130	BI136	2, 160, 68	-

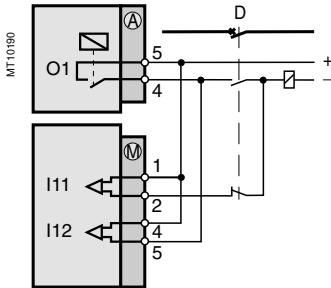

Wiring for shunt trip unit.

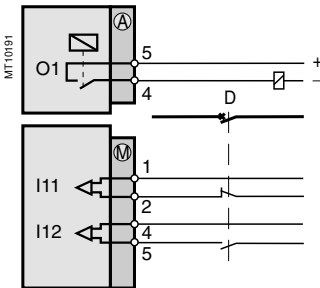

Wiring for undervoltage trip unit.

Trip circuit supervision and open / closed matching

Description

This supervision is designed for trip circuits:

- with shunt trip units

The function detects:

- circuit continuity
- loss of supply
- mismatching of position contacts.

The function inhibits closing of the breaking device.

- with undervoltage trip units

The function detects:

- mismatching of position contacts, coil supervision being unnecessary in this case.
- The information is accessible in the matrix and via the remote indication TS106.

Block diagram (1)

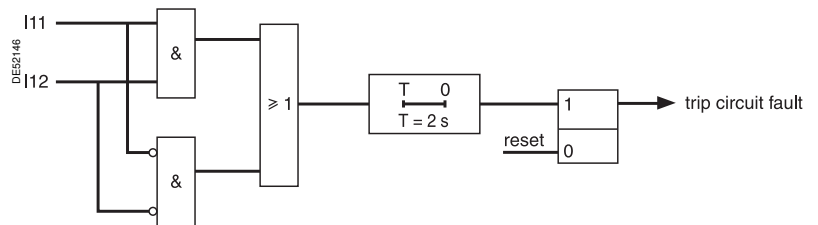

(1) With MES option.

The function is activated if inputs I11 and I12 are set respectively as circuit breaker "open position" and circuit breaker "closed position".

TS/TC equivalence for each protocol

Modbus	DNP3	IEC 60870-5-103	IEC 61850
TS	Binary Input	ASDU, FUN, INF	LN.DO.DA
TS106	BI11	1, 160, 36	XCBR1.EEHealth.stVal

Open and close order supervision

Description

Following a circuit breaker open or close order, the system checks whether, after a 200 ms time delay, the circuit breaker has actually changed status.

If the circuit breaker status does not match the last order sent, a "Control fault" message and remote indication TS108 are generated.

TS/TC equivalence for each protocol

Modbus	DNP3	IEC 60870-5-103	IEC 61850
TS	Binary Input	ASDU, FUN, INF	LN.DO.DA
TS108	BI10	1, 160, 36	Command Termination -

Application

This function provides:

- full tripping discrimination
 - a substantial reduction in delayed tripping of the circuit breakers located nearest the source (drawback of the classical time-based discrimination process).
- The system applies to the definite time (DT) and IDMT (standard inverse time SIT, very inverse time VIT, extremely inverse time EIT and ultra inverse time UIT) phase overcurrent, earth fault and directional protection functions.

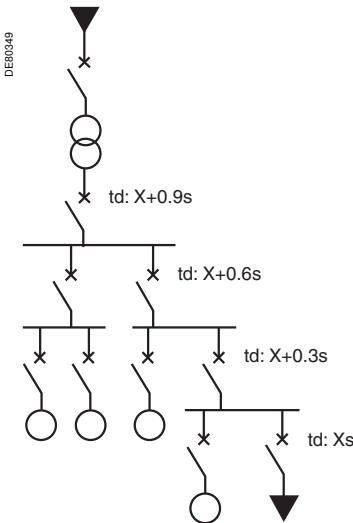

e.g. radial distribution with use of time-based discrimination (td: tripping time definite time curves).

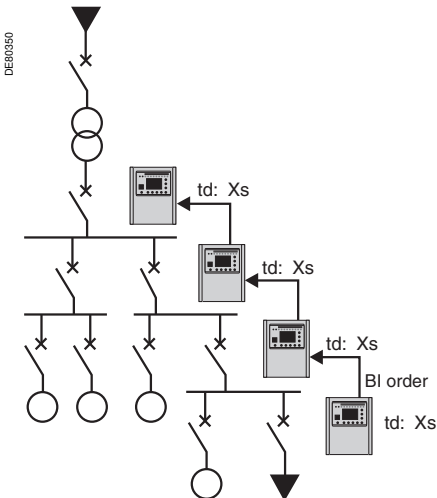

e.g.: radial distribution with use of the Sepam logic discrimination system.

With this type of system, time delays are set in accordance with the device to be protected, without any concern for the discrimination aspect.

Operating principle

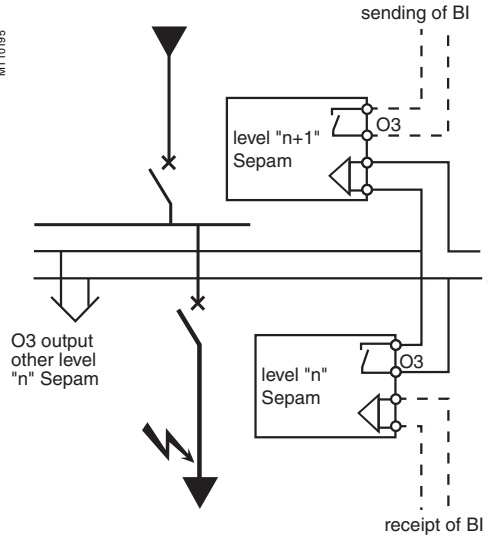

When a fault occurs in a radial network, the fault current flows through the circuit between the source and the location of the fault:

- the protection units upstream from the fault are triggered
- the protection units downstream from the fault are not triggered
- only the first protection unit upstream from the fault should trip.

Each Sepam is capable of sending and receiving blocking information except for motor Sepams ⁽¹⁾ which can only send blocking information.

When a Sepam is triggered by a fault current:

- it sends a blocking information to output O3 ⁽²⁾
- it trips the associated circuit breaker if it does not receive a blocking information on the logic input assigned to "receipt of BI" ⁽³⁾.

The sending of the blocking information lasts the time it takes to clear the fault. It is interrupted after a time delay that takes into account the breaking device operating time and protection unit reset time.

This system minimizes the duration of the fault, optimizes discrimination and guarantees safety in downgraded situations (wiring or switchgear failure).

Pilot wire test

The pilot wire test may be performed using the output relay test function.

⁽¹⁾ Motor Sepams are not affected by the receipt of a blocking information since they are designed for loads only.

⁽²⁾ Default parameter setting.

⁽³⁾ According to parameter setting and presence of an additional MES114 module.

Block diagram: Sepam S40, S41, S43, S44, S50, S51, S53, S54, T40, T42, T50, T52, G40

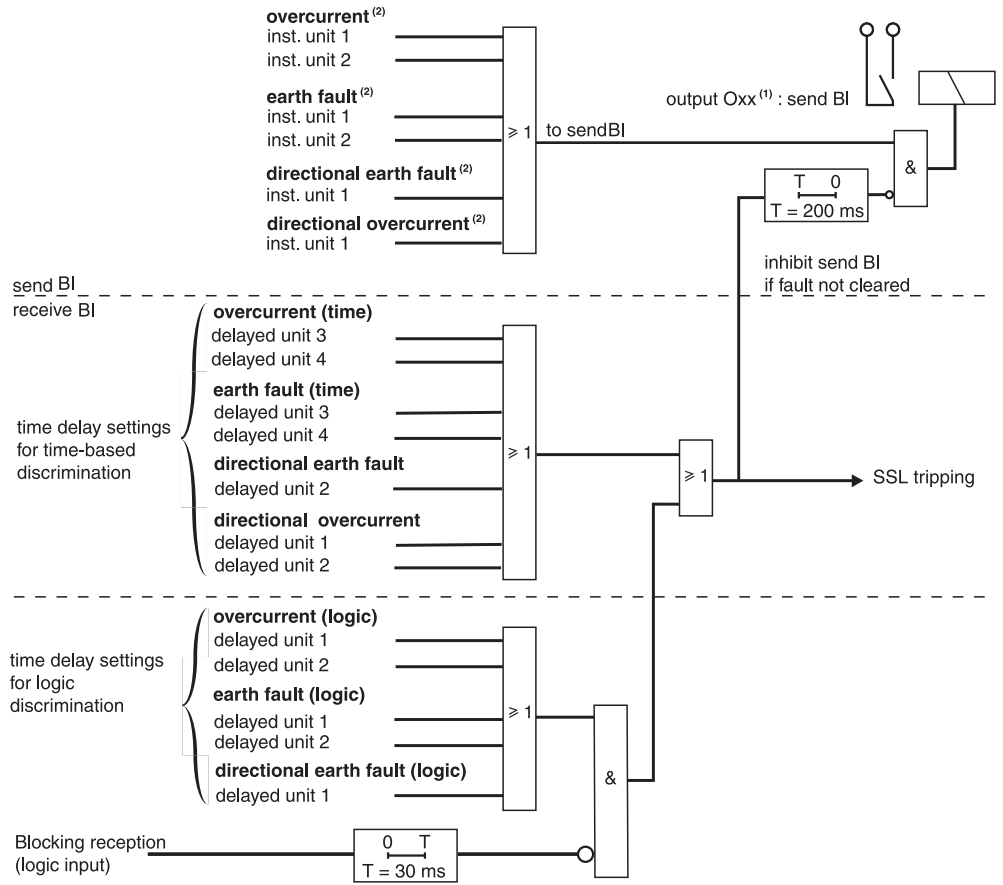

Block diagram: Sepam M40 and M41

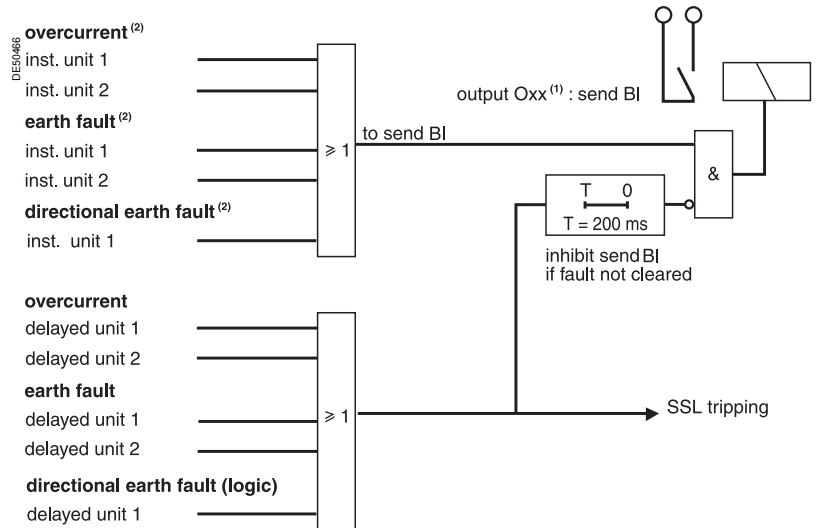

The protection units must be configured to trip the circuit breaker in order to be taken into account in logic discrimination.

(1) According to parameter setting (O3 by default).

(2) Instantaneous action (inst) corresponds to protection "pick up" signal information.

DES0465

Application

Closed ring network protection may be provided using Sepam S42 or S52 which includes the following functions:

- 2 units of directional phase (67) and earth fault (67N) protection functions:
 - a unit to detect faults located in the "line" direction
 - a unit to detect faults located in the "busbar" direction
- doubled logic discrimination function, with:
 - sending of 2 blocking information, according to the direction of the fault detected
 - receipt of 2 blocking information to block the directional protection relays according to their detection direction.

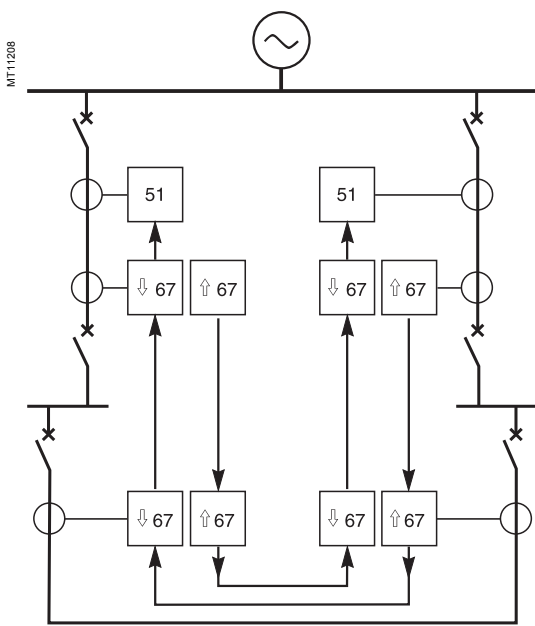

↓, ↑ : direction of 67/67N protection functions
↑ : direction of blocking signals

With the combination of the directional protection functions and the logic discrimination function, the faulty section may be isolated with minimum delay by the tripping of the circuit breakers on either side of the fault.

Blocking information are prepared by protection functions 67 and 67N.

Priority is given to protection function 67: when protection functions 67 and 67N detect faults in opposite directions at the same time, the blocking information is determined by the direction of the fault detected by protection function 67.

The instantaneous output of protection function 67, activated at 80 % of the Is set point, is used to send blocking information. This avoids uncertainty when the fault current is close to the Is set point.

Block diagram: Sepam S42, S52

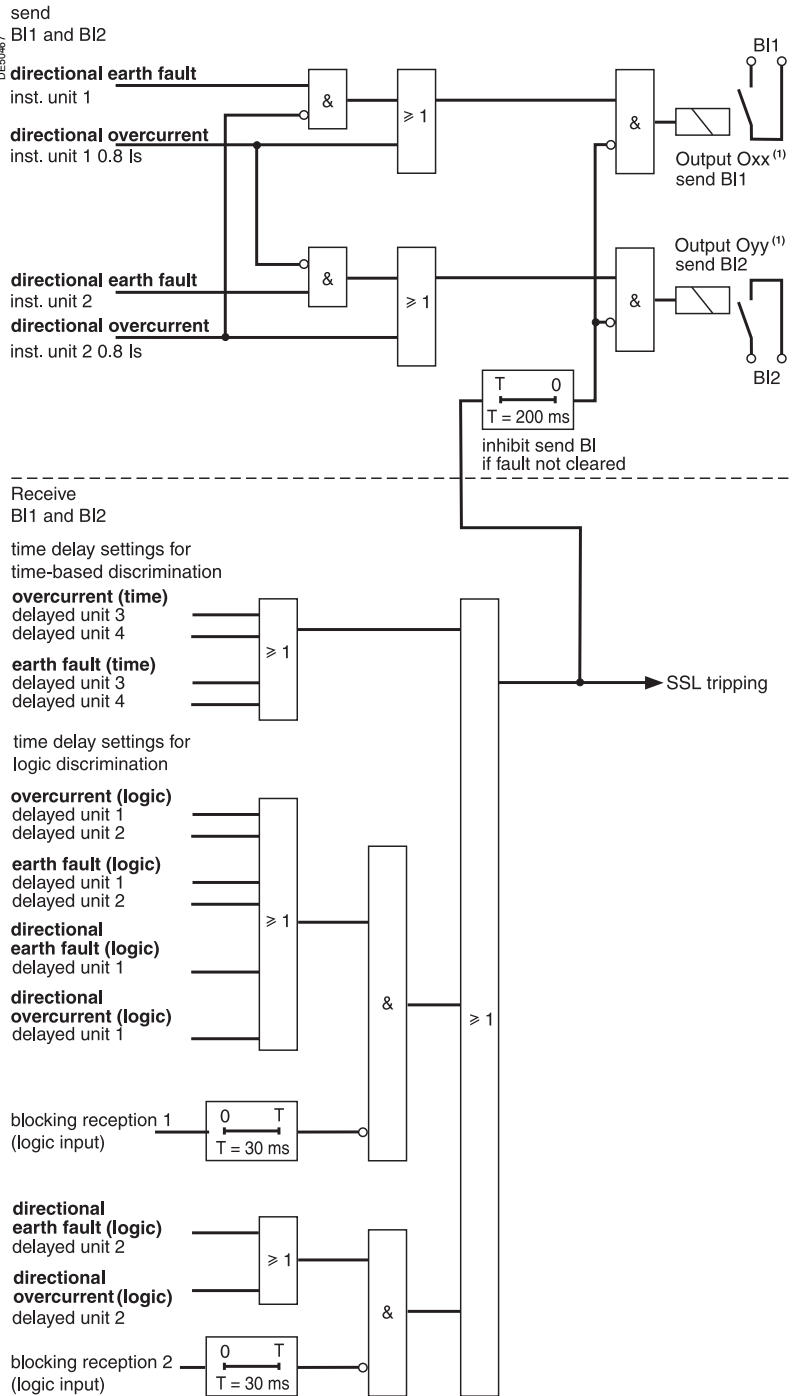

(1) According to parameter setting (by default): O3 for send BI1 and O12 for send BI2.

4

Example of closed ring protection function setting:

Case of a closed ring with two substations, each of which comprises two Sepam S42 or S52 relays, marked R11, R12 and R21, R22.

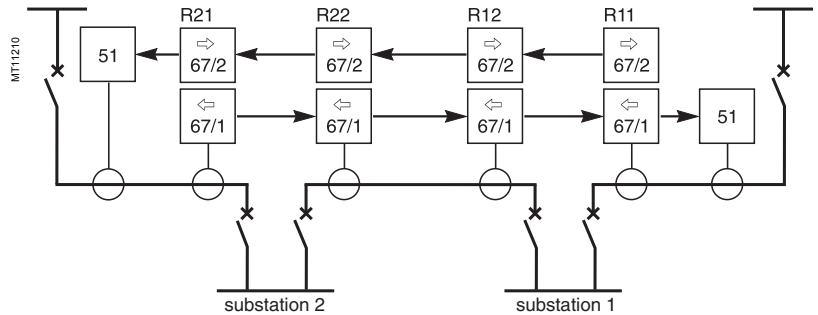

↔, ⇔ : direction of 67/67N protection functions
 ▲ : direction of blocking signals

Starting at one end of the ring, the detection direction of units 1 and 2 of the directional protection functions should be alternated between line and busbar.

Example of setting of the different Sepam with logic discrimination:

Substation 1

Sepam S42 or S52 no. R11

- Logic input/output assignment:
I13: blocking reception 1
- O3: send blocking information BI1
O12: send blocking information BI2
- 67, 67N, unit 1:
tripping direction = busbar
- 67, 67N, unit 2:
tripping direction = line

Sepam S42 or S52 no. R12

- Logic input/output assignment:
I13: blocking reception 1
I14: blocking reception 2
- O3: send blocking information BI1
O12: send blocking information BI2
- 67, 67N, unit 1:
tripping direction = line
- 67, 67N, unit 2:
tripping direction = busbar

Substation 2

Sepam S42 or S52 no. R22

- Logic input/output assignment:
I13: blocking reception 1
I14: blocking reception 2
- O3: send blocking information BI1
O12: send blocking information BI2
- 67, 67N, unit 1:
tripping direction = busbar
- 67, 67N, unit 2:
tripping direction = line

Sepam S42 or S52 no. R21

- Logic input/output assignment:
I13: blocking reception 1
- O3: send blocking information BI1
O12: send blocking information BI2
- 67, 67N, unit 1:
tripping direction = line
- 67, 67N, unit 2:
tripping direction = busbar

Logic discrimination ANSI code 68 Substation with 2 parallel incomers

Application

Substations supplied by 2 (or more) parallel incomers may be protected using Sepam S42 or S52, or Sepam T42 or T52, by a combination of directional phase (67) and earth fault (67N) protection functions, with the logic discrimination function.

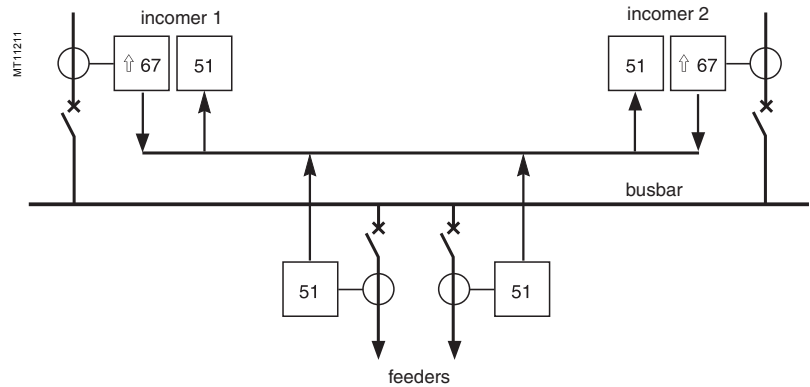

↑ : direction of 67/67N protection functions

▲ : direction of blocking signals

To avoid both incomers tripping when a fault occurs upstream from one incomer, the incomer protection devices must operate as follows:

- protection 67 of the faulty incomer detects the fault current in the "line" direction, the protection tripping direction:
 - sends a blocking information to inhibit the phase overcurrent protection functions (50/51) of both incomers
 - and trips the incomer circuit breaker
- protection function 67 of the fault-free incomer is insensitive to fault current in the "busbar" direction.

Examples of parallel incomer protection function setting

Protection by Sepam S42 or S52

- logic input/output assignment:
 - I13: blocking reception 1 - **Do not assign any inputs to blocking reception 2**
 - O3: send blocking information B11
- protection function 67 unit 1: tripping direction = line
 - instantaneous output: send blocking information B11
 - time-delayed output: inhibited by receipt of B11 on I13
- protection function 67, unit 2: tripping direction = line
 - time-delayed output: tripping of circuit breaker triggered by fault upstream from incomer (not inhibited since no input is assigned to blocking reception 2).

Protection by Sepam T42 or T52

- logic input/output assignment:
 - I13: blocking reception 1
 - O3: send blocking information B11
- protection function 67 unit 1: tripping direction = line
 - instantaneous output: send blocking information B11
 - time-delayed output: tripping of circuit breaker triggered by a fault upstream from the incomer (not inhibited by the receipt of B11 on I13)
- protection function 67, unit 2: if necessary.

Description

The recording of analog and logic signals may be triggered by different events, according to control matrix parameter setting or by manual action:

- triggering by the grouping of all pick-up signals of the protection functions in service
- triggering by the delayed outputs of selected protection functions
- triggering by selected logic inputs
- triggering by selected outputs Vx (logic equations)
- manual triggering by a remote control order (TC10)
- manual triggering via the SFT2841 software tool.

Disturbance recording may be:

- inhibited via the SFT2841 software or by remote control order (TC8)
- validated via the SFT2841 software or by remote control order (TC9).

Block diagram

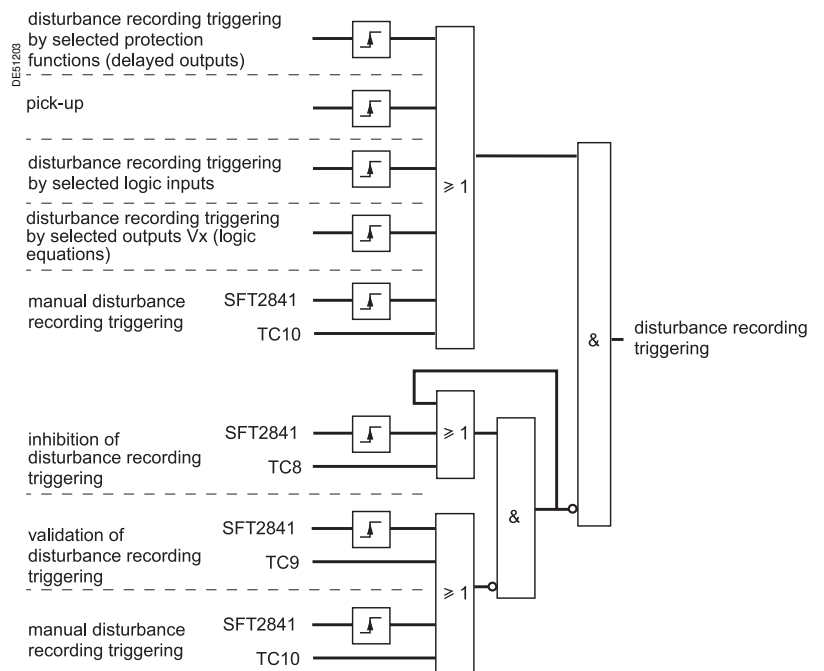

TS/TC equivalence for each protocol

Modbus	DNP3	IEC 60870-5-103	IEC 61850
TC	Binary Output	ASDU, FUN, INF	LN.DO.DA
TC8	BO3	-	RDRE1.RcdInh.ctlVal
TC9	BO4	-	RDRE1.RcdInh.ctlVal
TC10	BO5	-	RDRE1.RcdTrg.ctlVal

Description

There are two groups of settings, group A / group B, for the phase overcurrent, earth fault and, directional phase overcurrent and directional earth fault protection functions. Switching from one group of settings to another makes it possible to adapt the protection characteristics to suit the electrical environment of the application (change of earthing system, transition to local production, ...). The switching of settings is global and therefore applies to all the units of the protection functions mentioned above.

The setting switching mode is determined by parameter setting:

- switching according to the position of logic input I13 (0 = group A, 1 = group B)
- switching by remote control (TC3, TC4)
- forced group A or group B.

Block diagram

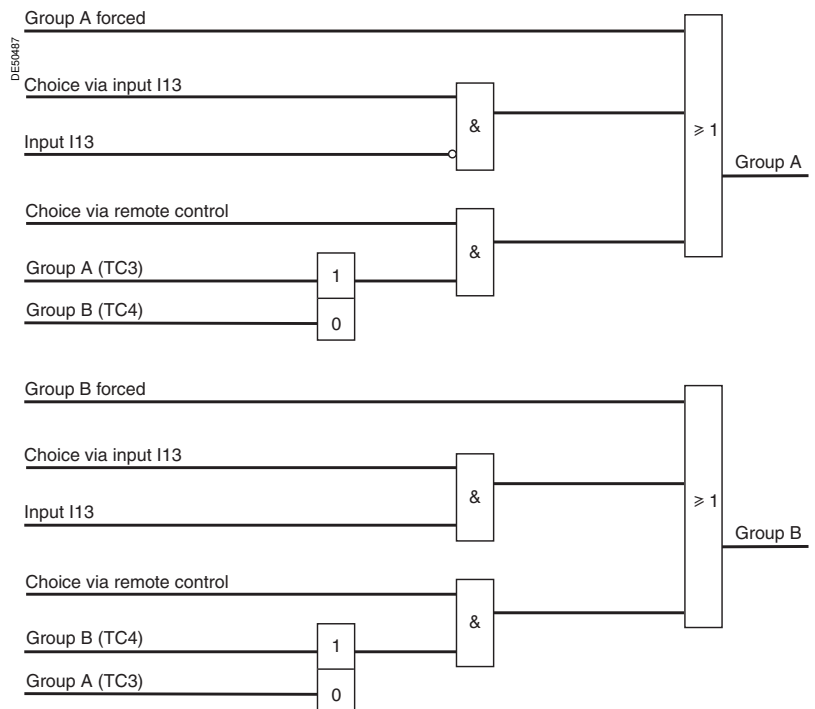

TS/TC equivalence for each protocol

Modbus	DNP3	IEC 60870-5-103	IEC 61850
TC	Binary Output	ASDU, FUN, INF	LN.DO.DA
TC3	BO8	20, 160, 23	LLN0.SGCB.SetActiveSettingGroup
TC4	BO9	20, 160, 24	LLN0.SGCB.SetActiveSettingGroup

Events may be indicated on the front panel of Sepam by:

- appearance of a message on the display of the advanced UMI
- lighting up of one of the 9 yellow signal lamps.

Message type indication

Predefined messages

All the messages connected to the standard Sepam functions are predefined and available in two language versions:

- in English, factory messages, not modifiable
- in the local language, according to the version delivered.

The language version is chosen at the time of Sepam parameter setting.

The messages are visible on the display units of Sepams equipped with the advanced UMI and in the SFT2841 Alarms screen. The predefined messages are identified by a number on the SFT2841 software screens.

■ The number and type of predefined messages depend on the type of Sepam. The table below gives the complete list of all predefined messages.

List of messages

Functions	English (factory)	Local language (e.g. French)	Message number
Phase overcurrent	PHASE FAULT ⁽²⁾	DEFAULT PHASE ⁽²⁾	1
Voltage-restrained phase overcurrent	O/C V RESTRAINT ⁽²⁾	DEF. PHASE RET.U ⁽²⁾	50
Earth fault	EARTH FAULT	DEFAULT TERRE	2
Breaker failure	BREAKER FAILURE	DEF. DISJONCT.	40
Negative sequence/unbalance	UNBALANCE I	DESEQUILIBRE I	5
Broken conductor detection	BROKEN CONDUCT.	RUPTURE COND.	52
Directional phase overcurrent	DIR. PHASE FAULT ⁽²⁾	DEFAULT PHASE DIR. ⁽²⁾	38
Directional earth fault	DIR. EARTH FAULT	DEFAULT TERRE DIR.	37
Active overpower	REVERSE P	RETOUR P	36
Reactive overpower	REVERSE Q	RETOUR Q	46
Thermal overload	THERMAL ALARM	ECHAUF ^T . ALARME	3
	THERMAL TRIP	ECHAUF ^T . DECL ^T .	4
	START INHIBIT	DEMARRAGE INHIBE	8
Locked rotor/	ROTOR BLOCKING	BLOCAGE ROTOR	6
Locked rotor at startup	ST ^{RT} LOCKED ROT ^R .	BLOC ROTOR DEM	27
Excessive starting time	LONG START	DEMARRAGE LONG	7
Number of starts	START INHIBIT	DEMARRAGE INHIBE	8
Phase undercurrent	UNDER CURRENT	COURANT <<	9
Overvoltage	OVERVOLTAGE ⁽³⁾	TENSION >> ⁽³⁾	10
Undervoltage	UNDERVOLTAGE ⁽³⁾	TENSION << ⁽³⁾	11
Positive sequence undervoltage	UNDERVOLT. PS	TENSION Vd<<	12
	ROTATION	ROTATION	39
Neutral voltage displacement	V0 FAULT	DEFAULT V0	13
Overfrequency	OVER FREQ.	FREQUENCE >>	14
Underfrequency	UNDER FREQ.	FREQUENCE <<	15
Negative sequence overvoltage	UNBALANCE V	DESEQUILIBRE V	18
Temperature (RTDs) ⁽¹⁾	OVER TEMP. ALM	T° ALARME	16
	OVER TEMP. TRIP	T°. DECL ^T .	17
	RTD'S FAULT (1 to 2)	DEFAULT SONDES (1 à 2)	32, 51
Thermostat	THERMOS ^T . ALARM	THERM ^{OT} . ALARME	26
	THERMOS ^T . TRIP	THERMOS ^T . DECL ^T .	23
Buchholz	BUCHHOLZ ALARM	BUCHH ALARME	25
	BUCHH/GAS TRIP	BUCHH/GAZ DECL ^T .	22
Pressure	PRESSURE ALM.	PRESSION ALARME	42
	PRESSURE TRIP	PRESSION DECL ^T .	24
Thermistor PTC/NTC	THERMIS ^T . ALARM	THERM ST . ALARME	44
	THERMIS ^T . TRIP	THERMIS ^T . DECL ^T .	45
External tripping x (1 to 3)	EXT. TRIP x (1 to 3)	DECL ^T . EXT. x (1 à 3)	33, 34, 35
Trip circuit supervision	TRIP CIRCUIT	CIRCUIT DECL ^T .	20
Circuit breaker control	CONTROL FAULT	DEFAULT COM ^{DE} .	21
Recloser	CYCLE x (1 to 4) (4)	CYCLE x (1 à 4) (4)	28, 29, 30, 31
Recloser	FINAL TRIP	DECL ^T DEFINITIF.	41
Recloser	CLEARED FAULT	DEFAULT ELIMINE	19
SF6	SF6 LOW	BAISSE SF6	43
Phase VT supervision	VT FAULT	DEFAULT TP	48
V0 VT supervision	VT FAULT V0	DEFAULT TP V0	49
CT supervision	CT FAULT	DEFAULT TC	47

(1) RTD FAULT message: refer to the maintenance chapter.

(2) With indication of the faulty phase.

(3) With indication of the faulty phase, when used with phase-to-neutral voltage.

(4) With indication of the protection unit that has initiated the cycle (phase fault, earth fault, etc.).

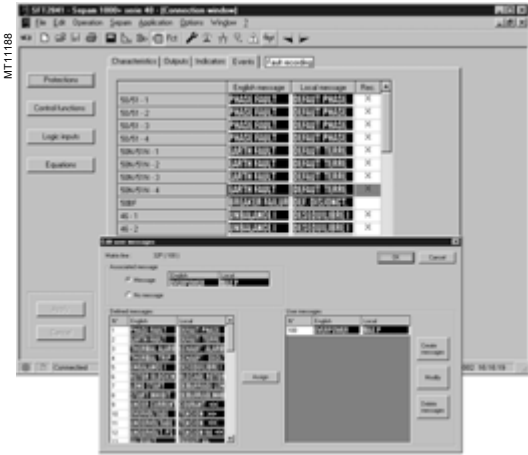

Personalized message editor.

Personalized user messages

30 additional messages may be created using the SFT2841 software to link a message to a logic input or the result of a logic equation, for example, or to replace a predefined message by a personalized message.

Personalized user message editor in SFT2841

The personalized message editor is integrated in the SOFT2841 software tool and may be accessed in connected or unconnected mode, from the control matrix screen:

- display on the screen the "Event" tab associated with "Protection": the predefined messages associated with the protection functions appear
- double-click on one of the messages displayed to activate the personalized message editor.

Personalized message editor functions

- creation and modification of personalized messages:
 - in English and the local language
 - by text input or importing of an existing bitmap file (*.bmp) or by point to point drawing
- deletion of personalized messages
- assignment of predefined or personalized messages to an event defined in the control matrix:
 - from the control matrix screen, "Events" tab, double-click on the event to be linked to a new message
 - select the new predefined or personalized message, from among the messages presented
 - and "Assign" it to the event.

The same message may be assigned to several events, with no restriction.

Message display in SFT2841

- the predefined messages are stored in Sepam's memory and appear:
 - written out in text format in connected mode
 - in code number format in unconnected mode
- the personalized messages are saved with the other Sepam parameters and protection settings and are displayed written out in text format in connected and unconnected modes.

Message processing on the advanced UMI display

When an event occurs, the related message appears on the advanced UMI display.

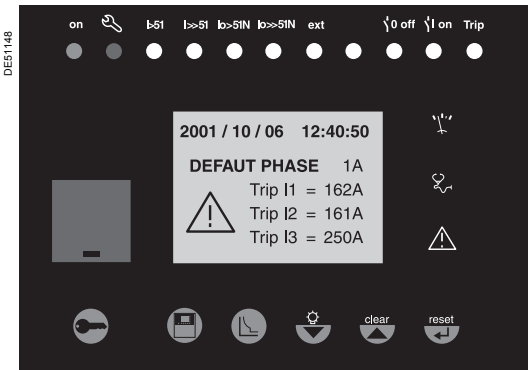

Alarm message on the advanced UMI.

The user presses the key to clear the message and be able to consult all the advanced UMI screens in the normal fashion. The user must press the key to acknowledge latched events (e.g. protection outputs). The list of messages remains accessible in the alarm history (key), in which the last 16 messages are stored. The last 250 messages may be consulted with the SFT2841 software.

To delete the messages stored in the alarm history:

- display the alarm history on the advanced UMI
- press the key.

Signal lamp type indication

The 9 yellow signal lamps on the front of Sepam are assigned by default to the following events:

Signal lamp	Event	Label on front panel
LED 1	Tripping of protection 50/51 unit 1	I>51
LED 2	Tripping of protection 50/51 unit 2	I>>51
LED 3	Tripping of protection 50N/51N unit 1	Io>51N
LED 4	Tripping of protection 50N/51N unit 2	Io>>51N
LED 5		Ext
LED 6		
LED 7	Circuit breaker open (I11) ⁽¹⁾	0 off
LED 8	Circuit breaker closed (I12) ⁽¹⁾	I on
LED 9	Tripping by circuit breaker control	Trip

⁽¹⁾ Assignment by default with MES114.

The default parameter setting may be personalized using the SFT2841 software:

- the assignment of signal lamps to events is to be defined in the control matrix screen, "LEDs" tab
- editing and printing of personalized labels are proposed in the "Sepam" menu.

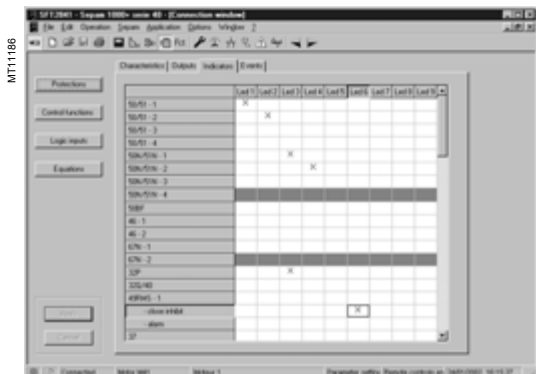

SFT2841: control matrix.

The control matrix is used for simple assignment of the logic outputs and signal lamps to information produced by the protection units, program logic and logic inputs. Each column creates a logic OR between all the lines selected. The matrix may also be used to display the alarms connected to the information. It guarantees the consistency of the parameter setting with the predefined functions. The following data are managed in the control matrix and may be set using the SFT2841 software tool.

Data	Meaning	Comments
"Protections" button		
All of the application protection functions	Protection time-delayed output and additional outputs when applicable	Additional actions in the "Characteristic" tab: In service / out of service Protection latching Participation of the protection unit in circuit breaker tripping
"Control functions" button		
Tripping	Tripping by the circuit breaker control function	Forced on O1
Inhibit closing	Inhibition of closing by the circuit breaker control function	Forced on O2
Closing	Closing by the circuit breaker control function	Forced on O11 (requires an MES114)
Pick-up	Logical OR of the instantaneous output of all protection units	
Drop-out	A protection unit time delay counter has not yet gone back to 0.	
TCS fault	Trip circuit fault	
Remote control discrepancy / Circuit breaker position	Discrepancy between the last state ordered by the remote monitoring and control system and the position of the circuit breaker	
CB control fault	A circuit breaker open or close order has not been executed	
Fault recording inhibition	Disturbance recording inhibited	
Sending of blocking information BI1	Sending of the blocking information to the following Sepam in logic discrimination chain 1	O3 by default
Sending of blocking information BI2	Sending of the blocking information to the next Sepam in logic discrimination chain 2	O12 by default On Sepam S42 or S52 only
Tripping by logic discrimination	Tripping order sent by the logic discrimination function	Only when the logic discrimination function is used without the circuit breaker control function
Cleared fault	The recloser function has successfully reclosed	Impulse type output
Final trip	The circuit breaker is definitively open after the reclosing cycles	Impulse type output
Recloser ready	The recloser is ready to carry out the cycles	
Recloser in service	The recloser is in service	
Recloser cycle 1	Cycle 1 in progress	
Recloser cycle 2	Cycle 2 in progress	
Recloser cycle 3	Cycle 3 in progress	
Recloser cycle 4	Cycle 4 in progress	
Reverse phase rotation	The voltages measured are rotating in reverse	
MET148-1 fault MET148-2 fault	Hardware problem on an MET module (module 1 or 2) or on an RTD	
Watchdog	Monitoring of Sepam operation	Always on O4 if used
"Logic inputs" button		
Logic inputs I11 to I14	According to configuration	If MES114 module is configured
Logic inputs I21 to I26	According to configuration	If MES114 is configured
"Equations" button		
V1 to V10	Logical equation editor outputs	



Application

This function may be used to configure simple logic functions by combining data received from the protection functions or logic inputs. By using logic operators (AND, OR, XOR, NOT) and time delays, new processing operations and indications may be added to the existing ones.

The logic functions produce outputs that may be used:

- in the matrix to control relay outputs, light up LEDs or display new messages
- in the protection functions to create new inhibition or reset conditions, for example
- in circuit breaker control to add cases of circuit breaker tripping, closing or inhibition
- in disturbance recording to record particular logic data.

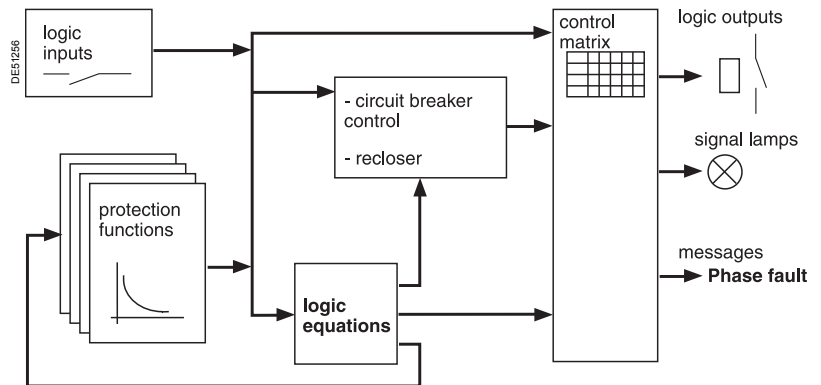

Logic function configuration

Logical functions are entered in text format in the SFT2841 editor. Each line includes a logic operation, the result of which is assigned to a variable.

Example:

V1 = P5051_2_3 OR I12

The lines are executed sequentially every 14 ms.

Description of operations

Operators

- **NOT**: logic inversion
- **OR**: logic OR
- **AND**: logic AND
- **XOR**: exclusive OR. **V1 XOR V2** is equivalent to **(V1 AND (NOT V2)) OR (V2 AND (NOT V1))**
- **=**: assignment of a result
- **//**: start of a comment, the characters on the right are not processed
- **()**: the operations may be grouped between brackets.

Functions

- **x = SR(y, z)**: bistable with priority given to Set
 - x is set to 1 when y is equal to 1
 - x is set to 0 when z is equal to 1 (and y is equal to 0)
 - x is unchanged in the other cases.
- **LATCH(x, y, ...)**: latching of variables x, y, ...
 - The variables are maintained constantly at 1 after having been set to 1 a first time. They are reset to 0 after Sepam is recharging ( key, external input or remote control order).
 - The LATCH function accepts as many parameters as the number of variables that the user wishes to latch.
 - It applies to the entire program, whatever the position in the program. For easier reading, it is advisable to put it at the start of the program.



Logical equation editor.

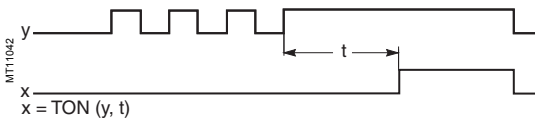

■ **x = TON(y, t):** on delay timer
The x variable follows the switching to 1 of the y variable with a delay t (t in ms).

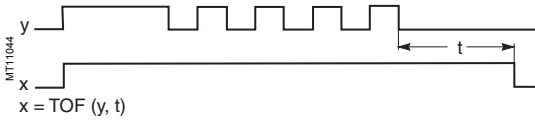

■ **x = TOF(y, t):** off delay timer
The x variable follows the switching to 0 of the y variable with a delay t (t in ms).

■ **x = PULSE(d, i, n):** time-tagger

Used to generate n periodic pulses, separated by a time interval i as of the starting time d

□ d is expressed as hour:minute:second

□ i is expressed as hour:minute:second

□ n is an integer (n = -1: repetition until the end of the day).

Example V1 = PULSE(8:30:00, 1:0:0,4) will generate 4 pulses at one-hour intervals at 8 h 30, 9 h 30, 10 h 30, 11 h 30. This will be repeated every 24 hours.

The pulses last for a 14 ms cycle. V1 has the value of 1 during the cycle.

If necessary, V1 may be extended using the **TOF**, **SR** or **LATCH** functions.

Maximum number of functions:

■ the total number of delay timers (TON and TOF) and time-tagger (PULSE) taken together cannot exceed 16

■ there is no limit on the number of bistable (SR) and latching (LATCH) functions.

Input variables

They come from protection functions or logic inputs. They may only appear on the right of the assignment sign:

■ **I11 to I14, I21 to I26:** logic inputs

■ **Pprotection_unit_data:** a protection output.

Example: **P50/51_2_1**, overcurrent protection, unit 2, data 1: time-delayed output.

The data numbers are detailed in the table which follows.

Output variables

They are directed to the matrix, or to the protection functions, or to the program logic functions. They may only appear on the left of the assignment sign:

The output variables should only be used once; otherwise the last assignment is taken into account.

■ **outputs to the matrix: V1 to V10**

The outputs are included in the matrix and may therefore control signal lamps, relay outputs or messages.

■ **outputs to a protection input: Pprotection_unit_data**

Example: **P59_1_113**, overvoltage protection, unit 1, data 113: protection inhibition.

The data numbers are detailed in the table which follows.

■ **outputs to program logic:**

□ **V_TRIPCB:** circuit breaker tripping by the circuit breaker control function. Used to complete circuit breaker tripping conditions and activate the recloser.

□ **V_CLOSECB:** circuit breaker closing by the circuit breaker control function. Used to generate a circuit breaker close order based on a particular condition.

□ **V_INHIBCLOSE:** inhibition of circuit breaker closing by the circuit breaker control function. Used to add circuit breaker closing inhibition conditions.

□ **V_FLAGREC:** data saved in disturbance recording. Used to save a specific logical status in addition to those already present in disturbance recording.

Local variables

Variables designed for intermediary calculations. They are not available outside the logic equation editor. They may appear on the left or right of the assignment sign.

There are 31 of them: **VL1** to **VL31**.

Two constants are also predefined: **K_1** always equal to 1 and **K_0** always equal to 0.

Details of protection inputs/outputs

The tables below list the input/output data available for each protection function. The SFT2841 software includes a data input assistance tool which may be used to quickly identify each data item:

- numbers less than 100 correspond to the protection outputs that may be used as equation input variables
- numbers between 100 and 199 correspond to the protection inputs that may be used as equation output variables
- numbers greater than 200 correspond to the recloser outputs that may be used as equation input variables.

Table of protection function input and output variables

Designation	Bit	21FL	27/27S	27D	27R	32P	32Q	37	38/49T	46	46BC	47	48/51 LR	49 RMS
Outputs														
Instantaneous output (pick-up)	1		■	■	■	■	■	■		■	■	■		
Protection output (time-delayed)	3		■	■	■	■	■	■	■	■	■	■	■	■
Drop-out	4													
Instantaneous output inverse zone	6													
Phase 1 fault	7		■ ⁽¹⁾											
Phase 2 fault	8		■ ⁽¹⁾											
Phase 3 fault	9		■ ⁽¹⁾											
Alarm	10								■					■
Inhibit closing	11													■
RTD fault	12								■					
Locked rotor	13												■	
Excessive starting time	14												■	
Locked rotor at startup	15												■	
Protection inhibited	16	■	■	■	■	■	■	■	■	■	■	■	■	■
Hot state	18													■
Positive active power	19					■								
Negative active power	20					■								
Instantaneous output at 0.8 Is	21													
Starting in progress	22												■	
Recloser in service	201													
Recloser ready	202													
Reclosing successful	203													
Permanent trip	204													
Reclosing cycle 1	211													
Reclosing cycle 2	212													
Reclosing cycle 3	213													
Reclosing cycle 4	214													
Inputs														
Reset	101		■	■	■	■	■	■	■	■	■	■	■	■
VT fault	103													
Start 50BF	107													
Inhibition	113	■	■	■	■	■	■	■	■	■	■	■	■	■
Closed circuit breaker	119													
Downstream load start up	120													

(1) When the protection is used with phase-to-neutral voltage.

4

Table of protection function input and output variables (continued)

Designation	Bit	50/51	CLPU 50/51	50BF	50N/ 51N	CLPU 50N/51N	51V	59	59N	66	67	67N	79	81H	81L	CT	VT
Outputs																	
Instantaneous output (pick-up)	1	■		■	■		■	■	■		■	■		■	■		
Protection output (time-delayed)	3	■		■	■		■	■	■	■	■	■		■	■	■	■
Drop-out	4	■			■		■				■	■					
Instantaneous output inverse zone	6										■	■					
Phase 1 fault	7	■					■	■ ⁽¹⁾			■					■	
Phase 2 fault	8	■					■	■ ⁽¹⁾			■					■	
Phase 3 fault	9	■					■	■ ⁽¹⁾			■					■	
Alarm	10																
Inhibit closing	11																
RTD fault	12																
Locked rotor	13																
Excessive starting time	14																
Locked rotor at startup	15																
Protection inhibited	16	■		■	■		■	■	■	■	■	■		■	■	■	■
Hot state	18																
Positive active power	19																
Negative active power	20																
Instantaneous output at 0.8 Is	21										■						
Starting in progress	22																
Recloser in service	201												■				
Recloser ready	202												■				
Reclosing successful	203												■				
Permanent trip	204												■				
Reclosing cycle 1	211												■				
Reclosing cycle 2	212												■				
Reclosing cycle 3	213												■				
Reclosing cycle 4	214												■				
Inputs																	
Reset	101	■		■	■		■	■	■	■	■	■	■	■	■		
VT fault	103																■
Start 50BF	107			■													
Inhibition	113	■		■	■		■	■	■	■	■	■	■	■	■	■	■
Closed circuit breaker	119			■													
Downstream load start up	120		■			■											

(1) When the protection is used with phase-to-neutral voltage.

Processing upon loss of auxiliary voltage

The V1 to V10, VL1 to VL 31 and V_TRIPCB, V_CLOSECB, V_INHIBCLOSE, V_FLAGREC variables are saved in the event of a Sepam auxiliary power outage. The status is restored when the power returns, allowing the statuses produced by LATCH, SR or PULSE type memory operators to be saved.

Special cases

■ brackets must be used in expressions which comprise different OR, AND, XOR or NOT operators:

- V1 = VL1 AND I12 OR P27/27S_1_1. // incorrect expression
- V1 = (VL1 AND I12) OR P27/27S_1_1. // correct expression
- V1 = VL1 OR I12 OR P27/27S_1_1. // correct expression

■ only the V1 to V10, VL1 to VL31 and V_TRIPCB, V_CLOSECB, V_INHIBCLOSE, V_FLAGREC variables are allowed in the LATCH function

■ function parameters cannot be expressions:

- VL3 = TON ((V1 AND V3), 300) // incorrect expression
- VL4 = V1 AND V3
- VL3 = TON (VL4, 300) // correct.

Use limit

The number of operators and functions (OR, AND, XOR, NOT, =, TON, TOF, SR, PULSE) is limited to 100.

Examples of applications

■ **latching of recloser final trip data**

By default, this data is of the impulse type at the recloser output. If required by operating conditions, it may be latched as follows:

LATCH (V1) // V1 may be latched

V1 = P79_1_204 // recloser "final trip" output.

V1 may then control a signal lamp or relay output in the matrix.

■ latching of a signal lamp without latching the protection function

Certain operating conditions call for the latching of indications on the front panel of Sepam, without latching of the trip output O1.

LATCH (V1, V2)

V1 = P50/51_1_1 OR P50/51_3_1 // tripping, units 1 and 3 of protection 50/51

V2 = P50/51_2_1 OR P50/51_4_1 // tripping, units 2 and 4 of protection 50/51

V1 and V2 must be configured in the matrix to control 2 front panel signal lamps.

■ circuit breaker tripping if input I13 is present for more than 300 ms.

V_TRIPCB = TON (I13, 300).

■ life line mode (example 1)

If work is underway with the power on (indicated by input I25), and the user wishes to change the relay behavior as follows:

1 - circuit breaker tripping by the instantaneous outputs of protection functions 50/51, unit 1 or 50N/51N, unit 1 AND if input I25 is present:

2 - Recloser inhibition:

P79_1_113 = I25

■ life line mode (example 2)

The user wishes to inhibit protection functions 50N/51N and 46 by an input I24:

P50N/51N_1_113 = I24

P46_1_113 = I24

■ validation of a 50N/51N protection function by logic input I21

An 50N/51N protection function set with a very low set point must only trigger tripping of the circuit breaker if it is validated by an input. The input comes from a relay which accurately measures the current in the neutral point:

V_TRIPCB = P50N/51N_1_3 AND I21

■ inhibition of circuit breaker closing if thermal alarm set points are overrun

The temperature protection function 38/49T supplies 16 alarm bits. If one of the first three bits is activated the user wishes to inhibit circuit breaker closing:

V_INHIBCLOSE = P38/49T_1_10 OR P38/49T_2_10 OR P38/49T_3_10.

Presentation

The reliability of a device is the property that allows its users to have well-placed confidence in the service it delivers.

For a Sepam protection relay, operational reliability consists of ensuring the safety and availability of the installation. This means avoiding the following 2 situations:

- Nuisance tripping of the protection

Continuity of the electrical power supply is as vital for a manufacturer as it is for an electricity distribution company. Nuisance tripping caused by the protection can result in considerable financial losses. This situation affects the availability of the installation.

- Failure of the protection to trip

The consequences of a fault that is not eliminated can be catastrophic. For safety of operation, the protection relay must detect faults in the power supply as quickly as possible, using discrimination. This situation affects the safety of the installation.

Self-tests and monitoring functions

On initialization and cyclically during operation, Sepam runs a series of self-tests. These self-tests are designed to detect any failure in its internal and external circuits so as to ensure Sepam's reliability. These failures are classified into 2 categories, major failures and minor failures:

- A major failure reaches the hardware resources used by the protection functions (program memory and analog input for example).

This type of failure risks resulting in failure to trip on a fault or nuisance tripping. In this case, Sepam must go into the fail-safe position as quickly as possible.

- A minor failure affects Sepam's peripheral functions (display, communication).

This type of failure does not prevent Sepam from protecting the installation and providing continuity of service. Sepam then operates in downgraded mode.

The classification of failures into 2 categories improves both safety and availability of the installation.

The possibility of a Sepam major failure must be taken into account when selecting the trip command type to maximize availability or safety of the installation (see "Selecting the trip command and examples of use" page 138).

In addition to the self-tests, the user can activate monitoring functions to improve the installation monitoring:

- VT supervision (ANSI code 60FL)

- CT supervision (ANSI code 60)

- Trip circuit and closing circuit supervision (ANSI code 74)

These functions send an alarm message to the Sepam display unit and a data item is automatically available to the communication to alert the user.

Self-tests

The self-tests are run when Sepam is initialized and/or during its operation.

List of self-tests which place Sepam in the fail-safe position

Failures which have caused this are deemed to be major ones.

Function	Test type	Execution period
Power supply		
	Power supply presence	During operation
CPU		
	Processor	On initialization and during operation
	RAM memories	On initialization and during operation
Program memory	Checksum	On initialization and during operation
Parameter memory	Checksum	On initialization
Analog inputs		
	Current	During operation
	Voltage	During operation
Logic outputs	Relay driver	On initialization and during operation
Connection		
	CCA630, CCA634, CCA670	On initialization and during operation
	MES114	On initialization and during operation

List of self-tests which do not place Sepam in the fail-safe position

Failures which have caused this are deemed to be minor ones.

Function	Test type	Execution period
UMI	Module presence	On initialization and during operation
Analog output	Module presence	On initialization and during operation
Temperature inputs	Module presence	On initialization and during operation

Fail-safe position

When Sepam is in working order, it runs self-tests continuously. Detection of a major failure places Sepam in the fail-safe position.

State of Sepam in the fail-safe position

- All the output relays are forced to the idle state
- All protection functions are inhibited
- The watchdog output indicates failure (output in the idle state)
- A red LED on the Sepam front panel is on and a diagnostic message appears on the Sepam display unit (see "Local indication ANSI code 30", page 127).

How Sepam deals with failures

- **Minor failure:** Sepam switches to downgraded operation. The failure is indicated on the Sepam display unit and also by the communication. Sepam continues to protect the installation.
- **Major failure:** Sepam switches to the fail-safe position and attempts a restart during which it again runs its self-tests. There are 2 possible scenarios:
 - The internal failure is still present. It is a permanent failure. Intervention on Sepam is required. Only removing the cause of the failure, followed by de-energizing and then energizing Sepam, will allow the unit to exit the fail-safe position.
 - The internal failure is no longer present. It is a transient failure. Sepam restarts so that it can continue to protect the installation. Sepam has been in the fail-safe position for 5 to 7 s.

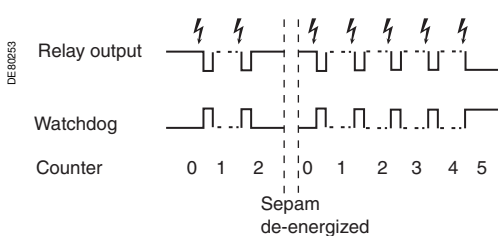
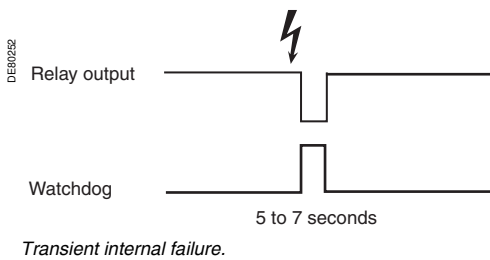
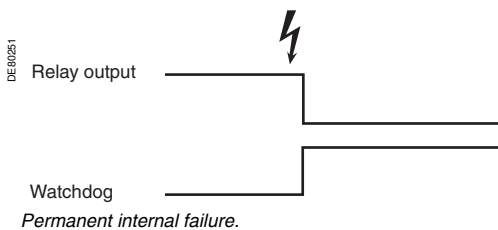

Limiting the number of transient failure detections

Each time a transient internal failure appears, Sepam increments an internal counter. The fifth time the failure occurs, Sepam is placed in the fail-safe position. De-energizing Sepam reinitializes the failure counter. This mechanism can be used to avoid keeping a Sepam running that is subject to repeated transient failures.

Selecting the trip command and examples of use

An analysis of the operational reliability of the whole installation should determine whether availability or safety of this installation should be prioritized if Sepam is in the fail-safe position. This information is used to determine the choice of trip command as outlined in the table below.

NOTICE
RISK OF UNPROTECTED INSTALLATION
 Always connect the watchdog output to a monitoring device when the selected trip command does not result in the installation tripping when Sepam fails.
Failure to follow these instructions can result in equipment damage.

Selecting the trip command

Diagram	Control	Event	Trip	Advantage	Disadvantage
1	Shunt trip breaker or mechanical latching contactor	Sepam failure or loss of the auxiliary power supply	No	Availability of the installation	Installation not protected until remedial intervention ⁽¹⁾
2	Breaker with undervoltage trip coil (fail-safe)	Sepam failure or loss of the auxiliary power supply	Yes	Safety of the installation	Installation not available until remedial intervention
3	Breaker with undervoltage trip coil (not fail-safe)	Sepam failure	No	Availability of the installation	Installation not protected until remedial intervention ⁽¹⁾
		Loss of auxiliary power supply	Yes	Safety of the installation	Installation not available until remedial intervention

⁽¹⁾ It is essential to use the watchdog, see the warning notice opposite.

Example of use with shunt trip coil (diagram 1)

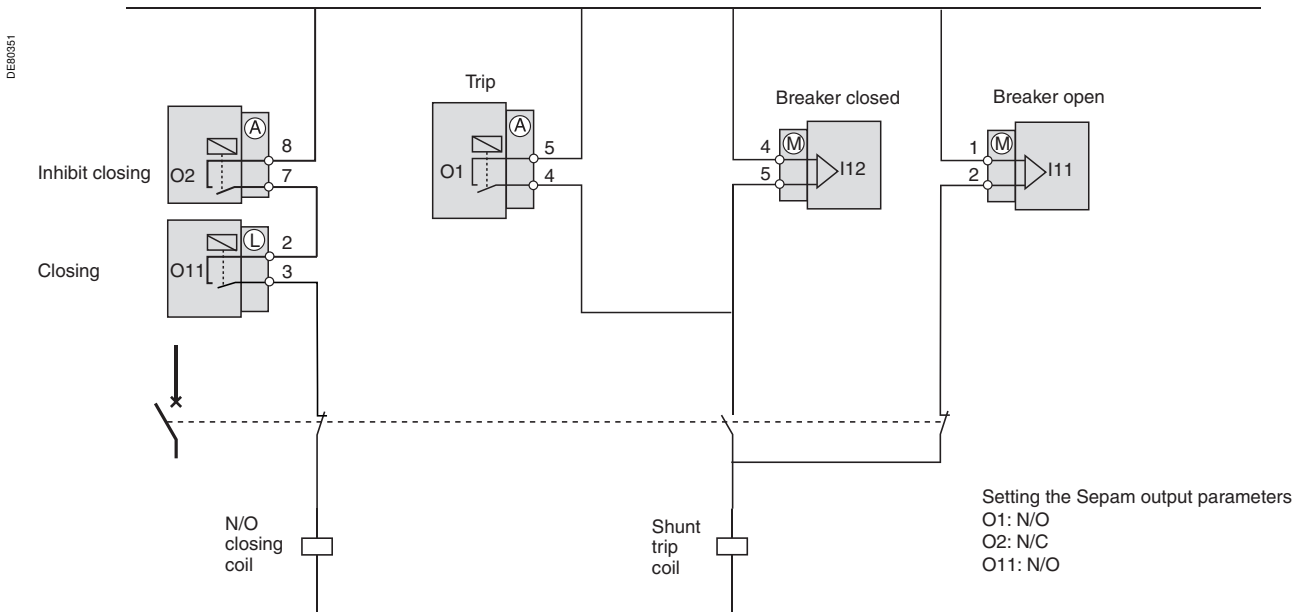

Example of use with undervoltage trip coil with fail-safe condition (diagram 2)

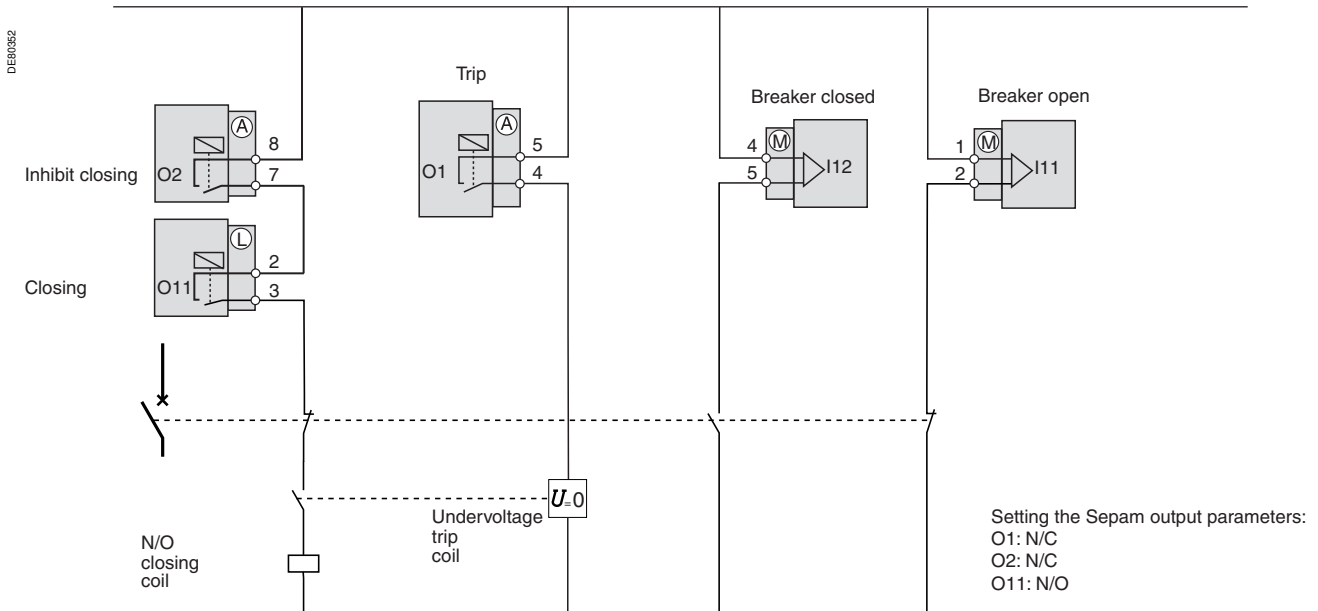

Example of use with undervoltage trip coil without fail-safe condition (diagram 3)

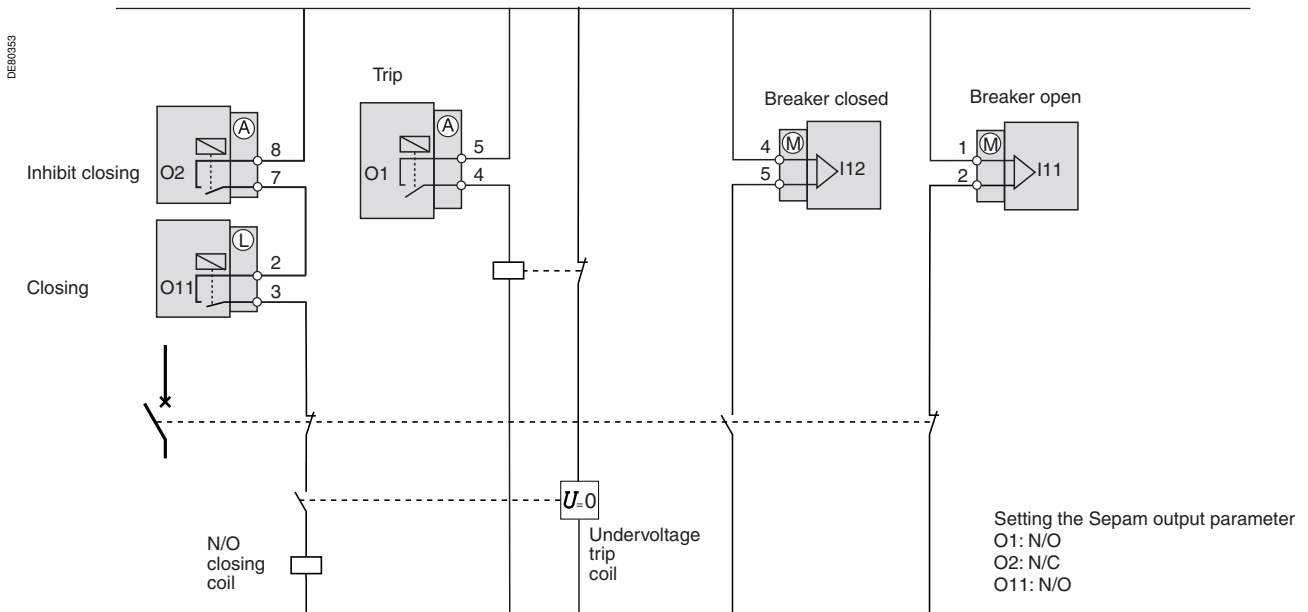

Using the watchdog

The watchdog is extremely important in the monitoring system, as it indicates to the user that the Sepam protection functions are working correctly. When Sepam detects an internal failure, a LED flashes automatically on the Sepam front panel regardless of whether the watchdog output is connected correctly. If the watchdog output is not correctly connected to the system, this LED is the only way of knowing that Sepam has failed. We therefore strongly recommend connecting the watchdog output at the highest level of the installation so that an effective alarm is generated when necessary. For example, an audible alarm or flashing alarm lamp can be used to warn the operator.

Watchdog output status	No failure detected	Failure detected
Watchdog output connected correctly to the control system	The protection functions are in working order	<ul style="list-style-type: none"> ■ The protection functions are not working. ■ Sepam is in the fail-safe position. ■ The Sepam alarm LED flashes. ■ The watchdog output activates a system alarm. ■ The operator is warned that he needs to intervene.
Watchdog output not connected	The protection functions are in working order	<ul style="list-style-type: none"> ■ The protection functions are not working. ■ Sepam is in the fail-safe position. ■ The Sepam alarm LED flashes. ■ The need of maintenance is detected only if an operator controls the front panel of the digital relay.

4

Presentation	142
Modbus protocol	143
Configuring the communication interfaces	146
Commissioning and diagnosis	152
Data addresses and encoding	160
Time-tagging of events	173
Access to remote settings	178
Access to remote settings	182
Disturbance recording	195
Reading Sepam identification	197

General

Modbus communication allows Sepam to be connected to a supervisor or any other device with a master Modbus communication channel. Sepam is always a slave station.

Sepam is connected to a Modbus communication network via a communication interface.

There is a choice of 3 types of communication interface:

- Communication interfaces to connect Sepam to a single serial network:
 - ACE949-2, for connection to a 2-wire RS 485 network
 - ACE959, for connection to a 4-wire RS 485 network
 - ACE937, for connection to a fiber-optic star network.
- Communication interfaces to connect Sepam to two serial networks:
 - ACE969TP-2, for connection to:
 - one 2-wire RS 485 Modbus S-LAN supervision communication network
 - one 2-wire RS 485 E-LAN engineering communication network
 - ACE969FO-2, for connection to:
 - one fiber-optic Modbus S-LAN supervision communication network
 - one 2-wire RS 485 E-LAN engineering communication network.
- Communication interfaces to connect Sepam to an Ethernet network:
 - ACE850TP for electrical connection to the network
 - ACE850FO for optical connection to the network

Data available

The data available depend on the type of Sepam.

Measurement readout

- phase and earth fault currents
- peak demand phase currents
- tripping currents
- cumulative breaking current
- phase-to-phase, phase-to-neutral and residual voltages
- active, reactive and apparent power
- active and reactive energy
- frequency
- temperatures
- thermal capacity used
- starts per hour and inhibit time
- running hours counter
- motor starting current and time
- operating time before overload tripping
- waiting time after tripping
- operating time and number of operations
- circuit breaker charging time.

Program logic data readout

- a table of 144 pre-assigned remote indications (TS) (depends on the type of Sepam) enables the readout of program logic data status
- readout of the status of 10 logic inputs.

Remote control orders

Writing of 16 impulse-type remote control orders (TC) in either direct mode or SBO (Select Before Operate) mode via 16 selection bits.

Other functions

- reading of Sepam configuration and identification
- time-tagging of events (synchronization via the network or externally via logic input I21), time-tagging within a millisecond
- remote reading of Sepam settings
- remote setting of protection units
- remote control of the analog output (with MSA141 option)
- transfer of disturbance recording data.

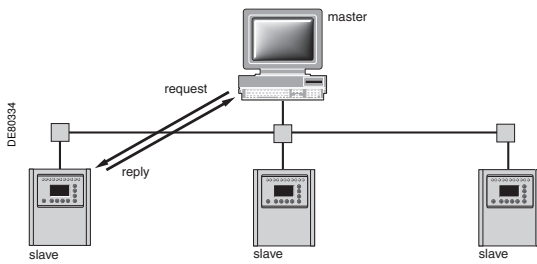

Exchanges

The Modbus protocol exchanges information using a request-reply mechanism between a master and a slave. An exchange is always initiated (request sent) by the master. The only action on the part of a slave is to reply to requests received. Where the communication network permits, several slaves units can be connected to a single master. A request contains the slave address (a unique number) to identify the recipient. Non-addressed slaves disregard the requests received.

Modbus Protocol Data Unit

Every Modbus request or response frame includes a Modbus PDU (protocol data unit) made up of 2 fields.

Function code	Data
---------------	------

- function code (1 byte): indicates the type of request (1 to 127)
 - data (0 to n bytes): depends on the function code, see below.
- If there is no error, the function codes in the reply and in the request are identical.

Modbus data types

Modbus uses 2 types of data: bits and 16-bit words (also called registers). Each element of data is identified by a 16-bit address. The most-significant byte in 16-bit words is always sent first, for both data and addresses.

Modbus functions supported

The Modbus protocol used by Sepam is a compatible sub-group of the RTU Modbus protocol.

The functions listed below are handled by Sepam:

- basic functions (data access)
 - function 1: reading of n output or internal bits
 - function 2: reading of n input bits
 - function 3: reading of n output or internal words
 - function 4: reading of n input words
 - function 5: writing of 1 bit
 - function 6: writing of 1 word
 - function 7: high-speed reading of 8 bits
 - function 15: writing of n bits
 - function 16: writing of n words.
- communication-management functions:
 - function 8: Modbus diagnosis
 - function 11: reading of Modbus event counter
 - function 43: sub-function 14: reading of identification

The following exception codes are supported:

- 1: unknown function code
- 2: incorrect address
- 3: incorrect data
- 4: not ready (cannot process request)
- 7: not acknowledged (remote reading and setting).

Modbus specification

The full description of the Modbus protocol can be found at www.modbus.org.

This description is limited to the Modbus protocol using a serial link in binary mode (RTU mode).

Frames

All the frames exchanged have the same structure, made up of 3 parts.

Slave address	Modbus PDU	Check (CRC16)
---------------	------------	---------------

- Slave address (1 byte): from 1 to 247 (0 for broadcasting)
 - Modbus PDU: as previously described
 - Check (2 bytes): CRC16 used to check frame integrity.
- The slave addresses in the reply and in the request are identical.
The maximum size of a frame is 256 bytes (255 for Sepam series 40).

Synchronization of exchanges

Any character that is received after a silence of more than 3.5 characters is considered as the beginning of a new frame. A minimum silence of 3.5 characters must always be observed between two frames.

A slave disregards all frames:

- received with a physical error for 1 or more characters (format error, parity error, etc.)
- with an incorrect CRC16 result
- for which it is not the recipient.

Broadcasting

The master can also address all slaves using the conventional address 0. This type of exchange is called broadcasting.

Slaves do not respond to broadcast messages. As a result, only messages that do not require the transmission of data by the slaves can be broadcast.

Response time

The communication coupler **response time (Tr)** is less than 15 ms, including a 3-character silence (approximately 3 ms at 9600 bauds).

This time is given with the following parameters:

- 9600 bauds
- format: 8 bits, odd parity, 1 stop bit.

DEE0299

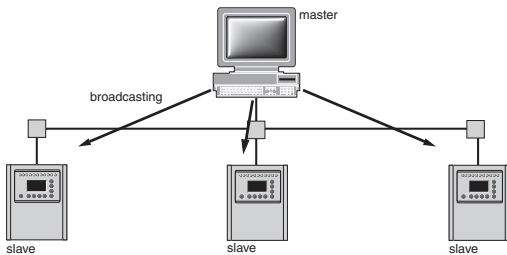

DEE2212

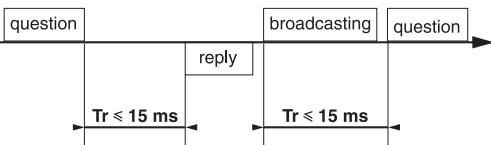

5

Requests and replies are exchanged as TCP/IP messages over a TCP connection. The slave address is therefore its IP address.

Frames

The application layer part of a Modbus/TCP frame is made up of 2 fields:

MBAP Header	Modbus PDU
-------------	------------

- MBAP (Modbus Application) Header (7 bytes): identifies the frame
- Modbus PDU: as previously described.

Modbus Application header

It contains the following fields:

Field	Length	Description	Request	Response
Transaction identifier	2 bytes	Identification of a Modbus request/response transaction	Field initialized by the client	Field copied by the server from the received request
Protocol identifier	2 bytes	0 = Modbus protocol	Field initialized by the client	Field copied by the server from the received request
Length	2 bytes	Number of following bytes (including unit identifier)	Field initialized by the client	Field initialized by the server
Unit identifier	1 byte	In case of gateways, identifies a remote slave device connected on a serial line. Should be 255 in other cases.	Field initialized by the client	Field copied by the server from the received request

Configuring the communication interfaces

Serial line communication

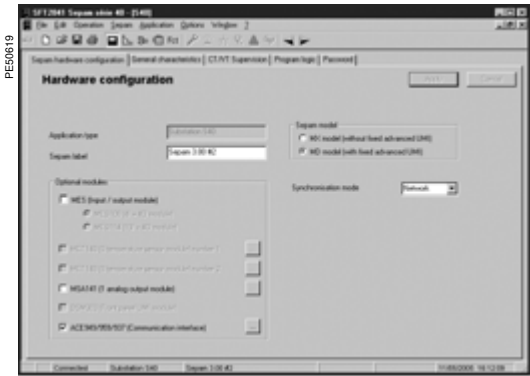

SFT2841: Sepam Configuration screen.

Access to configuration parameters

The Sepam communication interfaces are configured using SFT2841 software. The configuration parameters can be accessed from the Communication configuration window in SFT2841.

To access this window:

- open the **Sepam configuration** window in SFT2841
- check the box for ACExxx (communication interface)
- click : the **Communication configuration** window appears
- select the type of interface used: ACE949/ACE959/ACE937, ACE969TP or ACE969FO
- select the Modbus communication protocol.

The configuration parameters will vary depending on the communication interface selected: ACE949/ACE959/ACE937, ACE969TP or ACE969FO. The table below specifies the parameters to be configured depending on the communication interface chosen.

Parameters to be configured	ACE949 ACE959 ACE937	ACE969TP	ACE969FO
Physical layer parameters	■	■	■
Fiber-optic parameters			■
Modbus advanced parameters	■	■	■
E-LAN parameters		■	■



SFT2841: communication configuration window for ACE949.

Configuring the physical layer of the Modbus port

Asynchronous serial transmission is used with the following character format:

- 1 start bit
- 8 data bits
- 1 stop bit
- parity according to parameter setting.

The number of stop bits is always set at 1.

If a configuration with parity is selected, each character will contain 11 bits: 1 start bit + 8 data bits + 1 parity bit + 1 stop bit.

If a no parity configuration is selected, each character will contain 10 bits: 1 start bit + 8 data bits + 1 stop bit.

The configuration parameters for the physical layer of the Modbus port are:

- slave number (Sepam address)
- transmission speed
- parity check type.

Parameters	Authorized values	Default value
Sepam address	1 to 247	1
Speed	4800, 9600, 19200 or 38400 bauds	19200 bauds
Parity	None, Even or Odd	Even

Configuring the ACE969FO-2 fiber-optic port

The configuration for the physical layer of the ACE969FO-2 fiber-optic port is completed with the following 2 parameters:

- Link idle state: light-on or light-off
- Echo mode: with or without.

Fiber-optic parameters	Authorized values	Default value
Link idle state	Light Off or Light On	Light Off
Echo mode	Yes (fiber-optic ring) or No (fiber-optic star)	No

Note: in echo mode, the Modbus master will receive the echo of its own request before the slave's reply. The Modbus master must be able to disregard this echo. Otherwise, it is impossible to create a Modbus fiber-optic ring.

Configuring the communication interfaces

Serial line communication

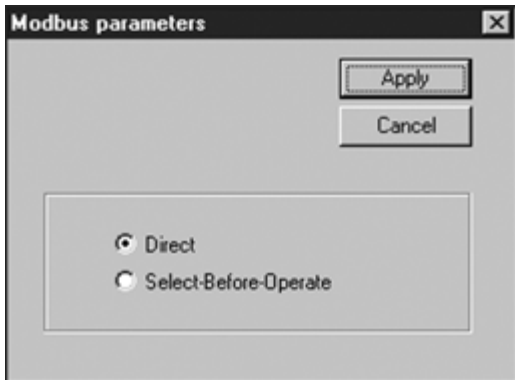

SFT2841: Modbus advanced parameters window.

Configuring Modbus advanced parameters

The Sepam remote control mode is selected from the Advanced parameters window.

Advanced parameters	Authorized values	Default value
Remote control mode	Direct or SBO (Select Before Operate) mode	Direct



SFT2841: communication configuration window for ACE969FO.

Configuring the physical layer of the ACE969-2 E-LAN port

The E-LAN port on the ACE969TP-2 and ACE969FO-2 communication interfaces is a 2-wire RS 485 port.

The configuration parameters for the physical layer of the E-LAN port are:

- Sepam address
- transmission speed
- parity check type.

The number of stop bits is always set at 1.

If a configuration with parity is selected, each character will contain 11 bits: 1 start bit + 8 data bits + 1 parity bit + 1 stop bit.

If a no parity configuration is selected, each character will contain 10 bits: 1 start bit + 8 data bits + 1 stop bit.

Parameters	Authorized values	Default value
Sepam address	1 to 247	1
Speed	4800, 9600, 19200 or 38400 bauds	38400 bauds
Parity	None, Even or Odd	Odd

Configuration tips

- The Sepam address MUST be assigned before Sepam is connected to the communication network.
- You are also strongly advised to set the other physical layer configuration parameters before making the connection to the communication network.
- Modifying the configuration parameters during normal operation will not disturb Sepam but will reset the communication port.

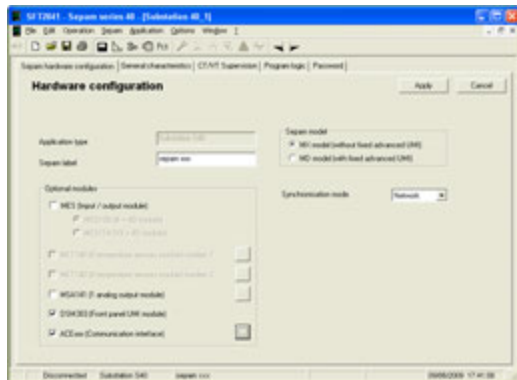

SFT2841: Sepam configuration screen.

Access to configuration parameters

The Sepam communication interfaces must be configured using SFT2841 software. The configuration parameters can be accessed from the Communication configuration window in the SFT2841 software.

To access this window:

- open the **Sepam configuration** window in SFT2841
- check the box for ACExxx (communication interface)
- click on the relevant button : the **Communication configuration** window appears
- select the type of interface used: ACE850TP or ACE850FO.

Configuring an ACE850 involves:

- configuring the standard Ethernet parameters (mandatory)
- configuring one or more of the following sets of advanced optional parameters:
 - SNMP: Ethernet network management
 - SNTP: time synchronization
 - IP filtering: access control
 - RSTP: Ethernet ring management
 - User accounts: access control.

Ethernet and TCP/IP configuration

Before configuring the ACE850, obtain a unique static IP address, subnet mask, and default gateway address from the network administrator. See the section on IP address and parameter guidelines, page 151.

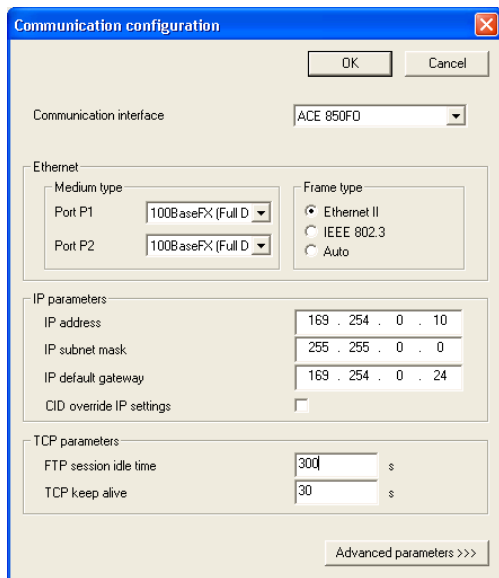

SFT2841: Ethernet and TCP/IP configuration.

Parameters	Description	Authorized values
Frame format	Used to select the format for data sent over an Ethernet connection.	Ethernet II, 802.3, Auto Default: Ethernet II
Media type	Used to define the physical Ethernet connection.	ACE850TP <ul style="list-style-type: none"> ■ 10T/100Tx Auto ■ 10BaseT-HD ■ 10BaseT-FD ■ 100BaseTX-HD ■ 100BaseTX-FD Default: 10T/100Tx Auto ACE850FO <ul style="list-style-type: none"> ■ 100BaseFX-HD ■ 100BaseFX-FD Default: 100BaseFX-FD
IP address	Used to enter the static IP address of the ACE850.	0.0.0.0 to 255.255.255.255 Default: 169.254.0.10
Subnet mask	Used to enter the subnet mask of your network.	0.0.0.0 to 255.255.255.255 Default: 255.255.0.0
Default gateway	Used to enter the default gateway (router) IP address used for wide area network (WAN) communications.	0.0.0.0 to 255.255.255.255 Default: 0.0.0.0
Allow CID file to override IP parameters	This parameter is not used for Modbus only communication.	Default: not checked
Keep alive	Timeout value used to test for session disconnection.	1 to 60 seconds Default: 30 seconds
FTP session inactivity timeout	Timeout value used to force disconnection of an inactive FTP session	30 to 900 seconds Default: 30 seconds

Duplicate IP address detection

The ACE850 IP address must be unique in the network. If it is not unique, the Status LED repeats a four blink-pause pattern and a new IP address must be assigned to the ACE850 or to the conflicting device.

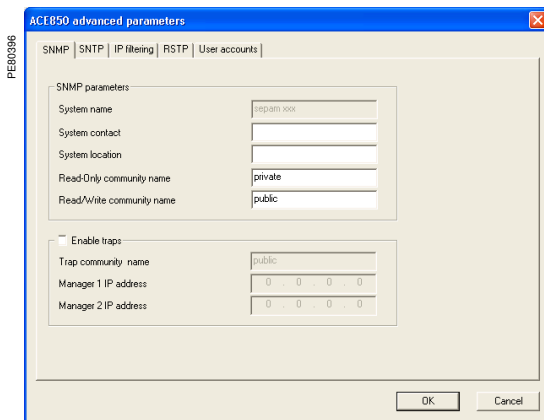

SFT2841: SNMP configuration.

SNMP configuration

The ACE850 supports SNMP V1, allowing a network administrator to remotely access it with an SNMP manager and view the network status and diagnostics in the MIB2 format (only a subset of MIB2 is implemented).

Additionally, the ACE850 may be configured to send SNMP traps in the following cases:

- ACE850 start/restart
- Link up
- Link down
- Authentication failure.

Parameters	Description	Authorized values
System Name	This parameter is the same as the Sepam label.	Not modifiable from this screen.
System Contact	Name of the administrative contact	String (< 16 characters) Default: empty string
System Location	Location of the Sepam/ACE850	String (< 16 characters) Default: empty string
Read-only Community Name	SNMP community that has read-only access to the MIB. Acts as a password.	String (< 16 characters) Default: "public"
Read-write Community Name	SNMP community that has read-write access to the MIB. Acts as a password.	String (< 16 characters) Default: "private"
Enable traps	Checking this check box enables SNMP to send traps.	Default: "not checked"
Traps Community Name	SNMP community that is used with traps.	String (< 16 characters) Default: "public"
Manager 1 IP address	IP address of the SNMP manager to which traps are sent.	0.0.0.0 to 255.255.255.255 Default: 0.0.0.0
Manager 2 IP address	IP address of a second SNMP manager to which traps are sent.	0.0.0.0 to 255.255.255.255 Default: 0.0.0.0

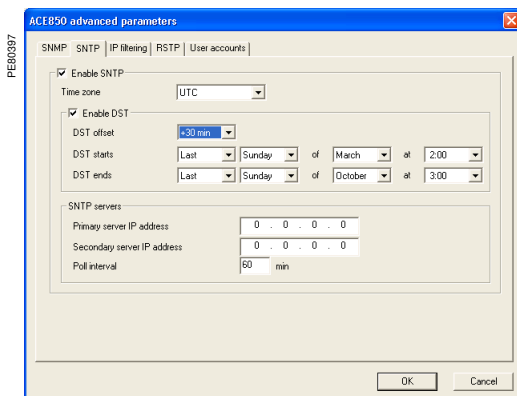

SFT2841: SNTP configuration.

SNTP configuration

SNTP is a time synchronization protocol that can be used to synchronize the Sepam. SNTP is used in mode 3-4 (unicast mode).

- If SNTP is used, the synchronization source for Sepam must be defined as Ethernet.
- If SNTP is not used, the Sepam synchronization must be ensured by other means (Modbus frames, synchronization tops).

Parameters	Description	Authorized values
Enable SNTP	Enables the time and date of the Sepam to be set by the Simple Network Time Protocol (SNTP) server.	Default: not enabled
Time Zone Offset	Determines the difference between local time and Coordinated Universal Time (UTC) (same as GMT).	UTC-12 to UTC+14 Default: UTC
Enable Daylight Saving Time	Enables the use of Daylight Saving Time (Summer time).	Default: not enabled
DST offset	Difference between standard time and Daylight Saving Time.	+ 30 or + 60 minutes Default: + 60 minutes
DST starts	If enabled, DST starts on the selected date.	Default: last Sunday of March
DST ends	If enabled, DST ends on the selected date.	Default: last Sunday of October
Primary Server IP Address	The IP address of the SNTP server the ACE850 contacts to get the time message.	0.0.0.0 to 255.255.255.255 Default: 0.0.0.0
Secondary Server IP Address	The IP address of another SNTP server the ACE850 contacts in case the primary server is down.	0.0.0.0 to 255.255.255.255 Default: 0.0.0.0
Poll Interval	Controls how often the ACE850 contacts the SNTP server for the correct time.	1 to 300 minutes Default: 60 minutes

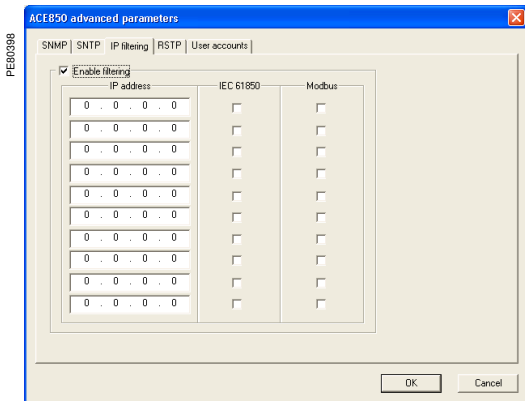

SFT2841: IP filtering configuration.

IP filtering configuration

The IP filtering function allows the administrator to specify which Modbus/TCP clients and which IEC 61850 clients have access to the ACE850 services.

Note: if IP filtering is enabled, access is forbidden to any client not in the filtered list.

Parameters	Description	Authorized values
Enable filtering	Check this box to activate filtering based on IP addresses.	Default: not enabled
IP address	The IP address of a client for which filtering options are defined.	0.0.0.0 to 255.255.255.255 Default: 0.0.0.0
IEC 61850	Check this box to grant IEC 61850 access to the given IP address.	Default: not checked
Modbus	Check this box to grant Modbus/TCP access to the given IP address.	Default: not checked

RSTP configuration

The RSTP protocol enables the use of redundant Ethernet architectures such as rings.

It must be enabled each time the ACE850 is included in a loop. It may be disabled in other cases.

Changing the default settings is normally not required and should be performed with extreme care as it could jeopardize the stability of the Ethernet network.

If in doubt, it is always possible to revert to the default values using the Default settings button.

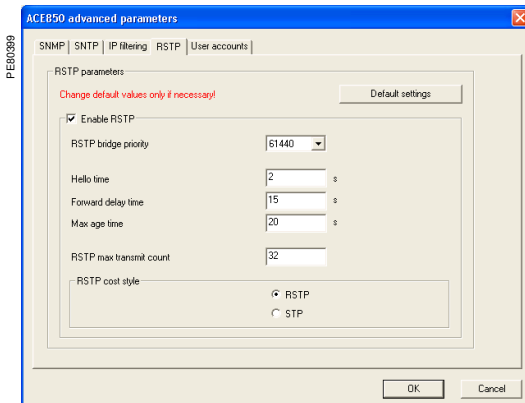

SFT2841: RSTP configuration.

Parameters	Description	Authorized values
Enable RSTP	Check this box to activate the use of the RSTP protocol.	Default: enabled
Bridge priority	Priority of the bridge. The bridge with the lowest priority becomes root.	0 - 61440, by steps of 4096 Default: 61440
Hello time	Amount of time between the transmission of configuration messages	1 to 10 seconds Default: 2 seconds
Forward delay time	Time value to control how fast a port changes its spanning state when moving towards the forwarding state	4 to 30 seconds Default: 21 seconds
Max age time	Valid duration of configuration message once sent by the root bridge	6 to 40 seconds Default: 40 seconds
Max transmit count	Maximum BPDUs that can be transmitted by the Port Transmit state machine in any Hello time. This value limits the maximum transmission rate.	3 to 100 Default: 32
Cost style	RSTP (32 bits) or STP (16 bits) cost style selection	Default: RSTP

Note: RSTP parameters must verify the following relationships:

- $2 \times (\text{Forward_delay_time} - 1 \text{ second}) \geq \text{Max_age_time}$
- $\text{Max_age_time} \geq 2 \times (\text{Hello_time} + 1 \text{ second})$.

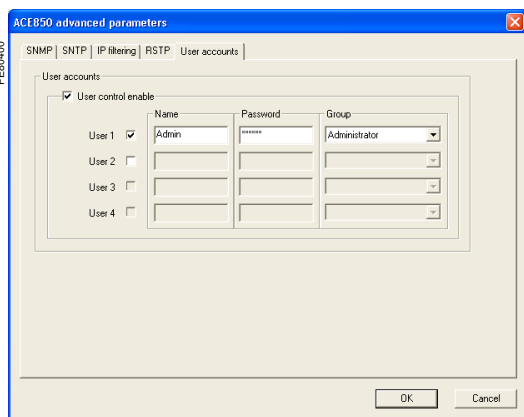

SFT2841: User accounts configuration.

User accounts configuration

ACE850 users are assigned usernames and passwords used to gain access to the FTP or WEB servers. Each user belongs to a group which determines the user's access rights:

- Administrator: read-write access to the FTP server, access to the WEB server
- Operator: read-only access to the FTP server, access to the WEB server
- Guest: no access to the FTP server, access to the WEB server

Up to 4 user accounts can be defined.

Parameters	Description	Authorized values
User control enable	Check this box to enable the configuration of users account. Currently, the ACE850 will not operate if this box is not checked. Ensure that this box is always checked.	Default: enabled
User n	Check this box to create this user account. Uncheck it to delete the account (only the last account in the list can be deleted).	Default: user 1 enabled Users 2 to 4 disabled
Name	User name	String (1 to 8 characters)
Password	User password	String (4 to 8 characters)
Group	Group to which the user belongs	Administrator, Operator, Guest

The following account is always created by default as user 1:

- Name: Admin
- Password: ACE850
- Group: Administrator

IP address and parameter guidelines

IP addresses

Several configuration parameters are IP addresses. These addresses must follow precise rules which are enforced by SFT2841 and ACE850. These rules are:

- Every IP address is made of 4 fields separated by dots: x . y . z . t
- Each field is a decimal value coded on 8 bits (range [0..255]).
- The first field (x) must be in the range [1..224] but must not be 127.
- Intermediate fields can cover the full range [0..255].
- The last field must not be 0 (range [1..255]).

IP subnet mask

The IP subnet mask is also made of 4 dot separated fields:

- The binary representation of the subnet mask is made of a set of 8 to 30 contiguous ones in the most significant part, followed by a set of contiguous zeroes (255.0.0.0 to 255.255.255.252).
- For a class A IP address ($x \leq 126$), the number of ones in the subnet mask must be at least 8 (255.y.z.t).
- For a class B IP address ($128 \leq x \leq 191$), the number of ones in the subnet mask must be at least 16 (255.255.z.t).
- For a class C IP address ($192 \leq x \leq 223$), the number of ones in the subnet mask must be at least 24 (255.255.255.t).
- The subnet part of the device IP address, obtained when applying the subnet mask, must not be 0.

IP default gateway

- An IP address of 0.0.0.0 means no gateway.
- If a gateway is defined, it must belong to the same subnet as the device.

Installing the communication network

Preliminary study

The communication network must first be the subject of a technical study to determine the following, according to the installation characteristics and constraints (geography, amount of information processed, etc.):

- the type of medium (electrical or fiber optic)
- the number of Sepam units per network
- the transmission speed
- the ACE interfaces configuration
- the Sepam parameter settings.

Sepam user manual

The communication interfaces must be installed and connected in accordance with the instructions in the Installation chapter of this manual.

Preliminary checks

The following preliminary checks must be made:

- check the CCA612 cord connection between the ACE interface and the Sepam base unit
- check the ACE Modbus communication port connection
- check the complete configuration of the ACE
- for the ACE969, check the auxiliary power supply connection.

Checking the operation of the ACE interface

You can use the following to check that an ACE interface is operating correctly:

- the indicator LEDs on the front panel of the ACE
- the information provided by the SFT2841 software connected to Sepam:
 - on the Diagnosis screen
 - on the Communication configuration screens.

Link activity LED for ACE949-2, ACE959 and ACE937

The link activity LED for ACE949-2, ACE959 and ACE937 interfaces flashes when Sepam transmission or reception is active.

Indicator LEDs on the ACE969

- green "on" LED: ACE969 energized
- red "key" LED: ACE969 interface status
 - LED off: ACE969 configured and communication operational
 - LED flashing: ACE969 configuration error or ACE969 not configured
 - LED on: ACE969 error
- link activity LED: S-LAN Tx flashing, Sepam transmission active
- link activity LED: S-LAN Rx flashing, Sepam reception active.

Diagnosis using SFT2841 software

Sepam diagnosis screen

When connected to Sepam, the SFT2841 software informs the operator of the general Sepam status and of the Sepam communication status in particular. All Sepam status information appears on the Sepam diagnosis screen.

Sepam communication diagnosis

The operator is provided with the following information to assist with identifying and resolving communication problems:

- name of the protocol configured
- Modbus interface version number
- number of valid frames received (CPT9)
- number of invalid (mistaken) frames received (CPT2).

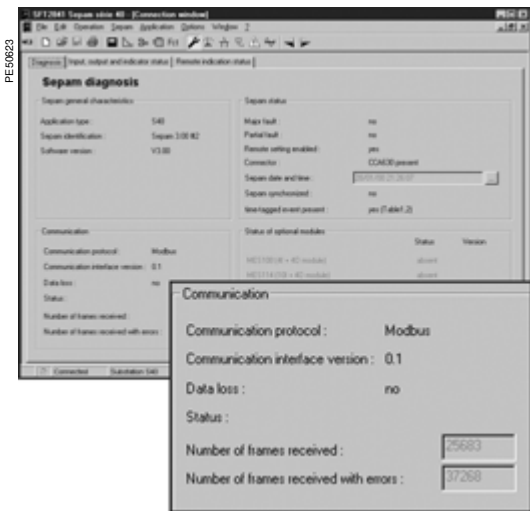

SFT2841: Sepam series 40 diagnosis screen.

Link activity LED

The ACE interface link activity LEDs are activated by variations in the signal on the Modbus network. When the supervisor communicates with Sepam (during transmission or reception), these LEDs flash. After wiring, check the information given by the link activity LEDs when the supervisor operates.

Note: Flashing indicates that there is traffic passing to or from Sepam; it does not mean that the exchanges are valid.

Functional test

If there is any doubt about correct operation of the link:

- run read/write cycles in the test zone
- use Modbus diagnosis function 8 (sub-code 0, echo mode).

The Modbus frames below, transmitted or received by a supervisor, are an example of a test performed when communication is set up.

Test zone	
Read	
Transmission	01 03 0C00 0002 C75B
Reception	01 03 04 0000 0000 FA33
Write	
Transmission	01 10 0C00 0001 02 1234 6727
Reception	01 10 0C00 0001 0299
Read	
Transmission	01 03 0C00 0001 875A
Reception	01 03 02 1234 B533
Function 8 - Modbus diagnosis, echo mode	
Transmission	01 08 0000 1234 ED7C
Reception	01 08 0000 1234 ED7C

Even in echo mode, Sepam recalculates and checks the CRC sent by the master:

- if the CRC received is valid, Sepam replies
- if the CRC received is invalid, Sepam does not reply.

Modbus diagnosis counters

Counter definition

Sepam manages the Modbus diagnosis counters. These are:

- **CPT1:** Number of valid frames received, whether the slave is involved or not
- **CPT2:** Number of frames received with a CRC error or physical error (frames with more than 255 bytes, frames received with at least one parity, overrun, framing or line-break error)
- In the 2-wire RS 485 mode, the counter must not be taken into account (meaningless).
- **CPT3:** Number of exception responses generated (even if not transmitted, due to receipt of a broadcast request)
- **CPT4:** Number of frames specifically addressed to the station (excluding broadcasting)
- **CPT5:** Number of valid broadcast frames received
- **CPT6:** Not significant
- **CPT7:** Not significant
- **CPT8:** Number of frames received with at least one character having a physical error (parity, overrun, framing or line break)
- **CPT9:** Number of valid requests received and correctly executed.

Counter reset

The counters are reset to 0:

- when they reach the maximum value FFFFh (65535)
- when they are reset by a Modbus command (function 8)
- when Sepam auxiliary power is lost
- when communication parameters are modified.

Using the counters

Modbus diagnosis counters help to detect and resolve communication problems.

They can be accessed by the dedicated read functions (Modbus protocol functions 8 and 11).

CPT2 and CPT9 counters can be displayed on SFT2841

("Sepam Diagnosis" screen).

An incorrect speed (or parity) increments CPT2.

Non-reception is signaled by the lack of change on CPT9.

Operating anomalies

It is advisable to connect the Sepam units to the Modbus network one by one.

Make sure that the supervisor is sending frames to the relevant Sepam by checking the activity on the RS 232 - RS 485 converter or the fiber-optic converter if there is one, and on the ACE module.

RS 485 network

- check the wiring on each ACE module
- check the tightness of the screw terminals on each ACE module
- check the connection of the CCA612 cord linking the ACE module to the Sepam base unit
- check that polarization is only at one point and that impedance matching is at both ends of the RS 485 network
- check the auxiliary power supply connection to the ACE969TP-2
- check that the ACE909-2 or ACE919 converter used is connected, powered and set up correctly.

Fiber-optic network

- check the connections on the ACE module
- check the connection of the CCA612 cord linking the ACE module to the Sepam base unit
- check the auxiliary power supply connection to the ACE969FO-2
- check that the converter or fiber-optic star used is connected, powered and set up correctly
- for a fiber-optic ring, check that the Modbus master can handle the echo of its requests correctly.

In all cases

- check all the ACE configuration parameters on SFT2841
- check the CPT2 and CPT9 diagnostic counters on the SFT2841 ("Sepam Diagnosis" screen).

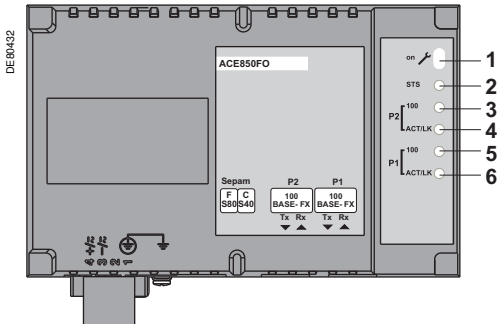

ACE850 communication interface.

Installing the Ethernet network

Preliminary study

According to the installation characteristics and constraints, a technical study must first determine the Ethernet network requirements, including:

- the network topology
- the various subnets (if any) and their interconnections
- the IP addressing scheme

Sepam operating instructions

Communication interfaces must be installed and connected in accordance with the instructions given in this manual page 244. See also the ACE850 installation guide delivered with each ACE850, reference BBV35290.

Preliminary checks

Perform the following actions:

- check the CCA614 cord connection between the ACE850 interface and the Sepam base unit
- check the connection of the ACE850 to the Ethernet network
- check the auxiliary power supply connection
- check the complete configuration of the ACE850.

Checking the operation of the ACE interface

You can use the following to check that an ACE850 interface is operating correctly:

- the indicator LEDs on the front panel of the ACE850
- the information provided by the SFT2841 software connected to Sepam
- the Web pages embedded inside the ACE850.

Basic diagnostics

Diagnosis using indicator LEDs on the ACE850

1 On/fault indicator. This indicator has the following states:

- Off: the module is not powered
- steady red: the ACE850 is initializing or is faulty
- blinking red: the ACE850 is unable to establish communication with the Sepam base unit, or the ACE850 is not properly configured
- steady green: the ACE850 is operating correctly
- fast blinking green: indicates a transient state which occurs at startup when IEC 61850 communication is also used
- steady green and blinking red: communication with the base unit has been lost. This can indicate a normal situation due to a restart of the Sepam after parameters have been downloaded. The ACE850 automatically resumes normal operation in a few seconds.

This status can also indicate an error condition, in which case, ACE850 restarts automatically within 15 seconds and try to re-establish connection.

2 Status indicator. This indicator has the following states:

- Off: the Ethernet communication is not started
- steady green: the Ethernet communication is correctly operating
- three blinks pattern: no logical Ethernet link
- four blinks pattern: duplicate IP address
- six blinks pattern: invalid IP configuration.

3 and 5 Speed indicators. These indicators have the following states:

- Off: the corresponding physical link is down or the port speed is 10Mbps
- On: the corresponding port operates at 100Mbps.

4 and 6 Link/Activity indicators. These indicators have the following states:

- Off: the corresponding physical link is not established
- On: the corresponding physical link is established
- blinking: the indicator blinks with the activity on the link.

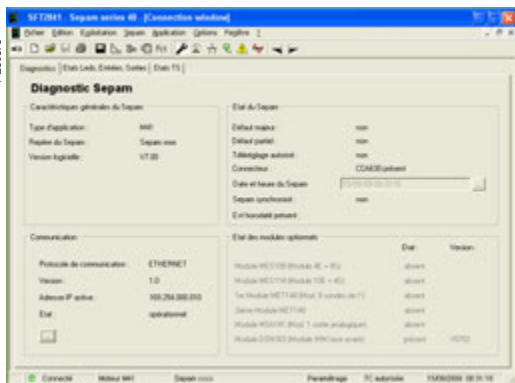

SFT2841: Sepam diagnosis screen.

Diagnosis using SFT2841 software

When connected to Sepam, the SFT2841 software informs the operator of the general Sepam status and of the Sepam communication status in particular. Sepam status information appears on the Sepam diagnosis screen on which buttons can be used to obtain detailed status information on each communication channel. The Sepam diagnosis screen can be used to check that the Sepam base unit and the ACE850 interface are correctly connected:

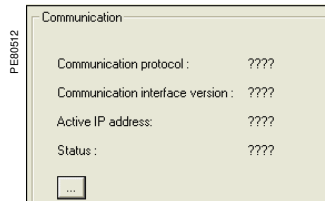

Diagnosis screen detail:
ACE850 not or improperly connected.

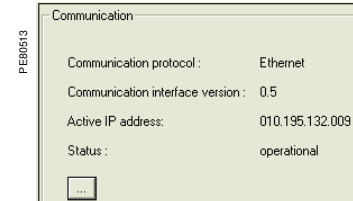

Diagnosis screen detail:
ACE850 connected properly.

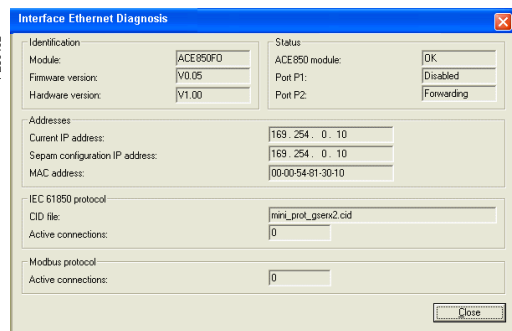

SFT2841: Ethernet diagnosis screen.

The Ethernet diagnosis screen can be used to check:

- the ACE850 module status. The ACE850 status is OK if the ACE850 validates its configuration.
- the communication ports status
- the current ACE850 IP address. If the current IP address is different from the one configured, this could mean that the configured address is not valid, unless the IEC 61850 protocol is also being used.



ACE850 home page.

Advanced diagnostics using the embedded Web server

The advanced diagnostics feature is only available when it is possible to establish an Ethernet connection with the ACE850. If not, the basic diagnostics must be used to solve the problems.

Accessing the ACE850 Web server

1. Start your web browser (Internet explorer 6.0 or higher, Mozilla Firefox for example).
2. In the address text box, type the address of the ACE850 (169.254.0.10 is the default), then press **Enter**.
3. In the login window, type your username and password (default is Admin, ACE850).
4. From the left side menu, choose the language for the current session.
5. From the menu, click **Diagnostics** to access the diagnostics menu.

Diagnostics Web pages

There are two general diagnostics pages dealing with Ethernet operation:

- Ethernet global statistics
 - Ethernet port statistics
- There is also a set of protocol dedicated diagnostic pages:
- Modbus statistics
 - IEC 61850 statistics (not covered in this manual)
 - SNMP statistics
 - Sntp statistics
 - RSTP statistics

Diagnostic pages are automatically refreshed every 5 seconds (approximately).

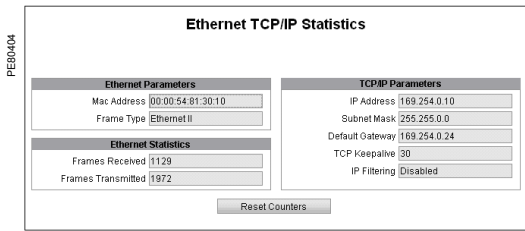

ACE850 Ethernet TCP/IP statistics.

Ethernet TCP/IP statistics

Item	Description
Mac address	Unique Ethernet hardware address of the ACE850
Frame type	Value of the frame type configured with SFT2841
TCP/IP parameters	Parameter values configured with SFT2841
Frames received	Total number of received Ethernet frames, regardless of port or protocol
Frames transmitted	Total number of transmitted Ethernet frames, regardless of port or protocol
Reset Counters button	Button to reset the Ethernet counters

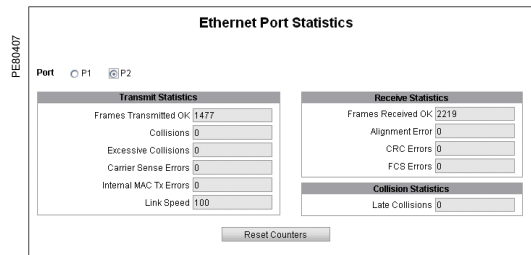

ACE850 Ethernet port statistics.

Ethernet port statistics

Item	Description
Port P1/P2 buttons	Selection of the port of which statistics are displayed
Frames transmitted OK	A counter that increments each time a frame is successfully transmitted.
Collisions	A counter that increments each time a frame is retransmitted due to collision detection.
Excessive collisions	A counter that increments each time a frame cannot be sent because it has reached the maximum collision status based on the Truncated Binary Exponential Backoff algorithm.
Carrier sense errors	A counter that increments each time there is a collision because carrier sense is disabled.
Internal MAC Tx errors	A counter that increments for every transmission error that is not caused by late, excessive, or carrier sense collisions.
Link speed	Actual link speed
Frames received OK	A counter that increments each time a frame is successfully received.
Alignment errors	A counter that increments each time a received frame has an FCS error and does not end on an 8-bit frame boundary.
CRC errors	A counter that increments each time a received frame has a CRC or an alignment error.
FCS errors	A counter that increments each time a received frame has a FCS or an alignment error.
Late collisions	A counter that increments each time a collision occurs after the slot time (512 bits starting at the preamble).
Reset counters button	Button to reset the port counters

PEB0408

Modbus/TCP Server Statistics

TCP Connection

Port Status: Operational

Inbound/Outbound Statistics

Opened TCP Connections: 1

Received Messages: 24

Transmitted Messages: 25

Reset Counters

ACE850 Modbus/TCP server statistics.

PEB0409

Modbus/TCP Connections Statistics

Connections						
Index	Remote IP	Remote Port	Local Port	Transmitted Messages	Received Messages	Sent Errors
1	169.254.0.20	4607	502	15801	15802	0
2	169.254.0.20	3213	502	3	3	2

Reset Counters

ACE850 Modbus/TCP connections statistics.

PEB0410

SNMP Statistics

Global Diagnostics

SNMP Agent Status: Operational

Bad Community Usages: 13

Received Messages: 342

Transmitted Messages: 342

Reset Counters

ACE850 SNMP statistics.

Modbus/TCP server statistics

Item	Description
Port status	Modbus port status
Opened TCP connections	Number of Modbus clients currently connected
Received messages	Total number of Modbus requests
Transmitted messages	Total number of Modbus responses
Reset counters button	Button to reset the messages counters

Note: the Web interface uses one Modbus connection to operate.

Modbus/TCP connections statistics

Item	Description
Index	Connection number
Remote IP	IP address of the Modbus client
Remote port	TCP port number on the client side
Local port	TCP port number on the server side
Transmitted messages	Number of Modbus requests for this connection
Received messages	Number of Modbus normal responses for this connection
Sent errors	Number of Modbus exception responses for this connection
Reset counters button	Button to reset the messages counters

SNMP statistics

Item	Description
SNMP agent status	Status of the SNMP agent
Bad Community usages	Number of requests with invalid community
Received messages	Total number of SNMP requests
Transmitted messages	Total number of SNMP responses
Reset counters button	Button to reset the messages counters

PER0411

SNTP Statistics

SNTP Protocol	
SNTP Client Status	Enabled
Active SNTP Server IP Address	169.254.0.20
Poll Interval (minutes)	1
Round Trip Delay	0,002
Local Offset	0,003

Date and Time	
Daylight Saving Time	Enabled
Last Successful Time Sync (UTC)	2009-04-22 08:58:13:210
Device Date and Time (UTC)	2009-04-22 08:59:07:114
Device Date and Time (local)	2009-04-22 10:29:07:114

ACE850 SNTP statistics.

SNTP statistics

Item	Description
SNTP Client status	Value configured for the parameter in SFT2841
Active SNTP server IP address	Address of the server currently answering SNTP requests (0.0.0.0 if no server answer)
Poll interval	Value configured for the parameter in SFT2841
Round trip delay	Total time for SNMP request and response messages
Local offset	Difference between SNTP time and ACE time
Daylight saving time	Value configured for the parameter in SFT2841
Last Successful Time Synchronization (UTC)	Last time the ACE850 successfully contacted the SNTP server (UTC time)
Device Date and Time (UTC)	Current time and date of the ACE850 (UTC time)
Device Date and Time (local)	Current time and date of the ACE850 (local time)

PER0412

RSTP Bridge Statistics

General	
Bridge Status	Enabled
Bridge ID	61440 / 00:00:54:90:60:02
Designated Root ID	8192 / 00:0A:DC:19:AE:40
Designated Root Port	128 / 0
Rootpath Cost	200000
Total Topology Changes	3

Configured vs Learned	
Configured Hello Time	2
Learned Hello Time	2
Configured Forward Delay	15
Learned Forward Delay	15
Configured Max Age	20
Learned Max Age	20

ACE850 RSTP bridge statistics.

RSTP bridge statistics

Item	Description
Bridge status	RSTP status of the bridge
Bridge ID	Bridge vector (Bridge priority/Bridge Mac address)
Designated Root ID	Bridge vector of the RSTP root bridge
Designated Root Port	Identifier of the root port (priority/number)
Rootpath cost	Path cost to the root
Total topology changes	Topology change counter (as defined by 802.1D-2004)
Configured hello time	Value of the configured hello time
Learned hello time	Operational value for hello time
Configured forward delay	Reminder of the configured forward delay
Learned forward delay	Operational value for forward delay
Configured max age	Value of the configured max age
Learned max age	Operational value for max age

FEB0413

RSTP Port Statistics

Port P1 P2

Port Status	
Status	Forwarding
Role	Root
Priority	128
Port Path Cost	200000
Designated Port ID	128 / 15
Received RSTs	32824
Transmitted RSTs	3
Received Configure	0
Transmitted Configure	0
Received TCNs	0
Transmitted TCNs	0

ACE850 RSTP port statistics.

RSTP port statistics

Item	Description
Port P1 / P2 buttons	Selection of the port of which statistics are displayed
Status	RSTP status for the selected port
Role	RSTP role for the selected port
Priority	Port priority
Port path cost	Port contribution to root path cost
Designated port ID	Identifier of the link partner port (priority/number)
Received RSTs	Number of RST BPDUs received (RSTP)
Transmitted RSTs	Number of RST BPDUs sent (RSTP)
Received configure	Number of Configuration BPDUs received (STP)
Transmitted configure	Number of Configuration BPDUs sent (STP)
Received TCNs	Number of Topology change BPDUs received (STP)
Transmitted TCNs	Number of Topology change BPDUs sent (STP)

Presentation

Data which are similar from the monitoring and control application viewpoint are grouped together in adjacent address zones:

NOTICE
<p>RISK OF DATA CORRUPTION</p> <p>When using an ACE850 communication interface with IEC 61850 communication enabled, do not use the following address zones:</p> <ul style="list-style-type: none"> ■ Event table 1 (0040-0060), ■ Protections settings zone 1 (1E00-1F7C), ■ Disturbance recording zone 1 (2200-237C). <p>Failure to follow these instructions can result in equipment damage.</p>

	Hexadecimal starting address	Ending address	Modbus functions enabled
Synchronization zone	0002	0005	3, 16
Identification zone	0006	000F	3
Event table 1			
Exchange word	0040	0040	3, 6, 16
Events (1 to 4)	0041	0060	3
Event table 2			
Exchange word	0070	0070	3, 6, 16
Events (1 to 4)	0071	0090	3
Data			
Remote control orders	00F0	00F0	3, 4, 6, 16
	00F2	00F2	1, 2, 5, 15 ⁽¹⁾
Remote control selection	00F1	00F1	3, 4, 6, 16
	00F3	00F3	1, 2, 5, 15 ⁽¹⁾
Status	0100	0112	3, 4 1, 2 ⁽¹⁾
Measurements	0113	0158	3, 4
Diagnosis	0159	0185	3, 4
Phase displacement	01A0	01A9	3, 4
Tripping context	0250	027F	3, 4
Switchgear diagnosis	0290	02A5	3, 4
Application	02CC	02FE	3
Test zone	0C00	0C0F	3, 4, 6, 16 1, 2, 5, 15
Protection settings zone 1			
Read settings	1E00	1E7C	3
Read request	1E80	1E80	3, 6, 16
Remote settings	1F00	1F7C	3, 6
Protection settings zone 2			
Read settings	2000	207C	3
Read request	2080	2080	3, 6, 16
Remote settings	2100	217C	3, 16
Disturbance recording zone 1			
Record selection	2200	2203	3, 16
Identification zone	2204	2271	3
Disturb. rec. exchange word	2300	2300	3, 6, 16
Disturbance recording data	2301	237C	3
Disturbance recording zone 2			
Record selection	2400	2403	3, 16
Identification zone	2404	2471	3
Disturb. rec. exchange word	2500	2500	3, 6, 16
Disturbance recording data	2501	257C	3
S-LAN communication monitoring			
Time delay	5815	5815	3, 16 ⁽²⁾

Note: non-addressable zones may reply by an exception message or else supply non-significant data.

(1) Zones accessible in word mode or bit mode.

The address of bit i ($0 \leq i \leq F$) of address word J is then $(J \times 16) + i$.

Example: 0C00 bit 0 = C000 0C00 bit 7 = C007.

(2) Range allowed: 10 to 65535 x 100 ms (Time delay can be set from 1 to 6553.5 s with increments of 0.1 s).

Data encoding

For all formats

If a measurement overruns the maximum permissible value for the related format, the value read for the measurement will be the maximum permissible value for the format.

16NS format

The information is encoded in a 16-bit word, in binary format, absolute value (unsigned). The 0 bit (b0) is the least significant bit in the word.

16S format signed measurements (temperatures,...)

The information is encoded in a 16-bit word as a complement of 2.

Example:

- 0001 represents +1
- FFFF represents -1.

32NS or 2 x 16NS format

The information is encoded in two 16-bit words, in binary format, unsigned. The first word is the most significant word.

32S format

The information is encoded as a complement of 2 in 2 words. The first word is the most significant word:

- 0000, 0001 represents +1
- FFFF, FFFF represents -1.

B format

Rank i bit in the word, with i between 0 and F.

Examples		F	E	D	C	B	A	9	8	7	6	5	4	3	2	1	0
TS1 to TS16	Word address 0101 Bit address 101x	16	15	14	13	12	11	10	9	8	7	6	5	4	3	2	1
TS49 to TS64	Word address 0104 Bit address 104x	64	63	62	61	60	59	58	57	56	55	54	53	52	51	50	49
TC1 to TC16	Word address 00F0 Bit address 0F0x	16	15	14	13	12	11	10	9	8	7	6	5	4	3	2	1
STC1 to STC16	Word address 00F1 Bit address 0F1x	16	15	14	13	12	11	10	9	8	7	6	5	4	3	2	1

X format: Sepam check-word

This format applies only to the Sepam check-word that may be accessed at the word address 0100h. This word contains various items of information relating to:

- Sepam operating mode
 - time-tagging of events.
- Each data item contained in the Sepam check-word may be accessed bit by bit, from address **1000** for bit 0 to **100F** for bit 15.
- bit 15 : event present in event zone 1
 - bit 14 : Sepam in "data loss" status in event zone 1
 - bit 13 : Sepam not synchronous
 - bit 12 : Sepam time not correct
 - bit 11 : presence of events in event zone 2
 - bit 10 : Sepam in "data loss" status in event zone 2
 - bit 9 : major fault in Sepam
 - bit 8 : partial fault in Sepam
 - bit 7 : setting group A in service
 - bit 6 : setting group B in service
 - bit 1 : Sepam in local setting mode
 - other bits reserved (undetermined values).

Status changes of bits 1, 6, 7, 8, 10, 12, 13 and 14 of this word trigger the sending of a time-tagged event.

Synchronization zone

The **synchronization zone** is a table which contains the absolute date and time for the time-tagging function. Time messages should be written in a single block containing 4 words, using function 16: write word.

Messages can be read word by word or by groups of words using function 3.

Synchronization zone	Word address	Access	Modbus function enabled
Binary time (year)	0002	Read/write	3, 16
Binary time (months + days)	0003	Read	3
Binary time (hours + minutes)	0004	Read	3
Binary time (milliseconds)	0005	Read	3

See "time-tagging of events" chapter for data format.

Identification zone

The **identification zone** contains system-type information pertaining to the identification of the Sepam equipment.

Some of the information in the identification zone is also found in the configuration zone at the address 02CCh.

Identification zone	Word address	Access	Modbus function enabled	Format	Value
Manufacturer identification	0006	R	3		0100
Equipment identification	0007	R	3		0
Marking + equipment type	0008	R	3		Idem 02E2
Modbus version	0009	R	3	Not managed	0
Application version	000A/B	R	3	(1)	
Sepam check-word	000C	R	3		Idem 0100
Extension word	000D	R	3	Not managed	0
Command	000E	R/W	3/16	Not managed	Init. to 0
Extension address	000F	R	3		02CC

(1) MSB word 2: major index
LSB word 2: minor index.

Events 1 zone

The **event zone** is a table which contains a maximum of 4 time-tagged events.

Events should be read in a single block containing 33 words using function 3.

The exchange word can be written using functions 6 or 16, and read individually using function 3.

Events 1 zone	Word address	Access	Modbus function enabled
Exchange word	0040	Read/write	3, 6, 16
Event n°1	0041-0048	Read	3
Event n°2	0049-0050	Read	3
Event n°3	0051-0058	Read	3
Event n°4	0059-0060	Read	3

See "time-tagging of events" chapter for data format.

Events 2 zone

The **event zone** is a table which contains a maximum of 4 time-tagged events.

Events should be read in a single block containing 33 words using function 3.

The exchange word can be written using functions 6 or 16 and read individually using function 3.

Events 2 zone	Word address	Access	Modbus function enabled
Exchange word	0070	Read/write	3, 6, 16
Event n°1	0071-0078	Read	3
Event n°2	0079-0080	Read	3
Event n°3	0081-0088	Read	3
Event n°4	0089-0090	Read	3

See "time-tagging of events" chapter for data format.

Remote control zone

The **remote control zone** is a table which contains the pre-assigned remote control bits (TC). The zone may be read or written using the word functions or bit functions. The use of remote control orders is discussed in detail on page 172.

Remote control orders	Word address	Bit address	Access	Function	Format
TC1-TC16	00F0	0F00	R/W	3/4/6/16 1/2/5/15	B
STC1-STC16	00F1	0F10	R/W	3/4/6/16 1/2/5/15	B
TC17-TC32	00F2	0F20	R/W	3/4/6/16 1/2/5/15	B
STC17-STC32	00F3	0F30	R/W	3/4/6/16 1/2/5/15	B

Status zone

The **status zone** is a table that contains the Sepam check-word, pre-assigned remote indication bits (TS), logic inputs, logic equation bits, logic outputs, LEDs and analog output control word.

The TS assignments are discussed in detail on page 169.

Status	Word address	Bit address	Access	Modbus function enabled	Format
Sepam check-word	0100	1000	R	3/4 or 1, 2, 7	X
TS1-TS16	0101	1010	R	3/4 or 1, 2	B
TS17-TS32	0102	1020	R	3/4 or 1, 2	B
TS33-TS48	0103	1030	R	3/4 or 1, 2	B
TS49-TS64 (reserved)	0104	1040	R	3/4 or 1, 2	B
TS65-TS80	0105	1050	R	3/4 or 1, 2	B
TS81-TS96	0106	1060	R	3/4 or 1, 2	B
TS97-TS112	0107	1070	R	3/4 or 1, 2	B
TS113-TS128	0108	1080	R	3/4 or 1, 2	B
TS129-TS144	0109	1090	R	3/4 or 1, 2	B
Reserved	010A	10A0	-	-	-
Logic inputs	010B	10B0	R	3/4 or 1, 2	B
Logic equation bits	010C	10C0	R	3/4 or 1, 2	B
Logic outputs	010D	10D0	R	3/4 or 1, 2	B
LEDs	010E	10E0	R	3/4 or 1, 2	B
Analog output	010F	10F0	R/W	3, 6, 16	16S

Address word 010B: logic input status (bit address 10B0 to 10BF)

Bit	F	E	D	C	B	A	9	8	7	6	5	4	3	2	1	0
Inputs	-	-	-	-	-	-	I26	I25	I24	I23	I22	I21	I14	I13	I12	I11

Address word 010C: logic equation bit status (bit address 10C0 to 10CF)

Bit	7	6	5	4	3	2	1	0
Equation	V8	V7	V6	V5	V4	V3	V2	V1

Bit	F	E	D	C	B	A	9	8
Equation	-	-	V_FLAGREC	V_INHIBCLOSE	V_CLOSECB	V_TRIPCB	V10	V9

Address word 010D: logic output status (bit address 10D0 to 10DF)

Bit	F	E	D	C	B	A	9	8	7	6	5	4	3	2	1	0
Output	-	-	-	-	-	-	-	-	O14	O13	O12	O11	O4	O3	O2	O1

Address word 010E: LED status (bit address 10E0 à 10EF)

Bit	F	E	D	C	B	A	9	8	7	6	5	4	3	2	1	0
LED	-	-	-	-	-	-	L9	L8	L7	L6	L5	L4	L3	L2	L1	LD

LD: red LED indicating Sepam unavailable.

Measurement zone x 1

Measurements x 1	Word address	Access	Modbus function enabled	Format	Unit
Phase current I1 (x 1)	0113	R	3, 4	16NS	0.1 A
Phase current I2 (x 1)	0114	R	3, 4	16NS	0.1 A
Phase current I3 (x 1)	0115	R	3, 4	16NS	0.1 A
Residual current I0 Sum (x 1)	0116	R	3, 4	16NS	0.1 A
Residual current measured (x 1)	0117	R	3, 4	16NS	0.1 A
Average phase current Im1 (x 1)	0118	R	3, 4	16NS	0.1 A
Average phase current Im2 (x 1)	0119	R	3, 4	16NS	0.1 A
Average phase current Im3 (x 1)	011A	R	3, 4	16NS	0.1 A
Peak demand phase current IM1 (x 1)	011B	R	3, 4	16NS	0.1 A
Peak demand phase current IM2 (x 1)	011C	R	3, 4	16NS	0.1 A
Peak demand phase current IM3 (x 1)	011D	R	3, 4	16NS	0.1 A
Phase-to-phase voltage U21 (x 1)	011E	R	3, 4	16NS	1 V
Phase-to-phase voltage U32 (x 1)	011F	R	3, 4	16NS	1 V
Phase-to-phase voltage U13 (x 1)	0120	R	3, 4	16NS	1 V
Phase-to-neutral voltage V1 (x 1)	0121	R	3, 4	16NS	1 V
Phase-to-neutral voltage V2 (x 1)	0122	R	3, 4	16NS	1 V
Phase-to-neutral voltage V3 (x 1)	0123	R	3, 4	16NS	1 V
Residual voltage V0 (x 1)	0124	R	3, 4	16NS	1 V
Positive sequence voltage Vd (x 1)	0125	R	3, 4	16NS	1 V
Negative sequence voltage Vi (x 1)	0126	R	3, 4	16NS	1 V
Frequency	0127	R	3, 4	16NS	0.01 Hz
Active power P (x 1)	0128	R	3, 4	16S	1 kW
Reactive power Q (x 1)	0129	R	3, 4	16S	1 kvar
Apparent power S (x 1)	012A	R	3, 4	16S	1 kVA
Peak demand active power Pm (x 1)	012B	R	3, 4	16S	1 kW
Peak demand reactive power Qm (x 1)	012C	R	3, 4	16S	1 kvar
Power factor cos φ (x 100)	012D	R	3, 4	16S	0.01
Positive active energy Ea+ (x 1)	012E/012F	R	3, 4	2 x 16NS	100 kW.h
Negative active energy Ea- (x 1)	0130/0131	R	3, 4	2 x 16NS	100 kW.h
Positive reactive energy Er+ (x 1)	0132/0133	R	3, 4	2 x 16NS	100 kvar.h
Negative reactive energy Er- (x 1)	0134/0135	R	3, 4	2 x 16NS	100 kvar.h

Measurement zone x 10

Measurements x 10	Word address	Access	Modbus function enabled	Format	Unit
Phase current I1 (x 10)	0136	R	3, 4	16NS	1 A
Phase current I2 (x 10)	0137	R	3, 4	16NS	1 A
Phase current I3 (x 10)	0138	R	3, 4	16NS	1 A
Residual current I0 Sum (x 10)	0139	R	3, 4	16NS	1 A
Residual current measured (x 10)	013A	R	3, 4	16NS	1 A
Average phase current Im1 (x 10)	013B	R	3, 4	16NS	1 A
Average phase current Im2 (x 10)	013C	R	3, 4	16NS	1 A
Average phase current Im3 (x 10)	013D	R	3, 4	16NS	1 A
Peak demand phase current IM1 (x 10)	013E	R	3, 4	16NS	1 A
Peak demand phase current IM2 (x 10)	013F	R	3, 4	16NS	1 A
Peak demand phase current IM3 (x 10)	0140	R	3, 4	16NS	1 A
Phase-to-phase voltage U21 (x 10)	0141	R	3, 4	16NS	10 V
Phase-to-phase voltage U32 (x 10)	0142	R	3, 4	16NS	10 V
Phase-to-phase voltage U13 (x 10)	0143	R	3, 4	16NS	10 V
Phase-to-neutral voltage V1 (x 10)	0144	R	3, 4	16NS	10 V
Phase-to-neutral voltage V2 (x 10)	0145	R	3, 4	16NS	10 V
Phase-to-neutral voltage V3 (x 10)	0146	R	3, 4	16NS	10 V
Residual voltage V0 (x 10)	0147	R	3, 4	16NS	10 V
Positive sequence voltage Vd (x 10)	0148	R	3, 4	16NS	10 V
Negative sequence voltage Vi (x 10)	0149	R	3, 4	16NS	10 V
Frequency	014A	R	3, 4	16NS	0.01 Hz
Active power P (x 100)	014B	R	3, 4	16S	100 kW
Reactive power Q (x 100)	014C	R	3, 4	16S	100 kvar
Apparent power S (x 100)	014D	R	3, 4	16S	100 kVA
Peak demand active power Pm (x 100)	014E	R	3, 4	16S	100 kW
Peak demand reactive power Qm (x 100)	014F	R	3, 4	16S	100 kvar
Power factor cos φ (x 100)	0150	R	3, 4	16S	0.01
Positive active energy Ea+ (x 1)	0151/0152	R	3, 4	2 x 16NS	100 kW.h
Energie active négative Ea- (x 1)	0153/0154	R	3, 4	2 x 16NS	100 kW.h
Positive reactive energy Er+ (x 1)	0155/0156	R	3, 4	2 x 16NS	100 kvar.h
Negative reactive energy Er- (x 1)	0157/0158	R	3, 4	2 x 16NS	100 kvar.h

Diagnosis

Diagnosis	Word address	Access	Modbus function enabled	Format	Unit
Peak demand Ii/I _d	0159	L	3, 4	16NS	%
Last tripping current Itrip1	015A	R	3, 4	16NS	10 A
Last tripping current Itrip2	015B	R	3, 4	16NS	10 A
Last tripping current Itrip3	015C	R	3, 4	16NS	10 A
Reserved	015D	-	-	-	-
Cumulative breaking current	015E	R	3, 4	16NS	1(kA) ²
Number of operations	015F	R	3, 4	16NS	1
Operating time	0160	R	3, 4	16NS	1 ms
Charging time	0161	R	3, 4	16NS	1 ms
Running hours counter / operation time	0162	R	3, 4	16NS	1 h
Reserved	0163	-	-	-	-
Thermal capacity used	0164	R	3, 4	16NS	%
Time before tripping	0165	R	3, 4	16NS	1 min
Time before closing	0166	R	3, 4	16NS	1 min
Negative sequence / unbalance	0167	R	3, 4	16NS	% lb
Starting time / overload	0168	R	3, 4	16NS	0.1 s
Starting current / overload	0169	R	3, 4	16NS	1 A
Start inhibit time delay	016A	R	3, 4	16NS	1 min
Number of starts allowed	016B	R	3, 4	16NS	1
Temperatures 1 to 16	016C/017B	R	3, 4	16S	1 °C (1 °F)
External positive active energy Ea+ ext	017C/017D	R	3, 4	32NS	100 kW.h
External negative active energy Ea- ext	017E/017F	R	3, 4	32NS	100 kW.h
External positive reactive energy Er+ ext	0180/0181	R	3, 4	32NS	100 kvar.h
External negative reactive energy Er- ext	0182/0183	R	3, 4	32NS	100 kvar.h
Learnt cooling time constant T2 (49 RMS) thermal rate 1	0184	R	3, 4	16NS	mn
Learnt cooling time constant T2 (49 RMS) thermal rate 2	0185	R	3, 4	16NS	mn

Phase displacement zone

Phase displacement	Word address	Access	Modbus function enabled	Format	Unit
Phase displacement $\varphi_{0\Sigma}$	01A0/01A1	L	3, 4	32NS	1°
Phase displacement φ_0	01A2/01A3	L	3, 4	32NS	1°
Phase displacement φ_1	01A4/01A5	L	3, 4	32NS	1°
Phase displacement φ_2	01A6/01A7	L	3, 4	32NS	1°
Phase displacement φ_3	01A8/01A9	L	3, 4	32NS	1°

Tripping context zone

Latest tripping context	Word address Modbus	Access	Modbus function enabled	Format	Unit
Time-tagging of the context (see "time-tagging of events" chapter, page 173)	0250/0253	R	3	IEC	-
Tripping current Itrip1	0254	R	3, 4	32NS	0.1 A
Tripping current Itrip2	0256	R	3, 4	32NS	0.1 A
Tripping current Itrip3	0258	R	3, 4	32NS	0.1 A
Residual current I0 Sum	025A	R	3, 4	32NS	0.1 A
Residual current I0 measured	025C	R	3, 4	32NS	0.1 A
Phase-to-phase voltage U21	025E	R	3, 4	32NS	1 V
Phase-to-phase voltage U32	0260	R	3, 4	32NS	1 V
Phase-to-phase voltage U13	0262	R	3, 4	32NS	1 V
Phase-to-neutral voltage V1	0264	R	3, 4	32NS	1 V
Phase-to-neutral voltage V2	0266	R	3, 4	32NS	1 V
Phase-to-neutral voltage V3	0268	R	3, 4	32NS	1 V
Residual voltage V0	026A	R	3, 4	32NS	1 V
Positive sequence voltage Vd	026C	R	3, 4	32NS	1 V
Negative sequence voltage Vi	026E	R	3, 4	32NS	1 V
Frequency	0270	R	3, 4	32NS	0.01 Hz
Active power P	0272	R	3, 4	32S	1 kW
Reactive power Q	0274	R	3, 4	32S	1 kvar
Negative-sequence current Ii	0276	R	3, 4	32NS	0.1 A
Positive-sequence current Id	0278	R	3, 4	32NS	0.1 A
Faulty phase (s)	027A	R	3, 4	32NS	(1)
Fault location	027C	R	3, 4	32NS	m
Fault resistance	027E	R	3, 4	32NS	mΩ

(1) bit 0 = faulty phase 1
bit 1 = faulty phase 2
bit 2 = faulty phase 3

Switchgear diagnosis zone

Switchgear diagnosis	Word address	Access	Modbus function enabled	Format	Unit
Initial value of cumulative breaking current	0290	R	3, 4	32NS	1 kA ²
Cumulative breaking current (0 < I < 2 In)	0292	R	3, 4	32NS	1 kA ²
Cumulative breaking current (2 In < I < 5 In)	0294	R	3, 4	32NS	1 kA ²
Cumulative breaking current (5 In < I < 10 In)	0296	R	3, 4	32NS	1 kA ²
Cumulative breaking current (10 In < I < 40 In)	0298	R	3, 4	32NS	1 kA ²
Cumulative breaking current (I > 40 In)	029A	R	3, 4	32NS	1 kA ²
Cumulative breaking current	029C	R	3, 4	32NS	1 kA ²
Reserved	029E	-	-	-	-
Number of operations (If MES114)	02A0	R	3, 4	32NS	1
Operating time (With MES114)	02A2	R	3, 4	32NS	1 ms
Charging time (With MES114)	02A4	R	3, 4	32NS	1 ms

Configuration and application zone

Configuration and application	Word address	Access	Modbus function enabled	Format	Unit
Type of application ⁽¹⁾	02CC	R	3	-	-
Name of application (S40, S41, T42...)	02CD/02D2	R	3	ASCII 12c	-
Sepam marking	02D3/02DC	R	3	ASCII 20c	-
Sepam application version	02DD/02DF	R	3	ASCII 6c	-
Modbus address (slave number) for Level 2	02E0	R	3	-	-
Modbus address (slave number) for RHM	02E1	R	3	-	-
Marking + type of equipment ⁽³⁾	02E2	R	3	-	-
Type of coupler (0 = Modbus)	02E3	R	3	-	-
Communication version	02E4	R	3	NG	-
MET148-2 n° 1 module version	02E5/02E7	R	3	ASCII 6c	-
MET148-2 n° 2 module version	02E8/02EA	R	3	ASCII 6c	-
MSA141 module version	02EB/02ED	R	3	ASCII 6c	-
DSM303 module version	02EE/02F0	R	3	ASCII 6c	-
Name of language	02F1/02FA	R	3	ASCII 20c	-
Customized languaged version number ⁽²⁾	02FB	R	3	-	-
English language version number ⁽²⁾	02FC	R	3	-	-
Boot version number ⁽²⁾	02FD	R	3	-	-
Extension word ⁽⁴⁾	02FE	R	3	-	-

(1) 40 : not configured 41 : S40 42 : S41 43 : S42 44 : T40
 45 : T42 46 : M41 47 : G40 60 : S43 61 : S50
 62 : S51 63 : S52 64 : T50 65 : T52 66 : S44
 67 : M40 68 : S54 80 : S53

(2) MSB: major index, LSB: minor index.

(3) 2E2 word: MSB: 11 h (Sepam series 40)
 LSB: hardware configuration.

Bit	7	6	5	4	3	2	1	0
Option	MD/MX	Extension	MET148-2/2	DSM303	MSA141	MET148-2/1	MES114	MES108
Mod.MX	0	z	x	x	x	x	y	y
Mod.MD	1	z	x	0	x	x	y	y

x = 1 if option included

y = 1 if option included, exclusive options

z = 1 if extension in 2FE word ⁽⁴⁾.

(4) Bit 0: = 1 if MES114E or MES114F Vac set up.

Accuracy

Measurement accuracy depends on the weight of the unit; it is equal to the value of the point divided by 2.

Examples:		
U1	Unit = 1 A	Accuracy = 1/2 = 0.5 A
U21	Unit = 10 V	Accuracy = 10/2 = 5 V

Test zone

The **test zone** is a 16-word zone that may be accessed via the communication link by all functions, in both read and write modes, to facilitate communication testing at the time of commissioning or to test the link.

Test zone	Word address	Bit address	Access	Modbus function enabled	Format
Test	0C00	C000-C00F	Read/write	1, 2, 3, 4, 5, 6, 15, 16	None Initialized to 0
	0C0F	C0F0-C0FF	Read/write	1, 2, 3, 4, 5, 6, 15, 16	None Initialized to 0

Protection setting zone

The **protection setting zone** is an exchange table which is used to read and set the protection functions. 2 setting zones are available to be used by 2 masters.

Protection setting	Word address zone 1	Word address zone 2	Access	Modbus function enabled
Setting read buffer	1E00/1E7C	2000/207C	R	3
Setting read request	1E80	2080	R/W	3/6/16
Remote setting request buffer	1F00/1F7C	2100/217C	R/W	3/16

See "Protection settings" chapter.

Fault recorder zone

The **fault recorder zone** is an exchange table which is used to read disturbance recording records. 2 zones are available to be used by 2 masters.

Disturbance recording	Word address zone 1	Word address zone 2	Access	Modbus function enabled
Choice of transfer function	2200/2203	2400/2403	R/W	3/16
Identification zone	2204/2228	2404/2428	R	3
Disturb. rec. exchange zone	2300	2500	R/W	3/6/16
Disturbance recording data	2301/237C	2501/257C	R	3

See "Disturbance recording" chapter.

Use of remote indication bits

Sepam provides the communication link with 144 TS.

The remote indications (TS) are pre-assigned to protection and control functions which depend on the Sepam model.

The TSs may be read using the bit or word functions. Each TS transition is time-tagged and stored in the event stack (see "Time-tagging", page 173).

Address word 0101: TS1 to TS16 (Bit address 1010 to 101F)

TS	Application	S40	S41	S42	S43	S44	T40	T42	M40	M41	G40
		S50	S51	S52	S53	S54	T50	T52			
1	Protection 50/51 unit 1	■	■	■	■	■	■	■	■	■	■
2	Protection 50/51 unit 2	■	■	■	■	■	■	■	■	■	■
3	Protection 50/51 unit 3	■	■	■	■	■	■	■	■	■	■
4	Protection 50/51 unit 4	■	■	■	■	■	■	■	■	■	■
5	Protection 50N/51N unit 1	■	■	■	■	■	■	■	■	■	■
6	Protection 50N/51N unit 2	■	■	■	■	■	■	■	■	■	■
7	Protection 50N/51N unit 3	■	■	■	■	■	■	■	■	■	■
8	Protection 50N/51N unit 4	■	■	■	■	■	■	■	■	■	■
9	Protection 49 RMS alarm set point						■	■	■	■	■
10	Protection 49 RMS tripping set point						■	■	■	■	■
11	Protection 37								■	■	
12	Protection 46 unit 1	■	■	■	■	■	■	■	■	■	■
13	Protection 46 unit 2	■	■	■	■	■	■	■	■	■	■
14	Protection 48/51LR/14 (locked rotor)								■	■	
15	Protection 48/51LR/14 (rotor locking on start)								■	■	
16	Protection 48/51LR/14 (excessive starting time)								■	■	

Address word 0102: TS17 to TS32 (Bit address 1020 to 102F)

TS	Application	S40	S41	S42	S43	S44	T40	T42	M40	M41	G40
		S50	S51	S52	S53	S54	T50	T52			
17	Protection 27D unit 1								■	■	
18	Protection 27D unit 2								■	■	
19	Protection 27/27S unit 1	■	■	■		■	■	■	■	■	■
20	Protection 27/27S unit 2	■	■	■		■	■	■	■	■	■
21	Protection 27R								■	■	
22	Protection 59 unit 1	■	■	■		■	■	■	■	■	■
23	Protection 59 unit 2	■	■	■		■	■	■	■	■	■
24	Protection 59N unit 1	■	■	■		■	■	■	■	■	■
25	Protection 59N unit 2	■	■	■		■	■	■	■	■	■
26	Protection 81H unit 1	■	■	■		■	■	■	■	■	■
27	Protection 81H unit 2	■	■	■		■	■	■	■	■	■
28	Protection 81L unit 1	■	■	■		■	■	■	■	■	■
29	Protection 81L unit 2	■	■	■		■	■	■	■	■	■
30	Protection 81L unit 3	■	■	■		■	■	■	■	■	■
31	Protection 81L unit 4	■	■	■		■	■	■	■	■	■
32	Protection 66								■	■	

Address word 0103: TS33 to TS48 (Bit address 1030 to 103F)

TS	Application	S40	S41	S42	S43	S44	T40	T42	M40	M41	G40
		S50	S51	S52	S53	S54	T50	T52			
33	Protection 67 unit 1			■				■			
34	Protection 67 unit 2							■			
35	Protection 67N unit 1		■	■	■			■		■	
36	Protection 67N unit 2		■	■	■			■		■	
37	Protection 47	■	■	■		■	■	■		■	■
38	Protection 32P		■	■	■					■	■
39	Protection 50BF	■	■	■	■	■	■	■	■	■	■
40	Protection 32Q									■	■
41	Protection 51V										■
42	TC fault	■	■	■	■	■	■	■	■	■	■
43	TP Phase fault	■	■	■	■	■	■	■	■	■	■
44	TP V0 fault	■	■	■	■	■	■	■	■	■	■
45	Reserved										
46	Reserved										
47	Reserved										
48	Reserved										

Address word 0104: TS49 to TS64 (Bit address 1040 to 104F)

TS	Application	S40	S41	S42	S43	S44	T40	T42	M40	M41	G40
		S50	S51	S52	S53	S54	T50	T52			
49	Reserved										
50	Reserved										
51	Reserved										
52	Reserved										
53	Reserved										
54	Reserved										
55	Reserved										
56	Reserved										
57	Reserved										
58	Reserved										
59	Reserved										
60	Reserved										
61	Reserved										
62	Reserved										
63	Reserved										
64	Reserved										

Address word 0105: TS65 to TS80 (Bit address 1050 to 105F)

TS	Application	S40	S41	S42	S43	S44	T40	T42	M40	M41	G40
		S50	S51	S52	S53	S54	T50	T52			
65	Protection 38/49T module 1 alarm set point sensor 1						■	■	■	■	■
66	Protection 38/49T module 1 tripping set point sensor 1						■	■	■	■	■
67	Protection 38/49T module 1 alarm set point sensor 2						■	■	■	■	■
68	Protection 38/49T module 1 tripping set point sensor 2						■	■	■	■	■
69	Protection 38/49T module 1 alarm set point sensor 3						■	■	■	■	■
70	Protection 38/49T module 1 tripping set point sensor 3						■	■	■	■	■
71	Protection 38/49T module 1 alarm set point sensor 4						■	■	■	■	■
72	Protection 38/49T module 1 tripping set point sensor 4						■	■	■	■	■
73	Protection 38/49T module 1 alarm set point sensor 5						■	■	■	■	■
74	Protection 38/49T module 1 tripping set point sensor 5						■	■	■	■	■
75	Protection 38/49T module 1 alarm set point sensor 6						■	■	■	■	■
76	Protection 38/49T module 1 tripping set point sensor 6						■	■	■	■	■
77	Protection 38/49T module 1 alarm set point sensor 7						■	■	■	■	■
78	Protection 38/49T module 1 tripping set point sensor 7						■	■	■	■	■
79	Protection 38/49T module 1 alarm set point sensor 8						■	■	■	■	■
80	Protection 38/49T module 1 tripping set point sensor 8						■	■	■	■	■

Address word 0106: TS81 to TS96 (Bit address 1060 to 106F)

TS	Application	S40	S41	S42	S43	S44	T40	T42	M40	M41	G40
		S50	S51	S52	S53	S54	T50	T52			
81	Protection 38/49T module 2 alarm set point sensor 1						■	■	■	■	■
82	Protection 38/49T module 2 tripping set point sensor 1						■	■	■	■	■
83	Protection 38/49T module 2 alarm set point sensor 2						■	■	■	■	■
84	Protection 38/49T module 2 tripping set point sensor 2						■	■	■	■	■
85	Protection 38/49T module 2 alarm set point sensor 3						■	■	■	■	■
86	Protection 38/49T module 2 tripping set point sensor 3						■	■	■	■	■
87	Protection 38/49T module 2 alarm set point sensor 4						■	■	■	■	■
88	Protection 38/49T module 2 tripping set point sensor 4						■	■	■	■	■
89	Protection 38/49T module 2 alarm set point sensor 5						■	■	■	■	■
90	Protection 38/49T module 2 tripping set point sensor 5						■	■	■	■	■
91	Protection 38/49T module 2 alarm set point sensor 6						■	■	■	■	■
92	Protection 38/49T module 2 tripping set point sensor 6						■	■	■	■	■
93	Protection 38/49T module 2 alarm set point sensor 7						■	■	■	■	■
94	Protection 38/49T module 2 tripping set point sensor 7						■	■	■	■	■
95	Protection 38/49T module 2 alarm set point sensor 8						■	■	■	■	■
96	Protection 38/49T module 2 tripping set point sensor 8						■	■	■	■	■

5

Address word 0107: TS97 to TS112 (Bit address 1070 to 107F)

TS	Application	S40 S50	S41 S51	S42 S52	S43 S53	S44 S54	T40 T50	T42 T52	M40	M41	G40
97	Recloser in service	■	■	■	■	■					
98	Recloser in progress	■	■	■	■	■					
99	Recloser final trip	■	■	■	■	■					
100	Recloser successful reclosing	■	■	■	■	■					
101	Send blocking input 1	■	■	■	■	■	■	■	■	■	■
102	Remote setting inhibited	■	■	■	■	■	■	■	■	■	■
103	Remote control inhibited	■	■	■	■	■	■	■	■	■	■
104	Sepam not reset after fault	■	■	■	■	■	■	■	■	■	■
105	TC/ position discrepancy	■	■	■	■	■	■	■	■	■	■
106	Matching fault or Trip Circuit Supervision	■	■	■	■	■	■	■	■	■	■
107	Disturbance recording stored	■	■	■	■	■	■	■	■	■	■
108	Control fault	■	■	■	■	■	■	■	■	■	■
109	Disturbance recording inhibited	■	■	■	■	■	■	■	■	■	■
110	Thermal protection inhibited						■	■	■	■	■
111	MET148-1 module sensor fault						■	■	■	■	■
112	MET148-2 module sensor fault						■	■	■	■	■

Address word 0108: TS113 to TS128 (Bit address 1080 to 108F)

TS	Application	S40 S50	S41 S51	S42 S52	S43 S53	S44 S54	T40 T50	T42 T52	M40	M41	G40
113	Thermistor tripping	■	■	■	■	■	■	■	■	■	■
114	Thermistor alarm	■	■	■	■	■	■	■	■	■	■
115	External tripping 1	■	■	■	■	■	■	■	■	■	■
116	External tripping 2	■	■	■	■	■	■	■	■	■	■
117	External tripping 3	■	■	■	■	■	■	■	■	■	■
118	Buchholz tripping						■	■			
119	Thermostat tripping						■	■			
120	Pressure tripping						■	■			
121	Buchholz alarm						■	■			
122	Thermostat alarm						■	■			
123	Pressure alarm						■	■			
124	SF6 alarm	■	■	■	■	■	■	■	■	■	■
125	Recloser ready	■	■	■	■	■					
126	Inductive ⁽¹⁾	■	■	■	■	■	■	■	■	■	■
127	Capacitive ⁽¹⁾	■	■	■	■	■	■	■	■	■	■
128	Phase inverse rotation	■	■	■	■	■	■	■	■	■	■

⁽¹⁾ TC17 can be used to inhibit this TS.

Address word 0109: TS129 to TS144 (Bit address 1090 to 109F)

TS	Application	S40 S50	S41 S51	S42 S52	S43 S53	S44 S54	T40 T50	T42 T52	M40	M41	G40
129	Send blocking input 2			■							
130	Tripping due to protection	■	■	■	■	■	■	■	■	■	■
131	S-LAN communication monitoring enabled	■	■	■	■	■	■	■	■	■	■
132	46BC protection ⁽²⁾	■	■	■	■	■	■	■			
133	Reserved										
134	Reserved										
135	Reserved										
136	Reserved										
137	Reserved										
138	Reserved										
139	Reserved										
140	Reserved										
141	Reserved										
142	Reserved										
143	Reserved										
144	Reserved										

⁽²⁾ Only available on S5X and T5X applications.

Use of remote control orders

Remote control orders are pre-assigned to protection, control and metering functions.

Remote control orders may be carried out in two modes:

- direct mode
 - confirmed SBO (select before operate) mode.
- It is possible to inhibit all the remote control orders via one logic input assigned to the function "inhibit remote control", with the exception of the remote control tripping order TC1 which can be activated at any time. The parameter setting of the logic input may be done in two modes:

- inhibition if the input is at 1
 - inhibition if the input is at 0 (negative input)
- The device tripping and closing and recloser enabling and disabling remote control orders are acknowledged if the "CB control" function is confirmed and if the inputs required for that logic are present on the MES114 (or MES108) optional module.

Direct remote control order

The remote control order is executed when it is written in the remote control word. The program logic resets it to zero after the remote control order is acknowledged.

Confirmed SBO remote control order

(select before operate)
In this mode, remote control orders involve two steps:

- selection by the master of the order to be sent by writing the bit in the STC word and checking of the selection by rereading the word
- execution of the order to be sent by writing the bit in the TC word.

The remote control order is executed if the bit in the STC word and the bit in the associated word are set: the program logic resets the STC bit and TC bits to zero after the remote control order is acknowledged.

Deselection of the STC bit takes place:

- if the master deselects it by writing in the STC word
- if the master selects (write bit) a bit other than the one already selected
- if the master sets a bit in the TC word which does not match the selection. In this case, no remote control order is executed.

Address word 00F0: TC1 to TC16 (Bit address 0F00 to 0F0F)

TC	Application	S40	S41	S42	S43	S44	T40	T42	M40	M41	G40
		S50	S51	S52	S53	S54	T50	T52			
1	Tripping	■	■	■	■	■	■	■	■	■	■
2	Closing	■	■	■	■	■	■	■	■	■	■
3	Switching to setting group A ⁽⁴⁾	■	■	■	■	■	■	■	■	■	■
4	Switching to setting group B ⁽⁴⁾	■	■	■	■	■	■	■	■	■	■
5	Sepam reset	■	■	■	■	■	■	■	■	■	■
6	Peak demand current zero reset ⁽²⁾⁽⁴⁾	■	■	■	■	■	■	■	■	■	■
7	Inhibit thermal protection ⁽⁴⁾						■	■	■	■	■
8	Inhibit disturbance recording triggering (OPG ⁽¹⁾)	■	■	■	■	■	■	■	■	■	■
9	Confirm disturbance recording triggering (OPG ⁽¹⁾)	■	■	■	■	■	■	■	■	■	■
10	Manual disturbance recording triggering (OPG ⁽¹⁾)	■	■	■	■	■	■	■	■	■	■
11	Enable recloser ⁽⁴⁾	■	■	■	■	■					
12	Disable recloser ⁽⁴⁾	■	■	■	■	■					
13	Confirm thermal protection ⁽⁴⁾						■	■	■	■	■
14	Reset undercurrent protection								■	■	
15	S-LAN communication monitoring activation ⁽³⁾⁽⁴⁾	■	■	■	■	■	■	■	■	■	■
16	S-LAN communication monitoring inhibition ⁽⁴⁾	■	■	■	■	■	■	■	■	■	■

⁽¹⁾ OPG : French acronym for disturbance recording.
⁽²⁾ Zero resetting of all the peak demands except the peak demand of the negative and positive sequence current ratio.
⁽³⁾ TC15 Remote control order follows the same TC1 inhibition mode.
⁽⁴⁾ The maximum number of remote controls is limited to 1,000,000 over the life of the product.

Address word 00F2: TC17 to TC32 (Bit address 0F20 to 0F2F)

TC	Application	S40	S41	S42	S43	S44	T40	T42	M40	M41	G40
		S50	S51	S52	S53	S54	T50	T52			
17	Inhibit TS126 (Inductive) and TS127 (Capacitive)	■	■	■	■	■	■	■	■	■	■
18	Confirm TS126 (Inductive) and TS127 (Capacitive)	■	■	■	■	■	■	■	■	■	■
19-32	Reserved										

Remote control of the analog output

The analog output of the MSA141 module may be set up for remote control via the Modbus communication link (word address 010F). The usable range of the numerical value transmitted is defined by the "min. value" and "max. value" settings of the analog output.

This function is not affected by remote control inhibition conditions.

5

Presentation

The communication system time-tags the data processed by Sepam. The time-tagging function assigns a date and precise time to status changes so that they can be accurately classified over time. Time-tagged data are events that can be processed in the control room by the remote monitoring and control system using the communication protocol for the data logging and chronological display functions.

Sepam time-tags the following data:

- logic inputs
- remote indications
- information pertaining to Sepam equipment (see Sepam check-word).

Time-tagging is carried out systematically.

The remote monitoring and control system provides a chronological display of the time-tagged data.

Time-tagging

Sepam time-tagging of events uses absolute time (see section on date and time). When an event is detected, it is tagged with the absolute time given by Sepam's internal clock.

All the Sepam internal clocks must be synchronized so as to avoid drifts and all be the same, thereby allowing inter-Sepam chronological sorting.

Sepam has two mechanisms for managing its internal clock:

■ time-setting:

to initialize or modify the absolute time. A special Modbus message, called "time message", is used to time-set each Sepam

■ synchronization:

to avoid Sepam internal clock drifts and ensure inter-Sepam synchronization.

Synchronization may be carried out according to two principles:

■ internal synchronization:

via the communication network without any additional wiring

■ external synchronization:

via a logic input with additional wiring.

At the time of commissioning, the user sets the synchronization mode parameter.

Initialization of the time-tagging function

Each time the communication system is initialized (energizing of Sepam), the events are generated in the following order:

- appearance of "data loss"
- appearance of "incorrect time"
- appearance of "not synchronous"
- disappearance of "data loss".

The function is initialized with the current values of the remote indication and logic input status without creating any events related to those data. After the initialization phase, event detection is activated.

It can only be interrupted by saturation of the internal event storage queue or by the presence of a major fault in Sepam.

Date and time

Presentation

An absolute date and time are generated internally by Sepam, comprising the following information: Year: Month: Day: Hour: minute: millisecond.

The date and time format is standardized (ref.: IEC 60870-5-4).

Power failure protection

The internal clock of Sepam is saved for 24 hours. After a power outage that lasts for more than 24 hours, the time must be reset.

The period over which Sepam data and time settings are maintained in the event of a power outage depends on the ambient temperature and the age of the Sepam unit.

Typical values:

- at 25 °C
 - 24 hours for 7 years
 - 18 hours for 10 years
 - 14 hours for 15 years
- at 40 °C
 - 24 hours for 3 years
 - 16 hours for 10 years
 - 10 hours for 15 years

Resetting the date and time

The internal clock of Sepam may be time-set in three different ways:

- by the remote monitoring and control system, via the Modbus link,
- via the SFT2841 software tool, "General characteristics" screen
- via the display of Sepam units equipped with the advanced UMI.

The time tagged on events is encoded in 8 bytes as follows:

b15	b14	b13	b12	b11	b10	b09	b08	b07	b06	b05	b04	b03	b02	b01	b00	word
0	0	0	0	0	0	0	0	0	0	Y	Y	Y	Y	Y	Y	word 1
0	0	0	0	M	M	M	M	0	0	0	D	D	D	D	D	word 2
0	0	0	H	H	H	H	H	0	0	mn	mn	mn	mn	mn	mn	word 3
ms	ms	ms	ms	ms	ms	ms	ms	ms	ms	ms	ms	ms	ms	ms	ms	word 4

Y - 1 byte for years: varies from 0 to 99 years.

The remote monitoring and control system must ensure that the year 00 is greater than 99.

M - 1 byte for months: varies from 1 to 12.

D - 1 byte for days: varies from 1 to 31.

H - 1 byte for hours: varies from 0 to 23.

mn - 1 byte for minutes: varies from 0 to 59.

ms - 2 bytes for milliseconds: varies from 0 to 59999.

These data are encoded in binary format. Sepam is time-set via the "write word" function (function 16) at the address 0002 with a mandatory 4-word time message.

The bits set to "0" in the description above correspond to format fields which are not used in and not managed by Sepam.

Since these bits can be transmitted to Sepam with random values, Sepam performs the necessary disabling.

Sepam does not check the consistency or validity of the date and time received.

Synchronization clock

A synchronization clock is required to set the Sepam date and time;

Schneider Electric has tested the following equipment:

Gorgy Timing, ref. RT300, equipped with the M540 module.

Reading of events

Sepam provides the master or masters with two event tables. The master reads the event table and acknowledges by writing the exchange word. Sepam updates its event table.

The events sent by Sepam are not sorted chronologically.

Structure of event table 1:

- exchange word 0040h
- event number 1
0041h ... 0048h
- event number 2
0049h ... 0050h
- event number 3
0051h ... 0058h
- event number 4
0059h ... 0060h

Structure of event table 2:

- exchange word 0070h
- event number 1
0071h ... 0078h
- event number 2
0079h ... 0080h
- event number 3
0081h ... 0088h
- event number 4
0089h ... 0090h

The master has to read a block of 33 words starting at the address 0040h/0070h, or 1 word at the address 0040h/0070h.

Exchange word

The exchange word is used to manage a special protocol to be sure not to lose events following a communication problem. The event table is numbered for that purpose.

The exchange word includes two fields:

- most significant byte (MSB) = exchange number (8 bits): 0..255

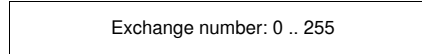
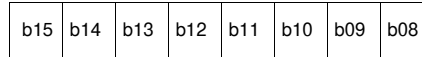

Description of the MSB of the exchange word.

The exchange number contains a numbering byte which identifies the exchanges. The exchange number is initialized to zero when Sepam is energized. When it reaches its maximum value (FFh), it automatically returns to 0. Sepam numbers the exchanges and the master acknowledges the numbering.

- least significant byte (LSB) = number of events (8 bits): 0..4.

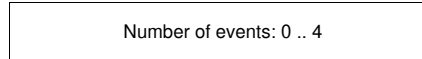
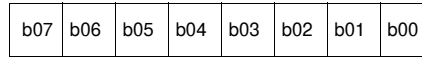

Description of the LSB of the exchange word.

Sepam indicates the number of significant events in the event table in the least significant byte of the exchange word. Each non-significant event word is initialized to zero.

Event table acknowledgment

To inform Sepam that the block read by the master has been correctly received, the master writes the number of the last exchange made in the "Exchange number" field, and resets the "Number of events" field of the exchange word to zero. After acknowledgment, the 4 events in the event table are initialized to zero and the old, acknowledged events are erased in Sepam.

Until the exchange word written by the master becomes "X,0" (with X = number of the previous exchange that the master wishes to acknowledge), the exchange word in the table remains at "X, number of previous events".

Sepam only increments the exchange number when new events are present (X+1, number of new events).

If the event table is empty, Sepam performs no processing operations when the master reads the event table or the exchange word.

The data are encoded in binary format.

Clearing an event queue

Writing a value "xxFFh" in the exchange word (any exchange number, event number = FFh) reinitializes the corresponding event queue (all stored events not yet transmitted are deleted).

This command leads the reset of the bits 10, 11, 14 and 15 of the control word without associated event generation.

Sepam in data loss (1) / no data loss (0) status

Sepam has two internal storage queues with a capacity of 64 events. If one of the queues becomes saturated, i.e. 63 events already present, the "data loss" event is generated by Sepam in the 64th position.

The detection of events stops and the most recent events are lost.

Description of event encoding

An event is encoded in 8 words with the following structure:

Most significant byte	Least significant byte	
Word 1: type of event		
08	00	For remote indications, internal data logic inputs
Word 2: event address		
		See bit addresses 1000 to 10BF
Word 3: reserved		
00	00	
Word 4: falling edge: disappearance or rising edge: appearance		
00	00	Falling edge
00	01	Rising edge
Word 5: year		
00	0 to 99 (year)	
Word 6: month-day		
1 to 12 (month)	1 to 31 (day)	
Word 7: hours-minutes		
0 to 23 (hours)	0 to 59 (minutes)	
Word 8: milliseconds		
0 to 59999		

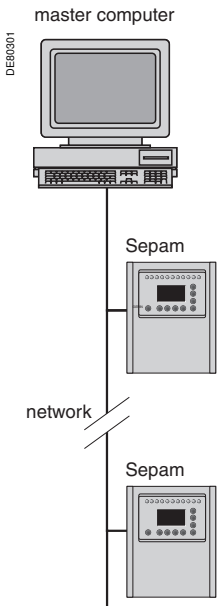

Architecture for "internal synchronization" via the communication network.

Synchronization

Sepam accommodates two synchronization modes:

- "internal via the network" synchronization mode by the broadcasting of a "time message" frame via the communication network. Slave number 0 is used for broadcasting
 - "external" synchronization mode via a logic input.
- The synchronization mode is selected at the time of commissioning via SFT2841.

Internal synchronization via the network mode

The "time message" frame is used for both time-setting and synchronization of Sepam. In this case, it must be sent regularly at brief intervals (between 10 and 60 seconds) in order for synchronous time to be obtained.

Sepam's internal clock is reset each time a new time frame is received, and synchronization is maintained if the difference in synchronism is less than 100 milliseconds.

With internal synchronization via the network, accuracy is linked to the master and its mastery of time frame transmission in the communication network.

Sepam is synchronized without delay at the end of the receipt of the frame.

Time changes are made by sending a frame to Sepam with the new date and time. Sepam then switches into a transitional non-synchronous status.

When Sepam is in synchronous status, if no "time message" is received for 200 seconds, the appearance of the "not synchronous" event is triggered.

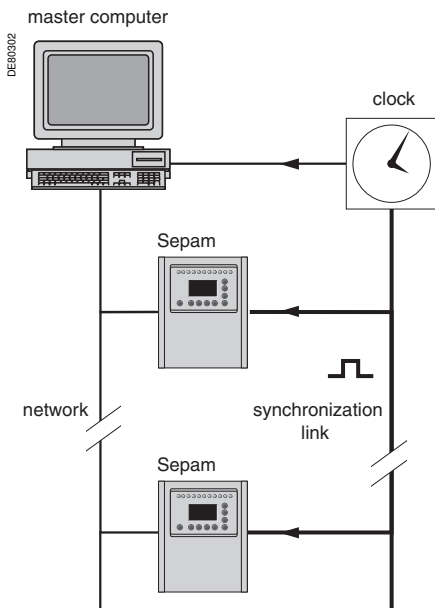

Architecture for "external synchronization" via a logic input.

Synchronization (cont'd)

External synchronization via a logic input mode

Sepam can be synchronized externally by means of a logic input (I21) (the MES114 module is required).

The synchronization pulse is determined by the rising edge of the logic input. Sepam can adapt to all synchronization pulse periods from 10 to 60 s, by 10 s steps. The shorter the synchronization period, the more accurate time-tagging of status changes is.

The first time frame is used to initialize Sepam with the absolute date and time (the following frames are used for the detection of any time changes).

The synchronization pulse is used to reset Sepam's internal clock. In the initialization phase, when Sepam is in "non-synchronous" mode, resetting is allowed, within an amplitude of ± 4 seconds.

In the initialization phase, the resetting process (switching of Sepam into "synchronous" mode) is based on a measurement of the difference between Sepam's current time and the nearest ten second period. This measurement is taken at the time of the receipt of the synchronization pulse following the initialization time frame. Resetting is allowed if the difference is less than or equal to 4 seconds, in which case Sepam switches to "synchronous" mode.

As of that time (after the switching to "synchronous" mode), the resetting process is based on the measurement of a difference (between Sepam's current time and the nearest ten second period at the time of the receipt of a synchronization pulse), which is adapted to match the synchronization pulse period.

The synchronization pulse period is determined automatically by Sepam when it is energized, based on the first two pulses received: the synchronization pulse must therefore be operational before Sepam is energized.

The synchronization function only operates after Sepam has been time-set, i.e. after the disappearance of the "incorrect time" event.

Any time changes greater than ± 4 seconds in amplitude are made by sending a new time frame. The switch from summer time to winter time (and vice versa) is made in this way as well.

There is a temporary loss of synchronism when the time is changed.

The external synchronization mode requires additional equipment, a "synchronization clock" to generate a precise periodic synchronization time pulse. If Sepam is in "correct time and synchronous" status, and if the difference in synchronism between the nearest ten second period and the receipt of the synchronization pulse is greater than the synchronism error for 2 consecutive synchronization pulses, it switches into non-synchronous status and generates the appearance of a "not synchronous" event.

Likewise, if Sepam is in "correct time and synchronous" status, the failure to receive a synchronization pulse for 200 seconds generates the appearance of a "not synchronous" event.

Reading of remote settings (remote reading)

Settings accessible for remote reading

Reading of the settings of all the protection functions may be accessed remotely in 2 independent zones to enable operation with 2 masters.

Exchange principle

Remote reading of settings (remote reading) takes place in two steps:

- first of all, the master indicates the code of the function for which it wishes to know the settings by means of a "request frame". The request is acknowledged, in the Modbus sense of the term, to free the network

- the master then reads a reply zone to find the required information by means of a "reply frame".

Each function has its own particular reply zone contents. The time needed between the request and the reply is linked to Sepam's low-priority cycle time and may vary from a few tens to several hundreds of milliseconds.

- setting zone 1
 - read: 1E00h-1E7Ch
 - read request: 1E80h
 - remote setting: 1F00h-1F7Ch
- setting zone 2
 - read: 2000h -207Ch
 - read request: 2080h
 - remote setting: 2100h -217Ch

Request frame

The request is made by the master using a "write word" operation (function 6 or 16) at the address 1E80h or 2080h of a 1-word frame consisting of the following:

1E80h/2080h

B15	B14	B13	B12	B11	B10	B09	B08	B07	B06	B05	B04	B03	B02	B01	B00
Function code								Unit number							

The content of the address 1E80h/2080h may be read using a Modbus "read word" operation (function 3).

The function code field may have the following values:

- 01h to 99h (BCD encoding) for protection functions.
- The unit number field is used as follows:
 - for protection functions, it indicates the unit involved, varying from 1 to N, N being the maximum number of relays available in the Sepam
 - when only one unit of a protection function is available, this number field is not controlled.

Exception replies

In addition to the usual cases, Sepam can send Modbus type 07 exception replies (not acknowledged) if another remote reading request is being processed.

Reply frame

The reply, sent back by Sepam, fits into a zone with a maximum length of 25 words at the address 1E00h or 2000h, which comprises the following:

1E00h-1E7Ch/2000h-207Ch

B15	B14	B13	B12	B11	B10	B09	B08	B07	B06	B05	B04	B03	B02	B01	B00
Function code								Unit number							
Settings															
.....															
(special field for each function)															
.....															

This zone is read by a Modbus "read word" operation (function 3) at the address 2000h.

The length of the exchange may concern:

- first word only (validity test)
- maximum size of the zone (125 mots)
- usable size of the zone (determined by the function being addressed).

However, reading must always begin at the first word in the zone (any other address triggers an exception reply "incorrect address").

The first word in the zone (function code and unit number) may have the following values:

- **xyyy**: with
 - function code xx different from 00 and FFh
 - unit number yy different from FFh.

The settings are available and confirmed. They word is a copy of the "request frame". The zone contents remain valid until the next request is made.

- **FFFFh**: the "request frame" has been processed, but the results in the "reply zone" are not yet available. It is necessary to repeat "reply frame" reading. The other words are not significant.

- **xxFFh**: with the function code xx different from 00 and FFh. The read request for the settings of the designated function is not valid. The function is not included in the particular Sepam, or remote reading of it is not authorized: refer to the list of functions which accommodate remote reading of settings.



NOTICE

RISK OF UNINTENDED OPERATION

- The device must only be configured and set by qualified personnel, using the results of the installation protection system study.
- During commissioning of the installation and following any modification, check that the Sepam configuration and protection function settings are consistent with the results of this study.

Failure to follow these instructions can result in equipment damage.

Remote setting

Data that can be remotely set

Writing of the settings of all the protection functions may be accessed remotely.

Exchange principle

Remote setting is allowed for Sepam units.

Remote setting is carried out for a given function unit by unit.

It takes place in two steps:

- first of all, the master indicates the function code and unit number, followed by the values of all the settings in the "write request frame". The request is acknowledged to free the network
 - the master then reads a reply zone designed for checking that the settings have been processed. Each function has its own particular reply zone contents. They are the same as those of the remote reading function reply frame.
- To use remote setting, it is necessary to make all the settings for the function concerned, even if some of them have not changed.

Request frame

The request is made by the master using a "write n words" operation (function 16) at the address 1F00h or 2100h. The zone to be written contains a maximum of 123 words.

It contains the values of all the settings and consists of the following:

1F00h/2100h

B15	B14	B13	B12	B11	B10	B09	B08	B07	B06	B05	B04	B03	B02	B01	B00
Function code								Unit number							
Settings															
.....															
(special field for each function)															
.....															

The content of the address 2100h may be read using a "read n words" operation (function 3).

- the function code field may have the following values: 01h to 99h (BCD encoding) for the list of protection functions F01 to F99
- the unit number field is used as follows: for protection functions, it indicates the unit involved, varying from 1 to N, N being the maximum number of units available in the Sepam. It may never be equal to 0.

Exception reply

In addition to the usual cases, le Sepam can send type 07 exception replies (not acknowledged) if:

- another remote reading or setting request is being processed
- the remote setting function is inhibited.

Reply frame

The reply sent back by Sepam is the same as the remote reading reply frame. It fits into a zone with a maximum length of 125 words at the address 1E00h or 2000h, and is composed of the effective settings of the function following a semantic check:

1E00h-1E7Ch/2000h-207Ch

B15	B14	B13	B12	B11	B10	B09	B08	B07	B06	B05	B04	B03	B02	B01	B00
Function code								Unit number							
Settings															
.....															
(special field for each function)															
.....															

This zone is read by a "read n words" operation (function 3) at the address 1E00h or 2000h.

The length of the exchange may concern:

- first word only (validity test)
 - maximum size of the zone (125 words)
 - usable size of the zone (determined by the function being addressed).
- However, reading must always begin at the first word in the zone (any other address triggers an exception reply "incorrect address").

The first word in the zone (function code and unit number) has the same values as those described for the remote reading reply frame.

- **xyyy**: with:
 - function code xx different from 00 and FFh
 - unit number yy different from FFh.

The settings are available and confirmed. The word is a copy of the "request frame". The zone contents remain valid until the next request is made.

- **0000h**: no "request frame" has yet been formulated. This is especially the case when Sepam is energized.

The other words are not significant.

- **FFFFh**: the "request frame" has been processed, but the results in the "reply zone" are not yet available. It is necessary to repeat "reply frame" reading. The other words are not significant.

- **xxFFh**: with the function code xx different from 00 and FFh. The read request for the settings of the designated function is not valid. The function is not included in the particular Sepam, or access to settings is impossible, in both read and write modes.

5

Description of settings

Data format

All the settings are transmitted in signed 32-bit integer format (encoding, as a complement of 2).

Particular setting value:

7FFF FFFFh means that the setting is out of the validity range.

① The Enabled or Disabled setting is encoded as follows:

0 = Disabled, 1 = Enabled

② The tripping curve setting is encoded as follows:

0 = definite

1 = inverse

2 = long time inverse

3 = very inverse

4 = extremely inverse

5 = ultra inverse

6 = RI

7 = IEC SIT/A

8 = IEC LTI/B

9 = IEC VIT/B

10 = IEC EIT/C

11 = IEEE Mod. inverse

12 = IEEE Very inverse

13 = IEEE Extr. inverse

14 = IAC inverse

15 = IAC very inverse

16 = IAC extr. inverse

③ The timer hold delay curve setting is encoded as follows:

0 = definite time

1 = IDMT

④ The H2 restraint variable is encoded as follows:

0 = H2 restraint

1 = no H2 restraint

⑤ The tripping curve setting is:

0 = definite time

1 = IDMT

⑥ Setting of latching and CB control

0 = No

1 = Yes

⑦ Tripping curve for negative sequence undercurrent:

0 = definite

7 = IEC SIT/A

8 = IEC LTI/B

9 = IEC VIT/B

10 = IEC EIT/C

11 = IEEE Mod. inverse

12 = IEEE Very inverse

13 = IEEE Extr. inverse

17 = Schneider specific

⑧ The activation of each of the cycles is encoded as follows:

Correspondence between bit position / protection according to the table below:

Bit	Activation by
0	Instantaneous phase overcurrent, unit 1
1	Time-delayed phase overcurrent, unit 1
2	Instantaneous phase overcurrent, unit 2
3	Time-delayed phase overcurrent, unit 2
4	Instantaneous phase overcurrent, unit 3
5	Time-delayed phase overcurrent, unit 3
6	Instantaneous phase overcurrent, unit 4
7	Time-delayed phase overcurrent, unit 4
8	Instantaneous earth fault, unit 1
9	Time-delayed earth fault, unit 1
10	Instantaneous earth fault, unit 2
11	Time-delayed earth fault, unit 2
12	Instantaneous earth fault, unit 3
13	Time-delayed earth fault, unit 3
14	Instantaneous earth fault, unit 4
15	Time-delayed earth fault, unit 4
16	Instantaneous directional earth fault, unit 1
17	Time-delayed directional earth fault, unit 1
18	Instantaneous directional earth fault, unit 2
19	Time-delayed directional earth fault, unit 2
20	Instantaneous directional phase overcurrent, unit 1
21	Time-delayed directional phase overcurrent, unit 1
22	Instantaneous directional phase overcurrent, unit 2
23	Time-delayed directional phase overcurrent, unit 2
24	V_TRIPCB (logic equation)

The bit status is encoded as follows:

0 = No activation by the protection function

1 = Activation by the protection function.

⑨ The time delay unit of the CLPU functions is coded the following way:

0 = millisecond

1 = second

2 = minute

General settings

Function number: 3002

Setting	Data	Format/Unit
1	Rated frequency	0 = 50 Hz, 1 = 60 Hz
2	Remote setting enabled	1 = disabled
3	Working language	0 = English, 1 = other
4	Active group of settings	0 = Group A 1 = Group B 3 = Choice by I13 4 = Choice by remote control
5	Setting mode	0 = TMS, 1 = I/Is
6	Phase CT rating	0 = 5 A, 1 = 1 A, 2 = LPCT
7	Number of phase CTs	0 = 3 CTs, 1 = 2 CTs
8	Rated current In	A
9	Basic current Ib	A
10	Residual current determination mode	0 = None 1 = 2 A CSH 2 = 20 A CSH 3 = 1 A CT 4 = 5 A CT 5 = ACE990 Range 1 6 = ACE990 Range 2 7 = 5 A CSH 8 = Sensitive 1 A CT 9 = Sensitive 5 A CT
11	Rated residual current (In0)	0.1 A
12	Integration period	0 = 5 mn, 1 = 10 mn 2 = 15 mn, 3 = 30 mn 4 = 60 mn
13	<i>Reserved</i>	
14	Rated primary voltage Unp	V
15	Rated secondary voltage Uns	0 = 100 V, 1 = 110 V 2 = 115 V, 3 = 120 V 4 = 200 V, 5 = 230 V 6 = Numerical value, see setting 21
16	VT wiring	0 = 3 V, 1 = 2 U, 2 = 1 U
17	Residual voltage mode	0 = None 1 = $\Sigma 3 V$ 2 = external VT – $Uns/\sqrt{3}$ 3 = external VT – $Uns/3$
18	Type of cubicle	0 = incomer 1 = feeder
19	Increment active power	0.1 kW.h
20	Increment reactive power	0.1 kvar.h
21	Rated secondary voltage Uns	V

Protection settings

They are organized according to increasing ANSI codes.

ANSI 27/27S - Undervoltage

Function number: 10xx

relay 1: xx = 01, relay 2: xx = 02

Setting	Data	Format/Unit
1	Latching	⑥
2	CB control	⑥
3	Activity	①
4	<i>Reserved</i>	-
5	<i>Reserved</i>	-
6	Voltage mode	0 = phase-to-neutral, 1 = phase-to-phase
7	Us (or Vs) set point	% Unp (or Vnp)
8	Tripping time delay	10 ms
9	<i>Reserved</i>	-
10	<i>Reserved</i>	-
11	<i>Reserved</i>	-
12	<i>Reserved</i>	-

ANSI 27D - Positive sequence undervoltage

Function number: 08xx

relay 1: xx = 01, relay 2: xx = 02

Setting	Data	Format/Unit
1	Latching	⑥
2	CB control	⑥
3	Activity	①
4	<i>Reserved</i>	-
5	<i>Reserved</i>	-
6	Vsd set point	% Unp
7	Tripping time delay	10 ms
8	<i>Reserved</i>	-
9	<i>Reserved</i>	-
10	<i>Reserved</i>	-
11	<i>Reserved</i>	-

ANSI 27R - Remanent undervoltage

Function number: 0901

Setting	Data	Format/Unit
1	Latching	⑥
2	<i>Reserved</i>	-
3	Activity	①
4	<i>Reserved</i>	-
5	<i>Reserved</i>	-
6	Us set point	% Unp
7	Tripping time delay	10 ms
8	<i>Reserved</i>	-
9	<i>Reserved</i>	-
10	<i>Reserved</i>	-
11	<i>Reserved</i>	-

ANSI 32P - Active overpower

Function number: 2301

Setting	Data	Format/Unit
1	Latching	⑥
2	CB control	⑥
3	Activity	①
4	Type	0 = reverse power 1 = overpower
5	<i>Reserved</i>	-
6	<i>Reserved</i>	-
7	Ps set point	100 W
8	Tripping time delay	10 ms
9	<i>Reserved</i>	-
10	<i>Reserved</i>	-
11	<i>Reserved</i>	-
12	<i>Reserved</i>	-

ANSI 32Q - Reactive overpower

Function number: 2401

Setting	Data	Format/Unit
1	Latching	⑥
2	CB control	⑥
3	Activity	①
4	Type	0 = reverse power 1 = overpower
5	<i>Reserved</i>	-
6	<i>Reserved</i>	-
7	Qs set point	100 var
8	Tripping time delay	10 ms
9	<i>Reserved</i>	-
10	<i>Reserved</i>	-
11	<i>Reserved</i>	-
12	<i>Reserved</i>	-

ANSI 37 - Phase undercurrent

Function number: 0501

Setting	Data	Format/Unit
1	Latching	⑥
2	CB control	⑥
3	Activity	①
4	<i>Reserved</i>	-
5	<i>Reserved</i>	-
6	Is set point	% Ib
7	Tripping time delay	10 ms
8	<i>Reserved</i>	-
9	<i>Reserved</i>	-
10	<i>Reserved</i>	-
11	<i>Reserved</i>	-

ANSI 38/49T - Temperature monitoring

Function number: 15xx

relay 1: xx = 01 to relay 16: xx = 10h

Setting	Data	Format/Unit
1	Latching	⑥
2	CB control	⑥
3	Activity	①
4	<i>Reserved</i>	-
5	<i>Reserved</i>	-
6	Alarm set point	°C
7	Trip set point	°C
8	<i>Reserved</i>	-
9	<i>Reserved</i>	-
10	<i>Reserved</i>	-
11	<i>Reserved</i>	-

ANSI 46 - Negative sequence / unbalance

Function number: 03xx

relay 1: xx = 01, relay 2: xx = 02

Setting	Data	Format/Unit
1	Latching	⑥
2	CB control	⑥
3	Activity	①
4	<i>Reserved</i>	-
5	<i>Reserved</i>	-
6	Tripping curve	⑦
7	Is set point	% Ib
8	Tripping time delay	10 ms
9	<i>Reserved</i>	-
10	<i>Reserved</i>	-
11	<i>Reserved</i>	-
12	<i>Reserved</i>	-

ANSI 46BC - Broken Conductor

Function number: 2801

Setting	Data	Format/Unit
1	Latching	⑥
2	CB control	⑥
3	Activity	①
4	<i>Reserved</i>	-
5	<i>Reserved</i>	-
6	Set point	%
7	Tripping time delay	10 ms

ANSI 47 - Negative sequence overvoltage

Function number: 1901

Setting	Data	Format/Unit
1	Latching	⑥
2	CB control	⑥
3	Activity	①
4	<i>Reserved</i>	-
5	<i>Reserved</i>	-
6	Vsi set point	% Unp
7	Tripping time delay	10 ms
8	<i>Reserved</i>	-
9	<i>Reserved</i>	-
10	<i>Reserved</i>	-
11	<i>Reserved</i>	-

ANSI 48/51LR/14 - Locked rotor, excessive starting time

Function number: 0601

Setting	Data	Format/Unit
1	Latching	⑥
2	CB control	⑥
3	Activity	①
4	<i>Reserved</i>	-
5	<i>Reserved</i>	-
6	Is set point	% Ib
7	Excessive starting time delay	10 ms
8	Locked rotor time delay	10 ms
9	Locked rotor on start time delay	10 ms
10	<i>Reserved</i>	-
11	<i>Reserved</i>	-
12	<i>Reserved</i>	-
13	<i>Reserved</i>	-

ANSI 49RMS - Thermal overload

Function number: 0401

Setting	Data	Format/Unit
1	Latching	⑥
2	CB control	⑥
3	Activity	①
4	Negative sequence factor K	0: without 1: low (2.25) 2: average (4.5) 3: high (9)
5	Current threshold Is (switching from rate 1/rate 2) % Ib	
6	Accounting for ambient temperature	0: no 1: yes
7	Maximum equipment temperature	°C
8	Additional settings taken into account (rate 2)	0: no 1: yes
9	Learnt cooling time constant (T2 learnt) taken into account	0: no 1: yes
10	<i>Reserved</i>	
11	<i>Reserved</i>	
12	Rate 1 - heatrise alarm set point	%
13	Rate 1 - heatrise tripping set point	%
14	Rate 1 - heating time constant	mn
15	Rate 1 - cooling time constant	mn
16	Rate 1 - initial heatrise	%
17	<i>Reserved</i>	
18	<i>Reserved</i>	
19	<i>Reserved</i>	
20	<i>Reserved</i>	
21	<i>Reserved</i>	
22	Rate 2 - heatrise alarm set point	%
23	Rate 2 - heatrise tripping set point	%
24	Rate 2 - heating time constant	mn
25	Rate 2 - cooling time constant	mn
26	Rate 2 - initial heatrise	%
27	Rate 2 - base current for rate 2	0.1 A
28	<i>Reserved</i>	
29	<i>Reserved</i>	
30	<i>Reserved</i>	
31	<i>Reserved</i>	

ANSI 50/51 - Phase overcurrent

Function number: 01xx

relay 1: xx = 01 to relay 4: xx = 04

Setting	Data	Format/Unit
1	Latching	⑥
2	CB control	⑥
3	Activity	①
4	Confirmation	0 = none, 1 = neg. seq. overvoltage, 2 = undervoltage
5	H2 restraint set point ⁽¹⁾	%
6	<i>Reserved</i>	-
7	Group A – tripping curve	②
8	Group A – Is set point	0.1 A
9	Group A – tripping time delay	10 ms
10	Group A – timer hold curve	③
11	Group A – timer hold delay	10 ms
12	Group A – H2 restraint	①
13	Group A – Iscmin	0.1 A
14	<i>Reserved</i>	-
15	<i>Reserved</i>	-
16	Group B – tripping curve	②
17	Group B – Is set point	0.1 A
18	Group B – tripping time delay	10 ms
19	Group B – timer hold curve	③
20	Group B – timer hold delay	10 ms
21	Group B – H2 restraint	①
22	Group B – Iscmin	0.1 A
23	<i>Reserved</i>	-
24	<i>Reserved</i>	-

*(1) Set point utilized by all the groups.***ANSI 50BF - Breaker failure**

Function number: 2001

Setting	Data	Format/Unit
1	Latching	⑥
2	<i>Reserved</i>	-
3	Activity	①
4	<i>Reserved</i>	-
5	<i>Reserved</i>	-
6	Use close position of circuit breaker	⑥
7	Is set point	0.1 A
8	Tripping time delay	10 ms
9	<i>Reserved</i>	-
10	<i>Reserved</i>	-
11	<i>Reserved</i>	-
12	<i>Reserved</i>	-

ANSI 50N/51N - Earth fault

Function number: 02xx

relay 1: xx = 01 to relay 4: xx = 04

Setting	Data	Format/Unit
1	Latching	⑥
2	CB control	⑥
3	Activity	①
4	Type of I0	0 calculated, 1 measured
5	<i>Reserved</i>	-
6	<i>Reserved</i>	-
7	Group A – tripping curve	②
8	Group A – Is0 set point	0.1 A
9	Group A – tripping time delay	10 ms
10	Group A – timer hold curve	③
11	Group A – timer hold delay	10 ms
12	Group A – H2 restraint	0 yes, 1 no
13	<i>Reserved</i>	-
14	<i>Reserved</i>	-
15	<i>Reserved</i>	-
16	<i>Reserved</i>	-
17	Group B – tripping curve	②
18	Group B – Is0 set point	0.1 A
19	Group B – tripping time delay	10 ms
20	Group B – timer hold curve	③
21	Group B – timer hold delay	10 ms
22	Group B – H2 restraint	0 yes, 1 no
23	<i>Reserved</i>	-
24	<i>Reserved</i>	-
25	<i>Reserved</i>	-
26	<i>Reserved</i>	-

ANSI 51V - Voltage-restrained phase overcurrent

Function number: 2501

Setting	Data	Format/Unit
1	Latching	⑥
2	CB control	⑥
3	Activity	①
4	<i>Reserved</i>	-
5	<i>Reserved</i>	-
6	Tripping curve	②
7	Is set point	0.1 A
8	Tripping time delay	10 ms
9	Timer hold curve	③
10	Timer hold delay	10 ms
11	<i>Reserved</i>	-
12	<i>Reserved</i>	-
13	<i>Reserved</i>	-
14	<i>Reserved</i>	-

ANSI 59 - Overvoltage

Function number: 11xx

relay 1: xx = 01, relay 2: xx = 02

Setting	Data	Format/Unit
1	Latching	⑥
2	CB control	⑥
3	Activity	①
4	<i>Reserved</i>	-
5	<i>Reserved</i>	-
6	Voltage mode	0 = phase-to-neutral 1 = phase-to-phase
7	Us (or Vs) set point	% Unp (or Vnp)
8	Tripping time delay	10 ms
9	<i>Reserved</i>	-
10	<i>Reserved</i>	-
11	<i>Reserved</i>	-
12	<i>Reserved</i>	-

ANSI 59N - Neutral voltage displacement

Function number: 12xx

relay 1: xx = 01, relay 2: xx = 02

Setting	Data	Format/Unit
1	Latching	⑥
2	CB control	⑥
3	Activity	①
4	<i>Reserved</i>	-
5	<i>Reserved</i>	-
6	Vs0 set point	% Unp
7	Tripping time delay	10 ms
8	<i>Reserved</i>	-
9	<i>Reserved</i>	-
10	<i>Reserved</i>	-
11	<i>Reserved</i>	-

ANSI 66 - Starts per hour

Function number: 0701

Setting	Data	Format/Unit
1	Latching	⑥
2	<i>Reserved</i>	-
3	Activity	①
4	<i>Reserved</i>	-
5	<i>Reserved</i>	-
6	Period of time	Hours
7	Total number of starts	1
8	Number of consecutive hot starts	1
9	Number of consecutive starts	1
10	Time delay between starts	Minutes
11	<i>Reserved</i>	-
12	<i>Reserved</i>	-
13	<i>Reserved</i>	-
14	<i>Reserved</i>	-

ANSI 67 - Directional phase overcurrent

Function number: 21xx

relay 1: xx = 01, relay 2: xx = 02

Setting	Data	Format/Unit
1	Latching	⑥
2	CB control	⑥
3	Activity	①
4	<i>Reserved</i>	-
5	<i>Reserved</i>	-
6	Group A – direction	0 line, 1 busbar
7	Group A – characteristic angle	0 = 30° angle 1 = 45° angle 2 = 60° angle
8	Group A – tripping logic	0 = one out of three 1 = two out of three
9	Group A – tripping curve	②
10	Group A – Is set point	0.1 A
11	Group A – tripping time delay	10 ms
12	Group A – timer hold curve	③
13	Group A – timer hold delay	10 ms
14	<i>Reserved</i>	-
15	<i>Reserved</i>	-
16	<i>Reserved</i>	-
17	<i>Reserved</i>	-
18	Group B – direction	0 line, 1 busbar
19	Group B – characteristic angle	0 = 30° angle 1 = 45° angle 2 = 60° angle
20	Group B – tripping logic	0: 1 on 3, 1: 2 on 3
21	Group B – tripping curve	②
22	Group B – Is set point	0.1 A
23	Group B – tripping time delay	10 ms
24	Group B – timer hold curve	③
25	Group B – timer hold delay	10 ms
26	<i>Reserved</i>	-
27	<i>Reserved</i>	-
28	<i>Reserved</i>	-
29	<i>Reserved</i>	-

ANSI 67N/67NC - Directional earth fault

Function number: 22xx

relay 1: xx = 01, relay 2: xx = 02

Setting	Data	Format/Unit
1	Latching	⑥
2	CB control	⑥
3	Activity	①
4	Type	0 = projection 1 = directionalized
5	Type of I0 (Sum or Core balance CT)	0 calculated, 1 measured
6	<i>Reserved</i>	-
7	<i>Reserved</i>	-
8	Group A – direction	0 line, 1 busbar
9	Group A – types 1 and 2: characteristic angle	0 = -45° angle 1 = 0° angle 2 = 15° angle 3 = 30° angle 4 = 45° angle 5 = 60° angle 6 = 90° angle
	Group A – type 3: limit 1	0 to 359°
10	Group A – type 1: sector	2 = 76° sector 3 = 83° sector 4 = 86° sector
	Group A – type 3: limit 2	0 to 359°
11	Group A – tripping curve	②
12	Group A – types 1 and 2: Is0 set point	0.1 A
	Group A – type 3: Is0 set point	0.01 A
13	Group A – tripping time delay	10 ms
14	Group A – types 1 and 2: Vs0	% Unp
	Group A – type 3: Vs0	0.1 % Unp
15	Group A – timer hold curve	③
16	Group A – timer hold delay	10 ms
17	Group A – memory time	10 ms
18	Group A – memory voltage	% Unp
19	<i>Reserved</i>	-
20	<i>Reserved</i>	-
21	<i>Reserved</i>	-
22	<i>Reserved</i>	-
23	Group B – direction	0 line, 1 busbar
24	Group B – types 1 and 2: characteristic angle	0 = -45° angle 1 = 0° angle 2 = 15° angle 3 = 30° angle 4 = 45° angle 5 = 60° angle 6 = 90° angle
	Group B – type 3: limit 1	0 to 359°
25	Group B – type 1: sector	2 = 76° sector 3 = 83° sector 4 = 86° sector
	Group B – type 3: limit 2	0 to 359°
26	Group B – tripping curve	②
27	Group B – types 1 and 2: Is0 set point	0.1 A
	Group B – type 3: Is0 set point	0.01 A
28	Group B – tripping time delay	10 ms
29	Group B – types 1 and 2: Vs0	% Unp
	Group B – type 3: Vs0	0.1 % Unp
30	Group B – timer hold curve	③
31	Group B – timer hold delay	10 ms
32	Group B – memory time	10 ms
33	Group B – memory voltage	% Unp
34	<i>Reserved</i>	-
35	<i>Reserved</i>	-
36	<i>Reserved</i>	-
37	<i>Reserved</i>	-

ANSI 79 - Recloser

Function number: 1701

Setting	Data	Format/Unit
1	Activity	①
2	Number of cycles	1 to 4
3	Reclaim time	10 ms
4	Safety time until ready	10 ms
5	Dead time extension	⑥
6	Maximum waiting time	10 ms
7	<i>Reserved</i>	-
8	<i>Reserved</i>	-
9	Cycle 1 activation mode	⑧
10	Cycle 1 dead time	10 ms
11	<i>Reserved</i>	-
12	<i>Reserved</i>	-
13	Cycle 2, 3, 4 activation mode	⑧
14	Cycle 2 dead time	10 ms
15	Cycle 3 dead time	10 ms
16	Cycle 4 dead time	10 ms
17	<i>Reserved</i>	-
18	<i>Reserved</i>	-

ANSI 81H - Overfrequency

Function number: 13xx

relay 1: xx = 01, relay 2: xx = 02

Setting	Data	Format/Unit
1	Latching	⑥
2	CB control	⑥
3	Activity	①
4	<i>Reserved</i>	-
5	<i>Reserved</i>	-
6	Fs set point	0.1 Hz
7	Tripping time delay	10 ms
8	<i>Reserved</i>	-
9	Vs set point	% Unp
10	<i>Reserved</i>	-
11	<i>Reserved</i>	-
12	<i>Reserved</i>	-
13	<i>Reserved</i>	-

ANSI 81L - Underfrequency

Function number: 14xx

relay 1: xx = 01 to relay 4: xx = 04

Setting	Data	Format/Unit
1	Latching	⑥
2	CB control	⑥
3	Activity	①
4	<i>Reserved</i>	-
5	<i>Reserved</i>	-
6	Fs set point	0.1 Hz
7	Tripping time delay	10 ms
8	Restraint	0 none 1 on frequency variation
9	Vs set point	% Unp
10	Inhibited threshold	on frequency variation
11	<i>Reserved</i>	-
12	<i>Reserved</i>	-
13	<i>Reserved</i>	-
14	<i>Reserved</i>	-

CLPU 50/51 and CLPU 50N/51N protection settings

Function number: 2A01

Setting	Data	Format/Unit
1	Reserved	-
2	Reserved	-
3	Reserved	-
4	Time before activation Tcold	10 ms
5	Pick-up threshold CLPUs	% In
6	Reserved	-
7	CLPU 50/51 global action setting	0 = blocking 1 = multiplication
8	Activation of ANSI 50/51 protection unit x: OFF or ON	(1) (2)
9	Unit 1 / Group A 50/51: unit of activation time delay T	(9)
10	Unit 1 / Group A 50/51: activation time delay T	(1)
11	Unit 1 / Group A 50/51: multiplying factor M	% Is
12	Unit 2 / Group A 50/51: unit of activation time delay T	(9)
13	Unit 2 / Group A 50/51: activation time delay T	(1)
14	Unit 2 / Group A 50/51: multiplying factor M	% Is
15	Unit 3 / Group A 50/51: unit of activation time delay T	(9)
16	Unit 3 / Group A 50/51: activation time delay T	(1)
17	Unit 3 / Group A 50/51: multiplying factor M	% Is
18	Unit 4 / Group A 50/51: unit of activation time delay T	(9)
19	Unit 4 / Group A 50/51: activation time delay T	(1)
20	Unit 4 / Group A 50/51: multiplying factor M	% Is
21	Unit 1 / Group B 50/51: unit of activation time delay T	(9)
22	Unit 1 / Group B 50/51: activation time delay T	(1)
23	Unit 1 / Group B 50/51: multiplying factor M	% Is
24	Unit 2 / Group B 50/51: unit of activation time delay T	(9)
25	Unit 2 / Group B 50/51: activation time delay T	(1)
26	Unit 2 / Group B 50/51: multiplying factor M	% Is
27	Unit 3 / Group B 50/51: unit of activation time delay T	(9)
28	Unit 3 / Group B 50/51: activation time delay T	(1)
29	Unit 3 / Group B 50/51: multiplying factor M	% Is
30	Unit 4 / Group B 50/51: unit of activation time delay T	(9)
31	Unit 4 / Group B 50/51: activation time delay T	(1)
32	Unit 4 / Group B 50/51: multiplying factor M	% Is
33	CLPU 50N/51N global action setting	0 = blocking 1 = multiplication
34	Activation of ANSI 50N/51N protection unit x: OFF or ON	(1) (2)
35	Unit 1 / Group A 50N/51N: unit of activation time delay T0	(9)
36	Unit 1 / Group A 50N/51N: activation time delay T0	(1)
37	Unit 1 / Group A 50N/51N: multiplying factor M0	% Is0
38	Unit 2 / Group A 50N/51N: unit of activation time delay T0	(9)
39	Unit 2 / Group A 50N/51N: activation time delay T0	(1)
40	Unit 2 / Group A 50N/51N: multiplying factor M0	% Is0
41	Unit 3 / Group A 50N/51N: unit of activation time delay T0	(9)
42	Unit 3 / Group A 50N/51N: activation time delay T0	(1)
43	Unit 3 / Group A 50N/51N: multiplying factor M0	% Is0
44	Unit 4 / Group A 50N/51N: unit of activation time delay T0	(9)
45	Unit 4 / Group A 50N/51N: activation time delay T0	(1)
46	Unit 4 / Group A 50N/51N: multiplying factor M0	% Is0
47	Unit 1 / Group B 50N/51N: unit of activation time delay T0	(9)
48	Unit 1 / Group B 50N/51N: activation time delay T0	(1)
49	Unit 1 / Group B 50N/51N: multiplying factor M0	% Is0
50	Unit 2 / Group B 50N/51N: unit of activation time delay T0	(9)
51	Unit 2 / Group B 50N/51N: activation time delay T0	(1)
52	Unit 2 / Group B 50N/51N: multiplying factor M0	% Is0
53	Unit 3 / Group B 50N/51N: unit of activation time delay T0	(9)
54	Unit 3 / Group B 50N/51N: activation time delay T0	(1)
55	Unit 3 / Group B 50N/51N: multiplying factor M0	% Is0
56	Unit 4 / Group B 50N/51N: unit of activation time delay T0	(9)
57	Unit 4 / Group B 50N/51N: activation time delay T0	(1)
58	Unit 4 / Group B 50N/51N: multiplying factor M0	% Is0

(1) numerical value, see setting of time delay unit T.

(2) bit 0 : unit 1 group A activation
bit 1 : unit 2 group A activation
bit 2 : unit 3 group A activation
bit 3 : unit 4 group A activation
bit 4 : unit 1 group B activation
bit 5 : unit 2 group B activation
bit 6 : unit 3 group B activation
bit 7 : unit 4 group B activation

Other protection settings**ANSI 21FL - Fault Locator**

Function number : 2901

Setting	Data	Format/Unit
1	Reserved	-
2	Reserved	-
3	Activity	①
4	Time delay T	Numerical value, see unit at setting 5
5	Unit of time delay T	0 = s 1 = mn
6	Location unit ⁽¹⁾	0 = km 1 = miles
7	Positive sequence resistance of lines (Rdl)	mΩ/km
8	Positive sequence reactance of lines (Xdl)	mΩ/km
9	Zero sequence resistance of lines (R0l)	mΩ/km
10	Zero sequence reactance of lines (X0l)	mΩ/km
11	Positive sequence resistance of cables (Rdc)	mΩ/km
12	Positive sequence reactance of cables (Xdc)	mΩ/km
13	Zero sequence resistance of cables (R0c)	mΩ/km
14	Zero sequence reactance of cables (X0c)	mΩ/km
15	Percentage of cable	%

(1) This parameter is only valid to display the settings 7 to 14 on the advanced UMI and SFT2841 software.

ANSI 60 - CT supervision

Function number: 2601

Setting	Data	Format/Unit
1	Reserved	-
2	Reserved	-
3	Activity	①
4	Reserved	-
5	Reserved	-
6	Behavior on 46, 51N, 32P, 32Q functions	0 none, 1 inhibition
7	Tripping time delay	10 ms
8	Reserved	-
9	Reserved	-
10	Reserved	-
11	Reserved	-

ANSI 60FL - VT supervision

Function number: 2701

Setting	Data	Format/Unit
1	Reserved	-
2	Reserved	-
3	Activity	①
4	Reserved	-
5	Reserved	-
6	Check loss of 3 V/2 U	⑥
7	Test current	⑥
8	Use Vi, li criterion	⑥
9	Behavior on 27/27S, 27D, 32P, 32Q, 47, 51V, 59, 59N functions	0 none, 1 inhibition
10	Behavior on 67 function	0 non directional, 1 inhibition
11	Behavior on 67N function	0 non directional, 1 inhibition
12	Vi set point	% Vn
13	li set point	% In
14	Time delay loss 3 V/ 2 U	10 ms
15	Time delay Vi, li	10 ms
16	Reserved	-
17	Reserved	-
18	Reserved	-
19	Reserved	-

Presentation

The disturbance recording function is used to record analog and logical signals during a time interval. Sepam can store up to 19 records.

Each record comprises two files:

- configuration file with suffix .CFG
- data file with suffix .DAT.

The data of each record may be transferred via the Modbus link.

It is possible to transfer 1 to 19 records to a remote monitoring and control system. A record may be transferred as many times as possible, until it is overwritten by a new record.

If a record is made by Sepam while the oldest record is being transferred, the oldest record is stopped.

If a command (e.g. remote read or remote setting request) is carried out during the transfer of a disturbance recording record, the record is not disturbed.

Time-setting

Each record can be dated.

Time-setting of Sepam is described in the "Time-tagging of events" section.

Transferring records

Transfer requests are made record by record. A configuration file and a data file are produced for each record.

The master sends the commands to:

- find out the characteristics of the records stored in an identification zone
 - read the contents of the different files
 - acknowledge each transfer
 - reread the identification zone to ensure that the record still appears in the list of records available.
- 2 transfer zones are available:
- transfer zone 1
 - request frame: 2200h-2203h
 - identification zone: starting at 2204h
 - reply frame: starting at 2300h
 - transfer zone 2
 - request frame: 2400h-2403h
 - identification zone: starting at 2404h
 - reply frame: starting at 2500h.

Reading the identification zone

Given the volume of data to be transmitted, the master must ensure that there are data to be recovered and prepare the exchanges when necessary.

The identification zone, described below, is read by the reading of N words starting at the address 2204h/2404h:

- 2 reserve words forced to 0
- size of record configuration files encoded in 1 word
- size of record data files encoded in 2 words
- number of records encoded in 1 word
- date of record 1 (least recent) encoded in 4 words (see format below)
- date of record 2 encoded in 4 words (see format below)
- ...
- date of record 19 (most recent) encoded in 4 words (see format below)
- 27 reserve words.

All of these data are consecutive.

Reading the contents of the different files

Request frame

The master makes the request by writing the date of the record to be transferred (function 16) in 4 words starting at the address 2200h.

It should be noted that requesting a new record amounts to stopping the transfers that are in progress. This is not the case for an identification zone transfer request.

2200h/2400h

B15	B14	B13	B12	B11	B10	B09	B08	B07	B06	B05	B04	B03	B02	B01	B00
O	O	O	O	O	O	O	O	Y	Y	Y	Y	Y	Y	Y	Y
O	O	O	O	M	M	M	M	O	O	O	D	D	D	D	D
O	O	O	H	H	H	H	O	O	mn	mn	mn	mn	mn	mn	mn
ms	ms	ms	ms	ms	ms	ms	ms	ms	ms	ms	ms	ms	ms	ms	ms

Y - 1 byte for years: varies from 0 to 99 years.

The remote monitoring and control system must ensure that the year 00 is later than 99.

M - 1 byte for months: varies from 1 to 12.

D - 1 byte for days: varies from 1 to 31.

H - 1 byte for hours: varies from 0 to 23.

mn - 1 byte for minutes: varies from 0 to 59.

ms - 2 bytes for milliseconds: varies from 0 to 59999.

Reply frame

Reading of each portion of configuration and data file records by a 125-word read frame (function 3) starting at the address 2300h.

2300h/2500h

B15	B14	B13	B12	B11	B10	B09	B08	B07	B06	B05	B04	B03	B02	B01	B00
Exchange number								Number of usable bytes in the data zone							
.....															
Data zone															
.....															

Reading should always begin with the first word in the address zone (any other address triggers an exception reply "incorrect address").

The configuration and data files are read in their entirety in Sepam. They are transferred adjacently.



If the master requests more exchanges than necessary, the exchange number remains unchanged and the number of usable bytes is forced to 0. To guarantee data transfers, it is necessary to allow a response time of about 500 ms between each read operation at 2300h.

The first word transmitted is an exchange word. The exchange word comprises two fields:

- the most significant byte contains the exchange number. It is initialized to zero after an energizing operation. It is incremented by 1 by Sepam each time a transfer takes place successfully. When it reaches the value FF, it automatically goes back to zero

- the least significant byte contains the number of usable bytes in the data zone. It is initialized to zero after an energizing operation and must be different from FFh.

The exchange word may also have the following values:

- **xyyy**: the number of usable bytes in the data zone yy must be different from FFh

- **0000h**: no "read request frame" has yet been formulated.

This is especially the case when Sepam is energized.

The other words are not significant.

- **FFFFh**: the "request frame" has been processed, but the results in the reply zone are not yet available.

It is necessary to repeat "reply frame" reading.

The other words are not significant.

The words that follow the exchange word make up the data zone.

Since the configuration and data files are adjacent, a frame may contain the end of the configuration and the beginning of the data file of a record.

It is up to the remote monitoring and control system software to reconstruct the files in accordance with the transmitted number of usable bytes and the size of the files indicated in the identification zone.

Acknowledging a transfer

To inform Sepam that a record block that it has just read has been received correctly, the master must write the number of the last exchange that it has carried out in the "exchange number" field and set the "number of usable bytes in the data zone" of the exchange word to zero.

Sepam only increments the exchange number if new acquisition bursts are present.

Rereading the identification zone

To ensure that the record has not been modified, during its transfer by a new record, the master rereads the contents of the identification zone and ensures that the date of the recovered record is still present.

Presentation

The "Read Device Identification" function is used to access in a standardized manner the information required to clearly identify a device.

The description is made up of a set of objects (ASCII character strings).

Sepam series 40 accepts the "read identification" function (conformity level 02).

For a complete description of the function, go to www.modbus.org. The description below covers a subset of the function, adapted to Sepam series 40.

Implementation

Request frame

The request frame is made of the following components.

Field	Size (bytes)	
Slave number	1	
43 (2Bh)	1	Generic access function code
14 (0Eh)	1	Read device identification
01 or 02	1	Type of read
00	1	Object number
CRC16	2	

The type of read is used to select a simplified (01) or a standard (02) description.

Reply frame

The reply frame is made of the following components.:

Field	Size (bytes)	
Slave number	1	
43 (2Bh)	1	Generic access function code
14 (0Eh)	1	Read device identification
01 or 02	1	Type of read
02	1	Conformity level
00	1	Continuation-frame flag (none for Sepam)
00	1	Reserved
n	1	Number of objects (according to read type)
Obj1	1	Number of first object
lg1	1	Length first object
txt1	lg1	ASCII string of first object
.....	...	
objn	1	Number n th object
lgn	1	Length n th object
txtn	lgn	ASCII string of n th object
CRC16	2	

Sepam series 40 identification

The objects making up the Sepam series 40 identification are listed below.

Number	Type	Value
0	VendorName	"Merlin Gerin" or "Schneider Electric"
1	ProductCode	Application EAN13 code
2	MajorMinorRevision	Application version number (Vx.yy)
3	VendorURL	"www.schneider-electric.com"
4	ProductName	"Sepam series 40"
5	ModelName	Application name (e.g. "M41 Motor")
6	UserAppName	Sepam marking

Exception frame

If an error occurs during request processing, a special exception frame is sent.

Field	Size (bytes)	
Slave number	1	
171 (ABh)	1	Generic access exception (2Bh + 80h)
14 (0Eh)	1	Read device identification
01 or 03	1	Type of error
CRC16	2	

Safety and Cyber-security instructions	200
Before starting	
Precautions	201
Equipment identification	202
Identification of the base unit	202
Identification of accessories	203
Sepam series 40	204
Base unit	206
Dimensions	206
Assembly	207
Connection	208
Connection of current input	210
Other phase current input connection schemes	211
Other residual current input connection schemes	212
Connection of low voltage residual current inputs	214
Connections of input voltage	216
Connection of low voltage phase voltage inputs	217
1 A/5 A current transformers	218
Voltage transformers	220
LPCT type current sensors	221
CSH120, CSH200, CSH300 Core balance CTs	224
CSH30 interposing ring CT	226
ACE990 Core balance CT interface	228
MES114 modules	230
Optional remote modules	233
Connection	
MET148-2 Temperature sensor module	234
MSA141 Analog output module	236
DSM303 Remote advanced UMI module	238
Communication accessory selection guide	240
Connection of communication interfaces	241
Connection cords	241
Characteristics of communication networks	242
ACE949-2 2-wire RS 485 network interface	243
ACE959 4-wire RS 485 network interface	244
ACE937 fiber optic interface	245
ACE969TP-2 and ACE969FO-2 Multi-protocol interfaces	246
Description	248
Connection	249
ACE850TP and ACE850FO Multi-protocol interfaces	252
Description	254
Connection	255
ACE909-2 RS 232/RS 485 converter	258
ACE919CA and ACE919CC RS 485/RS 485 converters	260
ECI850 IEC 61850 Sepam server	262

This page contains important safety and cyber-security instructions that must be followed precisely before attempting to install, repair, service or maintain electrical equipment. Carefully read and follow the safety and cyber-security instructions described below.

Safety instructions

DANGER

HAZARD OF ELECTRIC SHOCK, ELECTRIC ARC, BURNS OR EXPLOSION

- Only qualified personnel should install this equipment. Such work should be performed only after reading this entire set of instructions.
- NEVER work alone.
- Turn off all power supplying this equipment before working on or inside it.
- Always use a properly rated voltage sensing device to confirm that all power is off.
- Before performing visual inspections, tests, or maintenance on this equipment, disconnect all sources of electric power. Assume that all circuits are live until they have been completely de-energized, tested and tagged. Pay particular attention to the design of the power system. Consider all sources of power, including the possibility of backfeeding.
- Beware of potential hazards, wear personal protective equipment, carefully inspect the work area for tools and objects that may have been left inside the equipment.
- The successful operation of this equipment depends upon proper handling, installation, and operation. Neglecting fundamental installation requirements can lead to personal injury as well as damage to electrical equipment or other property.
- Handling this product requires relevant expertise in the field of protection of electrical networks. Only competent people who have this expertise are allowed to configure and set up this product.
- Before performing Dielectric (Hi-Pot) or Megger testing on any equipment in which the relay is installed, disconnect all input and output wires to the relay. High voltage testing can damage electronic components contained in the Sepam unit.

Failure to follow these instructions will result in death or serious injury.

Cyber security instructions

SEPAM is designed to be operated only on a protected network.
(see document "Recommended Cybersecurity Best Practices"
--> <https://www.se.com/us/en/download/document/7EN52-0390/>)

NOTICE

HAZARD OF DATA TAMPERING OR UNINTENDED OPERATION

- Secure the local network : physically or logically segment the network and restrict access using standard controls such as firewall.
- Enable IP Filtering for Modbus/TCP and IEC61850 (see document "SEPAM IEC61850 communication" SEPED306024 chapter configuration of ACE850 communication interface).
- Inhibit the remote-setting. It is possible to inhibit the remote-setting function using a configuration parameter accessible via SFT2841. In the default set-up (factory settings), the remote-setting function is inhibited.

FAILURE TO FOLLOW THESE INSTRUCTIONS CAN RESULT IN COMPROMISED SECURITY. SCHNEIDER-ELECTRIC MAKES NO WARRANTY THAT THE SEPAM PRODUCTS WILL BE FREE FROM VULNERABILITIES, CORRUPTION, ATTACK, VIRUSES, INTERFERENCE, HACKING OR OTHER SECURITY INTRUSIONS OR CYBER THREATS, AND SCHNEIDER-ELECTRIC DISCLAIMS ANY LIABILITY IN RELATION THERETO.

We recommend that you follow the instructions given in this document for quick, correct installation of your Sepam unit:

- Equipment identification
- Assembly
- Connection of inputs, current, voltage and sensors
- Connection of power supply
- Checking prior to commissioning

Transport, handling and storage

Sepam in its original packaging

Transport:

Sepam can be shipped to any destination by all usual means of transport without taking any additional precautions.

Handling:

Sepam can be handled without any particular care and can even withstand being dropped by a person standing at floor-level.

Storage:

Sepam can be stored in its original packaging, in an appropriate location for several years:

- Temperature between -25°C and +70°C (between -13°F and +158°F)
- Humidity ≤ 90%.

Periodic, yearly checking of the environment and the packaging condition is recommended.

Energize the Sepam for 1 hour:

- every 5 years for a storage temperature < 30 ° C (86 ° F)
- every 3 years for a storage temperature ≥ 30 ° C (86 ° F)
- every 2 years for a storage temperature ≥ 50 ° C (122 ° F)

Once Sepam has been unpacked, it should be energized as soon as possible.

If the storage time has been longer than 2 years, it is advisable to activate each of the output relays 5 times during commissioning (see procedure in chapter "Commissioning - Checking the connection of the logic outputs", page GJ1)

Sepam installed in a cubicle

Transport:

Sepam can be transported by all usual means of transport in the customary conditions used for cubicles. Storage conditions should be taken into consideration for a long period of transport.

Handling:

Should the Sepam fall out of a cubicle, check its condition by visual inspection and energizing.

Storage:

Keep the cubicle protection packing for as long as possible. Sepam, like all electronic units, should not be stored in a damp environment for more than a month. Sepam should be energized as quickly as possible. If this is not possible, the cubicle reheating system should be activated.

Environment of the installed Sepam

Operation in a damp environment

The temperature/relative humidity factors must be compatible with the unit's environmental withstand characteristics.

If the use conditions are outside the normal zone, special arrangements should be made before commissioning, such as air conditioning of the premises.

Operation in a polluted atmosphere

A contaminated industrial atmosphere (such as the presence of chlorine, hydrofluoric acid, sulfur, solvents, etc.) can cause corrosion of the electronic components, in which case environmental control arrangements should be made (such as pressurized premises with filtered air, etc.) before commissioning.

The effect of corrosion on Sepam has been tested according to the IEC 60068-2-60 and EIA 364-65A (See "Environmental Characteristic", page 11).

Identification of the base unit

Each Sepam comes in a single package which contains the base unit and 2 connectors:

- 1 x 20-pin connector (CCA620 or CCA622)
- 1 x 6-pin connector (CCA626 or CCA627)

The other optional accessories such as modules, current input connectors or voltage and cords are supplied in separate packages.

To identify a Sepam, check the 2 labels on the right side panel of the base unit describing the product's functional and hardware features.

■ Hardware reference and designation label

DE00987

59604 **Serial N° 10480001**

Series 40/advanced UMI/24-250V
Séries 40/IHM avancée/24-250V



S10MD Origin: France



59604+01+10480001+C99

Test PASS: 11/30/2010
Operator: C99

User Machine Interface model

■ Software reference and designation label

DE00988

Substation S42 / Sous-station S42 **59682**

English/French series 40 **59615**

Modbus
0031412 C04







S10 XX S20 X33 XXX

Type of application

Working language

} Additional information
(not given systematically)

Identification of accessories

The accessories such as optional modules, current or voltage connectors and connection cords come in separate packages, which are identified by labels.

- Example of MES114 module identification label:

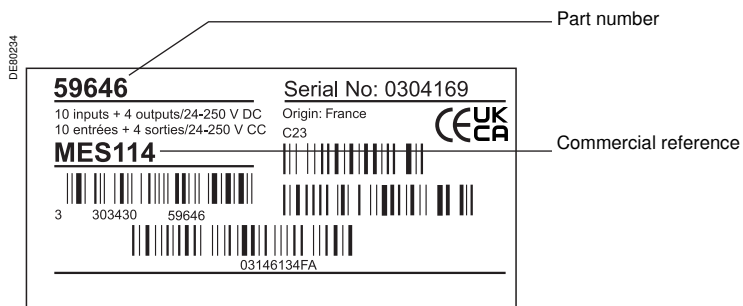

List of Sepam series 40 references

Reference	Description
59600	Base unit with basic UMI, 24-250 V DC and 100-240 V AC power supply
59604	Base unit with advanced UMI, 24-250 V DC and 100-240 V AC power supply
59608	DSM303, remote advanced UMI module
59615	Working language English/French
59616	Working language English/Spanish
59629	CCA634 connector for 1 A/5 A CT + I0 current sensors
59630	CCA630 connector for 1 A/5 A CT current sensors
59631	CCA670 connector for LPCT current sensors
59634	CSH30 interposing ring CT for I0 input
59635	CSH120 residual current sensor, diameter 120 mm (4.75 in)
59636	CSH200 residual current sensor, diameter 196 mm (7.72 in)
59637	CSH300 residual current sensor, diameter 291 mm (11.46 in)
59638	ECI850 IEC 61850 Sepam server with PRI voltage surge arrester
59639	AMT852 lead sealing accessory
59641	MET148-2 8-temperature sensor module
59642	ACE949-2 2-wire RS 485 network interface
59643	ACE959 4-wire RS 485 network interface
59644	ACE937 optical fiber interface
59646	MES114 10 input + 4 output module/24-250 V DC ⁽¹⁾
59647	MSA141 1 analog output module
59648	ACE909-2 RS 485/RS 232 converter
59649	ACE919CA RS 485/RS 485 interface (AC power supply)
59650	ACE919CC RS 485/RS 485 interface (DC power supply)
59651	MES114E 10 input + 4 output module/110-125 V DC and V AC
59652	MES114F 10 input + 4 output module/220-250 V DC and V AC
TCSEAK0100	Ethernet configuration kit for ECI850

(1) Reference 59645 "MES108 module 4I/4O" cancelled and replaced by 59646.

List of Sepam series 40 references

59656	CCA626 6-pin screw type connector
59657	CCA627 6-pin ring lug connector
59658	ACE850TP RJ45 Ethernet multi-protocol interface (IEC 61850, Modbus TCP/IP)
59659	ACE850FO fiber-optic Ethernet multi-protocol interface (IEC 61850, Modbus TCP/IP)
59660	CCA770 remote module connection cord, L = 0.6 m (2 ft)
59661	CCA772 remote module connection cord, L = 2 m (6.6 ft)
59662	CCA774 remote module connection cord, L = 4 m (13.1 ft)
59663	CCA612 communication interface communication cord (except ACE850), L = 3 m (9.8 ft)
59664	CCA783 PC RS 232 port connection cord
59666	CCA613 LPCT test plug
59667	ACE917 LPCT injection adapter
59668	CCA620 20-pin screw type connector
59669	CCA622 20-pin ring lug connector
59670	AMT840 mounting plate
59671	CCA784 PC USB port connection cord
59672	ACE990 core balance CT interface for IO input
59676	Kit 2640 2 sets of spare connectors for MES114
59679	SFT2841 CD-ROM with SFT2841 and SFT2826 software, without CCA783 cord
59680	Substation application type S40
59681	Substation application type S41
59682	Substation application type S42
59683	Transformer application type T40
59684	Transformer application type T42
59685	Motor application type M41
59686	Generator application type G40
59687	Substation application type S43
59688	Substation application type S44
59689	Motor application type M40
59723	ACE969TP-2 2-wire RS 485 multi-protocol interface (Modbus, DNP3 or IEC 60870-5-103) ⁽¹⁾
59724	ACE969FO-2 fiber-optic multi-protocol interface (Modbus, DNP3 or IEC 60870-5-103) ⁽¹⁾
59726	CD SFT850 CD-ROM with IEC 61850 configuration software
59751	CCA614 ACE850 communication interface connection cord, L = 3 m (9.8 ft)
59754	TCP/IP firmware option (mandatory for using ACE850 multi-protocol communication interfaces with Sepam series 40, CCA612 and Sepam series 60 and CCA612 and Sepam series 80).
59780	Substation application type S50
59781	Substation application type S51
59782	Substation application type S52
59783	Substation application type S53
59784	Transformer application type T50
59785	Transformer application type T52
59786	Substation application type S54

(1) Reference 59720 "ACE969TP" cancelled and replaced by 59723, reference 59721 "ACE969FO" cancelled and replaced by 59724.

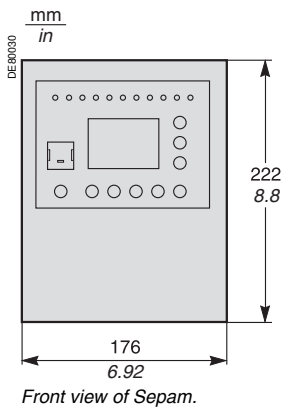

Dimensions

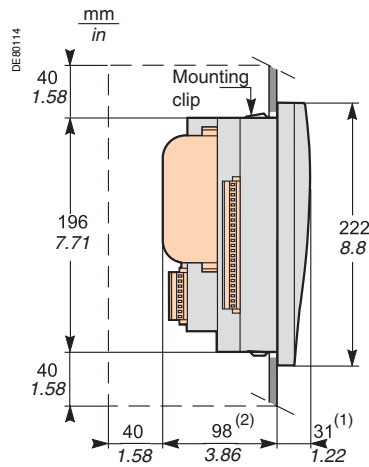

Sepam with advanced UMI and MES114, flush-mounted in front panel.

Clearance for Sepam assembly and wiring.

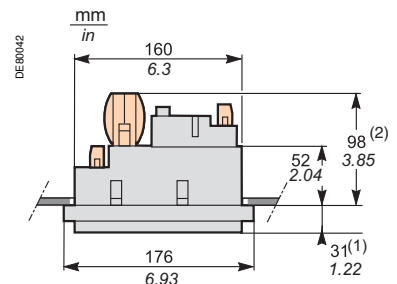

Sepam with advanced UMI and MES114, flush-mounted in front panel.

- (1) With basic UMI: 23 mm (0.91 in).
- (2) With CCA634: 105 mm (4.13 in).

Cut-out

Cut-out accuracy must be complied with to ensure good withstand.

For mounting plate between 1.5 mm (0.059 in) and 3 mm (0.12 in) thick

For mounting plate 3.17 mm (0.125 inch) thick

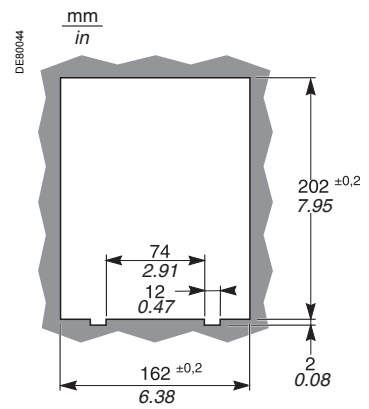
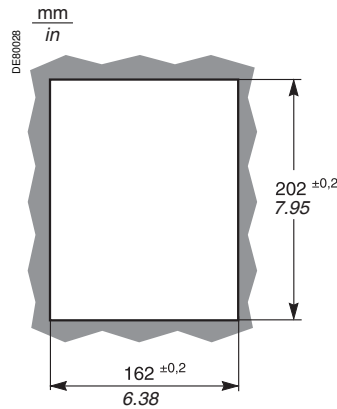

Assembly with AMT840 mounting plate

Used to mount Sepam with basic UMI at the back of the compartment with access to the connectors on the rear panel.

Mounting associated with the use of the remote advanced UMI (DSM303).

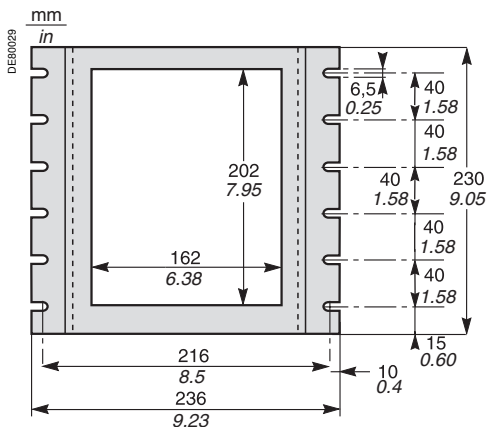

AMT840 mounting plate.

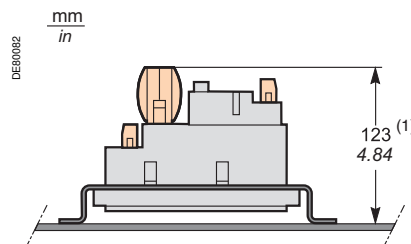

Sepam with basic UMI and MES114, mounted with AMT840 plate. Mounting plate thickness: 2 mm (0.079 in).

- (1) With CCA634: 130 mm (5.12 in).

⚡ ⚠ DANGER

HAZARD OF ELECTRIC SHOCK, ELECTRIC ARC OR BURNS

- Only qualified personnel should install this equipment. Such work should be performed only after reading this entire set of instructions.
- NEVER work alone.
- Turn off all power supplying this equipment before working on or inside it. Consider all sources of power, including the possibility of backfeeding.
- Always use a properly rated voltage sensing device to confirm that all power is off.

Failure to follow these instructions will result in death or serious injury.

The Sepam is simply flush-mounted and secured by its clips. No additional screw type fastening is required.

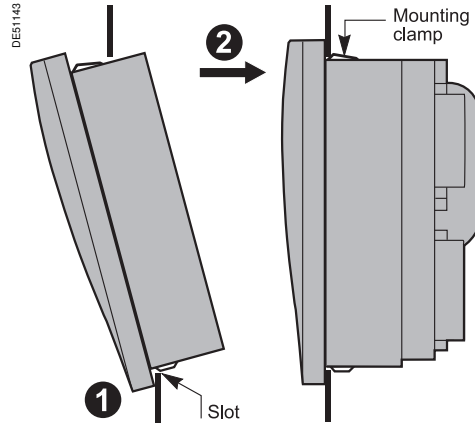

- ① Present the product as indicated, making sure the metal plate is correctly entered in the groove at the bottom.
- ② Tilt the product and press on the top part to clamp it with the clips.

Sepam components

- base unit ①
 - ① base unit connector:
 - power supply
 - output relay
 - CSH30, 120, 200, 300 or ACE990 input.
 - Screw-type connector shown (CCA620), or ring lug connector (CCA622)
 - ② 1/5 CT A current input connector (CCA630 or CCA634) or LPCT current input connector (CCA670)
 - ③ communication module link connection (white)
 - ④ remote inter-module link connection (black)
 - ⑤ voltage input connection, screw-type connector shown (CCA626) or ring lug connector (CCA627)
- optional input/output module ② (MES114)
 - ⑥ MES114 module connectors
 - ⑦ MES114 module connector.

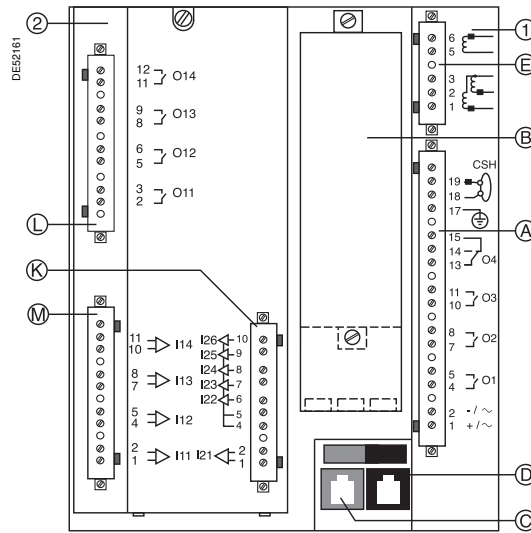

6

Connection of the base unit

The Sepam connections are made to the removable connectors located on the rear panel. All the connectors are screw-lockable.

NOTICE

LOSS OF PROTECTION OR RISK OF NUISANCE TRIPPING

If the Sepam is no longer supplied with power or is in fail-safe position, the protection functions are no longer active and all the Sepam output relays are dropped out. Check that this operating mode and the watchdog relay wiring are compatible with your installation.

Failure to follow these instructions can result in equipment damage and unwanted shutdown of the electrical installation.

⚠ ⚠ DANGER

HAZARD OF ELECTRIC SHOCK, ELECTRIC ARC OR BURNS

- Only qualified personnel should install this equipment. Such work should be performed only after reading this entire set of instructions.
- NEVER work alone.
- Turn off all power supplying this equipment before working on or inside it. Consider all sources of power, including the possibility of backfeeding.
- Always use a properly rated voltage sensing device to confirm that all power is off.
- Start by connecting the device to the protective ground and to the functional ground.
- Screw tight all terminals, even those not in use.

Failure to follow these instructions will result in death or serious injury.

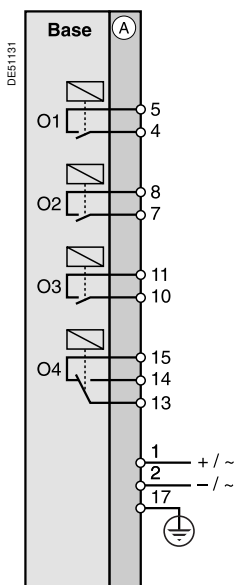

Wiring of connectors CCA620 and CCA626:

- Without fitting:
 - 1 wire with maximum cross-section of 0.2 to 2.5 mm² (≥ AWG 24-12) or 2 wires with maximum cross-section of 0.2 to 1 mm² (≥ AWG 24-16)
 - Stripped length: 8 to 10 mm (0.31 to 0.39 in)
- With fitting:
 - Recommended wiring with Telemecanique fitting:
 - DZ5CE015D for 1 wire 1.5 mm² (AWG 16)
 - DZ5CE025D for 1 wire 2.5 mm² (AWG 12)
 - AZ5DE010D for 2 wires 1 mm² (AWG 18)
 - Tube length: 8.2 mm (0.32 in)
 - Stripped length: 8 mm (0.31 in)

Wiring of connectors CCA622 and CCA627:

- Ring or spade lug: 6.35 mm (1/4")
- Wire with maximum cross-section 0.2 to 2.5 mm² (AWG 24-12)
- Stripped length: 6 mm (0.236 in)
- Use an appropriate tool to crimp the lugs onto the wires
- 2 ring or spade lugs maximum per terminal
- Tightening torque: 0.7 to 1 N•m (6 to 9 lb-in).

Characteristics of the 4 base unit relay outputs O1, O2, O3, O4

- O1 and O2 are 2 control outputs, used by the breaking device control function for:
 - O1: breaking device tripping
 - O2: breaking device closing inhibition
- O3 is a non assigned control output.
- O4 is a non assigned indication output. It can be assigned to the watchdog function.

Base unit

Connection of current input

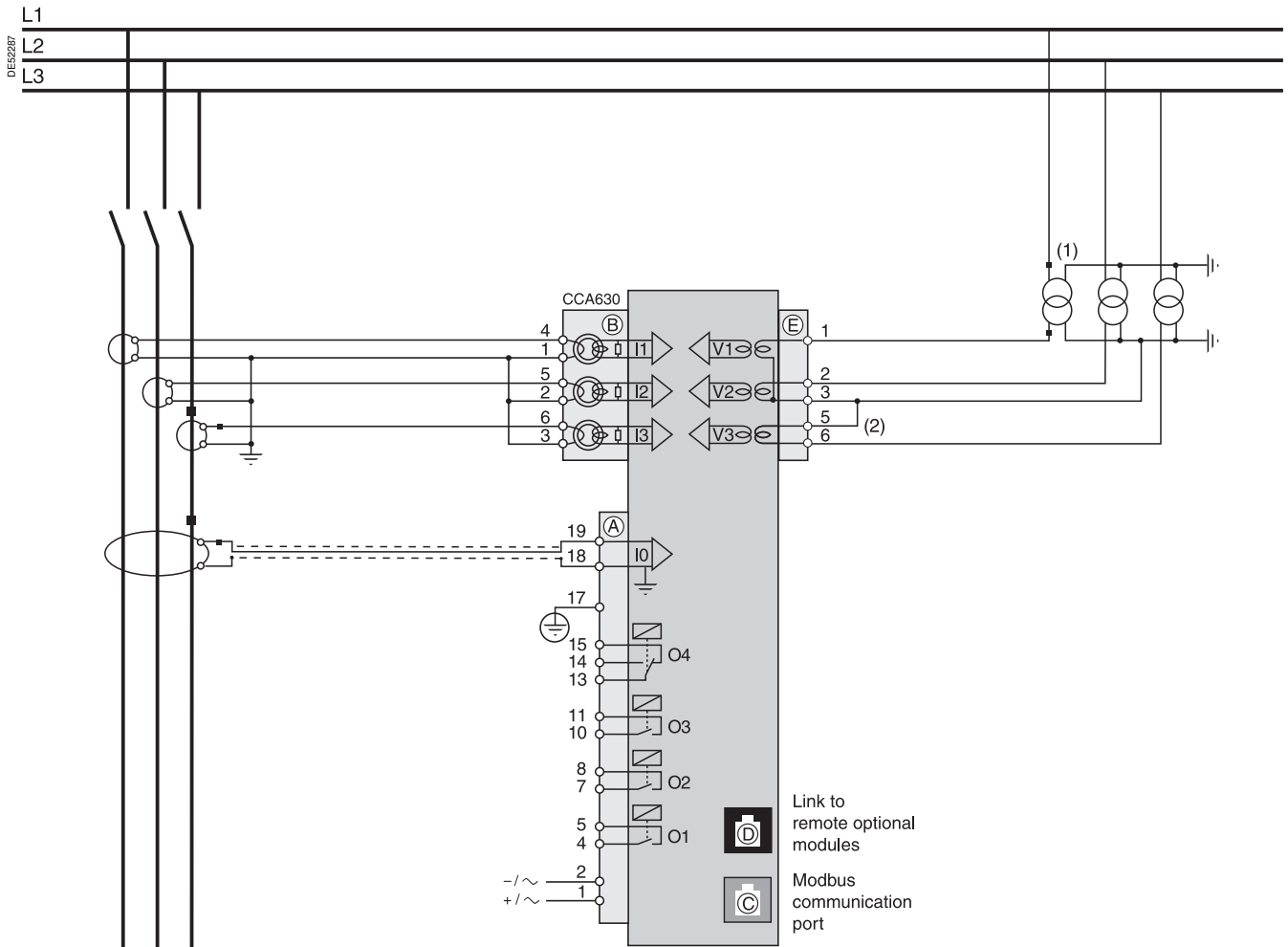

- (1) This type of connection allows the calculation of residual voltage.
 (2) Accessory for bridging terminals 3 and 5 supplied with CCA626 connector.

Base unit

Other phase current input connection schemes

Variant 1: phase current measurements by 3 x 1 A or 5 A CTs (standard connection)

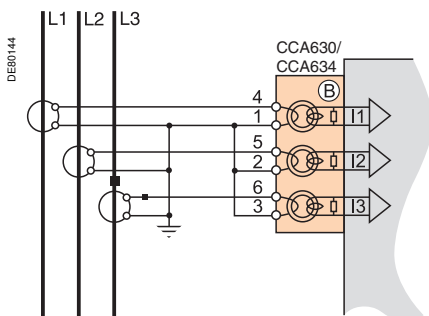

Description

Connection of 3 x 1 A or 5 A sensors to the CCA630 or CCA634 connector.

The measurement of the 3 phase currents allows the calculation of residual current.

Parameters

Sensor type	5 A CT or 1 A CT
Number of CTs	I1, I2, I3
Rated current (In)	1 A to 6250 A

Variant 2: phase current measurement by 2 x 1 A or 5 A CTs

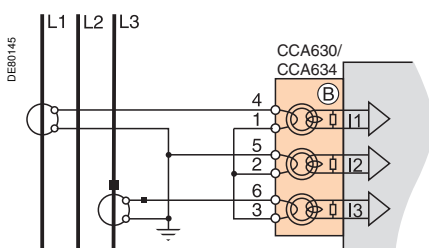

Description

Connection of 2 x 1 A or 5 A sensors to the CCA630 or CCA634 connector.

The measurement of phase currents 1 and 3 is sufficient to ensure all the phase current-based protection functions. The phase current I2 is only assessed for metering functions, assuming that I0 = 0.

This arrangement does not allow the calculation of residual current.

Parameters

Sensor type	5 A CT or 1 A CT
Number of CTs	I1, I3
Rated current (In)	1 A to 6250 A

Variant 3: phase current measurement by 3 LPCT type sensors

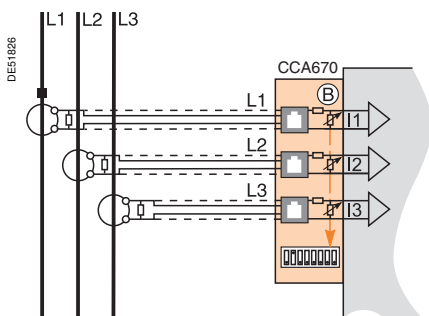

Description

Connection of 3 Low Power Current Transducer (LPCT) type sensors to the CCA670 connector. The connection of only one or two LPCT sensors is not allowed and causes Sepam to go into fail-safe position.

The measurement of the 3 phase currents allows the calculation of residual current.

Parameters

Sensor type	LPCT
Number of CTs	I1, I2, I3
Rated current (In)	25, 50, 100, 125, 133, 200, 250, 320, 400, 500, 630, 666, 1000, 1600, 2000 or 3150 A

Note: Parameter In must be set 2 twice:

- Software parameter setting using the advanced UMI or the SFT2841 software tool
- Hardware parameter setting using microswitches on the CCA670 connector

Base unit

Other residual current input connection schemes

Variant 1: residual current calculation by sum of 3 phase currents

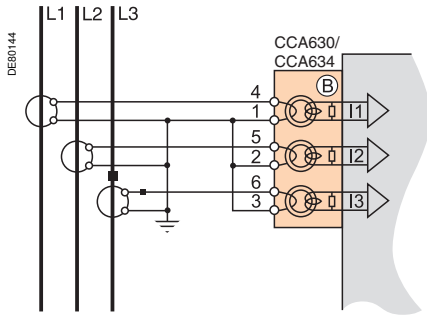

Description

Residual current is calculated by the vector sum of the 3 phase currents I1, I2 and I3, measured by 3 x 1 A or 5 A CTs or by 3 LPCT type sensors. See current input connection diagrams, page 211.

Parameters

Residual current	Rated residual current	Measuring range
None	$I_{n0} = I_n$, CT primary current	0.1 to 40 I_{n0}

Variant 2: residual current measurement by CSH120, CSH200 or CSH300 core balance CT (standard connection)

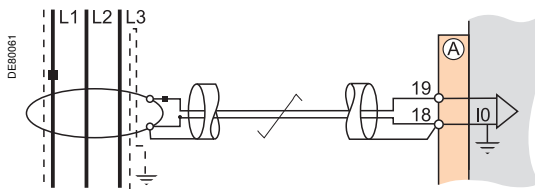

Description

Arrangement recommended for the protection of isolated or compensated neutral systems, in which very low fault currents need to be detected.

Parameters

Residual current	Rated residual current	Measuring range
2 A rating CSH	$I_{n0} = 2$ A	0.2 to 40 A
5 A rating CSH	$I_{n0} = 5$ A	0.5 to 100 A
20 A rating CSH	$I_{n0} = 20$ A	2 to 400 A

Variant 3: residual current measurement by 1 A or 5 A CTs and CCA634

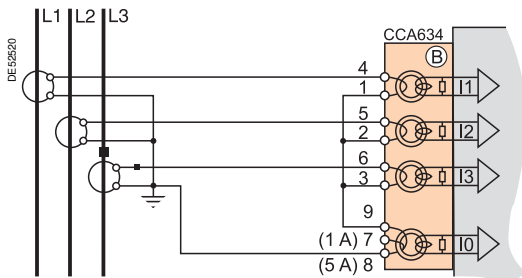

Description

Residual current measurement by 1 A or 5 A CTs.

- Terminal 7: 1 A CT
- Terminal 8: 5 A CT

The sensitivity can be multiplied by 10 using the "sensitive" parameter setting with $I_{n0} = I_n/10$.

Parameters

Residual current	Rated residual current	Measuring range
1 A CT	$I_{n0} = I_n$, CT primary current	0.1 to 20 I_{n0}
Sensitive 1 A CT	$I_{n0} = I_n/10$	0.1 to 20 I_{n0}
5 A CT	$I_{n0} = I_n$, CT primary current	0.1 to 20 I_{n0}
Sensitive 5 A CT	$I_{n0} = I_n/10$	0.1 to 20 I_{n0}

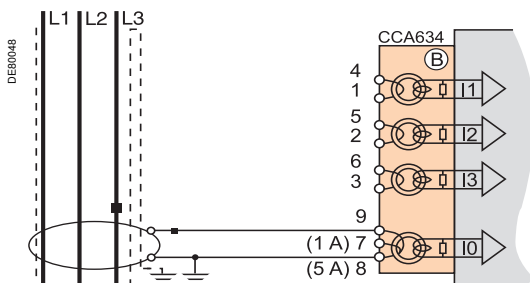

6

Base unit

Other residual current input connection schemes

Variant 4: residual current measurement by 1 A or 5 A CTs and CSH30 interposing ring CT

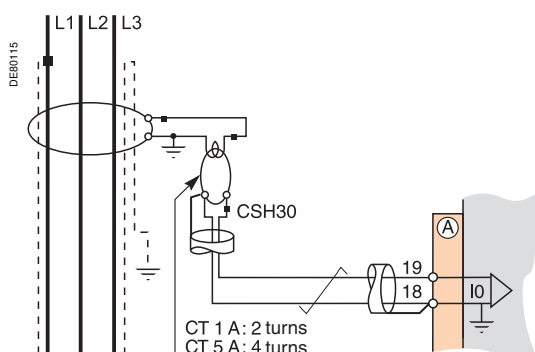

Description

The CSH30 interposing ring CT is used to connect 1 A or 5 A CTs to Sepam to measure residual current:

- Connection of CSH30 interposing ring CT to 1 A CT: make 2 turns through CSH primary
- Connection of CSH30 interposing ring CT to 5 A CT: make 4 turns through CSH primary.

The sensitivity can be multiplied by 10 using the "sensitive" parameter setting with $In0 = In/10$.

Parameters

Residual current	Rated residual current	Measuring range
1 A CT	$In0 = In$, CT primary current	0.1 to 20 $In0$
Sensitive 1 A CT	$In0 = In/10$	0.1 to 20 $In0$
5 A CT	$In0 = In$, CT primary current	0.1 to 20 $In0$
Sensitive 5 A CT	$In0 = In/10$	0.1 to 20 $In0$

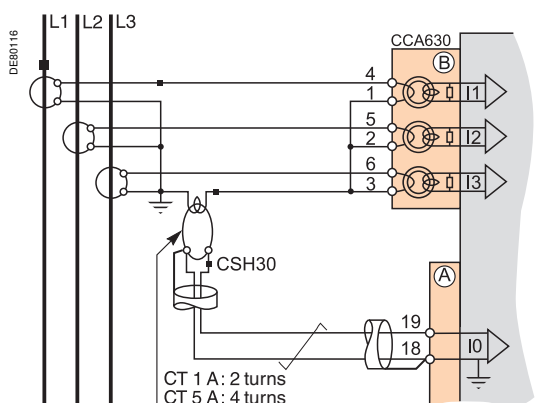

Variant 5: residual current measurement by core balance CT with ratio of 1/n (n between 50 and 1500)

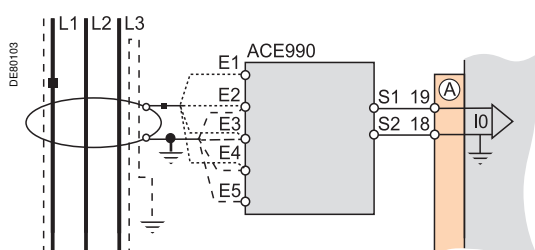

Description

The ACE990 is used as an interface between an MV core balance CT with a ratio of 1/n

($50 < n < 1500$) and the Sepam residual current input.

This arrangement allows the continued use of existing core balance CTs on the installation.

Parameters

Residual current	Rated residual current	Measuring range
ACE990 - range 1	$In0 = Ik.n^{(1)}$	0.1 to 20 $In0$
(0.00578 ≤ k ≤ 0.04)		
ACE990 - range 2	$In0 = Ik.n^{(1)}$	0.1 to 20 $In0$
(0.0578 ≤ k ≤ 0.26316)		

(1) n = number of core balance CT turns

k = factor to be determined according to ACE990 wiring and setting range used by Sepam

Base unit

Connection of low voltage residual current inputs

Variant 1: residual current measurement by CTs on the neutral earthing link (with or without CSH30 interposing ring CT)

Description

Residual current is measured with a 1 A or 5 A CT on the neutral point.

Parameters

Residual current	Rated residual current	Measuring range
1 A CT	$I_{n0} = \text{neutral point CT } I_n$	0.1 to 20 I_{n0}
5 A CT	$I_{n0} = \text{neutral point CT } I_n$	0.1 to 20 I_{n0}

DE80103

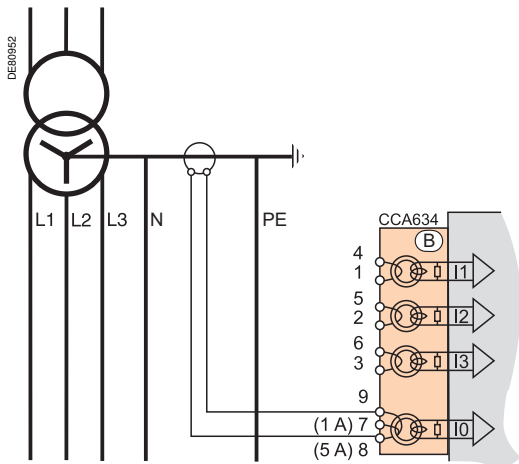

Connection on TN-S network.

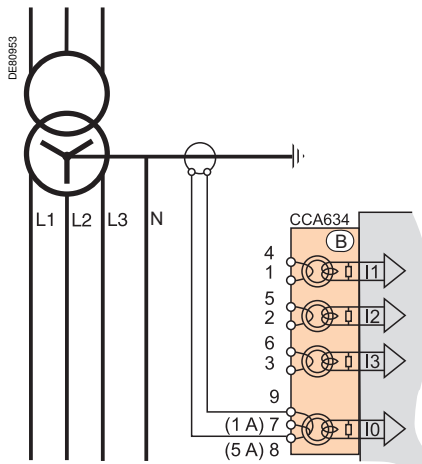

Connection on TT network.

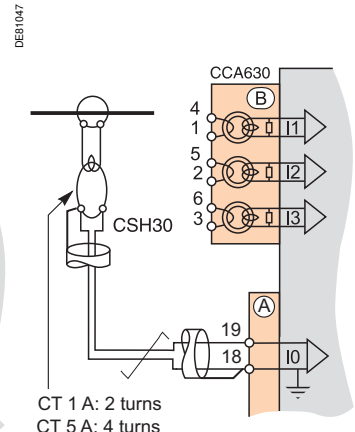

Connection with CSH30.

Variant 2: residual current measurement by CSH120, CSH200 or CSH300 core balance CT on the neutral earthing link

Description

Residual current is measured with a core balance CT on the neutral point. Core balance CTs are recommended for measuring very low fault currents provided that the earth fault current remains below 2 kA. Above this value it is advisable to use the standard variant 1.

Parameters

Residual current	Rated residual current	Measuring range
2 A rating CSH	$I_{n0} = 2 \text{ A}$	0.1 to 20 I_{n0}
5 A rating CSH	$I_{n0} = 5 \text{ A}$	0.1 to 20 I_{n0}
20 A rating CSH	$I_{n0} = 20 \text{ A}$	0.1 to 20 I_{n0}

DE80103

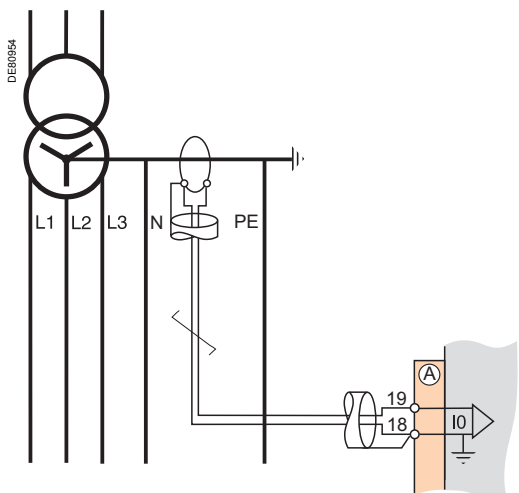

Connection on TN-S network.

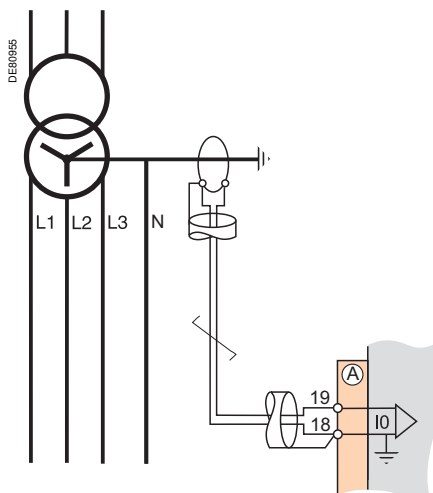

Connection on TT network.

6

Base unit

Connection of low voltage residual current inputs

Variant 3: residual current measurement by sum of 3 phase currents and neutral current measurement by CSH120, CSH200 or CSH300 core balance CT

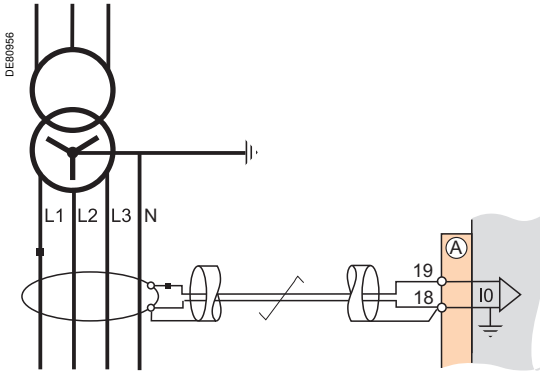

Connection on TN-S and TT networks.

Description

Measurement by core balance CT is recommended for measuring very low fault currents.

Parameters

Residual current	Rated residual current	Measuring range
2 A rating CSH	$I_{n0} = 2 \text{ A}$	0.1 to 20 I_{n0}
5 A rating CSH	$I_{n0} = 5 \text{ A}$	0.1 to 20 I_{n0}
20 A rating CSH	$I_{n0} = 20 \text{ A}$	0.1 to 20 I_{n0}

Variant 4: residual current measurement by sum of 3 phase currents and neutral current measurement by 1 A or 5 A CTs and CSH30 interposing ring CT

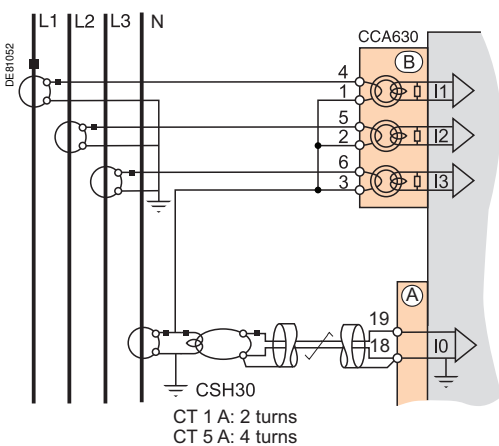

Connection on TN-S and TT networks.

Description

The phase and neutral CTs should have the same primary and secondary currents. The CSH30 interposing ring CT is used to connect 1 A or 5 A CTs to Sepam to measure residual current:

- Connection of CSH30 interposing ring CT to 1 A CT: make 2 turns through CSH primary
- Connection of CSH30 interposing ring CT to 5 A CT: make 4 turns through CSH primary.

Parameters

Residual current	Rated residual current	Measuring range
1 A CT	$I_{n0} = \text{phase CT primary current } I_n$	0.1 to 20 I_{n0}
5 A CT	$I_{n0} = \text{phase CT primary current } I_n$	0.1 to 20 I_{n0}

Variant 5: residual current measurement by sum of 3 phase currents and neutral current measurement by 1 A or 5 A CTs and CCA634 connector

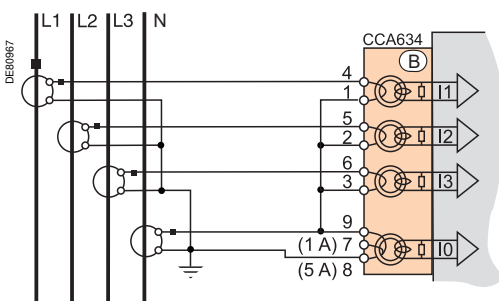

Connection on TN-S and TT networks.

Description

The phase and neutral CTs should have the same primary and secondary currents. Residual current measurement by 1 A or 5 A CTs.

- Terminal 7: 1 A CT
- Terminal 8: 5 A CT

Parameters

Residual current	Rated residual current	Measuring range
1 A CT	$I_{n0} = \text{phase CT primary current } I_n$	0.1 to 20 I_{n0}
5 A CT	$I_{n0} = \text{phase CT primary current } I_n$	0.1 to 20 I_{n0}

The phase and residual voltage transformer secondary circuits are connected directly to the connector, item (E).

The 3 impedance matching and isolation transformers are integrated in the base unit of Sepam series 40.

Variant 1: measurement of 3 phase-to-neutral voltages (standard connection)

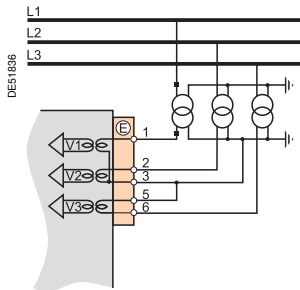

Parameters

Voltages measured by VTs	V1, V2, V3
Residual voltage	None

Functions available

Voltages measured	V1, V2, V3
Values calculated	U21, U32, U13, V0, Vd, Vi, f
Measurements available	All
Protection functions available (according to type of Sepam)	All

Variant 2: measurement of 2 phase-to-phase voltages and residual voltage

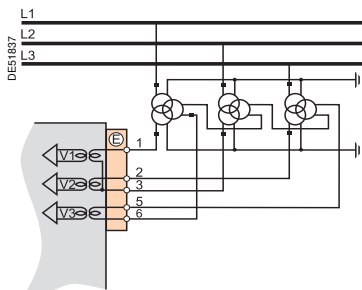

Parameters

Voltages measured by VTs	U21, U32
Residual voltage	External VT

Functions available

Voltages measured	U21, U32, V0
Values calculated	U13, V1, V2, V3, Vd, Vi, f
Measurements available	All
Protection functions available (according to type of Sepam)	All

Variant 3: measurement of 2 phase-to-phase voltages

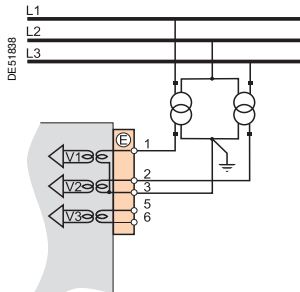

Parameters

Voltages measured by VTs	U21, U32
Residual voltage	None

Functions available

Voltages measured	U21, U32
Values calculated	U13, Vd, Vi, f
Measurements available	U21, U32, U13, Vd, Vi, f
Protection functions available (according to type of Sepam)	All except 67N/67NC, 59N

Variant 4: measurement of 1 phase-to-phase voltage and residual voltage

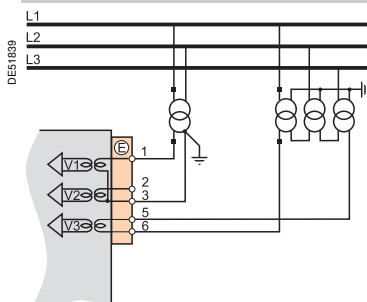

Parameters

Voltages measured by VTs	U21 or V1
Residual voltage	External VT

Functions available

Voltages measured	U21, V0
Values calculated	f
Measurements available	U21, V0, f
Protection functions available (according to type of Sepam)	All except 67, 47, 27D, 32P, 32Q/40, 27S

Variant 5: measurement of 1 phase-to-phase voltage

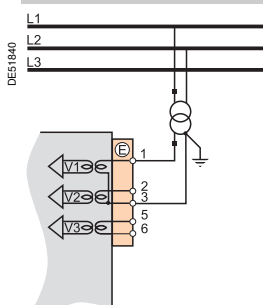

Parameters

Voltages measured by VTs	U21 or V1
Residual voltage	None

Functions available

Voltages measured	U21 or V1
Values calculated	f
Measurements available	U21 or V1, f
Protection functions available (according to type of Sepam)	All except 67, 47, 27D, 32P, 32Q/40, 67N/67NC, 59N, 27S

Base unit

Connection of low voltage phase voltage inputs

Variant 1: TN-S and TN-C networks

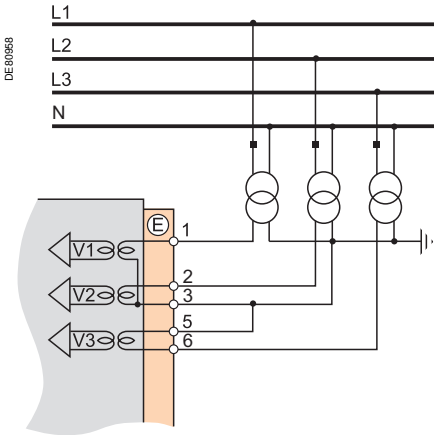

When a ground fault occurs on a TN-S or TN-C network, the neutral potential is not affected: the neutral can act as a reference for the VTs.

Variant 2: TT and IT networks

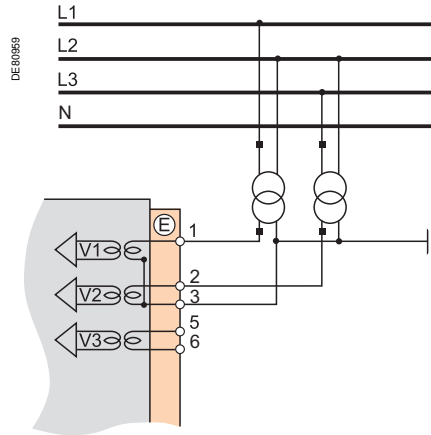

When a ground fault occurs on a TT or IT network, the neutral potential is affected: the neutral cannot act as a reference for the VTs, phase-to-phase voltages must be used on both phases.



ARJA1.



ARJP3.

Function

Sepam may be connected to any standard 1 A and 5 A current transformer. Schneider Electric offers a range of current transformers to measure primary currents from 50 A to 2500 A. Please consult us for further information.

Sizing of current transformers

Current transformers should be dimensioned so as not to become saturated by the current values they are required to measure accurately (minimum 5 In).

For overcurrent protection

- Definite time:
The saturation current must be more than 1.5 times the setting value.
- IDMT:
The saturation current must be more than 1.5 times the highest working value on the curve.

Practical solution when there is no information on the settings

Rated secondary current In	Rated burden	Accuracy class	CT secondary resistance R _{CT}	Wiring resistance R _f
1 A	2.5 VA	5P 20	< 3 Ω	< 0.075 Ω
5 A	7.5 VA	5P 20	< 0.2 Ω	< 0.075 Ω

CCA630/CCA634 connector

Function

The current transformers (1 A or 5 A) are connected to the CCA630 or CCA634 connector on the rear panel of Sepam:

- The CCA630 connector is used to connect 3 phase current transformers to Sepam
- The CCA634 connector is used to connect 3 phase current transformers and a residual current transformer to Sepam.

The CCA630 and CCA634 connectors contain interposing ring CTs with through primaries, which ensure impedance matching and isolation between the 1 A or 5 A circuits and Sepam when measuring phase and residual currents.

The connectors can be disconnected with the power on since disconnection does not open the CT secondary circuit.

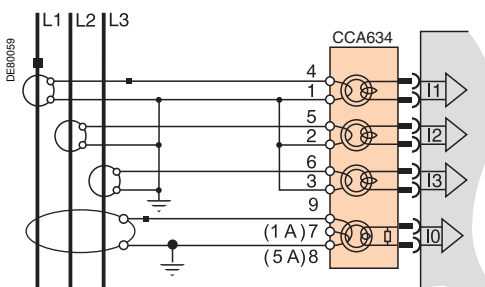
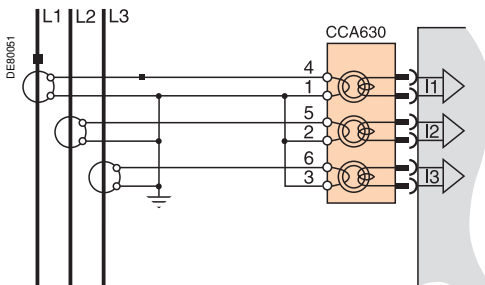

⚠ ⚠ DANGER

HAZARD OF ELECTRIC SHOCK, ELECTRIC ARC OR BURNS

- Only qualified personnel should install this equipment. Such work should be performed only after reading this entire set of instructions and checking the technical characteristics of the device.
- NEVER work alone.
- Turn off all power supplying this equipment before working on or inside it. Consider all sources of power, including the possibility of backfeeding.
- Always use a properly rated voltage sensing device to confirm that all power is off.
- To remove current inputs to the Sepam unit, unplug the CCA630 or CCA634 connector without disconnecting the wires from it. The CCA630 and CCA634 connectors ensure continuity of the current transformer secondary circuits.
- Before disconnecting the wires connected to the CCA630 or CCA634 connector, short-circuit the current transformer secondary circuits.

Failure to follow these instructions will result in death or serious injury.

6

MT10480



Connecting and assembling the CCA630 connector

1. Open the 2 side shields for access to the connection terminals. The shields can be removed, if necessary, to make wiring easier. If removed, they must be replaced after wiring.
2. If necessary, remove the bridging strap linking terminals 1, 2 and 3. This strap is supplied with the CCA630.
3. Connect the wires using 4 mm (0.16 in) ring lugs and check the tightness of the 6 screws that guarantee the continuity of the CT secondary circuits. The connector accommodates wires with cross-sections of 1.5 to 6 mm² (AWG 16-10).
4. Close the side shields.
5. Plug the connector into the 9-pin inlet on the rear panel (item **B**).
6. Tighten the 2 CCA630 connector fastening screws on the rear panel of Sepam.

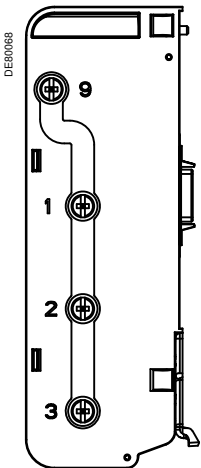

Bridging of terminals 1, 2, 3 and 9

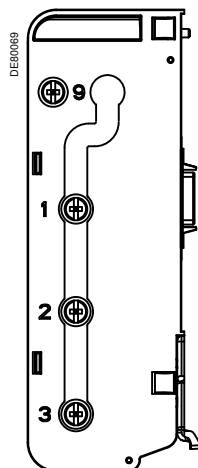

Bridging of terminals 1, 2 and 3

Connecting and assembling the CCA634 connector

1. Open the 2 side shields for access to the connection terminals. The shields can be removed, if necessary, to make wiring easier. If removed, they must be replaced after wiring.
2. According to the wiring required, remove or reverse the bridging strap. This is used to link either terminals 1, 2 and 3, or terminals 1, 2, 3 and 9 (see picture opposite).
3. Use terminal 7 (1 A) or 8 (5 A) to measure the residual current according to the CT secondary.
4. Connect the wires using 4 mm (0.16 in) ring lugs and check the tightness of the 6 screws that guarantee the continuity of the CT secondary circuits. The connector accommodates wires with cross-sections of 1.5 to 6 mm² (AWG 16-10). The wires only exit from the base.
5. Close the side shields.
6. Insert the connector pins into the slots on the base unit.
7. Flatten the connector against the unit to plug it into the 9-pin SUB-D connector (principle similar to that of the MES module).
8. Tighten the mounting screw.

NOTICE

HAZARD OF IMPROPER OPERATION

Do not use a CCA634 on connector B1 and residual current input I0 on connector A (terminals 18 and 19) simultaneously. Even if it is not connected to a sensor, a CCA634 will disturb input I0 on connector A.

Failure to follow these instructions can result in equipment damage.

⚠️ ⚠️ DANGER

HAZARD OF ELECTRIC SHOCK, ELECTRIC ARC OR BURNS

- Only qualified personnel should install this equipment. Such work should be performed only after reading this entire set of instructions and checking the technical characteristics of the device.
- NEVER work alone.
- Turn off all power supplying this equipment before working on or inside it. Consider all sources of power, including the possibility of backfeeding.
- Always use a properly rated voltage sensing device to confirm that all power is off.
- Start by connecting the device to the protective ground and to the functional ground.
- Screw tight all terminals, even those not in use.
- **Failure to follow these instructions will result in death or serious injury.**

The phase and residual voltage transformer secondary circuits are connected to the connector, item (E).

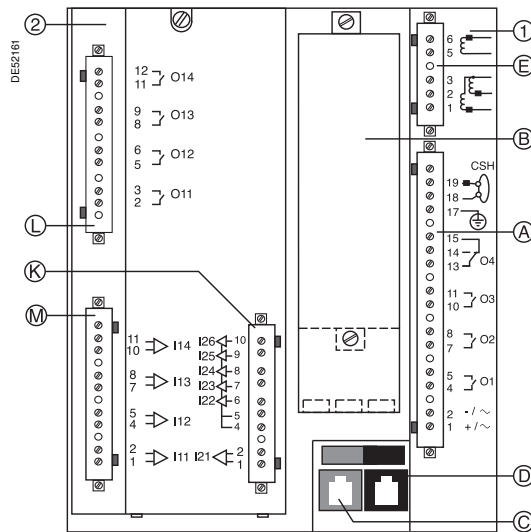

Connections

Connections are made using the screw connectors (CCA626) or ring lug connectors (CCA627) that can be accessed on the rear panel.

Wiring of the CCA626 connector:

- Without fitting:
 - 1 wire with maximum cross-section of 0.2 to 2.5 mm² (≥ AWG 24-12) or 2 wires with maximum cross-section of 0.2 to 1 mm² (≥ AWG 24-16)
 - Stripped length: 8 to 10 mm (0.31 to 0.39 in)
- With fitting:
 - Recommended wiring with Telemecanique fitting:
 - DZ5CE015D for 1 wire 1.5 mm² (AWG 16)
 - DZ5CE025D for 1 wire 2.5 mm² (AWG 12)
 - AZ5DE010D for 2 wires 1 mm² (AWG 18)
 - Tube length: 8.2 mm (0.32 in)
 - Stripped length: 8 mm (0.31 in)

Wiring of the CCA627 connector:

- Ring or spade lug: 6.35 mm (1/4")
- Wire with maximum cross-section 0.2 to 2.5 mm² (AWG 24-12)
- Stripped length: 6 mm (0.236 in)
- Use an appropriate tool to crimp the lugs onto the wires
- 2 ring or spade lugs maximum per terminal
- Tightening torque: 0.7 to 1 N•m (6 to 9 lb-in).



CLP1 LPCT sensor

Function

Low Power Current Transducer (LPCT) type sensors are voltage-output sensors, which are compliant with the IEC 60044-8 standard.
The Schneider Electric range of LPCTs includes the following sensors: CLP1, CLP2, CLP3, TLP130, TLP160 and TLP190.

CCA670/CCA671 connector

Function

The 3 LPCT sensors are connected to the CCA670 or CCA671 connector on the rear panel of Sepam.

The connection of only one or two LPCT sensors is not allowed and causes Sepam to go into fail-safe position.

The two CCA670 and CCA671 interface connectors serve the same purpose, the difference being the position of the LPCT sensor plugs:

- CCA670: lateral plugs, for Sepam series 20 and Sepam series 40
- CCA671: radial plugs, for Sepam series 60 and Sepam series 80.

Description

- 1 3 RJ45 plugs to connect the LPCT sensors.
- 2 3 blocks of microswitches to set the CCA670/CCA671 to the rated phase current value.
- 3 Microswitch setting/selected rated current equivalency table (2 In values per position).
- 4 9-pin sub-D connector to connect test equipment (ACE917 for direct connector or via CCA613).

Rating of CCA670/CCA671 connectors

The CCA670/CCA671 connector must be rated according to the rated primary current I_n measured by the LPCT sensors. I_n is the current value that corresponds to the rated secondary current of 22.5 mV. The possible settings for I_n are (in A): 25, 50, 100, 125, 133, 200, 250, 320, 400, 500, 630, 666, 1000, 1600, 2000, 3150.

The selected I_n value should be:

- entered as a Sepam general setting
- configured by microswitch on the CCA670/CCA671 connector.

Operating mode:

1. Use a screwdriver to remove the shield located in the "LPCT settings" zone; the shield protects 3 blocks of 8 microswitches marked L1, L2, L3.
2. On the L1 block, set the microswitch for the selected rated current to "1" (2 In values per microswitch).
 - The table of equivalencies between the microswitch settings and the selected rated current I_n is printed on the connector
 - Leave the 7 other microswitches set to "0".
3. Set the other 2 blocks of switches L2 and L3 to the same position as the L1 block and close the shield.

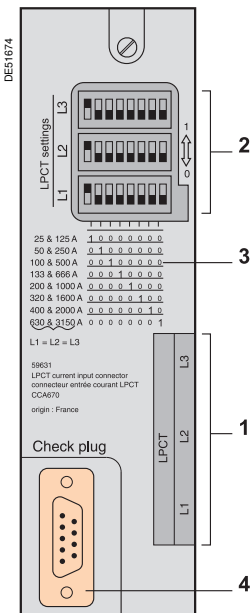

NOTICE

HAZARD OF NON-OPERATION

- Set the microswitches for the CCA670/CCA671 connector before commissioning the device.
- Check that only one microswitch is in position 1 for each block L1, L2, L3 and that no microswitch is in the center position.
- Check that the microswitch settings on all 3 blocks are identical.

Failure to follow these instructions can result in equipment damage.

Accessory connection principle

⚠ ⚠ DANGER

HAZARD OF ELECTRIC SHOCK, ELECTRIC ARC OR BURNS

- Only qualified personnel should install this equipment. Such work should be performed only after reading this entire set of instructions.
- NEVER work alone.
- Turn off all power supplying this equipment before working on or inside it. Consider all sources of power, including the possibility of backfeeding.
- Always use a properly rated voltage sensing device to confirm that all power is off.

Failure to follow these instructions will result in death or serious injury.

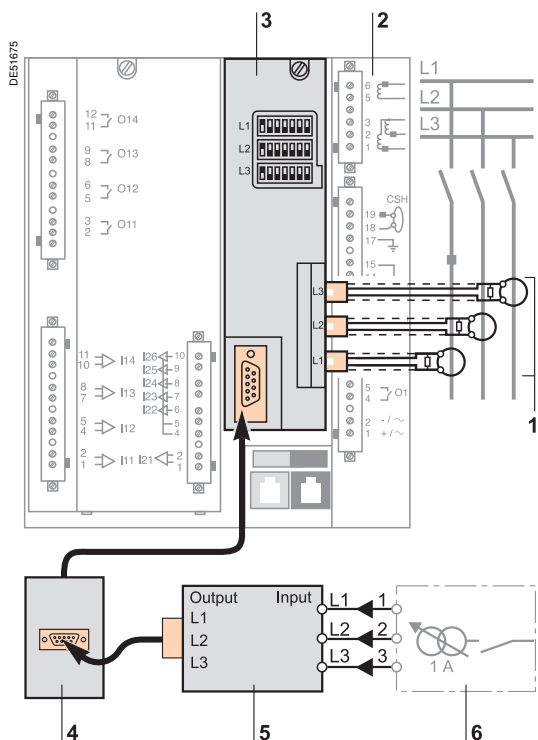

- 1 LPCT sensor, equipped with a shielded cable fitted with a yellow RJ 45 plug which is plugged directly into the CCA670/CCA671 connector.
- 2 Sepam protection unit.
- 3 CCA670/CCA671 connector, LPCT voltage interface, with microswitch setting of rated current:
 - CCA670: lateral plugs for Sepam series 20 and Sepam series 40
 - CCA671: radial plugs for Sepam series 60 and Sepam series 80.
- 4 CCA613 remote test plug, flush-mounted on the front of the cubicle and equipped with a 3-meter (9.8 ft) cord to be plugged into the test plug of the CCA670/CCA671 interface connector (9-pin sub-D).
- 5 ACE917 injection adapter, to test the LPCT protection chain with a standard injection box.
- 6 Standard injection box.

6

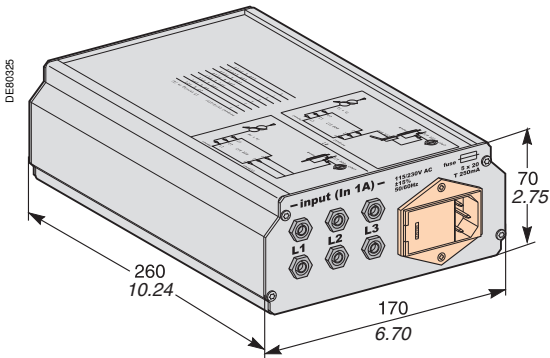

ACE917 injection adapter

Function

The ACE917 adapter is used to test the protection chain with a standard injection box, when Sepam is connected to LPCT sensors.

The ACE917 adapter is inserted between:

- The standard injection box
- The LPCT test plug:
 - integrated in the Sepam CCA670/CCA671 interface connector
 - or transferred by means of the CCA613 accessory.

The following are supplied with the ACE917 injection adapter:

- Power supply cord
- 3-meter (9.8 ft) cord to connect the ACE917 to the LPCT test plug on CCA670/CCA671 or CCA613.

Characteristics

Power supply	115/230 V AC
Protection by time-delayed fuse 5 mm x 20 mm (0.2 x 0.79 in)	0.25 A rating

CCA613 remote test plug

Function

The CCA613 test plug, flush-mounted on the front of the cubicle, is equipped with a 3-meter (9.8 ft) cord to transfer data from the test plug integrated in the CCA670/CCA671 interface connector on the rear panel of Sepam.

Dimensions

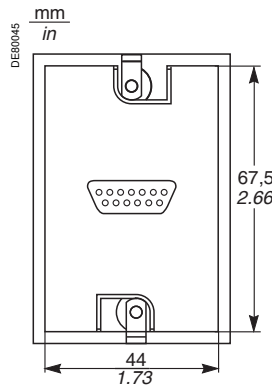

Front view with cover lifted.

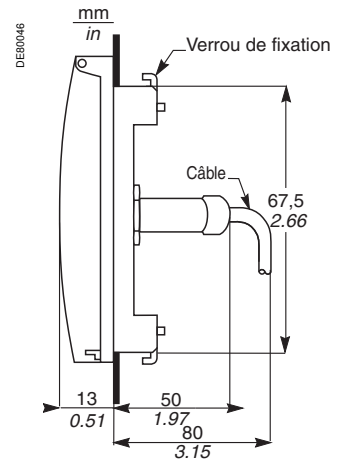

Right side view.

⚠ CAUTION

HAZARD OF CUTS
Trim the edges of the cut-out plates to remove any jagged edges.
Failure to follow these instructions can result in injury.

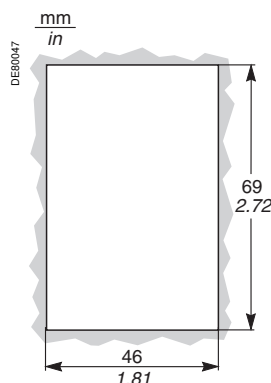

Cut-out.

PE60032



CSH120 and CSH200 core balance CTs.

Function

The specifically designed CSH120, CSH200 and CSH300 core balance CTs are for direct residual current measurement. The only difference between them is the diameter.

Due to their low voltage insulation, they can only be used on cables.

Note:

■ You must use an interface ACE990 with a core balance CT other than a CSH120, a CSH200 or a CSH300, even if this core balance CT has the same transformation ratio than a CSH120, a CSH200 or a CSH300.

Characteristics

		CSH120	CSH200	CSH300
Inner diameter		120 mm (4.7 in)	196 mm (7.72 in)	291 mm (11.46 in)
Weight		0.6 kg (1.32 lb)	1.4 kg (3.09 lb)	2.4 Kg (5.29 lb)
Accuracy	1 CT	±5% at 20°C (68°F)		
	2 CTs in parallel	±6% max. from -25°C to 70°C (-13°F to +158°F)		
Transformation ratio		1/470		
Maximum permissible current	1 CT	20 kA - 1 s		
	2 CTs in parallel	-	6 kA - 1 s	-
Operating temperature		-25°C to +70°C (-13°F to +158°F)		
Storage temperature		-40°C to +85°C (-40°F to +185°F)		

Dimensions

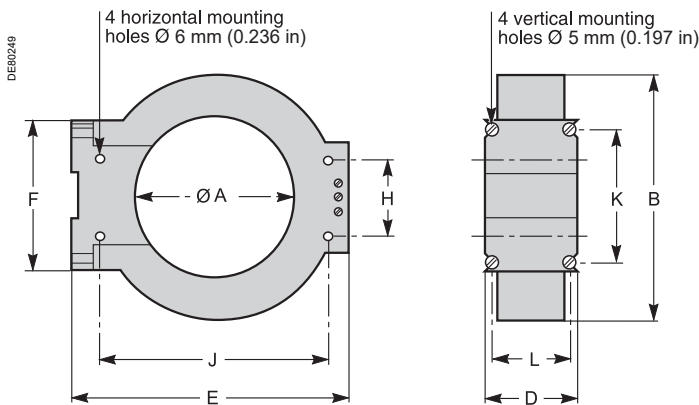

Dimensions	A	B	D	E	F	H	J	K	L
CSH120 (in)	120 (4.75)	164 (6.46)	44 (1.73)	190 (7.48)	80 (3.15)	40 (1.57)	166 (6.54)	65 (2.56)	35 (1.38)
CSH200 (in)	196 (7.72)	256 (10.1)	46 (1.81)	274 (10.8)	120 (4.72)	60 (2.36)	254 (10)	104 (4.09)	37 (1.46)
CSH300 (in)	291 (11.46)	360 (14.17)	46 (1.81)	390 (15.35)	120 (4.72)	60 (2.36)	369 (14.53)	104 (4.09)	37 (1.46)

⚠️ ⚠️ DANGER

HAZARD OF ELECTRIC SHOCK, ELECTRIC ARC OR BURNS

- Only qualified personnel should install this equipment. Such work should be performed only after reading this entire set of instructions and checking the technical characteristics of the device.
- NEVER work alone.
- Turn off all power supplying this equipment before working on or inside it. Consider all sources of power, including the possibility of backfeeding.
- Always use a properly rated voltage sensing device to confirm that all power is off.
- Only CSH120, CSH200 or CSH300 core balance CTs can be used for direct residual current measurement. Other residual current sensors require the use of an intermediate device, CSH30, ACE990 or CCA634.
- Install the core balance CTs on insulated cables.
- Cables with a rated voltage of more than 1000 V must also have an earthed shielding.

Failure to follow these instructions will result in death or serious injury.

Assembly

Group the MV cable (or cables) in the middle of the core balance CT.
Use non-conductive binding to hold the cables.
Remember to insert the 3 medium voltage cable shielding earthing cables through the core balance.

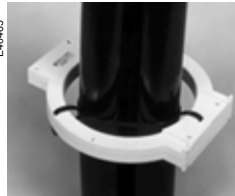
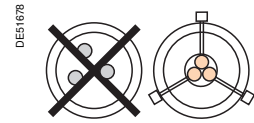

Assembly on MV cables.



Assembly on mounting plate.

NOTICE

HAZARD OF NON-OPERATION

Do not connect the secondary circuit of the CSH core balance CTs to earth.
This connection is made in Sepam.

Failure to follow these instructions can result in equipment damage.

Connection

Connection to Sepam series 20 and Sepam series 40

To residual current I0 input, on connector (A), terminals 19 and 18 (shielding).

Connection to 9UgYf[miSepam series 60

To residual current I0 input, on connector (E), terminals 15 and 14 (shielding).

Connection to 9UgYf[miSepam series 80

- To residual current I0 input, on connector (E), terminals 15 and 14 (shielding)
- To residual current I'0 input, on connector (E), terminals 18 and 17 (shielding).

Recommended cable

- Sheathed cable, shielded by tinned copper braid
- Minimum cable cross-section 0.93 mm² (AWG 18)
- Resistance per unit length < 100 mΩ/m (30.5 mΩ/ft)
- Minimum dielectric strength: 1000 V (700 Vrms)
- Connect the cable shielding in the shortest manner possible to Sepam
- Flatten the connection cable against the metal frames of the cubicle.

The connection cable shielding is grounded in Sepam. Do not ground the cable by any other means.

The maximum resistance of the Sepam connection wiring must not exceed 4 Ω (i.e. 20 m maximum for 100 mΩ/m or 66 ft maximum for 30.5 mΩ/ft).

Connecting 2 CSH200 CTs in parallel

It is possible to connect 2 CSH200 CTs in parallel if the cables will not fit through a single CT, by following the instructions below:

- Fit one CT per set of cables.
- Make sure the wiring polarity is correct.

The maximum permissible current at the primary is limited to 6 kA - 1 s for all cables.

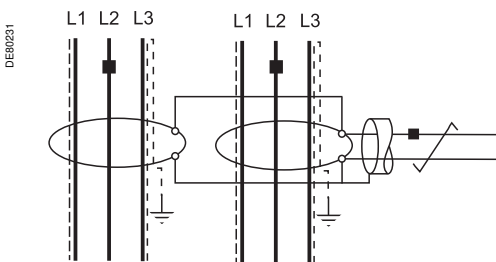
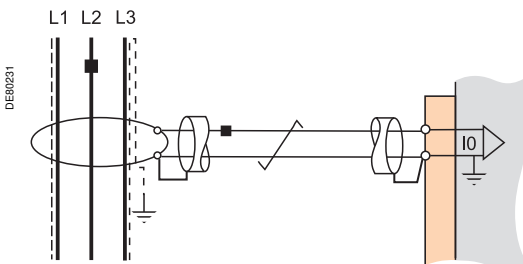



Vertical assembly of CSH30 interposing ring CT.

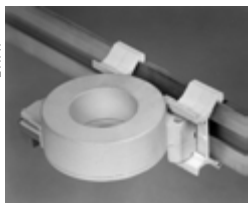

Horizontal assembly of CSH30 interposing ring CT.

Function

The CSH30 interposing ring CT is used as an interface when the residual current is measured using 1 A or 5 A current transformers.

Characteristics

Weight	0.12 kg (0.265 lb)
Assembly	On symmetrical DIN rail In vertical or horizontal position

Dimensions

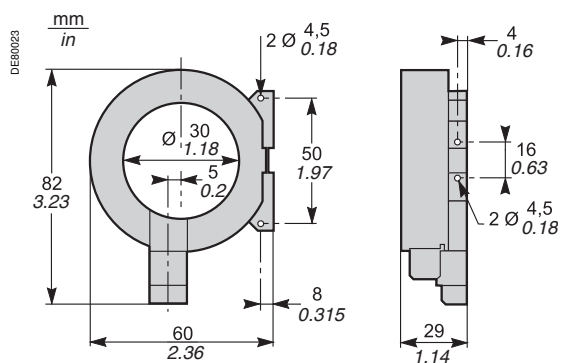

Connection

The CSH30 is adapted for the type of current transformer, 1 A or 5 A, by the number of turns of the secondary wiring through the CSH30 interposing ring CT:

- 5 A rating - 4 turns
- 1 A rating - 2 turns

Connection to 5 A secondary circuit

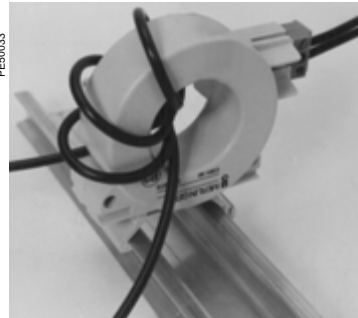

1. Plug into the connector.
2. Insert the transformer secondary wire through the CSH30 interposing ring CT 4 times.

Connection to 1 A secondary circuit

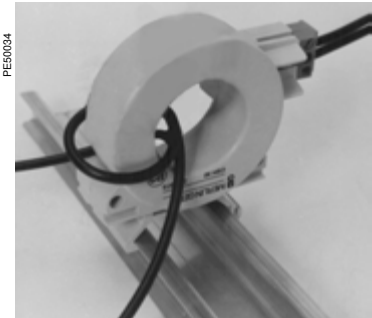

1. Plug into the connector.
2. Insert the transformer secondary wire through the CSH30 interposing ring CT twice.

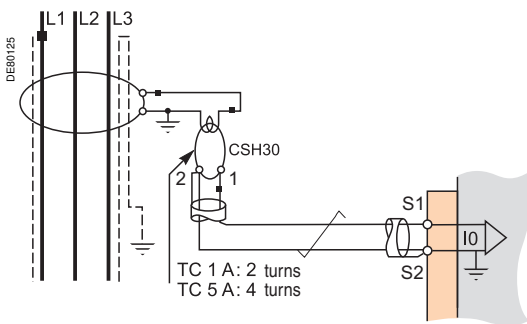

Connection to Sepam series 20 and Sepam series 40

To residual current I0 input, on connector (A), terminals 19 and 18 (shielding).

Connection to 9 UqYf[miSepam series 60

To residual current I0 input, on connector (E) terminals 15 and 14 (shielding).

Connection to 9 UqYf[miSepam series 80

- To residual current I0 input, on connector (E), terminals 15 and 14 (shielding)
- To residual current I'0 input, on connector (E), terminals 18 and 17 (shielding).

Recommended cable

- Sheathed cable, shielded by tinned copper braid
- Minimum cable cross-section 0.93 mm² (AWG 18) (max. 2.5 mm², AWG 12)
- Resistance per unit length < 100 mΩ/m (30.5 mΩ/ft)
- Minimum dielectric strength: 1000 V (700 Vrms)
- Maximum length: 2 m (6.6 ft).

It is essential for the CSH30 interposing ring CT to be installed near Sepam (Sepam - CSH30 link less than 2 m (6.6 ft) long).

Flatten the connection cable against the metal frames of the cubicle.

The connection cable shielding is grounded in Sepam. Do not ground the cable by any other means.

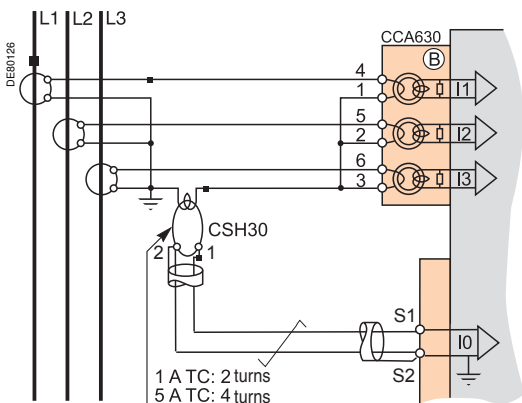



ACE990 core balance CT interface.

Function

The ACE990 is used to adapt measurements between an MV core balance CT with a ratio of 1/n ($50 \leq n \leq 1500$), and the Sepam residual current input.

Note: You must use an interface ACE990 with a core balance CT other than a CSH120, CSH200 or a CSH300, even if this core balance CT has the same transformation ratio than a CSH120, CSH200 or CSH300.

Characteristics

Weight	0.64 kg (1.41 lb)
Assembly	Mounted on symmetrical DIN rail
Amplitude accuracy	±1%
Phase accuracy	< 2°
Maximum permissible current	20 kA - 1 s (on the primary winding of an MV core balance CT with a ratio of 1/50 that does not saturate)
Operating temperature	-25°C à +70°C (-13°F à +158°F)
Storage temperature	-25°C to +70°C (-13°F to +158°F)

Description and dimensions

- Ⓔ ACE990 input terminal block, for connection of the core balance CT.
- Ⓕ ACE990 output terminal block, for connection of the Sepam residual current.

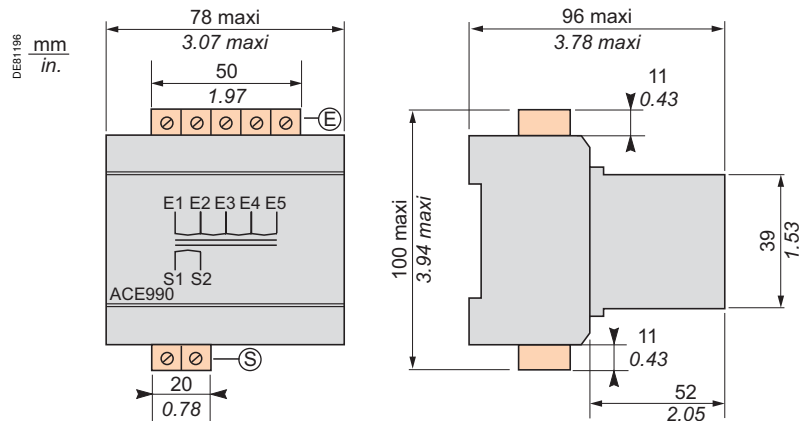

6

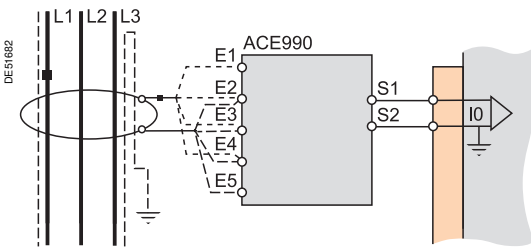

Connection

Connection of core balance CT

Only one core balance CT can be connected to the ACE990 interface. The secondary circuit of the MV core balance CT is connected to 2 of the 5 ACE990 interface input terminals. To define the 2 input terminals, it is necessary to know the following:

- Core balance CT ratio (1/n)
- Core balance CT power
- Close approximation of rated current I_{n0}

(I_{n0} is a general setting in Sepam and defines the earth fault protection setting range between $0.1 I_{n0}$ and $15 I_{n0}$).

The table below can be used to determine:

- The 2 ACE990 input terminals to be connected to the MV core balance CT secondary
- The type of residual current sensor to set
- The exact value of the rated residual current I_{n0} setting, given by the following formula: **$I_{n0} = k \times \text{number of core balance CT turns}$** with k the factor defined in the table below.

The core balance CT must be connected to the interface in the right direction for correct operation: the MV core balance CT secondary output terminal S1 must be connected to the terminal with the lowest index (Ex).

Example:

Given a core balance CT with a ratio of 1/400 2 VA, used within a measurement range of 0.5 A to 60 A.

How should it be connected to Sepam via the ACE990?

1. Choose a close approximation of the rated current I_{n0} , i.e. 5 A.
2. Calculate the ratio:
approx. $I_{n0}/\text{number of turns} = 5/400 = 0.0125$.
3. Find the closest value of k in the table opposite to $k = 0.01136$.
4. Check the minimum power required for the core balance CT: 2 VA core balance CT > 0.1 VA ✓ OK.
5. Connect the core balance CT secondary to ACE990 input terminals E2 and E4.
6. Set Sepam up with:
 $I_{n0} = 0.01136 \times 400 = 4.544 \text{ A}$.

(Note: The original image contains some illegible text here, likely a corrupted scan of a formula or diagram.)

This value of I_{n0} can be used to monitor current between 0.45 A and 67.5 A.

Wiring of MV core balance CT secondary circuit.

- MV core balance CT S1 output to ACE990 E2 input terminal
- MV core balance CT S2 output to ACE990 E4 input terminal.

K value	ACE990 input terminals to be connected	Residual current sensor setting	Min. MV core balance CT power
0.00578	E1 - E5	ACE990 - range 1	0.1 VA
0.00676	E2 - E5	ACE990 - range 1	0.1 VA
0.00885	E1 - E4	ACE990 - range 1	0.1 VA
0.00909	E3 - E5	ACE990 - range 1	0.1 VA
0.01136	E2 - E4	ACE990 - range 1	0.1 VA
0.01587	E1 - E3	ACE990 - range 1	0.1 VA
0.01667	E4 - E5	ACE990 - range 1	0.1 VA
0.02000	E3 - E4	ACE990 - range 1	0.1 VA
0.02632	E2 - E3	ACE990 - range 1	0.1 VA
0.04000	E1 - E2	ACE990 - range 1	0.2 VA
0.05780	E1 - E5	ACE990 - range 2	2.5 VA
0.06757	E2 - E5	ACE990 - range 2	2.5 VA
0.08850	E1 - E4	ACE990 - range 2	3.0 VA
0.09091	E3 - E5	ACE990 - range 2	3.0 VA
0.11364	E2 - E4	ACE990 - range 2	3.0 VA
0.15873	E1 - E3	ACE990 - range 2	4.5 VA
0.16667	E4 - E5	ACE990 - range 2	4.5 VA
0.20000	E3 - E4	ACE990 - range 2	5.5 VA
0.26316	E2 - E3	ACE990 - range 2	7.5 VA

Connection to Sepam series 20 and Sepam series 40

To residual current I0 input, on connector (A), terminals 19 and 18 (shielding).

Connection to 9 UqYf[miSepam series 60

To residual current I0 input, on connector (E), terminals 15 and 14 (shielding).

Connection to 9 UqYf[miSepam series 80

- To residual current I0 input, on connector (E), terminals 15 and 14 (shielding)
- To residual current I'0 input, on connector (E), terminals 18 and 17 (shielding).

Recommended cables

- Cable between core balance CT and ACE990: less than 50 m (160 ft) long
- Sheathed cable, shielded by tinned copper braid between the ACE990 and Sepam, maximum length 2 m (6.6 ft)
- Cable cross-section between 0.93 mm² (AWG 18) and 2.5 mm² (AWG 12)
- Resistance per unit length less than 100 mΩ/m (30.5 mΩ/ft)
- Minimum dielectric strength: 100 Vrms.

Connect the connection cable shielding in the shortest manner possible (2 cm or 5.08 in maximum) to the shielding terminal on the Sepam connector. Flatten the connection cable against the metal frames of the cubicle.

The connection cable shielding is grounded in Sepam. Do not ground the cable by any other means.





10 input/4 output MES114 module.

Function

The 4 outputs included on the Sepam series 20 and 40 base unit can be extended by adding an optional MES114 module with 10 inputs and 4 outputs, available in 3 versions:

- MES114: 10 DC inputs, voltage from 24 V DC to 250 V DC
- MES114E: 10 inputs, voltage 110-125 V AC or V DC
- MES114F: 10 inputs, voltage 220-250 V AC or V DC.

Characteristics

MES114 module

Weight	0.28 kg (0.617 lb)
Operating temperature	-25°C to +70°C (-13°F to +158°F)
Environmental characteristics	Same characteristics as Sepam base units

Logic inputs	MES114	MES114E	MES114F		
Voltage	24 to 250 V DC	110 to 125 V DC	110 V AC	220 to 250 V DC	220 to 240 V AC
Range	19.2 to 275 V DC	88 to 150 V DC	88 to 132 V AC	176 to 275 V DC	176 to 264 V AC

Frequency	-	-	47 to 63 Hz	-	47 to 63 Hz	
Typical consumption	3 mA	3 mA	3 mA	3 mA	3 mA	
Typical switching threshold	14 V DC	82 V DC	58 V AC	154 V DC	120 V AC	
Input limit voltage	At state 1	≥ 19 V DC	≥ 88 V DC	≥ 88 V AC	≥ 176 V DC	≥ 176 V AC
	At state 0	≤ 6 V DC	≤ 75 V DC	≤ 22 V AC	≤ 137 V DC	≤ 48 V AC
Isolation of inputs from other isolated groups	Enhanced	Enhanced	Enhanced	Enhanced	Enhanced	

O11 control relay output

Voltage	DC	24/48 V DC	127 V DC	220 V DC	250 V DC	-
	AC (47.5 to 63 Hz)	-	-	-	-	100 to 240 V AC
Continuous current		8 A	8 A	8 A	8 A	8 A
Breaking capacity	Resistive load	8/4 A	0.7 A	0.3 A	0.2 A	8 A
	L/R load < 20 ms	6/2 A	0.5 A	0.2 A	-	-
	L/R load < 40 ms	4/1 A	0.2 A	0.1 A	-	-
	p.f. load > 0.3	-	-	-	-	5 A
Making capacity		< 15 A for 200 ms				
Isolation of outputs from other isolated groups		Enhanced				

Annunciation relay output O12 to O14

Voltage	DC	24/48 V DC	127 V DC	220 V DC	250 V DC	-
	AC (47.5 to 63 Hz)	-	-	-	-	100 to 240 V AC
Continuous current		2 A	2 A	2 A	2 A	2 A
Breaking capacity	Resistive load	2/1 A	0.6 A	0.3 A	0.2 A	-
	L/R load < 20 ms	2/1 A	0.5 A	0.15 A	-	-
	p.f. load > 0.3	-	-	-	-	1 A
	Making capacity		< 15 A for 200 ms			
Isolation of outputs in relation to other isolated groups		Enhanced				

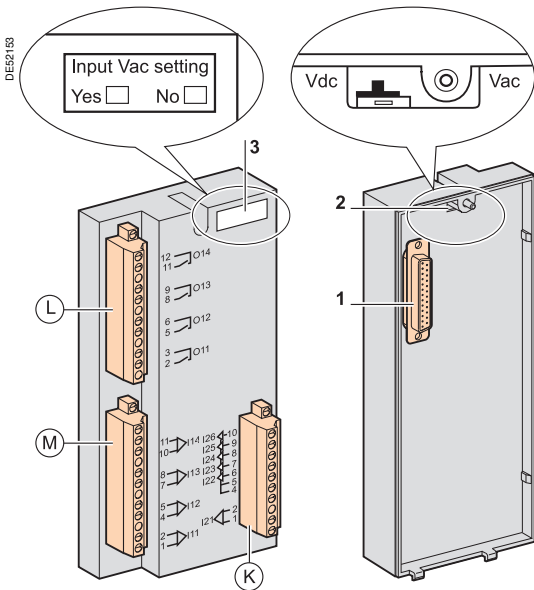

Description

Ⓛ, Ⓜ and Ⓚ: 3 removable, lockable screw-type connectors

Ⓛ: connectors for 4 relay outputs:

- O11: 1 control relay output
- O12 to O14: 3 annunciation relay outputs

Ⓜ: connectors for 4 independent logic inputs I11 to I14

Ⓚ: connectors for 6 logic inputs:

- I21: 1 independent logic input
- I22 to I26: 5 common point logic inputs.

1 25-pin sub-D connector to connect the module to the base unit.

2 Voltage selector switch for MES114E and MES114F module inputs, to be set to:

- V DC for 10 DC voltage inputs (default setting)
- V AC for 10 AC voltage inputs.

3 Label to be filled in to indicate the chosen parameter setting for MES114E and MES114F input voltages.

The parameter setting status can be accessed in the "Sepam Diagnosis" screen of the SFT2841 software tool.

Parameter setting of the inputs for AC voltage (V AC setting) inhibits the "operating time measurement" function.

Assembly

1. Insert the 2 pins on the MES module into the slots 1 on the base unit.
2. Flatten the module up against the base unit to plug it into the connector 2.
3. Tighten the mounting screw 3.



Connection

The inputs are potential-free and the DC power supply source is external.

⚠ ⚠ DANGER

HAZARD OF ELECTRIC SHOCK, ELECTRIC ARC OR BURNS

- Only qualified personnel should install this equipment. Such work should be performed only after reading this entire set of instructions and checking the technical characteristics of the device.
- NEVER work alone.
- Turn off all power supplying this equipment before working on or inside it. Consider all sources of power, including the possibility of backfeeding.
- Always use a properly rated voltage sensing device to confirm that all power is off.
- Screw tight all terminals, even those not in use.

Failure to follow these instructions will result in death or serious injury.

Wiring of connectors (L), (M) and (K):

- Wiring with no fittings:
 - 1 wire with maximum cross-section 0.2 to 2.5 mm² (AWG 24-12)
 - or 2 wires with maximum cross-section 0.2 to 1 mm² (AWG 24-18)
 - stripped length: 8 to 10 mm (0.315 to 0.39 in)
- Wiring with fittings:
 - terminal 5, recommended wiring with Telemecanique fitting:
 - DZ5CE015D for 1 wire 1.5 mm² (AWG 16)
 - DZ5CE025D for 1 wire 2.5 mm² (AWG 12)
 - AZ5DE010D for 2 wires 1 mm² (AWG 18)
 - tube length: 8.2 mm (0.32 in)
 - stripped length: 8 mm (0.31 in).

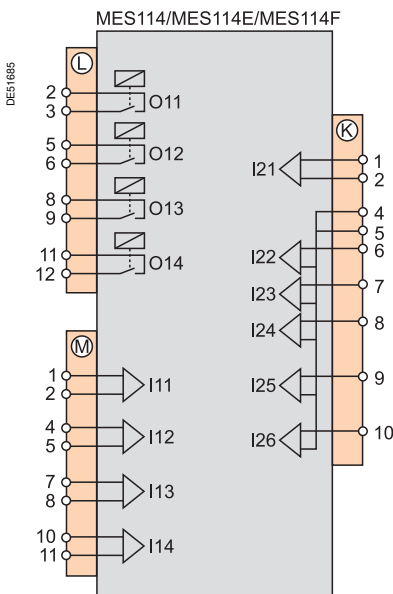

Optional remote modules Connection





The optional MET148-2, MSA141 or DSM303 modules are connected to the base unit connector (D) by a series of links using prefabricated cords which come in 3 different lengths with black fittings.

- CCA770 (L = 0.6 m or 2 ft)
- CCA772 (L = 2 m or 6.6 ft)
- CCA774 (L = 4 m or 13.1 ft).

The DSM303 module may only be connected at the end of the series.

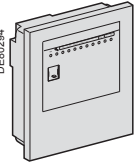
Maximum configuration

A maximum of three modules may be connected to the base unit, in compliance with the module order and maximum connection lengths indicated in the table:

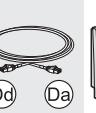
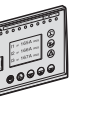
Base	Cord	Module 1	Cord	Module 2	Cord	Module 3
						
	CCA772	MSA141	CCA770	MET148-2	CCA774	DSM303
	CCA772	MSA141	CCA770	MET148-2	CCA772	MET148-2
	CCA772	MET148-2	CCA770	MET148-2	CCA774	DSM303

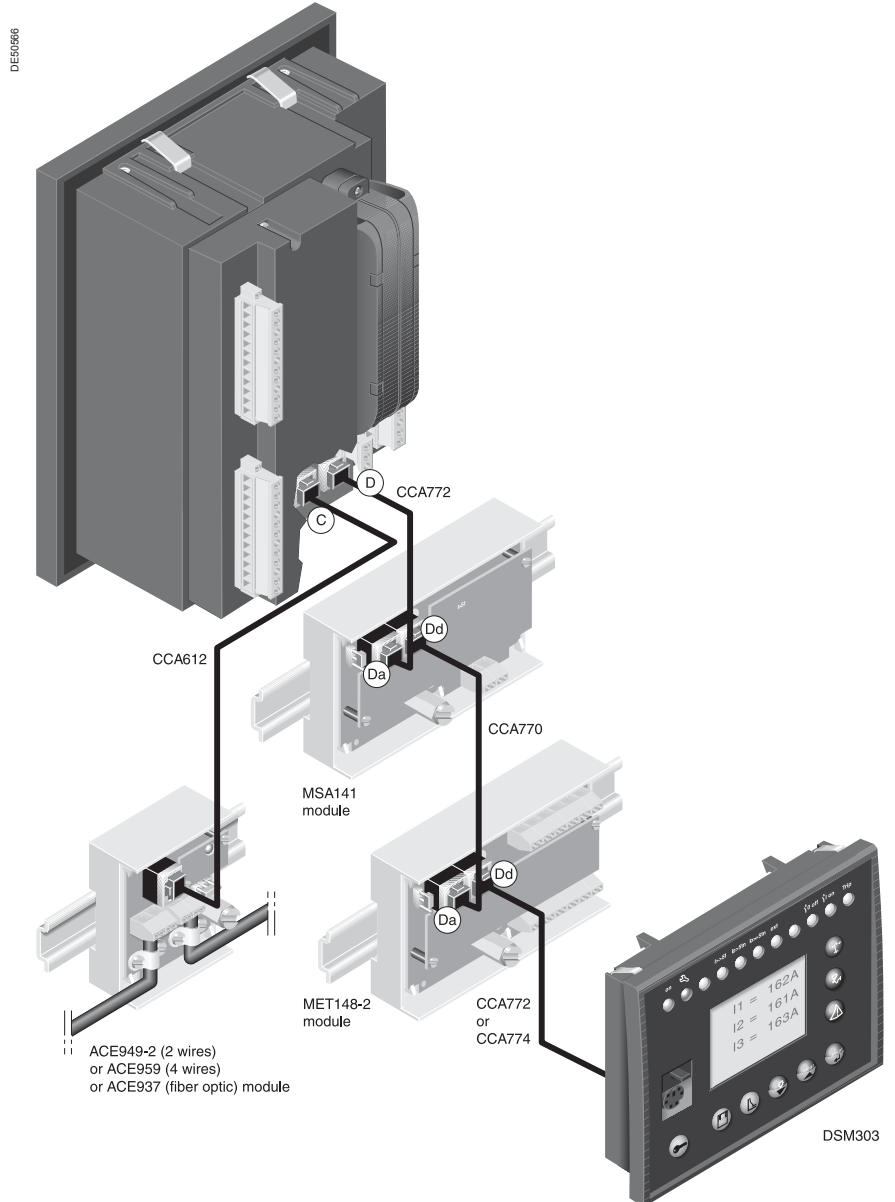

DE50966

MET148-2 Temperature sensor module

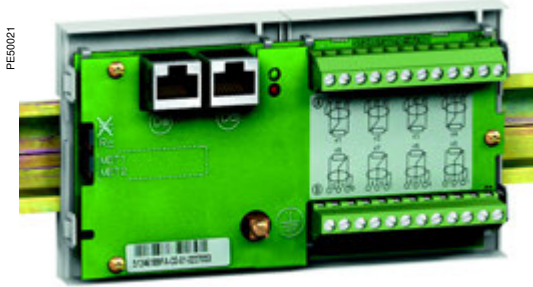

Function

The MET148-2 module can be used to connect 8 temperature sensors (RTDs) of the same type:

- Pt100, Ni100 or Ni120 type RTDs, according to parameter setting
- 3-wire temperature sensors
- A single module for each Sepam series 20 base unit, to be connected by one of the CCA770 (0.6 or 2 ft), CCA772 (2 m or 6.6 ft) or CCA774 (4 m or 13.1 ft) cords
- 2 modules for each Sepam series 40, Sepam series 60 or series 80 base unit, to be connected by CCA770 (0.6 or 2 ft), CCA772 (2 m or 6.6 ft) or CCA774 (4 m or 13.1 ft) cords

The temperature measurement (e.g. in a transformer or motor winding) is utilized by the following protection functions:

- Thermal overload (to take ambient temperature into account)
- Temperature monitoring.

Characteristics

MET148-2 module		
Weight	0.2 kg (0.441 lb)	
Assembly	On symmetrical DIN rail	
Operating temperature	-25°C to +70°C (-13°F to +158°F)	
Environmental characteristics	Same characteristics as Sepam base units	
Temperature sensors	Pt100	Ni100/Ni120
Isolation from earth	None	None
Current injected in RTD	4 mA	4 mA

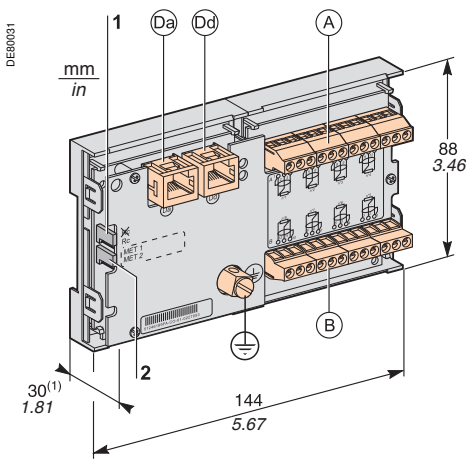

(1) 70 mm (2.8 in) with CCA77x cord connected.

Description and dimensions

- (A) Terminal block for RTDs 1 to 4
- (B) Terminal block for RTDs 5 to 8
- (Da) RJ45 connector to connect the module to the base unit with a CCA77x cord
- (Dd) RJ45 connector to link up the next remote module with a CCA77x cord (according to application)
- (⊥) Grounding/earthing terminal

- 1 Jumper for impedance matching with load resistor (Rc), to be set to:
 - Rc, if the module is not the last interlinked module (default position)
 - Rc, if the module is the last interlinked module.
- 2 Jumper used to select module number, to be set to:
 - MET1: 1st MET148-2 module, to measure temperatures T1 to T8 (default position)
 - MET2: 2nd MET148-2 module, to measure temperatures T9 to T16 (for Sepam series 40, Sepam series 60 and series 80 only).

6

Connection

⚠ ⚠ DANGER

HAZARD OF ELECTRIC SHOCK, ELECTRIC ARC OR BURNS

- Only qualified personnel should install this equipment. Such work should be performed only after reading this entire set of instructions and checking the technical characteristics of the device.
- NEVER work alone.
- Check that the temperature sensors are isolated from dangerous voltages.

Failure to follow these instructions will result in death or serious injury.

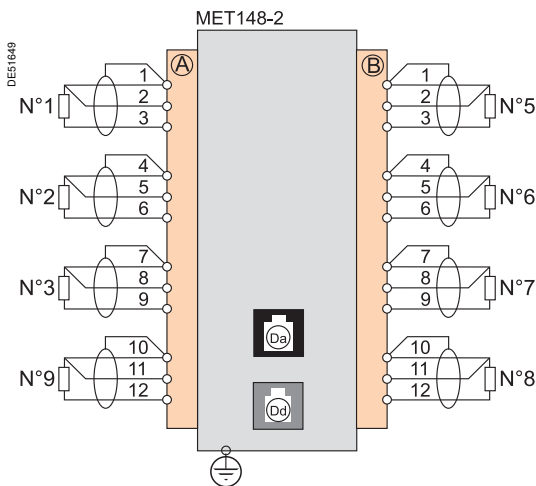

Connection of the earthing terminal

By tinned copper braid with cross-section $\geq 6 \text{ mm}^2$ (AWG 10) or cable with cross-section $\geq 2.5 \text{ mm}^2$ (AWG 12) and length $\leq 200 \text{ mm}$ (7.9 in), fitted with a 4 mm (0.16 in) ring lug.

Check the tightness (maximum tightening torque 2.2 Nm or 19.5 lb-in).

Connection of RTDs to screw-type connectors

- 1 wire with cross-section 0.2 to 2.5 mm² (AWG 24-12)
- or 2 wires with cross-section 0.2 to 1 mm² (AWG 24-18)

Recommended cross-sections according to distance:

- Up to 100 m (330 ft) $\geq 1 \text{ mm}^2$ (AWG 18)
- Up to 300 m (990 ft) $\geq 1.5 \text{ mm}^2$ (AWG 16)
- Up to 1 km (0.62 mi) $\geq 2.5 \text{ mm}^2$ (AWG 12)

Maximum distance between sensor and module: 1 km (0.62 mi)

Wiring precautions

- It is preferable to use shielded cables

The use of unshielded cables can cause measurement errors which vary in degree according to the level of surrounding electromagnetic disturbance

- Only connect the shielding at the MET148-2 end, in the shortest manner possible, to the corresponding terminals of connectors (A) and (B)
- Do not connect the shielding at the RTD end.

Accuracy derating according to wiring

The error Δt is proportional to the length of the cable and inversely proportional to the cable cross-section:

$$\Delta t(^{\circ}\text{C}) = 2 \times \frac{L(\text{km})}{S(\text{mm}^2)}$$

- $\pm 2.1^{\circ}\text{C}/\text{km}$ for 0.93 mm² cross-section (AWG 18)
- $\pm 1^{\circ}\text{C}/\text{km}$ for 1.92 mm² cross-section (AWG 14).



MSA141 analog output module.

Function

The MSA141 module converts one of the Sepam measurements into an analog signal:

- Selection of the measurement to be converted by parameter setting
- 0-1 mA, 0-10 mA, 4-20 mA, 0-20 mA analog signal according to parameter setting
- Scaling of the analog signal by setting minimum and maximum values of the converted measurement.

Example: the setting used to have phase current 1 as a 0-10 mA analog output with a dynamic range of 0 to 300 A is:

- minimum value = 0
- maximum value = 3000
- A single module for each Sepam base unit, to be connected by one of the CCA770 (0.6m or 2 ft), CCA772 (2m or 6.6 ft) or CCA774 (4m or 13.1 ft) cords.

The analog output can also be remotely managed via the communication network.

Characteristics

MSA141 module				
Weight	0.2 kg (0.441 lb)			
Assembly	On symmetrical DIN rail			
Operating temperature	-25°C to +70°C (-13°F to +158°F)			
Environmental characteristics	Same characteristics as Sepam base units			
Analog output				
Current	4 -20 mA, 0-20 mA, 0-10 mA, 0-1 mA			
Scaling (no data input checking)	Minimum value			
	Maximum value			
Load impedance	< 600 Ω (including wiring)			
Accuracy	0.5% full scale or 0,01 mA			
Measurements available	Unit	Series 20	Series 40	Series 60/ Series 80
Phase and residual currents	0.1 A	■	■	■
Phase-to-neutral and phase-to-phase voltages	1 V	■	■	■
Frequency	0.01 Hz	■	■	■
Thermal capacity used	1%	■	■	■
Temperatures	1°C (1°F)	■	■	■
Active power	0.1 kW		■	■
Reactive power	0.1 kvar		■	■
Apparent power	0.1 kVA		■	■
Power factor	0.01			■
Remote setting via communication link		■	■	■

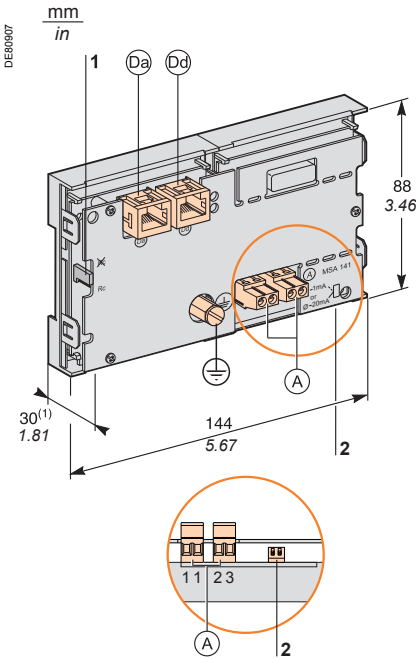

(1) 70 mm (2.8 in) with CCA77x cord connected.

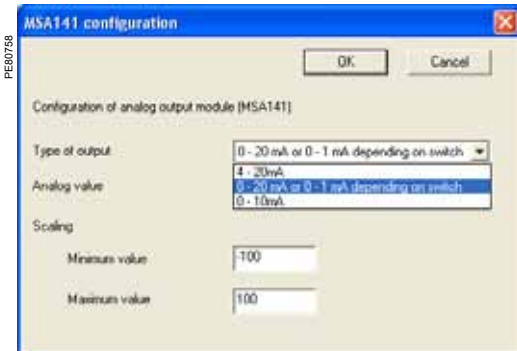

Analog output module (MSA141) setting window.

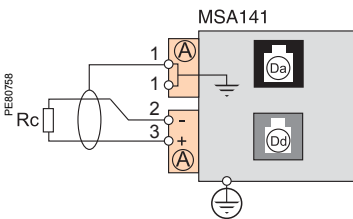

Description and dimensions

- (A) Terminal block for analog output
- (Da) RJ45 socket to connect the module to the base unit with a CCA77x cord
- (Dd) RJ45 socket to link up the next remote module with a CCA77x cord (according to application)
- (⊕) Earthing terminal

- 1 Jumper for impedance matching with load resistor (Rc), to be set to:
 - Rc, if the module is not the last interlinked module (default position)
 - Rc, if the module is the last interlinked module.

- 2 Micro-switches to set the analog output type:

Micro-switches	Position	Output type
	low (default position)	0-20 mA
		4-20 mA
		0-10 mA
	high	0-1 mA

Output Setting

The analog output type is configured in 2 steps:

1. Hardware setting: set the 2 micro-switches:
 - on low position for a 0-20 mA, 4-20 mA or 0-10 mA output type
 - on high position for a 0-1 mA output type.
2. Software configuration: select the desired output type in the SFT2841 setting software **Analog output module (MSA141) setting** window and validate by pressing the **OK** button.

Note : The 0-1 mA output works only if the 0-20 mA or 0-1 mA depending on switch output type has been set in the SFT2841 setting software (step 2).

Connection

Connection of the earthing terminal

By tinned copper braid with cross-section $\geq 6 \text{ mm}^2$ (AWG 10) or cable with cross-section $\geq 2.5 \text{ mm}^2$ (AWG 12) and length $\leq 200 \text{ mm}$ (7.9 in), equipped with a 4 mm (0.16 in) ring lug. Check the tightness (maximum tightening torque 2.2 Nm or 19.5 lb-in).

Connection of analog output to screw-type connector

- 1 wire with cross-section 0.2 to 2.5 mm² (AWG 24-12)
- or 2 wires with cross-section 0.2 to 1 mm² (AWG 24-18).

Wiring precautions

- It is preferable to use shielded cables
- Use tinned copper braid to connect the shielding at least at the MSA141 end.

DSM303 Remote advanced UMI module



DSM303 remote advanced UMI module.

Function

When associated with a Sepam that does not have its own advanced user-machine interface, the DSM303 offers all the functions available on a Sepam integrated advanced UMI.

It can be installed on the front panel of the cubicle in the most suitable operating location:

- Reduced depth < 30 mm (1.2 in)
- A single module for each Sepam, to be connected by one of the CCA772 (2 m or 6.6 ft) or CCA774 (4 m or 13.1 ft) cords.

The module cannot be connected to Sepam units with integrated advanced UMIs.

Characteristics

DSM303 module

Weight	0.3 kg (0.661 lb)
Assembly	Flush-mounted
Operating temperature	-25°C to +70°C (-13°F to +158°F)
Environmental characteristics	Same characteristics as Sepam base units

DSM303 Remote advanced UMI module

Description and dimensions

The module is simply flush-mounted and secured by its clips. No additional screw-type fastening is required.

Front view

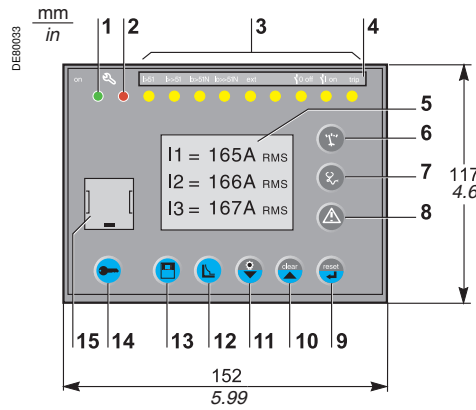

Side view

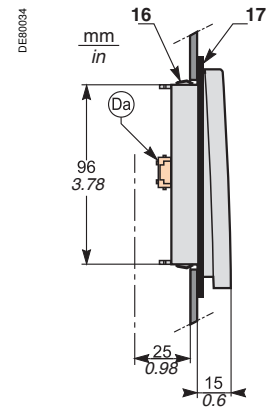

- 1 Green LED: Sepam on
- 2 Red LED:
 - steadily on: module unavailable
 - flashing: Sepam link unavailable
- 3 9 yellow LEDs
- 4 Label identifying the LEDs
- 5 Graphic LCD screen
- 6 Display of measurements
- 7 Display of switchgear, network and machine diagnosis data
- 8 Display of alarm messages
- 9 Sepam reset (or confirm data entry)
- 10 Alarm acknowledgment and clearing (or move cursor up)
- 11 LED test (or move cursor down)
- 12 Access to protection settings
- 13 Access to Sepam parameters
- 14 Entry of 2 passwords
- 15 PC connection port
- 16 Mounting clip
- 17 Gasket to ensure NEMA 12 tightness
(gasket supplied with the DSM303 module, to be installed if necessary)

(Da) RJ45 lateral output connector to connect the module to the base unit with a CCA77x cord.

CAUTION

HAZARD OF CUTS

Trim the edges of the cut-out plates to remove any jagged edges.

Failure to follow these instructions can result in injury.

Cut-out for flush-mounting (mounting plate thickness < 3 mm or 0.12 in)

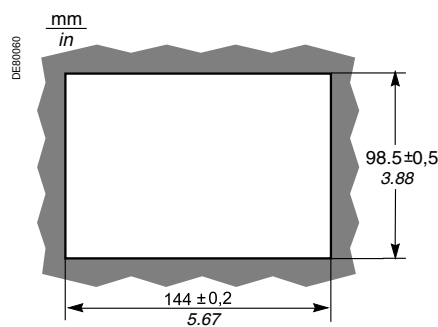

Connection

(Da) RJ45 socket to connector the module to the base unit with a CCA77x cord. The DSM303 module is always the last interlinked remote module and it systematically ensures impedance matching by load resistor (Rc).

DSM303

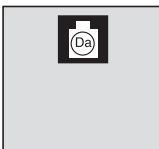

MT10151

Connection of communication interfaces

Connection cords

CCA612 connection cord

Function

The CCA612 prefabricated cord is used to connect ACE949-2, ACE959, ACE937, ACE969TP-2 and ACE969FO-2 communication interfaces:

- To the white communication port (C) on a Sepam series 20 or series 40 base unit
- To the white communication port (C1) on an Easergy Sepam series 60 base unit.
- To the white communication ports (C1) or (C2) on an Easergy Sepam series 80 base unit.

Characteristics

- Length = 3 m (9.8 ft)
- Fitted with 2 white RJ45 connectors.

Sepam series 20 and Sepam series 40

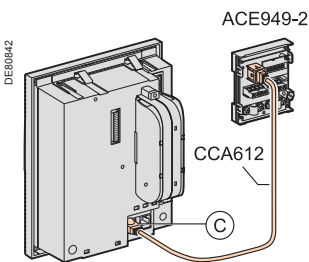

Easergy Sepam series 60

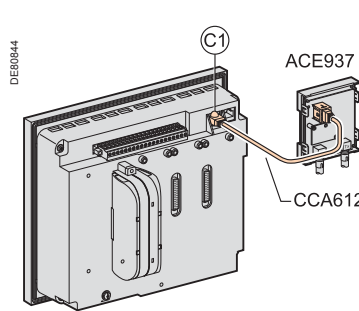

Easergy Sepam series 80

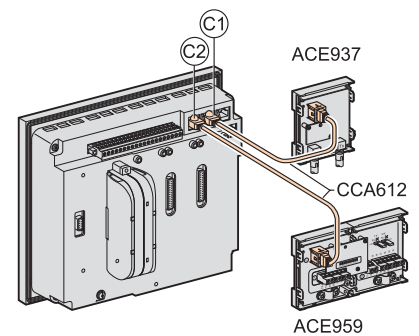

NOTICE

HAZARD OF DEFECTIVE COMMUNICATION

- Never use the (C2) and (F) communication ports on an Easergy Sepam series 80 simultaneously.
- The only communication ports on an Easergy Sepam series 80 unit that can be used simultaneously are ports (C1) and (C2) or ports (C1) and (F).

Failure to follow these instructions can result in equipment damage.

CCA614 connection cord

Function

The CCA614 prefabricated cord is used to connect ACE850TP and ACE850FO communication interfaces:

- To the white communication port (C) on a Sepam series 40 base unit
- To the blue communication port (F) on an Easergy Sepam series 60 or Sepam series 80 base unit.

Characteristics

- Length = 3 m (9.8 ft)
- Fitted with 2 blue RJ45 connectors
- Minimum curvature radius = 50 mm (1.97 in)

Sepam series 40

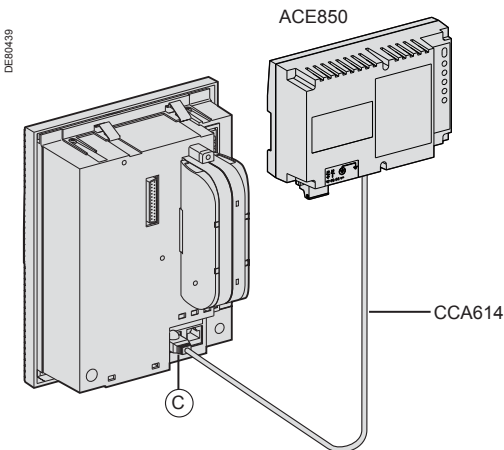

Easergy Sepam series 60 and Easergy Sepam series 80

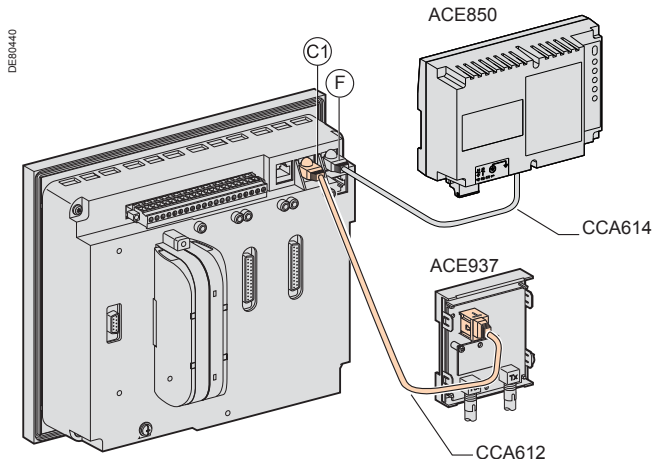

Connection of communication interfaces

Characteristics of communication networks

RS 485 network for ACE949-2, ACE959 and ACE969TP-2 interfaces

RS 485 network cable	2-wire	4-wire
RS 485 medium	1 shielded twisted pair	2 shielded twisted pairs
Distributed power supply	1 shielded twisted pair	1 shielded twisted pair
Shielding	Tinned copper braid, coverage > 65%	
Characteristic impedance	120 Ω	
Gauge	AWG 24	
Resistance per unit length	< 100 Ω/km (62.1 Ω/mi)	
Capacitance between conductors	< 60 pF/m (18.3 pF/ft)	
Capacitance between conductor and shielding	< 100 pF/m (30.5 pF/ft)	
Maximum length	1300 m (4270 ft)	

Fiber-optic network for ACE937 and ACE969FO-2 interfaces

Fiber-optic communication port				
Fiber type		Graded-index multimode silica		
Wavelength		820 nm (invisible infra-red)		
Type of connector		ST (BFOC bayonet fiber optic connector)		
Fiber optic diameter (μm)	Numerical aperture (NA)	Maximum attenuation (dBm/km)	Minimum optical power available (dBm)	Maximum fiber length
50/125	0.2	2.7	5.6	700 m (2300 ft)
62.5/125	0.275	3.2	9.4	1800 m (5900 ft)
100/140	0.3	4	14.9	2800 m (9200 ft)
200 (HCS)	0.37	6	19.2	2600 m (8500 ft)

Fiber-optic Ethernet network for the ACE850FO communication interface

Fiber-optic communication port					
Fiber type		Multimode			
Wavelength		1300 nm			
Type of connector		SC			
Fiber optic diameter (μm)	TX minimum optical power (dBm)	TX maximum optical power (dBm)	RX sensitivity (dBm)	RX saturation (dBm)	Maximum distance
50/125	-22.5	-14	-33.9	-14	2 km (1.24 mi)
62.5/125	-19	-14	-33.9	-14	2 km (1.24 mi)

Wired Ethernet network for the ACE850TP communication interface

Wired communication port			
Connector type	Data	Medium	Maximum distance
RJ45	10/100 Mbps	Cat 5 STP or FTP or SFTP	100 m (328 ft)

ACE949-2 2-wire RS 485 network interface



ACE949-2 2-wire RS 485 network connection interface.

Function

The ACE949-2 interface performs 2 functions:

- Electrical interface between Sepam and a 2-wire RS 485 communication network
- Main network cable branching box for the connection of a Sepam with a CCA612 cord.

Characteristics

ACE949-2 module

Weight	0.1 kg (0.22 lb)
Assembly	On symmetrical DIN rail
Operating temperature	-25°C to +70°C (-13°F to +158°F)
Environmental characteristics	Same characteristics as Sepam base units

2-wire RS 485 electrical interface

Standard	EIA 2-wire RS 485 differential
Distributed power supply	External, 12 V DC or 24 V DC ±10%
Power consumption	16 mA in receiving mode 40 mA maximum in sending mode

Maximum length of 2-wire RS 485 network with standard cable

Number of Sepam units	Maximum length with 12 V DC power supply	Maximum length with 24 V DC power supply
5	320 m (1000 ft)	1000 m (3300 ft)
10	180 m (590 ft)	750 m (2500 ft)
20	160 m (520 ft)	450 m (1500 ft)
25	125 m (410 ft)	375 m (1200 ft)

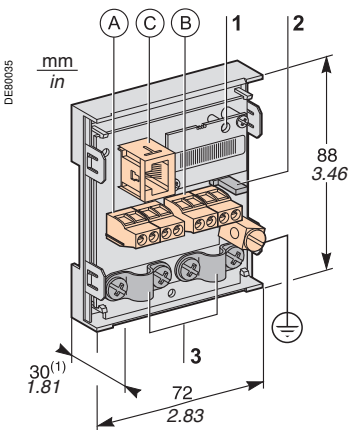

(1) 70 mm (2.8 in) with CCA612 cord connected.

Description and dimensions

- (A) and (B) Terminal blocks for network cable
- (C) RJ45 socket to connect the interface to the base unit with a CCA612 cord
- (t) Grounding/earthing terminal

- 1 Link activity LED, flashes when communication is active (sending or receiving in progress).
- 2 Jumper for RS 485 network line-end impedance matching with load resistor ($R_c = 150 \Omega$), to be set to:
 - \times , if the module is not at one end of the network (default position)
 - R_c , if the module is at one end of the network.
- 3 Network cable clamps (inner diameter of clamp = 6 mm or 0.24 in).

Connection

- Connection of network cable to screw-type terminal blocks (A) and (B)
- Connection of the earthing terminal by tinned copper braid with cross-section $\geq 6 \text{ mm}^2$ (AWG 10) or cable with cross-section $\geq 2.5 \text{ mm}^2$ (AWG 12) and length $\leq 200 \text{ mm}$ (7.9 in), fitted with a 4 mm (0.16 in) ring lug. Check the tightness (maximum tightening torque 2.2 Nm or 19.5 lb-in).
- The interfaces are fitted with clamps to hold the network cable and recover shielding at the incoming and outgoing points of the network cable:
 - the network cable must be stripped
 - the cable shielding braid must be around and in contact with the clamp
- The interface is to be connected to connector (C) on the base unit using a CCA612 cord (length = 3 m or 9.8 ft, white fittings)
- The interfaces are to be supplied with 12 V DC or 24 V DC.

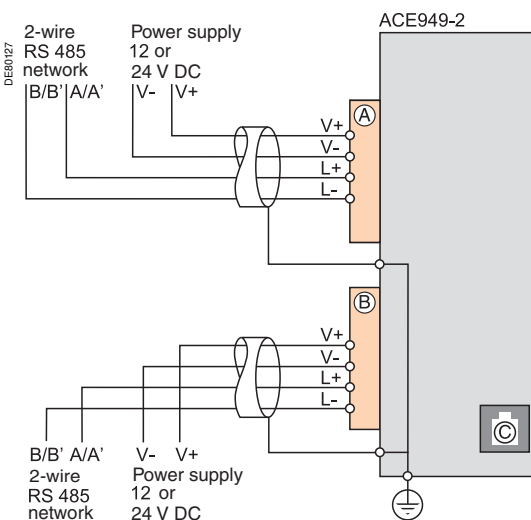

ACE959 4-wire RS 485 network interface



ACE959 4-wire RS 485 network connection interface.

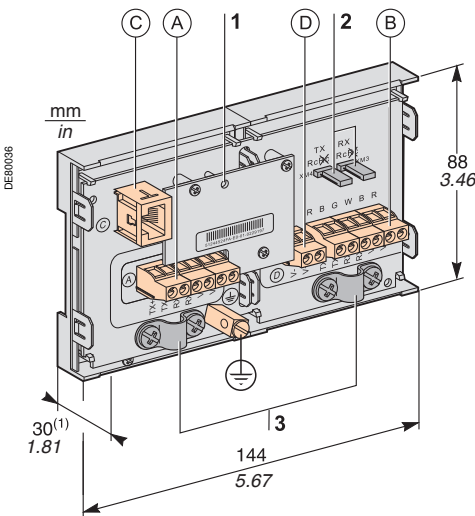

(1) 70 mm (2.8 in) with CCA612 cord connected.

Function

The ACE959 interface performs 2 functions:

- Electrical interface between Sepam and a 4-wire RS 485 communication network
- Main network cable branching box for the connection of a Sepam with a CCA612 cord.

Characteristics

ACE959 module

Weight	0.2 kg (0.441 lb)
Assembly	On symmetrical DIN rail
Operating temperature	-25°C to +70°C (-13°F to +158°F)
Environmental characteristics	Same characteristics as Sepam base units

4-wire RS 485 electrical interface

Standard	EIA 4-wire RS 485 differential
Distributed power supply	External, 12 V DC or 24 V DC ±10%
Power consumption	16 mA in receiving mode 40 mA maximum in sending mode

Maximum length of 4-wire RS 485 network with standard cable

Number of Sepam units	Maximum length with 12 V DC power supply	Maximum length with 24 V DC power supply
5	320 m (1000 ft)	1000 m (3300 ft)
10	180 m (590 ft)	750 m (2500 ft)
20	160 m (520 ft)	450 m (1500 ft)
25	125 m (410 ft)	375 m (1200 ft)

Description and dimensions

- (A) and (B) Terminal blocks for network cable
- (C) RJ45 socket to connect the interface to the base unit with a CCA612 cord
- (D) Terminal block for a separate auxiliary power supply (12 V DC or 24 V DC)
- (t) Grounding/earthing terminal

- 1 Link activity LED, flashes when communication is active (sending or receiving in progress).
- 2 Jumper for 4-wire RS 485 network line-end impedance matching with load resistor ($R_c = 150 \Omega$), to be set to:
 - R_c , if the module is not at one end of the network (default position)
 - R_c , if the module is at one end of the network.
- 3 Network cable clamps (inner diameter of clamp = 6 mm or 0.24 in).

Connection

- Connection of network cable to screw-type terminal blocks (A) and (B)
- Connection of the earthing terminal by tinned copper braid with cross-section $\geq 6 \text{ mm}^2$ (AWG 10) or cable with cross-section $\geq 2.5 \text{ mm}^2$ (AWG 12) and length $\leq 200 \text{ mm}$ (7.9 in), fitted with a 4 mm (0.16 in) ring lug. Check the tightness (maximum tightening torque 2.2 Nm or 19.5 lb-in).
- The interfaces are fitted with clamps to hold the network cable and recover shielding at the incoming and outgoing points of the network cable:
 - the network cable must be stripped
 - the cable shielding braid must be around and in contact with the clamp
- The interface is to be connected to connector (C) on the base unit using a CCA612 cord (length = 3 m or 9.8 ft, white fittings)
- The interfaces are to be supplied with 12 V DC or 24 V DC
- The ACE959 can be connected to a separate distributed power supply (not included in shielded cable). Terminal block (D) is used to connect the distributed power supply module.

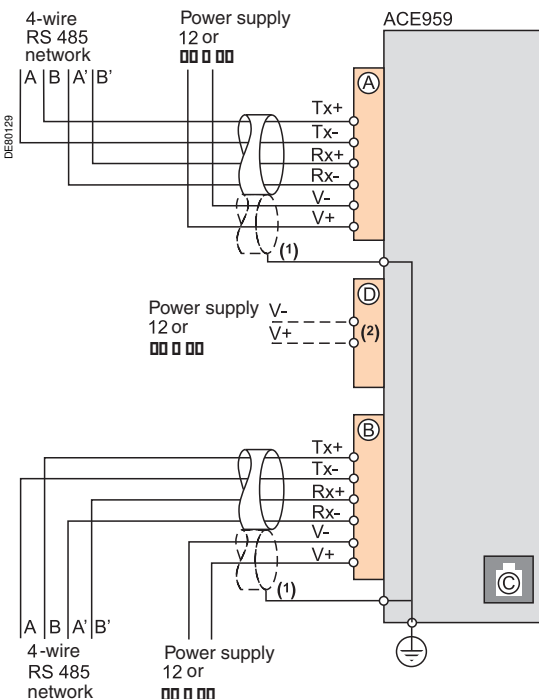

- (1) Distributed power supply with separate wiring or included in the shielded cable (3 pairs).
 (2) Terminal block for connection of the distributed power supply module.



ACE937 fiber optic connection interface.

CAUTION
HAZARD OF BLINDING
 Never look directly into the end of the fiber optic.
 Failure to follow these instructions can result in serious injury.

Function

The ACE937 interface is used to connect Sepam to a fiber optic communication star system.
 This remote module is connected to the Sepam base unit by a CCA612 cord.

Characteristics

ACE937 module				
Weight	0.1 kg (0.22 lb)			
Assembly	On symmetrical DIN rail			
Power supply	Supplied by Sepam			
Operating temperature	-25°C to +70°C (-13°F to +158°F)			
Environmental characteristics	Same characteristics as Sepam base units			
Fiber optic interface				
Fiber type	Graded-index multimode silica			
Wavelength	820 nm (invisible infra-red)			
Type of connector	ST (BFOC bayonet fiber optic connector)			
Fiber optic diameter (µm)	Numerical aperture (NA)	Maximum attenuation (dBm/km)	Minimum optical power available (dBm)	Maximum fiber length
50/125	0.2	2.7	5.6	700 m (2300 ft)
62.5/125	0.275	3.2	9.4	1800 m (5900 ft)
100/140	0.3	4	14.9	2800 m (9200 ft)
200 (HCS)	0.37	6	19.2	2600 m (8500 ft)

Maximum length calculated with:
 ■ Minimum optical power available
 ■ Maximum fiber attenuation
 ■ Losses in 2 ST connectors: 0.6 dBm
 ■ Optical power margin: 3 dBm (according to IEC 60870 standard).

Example for a 62.5/125 µm fiber
 $L_{max} = (9.4 - 3 - 0.6) / 3.2 = 1.8 \text{ km (1.12 mi)}$

Description and dimensions

Ⓒ RJ45 socket to connect the interface to the base unit with a CCA612 cord.

- 1 Link activity LED, flashes when communication is active (sending or receiving in progress).
- 2 Rx, female ST type connector (Sepam receiving).
- 3 Tx, female ST type connector (Sepam sending).

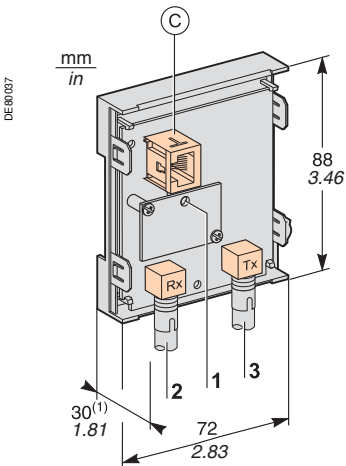

(1) 70 mm (2.8 in) with CCA612 cord connected.

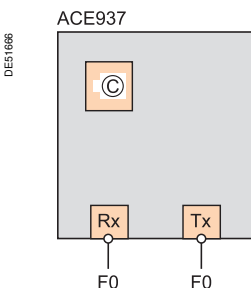

Connection

- The sending and receiving fiber optic fibers must be equipped with male ST type connectors
- Fiber optics screw-locked to Rx and Tx connectors.

The interface is to be connected to connector Ⓒ on the base unit using a CCA612 cord (length = 3 m or 9.8 ft, white fittings).

ACE969TP-2 and ACE969FO-2 Multi-protocol interfaces

PB103454



ACE969TP-2 communication interface.

PB103453

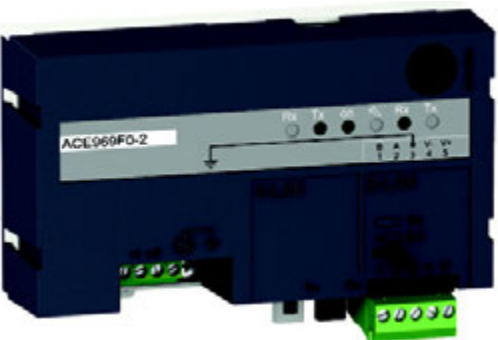

ACE969FO-2 communication interface.

Function

The ACE969 multi-protocol communication interfaces are for Sepam series 20, Sepam series 40, Sepam series 60 and Sepam series 80. They have two communication ports to connect a Sepam to two independent communication networks:

- The S-LAN (Supervisory Local Area Network) port is used to connect Sepam to a communication network dedicated to supervision, using one of the three following protocols:
 - IEC 60870-5-103
 - DNP3
 - Modbus RTU.

The communication protocol is selected at the time of Sepam parameter setting.

- The E-LAN (Engineering Local Area Network) port, reserved for Sepam remote parameter setting and operation using the SFT2841 software.

There are two versions of the ACE969 interfaces, which are identical except for the S-LAN port:

- ACE969TP-2 (Twisted Pair), for connection to an S-LAN network using a 2-wire RS 485 serial link
- ACE969FO-2 (Fiber Optic), for connection to an S-LAN network using a fiber-optic connection (star or ring).

The E-LAN port is always a 2-wire RS 485 type port.

Compatible Sepam

The ACE969TP-2 and ACE969FO-2 multi-protocol interfaces are compatible with the following Sepam:

- Sepam series 20 version \geq V0526
- Sepam series 40 version \geq V3.00
- Sepam series 60 all versions
- Sepam series 80 base version and application version \geq V3.00.

ACE969TP-2 and ACE969FO-2 Multi-protocol interfaces

Characteristics

ACE969TP-2 and ACE969FO-2 module

Technical characteristics

Weight	0.285 kg (0.628 lb)	
Assembly	On symmetrical DIN rail	
Operating temperature	-25°C to +70°C (-13°F to +158°F)	
Environmental characteristics	Same characteristics as Sepam base units	

Power supply

Voltage	24 to 250 V DC	110 to 240 V AC
Range	-20%/+10%	-20%/+10%
Maximum consumption	2 W	3 VA
Inrush current	< 10 A 100 μs	
Acceptable ripple content	12%	
Acceptable momentary outages	20 ms	

2-wire RS 485 communication ports

Electrical interface

Standard	EIA 2-wire RS 485 differential
Distributed power supply	ACE969-2 not required (built-in)

Fiber optic communication port

Fiber optic interface

Fiber type	Graded-index multimode silica
Wavelength	820 nm (invisible infra-red)
Type of connector	ST (BFOC bayonet fiber optic connector)

Maximum length of fiber optic network

Fiber diameter (μm)	Numerical aperture (NA)	Attenuation (dBm/km)	Minimum optical power available (dBm)	Maximum fiber length
50/125	0.2	2.7	5.6	700 m (2300 ft)
62.5/125	0.275	3.2	9.4	1800 m (5900 ft)
100/140	0.3	4	14.9	2800 m (9200 ft)
200 (HCS)	0.37	6	19.2	2600 m (8500 ft)

Maximum length calculated with:

- Minimum optical power available
- Maximum fiber attenuation
- Losses in 2 ST connectors: 0.6 dBm
- Optical power margin: 3 dBm (according to IEC 60870 standard).

Example for a 62.5/125 μm fiber

$$L_{max} = (9.4 - 3 - 0.6) / 3.2 = 1.8 \text{ km (1.12 mi).}$$

Dimensions

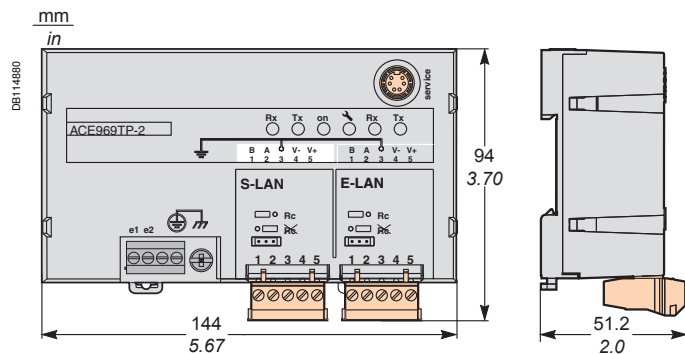

ACE969TP-2 and ACE969FO-2 Multi-protocol interfaces Description

ACE969-2 communication interfaces

ACE969TP-2

ACE969FO-2

- 1 Grounding/earthing terminal using supplied braid
- 2 Power-supply terminal block
- 3 RJ45 socket to connect the interface to the base unit with a CCA612 cord
- 4 Green LED: ACE969-2 energized
- 5 Red LED: ACE969-2 interface status
 - LED off = ACE969-2 set up and communication operational
 - LED flashing = ACE969-2 not set up or setup incorrect
 - LED remains on = ACE969-2 has faulted
- 6 Service connector: reserved for software upgrades
- 7 E-LAN 2-wire RS 485 communication port (ACE969TP-2 and ACE969FO-2)
- 8 S-LAN 2-wire RS 485 communication port (ACE969TP-2)
- 9 S-LAN fiber-optic communication port (ACE969FO-2).

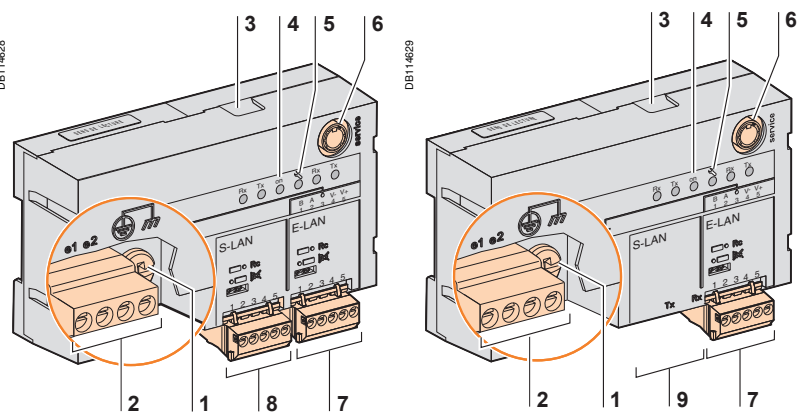

2-wire RS 485 communication ports

S-LAN port (ACE969TP-2)

E-LAN port (ACE969TP-2 or ACE969FO-2)

- 1 Draw-out terminal block, with two rows of connections to the RS 485 2-wire network:
 - 2 black terminals: connection of RS 485 twisted-pair (2 wires)
 - 2 green terminals: connection of twisted pair for distributed power supply
- 2 Indication LEDs:
 - flashing Tx LED: Sepam sending
 - flashing Rx LED: Sepam receiving
- 3 Jumper for RS 485 network line-end impedance matching with load resistor ($R_c = 150 \Omega$), to be set to:
 - R_c , if the interface is not at the line end (default position)
 - $\overline{R_c}$, if the interface is at the line end.

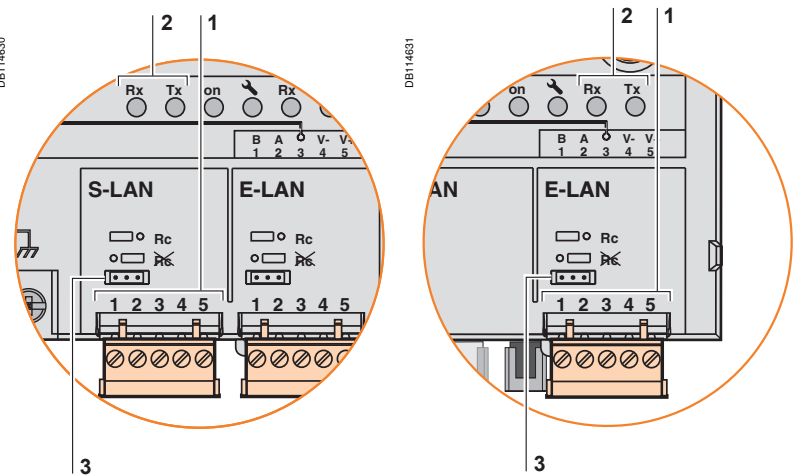

Fiber optic communication port

S-LAN port (ACE969FO-2)

- 1 Indication LEDs:
 - flashing Tx LED: Sepam sending
 - flashing Rx LED: Sepam receiving
- 2 Rx, female ST-type connector (Sepam receiving)
- 3 Tx, female ST-type connector (Sepam sending).

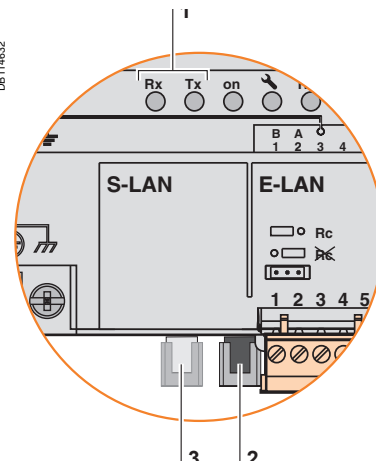

ACE969TP-2 and ACE969FO-2 Multi-protocol interfaces Connection

Power supply and Sepam

- The ACE969-2 interface connects to connector C on the Sepam base unit using a CCA612 cord (length = 3 m or 9.84 ft, white RJ45 fittings)
- The ACE969-2 interface must be supplied with 24 to 250 V DC or 110 to 240 V AC.

⚡ ⚠ DANGER

HAZARD OF ELECTRIC SHOCK, ELECTRIC ARC OR BURNS

- Only qualified personnel should install this equipment. Such work should be performed only after reading this entire set of instructions and checking the technical characteristics of the device.
- NEVER work alone.
- Turn off all power supplying this equipment before working on or inside it. Consider all sources of power, including the possibility of backfeeding.
- Always use a properly rated voltage sensing device to confirm that all power is off.
- Start by connecting the device to the protective earth and to the functional earth.
- Screw tight all terminals, even those not in use.

Failure to follow these instructions will result in death or serious injury.

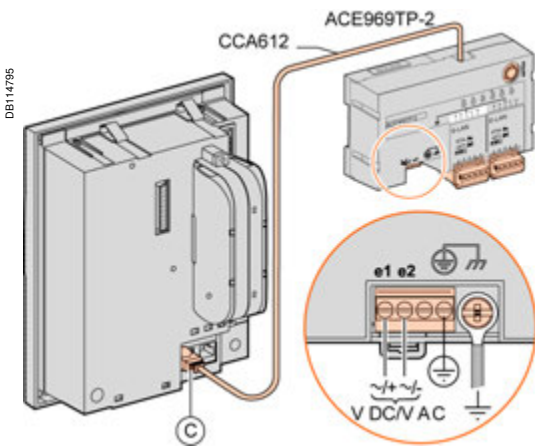

Terminals	Type	Wiring
e1-e2 - supply	Screw terminals	<ul style="list-style-type: none"> ■ Wiring with no fittings: <ul style="list-style-type: none"> □ 1 wire with maximum cross-section 0.2 to 2.5 mm² (≥ AWG 24-12) or 2 wires with maximum cross-section 0.2 to 1 mm² (≥ AWG 24-18) □ stripped length: 8 to 10 mm (0.31 to 0.39 in) ■ Wiring with fittings: <ul style="list-style-type: none"> □ recommended wiring with Schneider Electric fitting: <ul style="list-style-type: none"> - DZ5CE015D for 1 wire 1.5 mm² (AWG 16) - DZ5CE025D for 1 wire 2.5 mm² (AWG 12) - AZ5DE010D for 2 wires 1 mm² (AWG 18) □ tube length: 8.2 mm (0.32 in) □ stripped length: 8 mm (0.31 in).
Protective earth	Screw terminal	1 green/yellow wire, max. length 3 m (9.8 ft) and max. cross-section 2.5 mm ² (AWG 12)
Functional earth	4 mm (0.16 in) ring lug	Earthing braid, supplied for connection to cubicle grounding

ACE969TP-2 and ACE969FO-2 Multi-protocol interfaces Connection

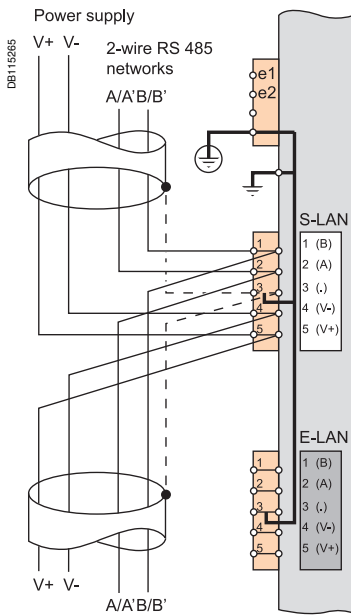

If ACE969TP and ACE969TP-2 are used together, the external power supply is required.

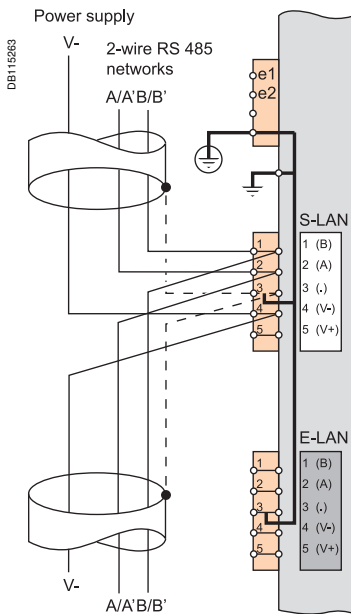

2-wire RS 485 communication ports (S-LAN or E-LAN)

- Connection of the RS 485 twisted pair (S-LAN or E-LAN) to terminals A and B
- In case of ACE 969TP wired with ACE969TP-2:
 - connection of twisted pair for distributed power supply to terminals 5(V+) et 4(V-)
 - In case of ACE969TP-2 only:
 - connection only on the terminal 4(V-) (ground continuity)
 - no need of external power supply
 - The cable shields must be connected to the terminals marked 3(.) on the connection terminal blocks.
 - Terminal marked 3(.) are linked by an internal connection to the earthing terminals of the ACETP-2 interface (protective and functional earthing): i.e the shielding of the RS 485 cables is earthed as well.
 - On the ACE960TP-2 interface, the cable clamps for the S-LAN and E-LAN RS 485 networks are earthed by the terminal 3.

ACE969TP-2 and ACE969FO-2 Multi-protocol interfaces Connection

DE52165

Raccordement en anneau

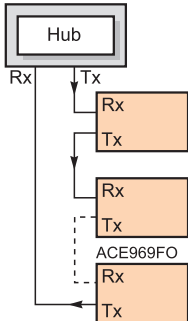

Raccordement en étoile optique

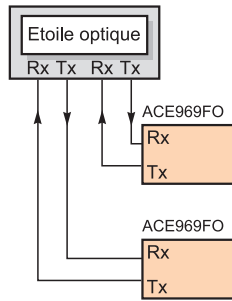

Fiber optic communication port (S-LAN)

⚠ CAUTION

HAZARD OF BLINDING

Never look directly into the fiber optic.

Failure to follow these instructions can result in injury.

The fiber optic connection can be made:

- point-to-point to an optic star system
- in a ring system (active echo).

The sending and receiving fiber optic fibers must be equipped with male ST type connectors.

The fiber optics are screw-locked to Rx and Tx connectors.

ACE850TP and ACE850FO Multi-protocol interfaces

PB105301



ACE850TP communication interface.

PB105300



ACE850FO communication interface.

Function

The ACE850 multi-protocol communication interfaces are for Sepam series 40, Sepam series 60 and Sepam series 80.

ACE850 interfaces have two Ethernet communication ports to connect a Sepam to a single Ethernet network depending on the topology (star or ring):

- For a star topology, only one communication port is used.
- For a ring topology, both Ethernet communication ports are used to provide redundancy. This redundancy conforms to the RSTP 802.1d 2004 standard.

Either port can be used for connection:

- To the S-LAN (Supervisory Local Area Network) port to connect Sepam to an Ethernet communication network dedicated to supervision, using one of the two following protocols:
 - IEC 61850
 - Modbus TCP/IP TR A15
- To the E-LAN (Engineering Local Area Network) port, reserved for Sepam remote parameter setting and operation using the SFT2841 software

There are two versions of the ACE850 interfaces, which are identical except for the type of port featured:

- ACE850TP (Twisted Pair), for connection to an Ethernet network (S-LAN or E-LAN) using a copper RJ45 10/100 Base TX Ethernet link
- ACE850FO (Fiber Optic), for connection to an Ethernet network (S-LAN or E-LAN) using a 100Base FX fiber-optic connection (star or ring)

Compatible Sepam

The ACE850TP and ACE850FO multi-protocol communication interfaces are compatible with:

- Sepam series 40 version \geq V7.00
- Sepam series 60 all versions
- Sepam series 80 base version and application version \geq V6.00

The ACE850 multi-protocol communication interfaces will only work if TCP/IP firmware option (ref. 59754) has been ordered with Sepam series 40, Sepam series 60 or Sepam series 80.

Characteristics

ACE850TP and ACE850FO module

Technical characteristics

Weight	0.4 kg (0.88 lb)	
Assembly	On symmetrical DIN rail	
Operating temperature	-25°C to +70°C (-13°F to +158°F)	
Environmental characteristics	Same characteristics as Sepam base units	

Power supply

Voltage	24 to 250 V DC	110 to 240 V AC
Range	-20%/+10%	-20%/+10%
Maximum consumption	ACE850TP 3.5 W in DC	1.5 VA in AC
	ACE850FO 6.5 W in DC	2.5 VA in AC
Inrush current	< 10 A 10 ms in DC	< 15 A 10 ms in AC
Acceptable ripple content	12%	
Acceptable momentary outages	100 ms	

Wired Ethernet communication ports (ACE850TP)

Number of ports	2 x RJ45 ports
Type of port	10/100 Base TX
Protocols	HTTP, FTP, SNMP, SNTIP, ARP, SFT, IEC 61850, TCP/IP, RSTP 801.1d 2004
Baud rate	10 or 100 Mbps
Medium	Cat 5 STP or FTP or SFTP
Maximum distance	100 m (328 ft)

Fiber-optic Ethernet communication ports (ACE850FO)

Number of ports	2				
Type of port	100 Base FX				
Protocols	HTTP, FTP, SNMP, SNTIP, ARP, SFT, IEC 61850, TCP/IP, RSTP 801.1d 2004				
Baud rate	100 Mbps				
Fiber type	Multimode				
Wavelength	1300 nm				
Type of connector	SC				
Fiber optic diameter (µm)	Tx minimum optical power (dBm)	Tx maximum optical power (dBm)	RX sensitivity (dBm)	RX saturation (dBm)	Maximum distance
50/125	-22.5	-14	-33.9	-14	2 km (1.24 mi)
62.5/125	-19	-14	-33.9	-14	2 km (1.24 mi)

Dimensions

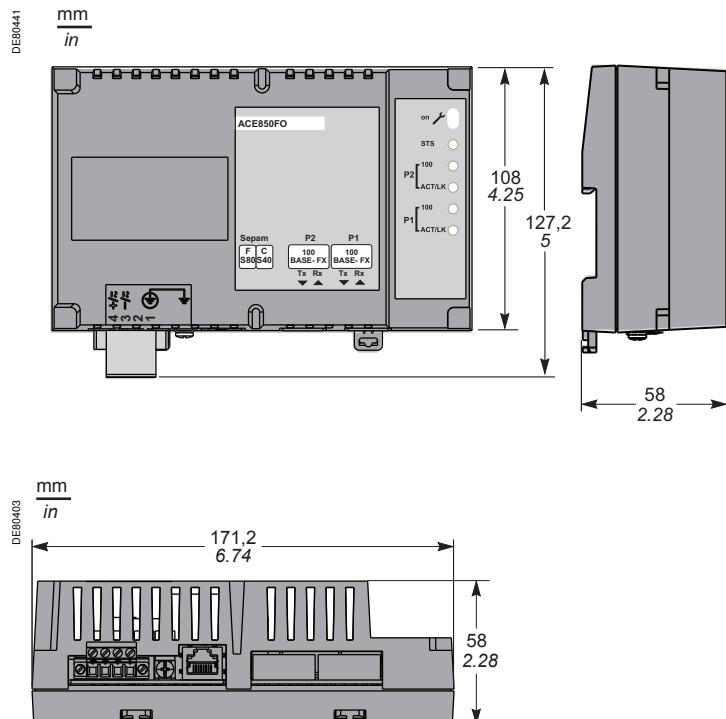

ACE850TP and ACE850FO Multi-protocol interfaces Description

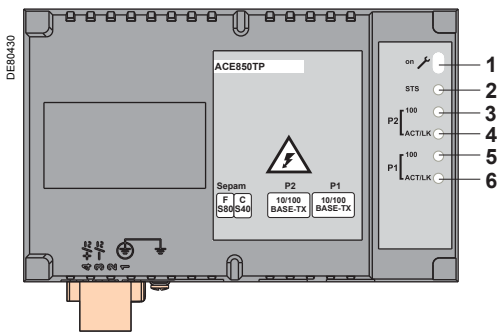

ACE850TP: Front view.

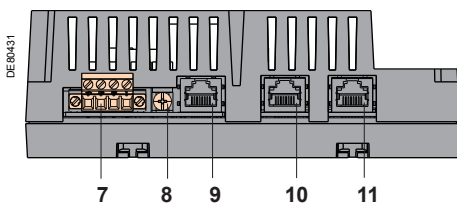

ACE850TP: View of underside.

ACE850TP communication interface

- 1 ACE850 communication interface status LED
 - LED off = ACE850 de-energized
 - Green LED permanently on = ACE850 energized and operational
 - Red LED flashing = ACE850 not configured and/or not connected to the base unit
 - Red LED permanently on = ACE850 not operational (initialization in progress or failed)
 - 2 STS LED: communication status: green permanently on = OK
 - 3 Ethernet Port 2 100 green LED: off = 10 Mbps, permanently on = 100 Mbps
 - 4 Ethernet Port 2 activity LED: flashing on transmission/reception
 - 5 Ethernet Port 1 100 green LED: off = 10 Mbps, permanently on = 100 Mbps
 - 6 Ethernet Port 1 activity LED: flashing on transmission/reception
-
- 7 Power-supply terminal block
 - 8 Grounding/earthing terminal using supplied braid
 - 9 RJ45 socket to connect the interface to the Sepam base unit with the CCA614 cord:
 - Sepam series 40: communication port (C) (identified by a white label on the Sepam unit)
 - Easergy Sepam series 60 and series 80: communication port (F) (identified by a blue label on the Sepam unit)
 - 10 RJ45 10/100 Base TX Ethernet communication port P2 (E-LAN or S-LAN)
 - 11 RJ45 10/100 Base TX Ethernet communication port P1 (E-LAN or S-LAN)

ACE850FO communication interface

- 1 ACE850 communication interface status LED
 - LED off = ACE850 de-energized
 - Green LED permanently on = ACE850 energized and operational
 - Red LED flashing = ACE850 not configured and/or not connected to the base unit
 - Red LED permanently on = ACE850 not operational (initialization in progress or failed)
 - 2 STS LED: communication status: green permanently on = OK
 - 3 Ethernet Port 2 100 green LED: permanently on = 100 Mbps
 - 4 Ethernet Port 2 activity LED: flashing on transmission/reception
 - 5 Ethernet Port 1 100 green LED: permanently on = 100 Mbps
 - 6 Ethernet Port 1 activity LED: flashing on transmission/reception
-
- 7 Power-supply terminal block
 - 8 Grounding/earthing terminal using supplied braid
 - 9 RJ45 socket to connect the interface to the Sepam base unit with a CCA614 cord:
 - Sepam series 40: communication port (C) (identified by a white label on the Sepam unit)
 - Easergy Sepam series 60 and series 80: communication port (F) (identified by a blue label on the Sepam unit)
 - 12 Tx fiber of 100 Base FX SC connector for Ethernet communication port P2 (E-LAN or S-LAN)
 - 13 Rx fiber of 100 Base FX SC connector for Ethernet communication port P2 (E-LAN or S-LAN)
 - 14 Tx fiber of 100 Base FX SC connector for Ethernet communication port P1 (E-LAN or S-LAN)
 - 15 Rx fiber of 100 Base FX SC connector for Ethernet communication port P1 (E-LAN or S-LAN)

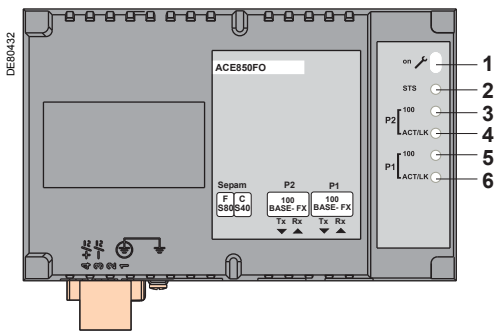

ACE850FO: Front view.

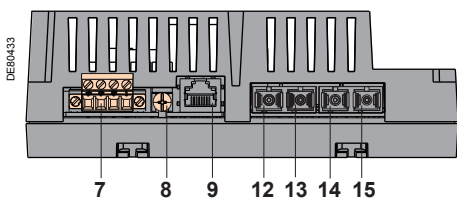

ACE850FO: View of underside.

⚠ CAUTION

HAZARD OF BLINDING

Never look directly into the end of the fiber optic.

Failure to follow these instructions can result in injury.

ACE850TP and ACE850FO Multi-protocol interfaces Connection

DE80444

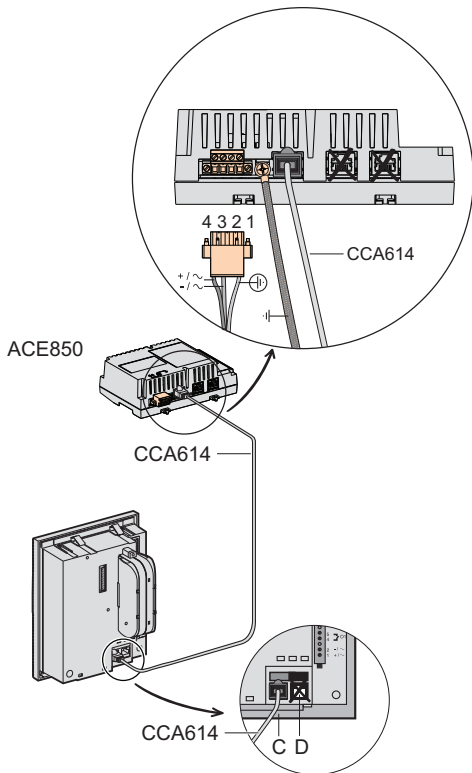

Connecting the ACE850 to Sepam series 40.

Connection to Sepam

- The ACE850 communication interface should only be connected to Sepam series 40, Easergy Sepam series 60 or 80 base units using a CCA614 prefabricated cord (length = 3 m or 9.8 ft, blue RJ45 fittings).
- Sepam series 40: Connect the CCA614 cord to connector (C) on the Sepam base unit (white label).
- Easergy Sepam series 60 or series 80: Connect the CCA614 cord to connector (F) on the Sepam base unit (blue label).

Connection of power supply

The ACE850 interfaces must be supplied with 24 to 250 V DC or 110 to 240 V AC.

⚡ ⚠ DANGER

HAZARD OF ELECTRIC SHOCK, ELECTRIC ARC OR BURNS

- Only qualified personnel should install this equipment. Such work should be performed only after reading this entire set of instructions and checking the technical characteristics of the device.
- NEVER work alone.
- Turn off all power supplying this equipment before working on or inside it. Consider all sources of power, including the possibility of backfeeding.
- Always use a properly rated voltage sensing device to confirm that all power is off.
- Start by connecting the device to the protective ground and to the functional ground.
- Screw tight all terminals, even those not in use.

Failure to follow these instructions will result in death or serious injury.

DE80445

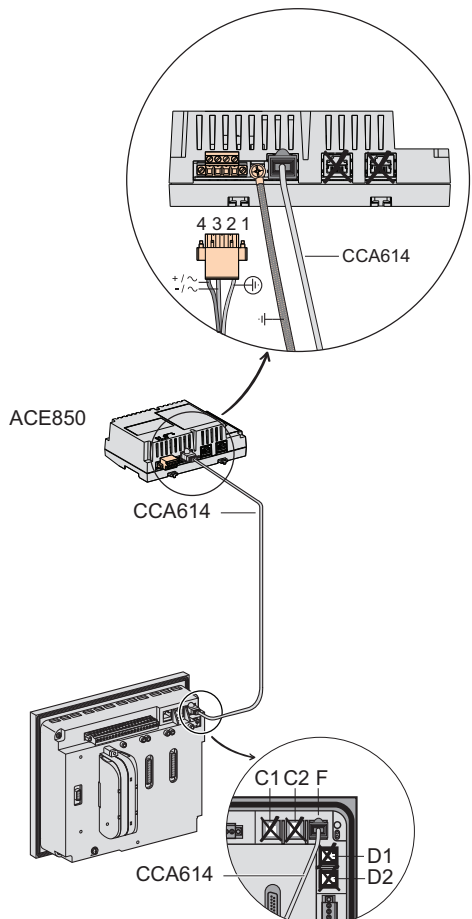

Connecting the ACE850 to Easergy Sepam series 60 or series 80.

Terminal	Assignment	Type	Wiring
3	-/~	Screw terminals	<ul style="list-style-type: none"> ■ Wiring without fittings: <ul style="list-style-type: none"> □ 1 wire with maximum cross-section 0.5 to 2.5 mm² (≥ AWG 20-12) or 2 wires with maximum cross-section 0.5 to 1 mm² (≥ AWG 20-18) □ Stripped length: 8 to 10 mm (0.31 to 0.39 in) ■ Wiring with fittings: <ul style="list-style-type: none"> □ Recommended wiring with Schneider Electric fitting: <ul style="list-style-type: none"> - DZ5CE015D for 1 wire 1.5 mm² (AWG 16) - DZ5CE025D for 1 wire 2.5 mm² (AWG 12) - AZ5DE010D for 2 wires 1 mm² (AWG 18) □ Tube length: 8.2 mm (0.32 in) □ Stripped length: 8 mm (0.31 in)
4	+/~		
1		Screw terminal	1 green/yellow wire, max. length 3 m (9.8 ft) and max. cross-section 2.5 mm ² (AWG 12)
DE51845		4 mm (0.16 in) ring lug	Earthing braid (supplied) for connection to cubicle grounding

ACE850TP and ACE850FO Multi-protocol interfaces Connection

ACE850TP or ACE850FO communication architectures

Performance

Redundancy performance tests have been conducted using RuggedCom switches (RS900xx, RSG2xxx family), compatible with RSTP 802.1d 2004.

To ensure optimum performance of the protection system during communication between Sepam units via GOOSE messages, we strongly recommend setting up a fault-tolerant fiber-optic ring structure as shown in the connection examples.

Note: Protection performance during communication between Sepam units via GOOSE message is only ensured by using:

- Fiber-optic connections
- IEC 61850-compatible managed Ethernet switches

ROOT Ethernet switch

The ROOT Ethernet switch is the master switch of the RSTP reconfiguration function:

- A single ROOT Ethernet switch per Ethernet network, in the main loop of the network
- A Sepam unit must not be the ROOT Ethernet switch of the network

Example of Sepam units connected in a star configuration

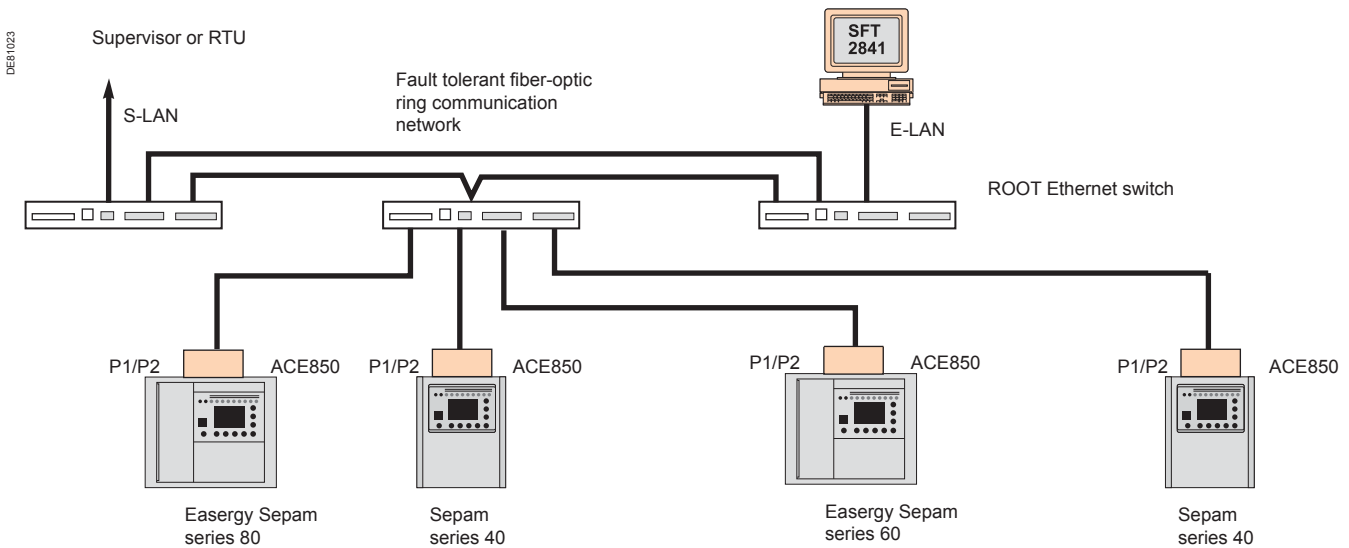

ACE850TP and ACE850FO Multi-protocol interfaces Connection

Example of Sepam units connected in a ring configuration

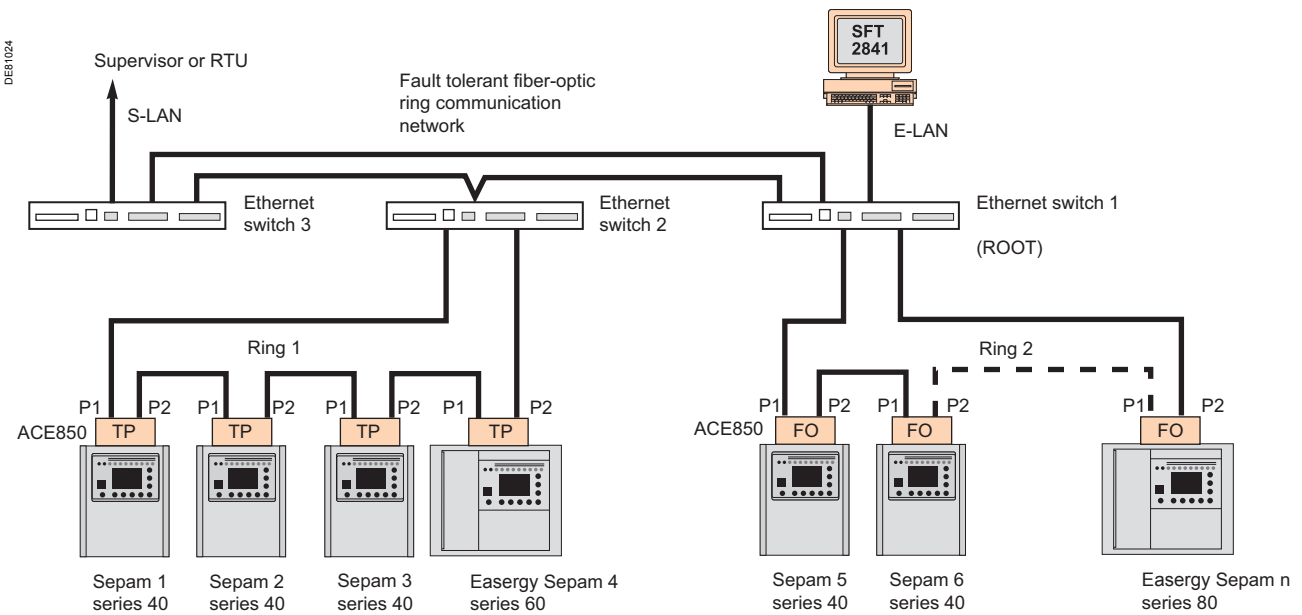

Recommendations for connecting Sepam units in ring configuration

When connecting Sepam units in the same ring configuration, the ACE850 interfaces must be of the same type (either ACE850TP or ACE850FO).

In the worst-case scenario, each Sepam unit must not be separated by more than 30 communicating devices connected to the network (other Sepam units or Ethernet switches) from the ROOT Ethernet switch.

A worst-case analysis must be performed for all the Sepam units in each network topology.

Example:

- In the best-case scenario, Sepam 2 of ring 1 is separated from the ROOT Ethernet switch by 2 devices: switch 2 and Sepam 1.
- In the worst-case scenario, i.e. if the connections between switches 1 and 2 and between Sepam units 1 and 2 of ring 1 are broken, Sepam 2 of ring 1 will be separated from the ROOT Ethernet switch by 4 devices: switch 3, switch 2, Sepam 4 and Sepam 3.

ACE909-2 RS 232/RS 485 converter

PE80317



ACE909-2 RS 232/RS 485 converter.

Function

The ACE909-2 converter is used to connect a master/central computer equipped with a V24/RS 232 type serial port as a standard feature to stations connected to a 2-wire RS 485 network.

Without requiring any flow control signals, after the parameters are set, the ACE909-2 converter performs conversion, network polarization and automatic dispatching of frames between the master and the stations by two-way simplex (half-duplex, single-pair) transmission.

The ACE909-2 converter also provides a 12 V DC or 24 V DC supply for the distributed power supply of the Sepam ACE949-2, ACE959 or ACE969-2 interfaces. The communication settings should be the same as the Sepam and supervisor communication settings.

Characteristics

Mechanical characteristics

Weight	0.280 kg (0.617 lb)
Assembly	On symmetrical or asymmetrical DIN rail

Electrical characteristics

Power supply	110 to 220 V AC \pm 10%, 47 to 63 Hz
Galvanic isolation between ACE power supply and frame, and between ACE power supply and interface supply	2000 Vrms, 50 Hz, 1 min
Galvanic isolation between RS 232 and RS 485 interfaces	1000 Vrms, 50 Hz, 1 min
Protection by time-delayed fuse 5 mm x 20 mm (0.2 in x 0.79 in)	1 A rating

Communication and Sepam interface distributed supply

Data format	11 bits: 1 start, 8 data, 1 parity, 1 stop
Transmission delay	< 100 ns
Distributed power supply for Sepam interfaces	12 V DC or 24 V CC, 250 mA max.
Maximum number of Sepam interfaces with distributed supply	12

Environmental characteristics

Operating temperature	-5°C to +55°C (+23°F to +131°F)
-----------------------	---------------------------------

Electromagnetic compatibility

	IEC standard	Value
Fast transient bursts, 5 ns	60255-22-4	4 kV with capacitive coupling in common mode 2 kV with direct coupling in common mode 1 kV with direct coupling in differential mode
1 MHz damped oscillating wave	60255-22-1	1 kV common mode 0.5 kV differential mode
1.2/50 μ s impulse waves	60255-5	3 kV common mode 1 kV differential mode

⚠ ⚠ DANGER

HAZARD OF ELECTRIC SHOCK, ELECTRIC ARC OR BURNS

■ Only qualified personnel should install this equipment. Such work should be performed only after reading this entire set of instructions and checking the technical characteristics of the device.

■ NEVER work alone.

■ Turn off all power supplying this equipment before working on or inside it. Consider all sources of power, including the possibility of backfeeding.

■ Always use a properly rated voltage sensing device to confirm that all power is off.

■ Start by connecting the device to the protective earth and to the functional earth.

■ Screw tight all terminals, even those not in use.

Failure to follow these instructions will result in death or serious injury.

ACE909-2 RS 232/RS 485 converter

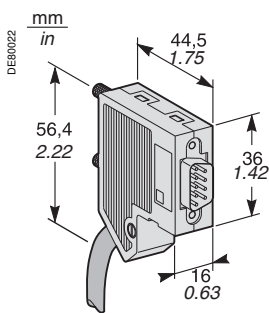
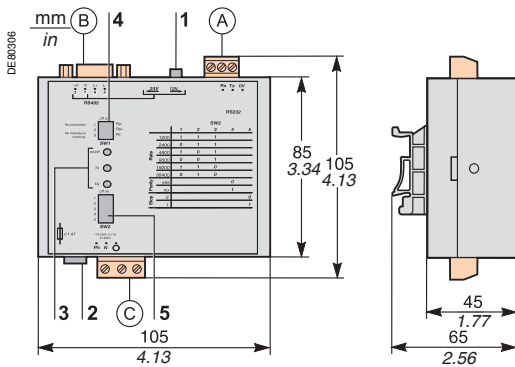

Male 9-pin sub-D connector supplied with the ACE909-2.

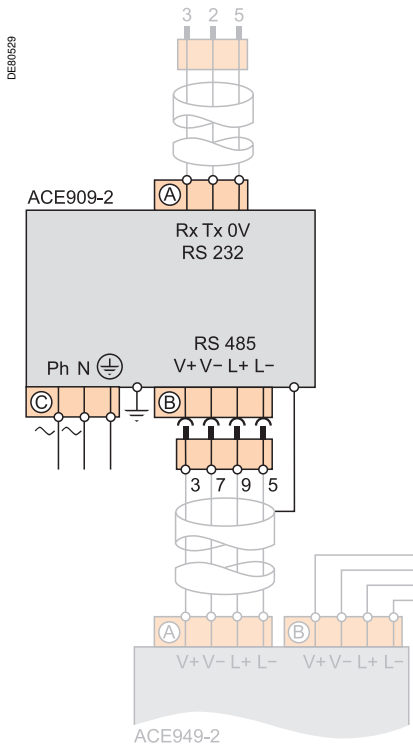

Description and dimensions

- (A) Terminal block for RS 232 link limited to 10 m (33 ft).
- (B) Female 9-pin sub-D connector to connect to the 2-wire RS 485 network, with distributed power supply.
1 screw-type male 9-pin sub-D connector is supplied with the converter.
- (C) Power-supply terminal block

- 1 Distributed power supply voltage selector switch, 12 V DC or 24 V DC.
- 2 Protection fuse, unlocked by a 1/4 turn.
- 3 LEDs:
 - ON/OFF: on if ACE909-2 is energized
 - Tx: on if RS 232 sending by ACE909-2 is active
 - Rx: on if RS 232 receiving by ACE909-2 is active.
- 4 SW1, parameter setting of 2-wire RS 485 network polarization and line impedance matching resistors.

Function	SW1/1	SW1/2	SW1/3
Polarization at 0 V via Rp -470 Ω	ON		
Polarization at 5 V via Rp +470 Ω		ON	
2-wire RS 485 network impedance matching by 150 Ω resistor			ON

- 5 SW2, parameter setting of asynchronous data transmission rate and format (same parameters as for RS 232 link and 2-wire RS 485 network).

Rate (bauds)	SW2/1	SW2/2	SW2/3	SW2/4	SW2/5
1200	1	1	1		
2400	0	1	1		
4800	1	0	1		
9600	0	0	1		
19200	1	1	0		
38400	0	1	0		
Format				SW2/4	SW2/5
With parity check				0	
Without parity check				1	
1 stop bit (compulsory for Sepam)					1
2 stop bits					0

Converter configuration when delivered

- 12 V DC distributed power supply
- 11-bit format, with parity check
- 2-wire RS 485 network polarization and impedance matching resistors activated.

Connection

RS 232 link

- To 2.5 mm² (AWG 12) screw type terminal block (A)
- Maximum length 10 m (33 ft)
- Rx/Tx: RS 232 receiving/sending by ACE909-2
- 0V: Rx/Tx common, do not earth.

2-wire RS 485 link with distributed power supply

- To connector (B) female 9-pin sub-D
- 2-wire RS 485 signals: L+, L-
- Distributed power supply: V+ = 12 V DC or 24 V DC, V- = 0 V.

Power supply

- To 2.5 mm² (AWG 12) screw type terminal block (C)
- Reversible phase and neutral
- Earthed via terminal block and metal case (ring lug on back of case).

ACE919CA and ACE919CC RS 485/RS 485 converters

PE60316



ACE919CC RS 485/RS 485 converter.

Function

The ACE919 converters are used to connect a master/central computer equipped with an RS 485 type serial port as a standard feature to stations connected to a 2-wire RS 485 network. Without requiring any flow control signals, the ACE919 converters perform network polarization and impedance matching. The ACE919 converters also provide a 12 V DC or 24 V DC supply for the distributed power supply of the Sepam ACE949-2, ACE959 or ACE969-2 interfaces. There are 2 types of ACE919 converter:

- ACE919CC, DC-powered
- ACE919CA, AC-powered.

Characteristics

Mechanical characteristics

Weight	0.280 kg (0.617 lb)	
Assembly	On symmetrical or asymmetrical DIN rail	
Electrical characteristics	ACE919CA	ACE919CC
Power supply	110 to 220 V AC ±10%, 47 to 63 Hz	24 to 48 V DC ±20%
Protection by time-delayed fuse 5 mm x 20 mm (0.2 in x 0.79 in)	1 A rating	1 A rating
Galvanic isolation between ACE power supply and frame, and between ACE power supply and interface supply		2000 Vrms, 50 Hz, 1 min

Communication and Sepam interface distributed supply

Data format	11 bits: 1 start, 8 data, 1 parity, 1 stop
Transmission delay	< 100 ns
Distributed power supply for Sepam interfaces	12 V DC or 24 V CC, 250 mA max.
Maximum number of Sepam interfaces with distributed supply	12

Environmental characteristics

Operating temperature	-5°C to +55°C (+23°F to +131°F)	
Electromagnetic compatibility	IEC standard	Value
Fast transient bursts, 5 ns	60255-22-4	4 kV with capacitive coupling in common mode 2 kV with direct coupling in common mode 1 kV with direct coupling in differential mode
1 MHz damped oscillating wave	60255-22-1	1 kV common mode 0.5 kV differential mode
1.2/50 µs impulse waves	60255-5	3 kV common mode 1 kV differential mode

DANGER

HAZARD OF ELECTRIC SHOCK, ELECTRIC ARC OR BURNS

- Only qualified personnel should install this equipment. Such work should be performed only after reading this entire set of instructions and checking the technical characteristics of the device.
- NEVER work alone.
- Turn off all power supplying this equipment before working on or inside it. Consider all sources of power, including the possibility of backfeeding.
- Always use a properly rated voltage sensing device to confirm that all power is off.
- Start by connecting the device to the protective earth and to the functional earth.
- Screw tight all terminals, even those not in use.

Failure to follow these instructions will result in death or serious injury.

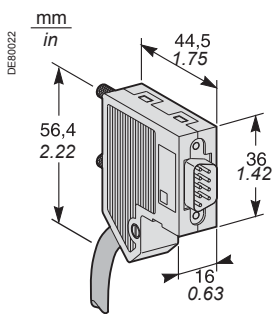
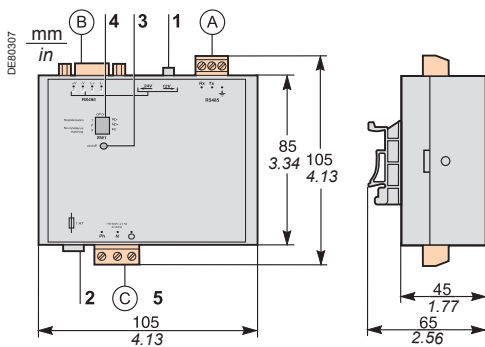

Male 9-pin sub-D connector supplied with the ACE919.

Description and dimensions

- (A) Terminal block for 2-wire RS 485 link without distributed power supply.
- (B) Female 9-pin sub-D connector to connect to the 2-wire RS 485 network, with distributed power supply.
1 screw-type male 9-pin sub-D connector is supplied with the converter.
- (C) Power supply terminal block.

- 1 Distributed power supply voltage selector switch, 12 V DC or 24 V DC.
- 2 Protection fuse, unlocked by a 1/4 turn.
- 3 ON/OFF LED: on if ACE919 is energized.
- 4 SW1, parameter setting of 2-wire RS 485 network polarization and line impedance matching resistors.

Function	SW1/1	SW1/2	SW1/3
Polarization at 0 V via Rp -470 Ω	ON		
Polarization at 5 V via Rp +470 Ω		ON	
2-wire RS 485 network impedance matching by 150 Ω resistor			ON

Converter configuration when delivered

- 12 V DC distributed power supply
- 2-wire RS 485 network polarization and impedance matching resistors activated.

Connection

2-wire RS 485 link without distributed power supply

- To 2.5 mm² (AWG 12) screw type terminal block (A)
- L+, L-: 2-wire RS 485 signals
- ≡ Shielding.

2-wire RS 485 link with distributed power supply

- To connector (B) female 9-pin sub-D
- 2-wire RS 485 signals: L+, L-
- Distributed power supply: V+ = 12 V DC or 24 V DC, V- = 0 V.

Power supply

- To 2.5 mm² (AWG 12) screw type terminal block (C)
- Reversible phase and neutral (ACE919CA)
- Earthed via terminal block and metal case (ring lug on back of case).

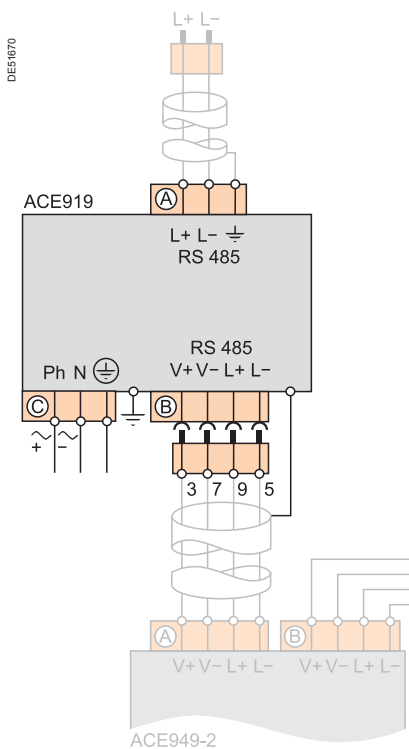

ECI850

IEC 61850 Sepam server

PE60319



ECI850: IEC 61850 Sepam server.

Not: This module is inoperative from 30 June 2017.
You can use the ACE850 communication interface on Sepam series 40, Easergy Sepam series 60 and series 80.

Function

The ECI850 can be used to connect Sepam series 20, Sepam series 40, Easergy Sepam series 60 and series 80 to an Ethernet network using the IEC 61850 protocol.

The ECI850 creates the interface between the Ethernet/IEC 61850 network and a Sepam RS 485/Modbus network.

A PRI surge arrester (ref. 16339) is supplied with the ECI850 to protect its power supply.

Compatible Sepam

The ECI850 servers are compatible with the following Sepam:

- Sepam series 20 version \geq V0526
- Sepam series 40 version \geq V3.00
- Easergy Sepam series 60 all versions
- Easergy Sepam series 80 base version and application version \geq V3.00.

Characteristics

ECI850 module	
Technical characteristics	
Weight	0.17 kg (0.37 lb)
Assembly	On symmetrical DIN rail
Power supply	
Voltage	24 V DC (\pm 10%) supplied by a class 2 power supply
Maximum consumption	4 W
Dielectric withstand	1.5 kV
Environmental characteristics	
Operating temperature	-25 °C to +70 °C (-13 °F to +158 °F)
Storage temperature	-40 °C to +85 °C (-40 °F to +185 °F)
Humidity ratio	5 to 95% relative humidity (non condensing) at +55 °C (131 °F)
Degree of pollution	Class 2
Tightness	IP30
Electromagnetic compatibility	
Emission tests	
Emissions (radiated and conducted)	EN 55022/EN 55011/FCC Class A
Immunity tests - Radiated disturbances	
Electrostatic discharge	EN 61000-4-2
Radiated radiofrequencies	EN 61000-4-3
Magnetic fields at the network frequency	EN 61000-4-8
Immunity tests - Conducted disturbances	
Fast transient bursts	EN 61000-4-4
Surges	EN 61000-4-5
Conducted radiofrequencies	EN 61000-4-6
Safety	
International	IEC 60950
USA	UL 508/UL 60950
Canada	cUL (complies with CSA C22.2, no. 60950)
Australia/New Zealand	AS/NZS 60950
Certification	
Europe	CE
2-wire/4-wire RS 485 communication port	
Electrical interface	
Standard	2-wire or 4-wire differential RS 485 EIA
Max. number of Sepam units per ECI850	2 Easergy Sepam series 80 or 2 Easergy Sepam series 60 or 3 Sepam series 40 or 5 Sepam series 20
Maximum network length	1000 m (3300 ft)
Ethernet communication port	
Number of ports	1
Type of port	10/100 Base Tx
Protocols	HTTP, FTP, SNMP, SNTIP, ARP, SFT, IEC 61850 TCP/IP
Transmission speed	10/100 Mbps

Characteristics (cont'd)

PRI surge arrester	
Electrical characteristics	
Nominal operating voltage	48 V DC
Maximum discharge current	10 kA (8/20 μs wave)
Nominal discharge current	5 kA (8/20 μs wave)
Protection level	70 V
Response time	1 ns
Connection	
With cage terminals	Cables with cross-section 2.5 to 4 mm ² (AWG 12-10)

Description

- 1 LED: power-up/maintenance
- 2 Standard LEDs:
 - RS 485 LED: network link active
 - On: RS 485 mode
 - Off: RS 232 mode
 - Flashing green Tx LED: ECI850 transmission active
 - Flashing green Rx LED: ECI850 reception active
- 3 Ethernet LEDs:
 - LK green LED on: network link active
 - Flashing green Tx LED: ECI850 transmission active
 - Flashing green Rx LED: ECI850 reception active
 - 100 green LED:
 - On: 100 Mbps network speed
 - Off: 10 Mbps network speed
- 4 10/100 Base Tx port for Ethernet connection by RJ45 connector
- 5 Connection of the 24 V DC supply
- 6 Reset button
- 7 RS 485 connection
- 8 RS 485 parameter-setting selector switches
- 9 RS 232 connection

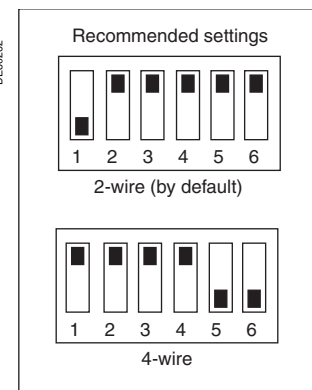
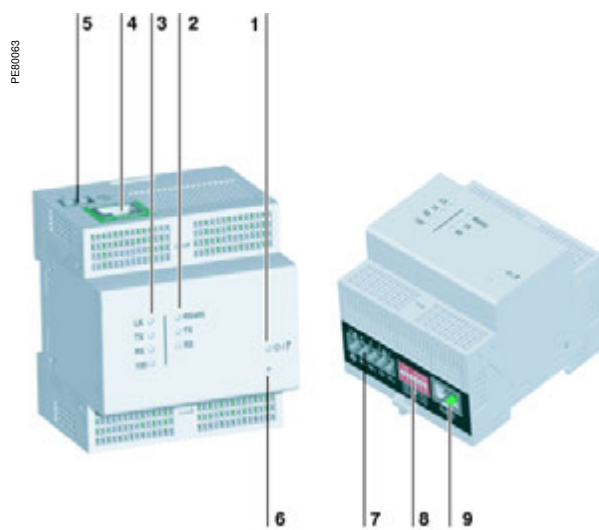

Setting the RS 485 network parameters.

Setting the RS 485 network parameters

The network polarization and line impedance matching resistors and type of 2-wire/4-wire RS 485 network are selected by means of the RS 485 parameter-setting selector switches. These selector switches are configured by default for a 2-wire RS 485 network with network polarization and line impedance matching resistors.

Network line impedance matching with resistor	SW1	SW2	SW3	SW4	SW5	SW6
2-wire RS 485	OFF	ON				
4-wire RS 485	ON	ON				

Network polarization	SW1	SW2	SW3	SW4	SW5	SW6
at the 0 V			ON			
at the 5 V				ON		

Selecting the RS 485 network	SW1	SW2	SW3	SW4	SW5	SW6
2-wire network					ON	ON
4-wire network					OFF	OFF

Setting the Ethernet link parameters

The TCSEAK0100 configuration kit can be used to connect a PC to the ECI850 to set the Ethernet link parameters.

Dimensions

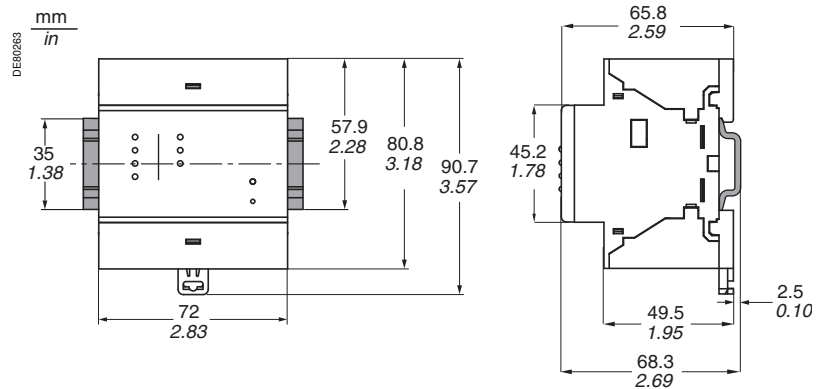

NOTICE

RISK OF DESTRUCTION OF THE ECI850

- Connect the PRI surge arrester in accordance with the wiring diagrams below.
- Check the quality of the earth connected to the surge arrester.

Failure to follow these instructions can result in equipment damage.

Connection

- Connect the power supply and RS 485 twisted pair using cable with cross-section $\leq 2.5 \text{ mm}^2$ ($\geq \text{AWG } 12$)
- Connect the 24 V DC power supply and the earth to inputs (1), (5) and (3) of the PRI surge arrester (ref. 16339) supplied with the ECI850
- Connect outputs (2), (8) and (6), (12) of the PRI surge arrester to the - and + terminals of the black screen terminal block
- Connect the RS 485 twisted pair (2-wire or 4-wire) to the (RX+ RX- or RX+ RX-TX+ TX-) terminals of the black screw terminal block
- Connect the RS 485 twisted pair shielding to the \oplus terminal of the black screw terminal block
- Connect the Ethernet cable to the green RJ45 connector

2-wire RS 485 network

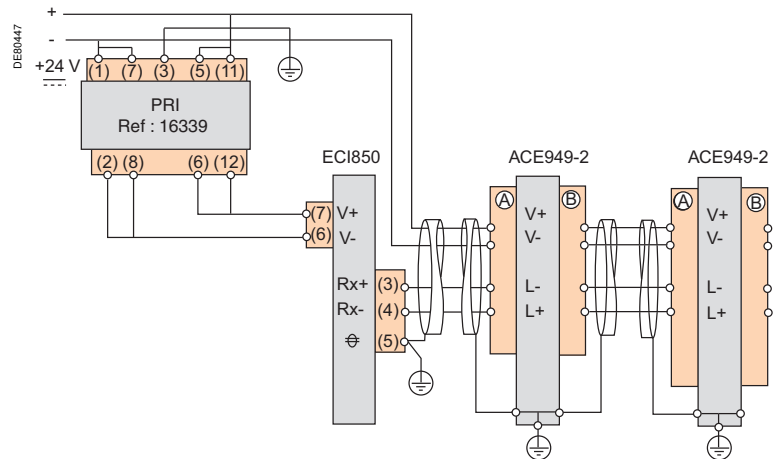

4-wire RS 485 network

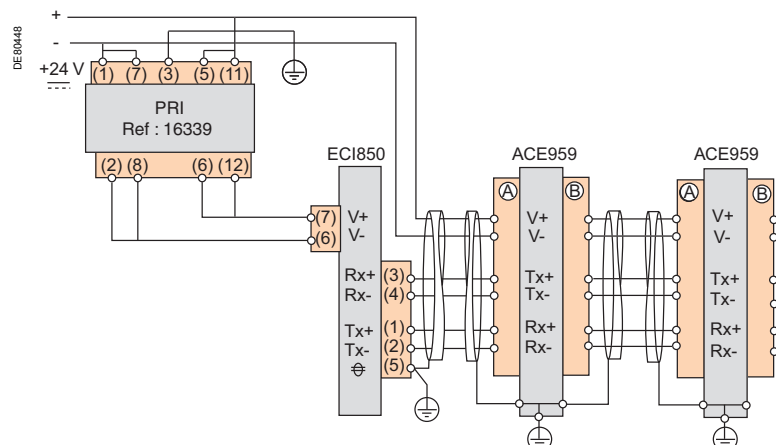

Example of architecture

The diagram below shows an example of the communication architecture with ECI850 IEC 61850 Sepam servers.

Note: R_c, line impedance matching resistor

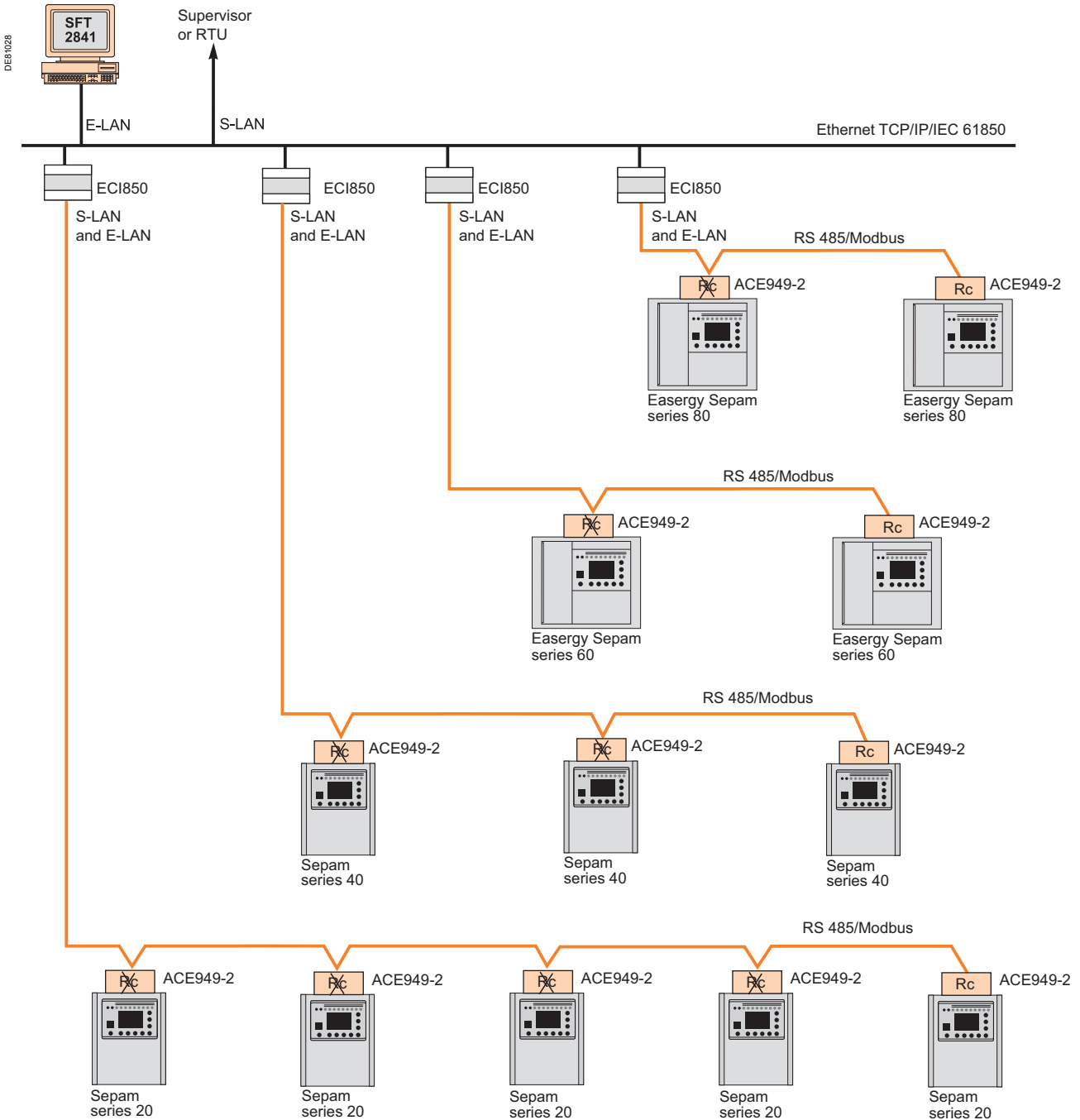

Maximum Advised Configuration

The maximum configuration of Sepam for an ECI850 IEC 61850 Sepam server of level 1 is to be chosen between the following configurations:

- 5 Sepam series 20,
- 3 Sepam series 40,
- 2 Easergy Sepam series 60,
- 2 Easergy Sepam series 80.

User Machine Interfaces	268
SFT2841 setting and operating software	269
Welcome window	
SFT2841 setting and operating software	270
Presentation	
General screen organization	271
Use of the software	272
Configuration of a Sepam network	273
UMI on front panel	278
Presentation	
Advanced UMI	279
Access to data	
White keys for current operation	280
Blue keys for parameter and protection setting	282
Data entry principles	284
Default parameters, all applications	285
Principles and methods	286
Testing and metering equipment required	287
General examination and preliminary actions	288
Checking of parameter and protection settings	289
Checking of phase current and voltage input connection	290
With 3-phase generator	
With single-phase generator and voltages delivered by 3 VTs	292
With single-phase generator and voltages delivered by 2 VTs	293
LPCT type current sensors	294
Checking of residual voltage input connection	296
Checking of residual current and residual voltage input connection	297
Checking of logic input and output connection	298
Validation of the complete protection chain	
Checking of optional modules connection	299
Test sheet	300
Maintenance	302
Firmware modifications	304

Sepam User Machine Interfaces

Two different levels of user machine interface (UMI) are offered on the front panel of Sepam:

- Basic UMI, with LEDs, for installations operated via a remote system with no need for local operation
- Advanced UMI, with keypad and graphic LCD display, giving access to all the information necessary for local operation and Sepam parameter setting.

SFT2841 setting and operating software

The UMI on the front panel of Sepam can be completed by the SFT2841 PC software tool, which can be used for all Sepam parameter setting, local operation and customization functions.

The SFT2841 setting and operating software is supplied on CD-ROM, along with the SFT2826 program for recovering disturbance recording files, the interactive introduction to the Sepam range, and all the Sepam documentation in PDF format. The CCA783 or CCA784 PC connecting cord, to be ordered separately, connects the PC to the port on the Sepam front panel, so that the SFT2841 package can be used in point-to-point connected mode.



SFT2841 setting and operating software

Welcome window

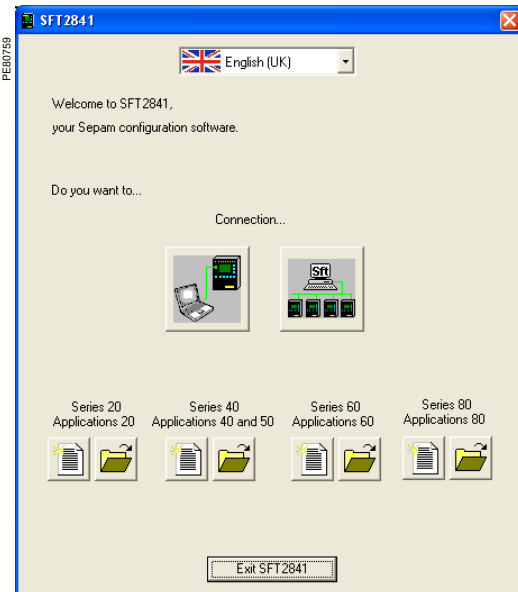

Welcome window.

Description

The SFT2841 welcome window opens when the program is launched. It lets you choose the language for the SFT2841 screens, and provides access to the Sepam parameter and protection setting files:

- In disconnected mode, you can open or create a parameter and protection setting file for a Sepam
- When connected to a single Sepam unit, you can access the parameter and protection setting file for the Sepam unit connected to the PC
- When connected to a Sepam network, you can access the parameter and protection setting files for a group of Sepam units connected to the PC via a communication network.



Language of SFT2841 screens

SFT2841 software can be used in English, French or Spanish. The language is selected at the top of the window.

Using SFT2841 in disconnected mode

Disconnected mode allows you to prepare parameters and settings files for Sepam prior to commissioning.

The parameter and protection setting files prepared in disconnected mode will be downloaded later to the Sepam units in connected mode.

- To create a new parameter and protection setting file, click on the icon  for the relevant Sepam family
- To open an existing parameter and protection setting file, click on the icon  for the relevant Sepam family.

Using SFT2841 connected to a single Sepam unit

Connected to a single Sepam unit mode is used during commissioning:

- To upload, download and modify Sepam parameters and settings
 - To have all the measurements and supporting data available for commissioning.
- The PC fitted with the SFT2841 software is connected to the port on the front panel of the Sepam via an RS 232 port using the CCA783 cord or via a USB port using the CCA784 cord.

To open the parameter and protection setting file on the Sepam once it is connected to the PC, click on the  icon.

Using SFT2841 connected to a Sepam network

Connected to a Sepam network mode is used during operation:

- To manage the protection system
- To check the status of the power supply
- To diagnose any incident occurring on the power supply.

The PC fitted with the SFT2841 software is connected to a group of Sepam units via a communication network (connection via serial link, telephone line or Ethernet). This network forms the E-LAN engineering network.

The connection window allows configuration of the Sepam network, and provides access to the parameter and protection setting files of the Sepam units on the network.

To open the connection window, click on the  icon.

See "Configuration of a Sepam network" page 273 for details of how to configure the E-LAN engineering network from the connection window.

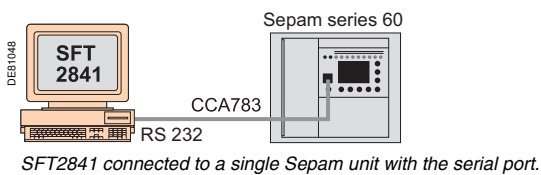

SFT2841 connected to a single Sepam unit with the serial port.

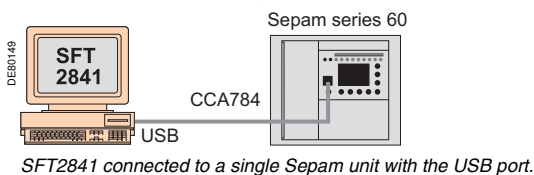

SFT2841 connected to a single Sepam unit with the USB port.

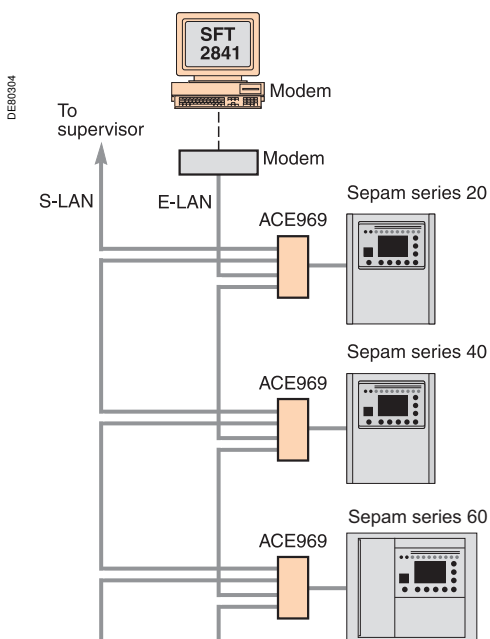

SFT2841 connected to a Sepam network.

SFT2841 setting and operating software Presentation

All the setting and operating functions are available on the screen of a PC equipped with the SFT2841 software tool and connected to the PC connection on the front panel of Sepam (run in a Windows XP or Vista environment).

All the data used for the same task are grouped together in the same screen to facilitate operation. Menus and icons are used for fast, direct access to the required information.

Current operation

- display of all metering and operation data
- display of alarm messages with the time of appearance (date, hour, mn, s, ms)
- display of diagnosis data such as: tripping current, number of switchgear operations and cumulative breaking current
- display of all the protection and parameter settings
- display of the logic status of inputs, outputs and signal lamps.

The SFT2841 software is the solution suited to occasional local operation, for demanding personnel who require fast access to all the information.

Parameter and protection setting ⁽¹⁾

- display and setting of all the parameters of each protection function in the same page
- program logic parameter setting, parameter setting of general installation and Sepam data
- input data may be prepared ahead of time and transferred into the corresponding Sepam units in a single operation (downloading function).

Main functions performed by SFT2841:

- changing of passwords
- entry of general characteristics (ratings, integration period, ...)
- setting Sepam date and time
- entry of protection settings
- changing of program logic assignments
- enabling/disabling of functions
- saving of files.

Saving

- protection and parameter setting data may be saved
- printing of reports is possible as well.

The SFT2841 software may also be used to recover disturbance recording files and provide graphic display using the SFT2826 software tool.

Operating assistance

Access from all the screens to a help section which contains all the technical data required for Sepam installation and use.

(1) Modes accessed via 2 passwords (protection setting level, parameter setting level).



Example of a measurement display screen.

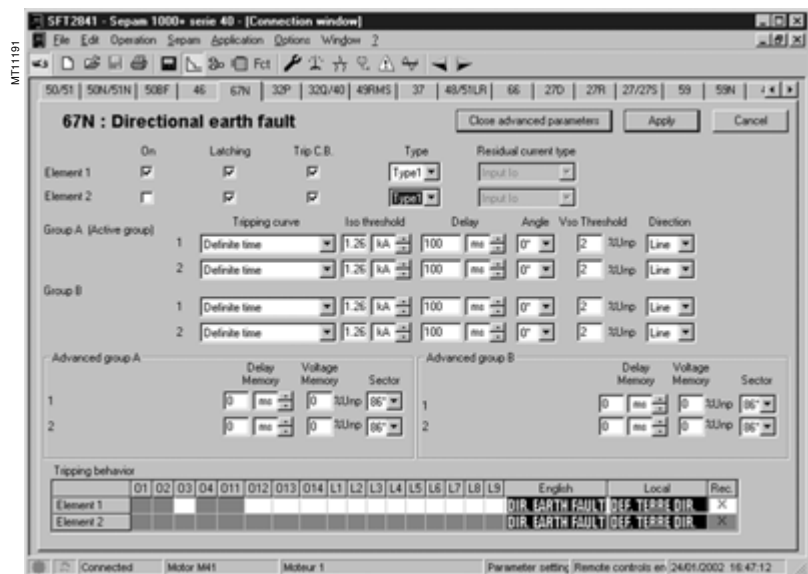

Example of a protection setting screen.

SFT2841 setting and operating software

General screen organization

A Sepam document is displayed on the screen via a graphic interface that has the conventional Windows features.

All the SFT2841 software screens are set up in the same way, i.e.:

- (A): title bar, with:
 - name of the application (SFT2841)
 - identification of the Sepam document displayed
 - window manipulation handles
- (B): menu bar, to access all the SFT2841 software functions (unavailable functions are dimmed)
- (C): toolbar, a group of contextual icons for quick access to the main functions (also accessed via the menu bar)
- (D): work zone available to the user, presented in the form of tab boxes
- (E): status bar, with the following information relating to the active document:
 - alarm on
 - identification of the connection window
 - SFT2841 operating mode, connected or not connected,
 - type of Sepam
 - Sepam editing identification
 - identification level
 - Sepam operating mode
 - PC date and time.

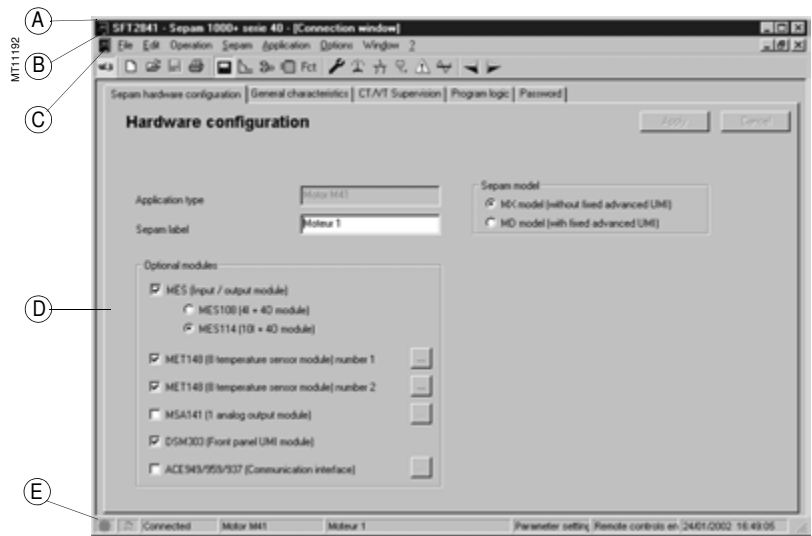

Example of Sepam configuration screen.

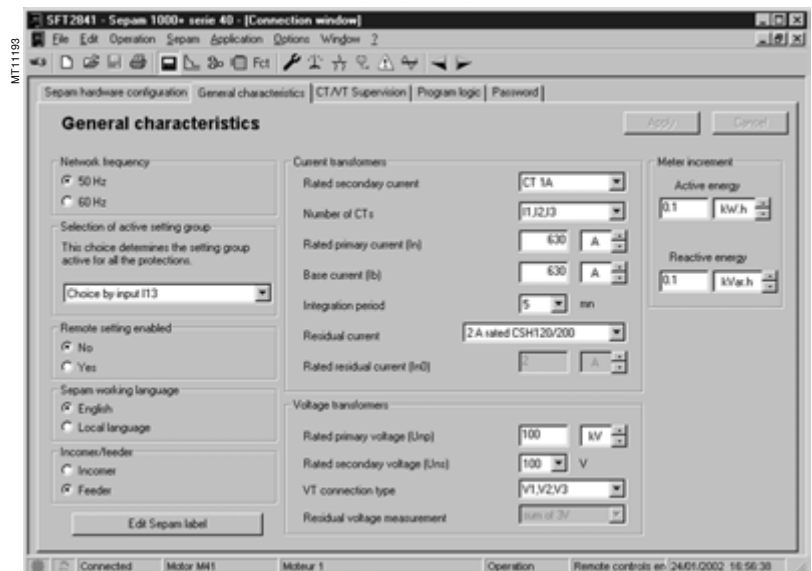

Example of general characteristics screen.

Guided navigation

A guided navigation mode is proposed to make it easier to enter all of the Sepam parameter and protection settings. It allows users to go through all the data input screens in the natural order.

The sequencing of the screens in guided mode is controlled by clicking on 2 icons in the toolbar (C):

- ◀: to go back to the previous screen
- ▶: to go to the next screen.

The screens are linked up in the following order:

1. Sepam hardware configuration
2. General characteristics
3. CT/VT supervision
4. Program logic
5. Password
6. Setting screens for the protection functions available, according to the type of Sepam
7. Logical equation editor
8. Various tabs of the control matrix
9. Disturbance recording setup.

On-line help

The operator may look up on-line help at any time via the "?" command in the menu bar.

To use the on-line help, a browser such as Netscape Navigator or Internet Explorer MS is required.

Not connected to Sepam mode

Sepam parameter and protection setting

The parameter and protection setting of a Sepam using SFT2841 consists of preparing the Sepam file containing all the characteristics that are specific to the application, a file that is then downloaded into Sepam at the time of commissioning.

NOTICE

HAZARD OF UNINTENDED OPERATION

- The device must only be configured and set by qualified personnel, using the results of the installation protection system study.
- During commissioning of the installation and after any modification, check that the Sepam configuration and protection function settings are consistent with the results of this study.

Failure to follow these instructions can result in equipment damage.

Operating mode:

1. Create a Sepam file for the type of Sepam to be set up (the newly created file contains the Sepam factory-set parameter and protection settings).
2. Modify the Sepam general settings and protection function settings:
 - all the data relating to the same function are grouped together in the same screen
 - it is advisable to enter all the parameters and protection settings in the natural order of the screens proposed by the guided navigation mode.

Entry of parameter and protection settings:

- the parameter and protection setting input fields are suited to the type of value:
 - choice buttons
 - numerical value input fields
 - dialogue box (Combo box)
- the user must "Apply" or "Cancel" the new values entered before going on to the following screen
- the consistency of the new values applied is checked:
 - an explicit message identifies inconsistent values and specifies the authorized values
 - values that have become inconsistent following a parameter modification are adjusted to the closest consistent value.

Connected to Sepam mode

Precaution

When a laptop is used, given the risks inherent to the accumulation of static electricity, the customary precaution consists of discharging in contact with an earthed metal frame before physically connecting the CCA783 cord.

Note: If you are unable to connect to Sepam, check that the SFT2841 software version used is actually compatible with your Sepam. (see "Compatibility of Sepam version/SFT2841 version" page 303).

Plugging into Sepam

- plugging of the 9-pin connector (SUB-D type) into one of the PC communication ports. Configuration of the PC communication port via the "Communication port" function in the "Options" menu
- plugging of the 6-pin connector into the connector (round minidin type) situated behind the blanking plate on the front panel of Sepam or the DSM303 module.

Connection to Sepam

2 possibilities for setting up the connection between SFT2841 and Sepam:

- "Connection" function in the "File" menu
 - choice of "connect to the Sepam" at the start-up of SFT2841.
- Once the connection with Sepam has been established, "Connected" appears in the status bar, and the Sepam connection window may be accessed in the work zone.

User identification

The window intended for the entry of the 4-digit password is activated:

- via the "Passwords" tab
- via the "Identification" function in the "Sepam" menu
- via the "Identification" icon 

The "Return to Operating mode" function in the "Passwords" tab removes access rights to parameter and protection setting mode.

Downloading of parameters and protection settings

Parameter and protection setting files may only be downloaded in the connected Sepam in Parameter setting mode.

Once the connection has been established, the procedure for downloading a parameter and protection setting file is as follows:

1. Activate the "Download Sepam" function in the "Sepam" menu.
2. Select the file (*.S40, *.S41, *.S42, *.S43, *.S44, *.S50, *.S51, *.S52, *.S53, *.S54, *.T40, *.T42, *.T50, *.T52, *.M40, *.M41, *.G40 according to the type of application) which contains the data to be downloaded.

Return to factory settings

This operation is only possible in Parameter setting mode, via the "Sepam" menu. All of the Sepam general characteristics, protection settings and the control matrix go back to the default values.

Uploading of parameter and protection settings

The connected Sepam parameter and protection setting file may only be uploaded in Operating mode.

Once the connection has been established, the procedure for uploading a parameter and protection setting file is as follows:

1. Activate the "Upload Sepam" function in the "Sepam" menu.
2. Select the *.rpg file that is to contain the uploaded data.
3. Acknowledge the end of operation report.

Local operation of Sepam

Connected to Sepam, SFT2841 offers all the local operating functions available in the advanced UMI screen, plus the following functions:

- setting of Sepam internal clock, via the "general characteristics" tab
- implementation of the disturbance recording function, via the "Fault recording" menu "OPG": validation/inhibition of the function, recovery of Sepam files, start-up of SFT2826
- consultation of the history of the last 64 Sepam alarms, with time-tagging
- access to Sepam diagnostic data, in the "Sepam" tab box, included in "Sepam diagnosis"
- in Parameter setting mode, the switchgear diagnostic values may be modified: operation counter, cumulative breaking current to reset the values after a change of breaking device.

SFT2841 setting and operating software

Configuration of a Sepam network

Connection window

The SFT2841 software connection window is used:

- To select an existing Sepam network or configure a new one
- To set up the connection to the selected Sepam network
- To select one Sepam unit from the network and access its parameters, settings, and operation and maintenance information.

Configuration of a Sepam network

Several configurations can be defined for the various Sepam installations.

A Sepam network configuration is identified by a name. It is saved on the SFT2841 PC in a file in the SFT2841 installation directory (default: C:\Program Files\Schneider\SFT2841\Net).

Configuration of a Sepam network is in 2 parts:

- Configuration of the communication network
- Configuration of the Sepam units.

Configuration of the communication network

To configure the communication network, first define:

- The type of link between the PC and the Sepam network
- The communication parameters, according to the type of link selected:
 - direct serial link
 - link via Ethernet TCP/IP

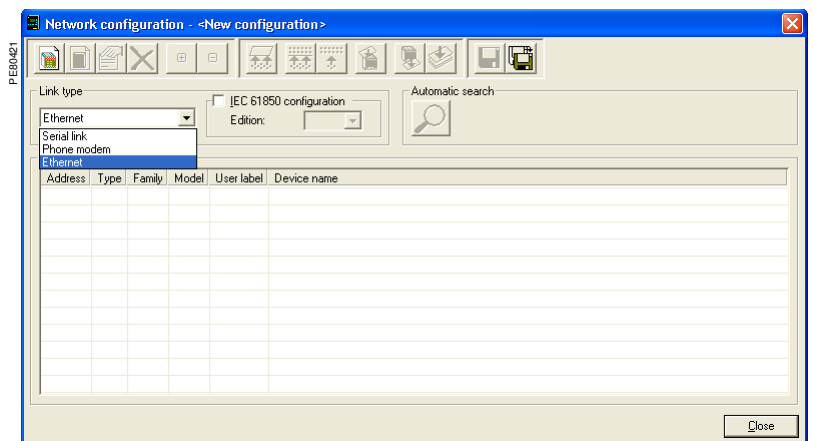

Configuration windows for the communication network, according to the type of link: serial link or Ethernet link (TCP).

SFT2841 setting and operating software

Configuration of a Sepam network

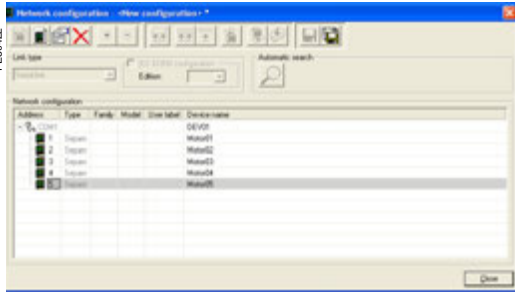

Configuration window for the serial link communication network.

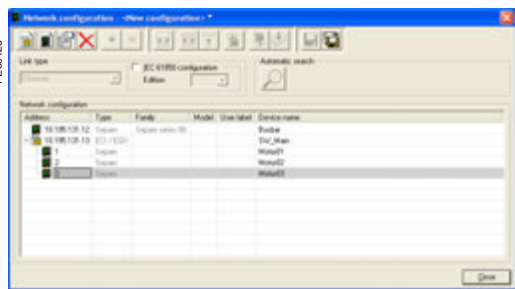

Configuration window for the Ethernet TCP/IP communication network.

Direct serial link

The Sepam units are connected to an RS 485 (or fiber-optic) multidrop network. Depending on the serial link interfaces available on the PC, the PC itself will be connected either directly to the RS 485 network (or fiber-optic HUB), or via an RS 232/RS 485 converter (or fiber-optic converter).

The communication parameters to be defined are:

- port: communication port used on the PC
- speed: 4800, 9600, 19200 or 38400 bauds
- parity: None, Even or Odd
- handshake: None, RTS or RTS-CTS
- time-out: from 100 to 3000 ms.
- number of retries: from 1 to 6.

Link via TCP/IP Ethernet

The Sepam units are connected to an RS 485 multidrop network over one or more Ethernet Modbus TCP/IP gateways (for example: EGX gateways or ECI850 servers that act as the Modbus TCP/IP gateway for the link with the SFT2841).

Use on an IEC 61850 network

SFT2841 can be used on an IEC 61850 network. In this case, it can be used to define the IEC 61850 configuration of Sepam connected to this network. See the Sepam IEC 61850 Communication user's manual (reference SEPED306024EN) for more information.

Configuration of the Modbus TCP/IP gateway

See the setup manual for the gateway used.

In general, the gateway should be assigned an IP address.

The configuration parameters for the gateway's RS 485 interface must be defined in accordance with the Sepam communication interface configuration:

- speed: 4800, 9600, 19200 or 38400 bauds
- character format: 8 data bits + 1 stop bit + parity (none, even, odd).

Configuration of communication on SFT2841

When configuring a Sepam network on SFT2841, the following communication parameters must be defined:

- type of device: Modbus gateway, ECI850 or Sepam
- IP address: IP address for the connected remote equipment
- time-out: from 100 to 3000 ms.

A time-out of between 800 ms and 1000 ms is sufficient in most installations.

Communication via the TCP/IP gateway may, however, be slowed down if other applications want Modbus TCP/IP or IEC 61850 access at the same time.

The time-out value should then be increased (2 to 3 seconds).

- number of retries: from 1 to 6.

Note 1: SFT2841 uses the Modbus TCP/IP communication protocol.

Although communication is IP-based, use of SFT2841 is restricted to a local installation network based on an Ethernet network (LAN – Local Area Network).

The operation of SFT2841 over a WAN (Wide Area Network) cannot be guaranteed because of the presence of some routers or firewalls that may reject the Modbus protocol, causing communication times that would be incompatible with Sepam.

Note 2: SFT2841 allows Sepam protection settings to be modified, and direct activation of the outputs. These operations, which could involve the operation of electrical switchgear (opening and closing), and thus risk the safety of people and installations, are protected by the Sepam password. In addition to this protection, the E-LANs and S-LANs must be designed as private networks, protected from external actions by all suitable methods.

Use

SFT2841 setting and operating software

Configuration of a Sepam network

Use

SFT2841 setting and operating software

Configuration of a Sepam network

SFT2841 setting and operating software

Configuration of a Sepam network

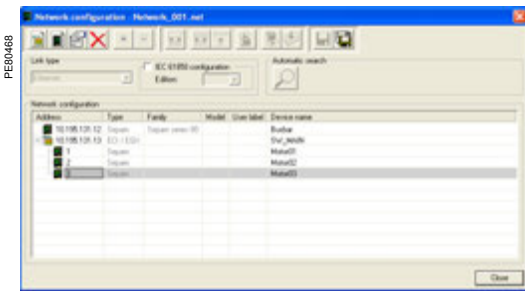

Sepam network connected to SFT2841.

Identification of Sepam units connected to the communication network

The Sepam units connected to the communication network are identified by either.

- their Modbus address
- their IP address
- the IP address for their gateway and their Modbus address

These addresses can be configured in either of the following ways:

- Manually, one by one:
 - the "Add" button is used to define a new device
 - the "Edit" button is used to modify the Modbus address if necessary
 - the "Delete" button removes a device from the configuration
- or automatically for Modbus addresses, by running an automatic search of the Sepam units connected:
 - the "Automatic search"/"Stop search" button starts or interrupts the search
 - when SFT2841 recognizes a Sepam unit, its Modbus address and type are shown on screen
 - when a Modbus device other than Sepam responds to SFT2841, its Modbus address is displayed. The text "???" indicates that the device is not a Sepam.

The Sepam network configuration is saved in a file when the UMI window closes, by pressing the "OK" button.







Access to parameters and settings for a Sepam series 60 connected to a communication network.

Access to Sepam information

To establish communication between SFT2841 and a Sepam network, select the Sepam network configuration you want, select the device connected to the TCP/IP network and press "Connect".

The Sepam network is displayed in the connection window. SFT2841 polls all the equipment defined in the selected configuration. Each Sepam queried is represented by an icon:

-  Sepam series 20 or Sepam series 40 actually connected to the network
-  Easergy Sepam series 60, Sepam series 80 actually connected to the network
-  Sepam configured but not connected to the network
-  Device other than Sepam connected to the network.



A summary report of each Sepam detected as present is also displayed:

- Sepam Modbus address
- Type of application and Sepam identification
- Any alarms present
- Any minor/major faults present.

To access parameters, settings and operation and maintenance information for a particular Sepam, click on the icon for that Sepam. SFT2841 then establishes a point-to-point connection with the selected Sepam.

Basic UMI

This UMI includes:

- 2 signal lamps indicating Sepam operating status:
 - green "on" indicator: device on
 - red  indicator: device unavailable (initialization phase or detection of internal failure)
- 9 parameterizable yellow signal lamps, fitted with a standard label (with SFT2841, a customized label can be printed on a laser printer)
-  key for clearing faults and resetting
- 1 connection port for the link with the PC (CCA783 or CCA784 cord), the connector is protected by a sliding cover.



Fixed or remote advanced UMI

In addition to the basic UMI functions, this version provides:

- a "graphic" LCD display for the display of measurements, parameter/protection settings and alarm and operating messages.

The number of lines, size of characters and symbols are in accordance with the screens and language versions.

The LCD display is back-lit when the user presses a key.



- a 9-key keypad with 2 operating modes:

White keys for current operation:

- ① display of measurements,
- ② display of "switchgear, network diagnosis" data,
- ③ display of alarm messages,
- ④ resetting,
- ⑤ acknowledgment and clearing of alarms.

Blue keys activated in parameter and protection setting mode:

- ⑦ access to protection settings,
- ⑧ access to Sepam parameter setting,
- ⑨ used to enter the 2 passwords required to change protection and parameter settings.

The , ,  (④, ⑤, ⑥) keys are used to browse through the menus and to scroll and accept the values displayed.

- ⑥ "lamp test" key:

switching on sequence of all the signal lamps.

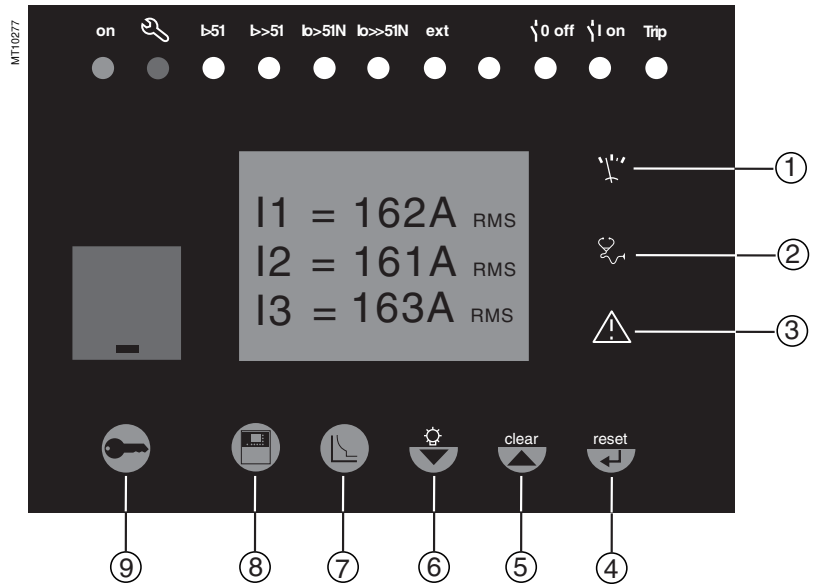

Access to measurements and parameters

The measurements and parameters may be accessed using the metering, diagnosis, status and protection keys. They are arranged in a series of screens as shown in the diagram opposite.

- the data are split up by category in 4 menus, associated with the following 4 keys:
 - key: measurements
choice: current, voltage, frequency, power energy
 - key: switchgear diagnosis and additional measurements
choice: diagnosis, tripping contexts (x5)
 - key: general settings
choice: general, modules, I/U sensors, CT/VT supervision, program logic, I/O test
 - key: protection settings
choice: phase I, residual I, directional I, voltage, frequency, power, machine, recloser
- when the user presses a key, the system moves on to the next screen in the loop. When a screen includes more than 4 lines, the user moves about in the screen via the cursor keys (,).

Example: measurement loop

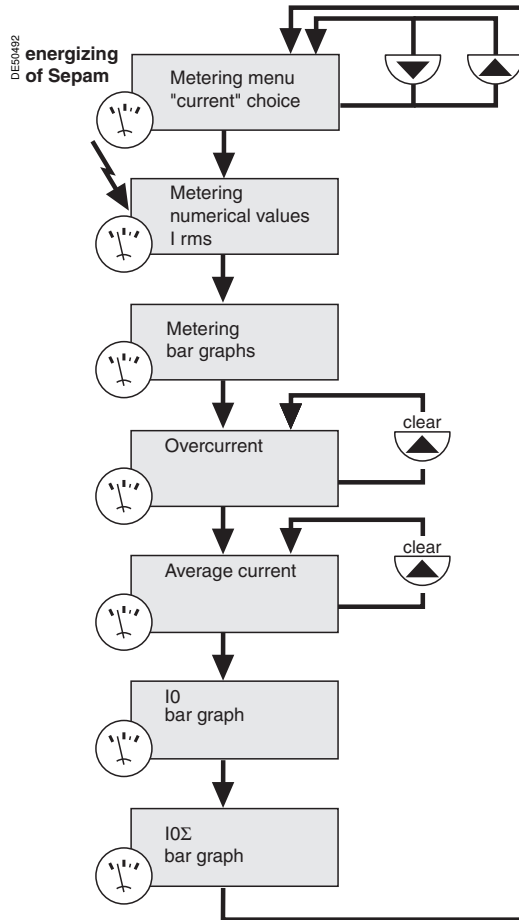

Protection and parameter setting modes

There are 3 levels of use:

- operator level: used to access all the screens in read mode and does not require any passwords
 - protection setter level: requires the entry of the first password (key), allows protection setting (key)
 - parameter setter level: requires the entry of the second password (key), allows modification of the general settings as well (key).
- Only general setters may modify the passwords.
The passwords have 4 digits.

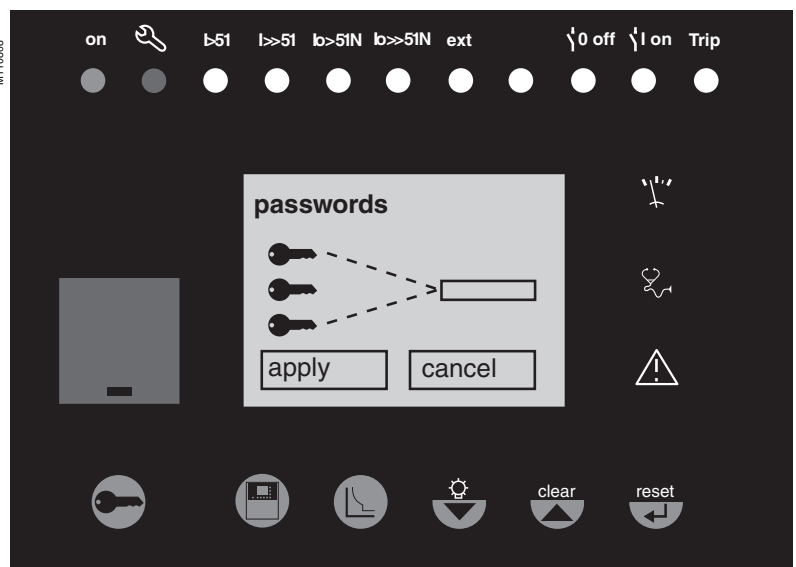

Advanced UMI

White keys for current operation



key

The "metering" key is used to display the variables measured by Sepam.

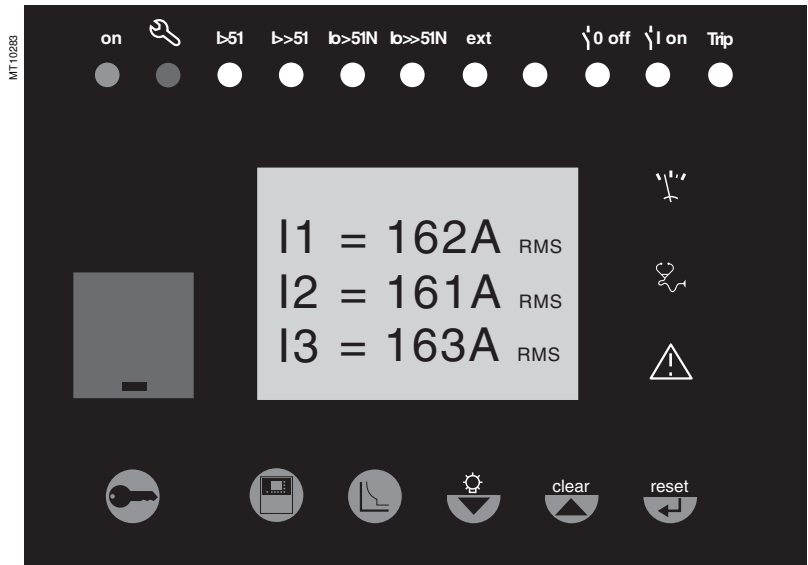

key

The "diagnosis" key provides access to diagnostic data on the breaking device and additional measurements, to facilitate fault analysis.

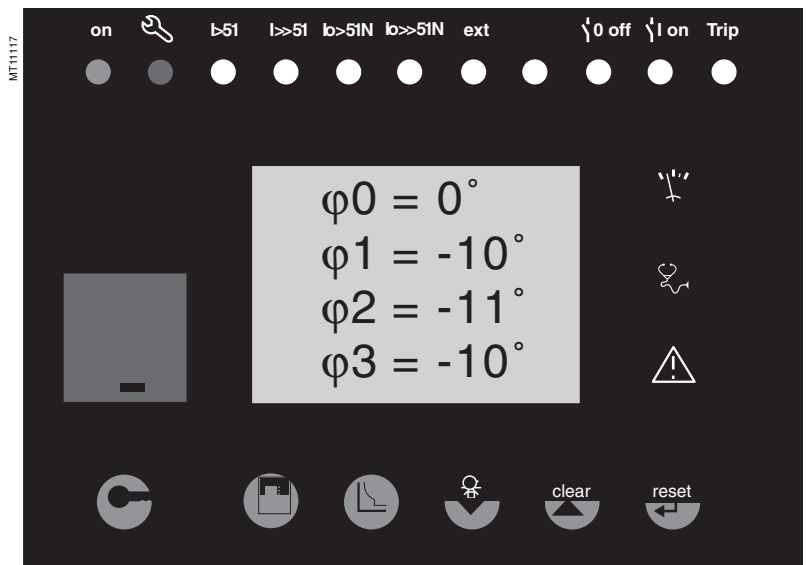

key

The "alarms" key is used to consult the 16 most recent alarms that have not yet been cleared.

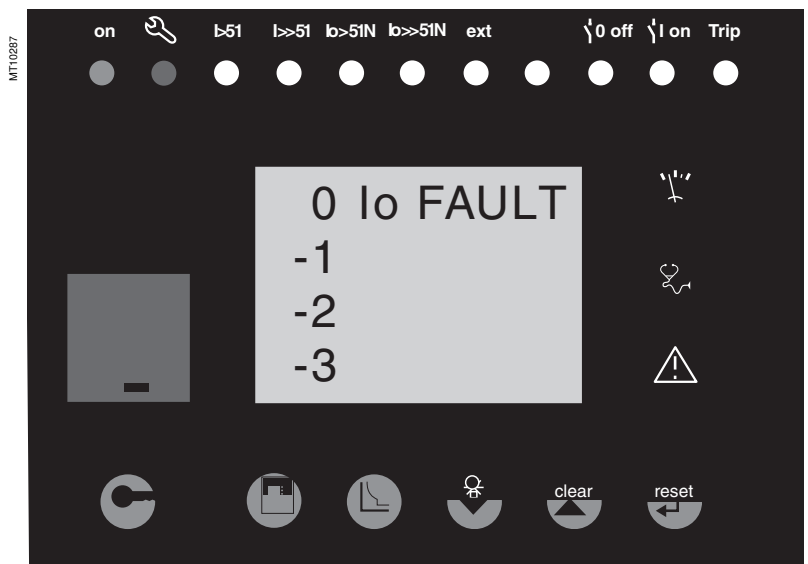

7

Advanced UMI

White keys for current operation



key

The "reset" key resets Sepam (extinction of signal lamps and resetting of protection units after the disappearance of faults).
The alarm messages are not erased.
Sepam resetting must be confirmed.

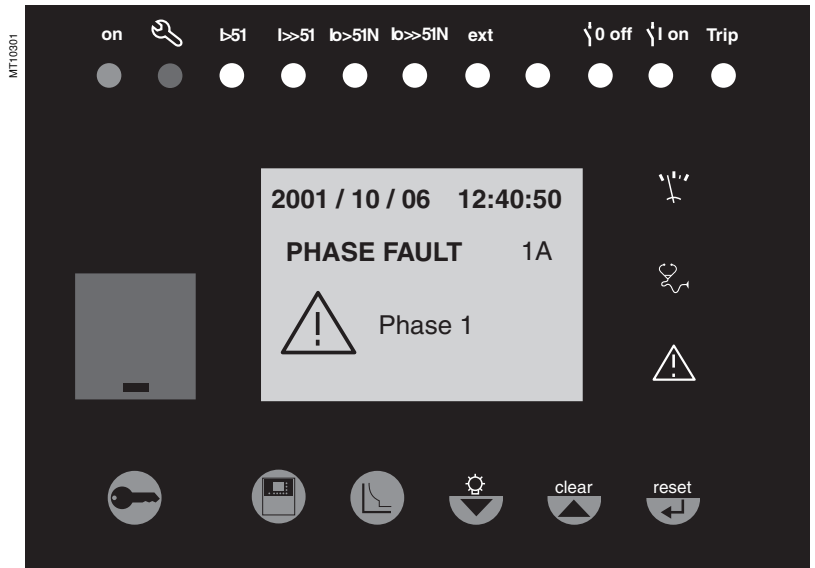

key

When an alarm is present on the Sepam display, the "clear" key is used to return to the screen that was present prior to the appearance of the alarm or to a less recent unacknowledged alarm. Sepam is not reset. In the metering or diagnosis or alarm menus, the "clear" key may be used to reset the average currents, peak demand currents, running hours counter and alarm stack when they are shown on the display.

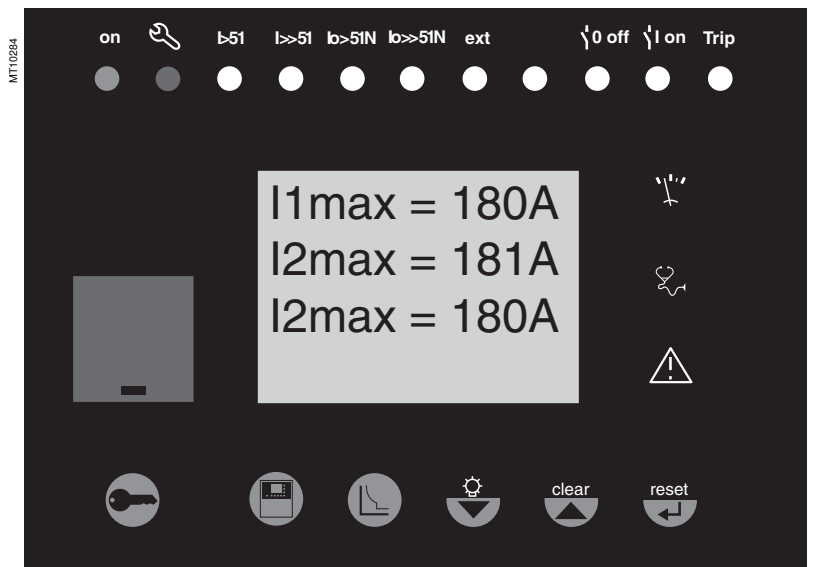

key

Press the "lamp test" key for 5 seconds to start up a LED and display test sequence. When an alarm is present, the "lamp test" key is disabled.

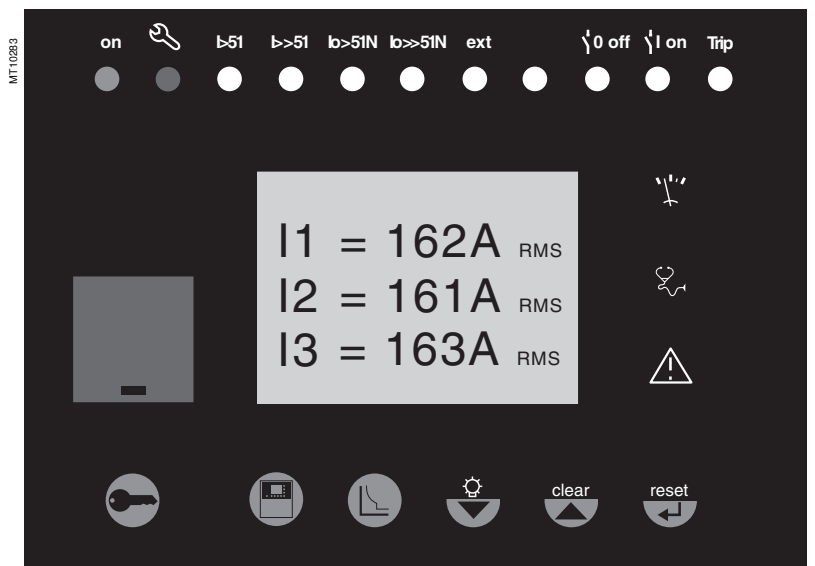

Advanced UMI

Blue keys for parameter and protection setting

key

The "status" key is used to display and enter the Sepam general settings. They define the protected equipment characteristics and the different optional modules. This key can also be used to access the version compatible with SFT2841 screen.

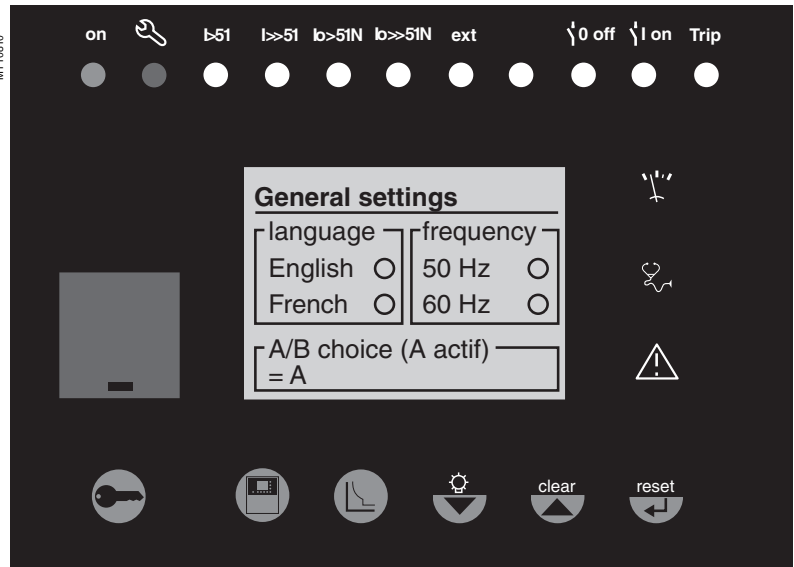

key

The "protection" key is used to display, set and enable or disable the protection units.

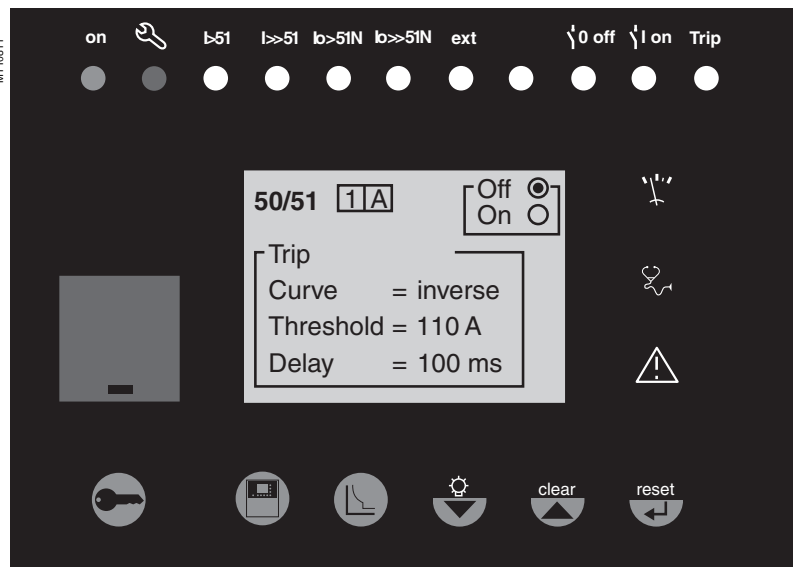

key

The "wrench" key is used to enter the passwords for access to the different modes:

- protection setting
 - parameter setting.
- and return to "operating" mode (with no passwords).

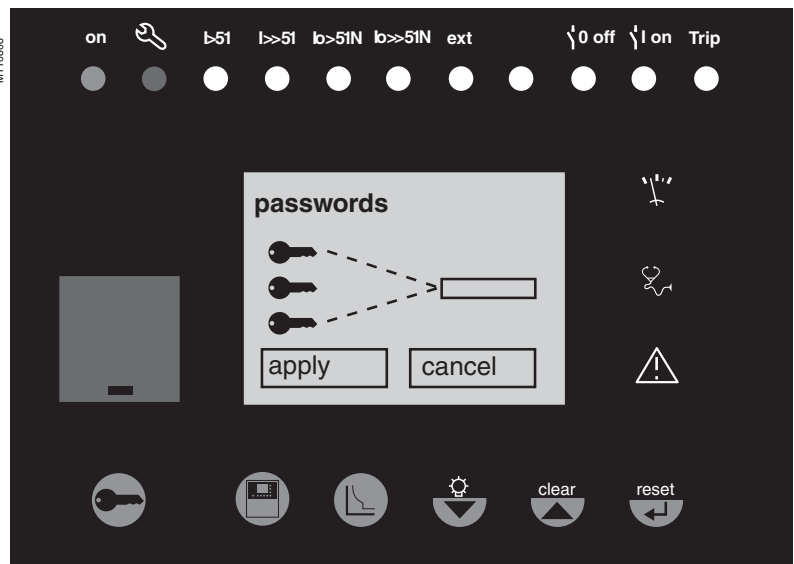

Note: for parameter setting of signal lamps and output relays, it is necessary to use the SFT2841 software, "program logic" menu.

Advanced UMI

Blue keys for parameter and protection setting



key

The  key is used to confirm the protection settings, parameter settings and passwords.

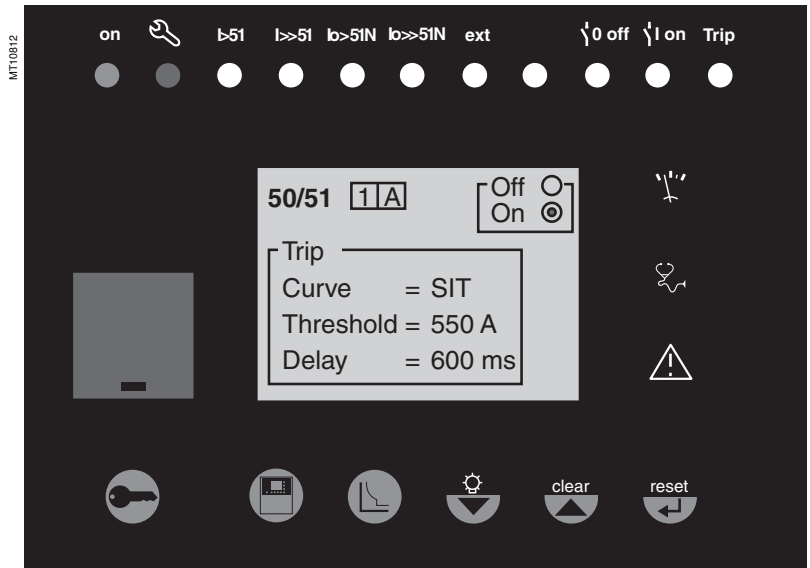

key

When there are no alarms on the Sepam display and the user is in the status, protection or alarm menu, the  key is used to move the cursor upward.

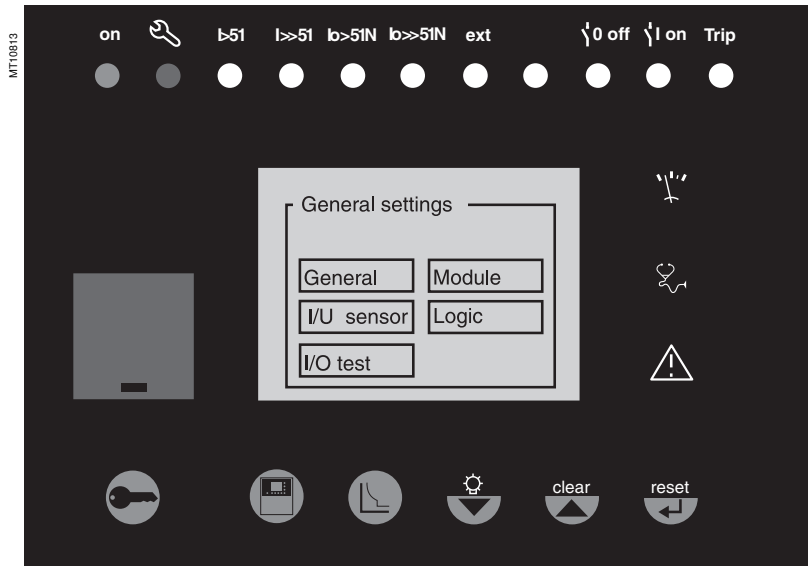

key

When there are no alarms on the Sepam display and the user is in the status, protection or alarm menu, the  key is used to move the cursor downward.

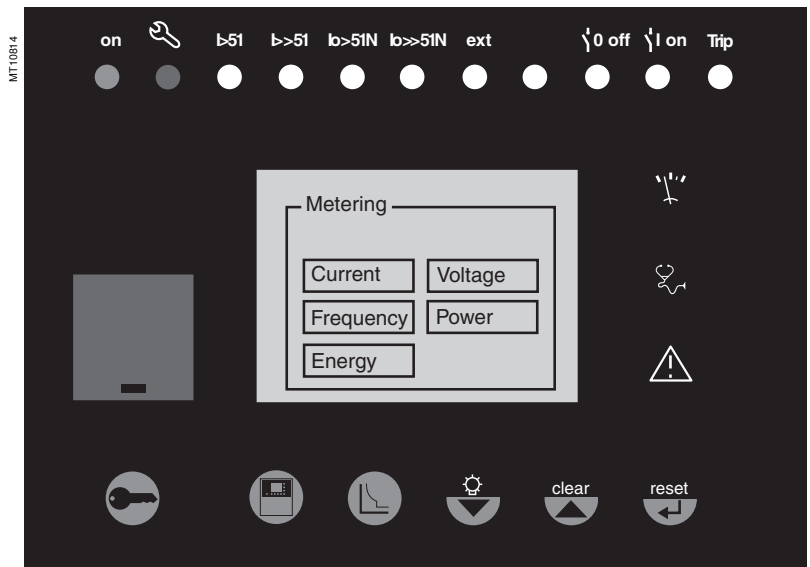

Use of passwords

Sepam has two 4-digit passwords.

- The first password, symbolized by a key, is used to modify the protection settings
- The second password, symbolized by two keys, is used to modify the protection settings and all the general settings.



The 2 factory-set passwords are: 0000

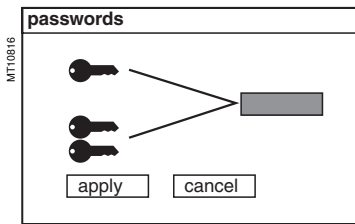

Entry of passwords

Press the  key to display the following screen:



Press the  key to position the cursor on the first digit

Scroll through the digits using the cursor keys (, ) then confirm to go on to the next digit by pressing the  key. Do not use characters other than numbers 0 to 9 for each of the 4 digits.

When the password for your qualification level is entered, press the  key to position the cursor on the box. Press the  key again to confirm.

When Sepam is in protection setting mode, a key appears at the top of the display.

When Sepam is in parameter setting mode, two keys appear at the top of the display.

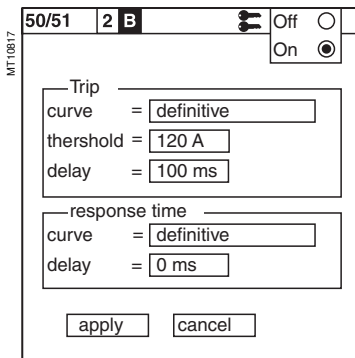

Access to the protection setting or parameter setting modes is disabled:

- By pressing the  key
- Automatically if no keys are activated for more than 5 minutes.

Modification of passwords

Only the parameter setting qualification level (2 keys) or the SFT2841 allow modification of the passwords. Passwords are modified in the general settings screen,  key.









Loss of passwords

If the factory-set passwords have been modified and the latest passwords entered have been irretrievably lost by the user, please contact your local after-sales service representative.

Entry of parameters or settings









Principle applicable to all Sepam screens

(example of phase overcurrent protection)

- Enter the password
- Access the corresponding screen by successively pressing the  key
- Move the cursor by pressing the  key for access to the desired field (e.g. curve)
- Press the  key to confirm the choice, then select the type of curve by pressing the  or  key and confirm by pressing the  key
- Press the  key to reach the following fields, up to the box. Press the  key to confirm the setting.

Entry of numerical values

(e.g. current threshold value)

- Position the cursor on the required field using the   keys, then confirm to go on to the next digit by pressing the  key
- Select the first digit to be entered and set the value by pressing the  or  key (choice of ____: 0.....9)
- Press the  key to confirm the choice and go on to the following digit. The values are entered with 3 significant digits and a period. The unit (e.g. A or kA) is chosen using the last digit.
- Press the  key to confirm the entry, then press the key for access to the following field
- All of the values entered are only effective after the user confirms by selecting the box at the bottom of the screen and presses the  key.

Hardware configuration

- identification: Sepam xxxx
- model: MX
- MES module: absent
- MET modules: absent
- MSA module: absent
- DSM module: present
- ACE module: absent

Output parameter setting

- outputs used: O1 to O4
- shunt trip units: O1, O3
- undervoltage trip units: O2, O4
- impulse mode: no (latched)

Program logic

- circuit breaker control: yes
- logic discrimination: no
- recloser: no
- logic input assignment: not used

General characteristics

- network frequency: 50 Hz
- group of settings: A
- enable remote setting: no
- working language: English
- type of cubicle: feeder (except G40: incomer)
- CT rating: 5 A
- number of CTs: 3 (I1, I2, I3)
- rated current In: 630 A
- basic current Ib: 630 A
- integration period: 5 mn
- residual current: none
- rated primary voltage (Unp): 20 kV
- rated secondary voltage (Uns): 100 V
- voltages measured by VTs: U21, U32
- residual voltage: none
- disturbance recording: 9 x 2-second blocks
- pre-trig for disturbance recording: 36 periods.

Protection functions

- all the protections are "off"
- the settings comprise values and choices that are informative and consistent with the general characteristics by default (in particular rated current and voltage In and Un)
- tripping behavior:
 - latching: 50/51, 50V/51V, 50N/51N, 67, 67N, 46, 46BC, 32P, 32Q/40, 48/51LR/14, 27D, 38/49T, 49RMS
 - participation in circuit breaker control: 50/51, 50V/51V, 50N/51N, 67, 67N, 46, 46BC, 32P, 32Q/40, 48/51LR/14, 27D, 49RMS, 38/49T, 37
 - disturbance recording triggering: with.

Control matrix

- activation of signal lamps according to front panel markings
- watchdog on output O4
- disturbance recording triggering upon activation of pick up signal.

DANGER

HAZARD OF ELECTRIC SHOCK, ELECTRIC ARC OR BURNS

- Only qualified personnel should commission this equipment. Such work should be performed only after reading this entire set of instructions.
- NEVER work alone.
- Obey all existing safety instructions when commissioning and maintaining high-voltage equipment.
- Beware of potential hazards and wear personal protective equipment.

Failure to follow these instructions will result in death or serious injury.

Protection relay testing

Protection relays are tested prior to commissioning, with the dual aim of maximizing availability and minimizing the risk of malfunctioning of the assembly being commissioned. The problem consists of defining the consistency of the appropriate tests, keeping in mind that the relay is always involved as the main link in the protection chain.

Therefore, protection relays based on electromechanical and static technologies, the performances of which are not totally reproducible, must be systematically submitted to detailed testing, not only to qualify relay commissioning, but also to check that they actually are in good operating order and maintain the required level of performance.

The Sepam concept makes it possible to do away with such testing, since:

- the use of digital technology guarantees the reproducibility of the performances announced
- each of the Sepam functions has undergone full factory-qualification
- an internal self-testing system provides continuous information on the state of the electronic components and the integrity of the functions (e.g. automatic tests diagnose the level of component polarization voltages, the continuity of the analog value acquisition chain, non-alteration of RAM memory, absence of settings outside the tolerance range) and thereby guarantees a high level of availability

Sepam is therefore ready to operate without requiring any additional qualification testing that concerns it directly.

Sepam commissioning tests

The preliminary Sepam commissioning tests may be limited to a commissioning check, i.e.:

- checking of compliance with BOMs and hardware installation diagrams and rules during a preliminary general check
 - checking of the compliance of the general settings and protection settings entered with the setting sheets
 - checking of current or voltage input connection by secondary injection tests
 - checking of logic input and output connection by simulation of input data and forcing of output status
 - validation of the complete protection chain (possible customized logic functions included)
 - checking of the connection of the optional MET148-2 and MSA141 modules.
- The various checks are described further on.

General principles

- **all the tests should be carried out with the MV cubicle completely isolated and the MV circuit breaker racked out (disconnected and open)**
- **all the tests are to be performed in the operating situation: no wiring or setting changes, even temporary changes to facilitate testing, are allowed.**
- the SFT2841 parameter setting and operating software is the basic tool for all Sepam users. It is especially useful during Sepam commissioning tests. The tests described in this document are systematically based on the use of that tool.

Method

For each Sepam:

- only carry out the checks suited to the hardware configuration and the functions activated
- (A comprehensive description of all the tests is given further on)
- use the test sheet provided to record the results of the commissioning tests.

Checking of current and voltage input connections

The secondary injection tests to be carried out to check the connection of the current and voltage inputs are described according to:

- the type of current and voltage sensors connected to Sepam, in particular for residual current and voltage measurement
- the type of injection generator used for the tests: three-phase or single-phase generator.

The different possible tests are described further on by:

- a detailed test procedure
- the connection diagram of the associated test generator.

The table below specifies the tests to be carried out according to the type of measurement sensors and type of generator used, and indicates the page on which each test is described.

Current sensors	3 CTs	3 CTs + 1 core balance CT	3 CTs	3 CTs + 1 core balance CT
Voltage sensors	3 VTs	3 VTs	2 phase VTs + 1 residual VT	2 phase VTs + 1 residual VT
Three-phase generator	Page 290	Page 290 Page 295	Page 291 Page 296	Page 291 Page 297
Single-phase generator	Page 292	Page 292 Page 295	Page 292 Page 296	Page 292 Page 297



Generators

- dual sinusoidal AC current and voltage generator:
 - 50 or 60 Hz frequency (according to the country)
 - current adjustable up to at least 5 Arms
 - adjustable up to the rated secondary phase-to-phase voltage of the VTs
 - adjustable relative phase displacement (V, I)
 - three-phase or single-phase type
- DC voltage generator:
 - adjustable from 48 to 250 V DC, for adaptation to the voltage level of the logic input being tested.

Accessories

- plug with cord to match the "current" test terminal box installed
- plug with cord to match the "voltage" test terminal box installed
- electric cord with clamps, wire grip or touch probes.

Metering devices (built into the generator or separate)

- 1 ammeter, 0 to 5 A rms
- 1 voltmeter, 0 to 230 V rms
- 1 phasemeter (if phase displacement (V, I) is not identified on the voltage and current generator).

Computer equipment

- PC with minimal configuration:
 - Microsoft Windows XP or Vista
 - 400 MHz Pentium processor,
 - 64 MB of RAM
 - 200 MB free on hard disk
 - CD-ROM drive
- SFT2841 software
- CCA783 serial connection or CCA784 USB cord between the PC and Sepam.

Documents

- complete connection diagram of Sepam and additional modules, with:
 - phase current input connection to the corresponding CTs via the test terminal box
 - residual current input connection
 - phase voltage input connection to the corresponding VTs via the test terminal box
 - residual voltage input connection to the corresponding VTs via the test terminal box
 - logic input and output connection
 - temperature sensor connection
 - analog output connection
- hardware BOMs and installation rules
- group of Sepam parameter and protection settings, available in paper format.

Checking to be done prior to energizing

Apart from the mechanical state of the equipment, use the diagrams and BOMs provided by the contractor to check:

- identification of Sepam and accessories determined by the contractor
- correct earthing of Sepam (via terminal 17 of the 20-pin connector)
- correct connection of auxiliary voltage (terminal 1: AC or positive polarity; terminal 2: AC or negative polarity)
- presence of a residual current measurement core balance CT and/or additional modules connected to Sepam, when applicable
- presence of test terminal boxes upstream from the current inputs and voltage inputs
- conformity of connections between Sepam terminals and the test terminal boxes.

Connections

Check that the connections are tightened (with equipment non-energized). The Sepam connectors must be correctly plugged in and locked.

Energizing

1. Switch on the auxiliary power supply.
 2. Check that Sepam performs the following initialization sequence, which lasts approximately 6 seconds:
 - green ON and red indicators on
 - red indicator off
 - pick-up of "watchdog" contact.
- The first screen displayed is the phase current measurement screen.

Implementation of the SFT2841 software for PC

1. Start up the PC.
2. Connect the PC RS232 serial or USB port to the communication port on the front panel of Sepam using the CCA783 or CCA784 cord.
3. Start up the SFT2841 software, by clicking on the related icon.
4. Choose to connect to the Sepam to be checked.

Identification of Sepam

1. Note the Sepam serial number given on the label stuck to the right side plate of the base unit
2. Note the Sepam type and software version using the SFT2841 software, "Sepam Diagnosis" screen
3. Enter them in the test sheet.

Determination of parameter and protection settings

All of the Sepam parameter and protection settings are determined beforehand by the design department in charge of the application, and should be approved by the customer.

It is presumed that the study has been carried out with all the attention necessary, or even consolidated by a network coordination study.

All of the Sepam parameter and protection settings should be available at the time of commissioning:

- in hard copy format (with the SFT2841 software, the parameter and protection setting file for a Sepam can be printed directly or exported to a text file for editing)
- and, when applicable, in the format of a file to be downloaded into Sepam using the SFT2841 software.

Checking parameters and protection settings

Check to be made when the Sepam parameter and protection settings have not been entered or downloaded during commissioning testing, to confirm the conformity of the parameter and protection settings entered with the values determined during the study.

The aim of this check is not to confirm the relevance of the parameter and protection settings.

1. Go through all the parameter and protection setting screens in the SFT2841 software, in the order proposed in guided mode.
2. For each screen, compare the values entered in the Sepam with the values recorded in the parameter and protection setting file.
3. Correct any parameter and protection settings that have not been entered correctly, proceeding as indicated in the "Use of the (SFT2841) software" section of this manual.

Conclusion

Once the checking has been done and proven to be conclusive, as of that phase, the parameter and protection settings should not be changed any further and are considered to be final.

In order to be conclusive, the tests which follow must be performed with these parameter and protection settings. We strongly recommend that you do not modify, even temporarily, any of the existing values to facilitate testing.

Checking of phase current and voltage input connection With 3-phase generator

Procedure

1. Connect the 3-phase voltage and current generator to the corresponding test terminal boxes, using the plugs provided, according to the appropriate diagram in terms of the number of VTs connected to Sepam:

- block diagram with 3 VTs connected to Sepam

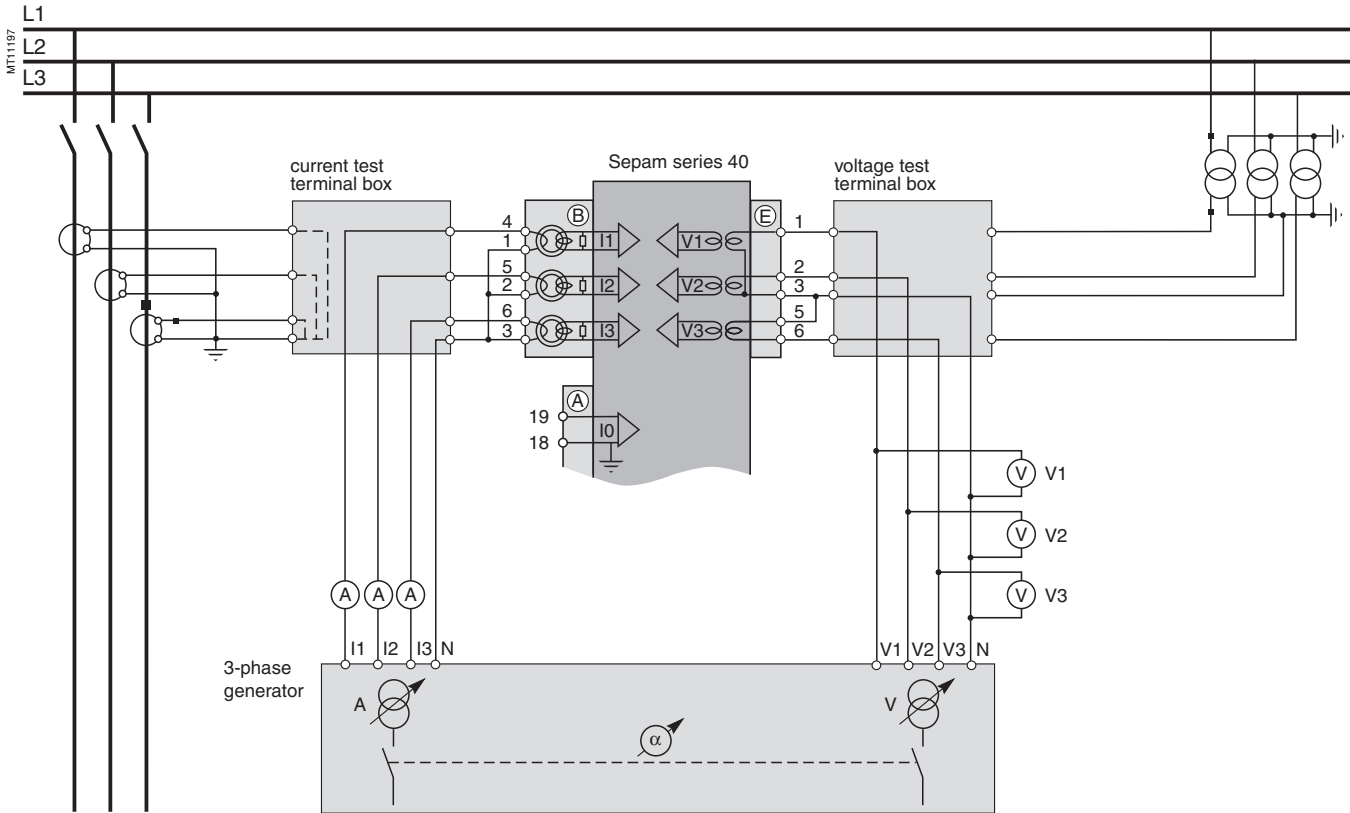

Checking of phase current and voltage input connection With 3-phase generator

■ block diagram with 2 VTs connected to Sepam.

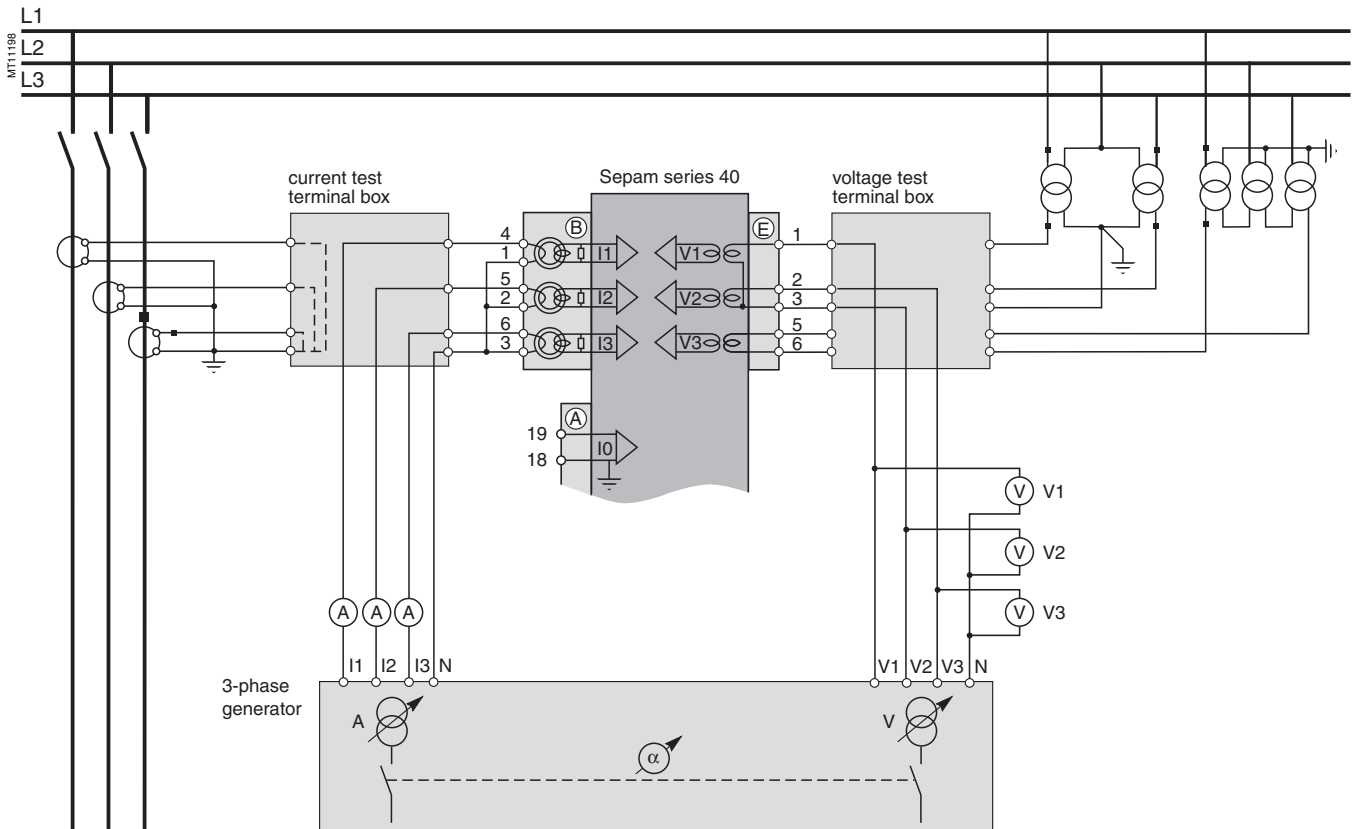

2. Turn the generator on.
3. Apply the 3 generator voltages V1-N, V2-N and V3-N, balanced and set to the rated secondary phase-to-neutral voltage of the VTs (i.e. $V_{ns} = U_{ns}/\sqrt{3}$).
4. Inject the 3 generator currents I1, I2 and I3, balanced and set to the rated secondary current of the CTs (i.e. 1 A or 5 A) and in phase with the voltages applied (i.e. generator phase displacement: $\alpha_1(V1-N, I1) = \alpha_2(V2-N, I2) = \alpha_3(V3-N, I3) = 0^\circ$).
5. Use the SFT2841 software to check the following:
 - the value indicated for each of the phase currents I1, I2 and I3 is approximately equal to the rated primary current of the CTs
 - the value indicated for each of the phase-to-neutral voltages V1, V2 and V3 is approximately equal to the rated primary phase-to-neutral voltage of the VT ($V_{np} = U_{np}/\sqrt{3}$)
 - the value indicated for each phase displacement $\phi_1(V1, I1)$, $\phi_2(V2, I2)$ and $\phi_3(V3, I3)$ between currents I1, I2 or I3 and voltages V1, V2 or V3 respectively is approximately equal to 0° .
6. Turn the generator off.

Checking of phase current and voltage input connection

With single-phase generator and voltages delivered by 3 VTs

Procedure

1. Connect the single-phase voltage and current generator to the corresponding test terminal boxes, using the plugs provided, according to the block diagram below:

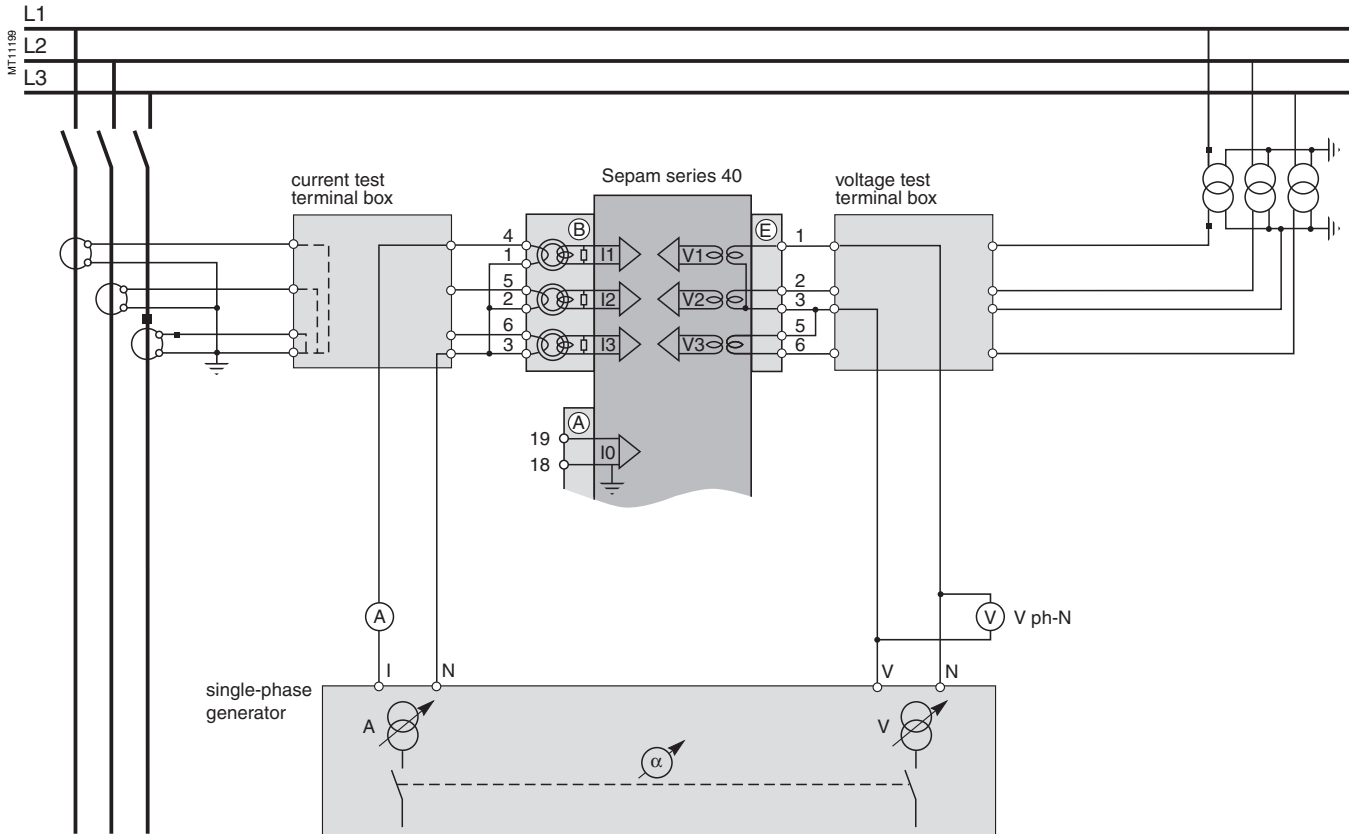

2. Turn the generator on.
3. Apply the generator V-N voltage set to the rated secondary phase-to-neutral voltage of the VTs (i.e. $V_{ns} = U_{ns}/\sqrt{3}$) between Sepam's phase 1 voltage input terminals (via the test box).
4. Inject the generator I current, set to the rated secondary current of the CTs (i.e. 1 A or 5 A) and in phase with the V-N voltage applied (i.e. generator phase displacement $\alpha(V-N, I) = 0^\circ$) to Sepam's phase 1 current input (via the test box).
5. Use the SFT2841 software to check the following:
 - the value indicated for I1 phase current is approximately equal to the rated primary current of the CT
 - the value indicated for V1 phase-to-neutral voltage is approximately equal to the rated primary phase-to-neutral voltage of the VT ($V_{np} = U_{np}/\sqrt{3}$)
 - the value indicated for the phase displacement $\phi_1(V1, I1)$ between the I1 current and V1 voltage is approximately equal to 0° .
6. Proceed in the same way by circular permutation with the phase 2 and 3 voltages and currents, to check the I2, V2, $\phi_2(V2, I2)$ and I3, V3, $\phi_3(V3, I3)$ values.
7. Turn the generator off.

Checking of phase current and voltage input connection

With single-phase generator and voltages delivered by 2 VTs

Description

Check to be carried out when the voltages are supplied by a 2 VT assembly, with the VT primary circuits connected between phases of the distributed voltage, which means that the residual voltage is obtained outside Sepam (by 3 VTs connected via their secondary circuits in an open delta arrangement) or, when applicable, is not used for the protection function.

Procedure

1. Connect the single-phase voltage and current generator to the corresponding test terminal boxes, using the plugs provided, according to the block diagram below:

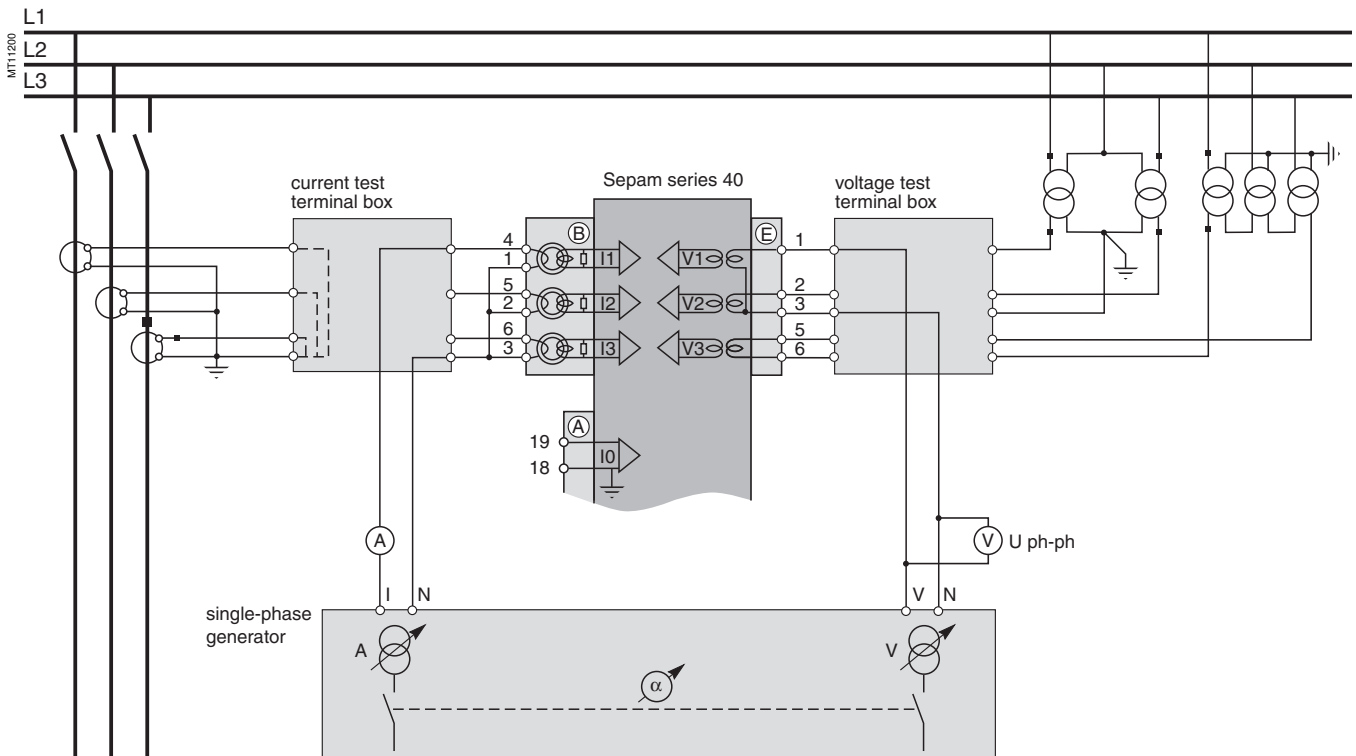

2. Turn the generator on.
3. Apply (via the test box) the voltage delivered at the V-N terminals of the generator, set to $\sqrt{3}/2$ times the rated secondary phase-to-phase voltage of the VTs (i.e. $\sqrt{3}$ Uns/2) between terminals 1-3 of Sepam's voltage inputs.
4. Inject the generator I current, set to the rated secondary current of the CTs (i.e. 1 A or 5 A) and in phase with the V-N voltage applied (i.e. generator phase displacement $\alpha(V-N, I) = 0^\circ$) to Sepam's phase 1 current input (via the test box).
5. Use the SFT2841 software to check the following:
 - the value indicated for I1 phase current is approximately equal to the rated primary current of the CT (I_{np})
 - the value indicated for V1 phase-to-neutral voltage is approximately equal to the rated primary phase-to-neutral voltage of the VT ($V_{np} = U_{np}/\sqrt{3}$)
 - the value indicated for the phase displacement $\phi_1(V1, I1)$ between the I1 current and V1 voltage is approximately equal to 0° .
6. Proceed in the same way to check the I2, V2, $\phi_2(V2, I2)$ values:
 - apply the generator V-N voltage set to $\sqrt{3}$ Uns/2 in parallel between terminals 1-3 and 2-3 of Sepam's voltage inputs (via the test box)
 - inject an I current set to 1 A or 5 A and in phase opposition with the V-N voltage (i.e. $\alpha(V-N, I) = 180^\circ$) to Sepam's phase 2 current input (via the test box)
 - obtain $I2 \cong I_{np}$, $V2 \cong V_{np} = U_{np}/\sqrt{3}$ and $\phi_2 \cong 0^\circ$.
7. Check the I3, V3, $\phi_3(V3, I3)$ values as well:
 - apply the generator V-N voltage set to $\sqrt{3}$ Uns/2 between terminals 2-3 of Sepam's voltage inputs (via the test box)
 - inject a current equal to 1 A or 5 A and in phase with the V-N voltage (i.e. $\alpha(V-N, I) = 0^\circ$) to Sepam's phase 3 current input (via the test box)
 - obtain $I3 \cong I_{np}$, $V3 \cong V_{np} = U_{np}/\sqrt{3}$ and $\phi_3 \cong 0^\circ$.
8. Turn the generator off.

Checking of phase current and voltage input connection LPCT type current sensors

Description

Check to be performed when phase currents are measured by LPCT-type current sensors.

Phase current measurement by LPCT sensors

- The 3 LPCT current sensors are connected via an RJ45 plug to the CCA670 connector which is to be mounted on the rear panel of Sepam, identified as (B)
- The connection of only one or two LPCT sensors is not allowed and causes Sepam to go into the fail-safe position
- The rated primary current I_n measured by the LPCT sensors is to be entered as a Sepam general setting and configured by microswitches on the CCA670 connector.

Procedure

The tests to be carried out to check phase current input connections are the same whether the phase currents are measured by CTs or LPCT sensors. Only the Sepam current input connection procedure and current injection values change.

To test current inputs connected to LPCT sensors with a standard injection box, the ACE917 injection adapter is required.

The ACE917 adapter is inserted between:

- the standard injection box
- the LPCT test plug:
 - integrated in the Sepam CCA670 connector
 - or transferred by means of the CCA613 accessory.

The ACE917 injection adapter should be set according to the currents selected on the CCA670 connector: the ACE917 setting should be equal to the number of the microswitch that is set to 1 on the CCA670.

The injection value depends on the rated primary current selected on the CCA670 connector and entered in the Sepam general settings, i.e.:

- 1 A for the following values (in Amps): 25, 50, 100, 133, 200, 320, 400, 630
- 5 A for the following values (in Amps): 125, 250, 500, 666, 1000, 1600, 2000, 3150.

Block diagram (without CCA613 accessory)

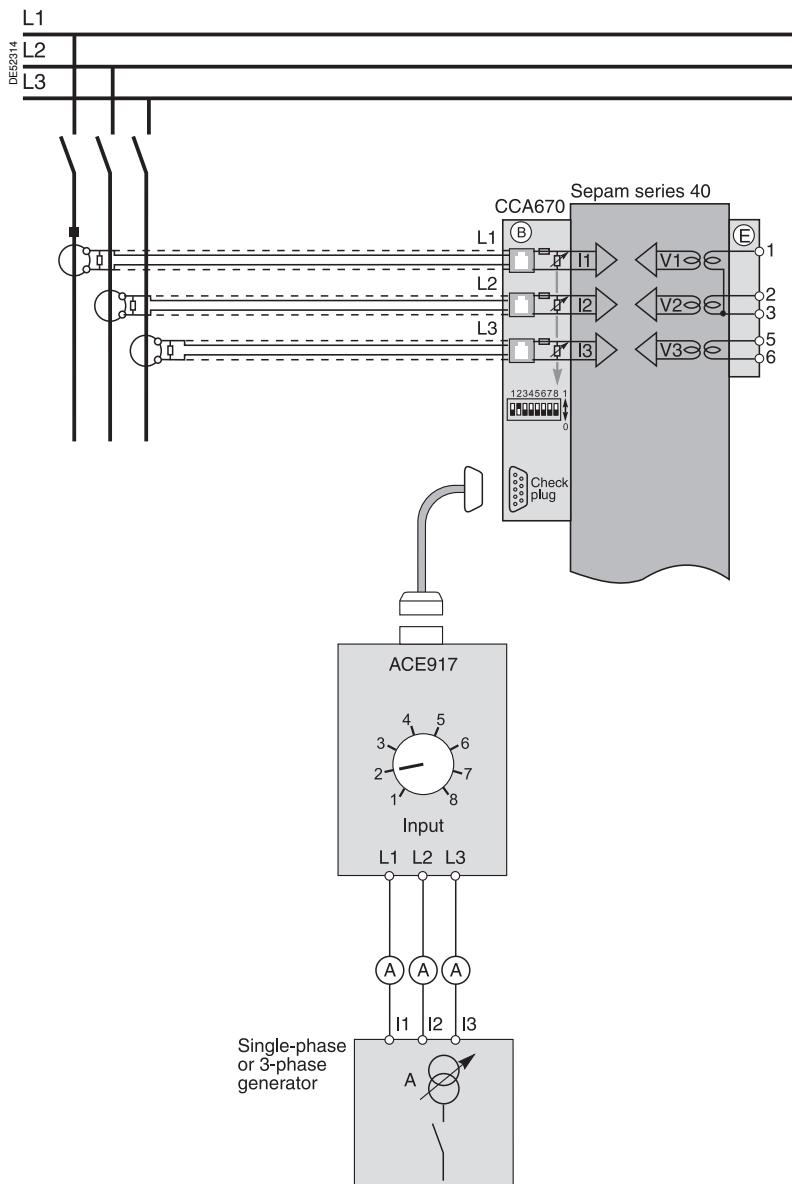

Description

Check to be carried out when the residual current is measured by a specific sensor such as:

- CSH120, CSH200 or CSH300 core balance CT
 - CSH30 interposing ring CT (whether it is installed on the secondary circuit of a single 1 A or 5 A CT which encompasses the 3 phases, or on the neutral connection of the three 1 A or 5 A phase CTs)
 - other core balance CT connected to an ACE990 interface,
- and when the residual voltage is calculated in Sepam or cannot be calculated (and is therefore not available for the protection function).

Procedure

1. Connect according to the diagram below:

- a wire between the generator current terminals to inject current into the primary circuit of the core balance CT or CT, with the wire passing through the core balance CT or CT in the P1-P2 direction, with P1 the busbar end and P2 the cable end
- when applicable, the generator voltage terminals to the voltage test terminal box, so as to only supply Sepam's phase 1 voltage input and therefore obtain a residual voltage $V_0 = V_1$.

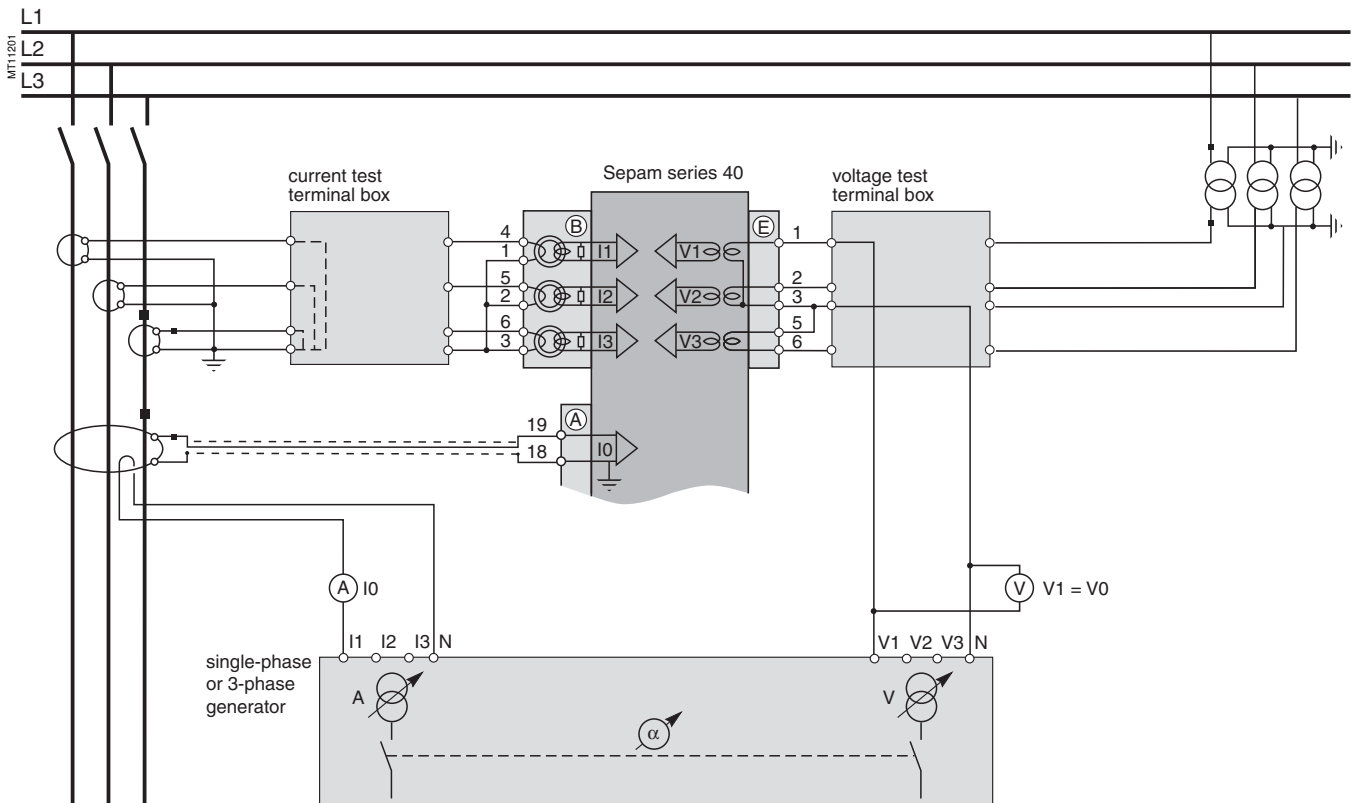

2. Turn the generator on.
3. When applicable, apply a V-N voltage set to the rated secondary phase-to-neutral voltage of the VT (i.e. $V_{ns} = U_{ns}/\sqrt{3}$).
4. Inject an I current set to 5 A, and when applicable in phase with the V-N voltage applied (i.e. generator phase displacement $\alpha(V-N, I) = 0^\circ$).
5. Use the SFT2841 software to check the following:
 - the value indicated for the measured I_0 residual current is approximately equal to 5 A
 - when applicable, the value indicated for calculated V_0 residual voltage is approximately equal to the rated primary phase-to-neutral voltage of the VTs (i.e. $V_{np} = U_{np}/\sqrt{3}$)
 - when applicable, the value indicated for the phase displacement $\phi_0(V_0, I_0)$ between the I_0 current and V_0 voltage is approximately equal to 0° .
6. Turn the generator off.

Description

Check to be carried out when the residual voltage is delivered by 3 VTs on the secondary circuits connected in an open delta assembly, and when the residual current is calculated in Sepam or, when applicable, is not used for the protection function.

Procedure

1. Connect according to the diagram below:

- the generator voltage terminals to the voltage test terminal box, so as to only supply Sepam's residual voltage input
- when applicable, the generator current terminals to the current test terminal box, so as to only supply Sepam's phase 1 current input, and therefore obtain a residual current $I_{0\Sigma} = I_1$.

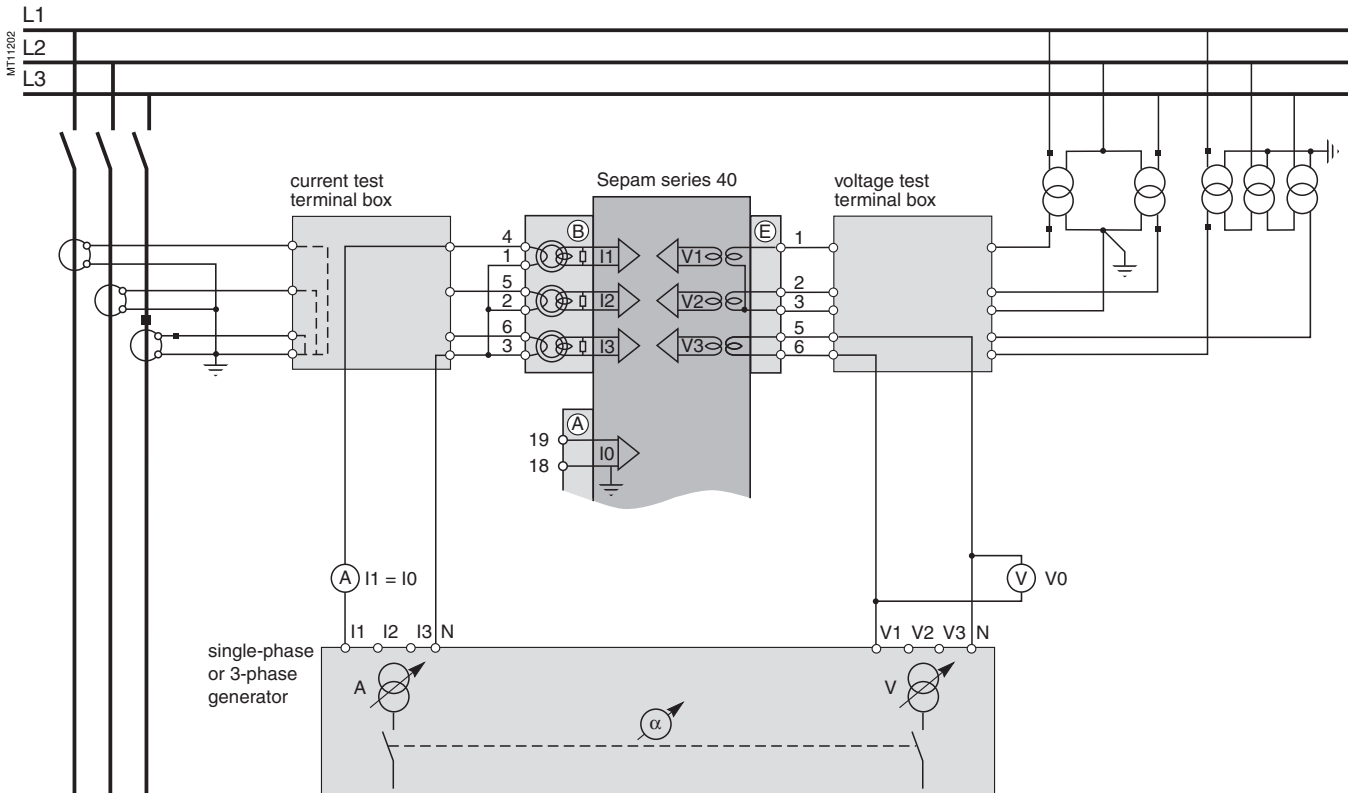

2. Turn the generator on.

3. Apply a V-N voltage set to the rated secondary voltage of the VTs installed in an open delta arrangement (i.e., depending on the case, $U_{ns}/\sqrt{3}$ or $U_{ns}/3$).

4. When applicable, inject an I current set to the rated secondary current of the CTs (i.e. 1 A or 5 A) and in phase with the voltage applied (i.e. generator phase displacement $\alpha(V-N, I) = 0^\circ$).

5. Use the SFT2841 software to check the following:

- the value indicated for the measured V_0 residual voltage is approximately equal to the rated primary phase-to-neutral voltage of the VTs (i.e. $V_{np} = U_{np}/\sqrt{3}$)

- when applicable, the value indicated for the calculated $I_{0\Sigma}$ residual current is approximately equal to the rated primary current of the CTs

- when applicable, the value indicated for the phase displacement $\varphi_{0\Sigma}$ ($V_0, I_{0\Sigma}$) between the $I_{0\Sigma}$ current and V_0 voltage is approximately equal to 0° .

6. Turn the generator off.

Description

Check to be carried out when the residual voltage is delivered by 3 VTs on the secondary circuits connected in an open delta assembly and when the residual current is obtained by a specific sensor such as:

- CSH120, CSH200 or CSH300 core balance CT
- CSH30 interposing ring CT (whether it is installed on the secondary circuit of a single 1 A or 5 A CT which encompasses the 3 phases, or on the neutral connection of the three 1 A or 5 A phase CTs)
- other core balance CT connected to an ACE990 interface.

Procedure

1. Connect according to the diagram below:
 - the generator voltage terminals to the voltage test terminal box using the plug provided,
 - a wire between the generator current terminals to inject current into the primary circuit of the core balance CT or CT, with the wire passing through the core balance CT or CT in the P1-P2 direction, with P1 the busbar end and P2 the cable end.

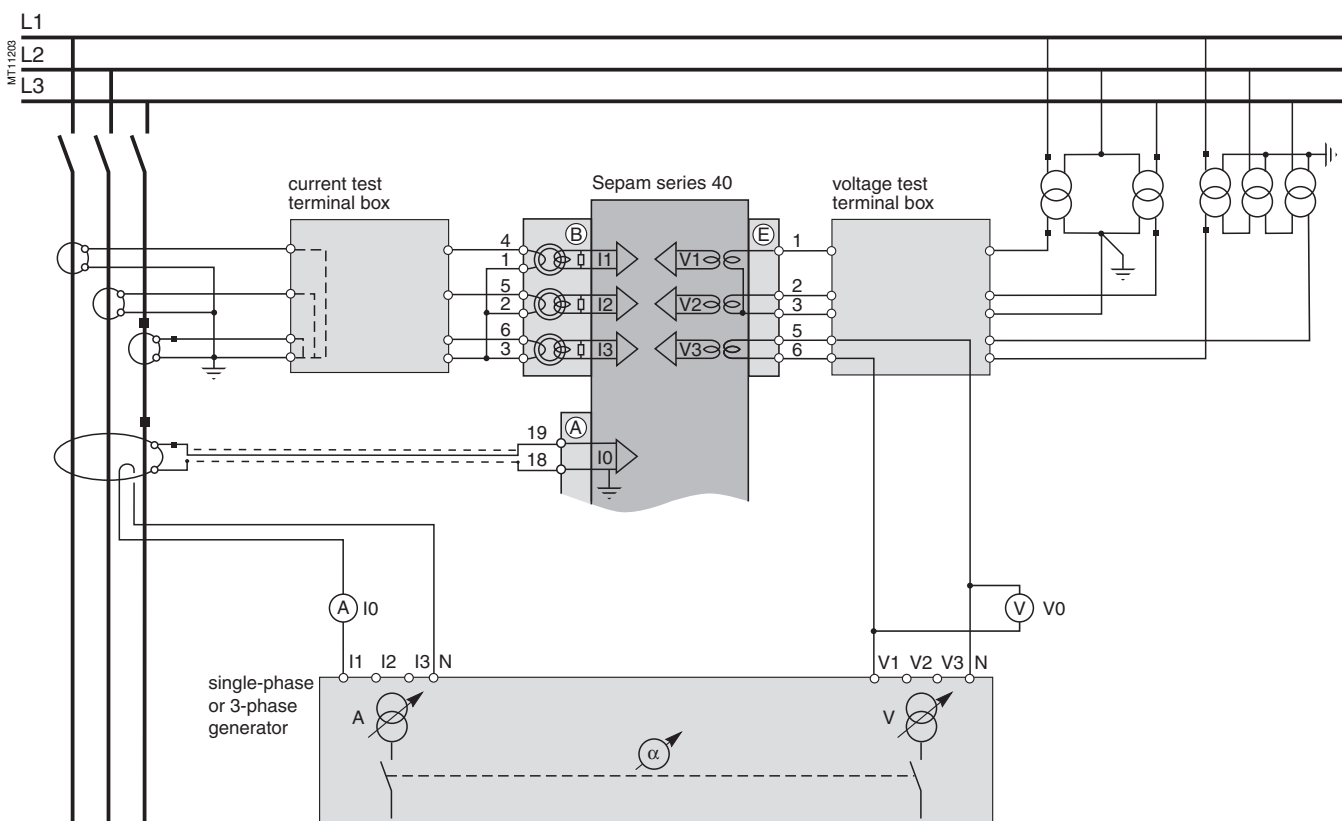

2. Turn the generator on.
3. Apply a V-N voltage set to the rated secondary voltage of the VTs connected in an open delta arrangement (i.e. $U_{ns}/\sqrt{3}$ or $U_{ns}/3$).
4. Inject an I current set to 5 A, and in phase with the voltage applied (i.e. generator phase displacement $\alpha(V-N, I) = 0^\circ$).
5. Use the SFT2841 software to check the following:
 - the value indicated for the measured I0 residual current is approximately equal to 5 A
 - the value indicated for the measured V0 residual voltage is approximately equal to the rated primary phase-to-neutral voltage of the VTs (i.e. $V_{np} = U_{np}/\sqrt{3}$)
 - the value indicated for the phase displacement $\varphi_0(V_0, I_0)$ between the I0 current and V0 voltage is approximately equal to 0° .
6. Turn the generator off.



"Input, output, indicator status" screen.

Checking of logic input connection

Procedure

Proceed as follows for each input:

1. **If the input supply voltage is present**, use an electric cord to short-circuit the contact that delivers logic data to the input.
2. **If the input supply voltage is not present**, apply a voltage supplied by the DC voltage generator to the terminal of the contact linked to the chosen input, being sure to comply with the suitable polarity and level.
3. **Observe the change of status of the input** using the SFT2841 software, in the "Input, output, indicator status" screen.
4. At the end of the test, if necessary, press the SFT2841 Reset key to clear all messages and deactivate all outputs.

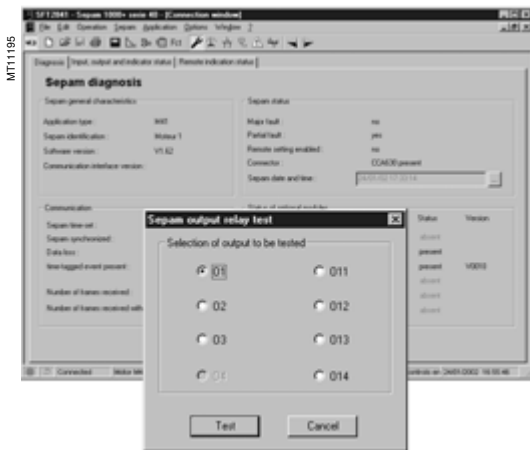

"Sepam diagnosis and output relay test" screen.

Checking of logic output connection

Procedure

Check carried out using the "Output relay test" function, activated via the SFT2841 software, in the "Sepam Diagnosis" screen.

Only output O4, when used for the watchdog, can be tested.

This function requires prior entry of the "Parameter setting" password.

1. Activate each output relay using the buttons in the SFT2841 software.
2. The activated output relay changes status over a period of 5 seconds.
3. Observe the change of status of the output relay through the operation of the related switchgear (if it is ready to operate and is powered), or connect a voltmeter to the terminals of the output contact (the voltage cancels itself out when the contact closes).
4. At the end of the test, press the SFT2841 Reset key to clear all messages and deactivate all outputs.

Validation of the complete protection chain

Checking of optional modules connection

Validation of the complete protection chain

Principle

The complete protection chain is validated during the simulation of a fault that causes tripping of the breaking device by Sepam.

Procedure

1. Select one of the protection functions that triggers tripping of the breaking device and separately, according to their incidence in the chain, the function or functions related to the programmed or reprogrammed parts of the program logic.
2. According to the selected function or functions, inject a current and/or apply a voltage that corresponds to a fault.
3. Observe the tripping of the breaking device and the operation of the adapted parts of the program logic.

At the end of all the voltage and current application type checks, put the covers back on the test terminal boxes.

Checking of optional module connection

Checking of RTD inputs to the MET148-2 module

The temperature monitoring function provided by Sepam T40, T42, T50, T52, M40, M41 and G40 units checks the connection of each RTD that is configured.

An "RTD FAULT" alarm is generated whenever one of the RTDs is detected as being short-circuited or disconnected (absent).

To identify the faulty RTD or RTDs:

1. Display the temperature values measured by Sepam using the SFT2841 software.
2. Check the consistency of the temperatures measured:
 - the temperature displayed is "*****" if the RTD is short-circuited ($T < -35\text{ °C}$)
 - the temperature displayed is "-*****" if the RTD is disconnected ($T > 205\text{ °C}$).

Checking of analog output connection to the MSA141 module

1. Identify the measurement associated by parameter setting to the analog output using the SFT2841 software.
2. Simulate, if necessary, the measurement linked to the analog output by injection.
3. Check the consistency between the value measured by Sepam and the indication given by the device connected to the analog output.

Project:..... Type of Sepam

Switchboard: Serial number

Cubicle: Software version V

Overall checks

Check off the box when the check has been made and been conclusive

Type of check

Preliminary general examination, prior to energizing	<input type="checkbox"/>
Energizing	<input type="checkbox"/>
Parameter and protection settings	<input type="checkbox"/>
Logic input connection	<input type="checkbox"/>
Logic output connection	<input type="checkbox"/>
Validation of the complete protection chain	<input type="checkbox"/>
Validation of the customized logic functions (if necessary)	<input type="checkbox"/>
Analog output connection to the MSA141 module (if necessary)	<input type="checkbox"/>
Temperature sensor input connection to the MET148-2 module (for type T40, T42, T50, T52, M40, M41, G40)	<input type="checkbox"/>

Checking of phase current and voltage inputs

Check off the box when the check has been made and been conclusive

Type of check	Test performed	Result	Display
Phase current and phase voltage input connection	Secondary injection of CT rated current, i.e. 1 A or 5 A	CT rated primary current	I1 = <input type="checkbox"/>
			I2 =
			I3 =
	Secondary injection of phase voltage (the value to be injected depends on the test being performed)	VT rated primary phase-to-neutral voltage $U_{ns}/\sqrt{3}$	V1 = <input type="checkbox"/>
			V2 =
			V3 =
Phase displacement $\varphi(V, I) \approx 0^\circ$			$\varphi1 = \dots\dots\dots$ <input type="checkbox"/>
			$\varphi2 = \dots\dots\dots$
			$\varphi3 = \dots\dots\dots$

Tests performed on:	Signatures
By:	

Comments:

.....

.....

.....

7

Project:..... Type of Sepam

Switchboard: Serial number

Cubicle:..... Software version **V**

Checking of residual current and residual voltage inputs

Check off the box when the check has been made and been conclusive

Type of check	Test performed	Result	Display
Residual current input connection	Injection of 5 A into the core balance CT primary circuit	Injected current value	I0 = <input type="checkbox"/>
	When applicable, secondary injection of the rated phase-to-neutral voltage of a phase VT $U_{ns}/\sqrt{3}$	VT rated primary phase-to-neutral voltage $U_{np}/\sqrt{3}$	V0 =
		Phase displacement $\varphi (V0, I0) \approx 0^\circ$	$\varphi0 = \dots\dots\dots$
Residual voltage input connection	Secondary injection of the rated voltage of the VTs in an open delta arrangement ($U_{ns}/\sqrt{3}$ or $U_{ns}/3$)	VT rated primary phase-to-neutral voltage $U_{np}/\sqrt{3}$	V0 = <input type="checkbox"/>
	When applicable, secondary injection of CT rated current, i.e. 1 A or 5 A	CT rated primary current	I0 =
		Phase displacement $\varphi (V0, I0) \approx 0^\circ$	$\varphi0 = \dots\dots\dots$
Residual current and residual voltage input connection	Injection of 5 A into the core balance CT primary circuit	Injected current value	I0 = <input type="checkbox"/>
	Secondary injection of the rated voltage of the VTs in an open delta arrangement ($U_{ns}/\sqrt{3}$ or $U_{ns}/3$)	VT rated primary phase-to-neutral voltage $U_{np}/\sqrt{3}$	V0 =
		Phase displacement $\varphi (V0, I0) \approx 0^\circ$	$\varphi0 = \dots\dots\dots$

Tests performed on:	Signatures
By:	
Comments:	
.....	
.....	
.....	

Sepam has a large number of self-tests that are carried out in the base unit and additional modules. The purpose of the self-tests is:

- to detect failures that may lead to nuisance tripping or the failure to trip when a fault occurs
- to put Sepam in the fail-safe position to avoid user errors
- to notify the operator that a maintenance operation is required.

The "Sepam diagnosis" screen of the SFT2841 software provides access to data on the status of the base unit and optional modules.

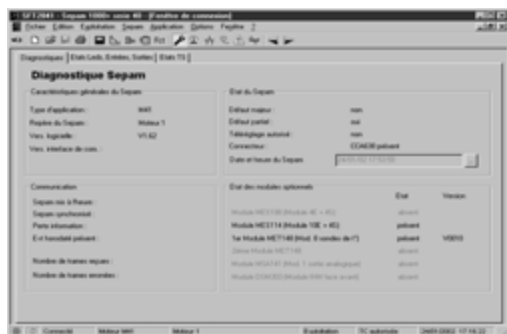

Sepam Diagnosis" screen.

Shutdown of the base unit in fail-safe position

The base unit goes into the fail-safe position in the following conditions:

- detection of an internal failure by the self-tests
- sensor interface connector missing (CCA630, CCA634 or CCA670)
- no connection of one of the 3 LPCT sensors to the CCA670 (connectors L1, L2 and L3)
- MES module configured but missing.

See "List of self-tests which place Sepam in the fail-safe position" page 136.

The fail-safe position is conveyed by:

- ON indicator on
- indicator on the base unit steadily on
- relay O4 "watchdog" in fault position
- output relays dropped out
- all protection units inhibited
- display showing fault message

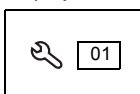

- indicator on DSM303 module (remote advanced UMI option) flashing.

Downgraded operation

The base unit is in working order (all the protection functions activated are operational) and indicates that one of the optional modules such as DSM303, MET148-2 or MSA141 is faulty or else that a module is configured but not connected. See "List of self-tests which do not place Sepam in the fail-safe position" page 136.

According to the model, this operating mode is conveyed by:

- Sepam with integrated advanced UMI (MD base):
- ON indicator on
- indicator on the base unit flashing, including when the display is out of order (off)
- indicator on the MET or MSA module faulty, steadily on.

The display shows a partial fault message and indicates the type of fault by a code:

- code 1: inter-module link fault
- code 3: MET module unavailable
- code 4: MSA module unavailable.
- Sepam with remote advanced UMI, MX base + DSM303:
- ON indicator on
- indicator on the base unit flashing
- indicator on the MET or MSA module faulty, steadily on
- the display indicates the type of fault by a code (same as above).

Special case of faulty DSM303:

- ON indicator on
- indicator on base unit flashing
- indicator on DSM steadily on
- display off.

This Sepam operating mode is also transmitted via the communication link.

RTD fault

Each temperature monitoring function, when activated, detects whether the RTD associated with the MET148-2 module is short-circuited or disconnected.

When this is the case, the alarm message "RTD FAULT" is generated.

Since this alarm is common to the 8 functions, the identification of the faulty RTD or RTDs is obtained by looking up the measured values:

- measurement displayed "*****" if the sensor is short-circuited ($T < -35\text{ °C}$ or -31 °F)
- measurement displayed "-*****" if the sensor is disconnected (or $T > +205\text{ °C}$ or $+401\text{ °F}$)

Other faults

Specific faults indicated by a screen:

- DSM303 version incompatible (if version $< V0146$).

NOTICE**HAZARD OF DAMAGE TO SEPAM**

- Do not open the Sepam base unit.
- Do not attempt to repair any components in the Sepam range, either in the base unit or an accessory.

Failure to follow these instructions can result in equipment damage.

Replacement and repair

When Sepam or a module is considered to be faulty, have it replaced by a new product or module, since the components cannot be repaired.

About SFT2841

Please use SFT2841

≥ 10.0

SFT2841 compatible version screen.

Compatibility of Sepam version/SFT2841 version

The About SFT2841 screen indicates the minimum version of SFT2841 that is compatible with the Sepam being used.

To display this screen on the Sepam UMI, press the  key several times to bring up the SFT2841 compatible version screen.

Check that the SFT2841 software version used is higher than or the same as that indicated on the Sepam screen.

If the SFT2841 software version is lower than the minimum version compatible with the Sepam being used, the SFT2841 software cannot be connected to Sepam and the SFT2841 software displays the following error message: SFT2841 software version incompatible with the connected device.

Preventive maintenance**General**

The logic inputs and outputs and the analog inputs are the parts of Sepam least covered by the self-tests. (See "List of self-tests which place Sepam in the fail-safe position" page 136).

They should be tested during a maintenance operation.

The recommended interval between preventive maintenance operations is 5 years ⁽¹⁾.

Maintenance tests

To perform maintenance on Sepam, see section "Sepam commissioning tests" page 286. Carry out all the recommended commissioning tests according to the type of Sepam to be tested.

First test all the logic inputs and outputs involved in tripping the circuit breaker.

A test of the complete chain including the circuit breaker is also recommended.

(1) For more details about the maintenance period, see "Precautions", page 201.

⚡ ⚠ DANGER**HAZARD OF ELECTRIC SHOCK, ELECTRIC ARC OR BURNS**

■ Only qualified personnel should maintain this equipment. Such work should be performed only after reading this entire set of instructions.

■ NEVER work alone.

■ Obey all existing safety instructions when commissioning and maintaining high-voltage equipment.

■ Beware of potential hazards and wear personal protective equipment.

Failure to follow these instructions will result in death or serious injury.

Firmware evolutions

The table below describes the firmware version history of the Sepam base.

The following information is provided for each firmware version:

- release date,
- compatible base version(s),
- serial number range of compatible Sepam bases,
- new features added to the Sepam base.

The base version represents the hardware version of the Sepam base.

Firmware version	Firmware version release date	Compatible base version	Base serial number	New features
V1.00	July 2001	Base 1	0132001 to 0209062	First version
V2.00	March 2002	Base 1	0209063 to 0527999	<ul style="list-style-type: none"> ■ New applications added: G40, M41, S42, T40 and T42 ■ Logic equation editor and customized messages available ■ CTs and energy monitoring available ■ Compliance with the new MSA141 analog output module and the new MET148-2 temperature sensor module
V3.00	July 2005	Base 1	0528001 to 0622999	<ul style="list-style-type: none"> ■ Compliance with the new ACE969 multi-protocol interfaces ■ Remote connection of Sepam setting software SFT2841 V8.0 and higher
V4.00	June 2006	Bases 1, 2, 3 and 4	0623001 to 0722999	<ul style="list-style-type: none"> ■ Metering 3 phase currents with only 2 CTs ■ Communication protocol DNP3: new possibility to set the threshold of the measurement dead band that starts the transmission event. ■ Sepam time and date setting using the setting software SFT2841
V5.00	June 2007	Bases 1, 2, 3 and 4	0723001 to 08129999	<ul style="list-style-type: none"> ■ 49 RMS function (Thermal overload) improvement: <ul style="list-style-type: none"> □ Improvement of the functioning time accuracy when tripping has to occur in a few seconds □ Use of 48/51LR (excessive starting time and locked rotor) protection threshold instead of the actual fixed threshold to detect the motor starting □ Improvement of the choice of setting groups to take into account the appropriate time constants as soon as the motor starts ■ Pre-assigned remote indication bit TS130 for the tripping information is now available in communication
V5.03	August 2008	Bases 1, 2, 3 and 4	08130001 to 09139999	New application S43 added
V6.00	March 2009	Bases 1, 2, 3 and 4	09140001 to 09349999	<ul style="list-style-type: none"> ■ Supervision communication is checked by using remote control orders (TC) broadcasting. If the TC is not received in the correct setting time interval, the Sepam trips. ■ Inductive and capacitive remote indication (TS) event generation disabled to prevent logbook saturation on underload networks
V6.01	September 2009	Bases 1, 2, 3 and 4	09350001 to 09499999	Hardware evolution of the Sepam series 40 base 3.
V6.02	March 2010	Bases 1, 2, 3 and 4		New harmonic 2 restraint function on the earth fault protection (ANSI 50N/51N)
V6.05	October 2010	Bases 1, 2, 3 and 4		Same event list management for all Sepam (series 20, series 40 and series 80).
V7.00	December 2009	Bases 3 and 4	09500001 to 10469999	<ul style="list-style-type: none"> ■ New applications added: S50, S51, S52, S53, T50 and T52 applications created based on the S40, S41, S42, S43, T40 and T42 applications enhanced with the following functions: <ul style="list-style-type: none"> □ Fault locator function (ANSI 21FL) □ Broken conductor protection (ANSI 46BC) □ Cold load pick-up on I and Io functions. ■ New functions added on all applications: <ul style="list-style-type: none"> □ Cable arcing fault detection (based on an harmonic 2 restraint function on ANSI 50/51) □ New harmonic 2 restraint function on the earth fault protection (ANSI 50N/51N) □ Supervision communication is checked by using remote control orders (TC) broadcasting. If the TC is not received in the correct setting time interval, the Sepam trips. □ Inductive and capacitive remote indication event generation disabled to prevent logbook saturation on underload networks □ Under voltage functions (ANSI 27/27S) setting point □ Positive sequence under voltage function (ANSI 27D) setting point
V7.04	November 2010	Base 3 and 4	10470001 to 11169999	Same event list management for all Sepam (series 20, series 40 and series 80).
V8.00	April 2011	Base 3 and 4	11170001	■ New applications M40, S44 and S54
V8.08	January 2025	Base 3 and 4	To be updated	■ New X41 application for managing self-tests after long-term storage.

General upward compatibility

The following table presents the compatibility of a firmware version with the different hardware base versions.

Firmware version	Hardware evolutions			
	Base 1	Base 2 June 2006	Base 3 August 2009	Base 4 July 2010
1.XX	□	-	-	-
2.XX	□	-	-	-
3.XX	□	-	-	-
4.XX	□	□	□	□
5.XX	□	□	□	□
6.00	□	□	□	□
6.01	□	□	□	□
6.02	□	□	□	□
6.05	■	■	□	□
7.XX	-	-	□	□
8.XX	-	-	■	■

- *compatible with all features*
- *compatible but with limited features*
- *not compatible*

Nota : Sepam firmware versions V7.00 and above are compatible only with Sepam bases 3 and above, manufactured after August 2009, with a serial number above 09350001.

Nota : The disturbance-recording backup function is available only with Sepam bases 4 and above, with a serial number above 10300001.

Schneider Electric Industries SAS

35, rue Joseph Monier
CS 30323
F - 92506 Rueil-Malmaison Cedex
RCS Nanterre 954 503 439
Capital social 896 313 776 €
www.schneider-electric.com

As standards, specifications and designs change from time to time, please ask for confirmation of the information given in this publication.



Printed on recycled paper.

Production: Schneider Electric
Publication: Schneider Electric
Printed: