

Safety Information

Electrical equipment should be installed, operated, serviced, and maintained only by qualified personnel. No responsibility is assumed by Schneider Electric for any consequences arising out of the use of this material.

A qualified person is one who has skills and knowledge related to the construction, installation, and operation of electrical equipment and has received safety training to recognize and avoid the hazards involved.

Esmi Impresia Multicriteria Detector

Esmi Impresia Multicriteria Detector (FFS06741003) is an addressable combined (temperature and optical-smoke) detector with built-in isolator module, designed for installing in addressable fire alarm systems with Esmi ELC loop controller supporting Schneider Electric communication protocol. The detector sensitivity can be configured with software. The detector is compatible with Esmi Impresia Standard Base (FFS06741018) and Esmi Impresia Standard Base High Profile (FFS06741028). The address setting is done by the panel, QR code or handheld addressing device. The address range is 1-250.

For more technical information visit www.se.com.

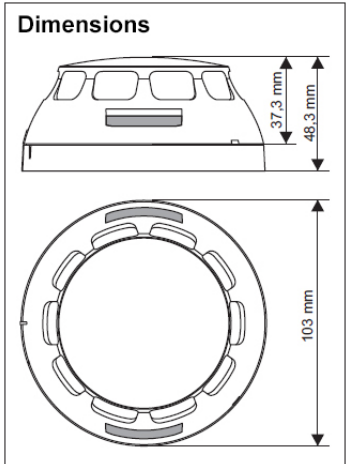

⚠ WARNING
HAZARD OF COMPROMISED DETECTION FUNCTIONALITY.
<ul style="list-style-type: none"> Dust covers help to protect units during shipping and when first installed. Sensors should be removed before construction, major re-decoration or other dust producing work is started.
Failure to follow these instructions can result in death or serious injury.

Installation

Note: Collect the QR code stickers from the devices if QR codes are used for addressing of the devices.

- Follow the applicable local and national installation codes and regulations.
 - IMPORTANT:** Do not install the detector near sources of steam, smoke, condensation or heat.
- If needed, lock the detector to the base by removing a small tab on the detector as shown on the picture 1.
- Install the detector base into a flat surface by using appropriate screws.
- The loop power must be disconnected during installation.
- Connect the loop wiring as shown on picture 3.
- Insert the detector to the base by turning it clockwise on the base until it drops into place. A stripe on the detector side match to the short stipe of the base. Continue to turn the detector until the stripe on the detector meet the longer stipe on the base - a click is heard. See picture 4.
- Test the detector functionality with Solo no climb tester.

If the detector is locked into the base it can be removed by pressing the lid with a small flat head screwdriver and gently turning the detector counter clockwise at the same time.

Installation	
IP30	Indoor use
-10°C + +60°C	
~94,5g without base.	

Testing

Before testing make sure all persons in the building are aware of the test! If needed disconnect fire alarm devices, alarm transmitters and other fire outputs before the test. Use Solo "No Climb" tester to test the detector after installation. Follow the testers manufacturer instruction how to run smoke and heat tests.

Technical Specifications

Operating Voltage Range	16 - 32VDC (Nom. 27VDC)
Consumption in quiescent state, no communication	< 190µA@27VDC
Consumption in quiescent state, with communication	< 310µA@27VDC
Consumption in alarm state, with communication	6.5mA
Class (in accordance with EN54-5)	A1/R Sensitivity level
- High/ Normal*/ Middle/ Low	*in accordance with EN54-7
Output in alarm state at terminal RI (terminals 4/ 1)	7.5 mA (max)/ 7.5V
Wire Gauge for terminals	0.4mm ² ÷ 2.0mm ²
Relative humidity resistance	(93 ± 3)% @ 40°C
Weight	95 g
Supported communication protocol	.Esmi ELC

Essential Characteristics According to EN 54	Performance
Performance under fire conditions	Pass
Operational reliability	Pass
Durability:	
Temperature resistance	Pass
Humidity resistance	Pass
Shock and vibration resistance	Pass
Corrosion resistance	Pass
Resistance to ingress	Pass
Electrical stability	Pass

CE 22
1293
DoP No: DP20019
Made in Bulgaria
EN 54-5:2017+A1:2018
EN 54-7:2018
EN 54-17:2005/AC:2007
Detector Class A1/R

Schneider Electric Buildings AB
Mobilvägen 8
22362 Lund
Sweden

