

# Prisma G IP30

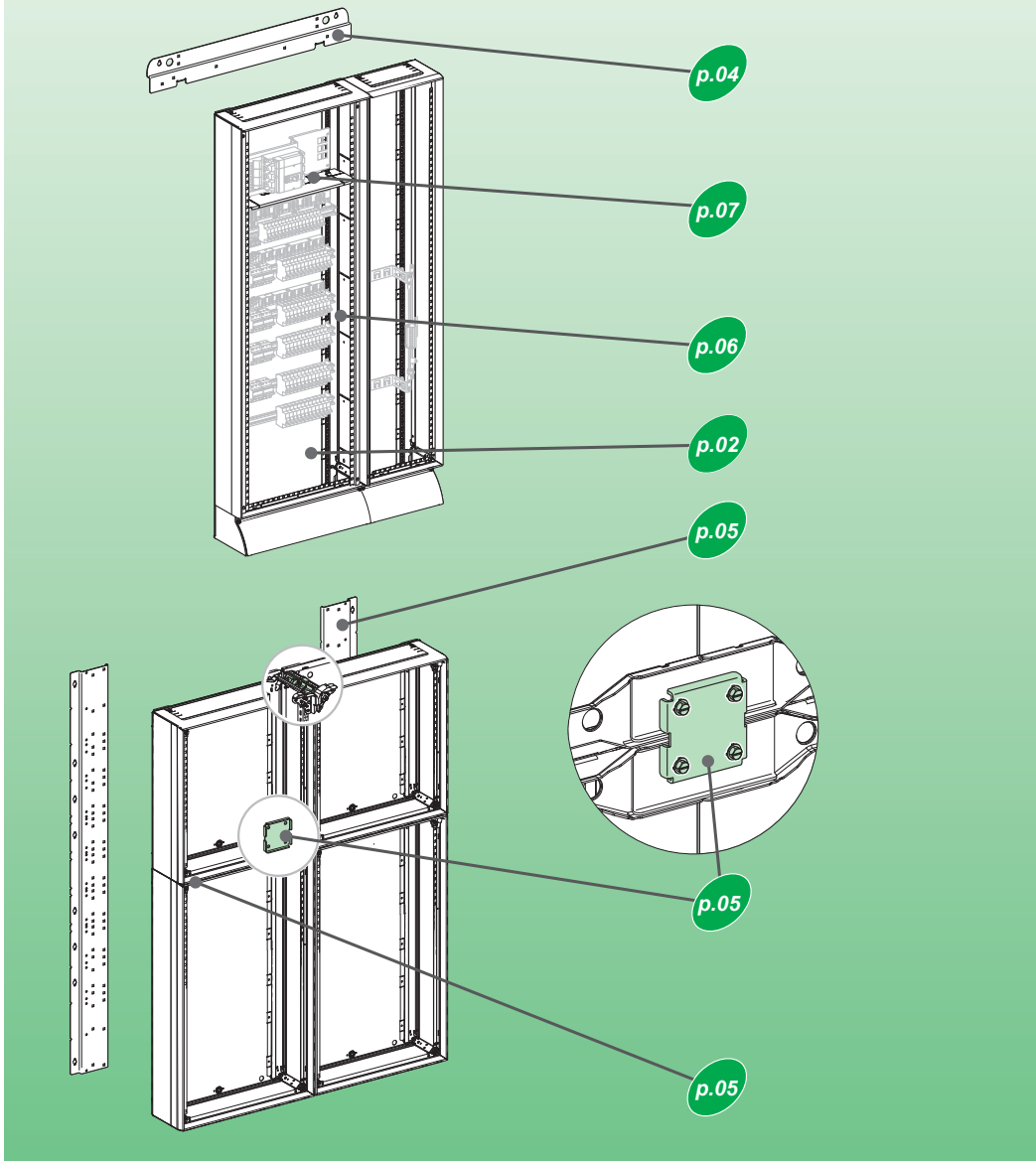

- 08113 / 08114 / 08115 p.02
- 08116 / 08117 / 08118
- 08119 / 08172 / 08173
- 08174 / 08175 / 08176
- 08177 / 08178 / 08179
- 08212 / 08213 / 08214 p.02
- 08215 / 08272 / 08273
- 08274 / 08275
- 08809 / 08811 / 08812 p.04
- 08813 / 08814 / 08826
- 08816 p.05
- 08882 / 08885 p.05
- 08817 / 08818 p.05
- 04330 / 04335 p.06
- 04331 / 04332 / 04336 p.07

<p>The instructions given in this document describe the assembly of Prisma switchboards in compliance with certification CEI61439 1 and 2.</p> <p>Electrical equipment should be installed, operated, serviced, and maintained only by qualified personnel.</p> <p>Failure to follow the assembly instructions is the installer's responsibility. No responsibility is assumed by Schneider Electric for any consequences arising out of the use of this material in case of failure to comply with the assembly instructions.</p>	<p>Les instructions de ce document décrivent le montage des tableaux Prisma en conformité avec la certification CEI61439-1 &amp; 2.</p> <p>L'installation, l'utilisation, la réparation et la maintenance des équipements électriques doivent être assurées uniquement par du personnel qualifié.</p> <p>Le non respect des instructions de montage est de la responsabilité du metteur en oeuvre. Schneider Electric décline toute responsabilité quant aux conséquences de l'utilisation de ce matériel en cas de non respect des instructions de montage.</p>	<p>Las instrucciones proporcionadas en este documento describen el montaje de los cuadros Prisma según la certificación IEC 61439 1 y 2.</p> <p>La instalación, manejo, puesta en servicio y mantenimiento de equipos eléctricos deberán ser realizados sólo por personal cualificado.</p> <p>Es responsabilidad del instalador seguir todas las instrucciones de montaje. En caso de incumplimiento de las instrucciones de montaje, Schneider Electric no se hace responsable de ninguna de las consecuencias derivadas del uso de este material.</p>	<p>Die Anweisungen in diesem Dokument beschreiben die Montage von Prisma-Schaltanlagen in Übereinstimmung mit der Zertifizierung IEC 61439-1 und -2.</p> <p>Elektrische Geräte dürfen nur von Fachpersonal installiert, betrieben, bedient und gewartet werden.</p> <p>Die Nichtbeachtung der Montageanweisungen liegt in der Verantwortung des Montagetechnikers. Schneider Electric haftet in keinem Fall für Folgen jeglicher Art, die sich aus der Verwendung dieses Materials bei Nichtbeachtung der Montageanweisungen ergeben.</p>
<p>Le istruzioni fornite nel presente documento descrivono l'assemblaggio dei quadri principali Prisma in conformità con la certificazione CEI61439 1 e 2.</p> <p>Installazione, utilizzo, manutenzione e assistenza dell'apparecchiatura elettrica devono essere affidate solo a personale qualificato.</p> <p>L'installatore è responsabile della mancata osservanza delle istruzioni di assemblaggio. Schneider Electric non si assume alcuna responsabilità per qualsiasi conseguenza derivante dall'uso del presente materiale in caso di mancata osservanza delle istruzioni di assemblaggio.</p>	<p>As instruções indicadas neste documento descrevem a montagem de quadros de distribuição Prisma em conformidade com a certificação CEI61439 1 e 2.</p> <p>O equipamento eléctrico deve ser instalado, utilizado, reparado e mantido apenas por pessoal qualificado.</p> <p>A não observância das instruções de montagem é da responsabilidade do instalador. A Schneider Electric não assume responsabilidade por quaisquer consequências resultantes da utilização deste material se as instruções de montagem não forem lidas.</p>	<p>本文档中的说明描述了按照 CEI61439 1 及 2 标准装配 Prisma 配电盘的方式。</p> <p>电气设备的安装、操作、维修及维护必须由合格人员来执行。</p> <p>不遵守装配说明所导致的后果应由安装人员承担。</p> <p>对于因不遵守装配说明而在使用本材料的过程中所出现的任何后果，Schneider Electric 概不负责。</p>	<p>Инструкции, представленные в этом документе, описывают сборку распределительных щитов Prisma в соответствии с требованиями сертификации CEI61439 1 и 2.</p> <p>Установка, эксплуатация, ремонт и обслуживание электрического оборудования должны выполняться только квалифицированными специалистами.</p> <p>За несоблюдение инструкций по сборке ответственность несет организация, выполняющая установку. В случае несоблюдения инструкций по сборке компания Schneider Electric не принимает на себя никакой ответственности за какие бы то ни было последствия, имевшие место вследствие использования данного материала.</p>

**i**<sub>1</sub>

p.03

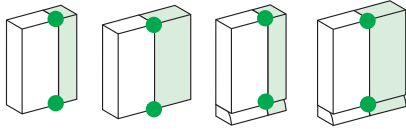

p.04

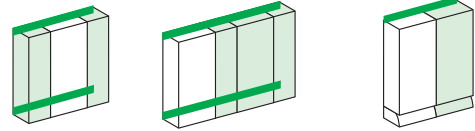

**i**<sub>2</sub>

p.05

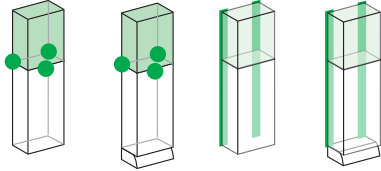

**i**<sub>3</sub>

p.05

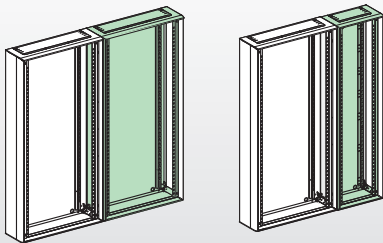
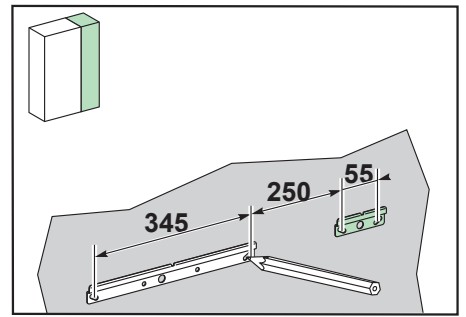
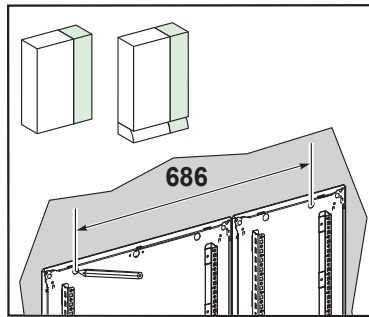
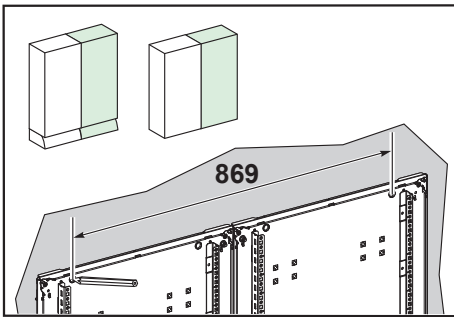
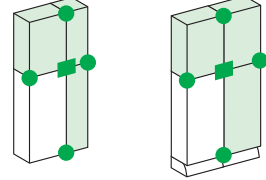

- 08113 08172
- 08114 08173
- 08115 08174
- 08116 08175
- 08117 08176
- 08118 08177
- 08119 08178
- 08179

M6 x 12 x4

x2

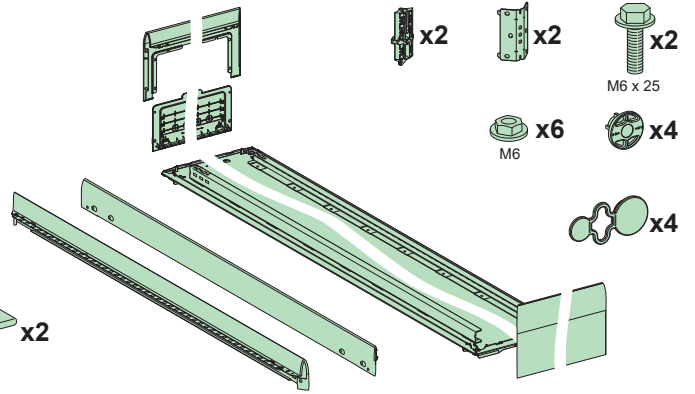

x2

x2

x2

M6 x 25

x6

M6

x4

x4

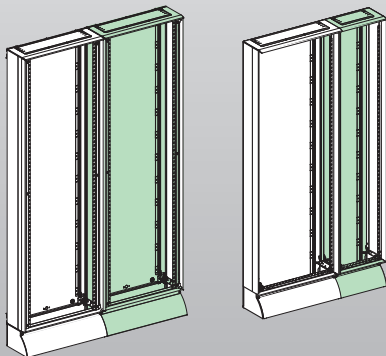

- 08212 08272
- 08213 08273
- 08214 08274
- 08215 08275

M6 x 12 x4

x2

M6 x 12

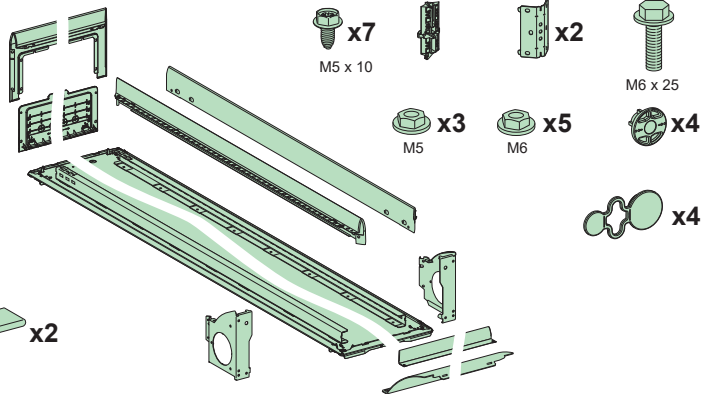

x7

M5 x 10

x2

x2

x2

M6 x 25

x3

M5

x5

M6

x4

x4

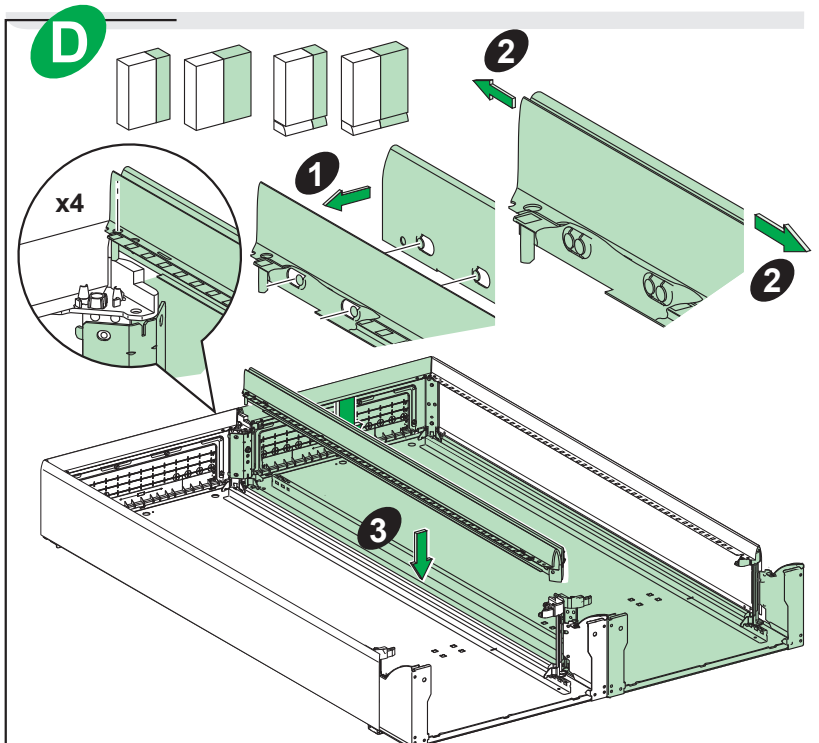
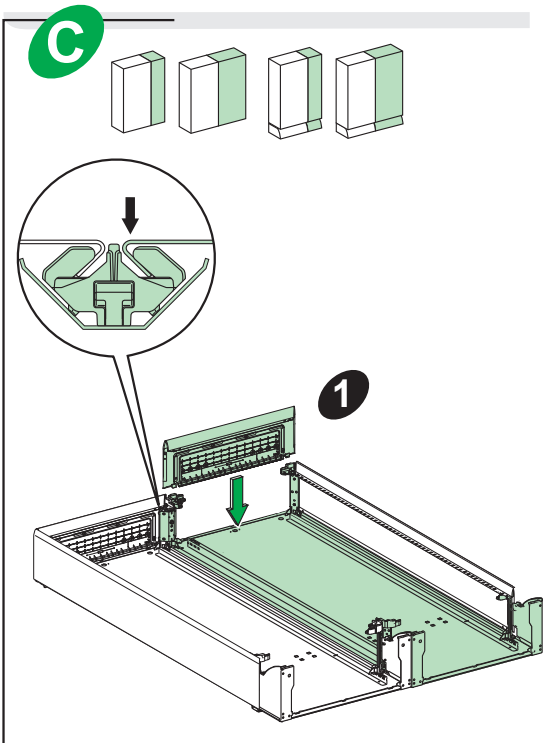
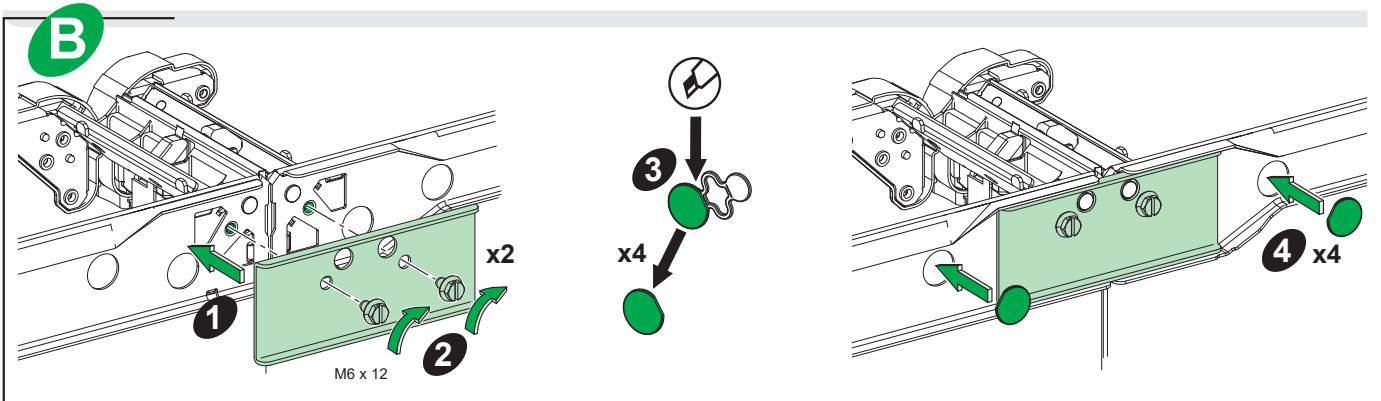
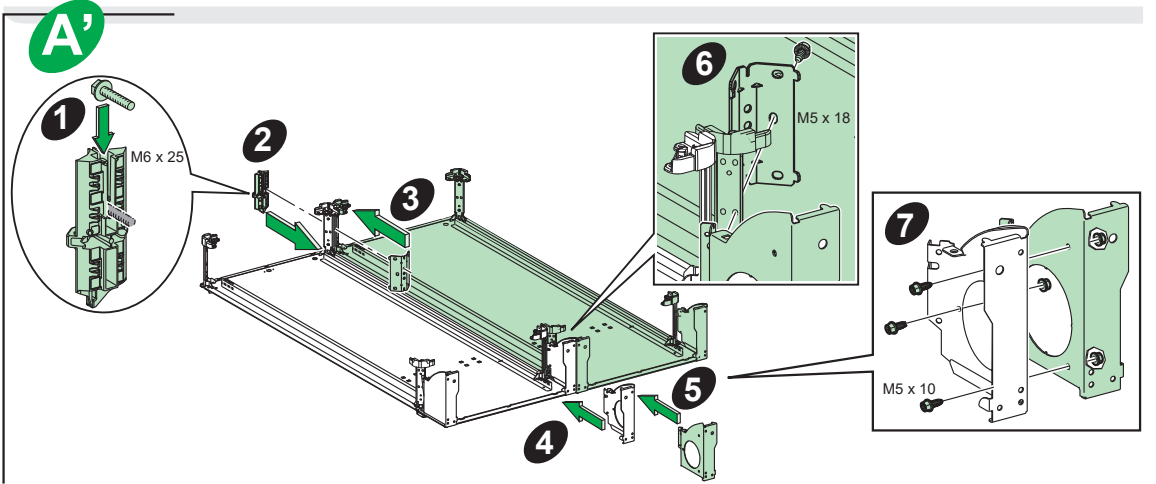
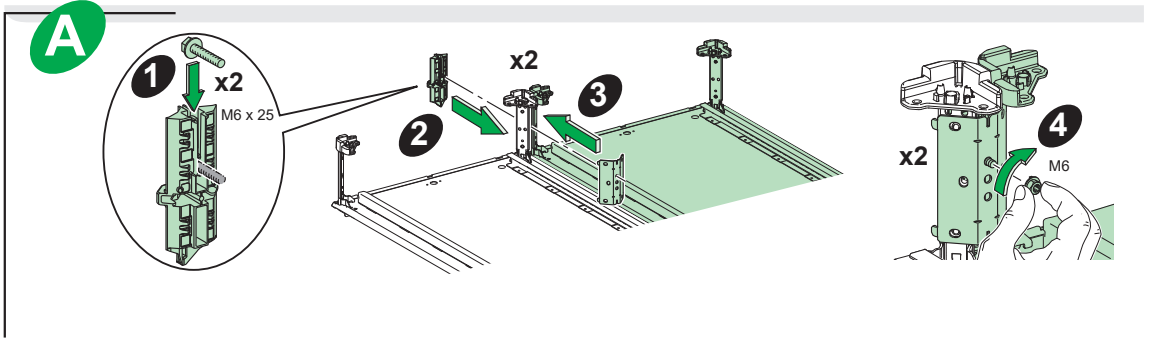

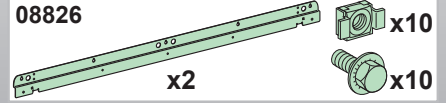
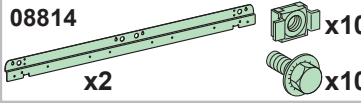
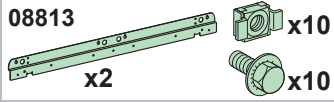
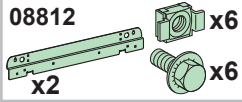
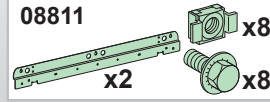
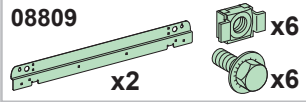
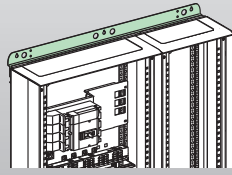
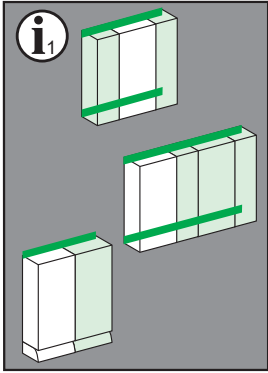

**A**

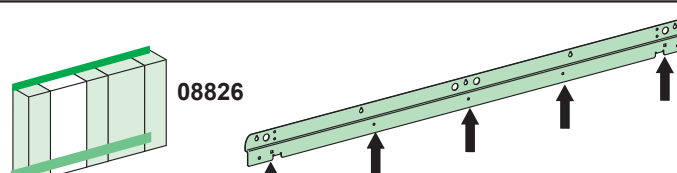
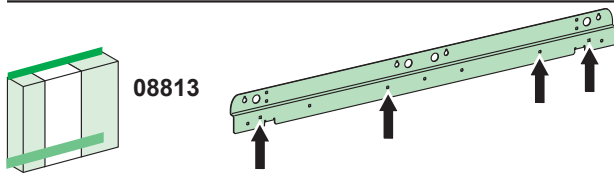
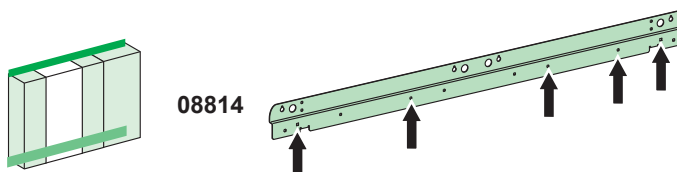
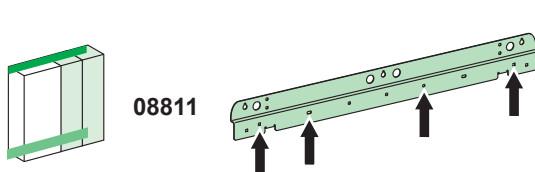
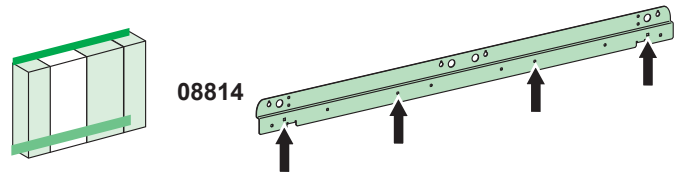
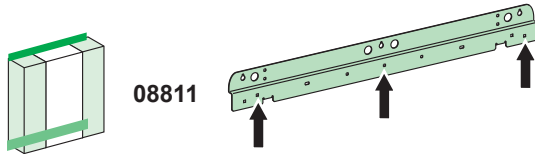
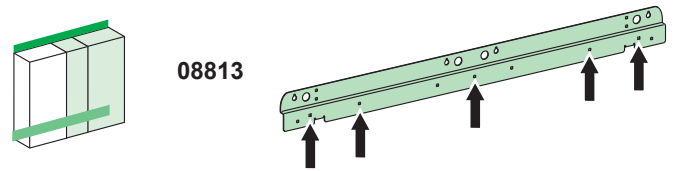
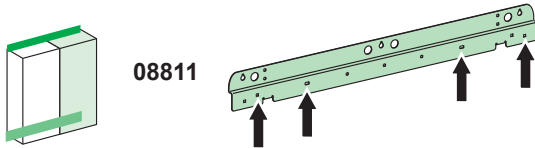
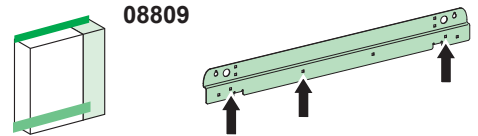
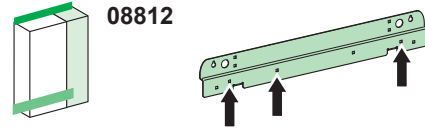
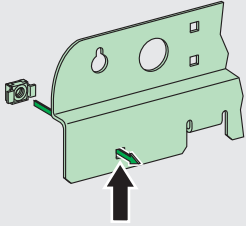

**B**

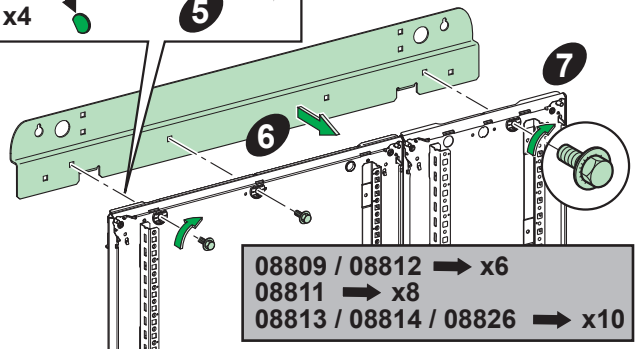
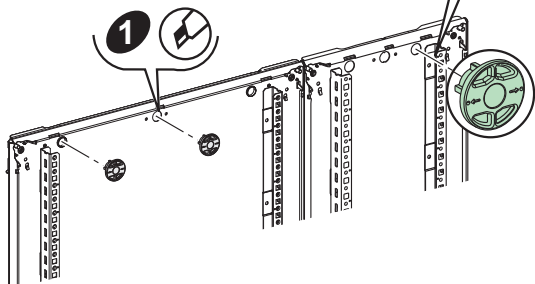
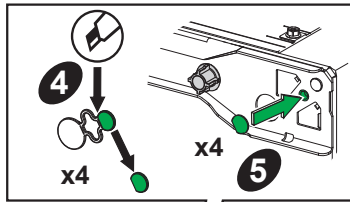
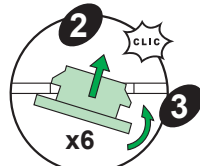
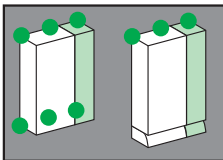

08809 / 08812 → x6  
 08811 → x8  
 08813 / 08814 / 08826 → x10



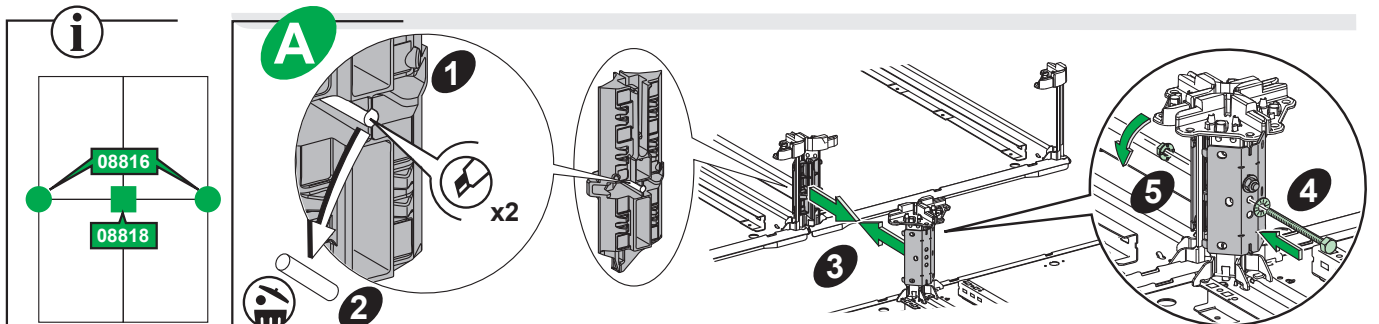
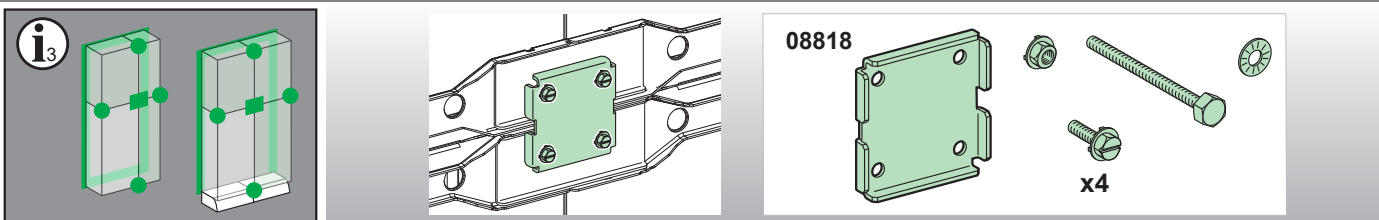
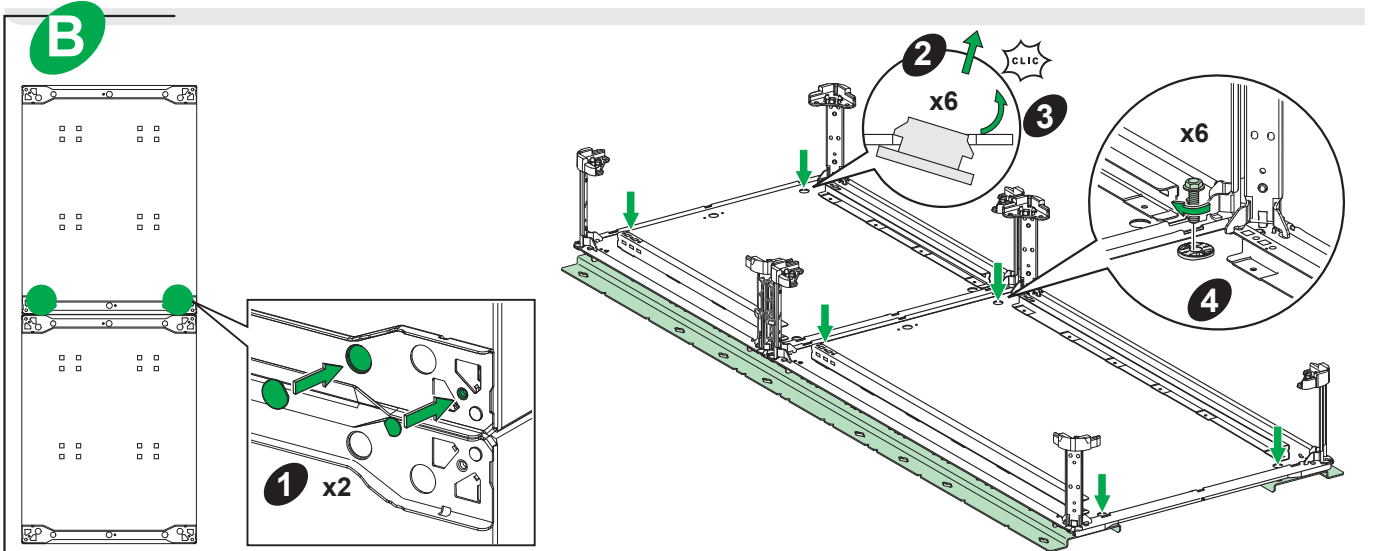
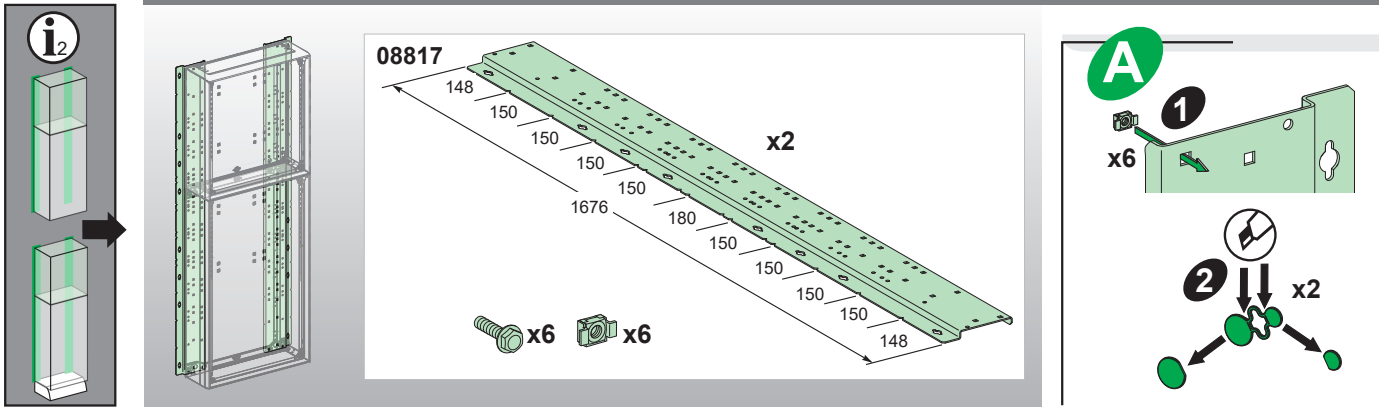
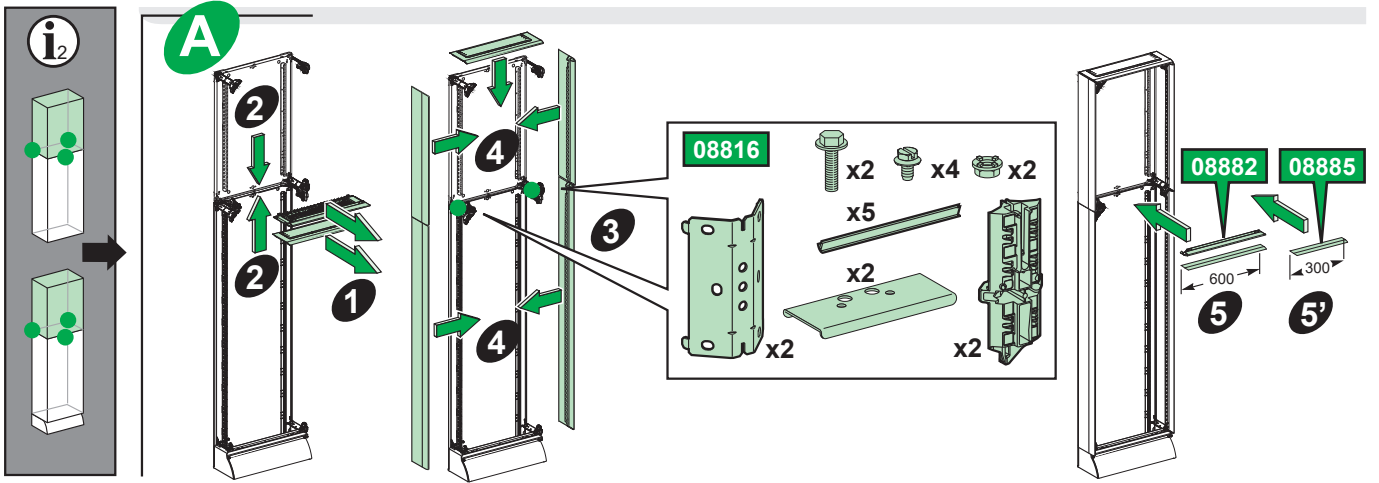

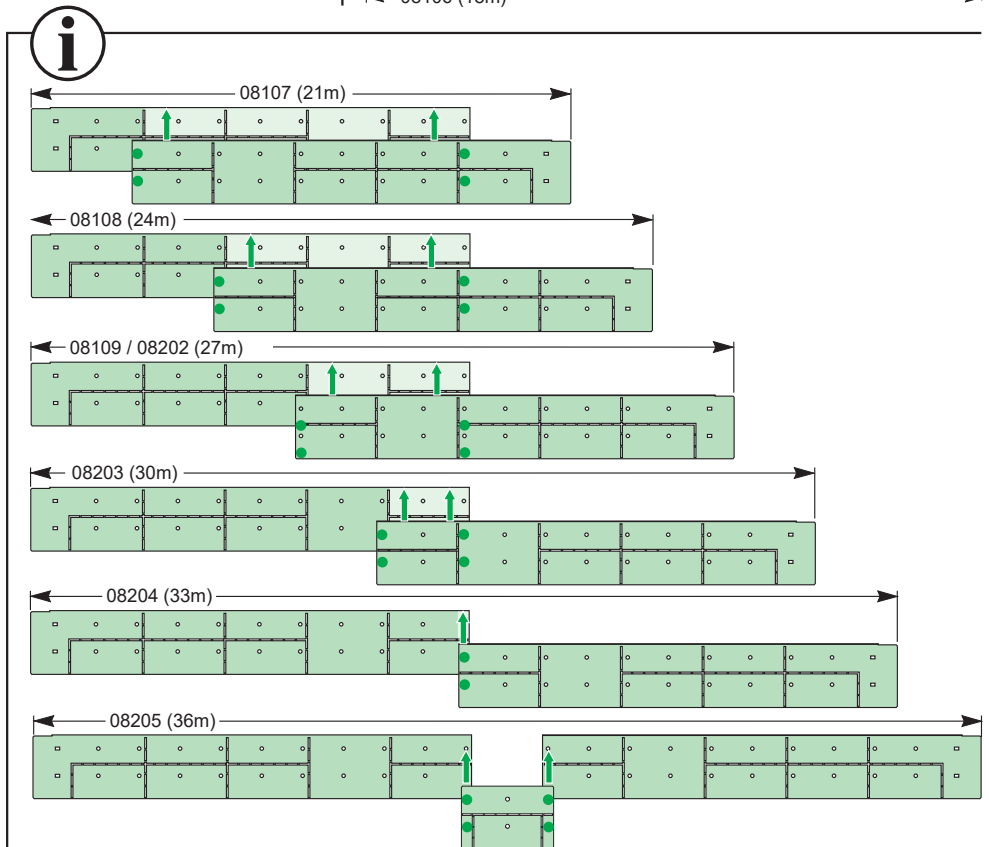
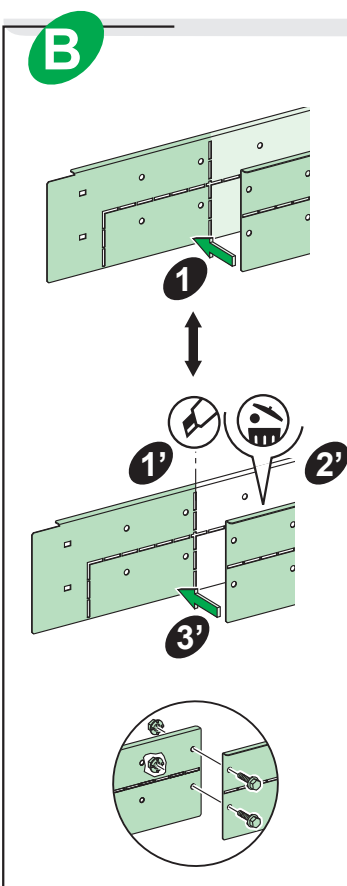
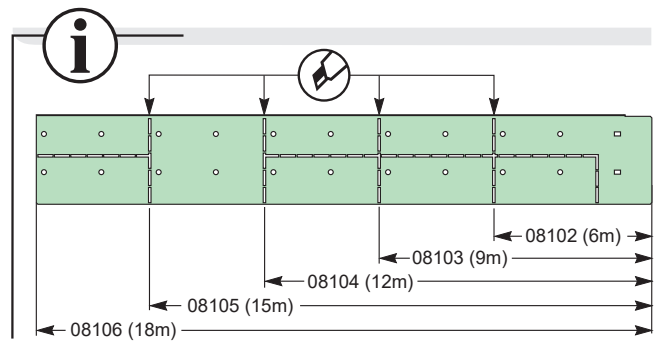
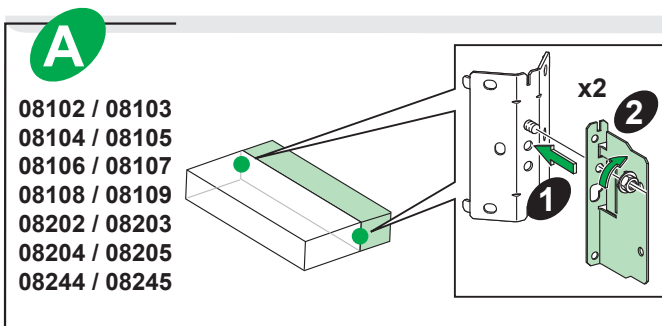
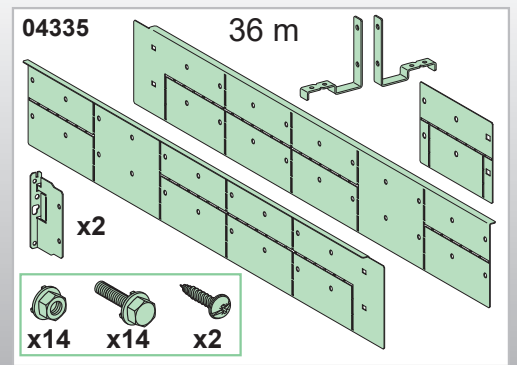
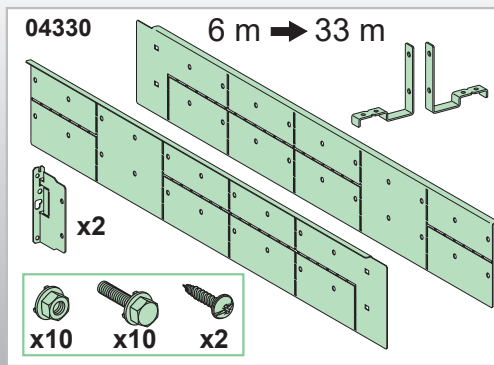
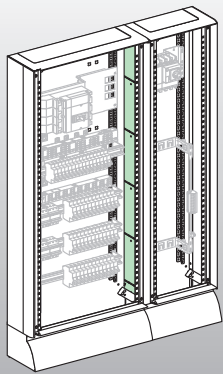
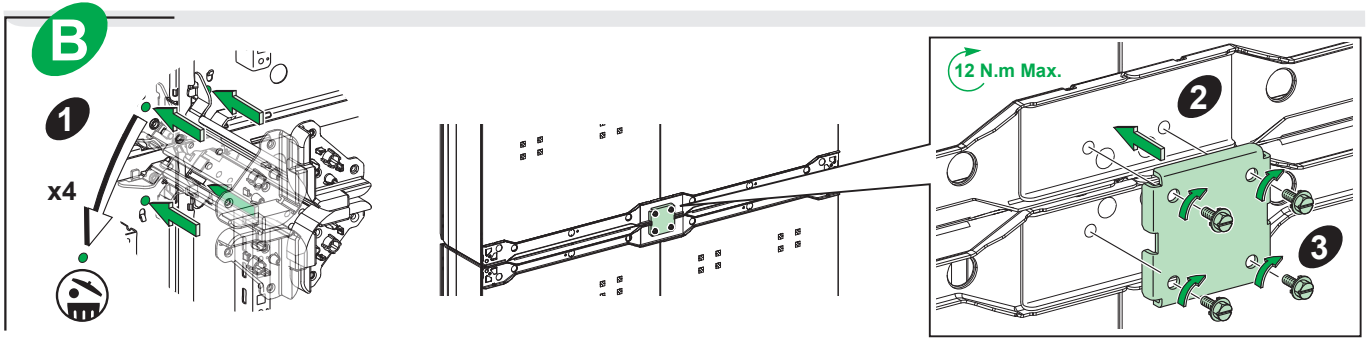

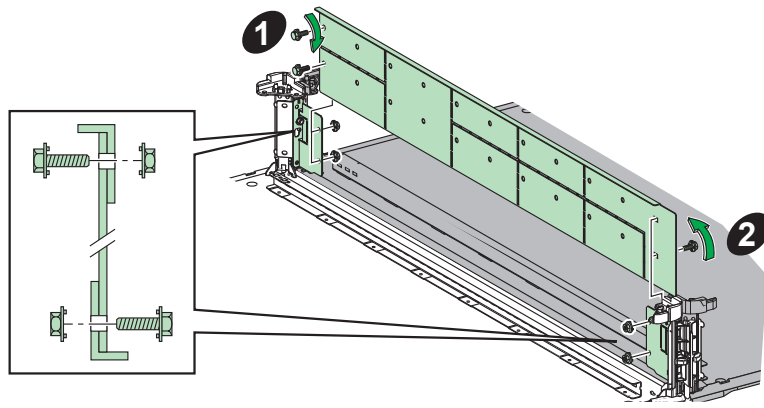
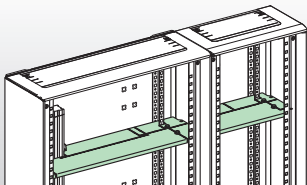
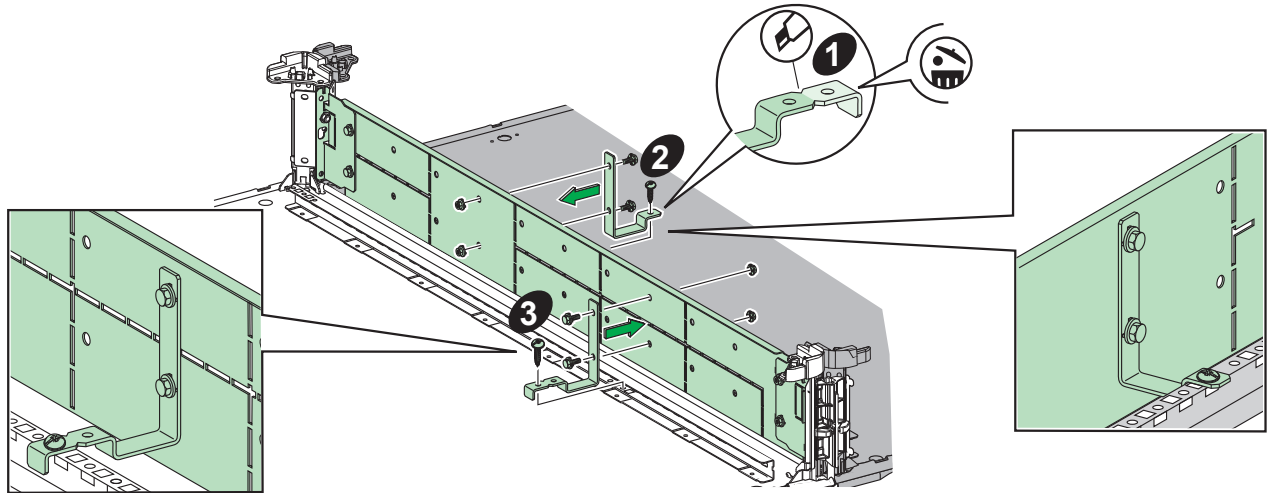
**C****D**

04331 x2

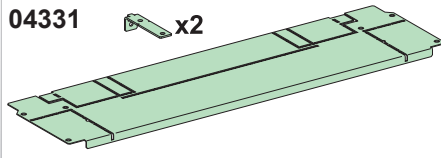

04332

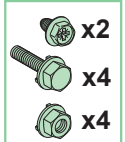
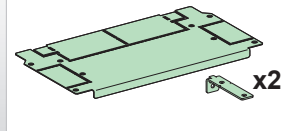

04336

x2

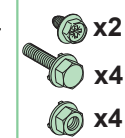
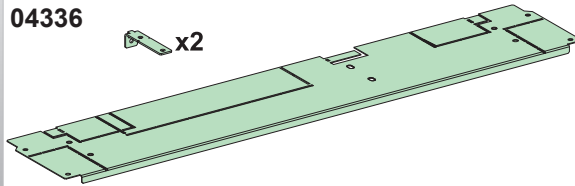
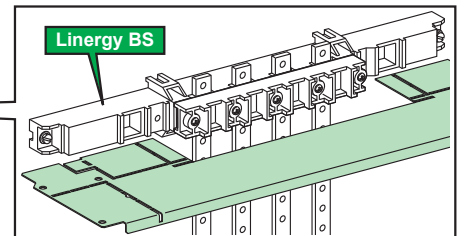
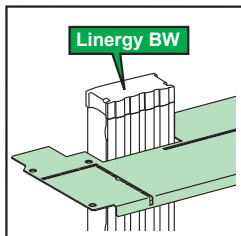
**A**04331  
04336

**B**

04331 / 04332 / 04336

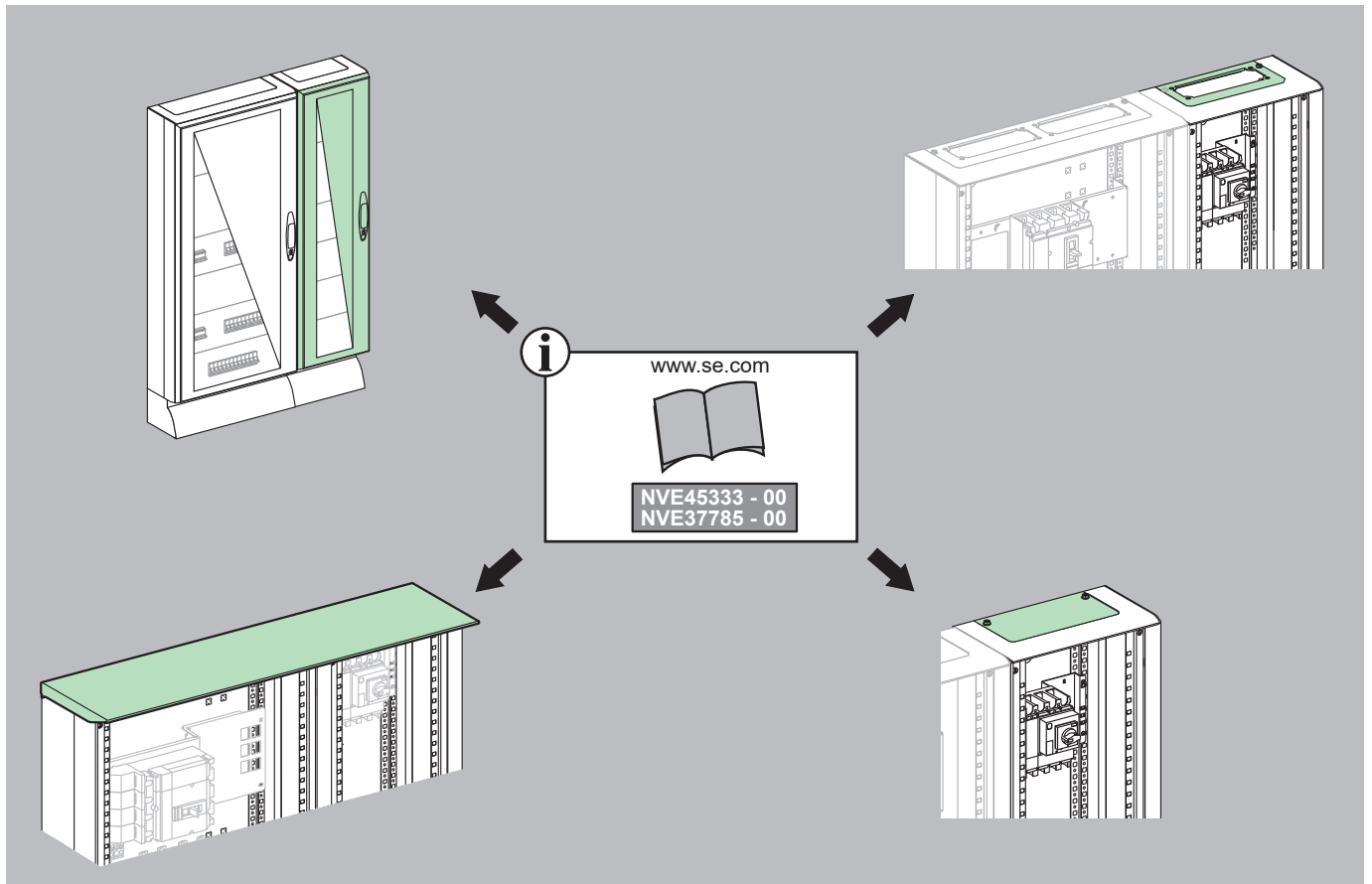
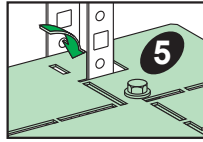
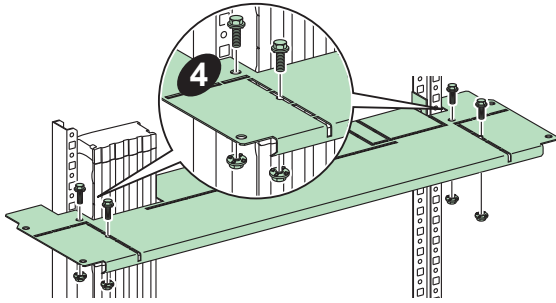
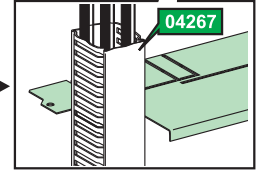
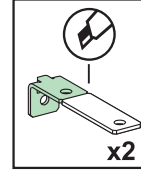
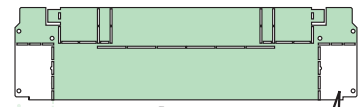
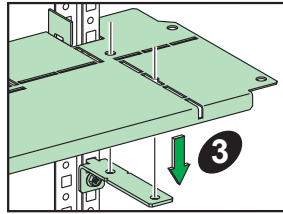
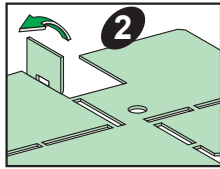
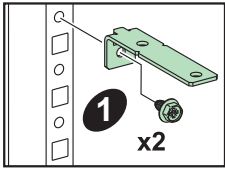
**Schneider Electric Industries SAS**

35, rue Joseph Monier  
92500 Rueil-Malmaison  
France

www.se.com

NVE45335 - 00

En raison de l'évolution des normes et du matériel, les caractéristiques indiquées par le texte et les images de ce document ne nous engageant qu'après confirmation par nos services.

*As standards, specifications and designs change from time to time, please ask for confirmation of the information given in this publication.*

Publication : Schneider Electric  
Réalisation :  
Impression :  
format de pliage : 210 x 297



Ce document a été imprimé sur du papier écologique.

This document has been printed on ecological paper.

05/2021