



NVE3860701-12



i

en PM2225 meter
To download user manuals and other documentation, visit www.se.com, select your country/region and search for your meter model number (for e.g., PM2225).

Refer to the user manual when you see this icon.

zh PM2225 系列测量仪
要下载用户手册和其他文档，请访问 www.se.com，选择您所在的国家/地区并搜索您的测量仪的型号（例如，PM2225）。

如果看见此图标，请参考用户指南。

1 Box contents / 装箱单

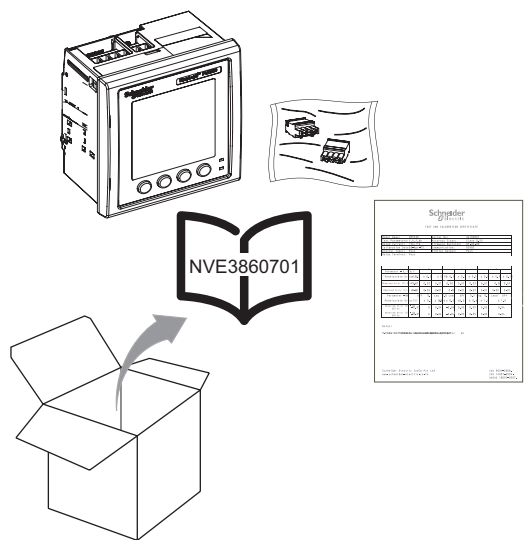

Commercial reference / 产品物料号	RS-485	Class 0.5S	Digital I/O / 数字 I/O	Analog I/O / 模拟 I/O	Relay / 继电器
METSEPM2225CL05	<input checked="" type="checkbox"/>	<input checked="" type="checkbox"/>	<input checked="" type="checkbox"/>	-	-
METSEPM2225C2AI2AO	<input checked="" type="checkbox"/>	<input checked="" type="checkbox"/>	-	<input checked="" type="checkbox"/>	-
METSEPM2225C2DI2RO	<input checked="" type="checkbox"/>	<input checked="" type="checkbox"/>	-	-	<input checked="" type="checkbox"/>

Active Energy: Class 1.0 as per IEC 62053-21 / 有功电能：符合 IEC 62053-21 标准 1
Class 0.5S as per IEC 62053-22 / 有功电能：符合 IEC 62053-22 标准 0.5S

en
Note: Do not use the product if it is damaged. Contact Schneider Electric customer care representative for support.

zh
注：如果已损坏，请勿使用该产品。欲获取支持，请联系施耐德客户服务代表。

2 Safety Precautions / 安全措施

⚡ ⚠ DANGER / 危险

- HAZARD OF ELECTRIC SHOCK, EXPLOSION, OR ARC FLASH**
- Apply appropriate personal protective equipment (PPE) and follow safe electrical work practices. See NFPA 70E in the USA or applicable local standards.
 - Turn off all power supplying this device before working on it.
 - Always use a properly rated voltage sensing device to confirm that all power is off.
 - Do not exceed the device's ratings for maximum limits.
 - Do not use this device for critical control or protection applications where human or equipment safety relies on the operation of the control circuit.
 - Always use grounded external CTs for current inputs.

Failure to follow these instructions will result in death or serious injury.

- 电击、爆炸以及弧光危险
- 请穿戴好人员保护设备 (PPE)，并遵守电气操作安全规程。请遵循美国的 NFPA 70E 或适用的当地标准。
 - 开始在设备上工作之前，请先关闭该设备的所有电源。
 - 务必使用额定电压值正确的电压感应设备，以确认所有电源均已关闭。
 - 切勿超过设备的额定最高限值。
 - 当人身或设备安全依赖于控制电路的工作时，不要将本装置用于这样的关键控制或保护应用中。
 - 务必使用接地的外部电流互感器进行电流输入。
- 若不遵循这些说明，将会导致死亡或严重人身伤害。

3

Dimensions / 尺寸

mm
(in)

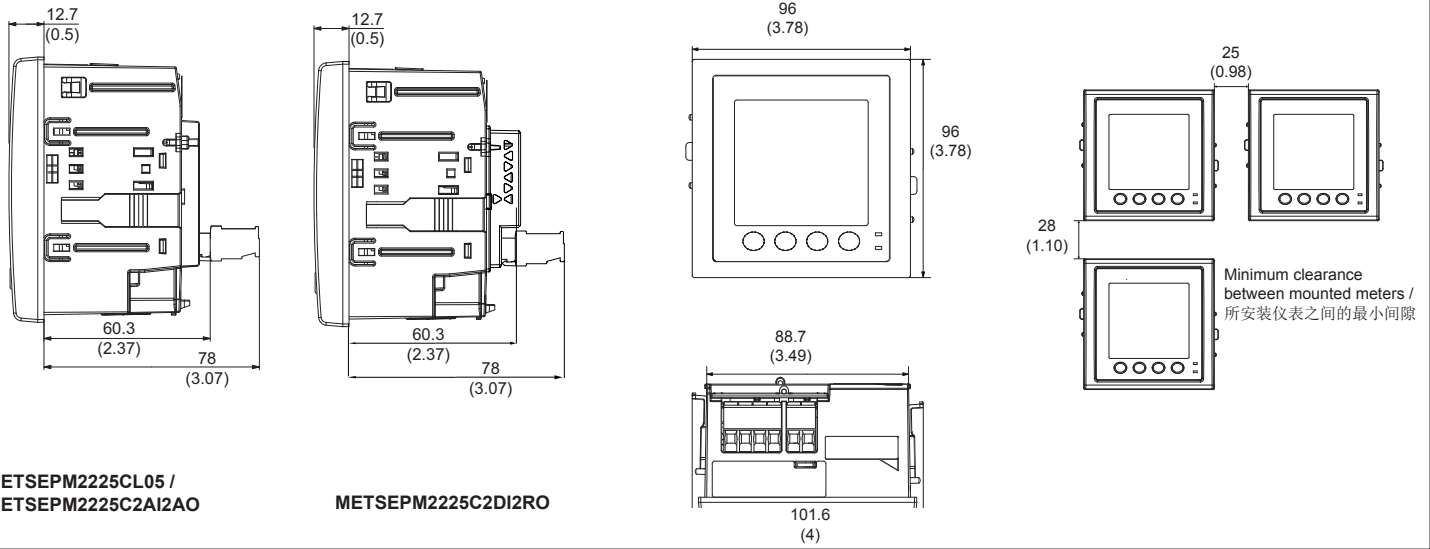

4

Mounting / 安装

mm
(in)

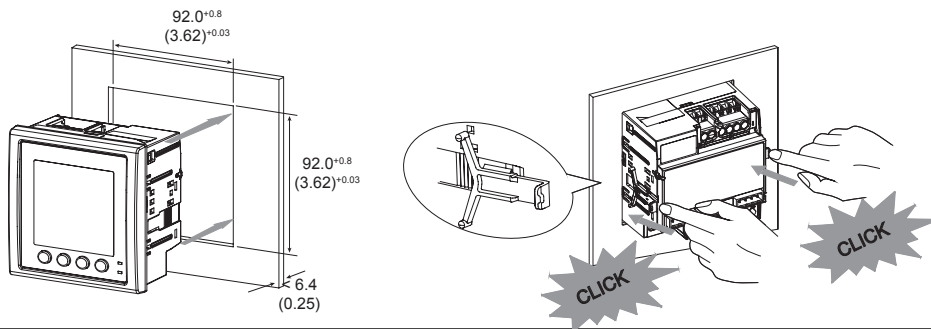

5

Wiring / 接线

METSEPM2225CL05

METSEPM2225C2AI2AO

METSEPM2225C2DI2RO

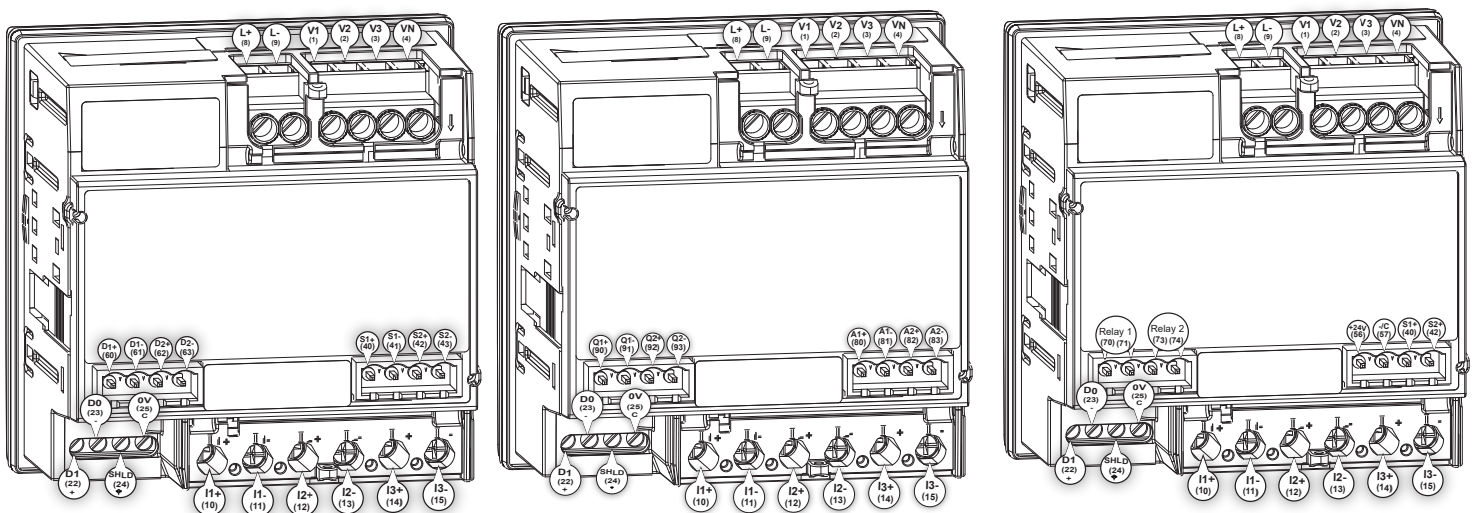

RS-485

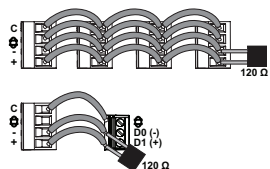

en Straight-line topology only. Loop or ring topology is not supported.
 Note: Resistor is an optional accessory that you can order separately. To terminate a series, it is recommended to use a 120 Ω / 0.5 W resistor.

zh 仅限直线拓扑图。不支持环形拓扑。
 注：电阻为可选件，可以单独订购。要端接该系列产品，建议使用 120 Ω / 0.5 W 电阻。

5 Wiring / 接线

V1, V2, V3, VN	0.20 - 5.26 mm ² (24 - 10 AWG)	0.31 - 0.35 in (8 - 9 mm)	0.5 - 0.6 N·m (4.4 - 5.3 in·lb)	⊘ M3.5	
L+, L-	0.20 - 5.26 mm ² (24 - 10 AWG)	0.31 - 0.35 in (8 - 9 mm)	0.5 - 0.6 N·m (4.4 - 5.3 in·lb)	⊘ M3.5	
I ₁₊ , I ₁₋ , I ₂₊ , I ₂₋ , I ₃₊ , I ₃₋	0.82 - 3.31 mm ² (18 - 12 AWG)		0.7 - 0.8 N·m (6.0 - 7.0 in·lb)	⊘ PH2	
+, -, Ⓢ, C	0.13 - 1.30 mm ² (26 - 16 AWG)	0.24 in (6 mm)	0.5 - 0.6 N·m (4.4 - 5.3 in·lb)	⊘ M3	
Digital I/O 数字 I/O	S1+, S1-, S2+, S2- D1+, D1-, D2+, D2-	0.20 - 3.31 mm ² (24 - 12 AWG)	0.28 in (7 mm)	0.5 - 0.6 N·m (4.4 - 5.3 in·lb)	⊘ M3
Analog I/O 模拟 I/O	A1+, A1-, A2+, A2- Q1+, Q1-, Q2+, Q2-				
Digital Input / Relay 数字输入 / 继电器	+24V, -/C, S1+, S2+ Relay 1, Relay 2				

	Potential Transformer / 电压互感器	Current Transformer / 电流互感器
IEC		
ANSI		

en **A** 250 mA fuses / circuit breaker #

B Shorting block #

C PT primary fuses and disconnect switch #

not supplied

* indicates wiring for a balanced system

Clearly label the device's disconnect circuit mechanism and install it within easy reach of the operator.

The fuses / circuit breakers must be rated for the installation voltage and sized for the available fault current.

Fuse for neutral terminal is required if the source neutral connection is not grounded.

zh **A** 250 mA 熔丝 / 电路断路器 #

B 短接块 #

C PT 一次电路熔丝和隔离开关 #

未配备

* 表示一个平衡系统的接线

清楚标明装置的断路机制，并将其安装在操作员易触及的位置。

熔丝和断路器的额定值必须与设备电压一致，并调整为可能出现的故障电流大小。

如果电源中性线未接地，需要为中性线安装熔丝。



Direct connect maximum voltage / 直连最大电压

UL / IEC	≤ 277 V L-N / 480 V L-L (CAT III)	≤ 277 V L-N / 480 V L-L (CAT III)	≤ 480 V L-L (CAT III)	≤ 480 V L-L (CAT III)	≤ 480 V L-L (CAT III)	≤ 277 V L-N	≤ 277 V L-N / 480 V L-L (CAT III)
	≤ 347 V L-N / 600 V L-L (CAT II)	≤ 347 V L-N / 600 V L-L (CAT II)	≤ 600 V L-L (CAT II)	≤ 600 V L-L (CAT II)	≤ 600 V L-L (CAT II)	≤ 347 V L-N	≤ 347 V L-N / 600 V L-L (CAT II)

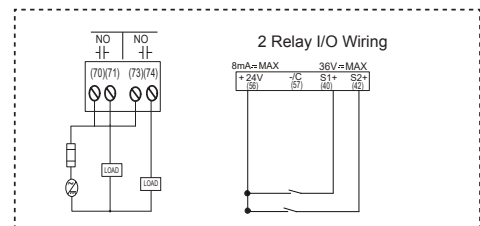
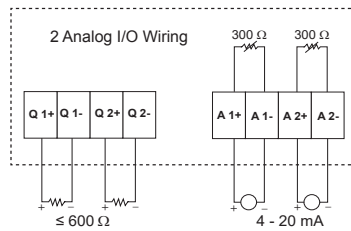
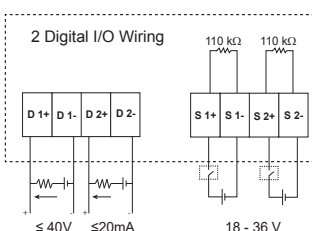

en Whetting voltage should not be used as a power source for other devices. -/c is common for digital status inputs and whetting voltage.

zh 激励电压不应作为其他设备的电源。-/c 是数字 状态输入和激励电压共用的。

1PH

1PH2W LN

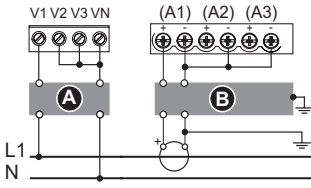

1PH2W LL

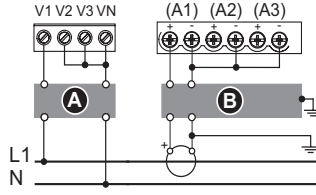

1PH3W LL with N

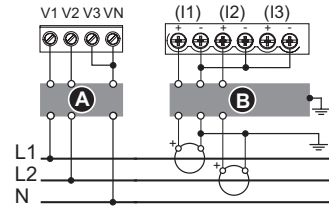

3PH3W

3 CT

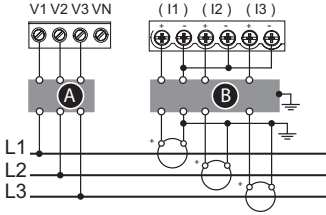

2 CT

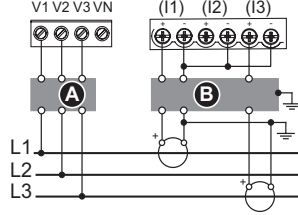

1 CT*

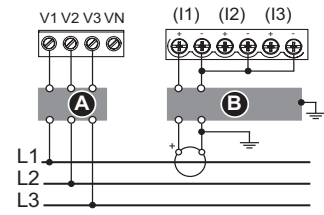

3PH3W

2 VT, 3 CT

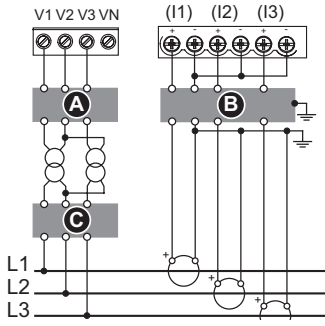

2 VT, 2 CT

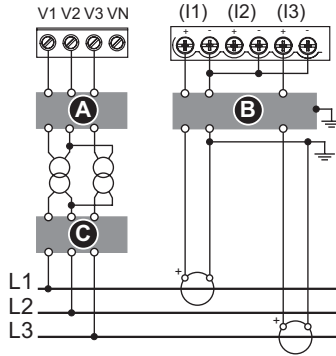

2 VT, 1 CT*

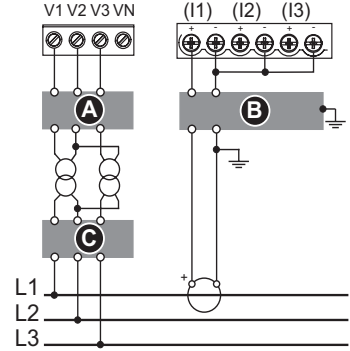

3PH4W

3 CT

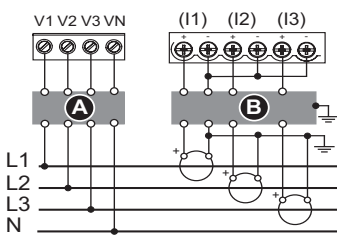

2 CT*

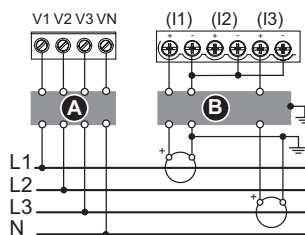

1 CT*

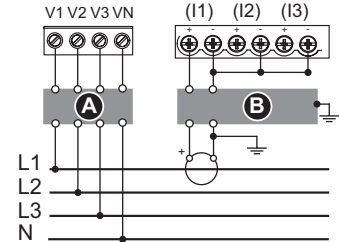

3PH4W

3 VT, 3 CT

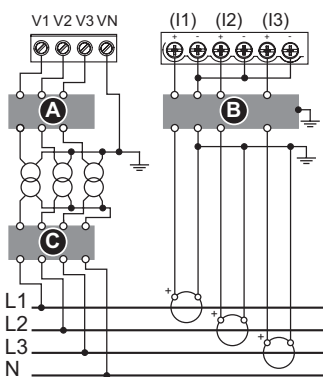

3 VT, 2 CT*

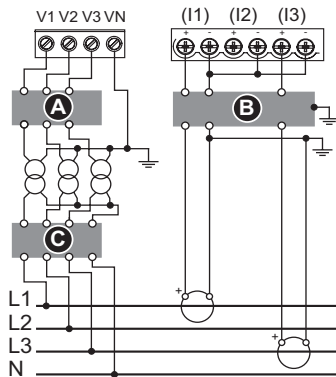

3 VT, 1 CT*

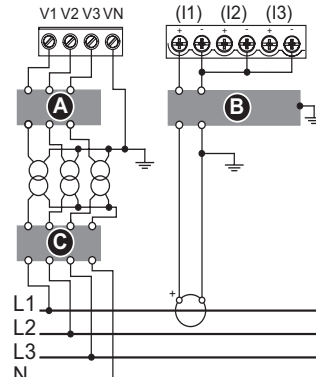

2 VT, 3 CT*

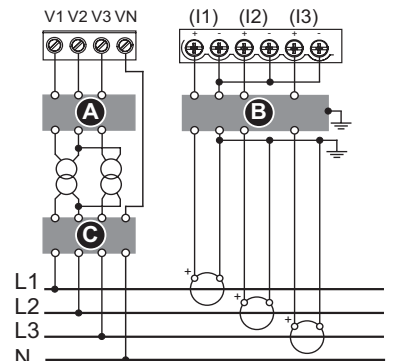

6 Control Power / 控制电源

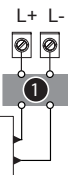

en 1 250 mA fuses

L+ and L- are non-polarized. If using an AC power supply with neutral, connect neutral to the meter's L- terminal. Always use a fuse on L+. Fuse L- when connecting an ungrounded neutral to the control power. If using a control power transformer, fuse both primary and secondary sides of the transformer. The fuses / circuit breakers must be rated for the installation voltage and sized for the available fault current.

AC: 80-277 V L-N ± 10%
DC: 100-277 V ± 10%

zh 1 250 mA 熔丝

L+ 和 L- 是无极性的。如果使用带中性线的交流电源，将中性线连至仪表的 L- 端子。始终在 L+ 上使用熔丝。将未接地中性线连接到控制电源时，请在 L- 上使用熔丝。如果使用控制电源互感器，则在互感器的一次和二次两侧都要使用熔丝。熔丝和断路器的额定值必须与设备电压一致，并调整为可能出现的故障电流大小。

7 Description / 说明

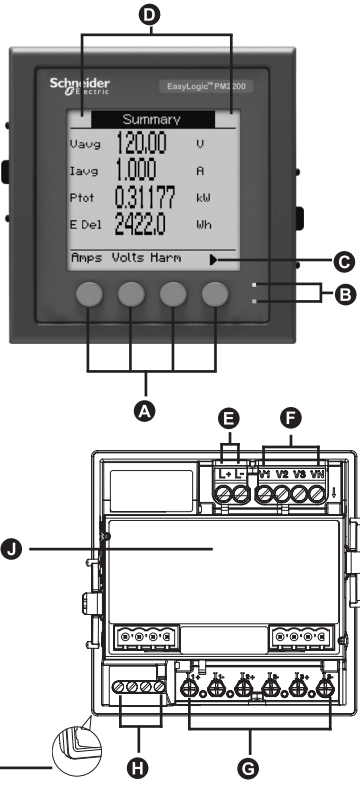

en

- A** Menu selection buttons
- B** LED indicators
- C** Navigation or menu selections:
 - ▲ Exit screen and go up one level
 - ▲ Move cursor up the list of options
 - ▼ Move cursor down and display more options
 - ◀ Move cursor one character to the left
 - ▶ Scroll right and display more menu items
 - + Show the next item in the list, or increase the highlighted value
 - Show the previous item in the list
- D** Maintenance and alarm notification area
- E** Control power
- F** Voltage inputs
- G** Current inputs
- H** RS-485
- I** Gasket
- J** I/O card

zh

- A** 菜单选择按钮
- B** LED 指示灯
- C** 导航或菜单选择:
 - ▲ 退出屏幕并返回上一级
 - ▲ 在选项列表中向上移动光标
 - ▼ 向下移动光标并显示更多选项
 - ◀ 向左移动光标一个字符
 - ▶ 向右滚动并显示更多菜单项
 - + 显示列表中的下一项或增大突出显示的值
 - 显示列表中的前一项
- D** 维护和报警通知区域
- E** 控制电源
- F** 电压输入
- G** 电流输入
- H** RS-485
- I** 衬垫
- J** I/O 卡

8 Basic setup menus / 基本设置菜单

en

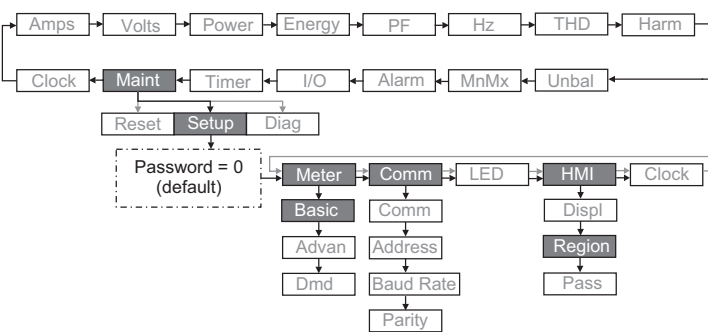

Change the regional settings (if required):

- Navigate to **Maint > Setup > HMI > Region**.
- Use the **Edit** and **+** or **-** buttons to change the displayed **Language, Date Format, Time Format** or **HMI mode**.

Perform basic setup:

- Navigate to **Maint > Setup > Meter > Basic**.
- Edit all the meter parameters to match your power system and electrical wiring.
- Exit and save your settings.

Set up communications:

- Navigate to **Maint > Setup > Comm**.
- Edit all parameters to match your network communications.
- Exit and save your settings.

zh

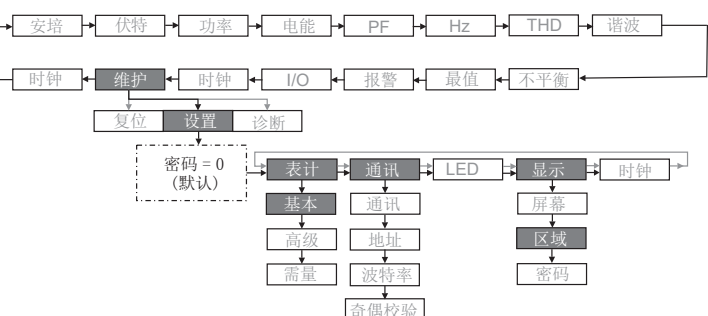

更改区域设置 (如有必要):

- 导航至 **维护 > 设置 > 显示 > 区域**。
- 使用编辑和 **+** 或 **-** 按钮更改显示的语言、日期格式、时间格式或显示模式。

执行基本设置:

- 导航至 **维护 > 设置 > 表计 > 基本**。
- 编辑所有测量仪参数，使其与您的电力系统和电气接线相匹配。
- 退出并保存您的设置。

设置通讯:

- 导航至 **维护 > 设置 > 通讯**。
- 编辑所有参数，使其与您的网络通讯相匹配。
- 退出并保存您的设置。

en

**Control power**

- AC: 80-277 V L-N \pm 10%
- AC burden: < 8 VA at 277 V AC L-N
- Frequency: 45-65 Hz
- DC: 100-277 V \pm 10%
- DC burden: \leq 3.3 W at 277 V DC
- Installation category III

AC Voltage inputs

- Measured voltage:
 - 35 - 480 V L-L (20-277 V L-N), cat III
 - 35 - 600 V L-L (20-347 V L-N), cat II
- Nominal frequency: 50/60 Hz
- Permanent overload: 750 V AC L-L
- Impedance: 5 M Ω
- Measurement category III

AC Current inputs

- 1 A or 5 A nominal
- Measured current: 5 mA to 6 A
- Nominal frequency: 50/60 Hz
- Withstand: 12 A continuous
- Impedance: < 0.3 m Ω
- Burden: < 0.024 VA at 6 A
- Suppression current: 5 mA to 99 mA

Digital (Status) Input

- Voltage ratings:
 - ON 18 to 36 V DC
 - OFF 0 to 4 V DC
- Update rate : 1s
- Set up and configuration : Through ION set up software

Digital Output

- Load voltage: \leq 40 V DC
- Load current: \leq 20 mA
- On resistance: \leq 50 Ω
- Update rate : 1s
- Set up and configuration : Through ION set up software

Isolation: 2.5 kV RMS**Environment**

- Temperature:
 - Operating: -10 to 60 °C (14 to 140°F)
 - Storage: -25 to 70 °C (-13 to 158 °F)
- Humidity rating: 5% to 95% RH non-condensing
- Pollution degree: 2
- Altitude: \leq 2000 m (6562 ft) above sea level
- IP54 front display (IEC 60529)
 - IP30 meter body with retainer clip part number- C10003577
 - IP20 meter body with retainer clip part number- C10003279
- For indoor use only
- Not suitable for wet locations

Analog Input

- Measurement scale : 4-20 mA
- Maximum source impedance : >500 Ω
- Update rate : 1s
- Accuracy : 1% of full scale at ambient temp, 0.1%/K for de-rating
- Set up and configuration : Through ION set up software

Analog Output

- Measurement scale : 4-20 mA
- Load impedance : \leq 600 Ω
- Update rate : 1s
- Accuracy : 1% of full scale at ambient temp
- Set up and configuration : Through ION set up software

Relay

- 250 V L-N AC max. / 2A
- 24 V DC / 2A
- Set up and configuration : Through ION set up software

Whetting Output

- 24V DC / 8mA max

zh

**控制电源**

- 交流: 80 至 277 V L-N \pm 10%
- 交流功耗: < 8 VA, 电压为 277 V AC L-N 时
- 频率: 45 至 65 Hz
- 直流: 100 至 277 V \pm 10%
- 直流功耗: \leq 3.3 W, 电压为 277 V DC 时
- 安装类别 III

交流电压输入

- 测量电压:
 - 35 至 480 V L-L (20-277 V L-N), 类别 III
 - 35 至 600 V L-L (20-347 V L-N), 类别 II
- 额定频率: 50/60 Hz
- 持久过载: 750 V AC L-L
- 阻抗: 5 M Ω
- 测量类别 III

交流电流输入

- 额定 1 A 或 5 A
- 测量电流: 5 mA 至 6 A
- 额定频率: 50/60 Hz
- 耐受值: 12 A 连续
- 阻抗: < 0.3 m Ω
- 功耗: < 0.024 VA, 电流为 6 A 时
- 抑制电流: 5 mA 至 99 mA

数字 (状态) 输入

- 电压额定值:
 - 开启时 18 至 36 V DC
 - 关闭时 0 至 4 V DC
- 更新频率 : 1s
- 设置和配置 : 通过设置 ION 软件

数字输出

- 负载电压: \leq 40 V DC
- 负载电流: \leq 20 mA
- 开启电阻: \leq 50 Ω
- 更新频率 : 1s
- 设置和配置 : 通过设置 ION 软件

绝缘: 2.5 kV RMS**环境**

- 温度:
 - 运行: -10 至 60 °C
 - 存放: -25 至 70 °C
- 额定湿度: 5% 至 95% RH 无结露
- 污染等级: 2
- 海拔高度: \leq 2000 米
- 前显示屏防护等级 IP54 (IEC 60529)
 - 测量仪壳体防护等级 IP30, 带固定器装夹零件号 - C10003577
 - 测量仪壳体防护等级 IP20, 带固定器安装夹零件号 - C10003279
- 仅限室内使用
- 不适合于潮湿场所

模拟 输入

- 测量范围 : 4-20 mA
- 最大源阻抗 : > 500 Ω
- 更新频率 : 1s
- 精度: 环境温度下为满量程的 1%, 精度降级 0.1%/K
- 设置和配置 : 通过设置 ION 软件

模拟 输出

- 范围 : 4-20 mA
- 负载阻抗 : \leq 600 Ω
- 更新频率 : 1s
- 精度: 环境温度下为满量程的 1%
- 设置和配置 : 通过设置 ION 软件

继电器

- 最大 250 V L-N AC / 2A
- 24 V DC / 2A
- 设置和配置 : 通过设置 ION 软件

激励输出

- 24 V DC / 8mA 最大值

China ROHS Certificate

The "Administrative Measures for the Restriction of Hazardous Substances in Electric Appliance and Electronic Products" requires this document to be shipped with all PM2000 products to the People's Republic of China. Purchasers in other countries may disregard.

Les "Administrative Measures for the Restriction of Hazardous Substances in Electric Appliances and Electronic Products" exige que ce document soit transporté avec tous les produits de PM2000 en République Populaire de Chine. Les acheteurs des autres pays peuvent le négliger.

Las "Administrative Measures for the Restriction of Hazardous Substances in Electric Appliances and Electronic Products" requiere que este documento sea enviado con todos los productos PM2000 a la República Popular de China. Los usuarios en otros países pueden ignorar este documento.

Product/ Produit/ Producto: EasyLogic™ PM2225
(METSEPM2225CL05, METSEPM2225C2AI2AO, METSEPM2225C2DI2RO)



产品系列: 电力量度器仪及配件

部件名称 Part Name	产品中有毒有害物质或元素的名称及含量 Hazardous Substances					
	铅 (Pb)	汞 (Hg)	镉 (Cd)	六价铬 (Cr(VI))	多溴联苯 (PBB)	多溴二苯醚 (PBDE)
金属部件 Metal parts	O	O	O	O	O	O
塑料部件 Plastic parts	O	O	O	O	O	O
电子线路板 PCBA	x	O	O	O	O	O

本表格依据 SJ/T11364 的规定编制。

O = 表示该有毒有害物质在该部件所有均质材料中的含量均在 SJ/T11363-2006 标准规定的限量要求以下。
X = 表示该有毒有害物质至少在该部件的某一均质材料中的含量超出 SJ/T11363-2006 标准规定的限量求。

This table is made according to SJ/T 11364.

O: indicates that the concentration of hazardous substance in all of the homogeneous materials for this part is below the limit as stipulated in GB/T 26572.

X: indicates that concentration of hazardous substance in at least one of the homogeneous materials used for this part is above the limit as stipulated in GB/T 26572.

Notices / 注意

en Read these instructions carefully and look at the equipment to become familiar with the device before trying to install, operate, service or maintain it.

Electrical equipment should be installed, operated, serviced and maintained only by qualified personnel. No responsibility is assumed by Schneider Electric for any consequences arising out of the use of this material. A qualified person is one who has skills and knowledge related to the construction, installation, and operation of electrical equipment and has received safety training to recognize and avoid the hazards involved.

EasyLogic and Schneider Electric are trademarks or registered trademarks of Schneider Electric in France, the USA and other countries.

- This product must be installed, connected and used in compliance with prevailing standards and/or installation regulations.
- If this product is used in a manner not specified by the manufacturer, the protection provided by the product may be impaired.
- The safety of any system incorporating this product is the responsibility of the assembler/installer of the system.

As standards, specifications and designs change from time to time, always ask for confirmation of the information given in this publication.

zh 在尝试安装、操作、维修或维护该设备之前，务必仔细阅读这些说明，并对照设备查看以熟悉它。

电气设备应仅由经过认证的技术人员进行安装、操作、维护和维修。由于误用本材料而导致的任何后果，Schneider Electric 公司概不负责。经过认证的技术人员是指该人员拥有与电气设施的 架设、安装和操作相关的技能和知识，并且受过安全培训，能够识别和避免所涉及的危险。

EasyLogic 和 Schneider Electric 是 Schneider Electric 公司在法国、美国和其他国家或地区的商标或注册商标。

- 本产品必须按现行标准和/或安装规定进行安装、连接和使用。
- 如果使用本产品的方式不是制造商指定的方式，可能造成产品本身的保护功能受损坏。
- 将本产品纳入其中的任何系统的安全由该系统的组装/安装人员负责。

由于标准、规格和设计会不时改变，请务必对本出版物中所提供资料进行确认。