

FRONT VIEW

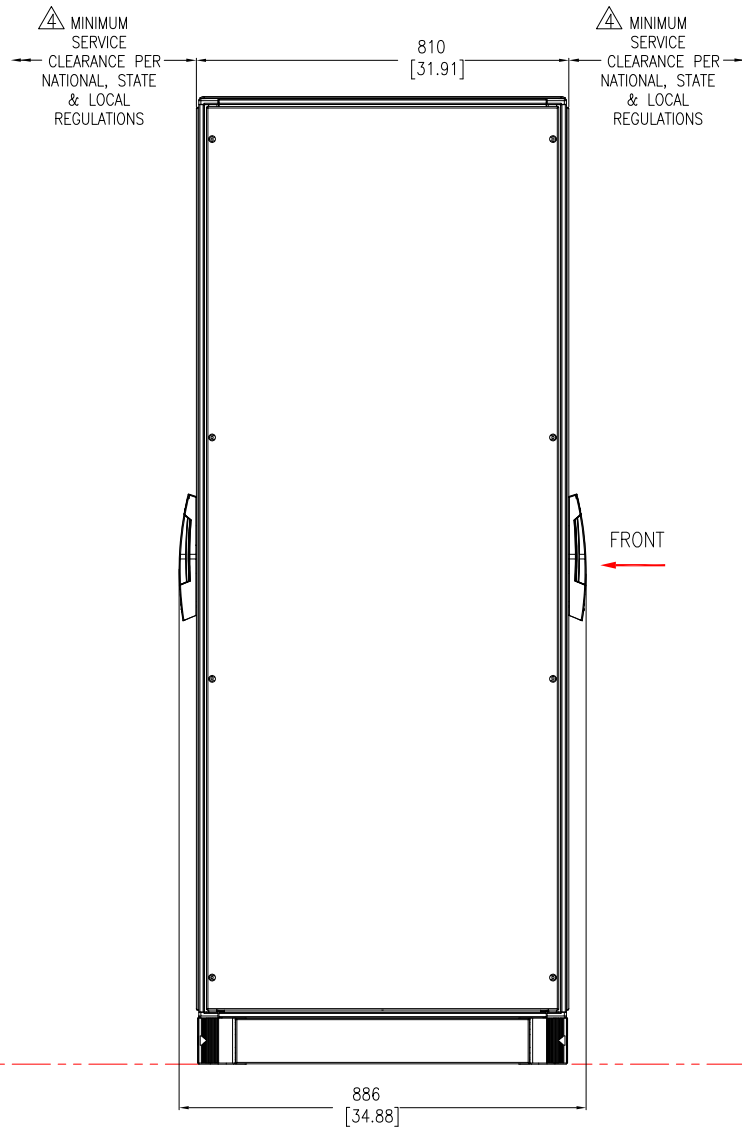

LEFT SIDE VIEW

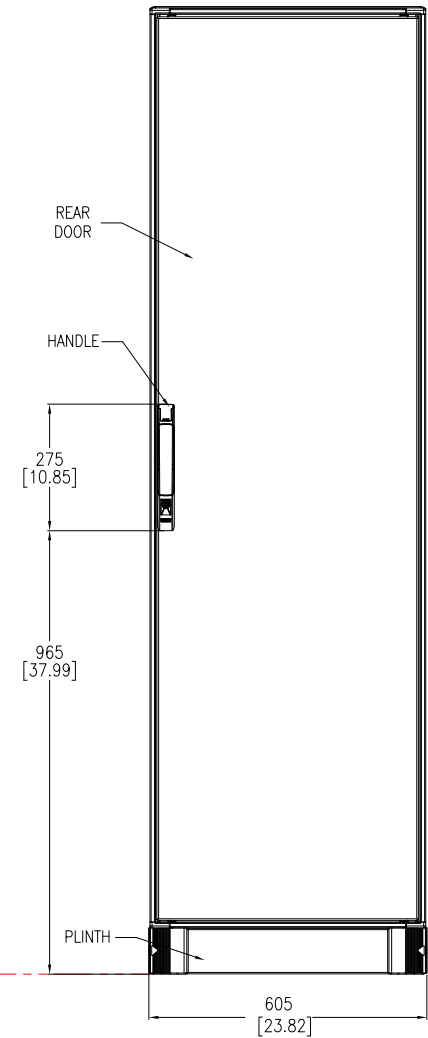

REAR VIEW

NOTES:

1. INSTALLATION SHALL COMPLY WITH ALL APPLICABLE NATIONAL, STATE AND LOCAL ELECTRICAL REGULATIONS.
2. REFER TO PRODUCT DOCUMENTATION FOR ADDITIONAL DETAILS PRIOR TO INSTALLATION AND SITE PREPARATION WORK.
3. ALL DIMENSIONS ARE IN MILLIMETERS [INCHES].
- △ 4. FRONT AND REAR ACCESS REQUIRED FOR SERVICE. MINIMUM REQUIRED FRONT/REAR CLEARANCE IS 36.0 [914].
5. NET WEIGHT OF THE UNIT IS 171kg [377 lb]. STATIC WEIGHT RATING IS 400kg [882 lb].
6. TOP AND BOTTOM CABLE ENTRY USING APPROPRIATE CUSTOMER PROVIDED SOLUTION.
7. PROTECTION CLASS: IP55.
8. COLOR: RAL 7035 GREY.
9. HANDLES ARE SHIPPED LOOSE WITH THE UNIT.

THIS DRAWING AND SPECIFICATIONS HEREIN ARE THE PROPERTY OF SCHNEIDER ELECTRIC AND SHALL NOT BE COPIED, REPRODUCED OR USED IN WHOLE OR IN PART, AS THE BASIS FOR THE MANUFACTURE OR SALE OF ITEMS WITHOUT WRITTEN PERMISSION FROM SCHNEIDER ELECTRIC. THIS DRAWING IS BASED UPON LATEST AVAILABLE INFORMATION AND IS SUBJECT TO CHANGE WITHOUT NOTICE.



TITLE: NetShelter RX 42U Enclosure
600mm Wide x 800mm Deep
FLOOR MOUNT ENCLOSURE
GENERAL ARRANGEMENT

PROJECT: SUBMITTAL DRAWINGS SHEET 1 OF 2

DWG NO: NSYSFRSEDC20680 REV: 1

DRAWN BY: JAYAPRAKASH 20-DEC-21

ENGINEER: FARRUKH SYED 20-DEC-21

APPROVED BY: KEVIN LEMKE 20-DEC-21

FIRST ANGLE PROJECTION

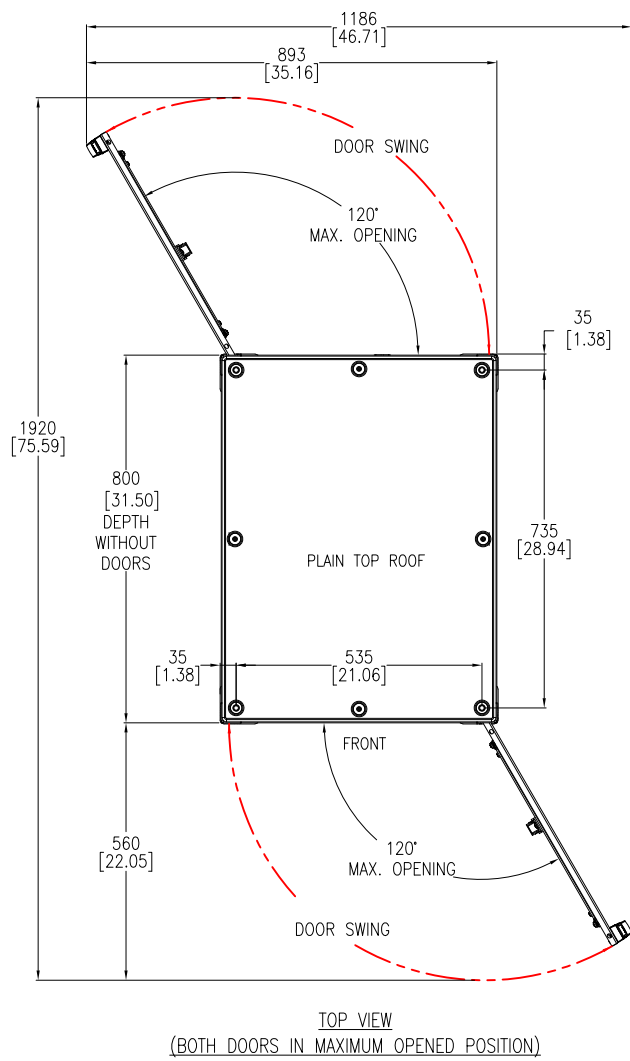

TOP VIEW
(BOTH DOORS IN MAXIMUM OPENED POSITION)

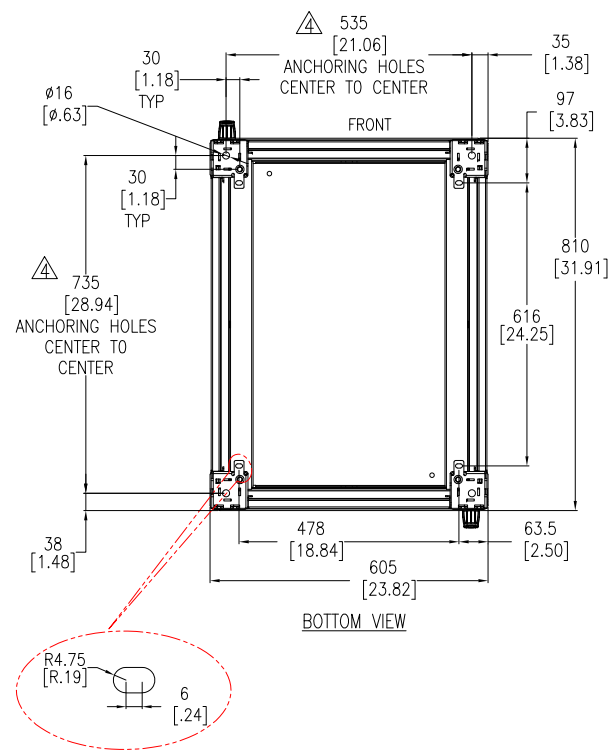

BOTTOM VIEW

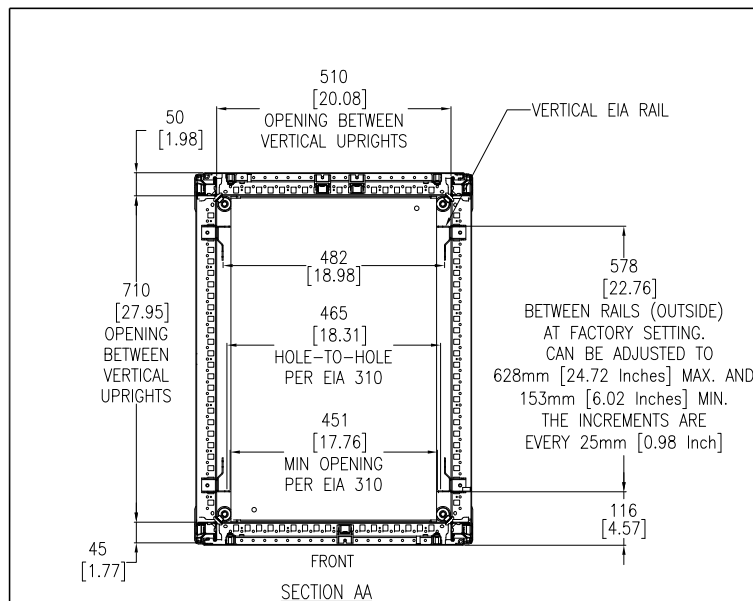

SECTION AA

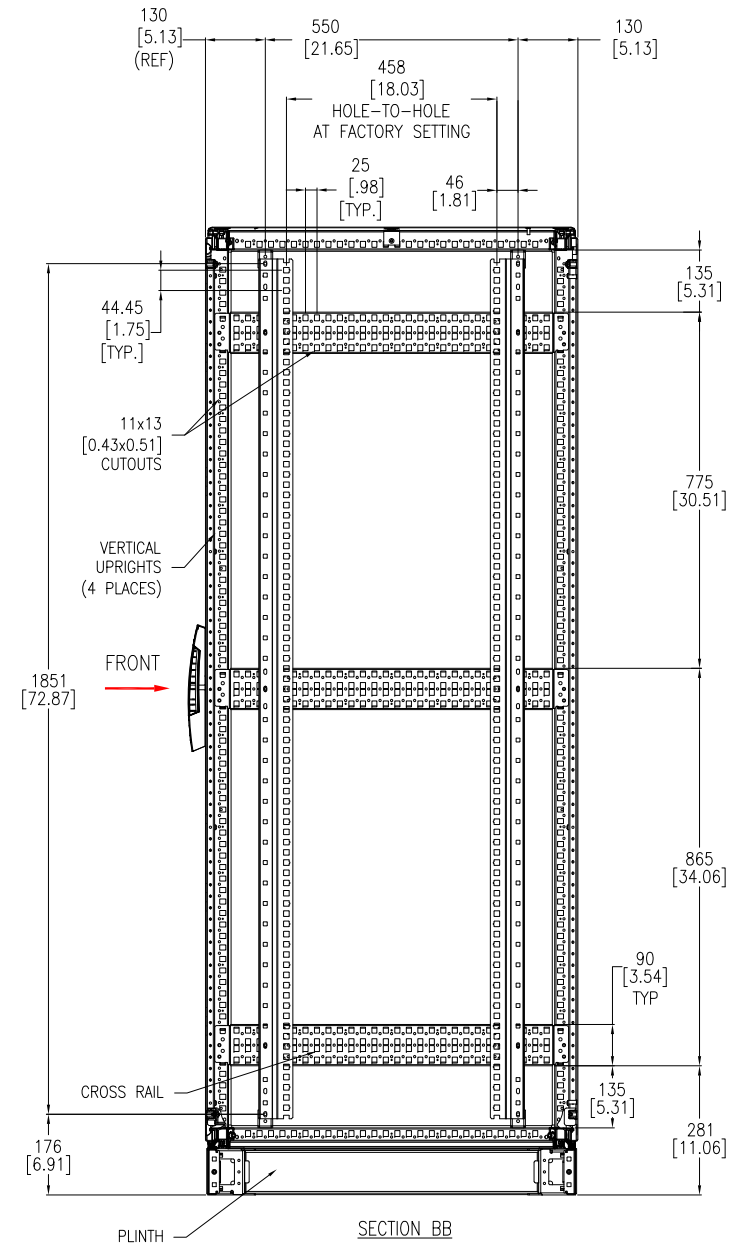

SECTION BB

NOTES:

1. INSTALLATION SHALL COMPLY WITH ALL APPLICABLE NATIONAL, STATE AND LOCAL ELECTRICAL REGULATIONS.
2. REFER TO PRODUCT DOCUMENTATION FOR ADDITIONAL DETAILS PRIOR TO INSTALLATION AND SITE PREPARATION WORK.
3. ALL DIMENSIONS ARE IN MILLIMETERS [INCHES].
4. ANCHORING BOLTS ARE NOT SUPPLIED WITH THE UNIT.

THIS DRAWING AND SPECIFICATIONS HEREIN ARE THE PROPERTY OF SCHNEIDER ELECTRIC AND SHALL NOT BE COPIED, REPRODUCED OR USED IN WHOLE OR IN PART, AS THE BASIS FOR THE MANUFACTURE OR SALE OF ITEMS WITHOUT WRITTEN PERMISSION FROM SCHNEIDER ELECTRIC. THIS DRAWING IS BASED UPON LATEST AVAILABLE INFORMATION AND IS SUBJECT TO CHANGE WITHOUT NOTICE.



TITLE: NetShelter RX 42U Enclosure
600mm Wide x 800mm Deep
FLOOR MOUNT ENCLOSURE
TOP/BOTTOM & SECTION VIEWS

DWG NO: NSYSFRSEDC20680

REV: 2

DRAWN BY: JAYAPRAKASH 22-AUG-22

FIRST

ENGINEER: FARRUKH SYED 23-AUG-22

ANGLE

APPROVED BY: KEVIN LEMKE 23-AUG-22

PROJECTION

PROJECT: SUBMITTAL DRAWINGS SHEET 2 OF 2