

- NOTES:**
1. INSTALLATION SHALL COMPLY WITH ALL APPLICABLE NATIONAL, STATE AND LOCAL ELECTRICAL REGULATIONS.
  2. REFER TO PRODUCT DOCUMENTATION FOR ADDITIONAL DETAILS PRIOR TO INSTALLATION AND SITE PREPARATION WORK.
  3. ALL DIMENSIONS ARE IN MILLIMETERS [INCHES].
  - △4. FRONT AND REAR ACCESS REQUIRED FOR SERVICE. MINIMUM REQUIRED FRONT/REAR CLEARANCE IS 36.0 [914].
  5. NET WEIGHT OF THE UNIT IS 125kg [275.58 lb]. STATIC WEIGHT RATING IS 240kg [529 lb].
  6. TOP AND BOTTOM CABLE ENTRY USING APPROPRIATE CUSTOMER PROVIDED SOLUTION.
  7. PROTECTION CLASS: IP55.
  8. COLOR: RAL 7035 GREY.
  9. HANDLES ARE SHIPPED LOOSE WITH THE UNIT.

THIS DRAWING AND SPECIFICATIONS HEREIN ARE THE PROPERTY OF SCHNEIDER ELECTRIC AND SHALL NOT BE COPIED, REPRODUCED OR USED IN WHOLE OR IN PART, AS THE BASIS FOR THE MANUFACTURE OR SALE OF ITEMS WITHOUT WRITTEN PERMISSION FROM SCHNEIDER ELECTRIC. THIS DRAWING IS BASED UPON LATEST AVAILABLE INFORMATION AND IS SUBJECT TO CHANGE WITHOUT NOTICE.



**TITLE:** NetShelter RX 24U Enclosure  
600mm Wide x 800mm Deep  
FLOOR MOUNT ENCLOSURE  
GENERAL ARRANGEMENT

**PROJECT:** SUBMITTAL DRAWINGS SHEET 1 OF 2

**DWG NO:** NSYSFRSEDC12680

**DRAWN BY:** JAYAPRAKASH 21-DEC-21

**ENGINEER:** FARRUKH SYED 21-DEC-21

**APPROVED BY:** KEVIN LEMKE 21-DEC-21

**REV:** 1

**FIRST ANGLE PROJECTION**

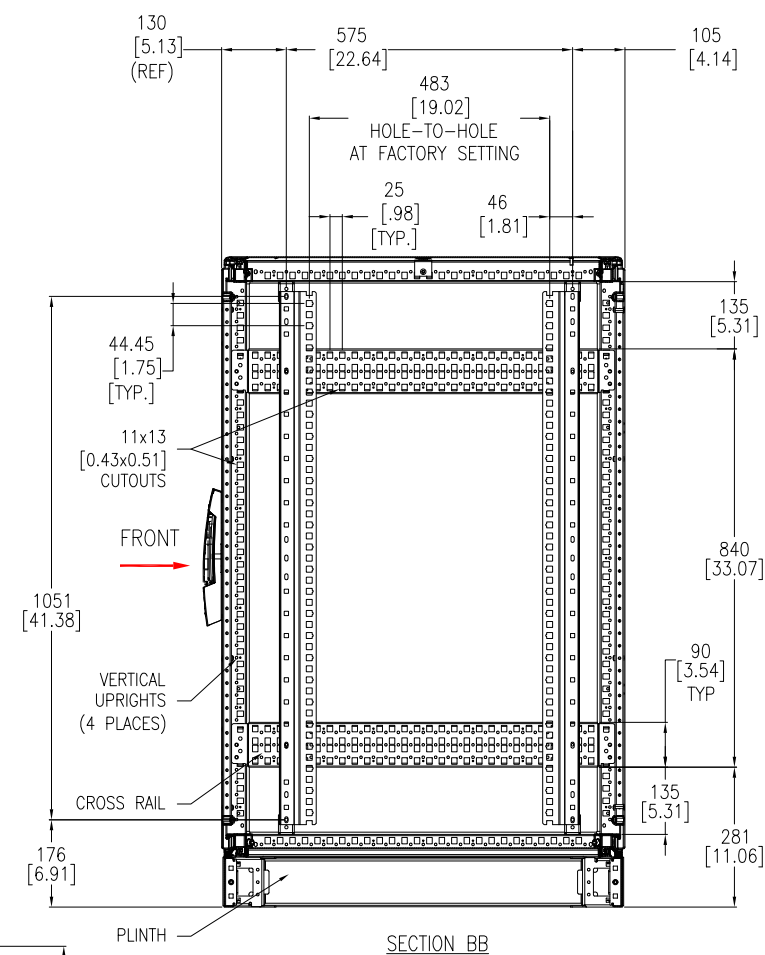
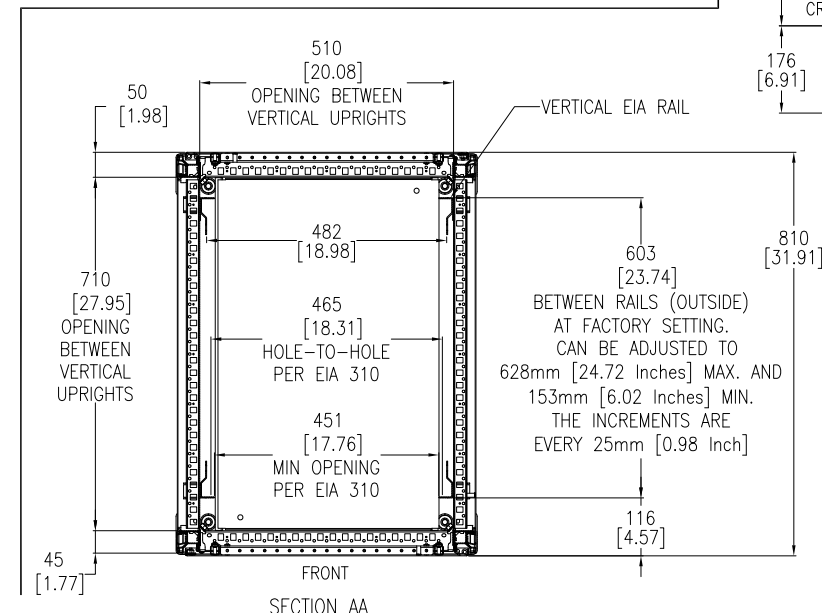
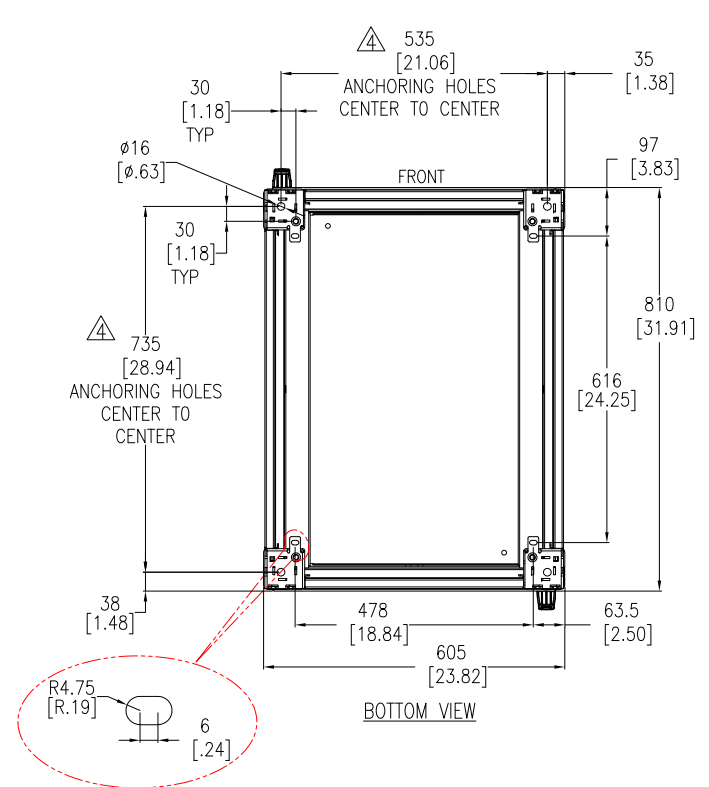
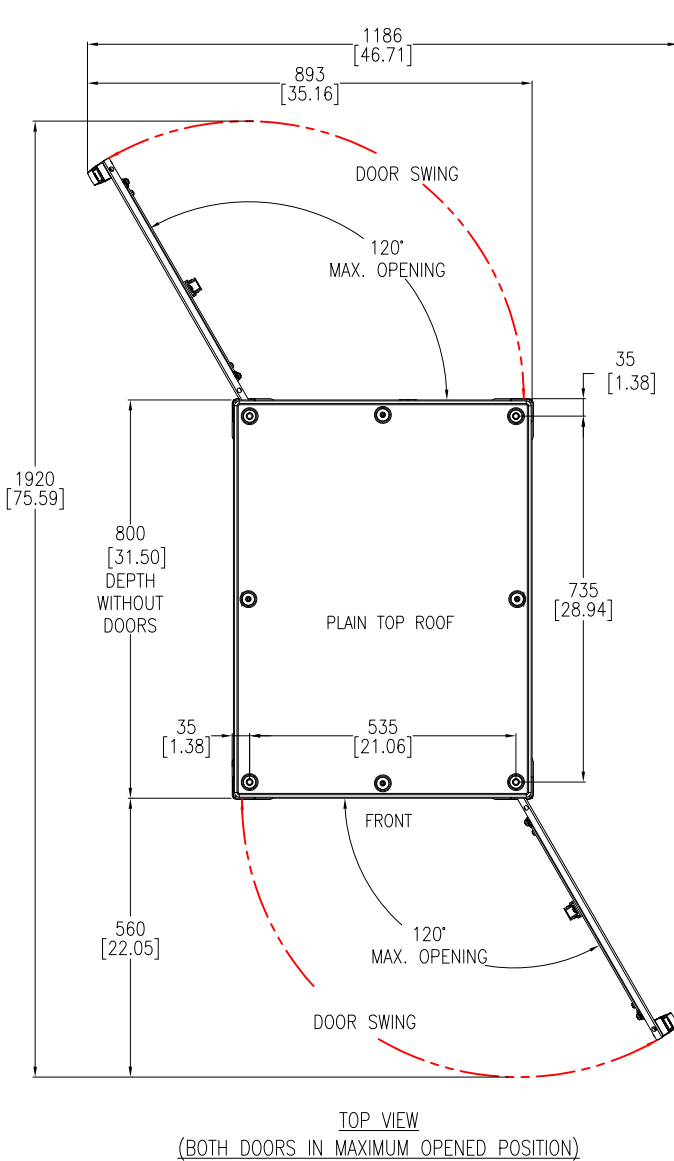

- NOTES:**
1. INSTALLATION SHALL COMPLY WITH ALL APPLICABLE NATIONAL, STATE AND LOCAL ELECTRICAL REGULATIONS.
  2. REFER TO PRODUCT DOCUMENTATION FOR ADDITIONAL DETAILS PRIOR TO INSTALLATION AND SITE PREPARATION WORK.
  3. ALL DIMENSIONS ARE IN MILLIMETERS [INCHES].
  4. ANCHORING BOLTS ARE NOT SUPPLIED WITH THE UNIT.

THIS DRAWING AND SPECIFICATIONS HEREIN ARE THE PROPERTY OF SCHNEIDER ELECTRIC AND SHALL NOT BE COPIED, REPRODUCED OR USED IN WHOLE OR IN PART, AS THE BASIS FOR THE MANUFACTURE OR SALE OF ITEMS WITHOUT WRITTEN PERMISSION FROM SCHNEIDER ELECTRIC. THIS DRAWING IS BASED UPON LATEST AVAILABLE INFORMATION AND IS SUBJECT TO CHANGE WITHOUT NOTICE.



**TITLE:** NetShelter RX 24U Enclosure  
600mm Wide x 800mm Deep  
FLOOR MOUNT ENCLOSURE  
TOP/BOTTOM & SECTION VIEWS

**PROJECT:** SUBMITTAL DRAWINGS **SHEET 2 OF 2**

**DWG NO:** NSYSFRSEDC12680 **REV:** 2

**DRAWN BY:** JAYAPRAKASH **DATE:** 20-MAY-22 **ANGLE:** FIRST

**ENGINEER:** FARRUKH SYED **DATE:** 23-AUG-22 **ANGLE:** ANGLE

**APPROVED BY:** KEVIN LEMKE **DATE:** 23-AUG-22 **PROJECTION:** PROJECTION