



2019 Catalog

PIX

Air insulated switchgear 17.5 kV-50 kA-4000 A
with HVX embedded pole

Medium Voltage Distribution

General contents

Overview	6
----------	---

Range description	20
-------------------	----

Function/module description	30
-----------------------------	----

Components and accessories	38
----------------------------	----

Installation and connection	54
-----------------------------	----

Your requirements

Safety



Reliability



Flexibility and
Ease of Use

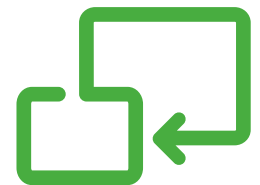

Operator and equipment protection

- Protection against internal arc according to the latest IAC test AFLR, 50 kA, 1s
 - Quick arc flash detection with our sensors to limit the impact of an internal arc
 - Remote operation with motorized switchgear and digital control
 - Thermal monitoring with our TH110 sensors and environmental monitoring with our CL110 sensors, for realtime online information about health status, available 24/7
-

Reliable power supply

- PIX is compliant with IEC standards for metal enclosed switchgear and tested according to IEC 62217-200
 - It is designed for extended use under harsh environment thanks to a vacuum circuit breaker embedded pole and SE-high quality approach
 - User-friendly and ergonomic operator interface to avoid any misuse
 - Vacuum technology for minimal maintenance
-

Flexible & Easy to use

- Efficient tools helping you to save time at every step, from design and deployment to operations:
 - QR-code to provide all product information
 - Cyber secure – compliant with the latest standards
 - Environmental sensors for online health status
 - Front and rear cable access for flexible installations
 - Green premium product to minimize environmental impact
-

Overview

Overview

Field of application	8
Safety	9
Reliability	10
Flexibility and Ease of Use	11
EcoStruxure™ ready solutions	12
Quality assurance	17
Schneider Electric services	18
Green Premium	19

PIX switchgear with vacuum circuit-breaker has been designed for the various operating requirements in public and industrial medium-voltage distribution systems.

Applications

Heavy industry

- Basic material industries
- Chemical industry
- Process engineering
- Water plants



PM106267

Oil&Gas

- Refineries
- Floating production storage units (FPSO)
- Floating Liquefied natural gas platforms (FLNG)



PM106202

Mining, Minerals, Metal

- Mining
- Steel
- Aluminium



PM106203

Power generation

- Power generation in power supply companies
- Power generation for independant power producers
- HV/MV substations



PM106266

Marine

- Cruisers
- Container ships
- Off-shore platforms
- Navy ships
- LNG ships



PE90958_2

PM108204



Operator protection

- Protection against unintended where all switchgear components are in a complete metal enclosure
- PIX has been type tested for the Internal Arc Classification in accordance with IEC/EN 62271-200, achieving an AFL or AFLR protection
- Different solutions for gas exhaust are available: outside the switchgear room with tunnel, inside the switchgear room with tunnel and gas absorber
- All operations are carried out from the front with the door closed which enables the operator to see the status of the switchgear without exposure
- Mechanical and electrical interlocks have been designed to guide the operator and improve operations. These can be reinforced using key-operated locks or padlocks
- Voltage Presence Indicators (VPIS) are present on the front door of each functional unit: checking the presence of energy of multiple cubicles can be completed in the blink of an eye! Checking voltage has to be done before operating the earth switch
- The operator can operate the switchgear remotely

PM108205



Equipment protection

- PIX includes active protection against an internal arc by fast switching. An internal arc limiter quickly detects an internal arc and switches off in order to limit the damage to the switchgear and the switchgear housing
- Two systems are available to detect the light caused by an internal arc and to switch off the upstream breaker:
 - VAMP-system with optical sensors
 - Schneider Electric protection relay series "Easergy P3 or P5" with integrated optical sensors

PM108411



Vamp 125

PM108574



Easergy P3

Reliability

A fundamental quality requirement for a global leader



A wealth of experience

- Compliant with IEC standards AC metal enclosed switchgear for rated voltages above 1 kV and up to 52 kV
- More than 50 years of experience in medium voltage switchgear design
- The PIX platform has been installed worldwide in very harsh environments providing electrical distribution



High quality design

- PIX switchgear only uses key Schneider components that are designed in-house: breakers (mechanism, VI bottles), main busbars and contacts, earthing switches, etc.
- Simulation of dielectric strength, temperature rise and internal arc behaviour helps to optimize critical parts
- Design Failure Mode and Effect Analysis (DFMEA) ensures reliable parts



Independant type tests and systematic checks

Design tests

Specific design tests are performed to check behaviour of aging in specific environmental conditions.

Type tests

The electrical and mechanical performance of PIX have been proven successful by comprehensive type tests. These type tests were performed in independent and accredited laboratories in accordance with IEC international standards.

Factory acceptance test

Each PIX functional unit undergoes a systematic routine test during production to verify conformity with the relevant standards and targeted performances.

Flexibility and Ease of Use

Easy operation providing service continuity

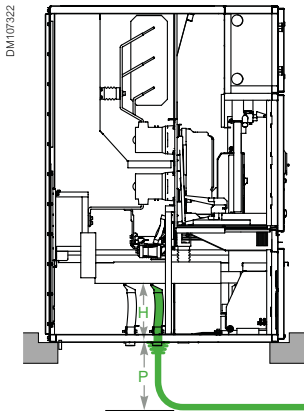

Easy to install

PIX architecture has been designed to accommodate a wide range of installation requirements:

- Up to 8 cables per phase with 630 mm² diameter
- Connections from the rear side
- Connections from the front side
- Connections from the top on request

Easy to operate

- Intuitive single line diagrams on the front door of each functional units provide a clear description of the cubicle components and power flows. This helps to optimize operations
- PIX design allows direct switching of the circuit breaker from the front door to ensure better service continuity



Easy access of technical support

PIX embarks Schneider Electric digital innovation targeting to ease customer life:

- A QR code is on the front plate of each circuit breaker: scanning it provides access to a web page displaying technical information
- Schneider Electric has set up call centers and e-mail contacts in more than 190 countries to provide a rapid response to customer inquiries. Personnel in each country using PIX are trained to provide qualified answers to customer questions
- A service contract for the switchgear room can be provided by the local Schneider Electric service team with packages such as predictive maintenance, preventive maintenance, 24/7 hotline, emergency on-site intervention, and emergency spare part delivery. The availability of the service plan offer varies in different countries

Flexible configurations & compact design

- PIX includes special vacuum circuit breakers for generator switching and contactors for motor switching
- The compact design of PIX helps to reduce the footprint in the installations:
 - width 800 mm/1 000 mm
 - depth 1 600 mm
 - height 2 250 mm/additional height for arc tunnel 520 mm

EcoStruxure™ ready solutions

What is EcoStruxure™?

450 000

EcoStruxure™ systems deployed since 2007 with the support of our 9 000 system integrators.

EcoStruxure™ ready



Efficient asset management
Greater efficiency with **predictive** maintenance helping to reduce downtime



24/7 connectivity
Real-time data **everywhere anytime** to make better-informed decisions



Increased safety
Proven design and experience combined with fast **embedded arc detection** to enhance people's safety and equipment's protection

EcoStruxure is our open, interoperable, IoT-enabled system architecture and platform. EcoStruxure delivers enhanced value around **safety, reliability and efficiency** in operation with **faster and simpler** processes in design and installation.

Turn data into action

EcoStruxure™ architecture lets customers maximize the value of data.

Specifically, it helps them:

- Translate data into actionable intelligence and better business decisions
- Take informed decisions to secure uptime and operational efficiency thanks to real-time control platforms
- Gain visibility to their electrical distribution by measuring, collecting, aggregating, and communicating data

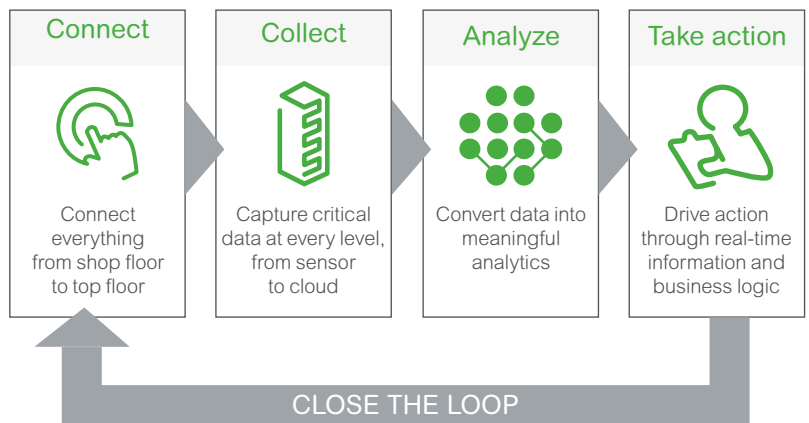

EcoStruxure™
Innovation At Every Level

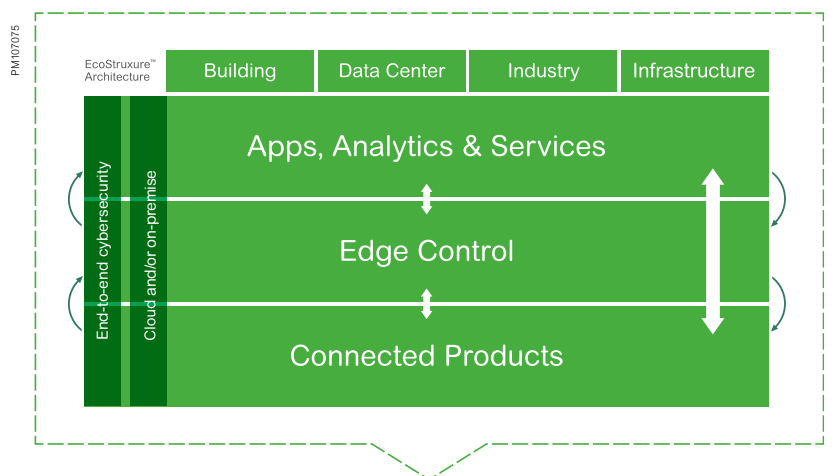

EcoStruxure™ Building | EcoStruxure™ Power | EcoStruxure™ IT | EcoStruxure™ Machine | EcoStruxure™ Plant | EcoStruxure™ Grid

EcoStruxure™ ready solutions

EcoStruxure Grid

Enable nearby control, ensure safety and uptime

All the Schneider Electric protection, metering and control devices can be connected to our Substation monitoring device.

The Human-Machine Interface (HMI) can be installed anywhere within the substation to allow local control and monitoring, independent of any external systems.

The monitoring information and control functions can be scaled to the needs of each customer.

Optionally, the Magelis control and monitoring functions can be mirrored on a tablet through Wifi connection thanks to our Vijeo Design Air application. The technician can operate the switchgear remotely, while maintaining visual contact with it.

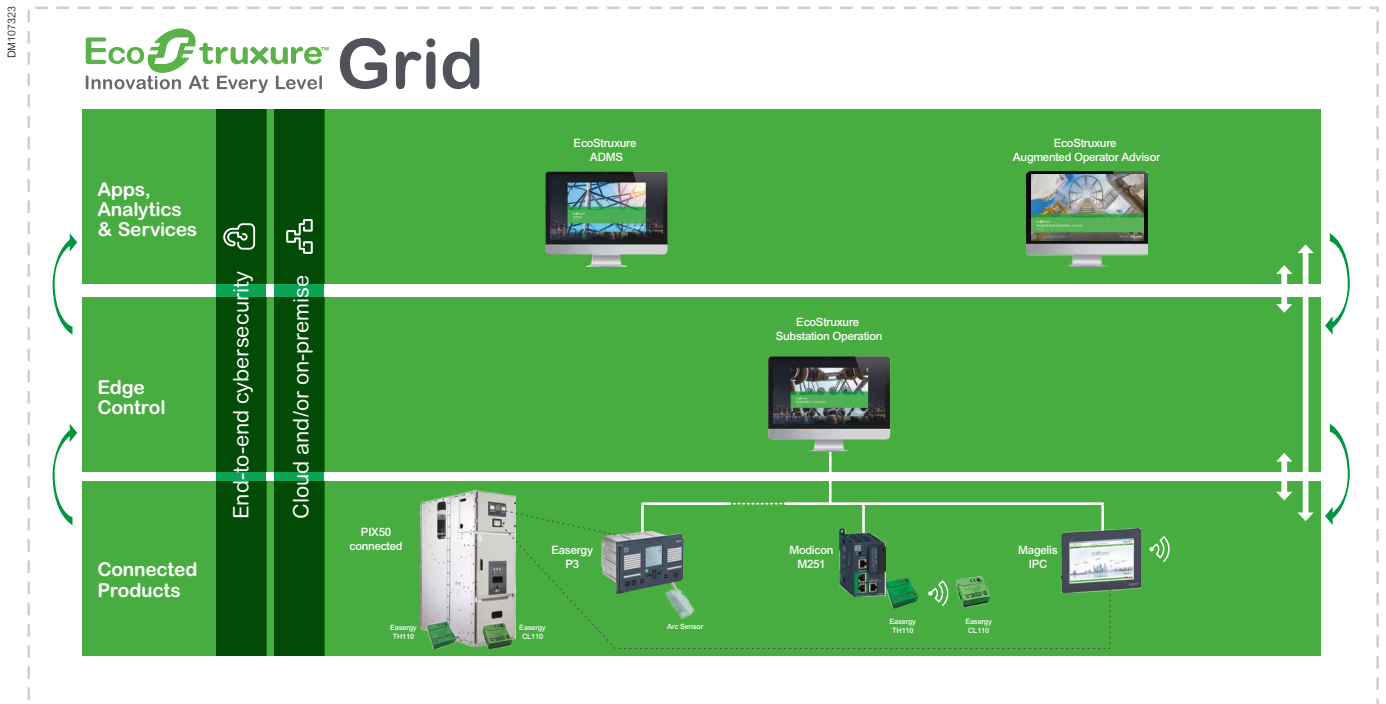
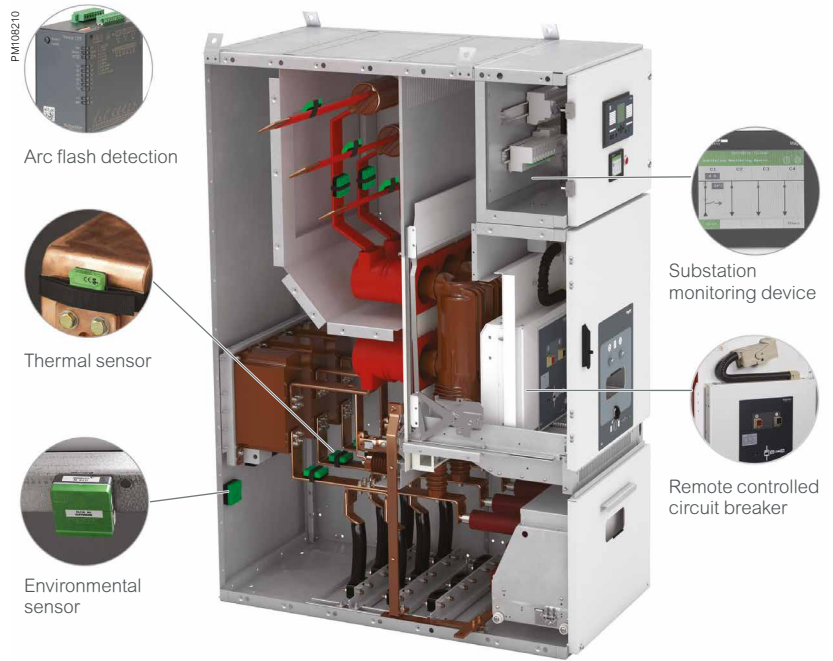

EcoStruxure™ ready solutions

EcoStruxure Power

Power distribution is changing

The world is getting smarter. Every day, it is becoming more decentralized, decarbonized, and digitized. And as your products become more connected, so do you.

With these innovations come increased demand, new regulations, and an opportunity to improve your existing infrastructure.

That's why it's more important than ever to install equipment, software, and services that will **keep everything running smoothly in the present, and prepared for the future.**

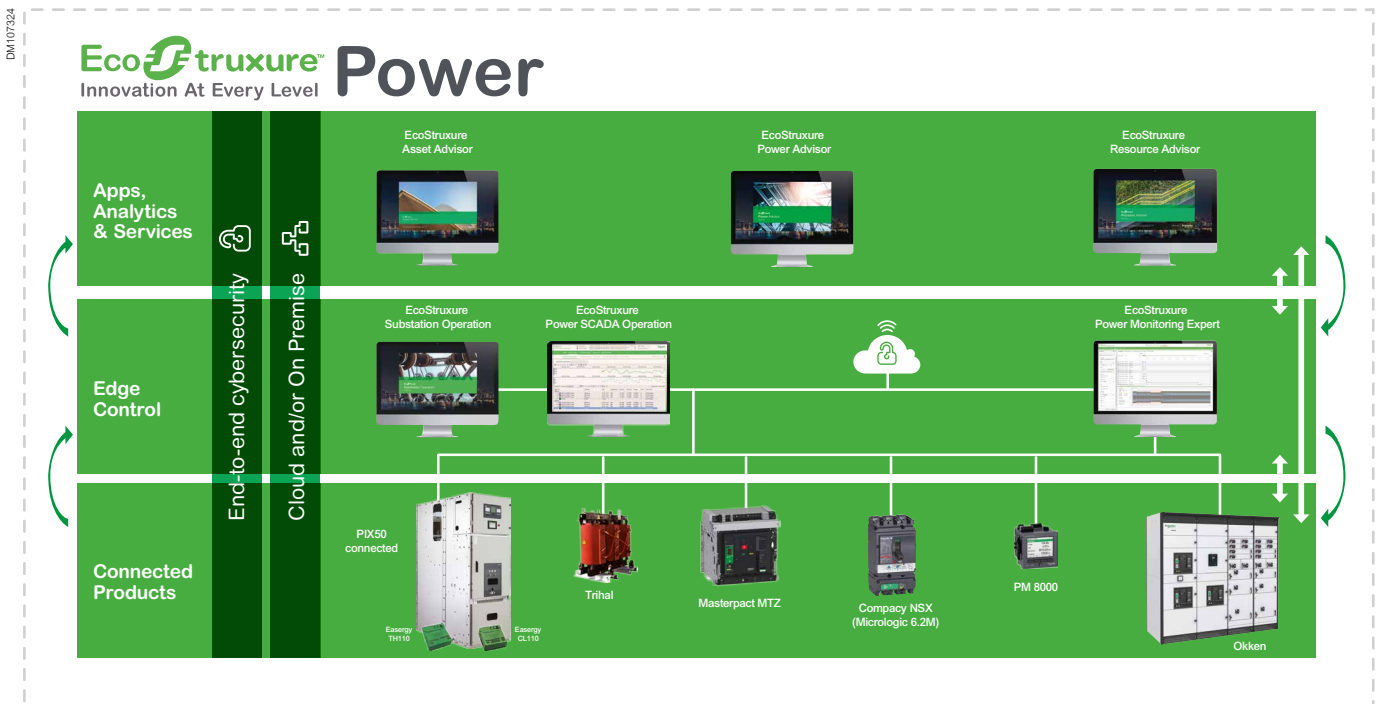

EcoStruxure™ ready solutions

Smart protection for distribution networks



Easergy P3

Easergy P3

The Easergy P3 protection relay family has been developed to cover standard protection needs for industrial and commercial building applications. Thanks to its cost-effective and flexible design, Easergy P3 provides an alternative for various protection applications.

User-friendliness has always been a value of Schneider Electric products, and the Easergy P3 is no exception, with the unique possibility to operate through your smartphone or tablet with the “Easergy SmartApp”.

Rapid setup is achieved with the unique “eSetup Easergy Pro” software which improves usability.



Easergy P5

Easergy P5

Features

The Easergy P5 presents a major step forward for protection relays, bringing the most sought-after features together in one device.

Benefits

- **Industry-leading protection and control functions** with built in **arc-flash protection**, latest cybersecurity and nearby operation with a mobile application
- Go beyond withdrawable with its unique design and industry-leading 10-minute recovery time
- **Easy to install, use and maintain** meaning simple integration and engineering for panel builders, and reduced total cost of ownership for end-users
- **Advanced connectivity** with support for eight communication protocols, including **IEC 61850** compliance
- The Easergy P5 is even more powerful and is connected to its comprehensive digital toolbox, which includes: **EcoStruxure Power Build - Medium Voltage**, **eSetup EasergyPro**, embedded web server, EcoStruxure Power Device app. and mySchneider mobile applications.



Easergy MiCOM range

Easergy MiCOM

Offers scalable levels of functionality and hardware options to suit your protection requirements, and allows you to choose a cost effective solution for your application.

The versatile hardware and common relay management software (Easergy MiCOM S1 Studio) provides simple configuration and installation for different applications.

A standard and simple user interface across the entire range makes Easergy MiCOM ideal in any environment, from the more complex bay level control with mimic, to the most simple LCD display with menu interrogation.

EcoStruxure™ ready solutions

Real-time condition monitoring to optimize asset availability

Easergy CL110 ambient monitoring

The Schneider Electric ambient monitoring system will continuously:

- Help the maintenance manager to monitor ambient moisture and pollution which are harmful to the switchgear
- By automatically calculating the condensation cycle, and combining it with the declared mission profile conditions, the system will recommend maintenance and cleaning frequency adjustment in order to maintain the switchgear in its nominal status

Easergy TH110 thermal monitoring

Easergy TH110 is part of the new generation of wireless smart sensors ensuring the continuous thermal monitoring of all the critical connections made on field allowing to:

- Prevent unscheduled downtimes
- Increase operators and equipments safety
- Optimize and predict maintenance

Thanks to its very compact footprint and its wireless communication, Easergy TH110 has a simple and global installation for a wide range of critical points without impacting on the performance of MV switchgear.

By using ZigBee Green Power communication protocol, Easergy TH110 ensures robust communication that can be used to create interoperable solutions evolving in the age of the Industrial Internet of Things (IIoT).

Easergy TH110 is self powered by the network current and it can ensure high performance providing accurate thermal monitoring.

Characteristics

Power supply	Self powered. Energy harvested from power circuit.
Accuracy	+/- 1°C
Range	-25 °C/+115°C
Wireless communication	ZigBee Green Power 2,4 GHz
Dimension - Weight	31 x 31 x 13 mm - 15 g

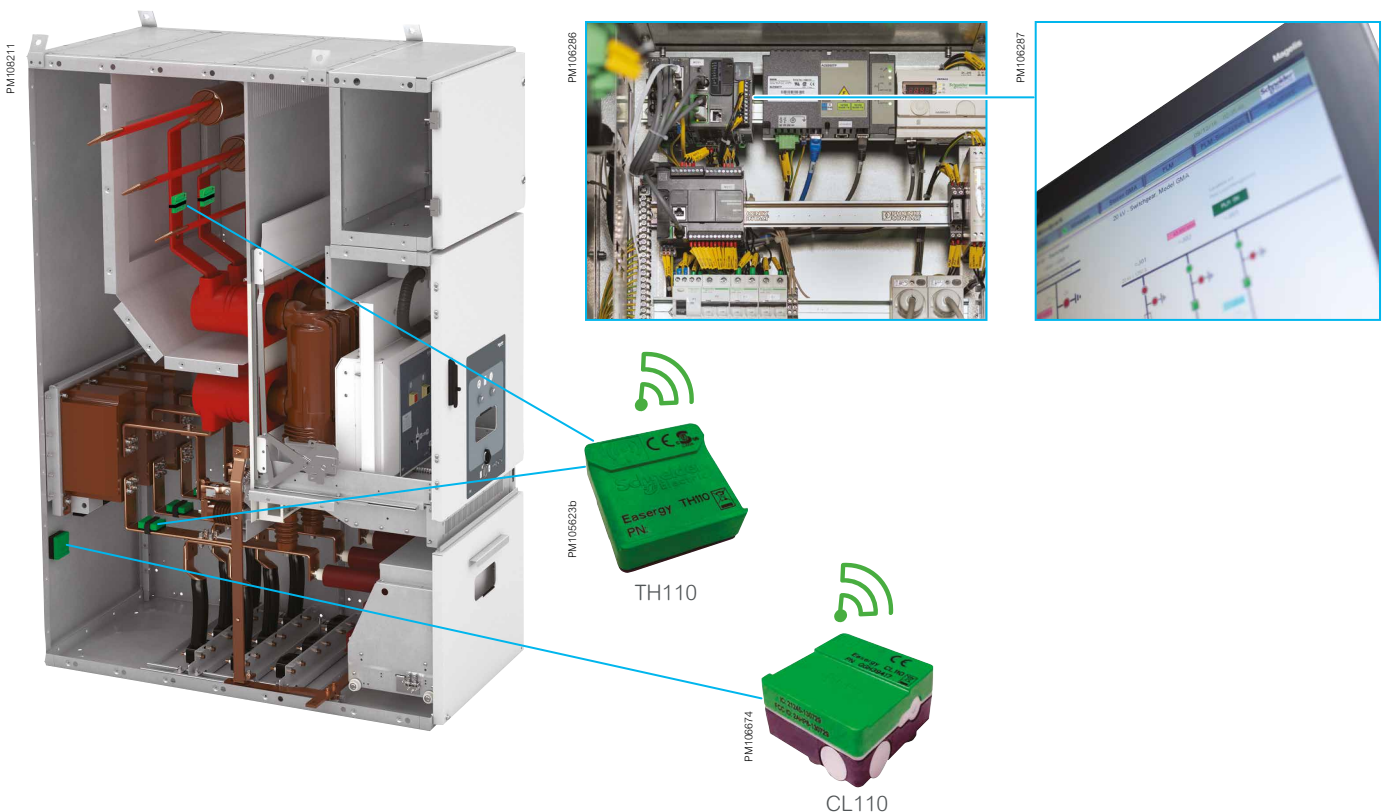

Quality assurance

Quality certified to ISO 9001

The Quality Management System for the development, production, sales and servicing of PIX has been certified in accordance with ISO 9001:2015.

Certified quality: ISO 9001

At Schneider Electric, customer satisfaction is the Number One priority for everybody:

- We find a solution for each of our customers
- We are enthusiastic about our customers; our thinking and actions are clearly customer-oriented
- We encourage and train our staff to quality requirements

Each Schneider Electric production site has an established functional organization which ensures, monitors and improves quality in line with norms and standards.

This process is:

- Uniform across all sites
- Acknowledged by many customers and recognized organizations

Above all, there is a strict Quality Management System which is audited on a regular basis by the international independent certification company Bureau Veritas.



Schneider Electric Services

Greater peace of mind throughout your installation lifecycle

How can you cut costs and improve performance at the same time?

When it comes to your electrical distribution infrastructure, the answer is straightforward: get professional expertise.

Lifecycle services

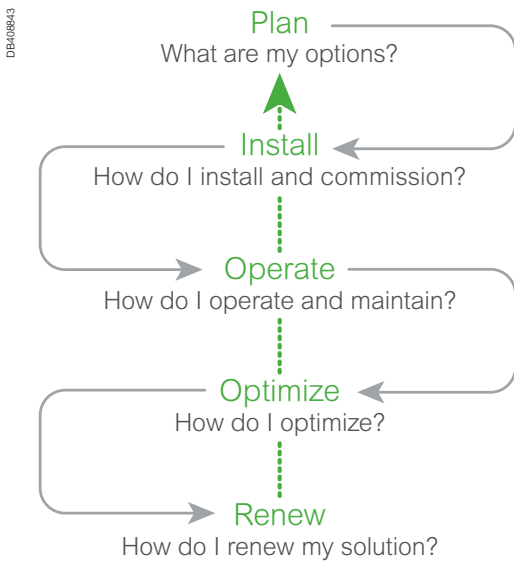

When it comes to your electrical distribution installation, we can help you:

- Mitigate risk and limit downtime
- Keep equipment up to date and extend lifespan
- Cut costs and increase savings
- Improve your return on investment

CONTACT US!

<https://www.schneider-electric.com/en/work/services/>

Plan

Schneider Electric helps you plan the full design and execution of your solution, looking at how to make your process more dependable and optimize time:

- **Technical feasibility studies:** Design a solution in your environment
- **Preliminary design:** Accelerate turnaround time to reach a final solution design

Install

Schneider Electric will help you to install more efficient, more reliable solutions based on your plans.

- **Project management:** Complete your projects on time and within budget
- **Commissioning:** Ensure your actual performance matches the design, through on-site testing and commissioning, tools, and procedures

Operate

Schneider Electric helps you maximize your installation uptime and control your capital expenditures through its service offering.

- **Asset operation solutions:** Provide the information you need to enhance installation performance, and optimize asset maintenance and investment
- **Advantage service plans:** Customize service plans that include preventive, predictive, and corrective maintenance
- **On-site maintenance services:** Deliver extensive knowledge and experience in electrical distribution maintenance
- **Spare parts management:** Ensure availability of spare parts and an optimized maintenance budget for your spare parts
- **Technical training:** Build necessary skills and competencies to properly operate your installations

Optimize

Schneider Electric proposes recommendations to help with availability, reliability, and quality.

- **MP4 electrical assessment:** Define an improvement and risk management program

Renew

Schneider Electric's solutions extend the original life of your system, while providing upgrades.



Green Premium™

An industry leading portfolio of offers delivering sustainable value



More than 75% of our product sales offer superior transparency on the material content, regulatory information and environmental impact of our products:

- RoHS compliance
- REACH substance information
- Industry leading # of PEP's*
- Circularity instructions



Discover what we mean by green
Check your products!

The Green Premium program stands for our commitment to deliver customer valued sustainable performance. It has been upgraded with recognized environmental claims and extended to cover all offers including Products, Services and Solutions.

CO₂ and P&L impact through... Resource Performance

Green Premium brings improved resource efficiency throughout an asset's lifecycle. This includes efficient use of energy and natural resources, along with the minimization of CO₂ emissions.

Cost of ownership optimization through... Circular Performance

We're helping our customers optimize the total cost of ownership of their assets. To do this, we provide IoT-enabled solutions, as well as upgrade, repair, retrofit, and remanufacture services.

Peace of mind through... Well-being Performance

Green Premium products are RoHS and REACH compliant. We're going beyond regulatory compliance with step-by-step substitution of certain materials and substances from our products.

Improved sales through... Differentiation

Green Premium delivers strong value propositions through third-party labels and services. By collaborating with third-party organizations we can support our customers in meeting their sustainability goals such as green building certifications.

*PEP: Product Environmental Profile (i.e. Environmental Product Declaration)

Range description

Range description

Description	22
Technical characteristics	24
Operating conditions & Standards	25
Protection of people	26
Marine applications	27

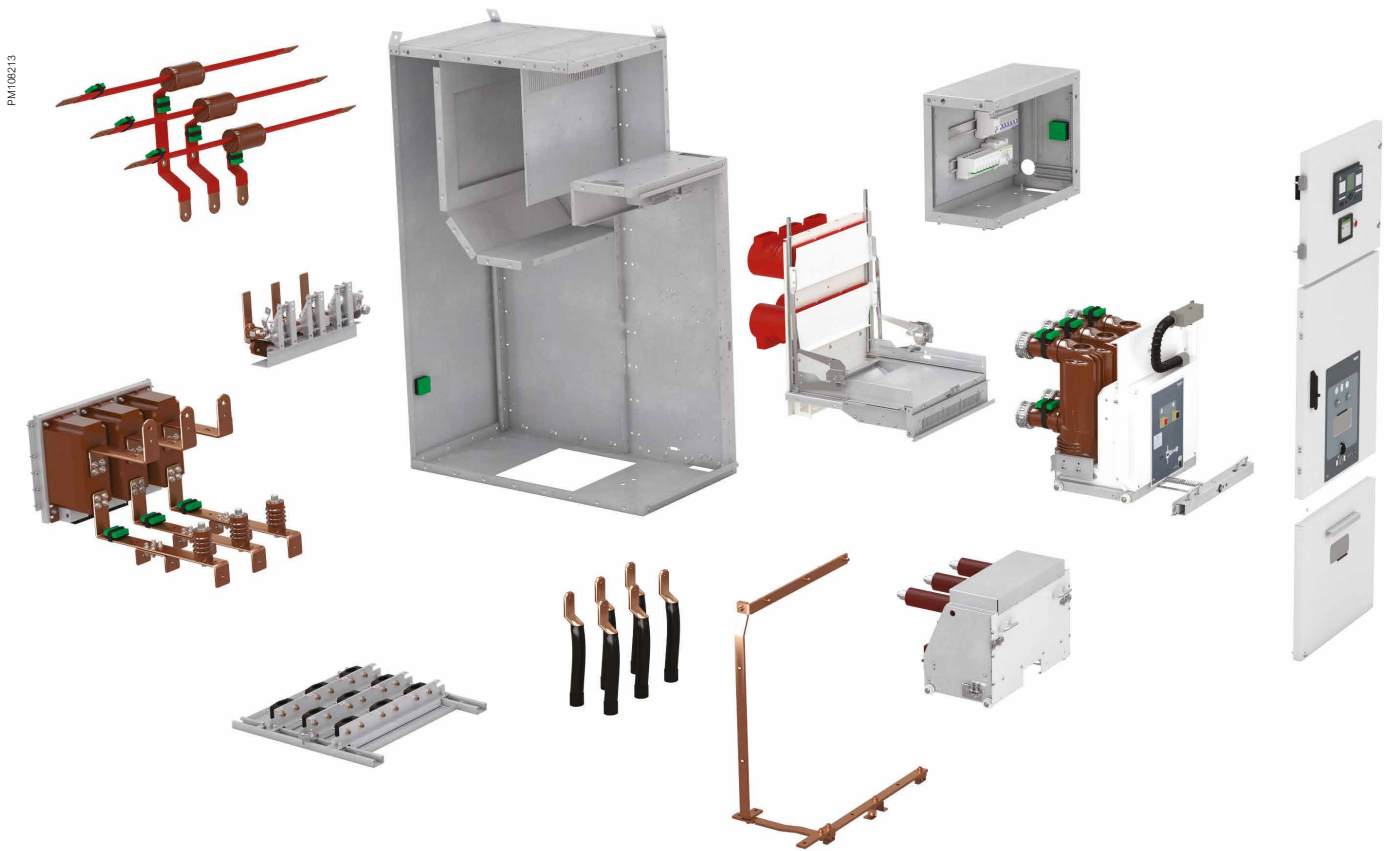

PIX switchboard components

- PIX switchboards consist of several functional units
- Power connections are made between functional units within a switchboard via a single busbar
- The electrical continuity of all metal frames is provided by the connection of each functional unit's earthing busbar to the switchboard's main earthing circuit
- Low voltage wiring trays are provided in the switchboard above the low voltage control cabinets
- LV cables can enter the switchboard through the top or bottom of each functional unit

Description of a functional unit

A functional unit comprises all equipment in the main and auxiliary circuits. Each functional unit combines all the components which are required to fulfil this function:

- The cubicle
- The protection, monitoring and control system
- The withdrawable part

LSC2B (Loss of Service Continuity IEC 62271-200)

This category defines the possibility of keeping other compartments energized (in service) when opening a main circuit compartment.

The cubicle

The high voltage part of the cubicle is separated in 3 compartments using metal partitions (PM class):

- Busbars compartment
- Cables compartment
- Compartment for switching device

Each compartment is connected to earth. These partitions are defined Loss of Service Category class "LSC2B-PM" by IEC standard IEC 62271-200.

When a compartment containing a main circuit is open, the other compartments and/or functional units may remain energized.

The high voltage compartments consists of:

- The metal frame
- The high voltage copper bar connections
- The main switching device (circuit breaker, contactor or disconnecter on a truck)
- The earthing circuit
- The metering devices (current and voltage measuring, voltage indication)

The low voltage auxiliaries and monitoring unit are in a control cabinet separated from the medium voltage section.

The following basic cubicle layouts are offered:

- Incomer or feeder **F**
- Bus section **BS**
- Bus riser **BR**
- Busbar metering and earthing **BME**
- Feeder with contactor **FC**

Normal operating conditions according to IEC62271-200 and IEC 62271-1

Rated voltage	Ur	kV	12	17.5
Rated power frequency withstand voltage - 1 min	U _d	kV	28/42 (1)	38/42 (1)
Rated lightning impulse withstand voltage - peak	U _p	kV	75	95
Rated frequency	f	Hz	50/60	50/60
Rated short circuit breaking current	I _{sc}	kA	50	50
Rated short time withstand circuit	I _p	kA	125 /130 (2)	125 /130 (2)
Rated duration of short circuit	t _k	s	3	3
Rated current busbar, max	I _r	A	4 000 (3)	4 000 (3)
Rated current circuit breaker	I _r	A	1 250	1 250
			2 000	2 000
			2 500	2 500
			3 150	3 150
			4000 (3)	4000 (3)
Rated current contactor	I _r	A	160	n.a.
Rated short time power frequency withstand voltage of auxiliary circuit and control voltage	U _{d aux}	kV	2	2
Internal arc classification and IEC 62271-1				
Internal arc	I _{sc}	kA	50	50
Arc duration	t	s	1	1
Classification			AFLR	AFLR
Degree of protection				
Enclosure			IP4X	IP4X
Between compartments			IP2X/IP3X	IP2X/IP3X

(1) ratings above IEC on request/**(2)** 60 Hz/**(3)** forced cooling



IAC (Internal Arc Classification)

The metal-enclosed switchgear may have different types of accessibility on the various sides of its enclosure.

For identification purposes in terms of the different sides of the enclosure, the following code shall be used (according to the IEC 62271-200 standard):

- **A:** Access to authorized personnel only.

Sides of the enclosure which meet the criteria of the internal arc test:

- **F:** Front side
- **L:** Lateral side
- **R:** Rear side

PIX106862



Standards



The PIX meets the following international standards:

- **IEC 62271-1**: High-voltage switchgear and controlgear: common specifications
- **IEC 62271-200**: AC metal-enclosed switchgear and controlgear for rated voltages above 1 kV and up to and including 52 kA
- **IEC 62271-100**: High-voltage switchgear and controlgear - Alternating current circuit-breakers
- **IEC 62271-106**: High-voltage switchgear and controlgear - Alternating current contactors, contactor-based controllers and motor-starters
- **IEC 60282-1**: High-voltage fuses - Current-limiting fuses
- **IEC 62271-102**: High-voltage switchgear and controlgear - Alternating current disconnectors and earthing switches
- **IEC 60255**: Measuring relays and protection equipment - Common requirements
- **IEC 61869-2**: Instrument transformers - Current transformers
- **IEC 61869-3**: Instrument transformers - Inductive voltage transformers
- **IEC 60044-8**: Instrument transformers - Electronic current transformers

Operating conditions

Normal operating conditions, according to the IEC International Standards listed below, for indoor switchgear.

Ambient air temperature

- Less than or equal to 40°C
- Less than or equal to 35°C on average over 24 hours
- Greater than or equal to -5°C (-25°C on request)

Altitude

- Less than or equal to 1000 m;
- Above 1000 m, a derating coefficient is applied (please consult us)

Atmosphere

- No dust, smoke, or corrosive, or inflammable gas and vapor, or salt

Humidity

- Average relative humidity over a 24 hour period $\leq 95\%$
- Average relative humidity over a 1 month period $\leq 90\%$
- Average vapor pressure over a 24 hour period ≤ 2.2 kPa
- Average vapor pressure over a 1 month period ≤ 1.8 kPa

Specific operating conditions (please consult us)

PIX has been developed to meet the following specific conditions:

- High ambient temperature (possible derating)
- Corrosive atmospheres, vibrations, (possible adaptation)

Storage conditions

In order to retain all of the functional unit's qualities when stored for prolonged periods, we recommend that the equipment is stored in its original packaging, in dry conditions, and sheltered from the sun and rain at a temperature ranging from -25°C up to +55°C.

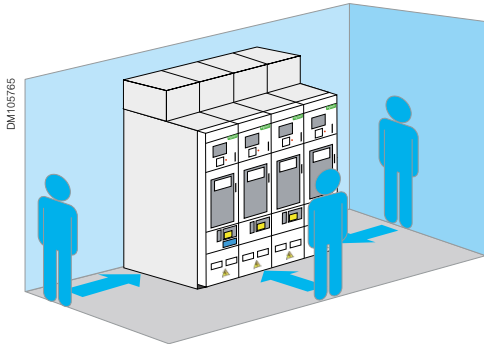

Internal arc classification IAC: accessible sides FL

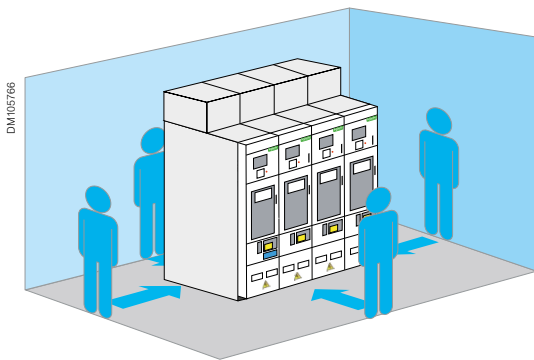

Internal arc classification IAC: accessible sides FLR

IAC Internal Arc Classification

A Accessibility **A**
Restricted to authorized personnel only

F For **f**ront side

L For **l**ateral side

R For **r**ear side

50 kA Arc fault current **50 kA**

1s Arc fault duration **1 s**

Example of PIX with internal arc classification IAC

Internal arc classification

- The internal arc classification IAC provides a verified level of operator safety in the immediate vicinity of the switchgear under normal operating conditions
- The internal arc classification is an option in accordance with IEC 62271-200 and EN 62271-200. It refers to the effect of internal excess pressure on covers, doors, inspection ports, vents etc. Moreover, the thermal effects of the internal arc and its roots on the enclosure and escaping hot gases or incandescent particles are taken into account.
- Metal-enclosed switchgear and controlgear are granted Internal Arc Classification if all the following criteria are met:
 - Criteria No 1: Correctly secured doors and covers do not open
 - Criteria No 2: No fragmentation of the enclosure occurs during the arc fault duration
 - Criteria No 3: Arcing does not cause holes by burning through the classified sides up to a height of 2000 mm
 - Criteria No 4: Indicators do not ignite due to the effect of hot gases
 - Criteria No 5: The enclosure remains connected to the earthing point
- Internal arc classification IAC has been conducted successfully
- As operating and test procedures are performed on the front of the PIX, access via the front and the side walls is standard (IAC A FL)
 - The switching compartment depth can be minimized by wall-mounting the switchgear
 - In this design, the PIX switchgear and controlgear does not require a rear assembly aisle. Access, for example, to the cable compartment or the low-voltage cabinet, is only possible via the front
- If the PIX needs to be installed in the switchgear room with access to the switchgear via the rear side, the switchgear can be provided with additional elements for internal arc classification IAC AFLR (optional)

Marine applications



A Marine version has been developed to meet specific conditions when used on ships or offshore platforms (vibration, inclination, dry heat, damp heat, cold).

This version carries over the electrical and dimensional characteristics of the standard range, adapted to marine requirements:

- PM (partition class) compartmented cubicle (LSC2B type)
- Front access
- Withdrawable circuit breaker
- Easy protection and control chain
- Internal arc withstand
- Thermal + environment diagnosis (optional).

Environmental conditions

Ambient temperature	-5 to +45°C	
Humidity	Over 24 h	95%
	Over 1 month	90%
Vibrations (IEC 60068-2-6)		
Frequency range	Displacement	Acceleration
2 to 13.2 Hz	± 1.0 mm	
13.2 Hz - 100 Hz		0,7 g

Certifications

PIX Marine



Panel

Vacuum CB

Vacuum contactor

Bureau VERITAS (BV)

Bureau VERITAS (BV)

Bureau VERITAS (BV)

For other certifications please contact us

PIX suitable for marine requirements

- Internal arcing withstand is ensured by the use of a tunnel specifically designed for marine applications. Located above the cubicle, it can evacuate gases caused by arcing effects
- A low voltage control cabinet has also been designed to meet the need for using numerous control and monitoring systems and LV components
- Skids are available as an option to group together several cubicles on a platform for improved rigidity
They also facilitate handling and installation of the switchboard.
- Motor starter applications: see PIX with contactor

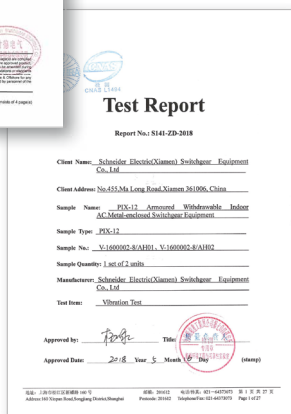



Characteristics for Marine applications

Operating conditions according to IEC62271-200 and IEC 62271-1 and specific environmental conditions for Marine application

Rated voltage	Ur	kV	12
Rated power frequency withstand voltage - 1 min	U _d	kV	28/42 (1)
Rated lightning impulse withstand voltage - peak	U _p	kV	75
Rated frequency	f	Hz	50/60
Rated short circuit breaking current	I _{sc}	kA	50
Rated short circuit withstand current	I _p	kA	125/130 (2)
Rated duration of short circuit	t _k	s	3
Rated current busbar, max	I _r	A	4 000
Rated current circuit breaker	I _r	A	1 250
			2 000
			2 500
			3 150
			4 000 (3)
Rated current contactor	I _r	A	160

(1) ratings above IEC on request/**(2)** 60 Hz/**(3)** forced cooling

PIX Marine design

With Marine specificities (anti-rolling features, handle).
Please contact Schneider Electric for IP42.

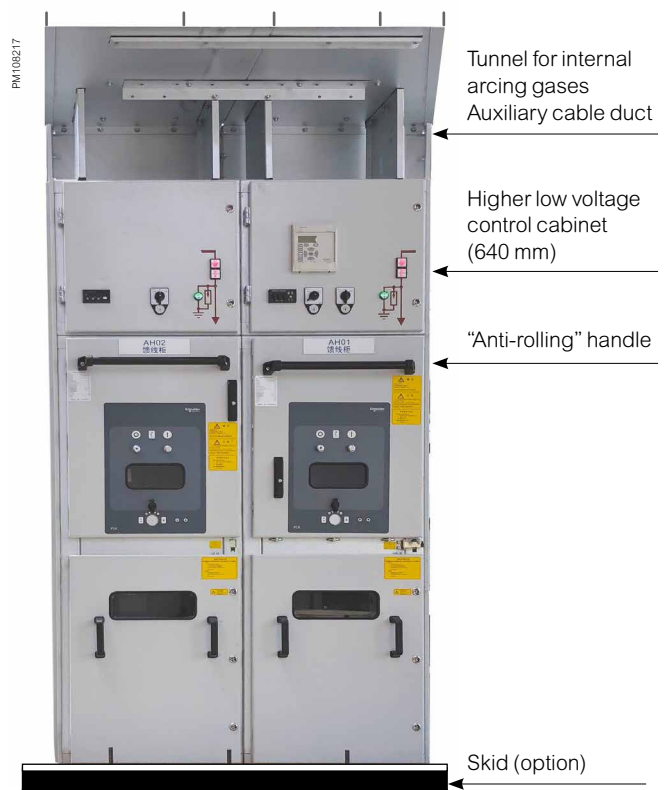

Notes

Function/module description

Function/module description

Functional overview	32
Choice of functional units	32
Feeder/F type cubicles	33
Bus sectioning/BS-BR type cubicles	34
Busbar voltage metering&Busbar earthing/BME type cubicles	35
Feeder with contactor/FC-type cubicles	36

PIX has a comprehensive range of functions to suit all requirements for many applications.

The table below can be used to link requirements to functional units and gives basic information on the general composition of each unit.

Selection guide

For example:

You want to supply power to a transformer:

The chosen solution is a **feeder-transformer-circuit breaker**.

The corresponding functional unit and panel architecture will therefore **be a feeder**.

The main functions of the equipment are shown below.

Additional functions are available upon request to answer specific requirements.

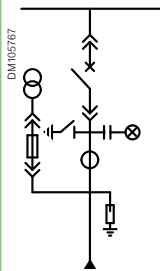
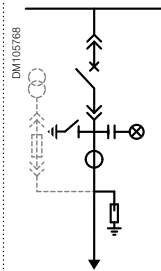
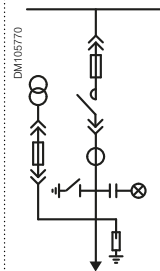
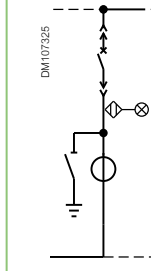
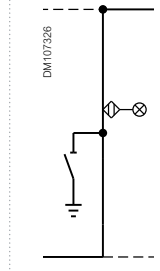
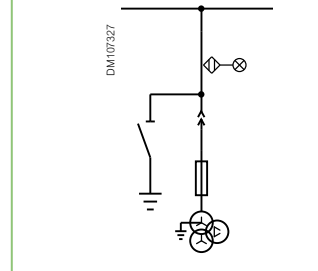
Panel architecture	Feeder			Bus section		Busbar metering & busbar earthing	
Application	Line	Line	Motor	Bus section	Bus riser	Metering & busbar earthing	
	Transformer	Transformer					
	Generator	Motor	Capacitor				
		Capacitor					
Main device	Circuit breaker	Circuit breaker	Contactors with fuse	Circuit breaker		Voltage transformer	Earthing switch
Type of device	HVX	HVX	CVX	HVX		MTX	Earthing switch
Panel function	Incomer	Feeder		Bus sectioning		BB voltage metering	
Panel name, code	F	F	FC	BS	BR	BME	
Single line diagram							

F type cubicles

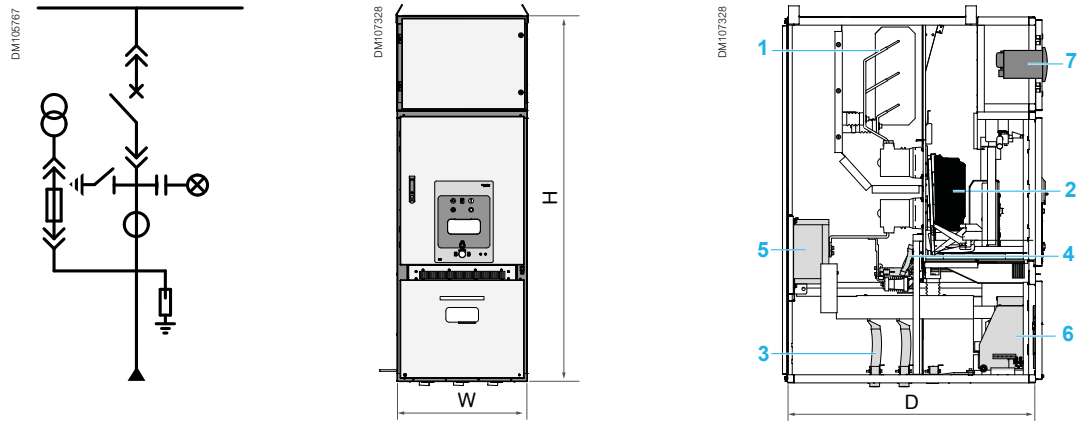

MV devices

- 1 Busbars for cubicle interconnection
- 2 Main switching device
- 3 MV cables accessible from the front
- 4 Earthing switch
- 5 Current transformers
- 6 Voltage Transformers (optionally equipped with withdrawable fuses)

LV control cabinet

- 7 Low voltage auxiliaries and the protection, monitoring and control unit are in a control cabinet which is separated from the medium voltage part

F type characteristics

Feeder	Rated voltage (kV)	Rated short circuit current (kA)	Rated current busbar (A)	Rated current CB (A)	Width (mm)	Depth (mm)	Height (mm)	Height with tunnel (mm)	Weight (kg)
PIX 17-50-1250	17.5	50	Up to 3 150 Up to 4 000*	1 250	800	1 590	2 244	2 764	900
PIX 17-50-2000				2 000					
PIX 17-50-2500				2 500					
PIX 17-50-3150				3 150					
PIX 17-50-4000				4 000*					
					1 000				1 300

* With forced cooling

Functional overview

Bus sectioning/BS-BR type cubicles

The bus sectioning functional unit comprises 2 cubicles mounted side by side (one cubicle equipped with a circuit breaker, the other with a busbar return).

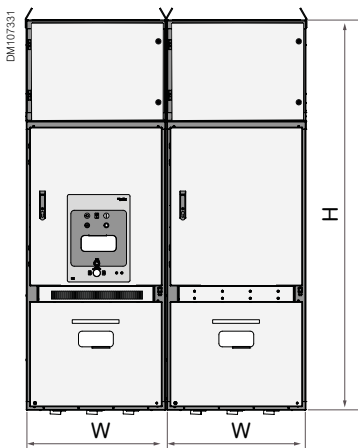
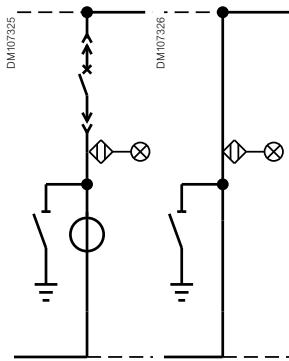

MV devices

- 1 Busbars to connect the bus sectioning functional unit with other switchboard functional units
- 2 Main switching device
- 3 Current sensors

LV control cabinet

- 5 Low voltage auxiliaries and the protection, monitoring and control units are in one control cabinet which is separated from the medium voltage part

BS

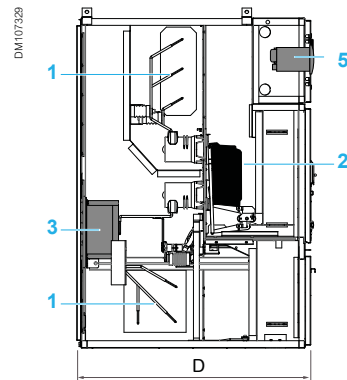

BR

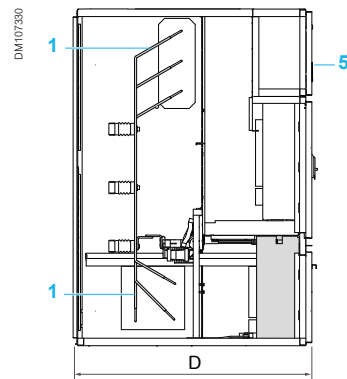

BS-BR type characteristics

Bus section	Rated voltage (kV)	Rated short circuit current (kA)	Rated current busbar (A)	Rated current CB (A)	Width (mm)	Depth (mm)	Height (mm)	Height with tunnel (mm)	Weight (kg)
PIX 17-50-1250	17.5	50	Up to 3 150 Up to 4 000*	1 250	800	1 590	2 244	2 764	900
PIX 17-50-2000				2 000					
PIX 17-50-2500				2 500	1 000				
PIX 17-50-3150				3 150					
PIX 17-50-4000				4 000*					
PIX 17-50-1250	17.5	50	Up to 3 150 Up to 4 000*	1 250	800	1 590	2 244	2 764	700
PIX 17-50-2000				2 000					
PIX 17-50-2500				2 500					1 000
PIX 17-50-3150				3 150					
PIX 17-50-4000				4 000*					

* With forced cooling

Functional overview

Busbar Voltage Metering & Busbar Earthing/ BME type cubicles

MV devices

- 1 Busbars to connect the BME functional unit with other switchboard cubicles
- 2 Earthing switch
- 3 Voltage Transformers (optionally equipped with withdrawable fuses)

LV control cabinet

- 4 Low voltage auxiliaries and the protection, monitoring and control units are in a control cabinet which is separated from the medium voltage part

BME

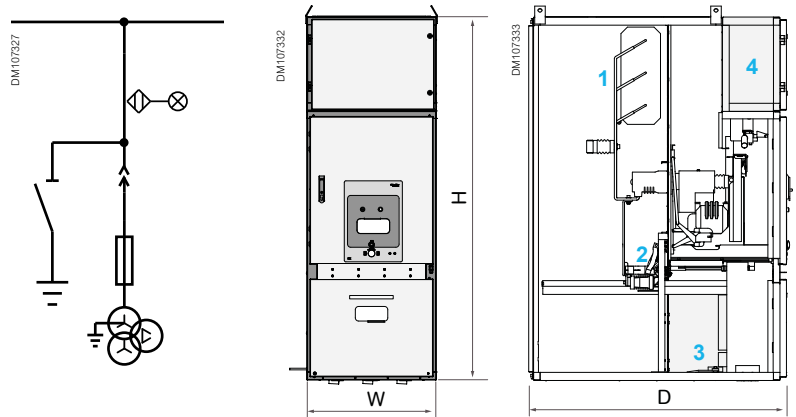

BME type characteristics

BB metering & earthing	Rated voltage (kV)	Rated short circuit current (kA)	Rated current busbar (A)	Main device	Width (mm)	Depth (mm)	Height (mm)	Height with tunnel (mm)	Weight (kg)
PIX 17-50-1250	17.5	50	Up to 3 150 Up to 4 000 *	Metering truck, earthing switch	800	1 590	2 244	2 764	700
PIX 17-50-2500									
PIX 17-50-3150									
PIX 17-50-4000									

* With forced cooling

Functional overview

Feeder with contactor/FC-type cubicles *

With today's large and medium-sized industrial installations using MV motors to drive their plants, the controlgear must provide maximum reliability and minimum down time.

To meet these specific requirements, PIX contactor panel supplements our PIX switchgear range.

Medium voltage motors are one of the biggest consumers of electricity in heavy industry. They can be operated and controlled with a contactor instead of a circuit breaker.

A contactor provides:

- A high number of switching operations up to 3.000.000 cycles
- High efficient protection with fuses
- A slim cubicle design

The PIX contactor panel meets these specific requirements. The design philosophy and operation are similar to the PIX switchgear range helping to reduce training time and to minimize the risk of improper use.

The combination of PIX and the PIX contactor panel provides a complete solution for power plants, process plants and Oil&Gas applications.

MV devices

- 1 Busbars for cubicle interconnection
- 2 Withdrawable fused contactor
- 3 MV connections by cables accessible from the front and rear side
- 4 Earthing switch
- 5 Current Transformers

LV control cabinet

- 6 Low voltage auxiliaries and the protection, monitoring and control unit are in a control cabinet which is separated from the medium voltage part

Options

- Voltage Transformers

PIX contactor panel

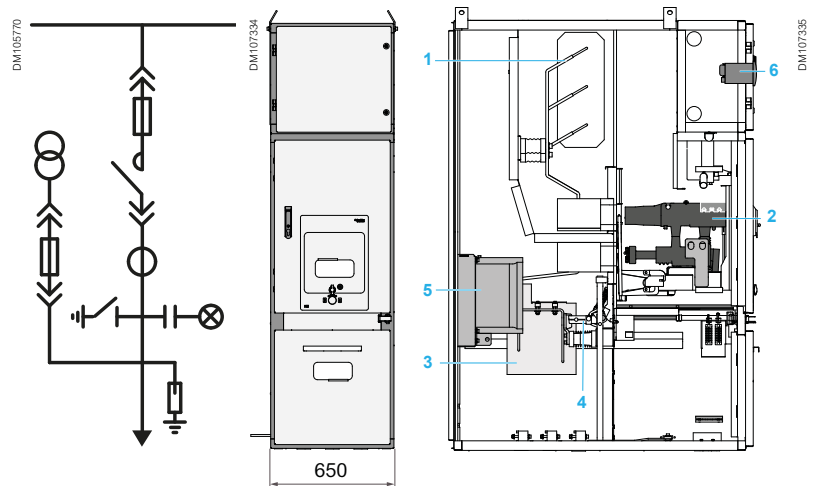

FC type characteristics

Feeder-contactor	Rated voltage (kV)	Rated short circuit current (kA)	Rated current busbar (A)	Rated current contactor (A)	Width (mm)	Depth (mm)	Height (mm)	Height with tunnel (mm)	Weight (kg)
PIX 12-50-160	12	50	1 250	160	650	1590	2 244	2 764	800
PIX 12-50-160			2 000						
PIX 12-50-160			2 500						
PIX 12-50-160			3 150						
PIX 12-50-160			4 000						

* F-C cubicles on request only

Functional overview

Feeder with contactor/FC type cubicles

Characteristics for the PIX contactor cubicle			
Rated voltage	Ur	kV	12
Rated power frequency withstand voltage - 1 min	Ud	kV	28
Rated lightning impulse withstand voltage - peak	Up	kV	75
Rated frequency	f	Hz	50/60
Rated short time withstand current busbars	Ip	kA	150
Rated duration of short circuit	tk	s	3
Rated current busbar, max	Ir	A	4 000
Current transformer type			Block type
Dimensions	H	mm	2 244
	W	mm	650
	D	mm	1 590
Approximate mass		kg	800
Degree of protection	Enclosure		IP3X/4X
	Between compartments		IP2X

Characteristics for PIX contactors			
Rated voltage	Ur	kV	12
Rated short circuit breaking capacity fuses current	Isc	kA	50
Rated current contactor	Ir	A	160
Mechanism			
Electrical endurance	Operations		250 000
Mechanical life with	Operations	Mechanically latched type	300 000
		Electrically latched type	1 000 000

Components and accessories

Components and accessories

Protection of persons and property	40
<hr/>	
HVX circuit breaker	42
<hr/>	
CVX contactor	44
<hr/>	
Voltage transformers for PIX	46
<hr/>	
Current transformers for PIX	47
<hr/>	
Protection, monitoring and control	48
Easergy P3, Easergy P5 and MiCOM protection relays	48
Arc fault protection	50
Thermal monitoring Easergy TH110	52
Environmental monitoring Easergy CL110	53

Protection of persons and property

PM105207



The devices used to equip the PIX range of functional units have outstanding features:

- Long service life
- Maintenance-free live parts
- High electrical endurance
- Operating safety
- Insensitivity to the environment

The withdrawable parts

- The circuit breaker, the contactor, the disconnecter truck or the earthing truck
- The mechanism for racking in-out
- Interlocks to fix the withdrawable parts onto the fixed part

The live parts are housed in an insulating enclosure in the sealed pressure system in compliance with IEC 62271-100.

HVX Circuit breaker

The vacuum circuit breaker is the main device for switching the rated current and protecting against overcurrent and short circuit current.

Installed in the PIX cubicle it protects all components situated downstream during a short-circuit.

CVX contactor

The CVX vacuum contactor is used for multiple opening and closing operations at rated current. In combination with a fuse it protects all downstream installations. It fits into a PIX cubicle with a width of 650 mm and it uses similar operation features and interlocks to the HVX circuit breaker.

Earthing switch

The earthing switch earths the main current paths with a fast closing mechanism in accordance with IEC 62271-102.

Disconnecter truck

The disconnecter truck enables the upper and lower part of the cubicle to be short-circuited. It is installed instead of a circuit breaker and has the same interlock possibilities.

Metering truck

The metering truck measures the busbar voltage. It is installed instead of a circuit breaker and it has the same interlock possibilities.

Earthing truck

The earthing truck is a safety feature used during maintenance. It allows the injection of voltage for testing the cables or it allows earthing of the busbars. It is installed instead of a circuit breaker and has the same interlock capabilities.

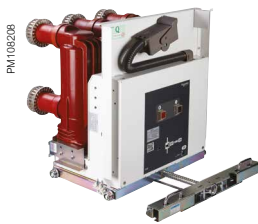

PM108208
HVX
Circuit breaker



PM108218
CVX
Contactor



PM108219

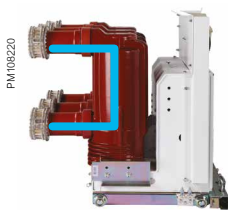

PM108220
UTX
Disconnecter truck

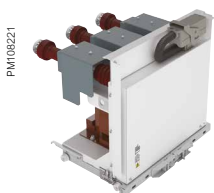

PM108221

MTX
Metering truck

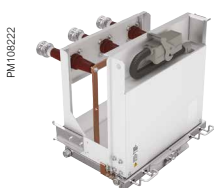

PM108222

Earthing
truck

HVX circuit breaker

General characteristics



HVX is a globally used, state of the art vacuum circuit breaker. Its design is the result of more than 40 years of Schneider Electric experience in switching devices. Its wide geographical deployment makes it a key component of PIX equipment. It has been designed to suit specific applications such as: heavy industry, oil&gas, metal&mines, and power generation. The materials used to manufacture this circuit breaker have been selected and designed to operate 10 000 cycles.

Interface operation

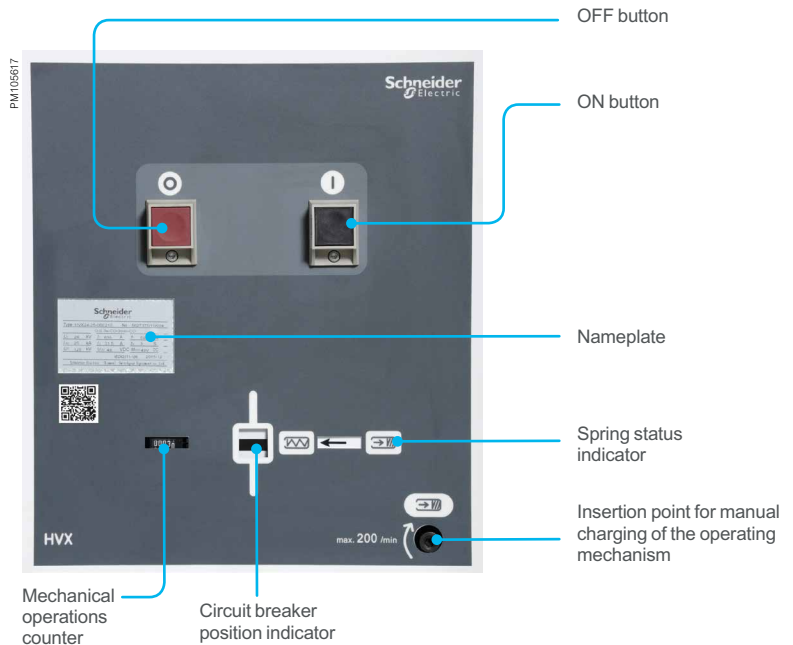

Racking device

The racking device moves the circuit breaker from the disconnected position to the service position and vice versa.

A motorized version of the truck provides remote rack in and rack out the circuit breaker.

The HVX racking device has a robust interlocking system with the switchgear door, the LV plug, the circuit-breaker and the earthing switch.

The materials used to manufacture the HVX racking trolley sub-assemblies have been selected and designed to operate 1 000 cycles under the conditions defined by the IEC standard.

Mechanism

The operating mechanism gives the device an opening and closing speed that is independent of the operator whether the order is electrical or manual. It carries out reclosing cycles and it is automatically recharged by a geared motor after each closing.

Vacuum interrupter

This component is the heart of the circuit breaker. The Schneider Electric owned design breaks the rated short-circuit current and this is achieved by:

- Choosing materials that are specifically selected for this application (metals and ceramics)
- Choosing an appropriate assembly process (vacuum, high temperature brazing)
- The use of a "getter" material to absorb the residual gas inside the enclosure

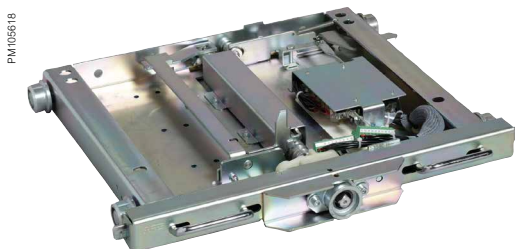

Racking trolley

HVX circuit breaker

General characteristics



Main electrical characteristics according to IEC 62271-100

Common characteristics				
Rated voltage	Ur	kV	12	17
Rated power frequency withstand voltage	Ud	kV	28	38
Rated lightning impulse withstand voltage	Up	kV	75	95
Rated frequency	f	Hz	50/60	50/60
Rated short circuit breaking current	Isc	kA	50	50
Rated peak short circuit current	Ip	kA	125	125
Rated duration of short circuit	tk	s	3	3
Operating sequence	O-0.3s-CO-3 min-CO			
	O-180s-CO-3 min-CO			
	O-0.3s-CO-15s-CO			
Opening time		ms	40-70	40-70
Arcing time		ms	≤ 15	≤ 1.5
Closing time		ms	30-60	30-60
Service temperature		°C	-25 ^{*1)} to +40	-25 ^{*1)} to +40
Mechanical endurance			M2	M2
Electrical endurance			E2	E2 ^{*1)}
Line charging breaking current	A		10	10
			C2	C2
Cable charging breaking current	A		25	31.5
			C2	C2
Single capacitor bank and back-to-back capacitor bank breaking capacity			^{*1)}	^{*1)}
Number of operation cycles			10 000	10 000
Higher number of operation cycles upon maintenance plan			30 000 ^{*1)}	30.000 ^{*1)}
Number of racking operations of circuit breaker trolley			1 000	1 000

*1) Please contact Schneider Electric

CVX contactor

PM100219



Basic characteristics

The CVX fused vacuum contactor has been specifically developed for switching motors, transformers, or capacitive loads.

- 3-phase or single-phase
- Magnetic holding or mechanical latch
- Electronic auxiliary supply to allow a wide range of control voltages
- High endurance
- Excellent capacitive switching performance

The CVX vacuum contactors with embedded pole fits into the PIX 650 mm panel.

Application

The CVX vacuum contactors are used when multiple opening and closing operations are needed. It is widely used in metallurgy, mining, petrochemical industries, in drilling platforms and in other industries with a need for frequent switching of motors and capacitors or transformer neutral earthing.

Operation mechanism

Opening and closing of the contactor is controlled via a closing coil, the closing position is held by the closing coil and supported by an electronic card or by a mechanical latch.

Vacuum interrupter

The CVX vacuum contactor uses the small seized VS series vacuum interrupters produced by Schneider Electric.

PM105613



VS series interrupter

PM108224

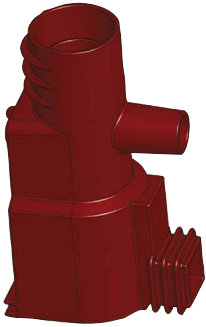

Embedded pole

The vacuum interrupter is embedded in epoxy for small dimensions and to protect all parts of the pole against harsh environments.

PM108225

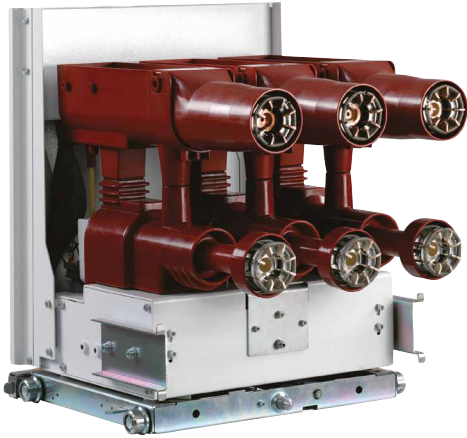

Racking device

The racking device moves the disconnecter from the disconnected position to the service position and vice versa.

The racking device follows the same design principles as the circuit breaker.

The CVX racking device has a robust interlocking system with the contactor position and contactor switching condition and the switchgear door, the low voltage plug and the earthing switch.

A motorized version is available on request.

Main characteristics

Characteristics for CVX contactors			
Rated voltage	Ur	kV	12
Rated frequency	f	Hz	50/60
Rated short circuit breaking capacity with fuses	Isc	kA	50
Rated short term withstand current with fuses	Isc	kA	150
Rated short circuit breaking capacity contactor without fuses	Isc	A	3200
Rated short term withstand current contactor without fuses	Isc	A	4000
Rated current contactor	Ir	A	160
Electrical life, operations			250 000
Mechanical life, operations	electric self-held		1 000 000
	mechanical self-held		300 000
Closing time		ms	100-250
Opening time	electric self-held	ms	80-200
	mechanical self-held	ms	30-100
Operation voltage	closing	V	110 AC/DC, 220 AC/DC
	electrical held	V	110 AC/DC, 220 AC/DC
	opening	V	110 AC/DC, 220 AC/DC

Voltage Transformers for PIX

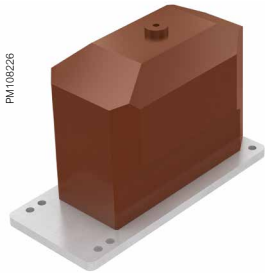

PM10826
*Voltage transformer-
single pole*

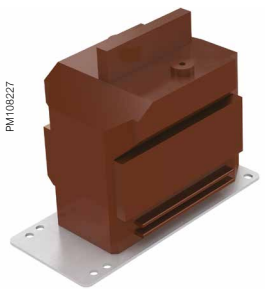

PM10827
*Voltage transformer-
double pole*

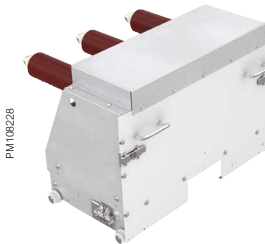

PM10828
*Voltage transformer
on withdrawable truck
with fuses*

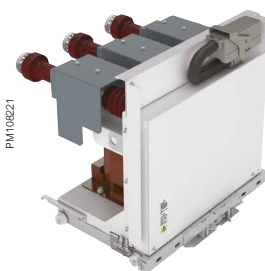

PM10821
*Voltage metering truck
for busbar voltage*

Conventional voltage transformers provide a low voltage output (100 V or 110 V) for:

- Protection devices
- Measuring, metering and monitoring devices

They are based on the inductive principle according to IEC 61869-3.

They include the following models:

- Single pole version for measuring between phase and neutral
- Double pole version for metering between two phases

They are installed at the bottom of the panel for voltage metering on the cable side.

There are models with or without protection fuses and the following arrangements:

- Fixed type version with or without fuses
- Withdrawable version and equipped with fuses.

The withdrawable truck can remove the complete functional unit, thereby easily replacing the fuses.

To meter the busbar voltage there is a specific voltage metering truck equipped with a voltage transformer with fuses.



PM10821
*Voltage transformer on
withdrawable
truck with fuses*

Current transformers for PIX

PM10B229

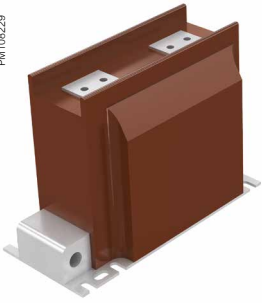

CT-01/Block type

PM10B230

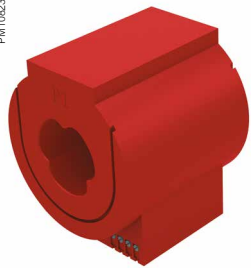

CT-02/Ring type

Conventional current transformers provide a power signal for:

- Protection devices
- Measuring, metering and monitoring devices

They measure the value of the primary current from 10 A to 4000 A.

They are based on the inductive principle according to IEC 61869-2.

They are installed at the bottom of the panel for current metering on the cable side.

They are offered with the following models:

- Block type, epoxy resin insulated
- Ring type or toroidal type

Ring type current transformers can be used to measure both the current per phase or to detect an earth fault by comparing three phases. They can be epoxy resin insulated or foil insulated.

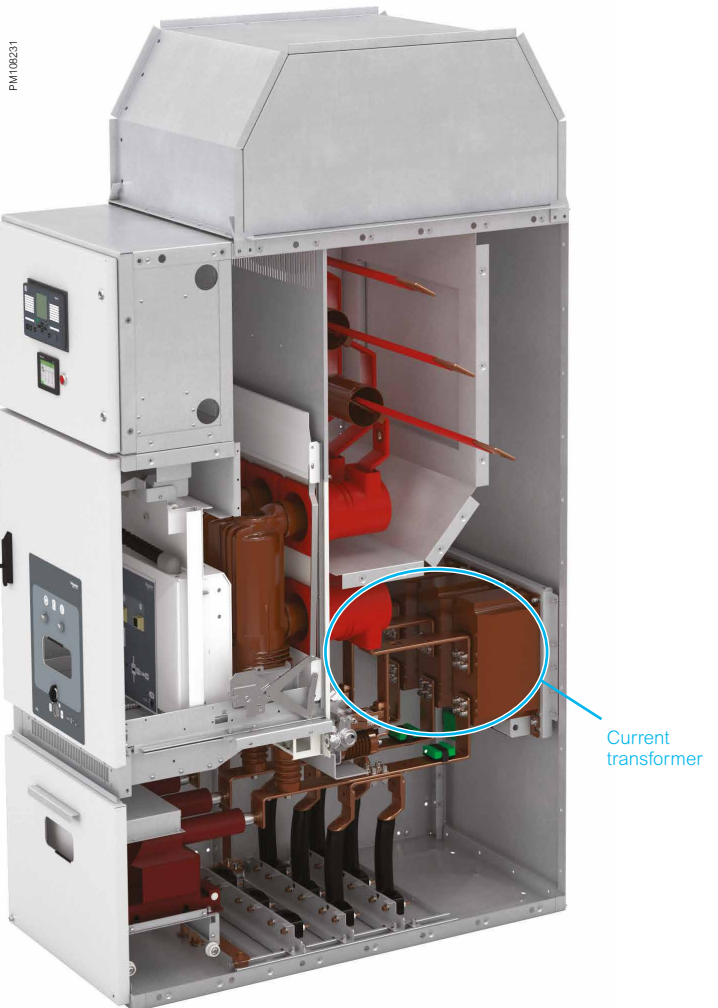

PM10B231

Current transformer

Protection, monitoring & control

Easergy P5, Easergy P3 and MiCOM protection relays



Easergy P5: All-in-one best-in-class features

The Easergy P5 presents a major step forward for protection relays, bringing a number of best-in-class features together in one device.

Built-in arc flash protection

By detecting if an arc flash exists, the device takes action within milliseconds to disconnect and mitigate risks. This means the arc does not have a chance to grow and cause unexpected outages or dangers.

Advanced cybersecurity

IEC62443 compliant, the P5 has been designed with an optional cybersecurity package. This means reduced exposure to cyber threats and improved operational security. By default, the Easergy P5 includes important features such as password management, port hardening, and secure communication.

Intuitive withdrawable design

With a handle built in as part of the design, the P5 can be quickly disconnected or exchanged to speed up maintenance. Wiring, data, communication, and settings stay safely on the panel and will be there when the relay is reconnected.

Improved recovery time

When maintenance or testing is required, Easergy P5 helps dramatically decrease your outage recovery time. The backup memory can automatically restore settings, you can continue your operations in as little as 10 minutes. *

* Result of mean time to repair (MTTR) calculation conducted by Schneider Electric

Greater connectivity

The protection relay features seven communication protocols. This includes compliance with IEC 61850 ed.1 and ed.2, Modbus (serial/TCP), IEC 60870-5-103, IEC 60870-5-101, Ethernet/IP, and DNP3 (serial/TCP). Additionally, thanks to the P5's modular design, communication ports can be added at any time to enable you to upgrade your device in line with future network upgrades.

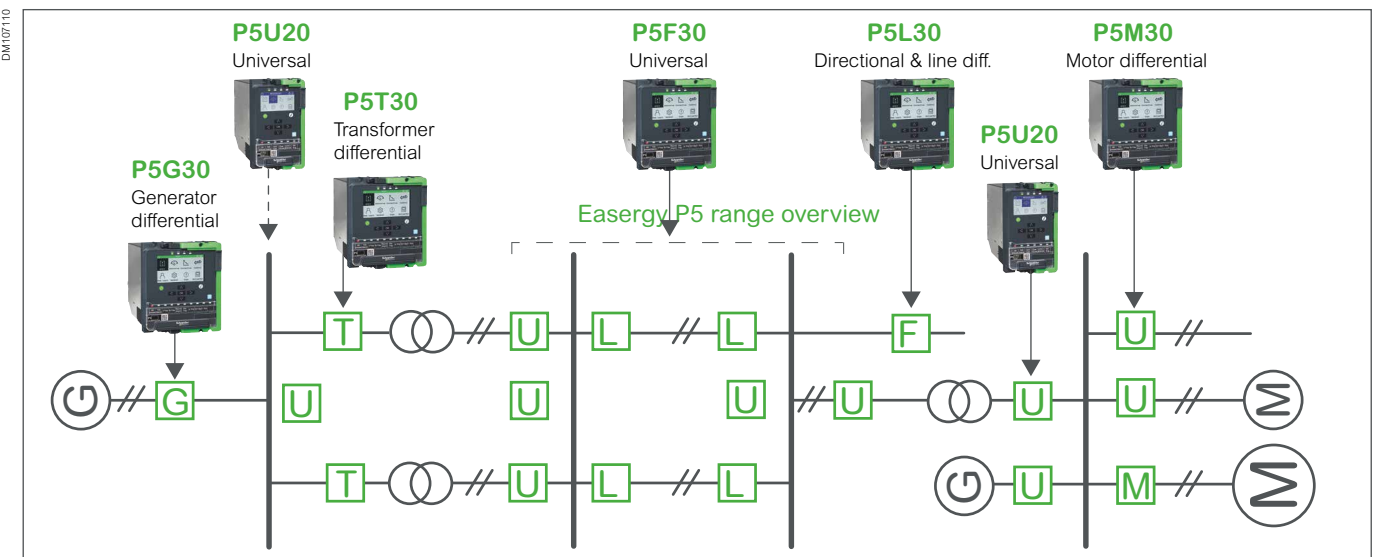

Protection, monitoring & control

Easergy P5, Easergy P3 and MiCOM protection relays

Easy to use

User-friendliness is a key benefit of Easergy P3, made to save time at every step of the project's life-cycle.

A great deal of effort has gone into designing the operational aspects of the new products. Setting and download/upload are much faster thanks to the unique eSetup Easergy Pro setting software which dramatically improves usability.

The informative human machine interface shows the information the user needs, with the support of customized key texts.



Enhanced usability

The Easergy P3 protection relay concept has been extended with a number of features that make installation and testing of the relays even more efficient and user-friendly, like the virtual injection testing accessible with eSetup Easergy Pro setting software.

P3 Standard Universal applications

P3 Advanced Advanced applications with arc flash fault detection



P3U 10/20/30: Universal protection

- Feeder and Transformer
- Motor
- Voltage
- Frequency
- Capacitor

- **P3F30:** Feeder and Transformer
- **P3M30:** Motor
- **P3G30:** Generator
- **P3L30:** Line differential and Distance
- **P3T32:** Transformer differential type
- **P3M32:** Motor differential
- **P3G32:** Generator differential type

Easergy P3: Solid protection meets unparalleled efficiency

The Easergy P3 protection relay family is based on proven technology designs developed in close cooperation with our customers. Easergy products have been designed around user-friendliness, a feature which is highlighted in our customer feedback day after day.

The Easergy P3 feeder manager has been developed to cover basic protection needs for OEMs, utilities and industrial applications. Thanks to its cost-effective and flexible design, the Easergy P3 provides an alternative for various protection applications.

Easergy P3 combines additional protection functions such as directional earth fault for feeder and motor protection.

Unparalleled efficiency

- Simple selection and ordering with EcoReal MV
- Faster delivery with instant availability for standard configurations
- Simplified configuration with the new eSetup Easergy Pro setting tool

Better Connectivity

- Simpler operation and maintenance with the Easergy P3 SmartApp
- All communication protocols included natively, including IEC 61850
- Option to use two active communication protocols in the same time
- Increased number of inputs and outputs for more options

Enhanced safety

- Embedded arc protection
- Built-in virtual injection testing
- Compliant to international standards (IEC 60255-1)

Easergy MiCOM protection relays

Easergy MiCOM protection provides the user with a choice of cost-optimized solutions for specific protection requirements within the distribution network.

The Easergy MiCOM relay series offers comprehensive protective function solutions for all power supply systems, as well as for the various functional and hardware project stages.

With their modular design, the Easergy MiCOM device platforms provide the user with multifunctional equipment that can act as:

- Grid protection equipment, and
- Combined protection and control systems
- Easergy MiCOM devices integrate most standard communication protocols used in station control systems and SCADA systems
- Due to the continuous further development of these products, compatibility with technical progress in the field of switchgear and controlgear communication is ensured

Easergy MiCOM offers varying levels of functionality and hardware

- **Series 30** is designed to meet the rigorous requirements of MV & HV applications with particular focus on feeder and transformer protection and control.
- **Series 40** fulfills the protection requirements for a wide market of utility and industrial systems and offers a complete range of protection functions.



Arc fault detectors selection guide

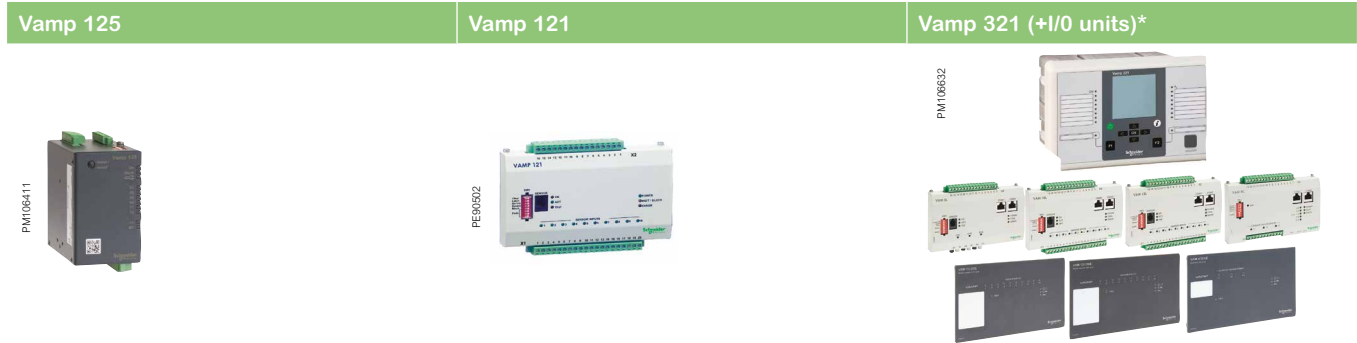

Functions

The arc protection unit detects an arc flash in an installation and quickly trips the feeding breaker.

System features

- | | | |
|--|---|--|
| <ul style="list-style-type: none"> • Typical operation on light only principle <ul style="list-style-type: none"> - Input for current criteria for I> and L> operation - Integrated 19 - 256 V AC/DC aux. supply • Optimized for wind power and other small applications • Up to 4 arc sensors • Selective trip for 2 zones • Operation time 1 ms with high speed output and 8 ms with a trip relay • Non-volatile trip status • Self-supervision • Straightforward installation • Cost-effective solution | <ul style="list-style-type: none"> • Operation on light only • Up to 10 arc or smoke sensors • Single trip contact • Straightforward installation • Operation time 9 ms (including the output relay) • Cost-effective solution • Self-supervision • Binary input for blocking or resetting the unit (programmable) • Option for double arc channel activation trip criteria • BIO light transfer option to other Vamp devices | <ul style="list-style-type: none"> • Flexible and modular system can be adapted to different targets requiring arc protection • Central unit and modular units engineer a scheme to your requirements • Continuous system self-supervision • 3-phase current, zero-sequence voltage and current • Event logs, disturbance recording and real-time clock • Operation on simultaneous current and light or on light only • Direct connection of arc sensors in the central unit without using I/O units • 7 ms operation time with trip contact and 2 ms with high speed output (HSO) • Programmable operation zones • Communication protocol support for SCADA and automation interfacing • Supports a maximum of 6 Digital Inputs and 8 Digital Outputs for object (CB) status and control (order option dependent) |
|--|---|--|

Sensors

Point sensor - surface

- Arc detection from two compartments simultaneously
- Self-monitored
- Cable length adjustable from 6 m to 20 m down

Point sensor - pipe

- Self-monitored
- Cable length adjustable from 6 m to 20 m down

Loop sensor

- Monitors various compartments
- Small bending radius for easy installation

Benefits

- Reduces production losses
- Extended switchgear life cycle
- Reduced insurance costs
- Low investment costs and fast installation
- Enhancing people safety

IEC standards	IEC standards	IEC standards
---------------	---------------	---------------

* I/O units: 4 references available (VAM 3L, VAM 10L/LD, VAM 12L/LD, VAM 4C/CD). The choice is to be made according to the needs concerning the type and number of sensors. Please contact us.

The arc protection unit detects an arc flash in an installation and trips the feeding breaker

An arc flash protection system minimizes material damage caused by arc faults.

Arc flash protection minimizes material damage to the installation in most hazardous power system fault situations.

Minimized damage also means limited need for repair work and enables rapid restoration of the power supply.

Vamp arc flash range



Advantages

People protection

The shorter the operating time of the arc flash protection unit, the smaller the damage will be caused by the arc fault and the shorter the possible power outage.

Extended switchgear life cycle

Arc protection unit increases the life-cycle expectancy of switchgear installations, so that decisions to invest in new switchgear installations can be postponed and money can be saved by re-vamping existing switchgear systems.

Reduced insurance costs

Cost savings can be made with fast and suitable protection systems for a power installation.

Low investment costs and fast installation

A comprehensive arc protection system is characterized by low investment costs and fast installation and commissioning times. One successful operation of the arc flash protection units provides an immediate investment payoff.

Reliable Operation

Operation is based on the appearance of light or alternatively on the appearance of light and current from an external device. Immune to nuisance trippings due to dual tripping criteria; light & current.

Key benefits

- Battery free
- Wireless communication
- High performance
- In contact measuring point
- Easy installation
- Compact footprint
- Remote monitoring and alarming

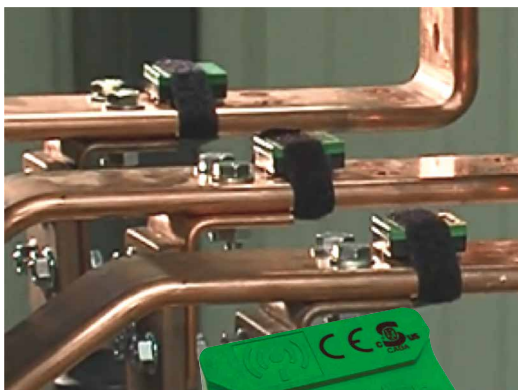

Easergy TH110

Continuous Thermal Monitoring

The power connections in the Medium Voltage products are one of the most critical points of the substations especially for those made on site like:

- MV Cable connections

Loose and faulty connections cause an increase of resistance in localized points that will lead to thermal runaway until the complete failure of the connections.

Preventive maintenance can be complicated in harsh operating conditions also due to limited accessibility and visibility of the contacts.

Continuous thermal monitoring is the most appropriate way to detect a compromised connection early.

Easergy TH110 Thermal Sensor

Easergy TH110 is part of the **new generation of wireless smart sensors** enabling the continuous thermal monitoring of the connections made on field allowing to:

- Prevent unscheduled downtime
- Increase operator and equipment safety
- Optimize and predict maintenance

Thanks to its very **compact footprint** and its **wireless communication**, Easergy TH110 allows an easy and widespread installation in every possible critical points without impacting on the performance of MV switchgear.

By using the **Zigbee Green Power** communication protocol, Easergy TH110 enables a reliable and robust communication that can be used to create interoperable solutions which are evolving in the age of the Industrial **Internet of Things** (IIoT).

Easergy TH110 is **self-powered** by the network current and it can ensure **high performance** providing accurate thermal monitoring being in **direct contact** with the measured point.

Substation Monitoring Device

Easergy TH110 is **connected** to the Substation Monitoring Device (SMD) that harvests the data for local signaling, data analyses and nearby control.

Specific **monitoring algorithms** detect drifts from the threshold based on the specific installation characteristics also in regards of the variable loads or abnormal behaviors coming from phase comparison.

The **remote monitoring and alarming** includes remote connection for SCADA or Services, access to Cloud-based Apps and digital services and alarming through SMS or the Facility Hero mobile App.

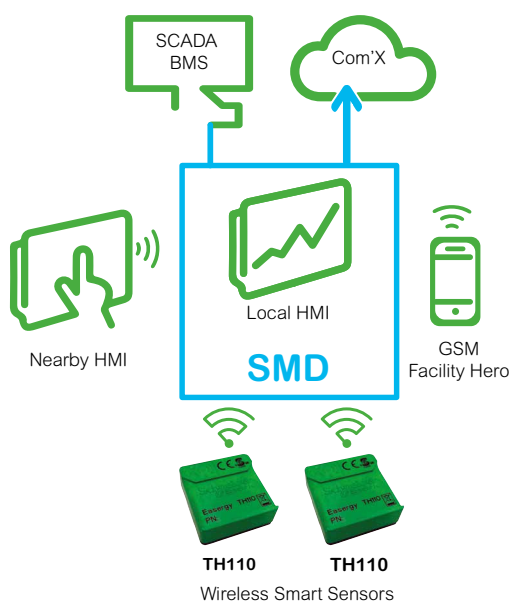

Characteristics

Power supply	Self-powered. Energy harvested from power circuit.
Minimum activation current	5 A
Accuracy	+/- 1°C
Range	-25 °C/+115°C
Wireless communication	ZigBee Green Power 2,4 GHz
Dimension - Weight	31 x 31 x 13 mm - 15 g

Protection, monitoring & control

Environmental monitoring

Easergy CL110

Key benefits

- Long battery life
- Wireless communication
- High performance
- In contact measuring point for temp.
- Easy installation with magnets
- Compact footprint
- Remote monitoring and alarming

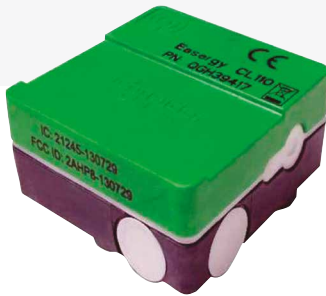

Easergy CL110

Characteristics

Temperature Accuracy	+/- 1°C in a range from -25°C to 90°C
Relative Humidity Accuracy	2% in a range from 10% to 98%
Wireless Communication	ZigBee Green Power 2,4GHz
Protection degree	IP54
Dimension - weight	40x40x21 mm – 34g
Power supply	3V battery

Continuous Environmental Monitoring

Harsh environments due to pollution, condensation and strong temperature drifts is one of the most critical failure causes due to accelerated aging.

In **MV Switchgear** a harsh environment generates dirt that, on the surface of the shielded insulators, can lead to partial surface discharges up to a complete flashover.

In **LV compartments** a harsh environment can generate rust on metallic parts and electronic contacts.

Continuous environmental monitoring is the most appropriate way to detect installation issues early, thereby optimizing maintenance with predictive information.

Easergy CL110 Environmental Sensor

Easergy CL110 is part of the **new generation of wireless smart sensors** enabling the continuous environmental condition monitoring to perform, over a de-energized surface, the measurement of the:

- Temperature of the surface in contact
- Relative humidity

By using proper algorithms, the above data can be computed to calculate the dew point and condensation occurrence.

Thanks to its **compact footprint** and its **wireless communication** the Easergy CL110 allows an easy and widespread installation also providing IP54 degree of protection in indoor applications.

Easergy CL110 is **battery powered with a life expectancy of >15 years** and it allows a simple fixing on magnetic metal surfaces thanks to its **powerful magnets**.

By using the **Zigbee Green Power** communication protocol, Easergy CL110 enables a robust communication that can be used to create interoperable solutions evolving in the age of the **Industrial Internet of Things (IIoT)**.

Easergy CL110 provides accurate temperature monitoring of the metal surface because it is in **direct contact** with it.

Substation Monitoring Device

Easergy CL110 **is connected** to the Substation Monitoring Device (SMD) that harvest the data for local signaling, data analyses and nearby display.

Specific **monitoring algorithms** detect drifts from the threshold based on the specific installation characteristics.

The remote **monitoring and alarming** includes remote connection for SCADA or Services, access to Cloud-based Apps and digital services and alarming through SMS or the Facility Hero mobile App.

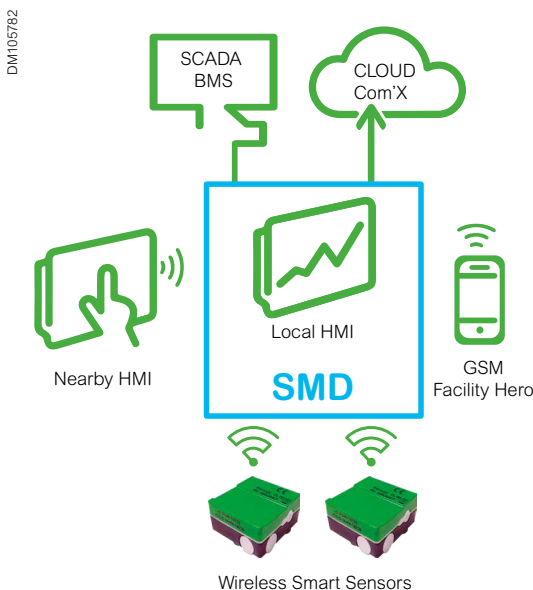

Installation and connection

Installation and connection

Accessories and extraction withdrawable parts	56
<hr/>	
Installation example	57
PIX 17.5 kV line-up switchboard	57
<hr/>	
Connections	58
<hr/>	
Cubicle equipment	60
PIX 17.5 kV	60

Accessories and extraction withdrawable parts

PM108236

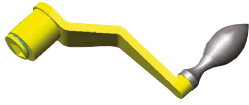

Circuit breaker truck racking-in crank

PM108237



Earthing switch operating handle

PM108238



Transport truck

The accompanying documents generally include the following:

- Certificate of conformity and delivery inspection report
- Operating instructions
- Secondary connection diagram and switchgear lineup drawing
- Packing list

Accessories

- Circuit breaker truck racking-in crank
- Earthing switch operating handle

Spare parts

The transport truck must be ordered separately as well as other spare parts in accordance with the order contract.

Installation example

PIX 17.5 kV line-up switchboard

Line-up switchboard

(2 incomer cubicles and 1 bus section)

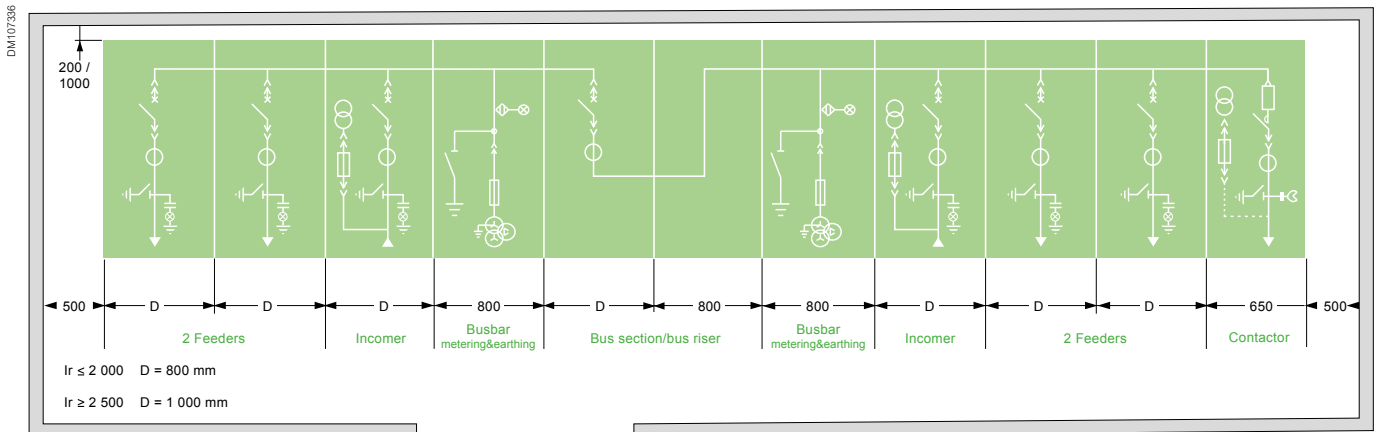

Civil engineering

1. Minimum dimensions to be complied with when installing the PIX switchboard
2. Minimum dimensions to be defined according to the cable bending radius
3. Operating distance
4. Distance needed to extract a functional unit from the switchboard without moving the other units

- A. Anchor point
B. Adjustment point

Different solutions for gas exhaust are available:
tunnel, tunnel with absorber

Note: for further information, refer to the user manual.

Dimensions of the electrical room:

Installation	IAC	D (mm)	H (mm)	R (mm)
Middle of the room	A FLR	1 590	3 300	1 000
Close to the wall	A FL	1 590	3 300	200

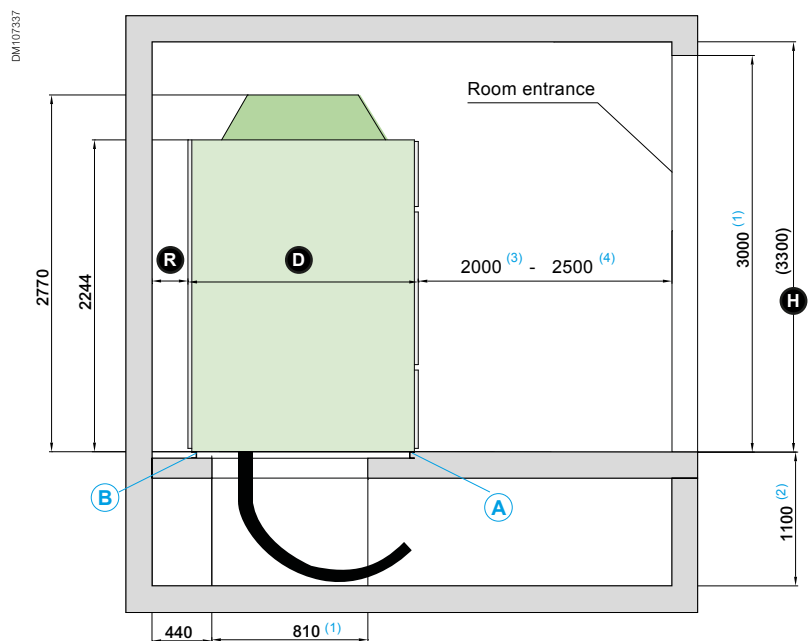

Cold connected terminals

For optimum durability, Schneider Electric's experience has led it to favour this technology wherever possible.

The maximum acceptable cable cross-section for standard assemblies are:

- 630 mm² for incomer or feeder cubicles with single-pole cables
- 400 mm² for incomer or feeder cubicles with three-pole cables
- 95 mm² for transformer protection cubicles with fuses

Access to the compartment is only possible when the earthing switch is closed.

The cable torque is to be done using a dynamo wrench set to 50 mN.

The torque to fix the cables has to be considered in accordance with the SE user manual.

Switchgear resistance to aging in a substation depends on 3 key factors

- **Connections must be performed correctly**
New cold connecting technologies offer easy installation and favor durability over time. Their design means they can be used in polluted environments with harsh atmospheres.
- **The impact of relative humidity**
The installation of a heating element is essential in climates with high relative humidities and significant temperature variations.
- **Ventilation control**
The dimensions of air vents must be appropriate for the dissipated energy in the substation.

Dry, single-pole cable

Short end piece, cold connectable

Performance	up to 17.5 kV, up to 4 000 A
Cross section mm ²	50 to 630 mm ²
Supplier	All suppliers of cold connectable terminals: Silec, 3M, Pirelli, Raychem, etc.
Number of cables	1 to 8 per phase
Comments	For a greater cross-section and number of cables, please contact us

Dry, three-pole cable

Short end piece, cold connectable

Performance	up to 17.5 kV, up to 4 000 A
Cross section mm ²	50 to 240 mm ²
Supplier	All suppliers of cold connectable terminals: Silec, 3M, Pirelli, Raychem, etc.
Number of cables	1 to 4 per phase
Comments	For a greater cross-section and number of cables, please contact us

Cable connection

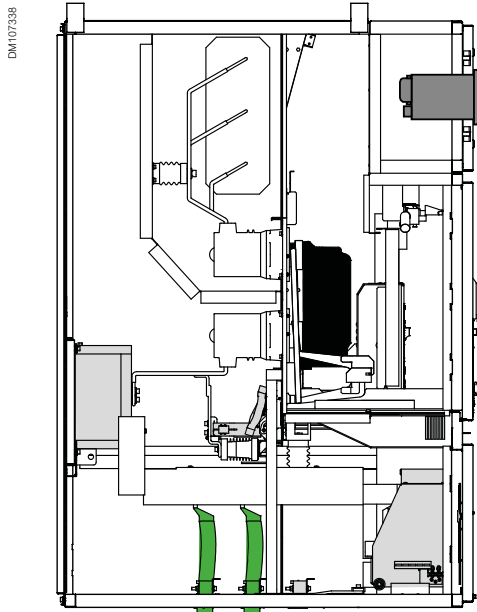

PIX cable bottom entry

Type of cubicle	Panel width (mm)	Rated current (A)	Max. no of cables & size (mm ²)	Height of cable connection (mm)
Feeder	800	1 250	6*630	452
	1 000	2 000	8*630 ⁽¹⁾	437
		≥ 2 500	8*630 ⁽¹⁾	421
Feeder-contactor	650	160	2*240	452

(1) Bigger dimensions on request

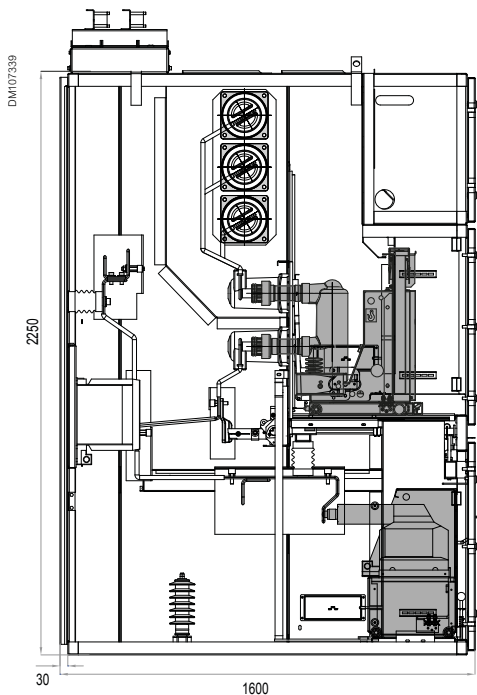

Type of cubicle	Panel width (mm)	Rated current (A)	Max. no of cables & size (mm ²)
Feeder	800	1 250	6*630
	1 000	2 000	8*630 ⁽¹⁾
		≥ 2 500	8*630 ⁽¹⁾
Feeder-contactor	650	160	2*240

(1) Top cable connection on request

Equipment			Type of cubicle				
			F	F-C (*)	BS	BR	BME
Circuit breaker			●		●		
Contactor				●			
Disconnecter truck			●				
Metering truck for busbar voltage							●
Racking position indication contacts for the withdrawable part		4NO+4NC	●	●	●		●
Padlocking of isolating shutters for withdrawable part			●	●	●		
Voltage presence indicator			●	●	●	●	●
Locking of racking mechanism of the withdrawable part (padlock)			●	●	●		
Locking of racking mechanism of the withdrawable part (keylock)			○	○	○		
Locking of the electrical racking of the withdrawable part			○	○	○		
Earthing switch							
Earthing switch			●	●	●	●	●
Earthing switch position indication contacts		4NO+4NC	●	●	●	●	●
Earthing switch pad lock			●	●	●	●	●
Earthing switch key lock (*)			○	○	○	○	○
Instrument transformers							
Voltage transformers	Cable side, fixed type	Phase-earth	●	●			
		Phase-phase	●	●			
Voltage transformers	Cable side, withdrawable type (*)	Phase-earth	○	○			
		Phase-phase	○	○			
Voltage transformers	Busbar side, withdrawable type, metering truck	Phase-earth				○	●
		Phase-phase				○	●
Current transformers	one set	3 CTs	●	●	○		
	two sets	6 CTs	○				
	ring type		○				
Connections							
Connection with cable from bottom			●	●			
Connection with cable from top (*)			○	○			
Connection with bars from top (*)			○	○			
Cubicle							
Protection	IP4X		●	●	●	●	●
	IPX1 (*)		○	○	○	○	○
	IPX2 (*)		○	○	○	○	○
Busbars							
1250 A/2500 A /3150 A/4000 A		Insulated	●	●	●	●	●
Others							
LV control cabinet lightning			○	○	○	○	○
Anti-condensation heating element			○	○	○	○	○
Earthing truck for maintenance			○	○	○		
Transportation trolley/1 000 mm, 800 mm, 650 mm			●	●	●	●	●

● Basic equipment

○ Option

(*) On request

Notes



TOOLS

schneider-electric.com

This international website gives you access to all the Schneider Electric solutions and product information via:

- Comprehensive descriptions
- Range datasheets
- A download area
- Product selectors

You can also access information dedicated to your business and contact your Schneider Electric country support.

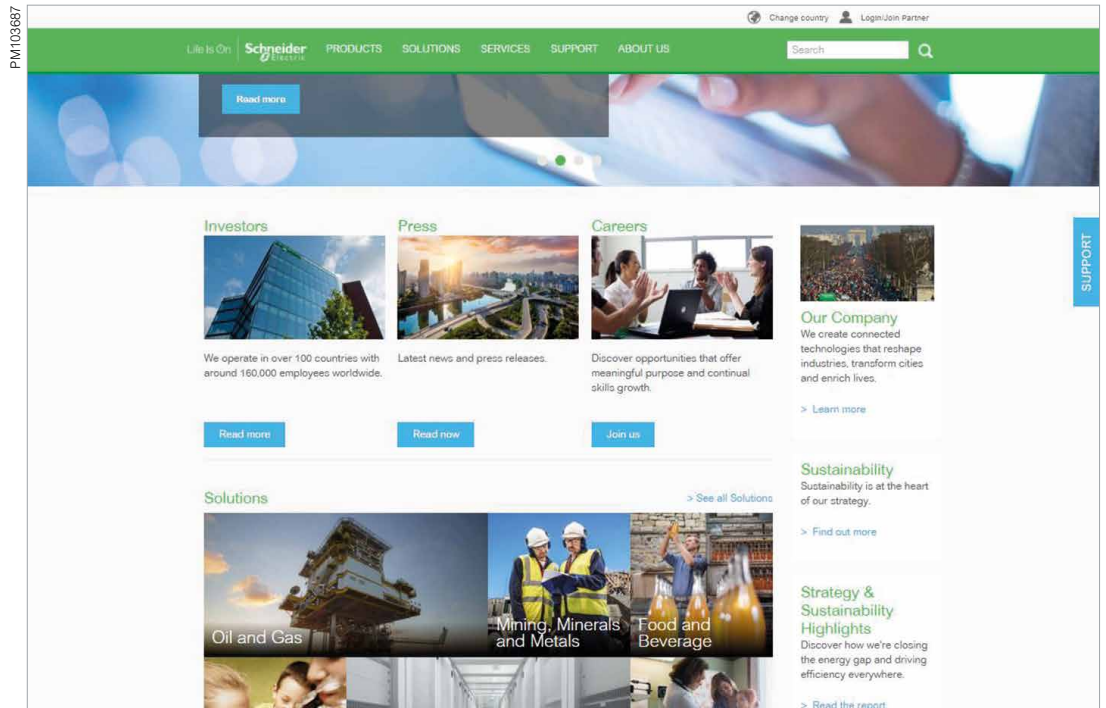



TOOLS

Web selector

This site gives you access to the Schneider Electric products in just two clicks via a comprehensive range of datasheets, with direct links to:

- Complete libraries: technical documents, catalogs, FAQs, brochures
- Selection guides from the catalog
- Product discovery sites and their animations

You will also find illustrated overviews, news to which you can subscribe, and a list of country contacts

Training

Training allows you to acquire the expertise (installation design, work with power on, etc.) to increase efficiency and improve customer service.

The training catalog includes beginner's courses in electrical distribution, knowledge of MV and LV switchgear, operation and maintenance of installations, and design of LV installations, to give a few examples.

Schneider Electric Industries SAS

35 rue Joseph Monier
92500 Rueil-Malmaison, France
Tel : +33 (0)1 41 29 70 00

www.schneider-electric.com

21, August, 2019

NRJCAT18804EN

©2019 Schneider Electric SE. All Rights Reserved.

All Schneider Electric trademarks and service marks are the property of Schneider Electric SE, its subsidiaries and affiliated companies.