

PowerLogic™

AccuSine PCS+ Active Harmonic Filter AccuSine PFV+ Electronic VAR Control

600-690 Volt UL Type 2, UL Type 12, IP31, and IP54

Installation Manual

PowerLogic offers power quality, uptime and efficiency.

NHA71461-02

11/2024

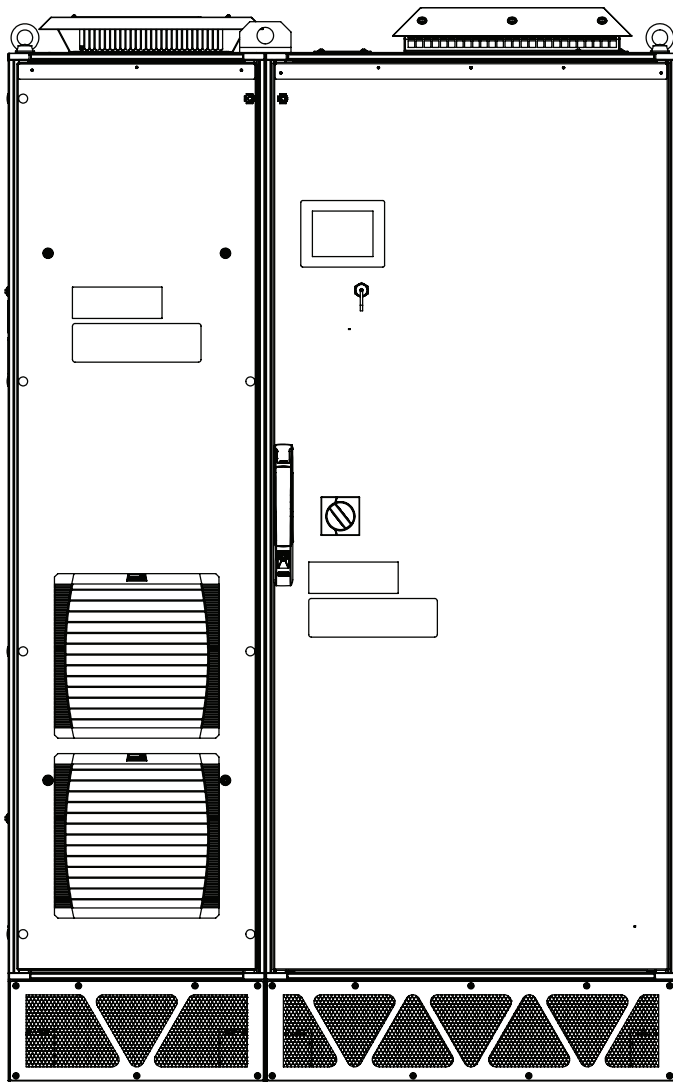

Legal Information

The information provided in this document contains general descriptions, technical characteristics and/or recommendations related to products/solutions.

This document is not intended as a substitute for a detailed study or operational and site-specific development or schematic plan. It is not to be used for determining suitability or reliability of the products/solutions for specific user applications. It is the duty of any such user to perform or have any professional expert of its choice (integrator, specifier or the like) perform the appropriate and comprehensive risk analysis, evaluation and testing of the products/solutions with respect to the relevant specific application or use thereof.

The Schneider Electric brand and any trademarks of Schneider Electric SE and its subsidiaries referred to in this document are the property of Schneider Electric SE or its subsidiaries. All other brands may be trademarks of their respective owner.

This document and its content are protected under applicable copyright laws and provided for informative use only. No part of this document may be reproduced or transmitted in any form or by any means (electronic, mechanical, photocopying, recording, or otherwise), for any purpose, without the prior written permission of Schneider Electric.

Schneider Electric does not grant any right or license for commercial use of the document or its content, except for a non-exclusive and personal license to consult it on an "as is" basis.

Schneider Electric reserves the right to make changes or updates with respect to or in the content of this document or the format thereof, at any time without notice.

To the extent permitted by applicable law, no responsibility or liability is assumed by Schneider Electric and its subsidiaries for any errors or omissions in the informational content of this document, as well as any non-intended use or misuse of the content thereof.

As part of a group of responsible, inclusive companies, we are updating our communications that contain non-inclusive terminology. Until we complete this process, however, our content may still contain standardized industry terms that may be deemed inappropriate by our customers.

Safety information

Important information



Read these instructions carefully and look at the equipment to become familiar with the device before trying to install, operate, service or maintain it. The following special messages may appear throughout this bulletin or on the equipment to warn of potential hazards or to call attention to information that clarifies or simplifies a procedure.

The addition of either symbol to a “Danger” or “Warning” safety label indicates that an electrical hazard exists which will result in personal injury if the instructions are not followed.

This is the safety alert symbol. It is used to alert you to potential personal injury hazards. Obey all safety messages that follow this symbol to avoid possible injury or death.

DANGER

DANGER indicates a hazardous situation which, if not avoided, **will result in death** or serious injury.

WARNING

WARNING indicates a hazardous situation which, if not avoided, **could result in death** or serious injury.

CAUTION

CAUTION indicates a hazardous situation which, if not avoided, **could result in minor or moderate injury**.

NOTICE

NOTICE is used to address practices not related to physical injury.

Please note

Electrical equipment should be installed, operated, serviced and maintained only by qualified personnel. No responsibility is assumed by Schneider Electric for any consequences arising out of the use of this material.

A qualified person is one who has skills and knowledge related to the construction, installation, and operation of electrical equipment and has received safety training to recognize and avoid the hazards involved.

Safety precautions

Installation, wiring, testing and service must be performed in accordance with all local and national electrical codes.

DANGER

HAZARD OF ELECTRIC SHOCK, EXPLOSION, OR ARC FLASH

- Apply appropriate personal protective equipment (PPE) and follow safe electrical work practices. See NFPA 70E in the USA, CSA Z462, or applicable local standards.
- This equipment must be installed and serviced only by qualified electrical personnel.
- Do not exceed the device's ratings for maximum limits.
- Ground equipment using the ground connecting point provided before turning on any power supplying this device.
- Turn off all power supplying this device and the equipment in which it is installed before working on the device or equipment.
- After removing power, wait for 15 minutes to allow the capacitors to discharge prior to opening the doors or removing covers.
- Always use a properly rated voltage sensing device to confirm power is off.
- Replace all devices, doors, and covers before turning on power to this equipment.
- Carefully inspect the interior for tools left behind before closing and sealing the door.

Failure to follow these instructions will result in death or serious injury.

Cybersecurity

Introduction

Cybersecurity is a branch of network administration that addresses attacks on or by PCs and through PC networks that can result in accidental or intentional disruptions. The objective of cybersecurity is to help provide increased levels of protection for information and physical assets from theft, corruption, misuse, or accidents while maintaining access for their intended users.

No single cybersecurity approach is adequate. Schneider Electric recommends a defense-in-depth approach. Conceived by the National Security Agency (NSA), this approach layers the network with security features, appliances, and processes. The basic components of this approach are:

- Risk assessment
- Security plan built on the results of the risk assessment
- Multi-phase training campaign
- Physical separation of the industrial networks from enterprise networks using a demilitarized zone (DMZ) and the use of firewalls and routing to establish other security zones
- System access control
- Device hardening
- Network monitoring and maintenance

This section defines elements that help you configure a system that is less susceptible to cyber attacks. For detailed information on the defense-in-depth approach, refer to the Recommended Cybersecurity Best Practices on the Schneider Electric website.

Schneider Electric's Approach on Cybersecurity

Schneider Electric adheres to industries best practice in the development and implementation of control systems. This includes a defense-in-depth approach to secure an industrial control system. This approach places the controllers behind one or more firewalls to restrict access to authorized personnel and protocols only.

WARNING

UNAUTHENTICATED ACCESS AND SUBSEQUENT UNAUTHORIZED OPERATION

- Evaluate whether your equipment or complete environment are connected to your critical infrastructure. If so, take appropriate steps in terms of prevention, based on defense-in-depth, before connecting the automation system to any network.
- Limit the number of devices connected to a network inside your company.
- Isolate your industrial network from other networks inside your company.
- Protect any network against unintended access by using firewalls, VPN, or other, proven security measures.
- Monitor activities within your systems.
- Prevent subject devices from direct access or direct link by unauthorized parties or unauthenticated actions.
- Prepare a recovery plan including backup of your system and process information.

Failure to follow these instructions can result in death, serious injury, or equipment damage.

Cyber Threats

Cyber threats are deliberate actions or accidents that can disrupt the normal operations of PCs and PC networks. These actions can be initiated from within the physical facility or from an external location. Security challenges for the control environment include:

- Diverse physical and logical boundaries.
- Multiple sites and large geographic spans.
- Adverse effects of security implementation on process availability.
- Increased exposure to worms and viruses migrating from business systems to control systems as business-control communications become more open.
- Increased exposure to malicious software from USB devices, vendor and service technician laptops, and the enterprise network.
- Direct impact of control systems on physical and mechanical systems.

Sources of Cyber Attacks

Implement a cybersecurity plan that accounts for various potential sources of cyberattacks and accidents, including:

Source	Description
Internal	<ul style="list-style-type: none"> – Inappropriate employee or contractor behaviour – Disgruntled employee or contractor
External opportunistic (non-directed)	<ul style="list-style-type: none"> – Script kiddies⁽¹⁾ – Recreational hackers – Virus writers
External deliberate (directed)	<ul style="list-style-type: none"> – Criminal groups – Activists – Terrorists – Agencies of foreign states
Accidental	
⁽¹⁾ Slang term for hackers who use malicious scripts written by others without necessarily possessing a comprehensive understanding of how the script works or its potential impact on a system	

A deliberate cyber attack on a control system may be launched to achieve a number of malicious results, including:

- Disrupt the production process by blocking or delaying the flow of information.
- Damage, disable, or shut down equipment to negatively impact production or the environment.
- Modify or disable safety systems to cause intentional harm.

How Attackers Gain Access

A cyber attacker bypasses the perimeter defenses to gain access to the control system network. Common points of access include:

- Dial-up access to remote terminal unit (RTU) devices.
- Supplier access points (such as technical support access points).
- IT-controlled network products.
- Corporate virtual private network (VPN).
- Database links.
- Poorly configured firewalls.
- Peer utilities.

Sources of Cyber Attacks

To submit a cybersecurity question, report security issues, or to get the latest news from Schneider Electric, visit our [Schneider Electric Country website](#).

	Safety information	4
	Safety precautions	5
	Cybersecurity	6
	Introduction	6
	Schneider Electric's Approach on Cybersecurity	6
	Cyber Threats	7
	Sources of Cyber Attacks	7
	How Attackers Gain Access	7
	Sources of Cyber Attacks	8
Chapter 1	Introduction	11
	PowerLogic Master Range	11
	Active Harmonic Filter	11
	Electronic VAR Control	11
Chapter 2	Receiving, handling, and storing	13
	Receiving	13
	Inspection	13
	Handling	14
	Storing	14
Chapter 3	Installation	15
	Foundation preparation	16
	Installation	16
	Environmental Requirements	16
	Physical Installation	17
	Physical Description	18
	Dimensional Drawings	19
	40...94 A Drawings	19
	133...235 A Drawings	21
	Attaching the Enclosure to the Floor	23
	Electrical Connection	25
	Line Voltage	25
	Circuit Breaker and Manual Disconnect Selection	25
	Residual Current Device	25
	Power Cable Routing	26
		26
	Power and Ground Cable Selection and Connections	27
	Power Termination Covers	29
	40...94 A Enclosure Internal Layout Drawing	30
	133...235 A Enclosure Internal Layout Drawing	31
	Current Transformers (CTs)	32
	General CT Information	32
	Minimum CT Requirements	33
	CT to CT Board Connection	34
	Maximum Wire Length	36
	Parallel System	38
	CT Installation Parallel Units	38
	Parallel Communication	43
	Control Wiring	44
	Dry Contact Output	44
	Digital Input Control	44
	Modbus TCP/IP	44
	Modbus Serial	45

Chapter 4	Pre-commissioning	49
	Instruments required for commissioning	49
	Pre-energizing procedure	49
	Installation Inspection	49
	Pre-Commissioning Checklist	50
	Commissioning procedures	50
Chapter 5	IT, HRG, and Corner Grounded Systems	51

Chapter 1 Introduction

The product can be provided in either of two types, an Active Harmonic Filter (AHF) or an Electronic VAR Control (EVC). Both types are to be installed as described in this manual. These products are both referred to as an active filter in this manual.

PowerLogic Master Range

PowerLogic smooths the power supply, helps to protect the network, the installation and the operator by improving the power factor and hence the quality of the power. It also allows for remote control of equipment and the monitoring of its performance and condition in real time.

Active Harmonic Filter

Active Harmonic Filters (AHF) are static power electronic products that employ digital logic and IGBT semiconductors to synthesize a current waveform that is injected into the electrical network to cancel harmonic currents caused by nonlinear loads. AHF employ current transformers to measure the load current to determine the content of harmonic current present. By injecting the synthesized current, network harmonic currents are greatly mitigated, thus reducing the heating effects of harmonic current and reducing voltage distortion.



AHF also have the ability to correct for poor displacement power factor (DPF) and for mains current balancing. DPF correction can be provided for either leading (capacitive) or lagging (inductive) loads that cause poor DPF. Mains current balancing is achieved by measuring the negative sequence current present and injecting the inverse negative sequence current to balance the current for the upstream network.

Electronic VAR Control

Electronic VAR control are static power electronic products that employ digital logic and IGBT semiconductors to synthesize a current waveform that is injected into the electrical network to cancel load induced poor displacement power factor, phase current unbalance, and flicker. DPF correction can be provided for either leading (capacitive) or lagging (inductive) loads that cause poor DPF. Mains current balancing is achieved by measuring the negative sequence current present and injecting the inverse negative sequence currents to balance the current for the network. Flicker control is provided by rapid detection and injection of reactive current (VARs) to help prevent the reactive current from over loading the network that causes rapid voltage deviations identified as flicker.

EVC also have the ability to monitor the network voltage on which they are connected and determine the proper amount of VARs to either raise the network voltage or lower it. EVC will inject leading VARs to raise the voltage and lagging VARs to lower the voltage. Entry of appropriate parameters will keep the network within its stated voltage tolerance level.

Chapter 2 Receiving, handling, and storing

⚠ WARNING		
		<p>TIP OVER HAZARD</p> <ul style="list-style-type: none"> • Read and apply user instructions before work <ul style="list-style-type: none"> ◦ Secure the product in place ◦ Secure the product if removing the securing bolts or moving the product ◦ Use appropriate lifting equipment • Use trained personnel only, who know and understand the user instructions <p>Failure to follow these instructions can result in death, serious injury, or product damage.</p>





 D3274504

Receiving

Inspect the active filter for any damage as soon as it is received. Transfer of the equipment to a carrier at any manufacturing plant or other shipping point constitutes delivery to the purchaser. Title and all risk of loss or damage in transit shall pass to the purchaser at that time, regardless of freight payment.

Inspection

- Check that all packages and/or crates have been delivered and that the equipment has not been damaged in transit.
- On the outside packaging and inside the unit, Tip N Tell and Drop N Tell monitoring devices are installed. If these have been activated, inform the carrier immediately.



- In the event of damaged or missing items, contact the carrier immediately. Check with them for time limits for filing claims and any documentation required such as a Bill of Lading number, etc.
- Goods, whether sent freight pre-paid or not, are shipped at the consignee's risk.
- Damaged or missing items are the responsibility of the carrier and must be reported.
- Check that the information shown on the equipment nameplates corresponds with the order specifications.
- The packaging material should be replaced to help protect the unit until installation has begun.

Handling

WARNING

HAZARD OF PERSONAL INJURY

- Use proper lifting equipment such as an overhead crane to handle the active filter.
- Do not lay the equipment on its front.

Failure to follow these instructions can result in death, serious injury, or equipment damage.

Ensure that the proper equipment such as an overhead crane is available at the installation site to handle the active filter. This equipment will help avoid injury to personnel and damage to the active filter.

Verify the lifting capacity of the equipment being used to handle the active filter in accordance with the shipping weight of each shipping section.

Storing

If the active filter is not to be installed when unpacked, it should be stored indoors in a clean, dry place. The storage temperature must be between -20 °C (-4 °F) and 60 °C (140 °F) with a maximum relative humidity of 85%, non-condensing, and a maximum dewpoint of 37 °C (98.6 °F). It is preferable to store the unit in its original shipping container to help protect the unit from potential damage.

Chapter 3 Installation

This chapter provides the information required to properly install the active filter and associated equipment for proper operation and performance. Frequently, commissioning difficulties are the result of incorrect wiring. Every precaution must be taken to make sure that the wiring is done as instructed. Read and understand all instructions in this manual prior to installation.

Correct installation of the active filter is essential for proper operation of all components. Study the associated instruction books and all drawings carefully.

The location chosen for installation should provide working clearances complying with the appropriate section of the National Electrical Code® (NEC®), the Canadian Electrical Code (CEC), or applicable local standards.

DANGER

HAZARD OF ELECTRIC SHOCK, EXPLOSION, OR ARC FLASH

- Apply appropriate personal protective equipment (PPE) and follow safe electrical work practices. See NFPA 70E in the USA, CSA Z462, or applicable local standards.
- This equipment must be installed and serviced only by qualified electrical personnel.
- Do not exceed the device's ratings for maximum limits.
- Ground equipment using the ground connecting point provided before turning on any power supplying this device.
- Turn off all power supplying this device and the equipment in which it is installed before working on the device or equipment.
- Do not stand on any part of the active filter.
- After removing power, wait for 15 minutes to allow the capacitors to discharge prior to opening the doors or removing covers.
- Always use a properly rated voltage sensing device to confirm power is off.
- Replace all devices, doors, and covers before turning on power to this equipment.
- Carefully inspect the interior for tools left behind before closing and sealing the door.

Failure to follow these instructions will result in death or serious injury.

The following is a summary of the steps for installation:

1. Make sure that the line voltage is compatible with the voltage rating of the active filter.
2. Make sure that the foundation is prepared for the active filter.
3. Make sure that environmental requirements are satisfied.
4. Refer to the dimensional drawings for the active filter to be installed.
5. Attach the enclosure to the floor.
6. Make the electrical connections.
7. Make the CT to CT board connection.

8. Set up parallel communication if applicable.
9. When installing on Isolated Terra (IT), High Resistance Ground (HRG), or corner grounded systems, ensure that the IT/BP switches are open. Refer to IT, HRG, and Corner Grounded Systems .
10. Make the control wiring connections, but do not energize the active filter yet.

NOTE: Commissioning and energizing the active filter requires specialized knowledge. Pre-commissioning procedures are covered in Pre-commissioning . Commissioning procedures are covered in the User Manual. Energize and commission the active filter only if you are qualified to do so.

Foundation preparation

The mounting location must be able to support the weight of the unit without sagging. Weight specifications are provided in UL Type 2, UL Type 12, IP31, and IP54 Enclosures Physical Specifications .

Installation

For optimum performance in harmonic mitigation mode, adhere to the following recommendations:

- All harmonic generating loads must have a minimum 3% line reactor or 3% DC choke installed.
- SCR based rectifiers are required to have a minimum 3% line reactor.
- No capacitors downstream of the Main CTs.

NOTICE

RISK OF EQUIPMENT DAMAGE

Adhere to DC choke, SCR based rectifier, and capacitor placement requirements.

Failure to follow this instruction can result in equipment damage.

If these recommendations are not followed, the target harmonic level may not be met and equipment damage can occur.

Environmental Requirements

Active filters are designed for indoor use only. They require unrestricted exchange of environmental air to the inside of the enclosure for proper cooling. Ensure that the environment meets Pollution Degree 2, i.e., does not contain conductive particles, significant amounts of dust, or corrosive or otherwise harmful gases. Normally only non-conductive pollution occurs. Temporary conductivity caused by condensation is to be expected.

NOTICE

RISK OF EQUIPMENT DAMAGE

Ensure that the installation location satisfies environmental requirements.

Failure to follow this instruction can result in equipment damage.

If environmental requirements are not adhered to, malfunction and possible destruction of the active filter may occur.

The active filter generates significant heat during operation. Consult the product specifications in Electrical Specifications for the watt losses for each active filter model. Ensure that the room where the active filter is mounted has adequate ventilation. Maintain ambient temperature between 0 °C (32 °F) and 40 °C (104 °F) with a maximum relative humidity of 95%, non-condensing, and a maximum dewpoint of 37 °C.

The operating temperatures are maximum and minimum levels the unit is designed to operate within. Operating above or below these levels will result in the unit either shutting down or reduced performance. The upper or lower limit should not be used as ideal room temperature levels. System reliability and product life expectancy will improve if temperature levels are maintained between 20 °C (68 °F) and 30 °C (86 °F).

Physical Installation

Active filters can be enclosed in four kinds of enclosures and are referred to as UL Type 2, UL Type 12, IP31, and IP54. These enclosures are suitable for an indoor installation only. The following table describes each type.

Enclosure Type	UL Type 2 IP31	UL Type 12 IP54
Enclosure provided	Yes	Yes
Standard Compliance: UL508	Yes	Yes
Standard Compliance: IEC 60529	Yes	Yes
Unrestricted air exchange, protection against contact with enclosed parts, protection against limited amount of falling dirt, intake of dust, and harmful particles	Yes	Yes
Protection against foreign bodies of these diameters	Yes >2.5 mm	Yes >1 mm
Protection against touch	Yes	Yes
Protection against dust	No	Yes
Protection against dripping water and external condensation of non-corrosive liquids	Yes	Yes
Protection against water from all directions	No	Yes

NOTE: This list indicates minimum requirements. Complete descriptions of the requirements are provided in the standards referenced in this list.

Physical Description

UL Type 2, UL Type 12, IP31, and IP54 Enclosures Physical Specifications

Active filter	Enclosure	Weight Kg (lbs)	Cable Entry	Operating Temperature	Heat Load (Watts)	Exterior Dimensions H x W x D mm (inches)
40 A	UL Type 2/IP31	483 (1062.6)	Top or Bottom	0...40°C (32...104°F)	2107	2,089 x 1300 x 550 (82.24 x 51.18 x 21.65)
	UL Type 12/ IP54	494 (1086.8)				
47 A	UL Type 2/IP31	460 (1012)	Top or Bottom	0...40°C (32...104°F)	1807	2,089 x 1300 x 550 (82.24 x 51.18 x 21.65)
	UL Type 12/ IP54	471 (1036.2)				
80 A	UL Type 2/IP31	533 (1172.6)	Top or Bottom	0...40°C (32...104°F)	4503	2,089 x 1300 x 550 (82.24 x 51.18 x 21.65)
	UL Type 12/ IP54	542 (1192.4)				
94 A	UL Type 2/IP31	498 (1095.6)	Top or Bottom	0...40°C (32...104°F)	3903	2,089 x 1300 x 550 (82.24 x 51.18 x 21.65)
	UL Type 12/ IP54	507 (1115.4)				
133 A	UL Type 2/IP31	708 (1557.6)	Top or Bottom	0...40°C (32...104°F)	8213	2091 x 1400 x 653 (82.32 x 55.12 x 25.71)
	UL Type 12/ IP54	730 (1606.0)				
157 A	UL Type 2/IP31	653 (1436.6)	Top or Bottom	0...40°C (32...104°F)	7213	2091 x 1400 x 653 (82.32 x 55.12 x 25.71)
	UL Type 12/ IP54	675 (1485.0)				
200 A	UL Type 2/IP31	826 (1817.2)	Top or Bottom	0...40°C (32...104°F)	11,398	2091 x 1400 x 653 (82.32 x 55.12 x 25.71)
	UL Type 12/ IP54	839 (1845.8)				
235 A	UL Type 2/IP31	757 (1665.4)	Top or Bottom	0...40°C (32...104°F)	9898	2091 x 1400 x 653 (82.32 x 55.12 x 25.71)
	UL Type 12/ IP54	770 (1694.0)				

NOTE:

- Weight information is approximate and subject to change without notice.
- Lifting lugs are provided for hoisting.

Dimensional Drawings

Refer to the drawings on the following pages for active filter dimensions.

40...94 A Drawings

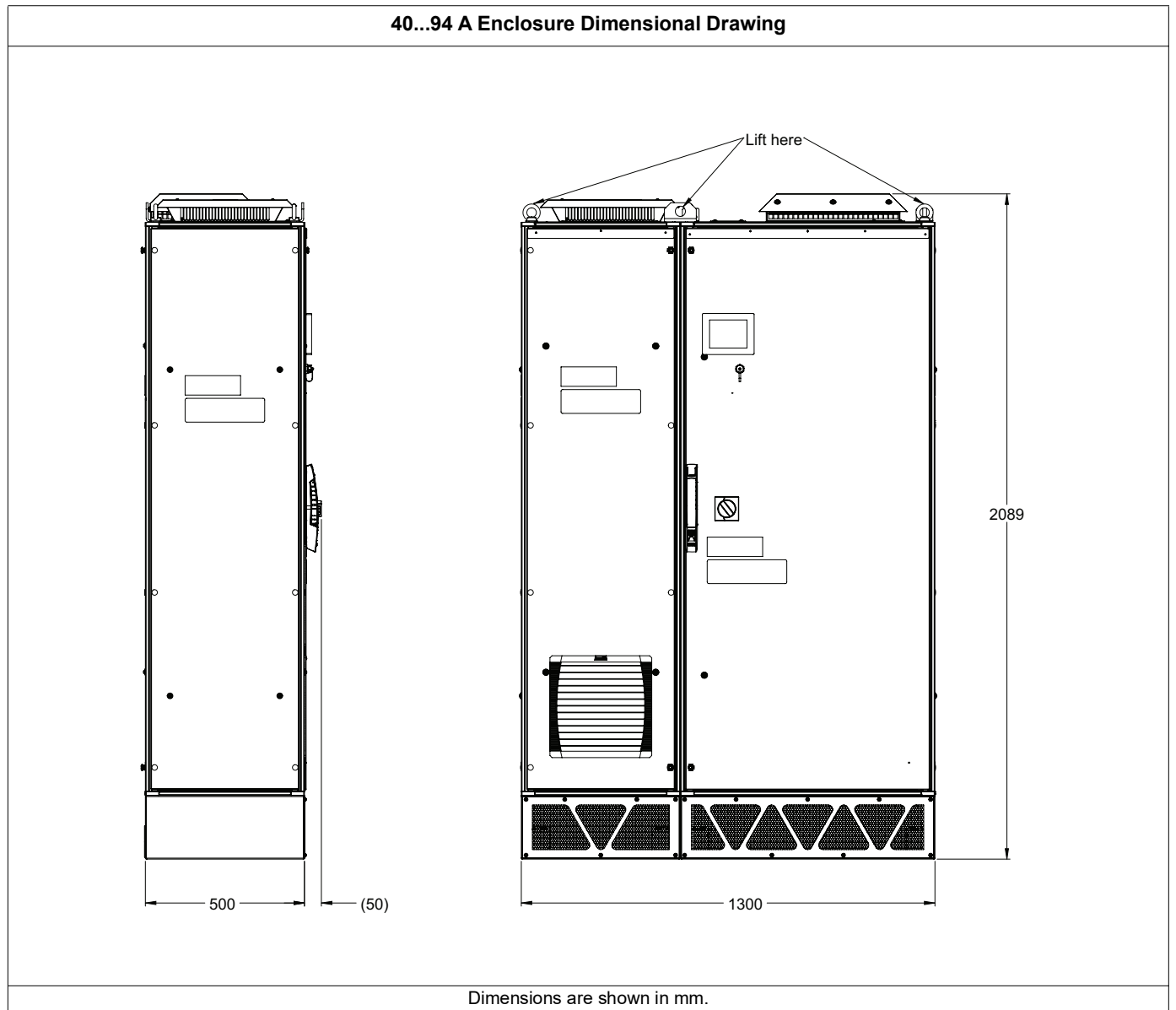

NOTE: The diagram is of an IP54 model. The IP31 models do not have air intake vents on the door.

40...94 A Enclosure Top and Bottom Dimensional Drawing

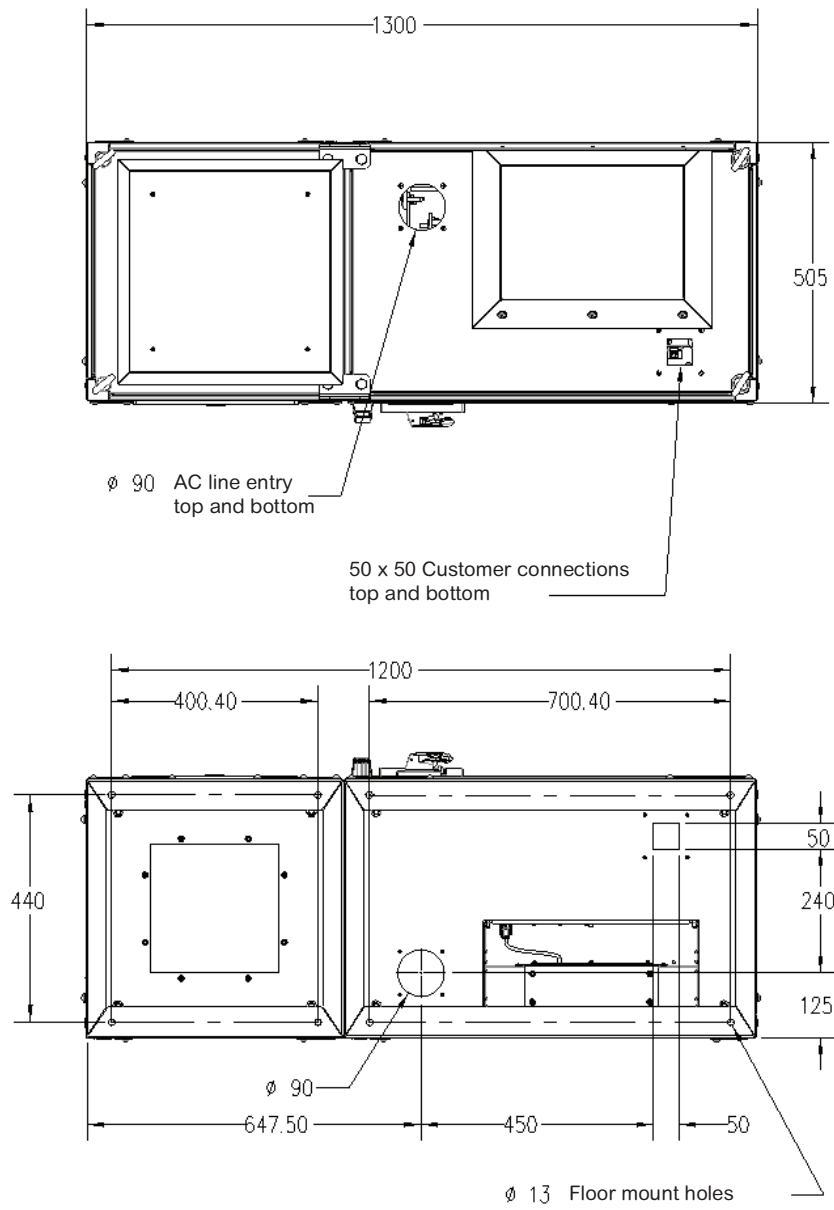

Dimensions are shown in mm.

133...235 A Drawings

133...235 A Enclosure Dimensional Drawing

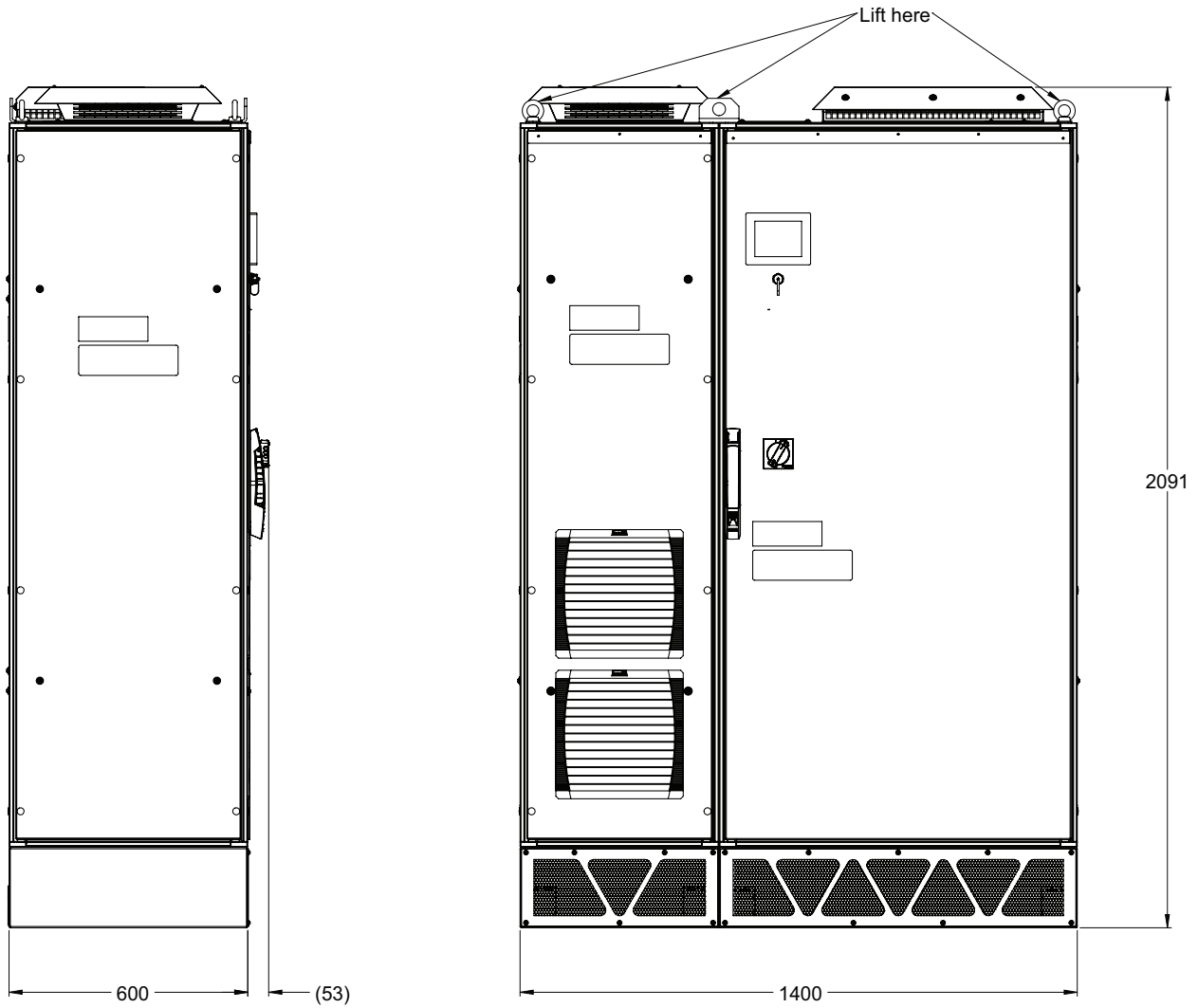

Dimensions are shown in mm.

NOTE: The diagram is of an IP54 model. The IP31 models do not have air intake vents on the door.

133...235 A Enclosure Top and Bottom Dimensional Drawing

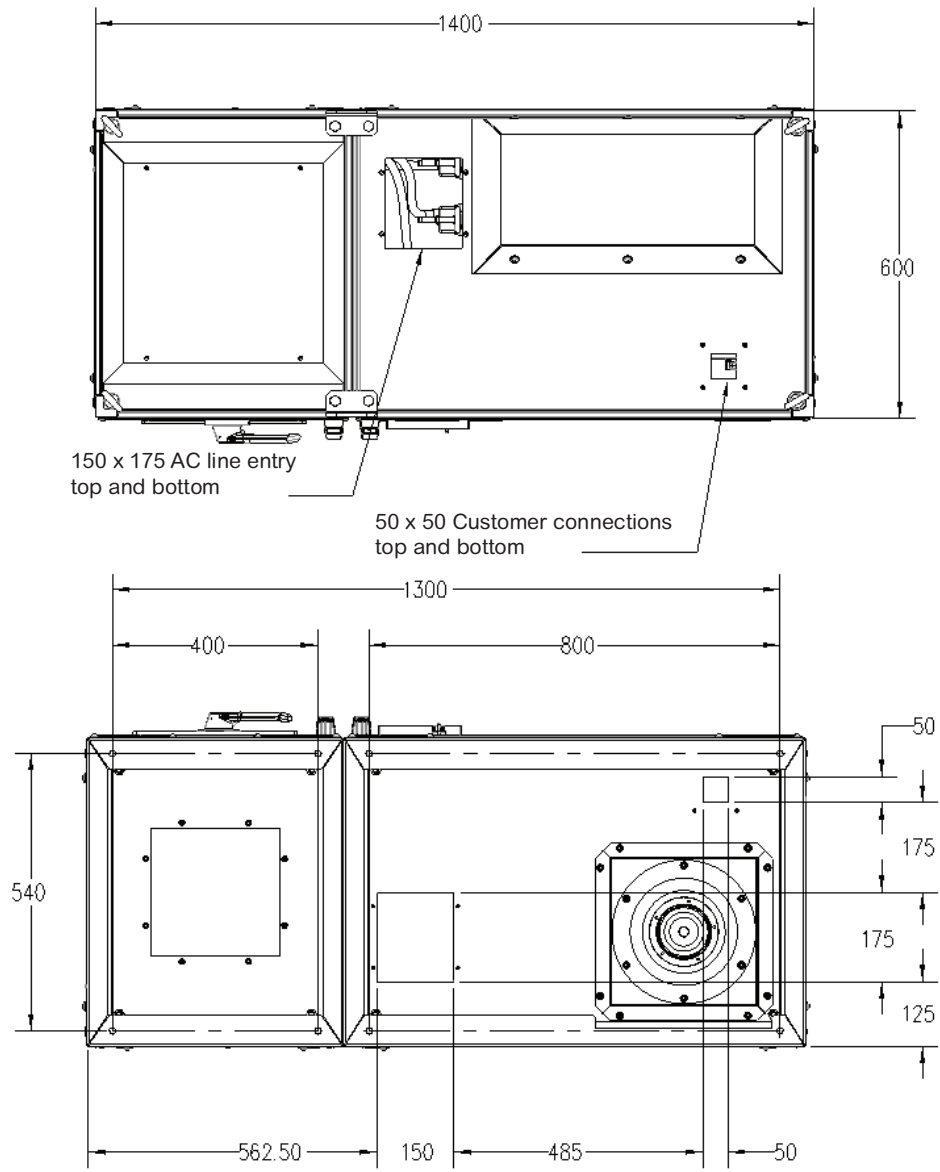

Dimensions are shown in mm.

Attaching the Enclosure to the Floor

⚠ WARNING

RISK OF THE ENCLOSURE FALLING

Attach the equipment to the floor using the attachment points indicated below.

Failure to follow these instructions can result in death, serious injury or equipment damage.

The unit must be securely attached to the floor where it is installed, using eight M12 size the like anchor bolt and expansion bolt.

NOTE: M12 size bolts are not included in the packaging box.

Floor Attachment Point Locations

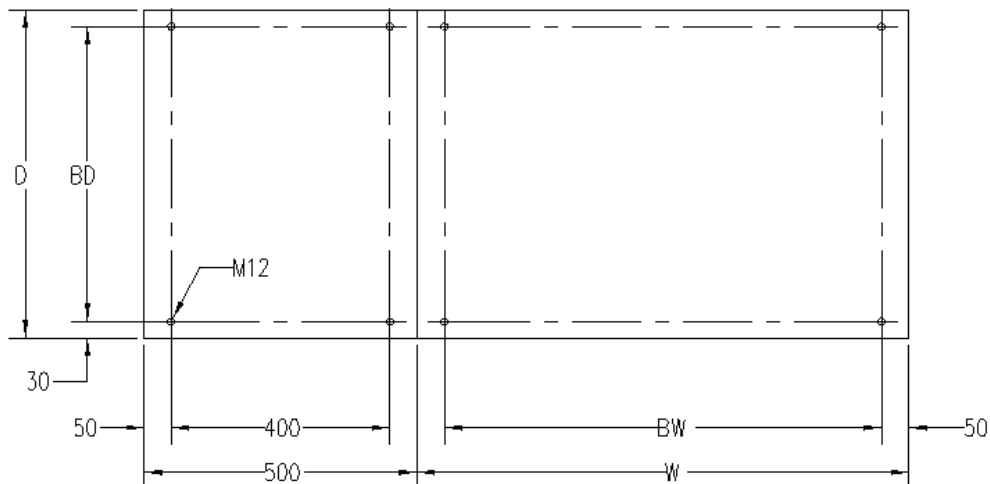

Dimensions

Amperage Rating	BD mm (in)	D mm (in)	BW mm (in)	W mm (in)
40... 94 A	440 (17.32)	500 (19.69)	700 (27.55)	800 (31.50)
133...235 A	540 (21.26)	600 (23.62)	800 (31.50)	900 (35.43)

Refer to the illustration and the table above for the dimensions and attachment locations for the enclosure you are installing and follow these steps:

1. Make sure that the location is large enough for the enclosure.
2. Drill holes in the locations for the unit you are installing.
3. Position the equipment in its location.

4. Remove the four plinth access covers at the front of the plinth by loosening the four M6 screws using a T30 driver.

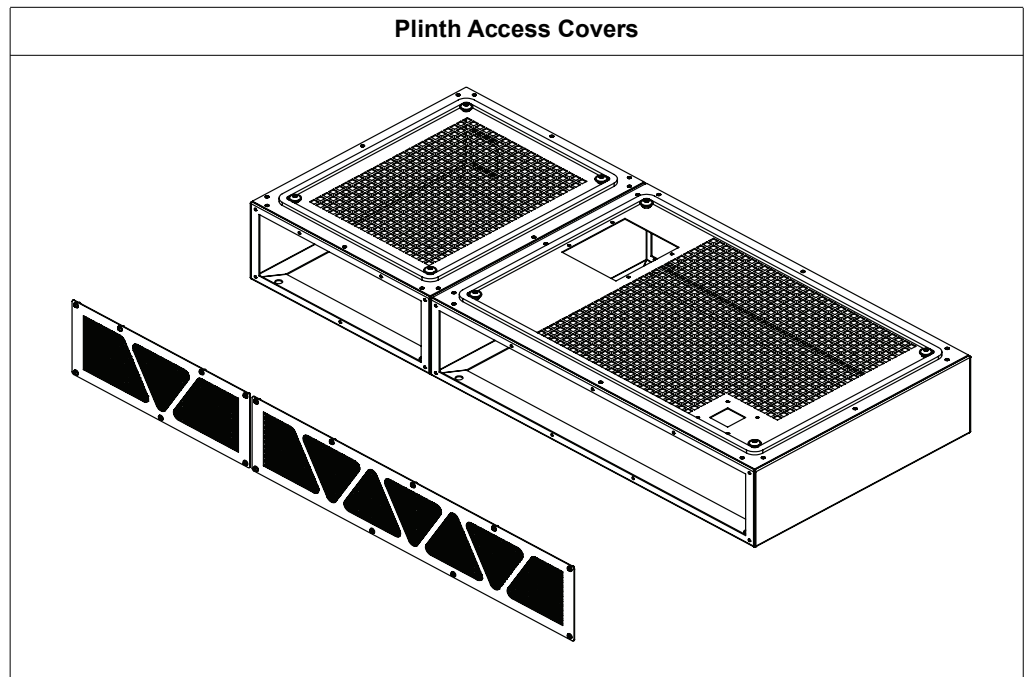

5. Secure the unit to the floor using mounting hardware.
6. Replace the front access covers and torque the screws to 5.7 Nm (50.4 lb-in).

Electrical Connection

Line Voltage

Refer to Electrical Specifications to determine the line voltage that is compatible with the voltage range of the active filter.

Circuit Breaker and Manual Disconnect Selection

A dedicated over-current protection device, circuit breaker, or fuse disconnect is required for this product. The over-current protection device must be rated for at least 125% of the unit rating.

The active filter inrush current does not exceed the unit rating shown in the following table. Circuit breaker settings such as Long Time Pickup, Long Time Delay, and Short Time Pickup can be set for minimum inrush current.

Amperage Rating	Voltage Rating	Minimum Circuit Ampacity	Minimum Circuit Breaker Size	Recommended Fuse / Circuit Breaker Size
40 A	600...690 V	40 A	50 A	80 A
47 A	500...600 V	47 A	59 A	80 A
80 A	600...690 V	80 A	100 A	150 A (UL) / 160 A (IEC)
94 A	500...600 V	94 A	118 A	150 A (UL) / 160 A (IEC)
133 A	600...690 V	133 A	166 A	200 A
157 A	500...600 V	157 A	196 A	200 A
200 A	600...690 V	200 A	250 A	250 A
235 A	500...600 V	235 A	294 A	300 A

NOTE: Check national and local codes and regulations to ensure compliance.

Residual Current Device

NOTICE

INAPPROPRIATE TRIPPING OF PROTECTION DEVICE

Adhere to the Residual Current Device (RCD/GFCI) and Residual Current Monitor (RCM) requirements.

Failure to follow this instruction can result in a reduction in performance of the PowerLogic™ AccuSine active filter.

Direct current can be introduced in the protective ground conductor of the PowerLogic™ AccuSine active filter. If a RCD/GFCI or a RCM is used for additional protection against direct or indirect contact, the following specific types must be used:

- Use only Type B RCD/GFCI.
- RCD/GFCI with time delay set to 100 ms or greater.
- For parallel systems, provide one RCD/GFCI per unit.
- RCM must be approved for use with frequency inverters and is sensitive to all types of current.

Due to high leakage current in standard operation, it is recommended to choose at least a 500 mA device. If the installation requires a residual current device less than 500 mA, the IT/BP switches must be opened. (For more information, refer section IT, HRG, and Corner Grounded Systems).

Power Cable Routing

Power cables connection to the active filter must be according to the local code to help reduce noise coupling (EMI). Entry for all power cables has to be made through the removable gland plates on the bottom or top of the active filter enclosure.

NOTE: In case of North America, the power cables must be placed in metal conduit or shielded encapsulated cables.

See 40...94 A Enclosure Top and Bottom Dimensional Drawing and 133...235 A Enclosure Top and Bottom Dimensional Drawing .

For all power systems, observe the following:

- Metal conduit or the encapsulated cable shield has to be grounded to the active filter ground-terminal located adjacent to the power terminals.
- All panels must be installed to ensure proper system cooling.

NOTICE

RISK OF CONTAMINATION BY CONDUCTIVE MATERIAL OR DEBRIS

- Remove conduit entry gland plates to drill cable entry holes.
- The active filter warranty is void if operational difficulties are found to be caused by metal particles from the installation process.

Failure to follow this instruction can result in equipment damage.

Power and Ground Cable Selection and Connections

DANGER

HAZARD OF ELECTRIC SHOCK, EXPLOSION, OR ARC FLASH

Ground equipment using the ground connecting point provided before turning on any power supplying this device.

Failure to follow these instructions will result in death or serious injury.

All power wiring has to be routed directly from the conduit entry plate to the terminations on power terminals (and the earth grounding terminal) without loops. Instrumentation and CT wiring has to be routed in a separate conduit to the power cables. A dedicated ground conductor must be used when installing the active filter.

NOTE:

- Metal conduit shall be grounded or use shielded encapsulated cable.
- All wiring must follow the local wiring code.

When used as a harmonic current compensation device, the active filter produces currents at frequencies that are multiples of the AC line fundamental frequency. Power cables as well as input disconnect devices should be rated at 125% of the active filter rated current. This helps avoid excessive heating from any skin effect resistance increase at these higher frequencies.

NOTE: Check national and local codes and regulations to ensure compliance.

M8 power and ground studs are provided for the 40 A, 47 A, 80 A, and 94 A rated units. M12 power and M8 ground studs are provided for the 133 A, 157 A, 200 A, and 235 A units. The bus bar for power connection has two studs that can accept either a two-hole crimp lug or a two-hole box lug. The bus bar studs are 25.4 mm (1 in) apart center-to-center. See 40...94 A Enclosure Internal Layout Drawing and 133...235 A Enclosure Internal Layout Drawing for details.

Box lug accessory kits are available as an option in the catalog. The box lugs are UL compliant. Each kit contains three box lugs for the phase connection and one box lug for the ground connection. When installing 133 A to 235 A units, two box lug kits are required per unit if two conductors per phase are used.

The box lugs in the optional accessory kit are not IEC compliant. For IEC installation, use crimp-on ring lugs for electrical connections.

Electrical Specifications

Active Filter	Total Current Amperes(A)	Voltage Range Volts(V)	Frequency Hz	Wire Temperature Rating	Intake Air Temperature	Power Connection Stud Size and Torque N•m (lb-in) ± 5%	Ground Connection Stud Size and Torque N•m (lb-in) ± 5%	Max. No. Conductors Per Phase
40 A Enclosures N12, IP30, and IP54	40	600...690	50 or 60 Hz ±3 Hz	60 °C, 75 °C, 90 °C	0...40 °C (32...104 °F)	M8 stud - 18.2 (161.1)	M8 stud - 18.2 (161.1)	1
47 A Enclosures N12, IP30, and IP54	47	500...600	50 or 60 Hz ±3 Hz	60 °C, 75 °C, 90 °C	0...40 °C (32...104 °F)	M8 stud - 18.2 (161.1)	M8 stud - 18.2 (161.1)	1
80 A Enclosures N12, IP30, and IP54	80	600...690	50 or 60 Hz ±3 Hz	75 °C, 90 °C	0...40 °C (32...104 °F)	M8 stud - 18.2 (161.1)	M8 stud - 18.2 (161.1)	1
94 A Enclosures N12, IP30, and IP54	94	500...600	50 or 60 Hz ±3 Hz	75 °C, 90 °C	0...40 °C (32...104 °F)	M8 stud - 18.2 (161.1)	M8 stud - 18.2 (161.1)	1
133 A Enclosure Type N1 and Chassis	133	600...690	50 or 60 Hz ±3 Hz	75 °C, 90 °C	0...40 °C (32...104 °F)	M12 stud - 37.0 (327.5)	M8 stud - 18.2 (161.1)	2
157 A Enclosure Type N1 and Chassis	157	500...600	50 or 60 Hz ±3 Hz	75 °C, 90 °C	0...40 °C (32...104 °F)	M12 stud - 37.0 (327.5)	M8 stud - 18.2 (161.1)	2
200 A Enclosures N12, IP30, and IP54	200	600...690	50 or 60 Hz ±3 Hz	75 °C, 90 °C	0...40 °C (32...104 °F)	M12 stud - 37.0 (327.5)	M8 stud - 18.2 (161.1)	2
235 A Enclosures N12, IP30, and IP54	235	500...600	50 or 60 Hz ±3 Hz	75 °C, 90 °C	0...40 °C (32...104 °F)	M12 stud - 37.0 (327.5)	M8 stud - 18.2 (161.1)	2

NOTE:

- Check national and local codes and regulations to ensure compliance.
- The active filter generates significant heat during operation. Ensure that the room where the active filter is located has adequate ventilation to maintain intake air temperature within the specified operating range.

Power Termination Covers

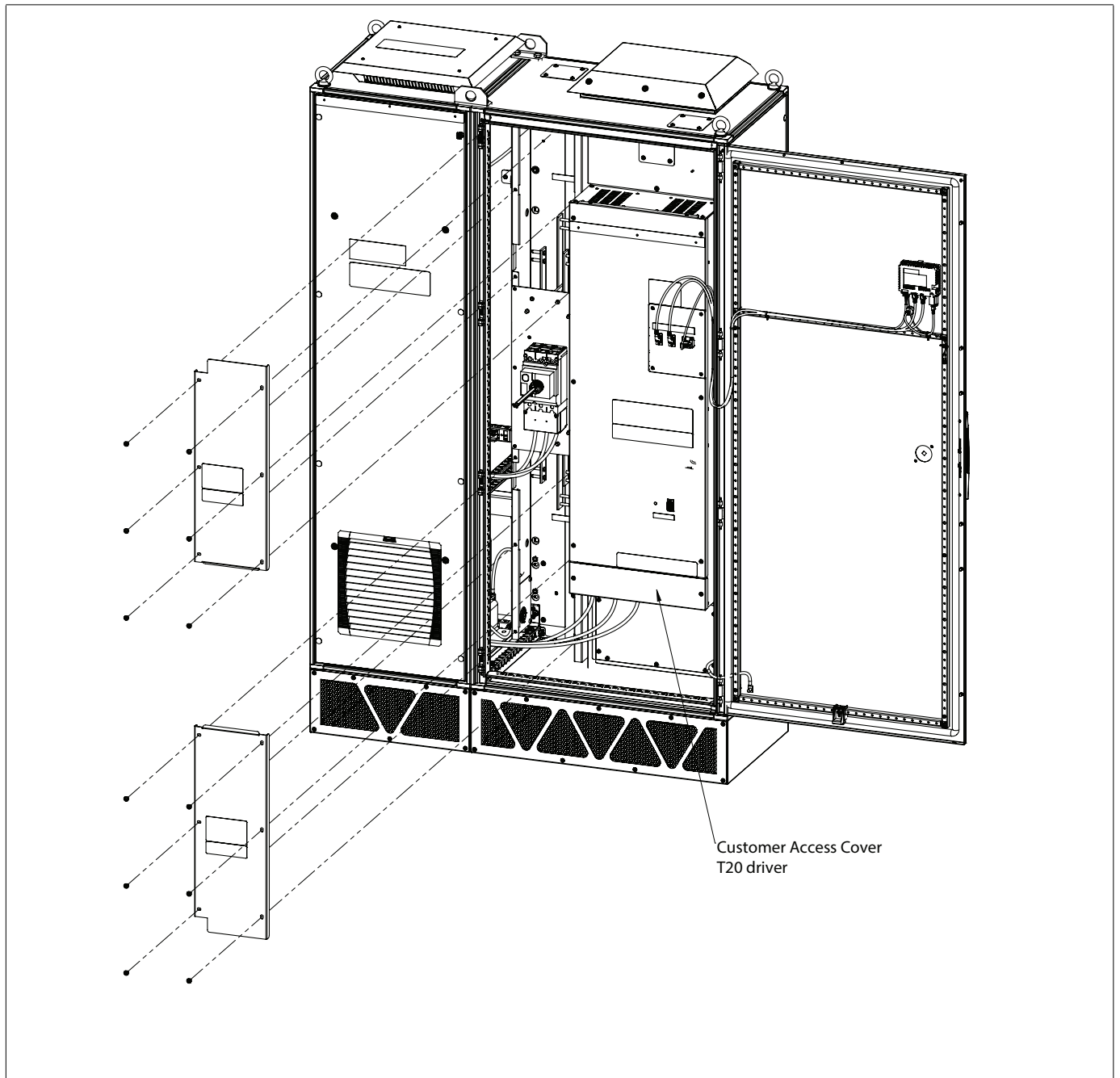

40...94 A Enclosure Internal Layout Drawing

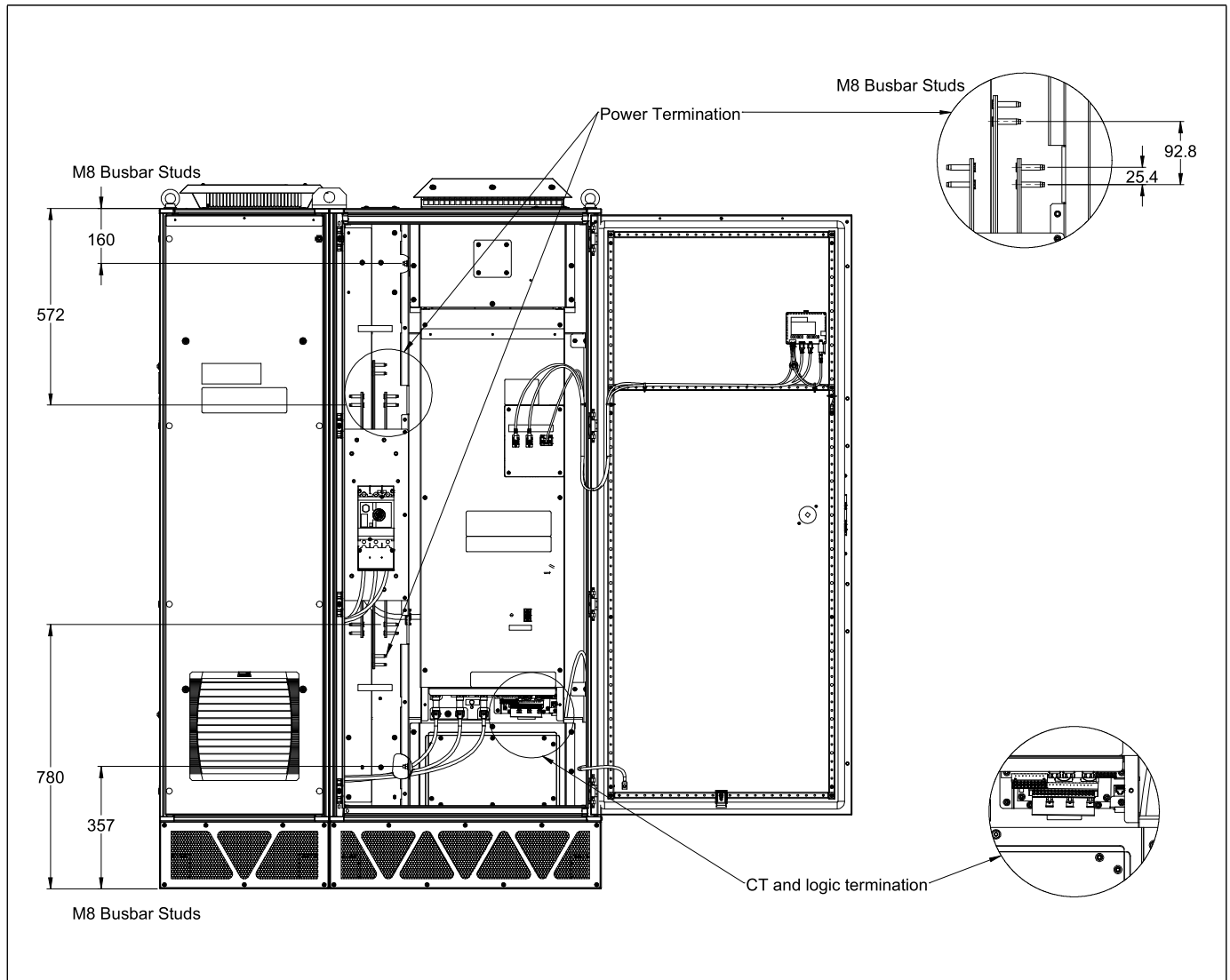

133...235 A Enclosure Internal Layout Drawing

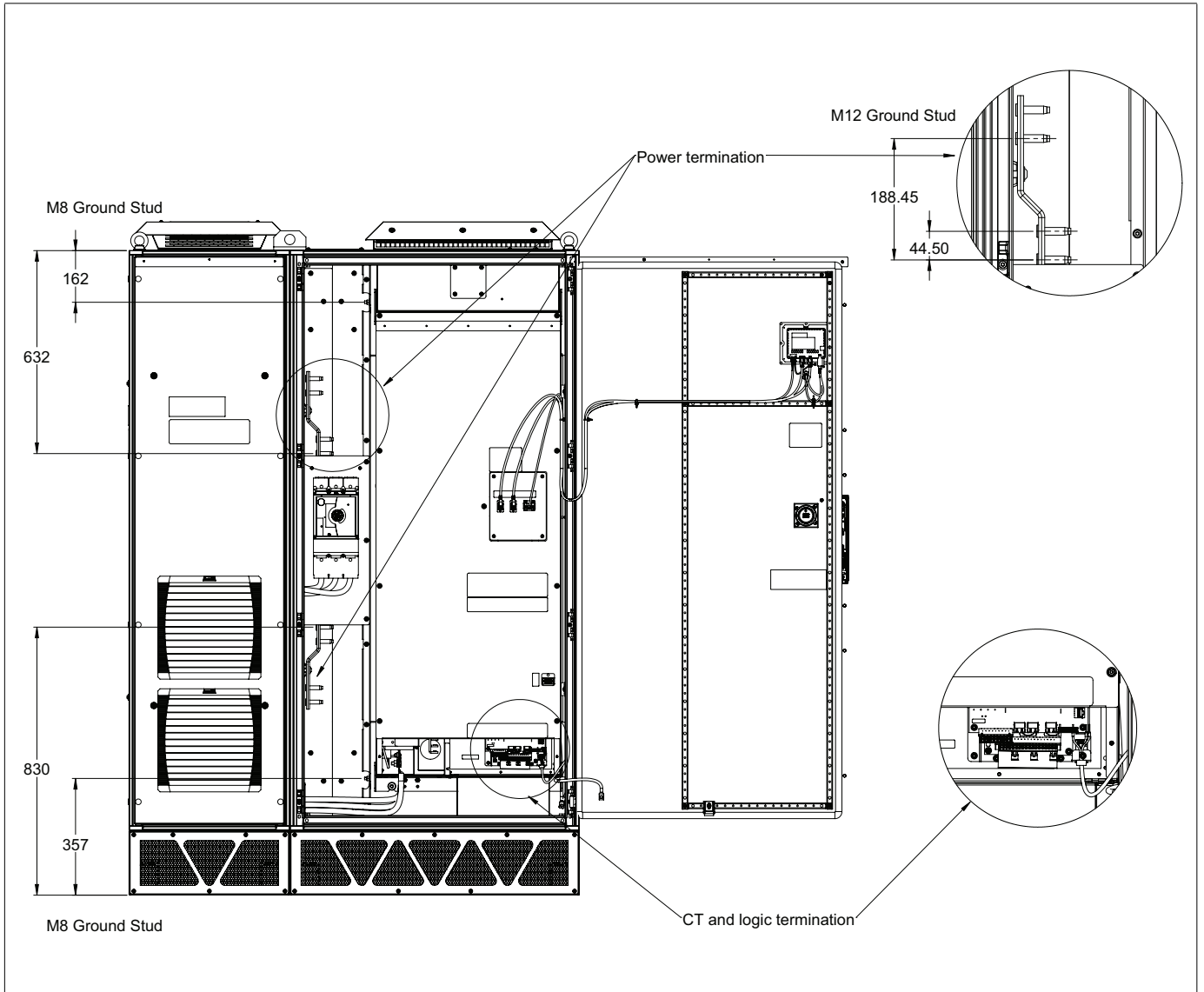

Current Transformers (CTs)

DANGER

HAZARD OF ELECTRIC SHOCK, EXPLOSION, OR ARC FLASH

- Never open circuit a current transformer (CT).
- Always use grounded external CTs for current inputs.

Failure to follow these instructions will result in death or serious injury.

Ensure that CT secondary current is not present when wiring the CT secondary connections. The shorting jumpers must be installed at the X1 to X2 OUT of each CT channel on the CT board unless you are connecting an additional Primary parallel unit. Refer to Source Side CT Position Diagram .

General CT Information

The CT must be orientated properly during installation. The orientation is specified in the drawings with an arrow indicating the direction or polarity of the CT. Most CT manufacturers will indicate orientation with a label indicating H1 on one side of the CT or a dot. There can also be a label indicating H2 and/or an arrow on the CT. The H1 side of the CT should always be closest to the power source. If the CT has an orientation arrow, it should point from the source towards the load. See the installation instructions for the specific CTs being installed.

A shorting terminal block or shorting switch with galvanic isolation to the active filter for the CT secondary is required. Insert an interposing terminal block in a separate enclosure with the ability to short the secondary wiring of the CT. This provides the ability to short the CT without entering the active filter enclosure (which otherwise would require a power shutdown). Shorting terminal blocks are available in the catalog.

CT location is defined in relationship to the active filter system. CT location on the “Source Side” indicates that the CTs are physically located upstream of the active filter. The CTs will measure the improvement to the current as a result of the active filter operating. A CT location on the “Load Side” indicates that the CTs are downstream of the active filter. The CTs will monitor the Load current provided by both the source and active filter currents.

Two CTs are required to be installed, one on L1 phase and one on L2 phase of the conductors powering the loads to be compensated by the active filter system. If there are any line-to-neutral connected loads downstream of the active filter system's main CTs, a third CT is required on L3 phase.

NOTICE

MEASUREMENT ERRORS

CTs must be physically separated from any perpendicular conductor by at least 25 mm (1 inch) for every 1000 A of current flowing through the perpendicular conductor.

Failure to follow this instruction can result in a reduction in performance of the active filter.

If this practice is not followed, the magnetic field produced by the current flowing on the perpendicular conductor will cause CT measurement errors.

Minimum CT Requirements

The active filter uses a minimum of two external current transformers (CTs) to measure load current waveforms. Standard CTs rated for 50/60 Hz or 400 Hz with Type 1 accuracy rating, with a 5 A or 1 A secondary are acceptable. The largest primary rating for the CT is 10,000 A. Any splicing to the CT leads needs to be done with crimp style connectors or soldered.

The CT should be mounted on phases L1 and L2 with the orientation arrow pointing toward the load. Systems that are using two CTs can have the CTs installed on L1 and L3 or L2 and L3 if necessary. If L1 and L3 or, L2 and L3 CT configurations are used, this information must be provided to the qualified person commissioning the unit. Three external CTs are required if line-to-neutral connected loads are present.

NOTICE

REDUCED PERFORMANCE

CT wiring must be routed separately from power cables.

Failure to follow this instruction can result in a reduction in performance.

CT wiring must be routed directly from the conduit entry-plate to the terminal block of the CT board.

CT must be selected for:

- 5 A or 1 A secondary
- 250 A to 10,000 A primary rating
- 50/60 Hz or 400 Hz Rated
- Type 1 accuracy
- The CT primary current rating, which must exceed the maximum load current where they are installed.
- The maximum burden (in VA) on the CT is formed by the CT wiring and total active filter burden. This is equal to 1.0 VA for CTs with a 5 A secondary rating or 0.04 VA for CTs with a 1 A secondary rating.
- The maximum wire size of the CT secondary is 2.5 mm² / 12 AWG. Consult the CT manufacturer for secondary wiring recommendations. See Maximum Wire Length tables.

CT secondary wiring must be either twisted and/or shielded pairs

Do not connect the active filter CT to any other loads. Use a separate current transformer if additional uses are required.

Any splicing to the CT leads needs to be done with crimp style connectors or soldered.

X2 of each CT installed must be grounded as close to the CT as possible.

A single active filter, not operating in parallel, can have the CTs installed either on the source side or load side of the active filter. Parallel systems must have the main CTs installed on the source side of the active filter system.

CT to CT Board Connection

The CT connection is made behind the small customer access panel at the bottom of the active filter chassis. Remove the customer access panel. The CT board is located behind and slightly below the control board. This is the location where the active filter CT secondary wiring must be terminated. Remove the clear plastic safety cover to access the CT board.

Typically, L1 CT will be connected to CH1 IN. There are two X1 and X2 IN terminals. The second set of IN terminals can be used to connect additional CTs that may be required for site specific conditions. X1 and X2 OUT are used for parallel active filter systems.

NOTICE

CIRCULATING CURRENTS

When using shielded CT secondary wire, ground the shield in only one location.

Failure to follow this instruction can result in a reduction in performance.

NOTICE

INACCURATE FILTER OPERATION

Do not allow the conductor on which the CT is mounted to become lodged in the joint area of a split-core CT.

Failure to follow this instruction can result in inaccurate filter operation.

DANGER

HAZARD OF ELECTRIC SHOCK, EXPLOSION, OR ARC FLASH

The factory provided shorting jumpers must be installed at the OUT of the CT board of the last unit with CT secondary wiring connected.

Failure to follow these instructions will result in death or serious injury.

Control Board and CT Board Detail

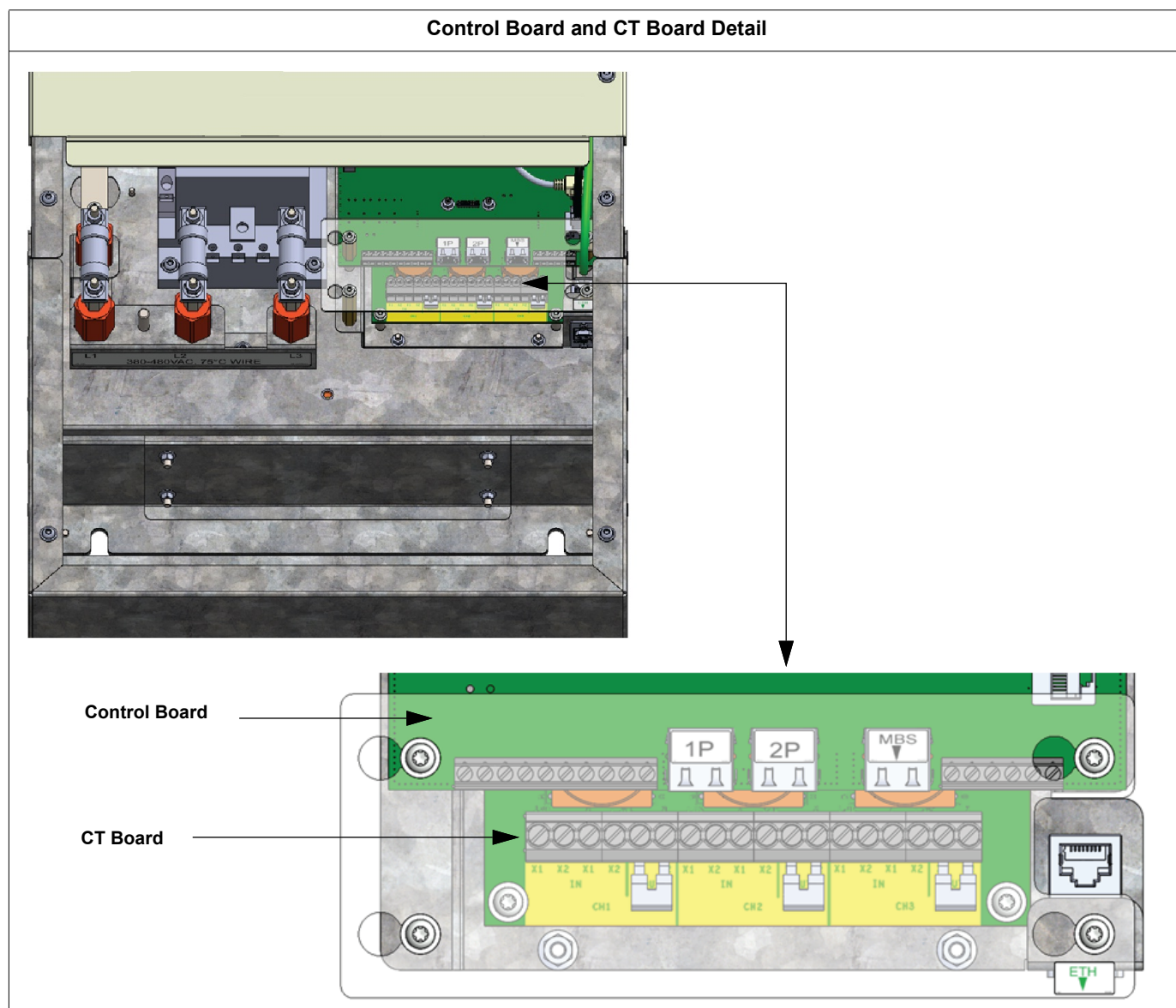

The terminal block on the CT board can accept wire sizes of up to 2.5 mm² (12 AWG) wire and has a torque specification of 1 N•m (9 lb-in).

Maximum Wire Length

5 A Secondary Maximum Wire Length

Maximum wire length from active filter to CT in meters		
CTs burden capacity with 5 A secondary rating	1.5 mm ²	2.5 mm ²
5 VA	15	24
15 VA	51	84
25 VA	87	143
30 VA	105	173
35 VA	124	203
45 VA	160	263

Maximum wire length from active filter to CT in feet		
CTs burden capacity with 5 A secondary rating	14 AWG	12 AWG
5 VA	65	103
15 VA	228	361
25 VA	390	619
30 VA	472	748
35 VA	553	877
45 VA	715	1135

1 A Secondary Maximum Wire Length

Maximum wire length from active filter to CT in meters		
CTs burden capacity with 1 A secondary rating	1.5 mm ²	2.5 mm ²
5 VA	451	740
15 VA	1360	2233
25 VA	2269	3725
30 VA	2724	4472
35 VA	3178	5218
45 VA	4087	6710

Maximum wire length from active filter to CT in feet		
CTs burden capacity with 1 A secondary rating	14 AWG	12 AWG
5 VA	2016	3200
15 VA	6081	9652
25 VA	10146	16103
30 VA	12179	19329
35 VA	14211	22555
45 VA	18276	29006

Source Side CT Position Diagram
(CTs installed on the "Source Side" or upstream of the active filter)

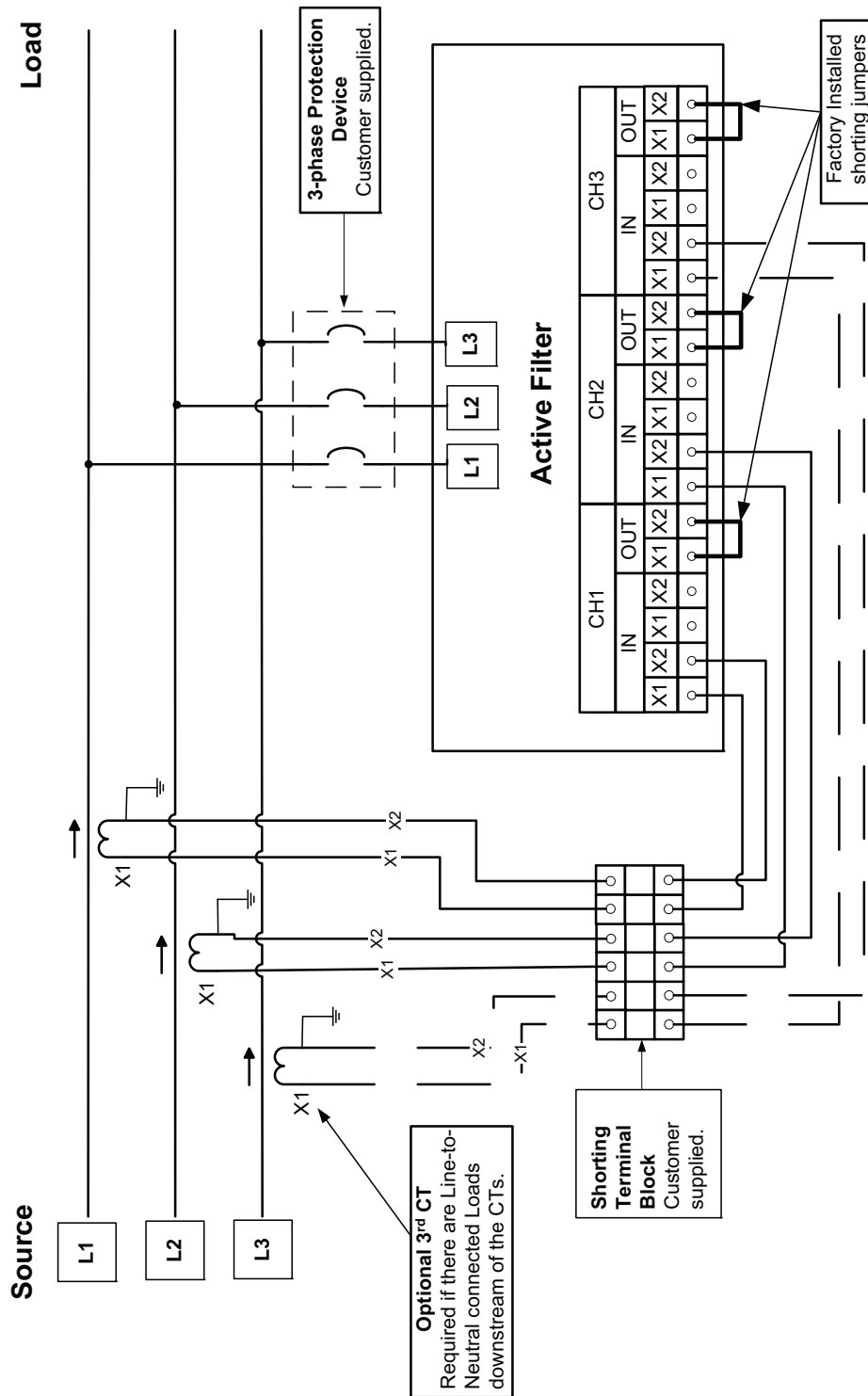

NOTE: The factory installed shorting jumpers must be installed.

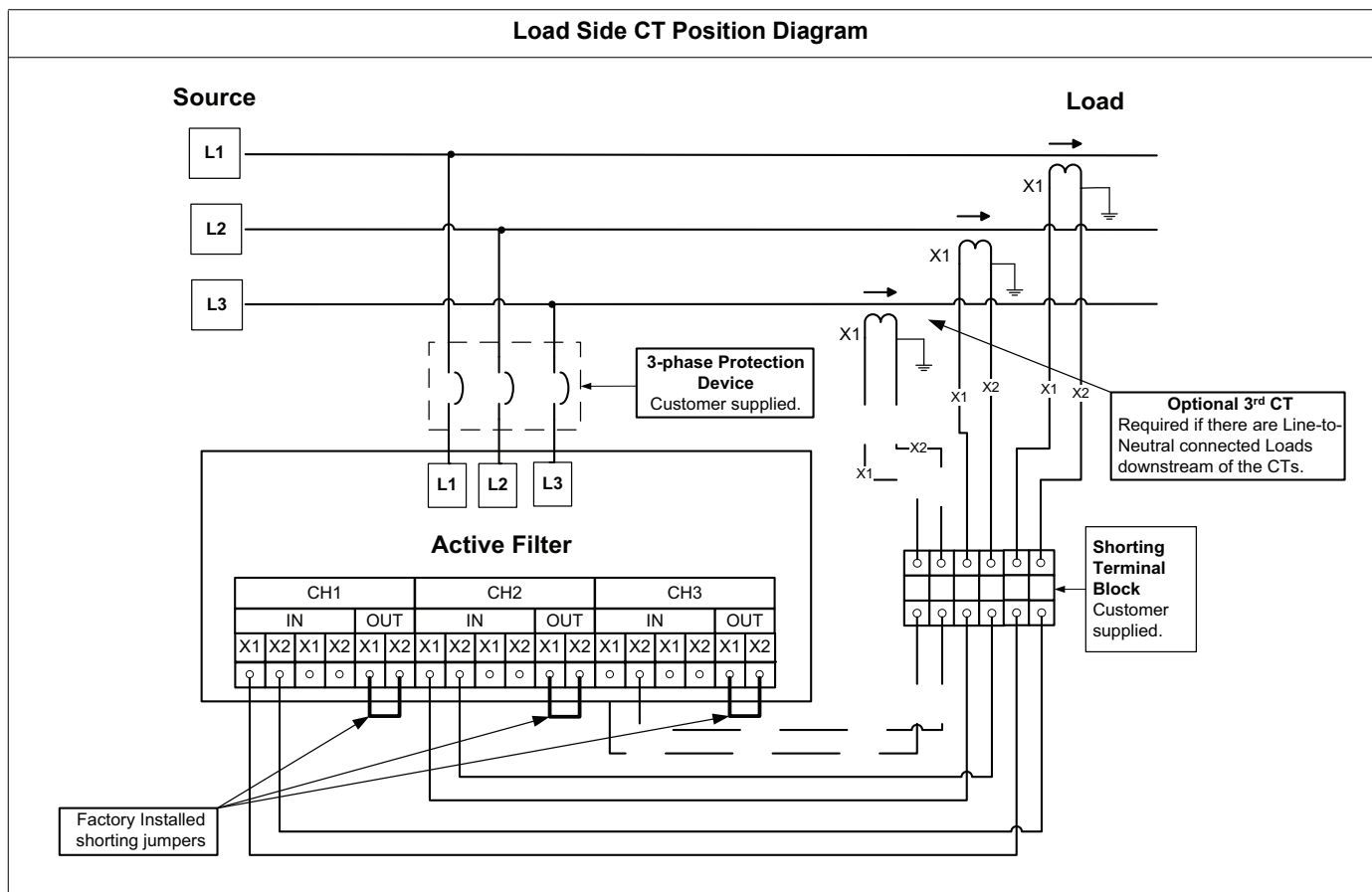

NOTE: The factory installed shorting jumpers must be installed.

Parallel System

Up to ten active filters can be installed in parallel. If more than ten units in parallel are required, contact the local sales representative for assistance prior to installation.

CT Installation Parallel Units

⚡ ⚠ DANGER

HAZARD OF ELECTRIC SHOCK, EXPLOSION, OR ARC FLASH

The factory provided shorting jumpers must be installed at the OUT of the CT board of the last unit with CT secondary wiring connected.

Failure to follow these instructions will result in death or serious injury.

The active filters can be set up to be either Primary or Follower. To be a candidate as a Primary, the unit must be provided with CT secondary wiring to the CT board. See Control Board and CT Board Detail . There is no limit to the number of units that can be set up as a Primary candidate. At least two units should be capable of being the Primary in any parallel installation.

The main CTs must be installed on the source side of the parallel active filter system. Examples of CT secondary wiring can be seen on the following pages in this section. Refer to Circuit Breaker and Manual Disconnect Selection for information on circuit breaker and fuses required.

CT Wiring for 3 Primaries

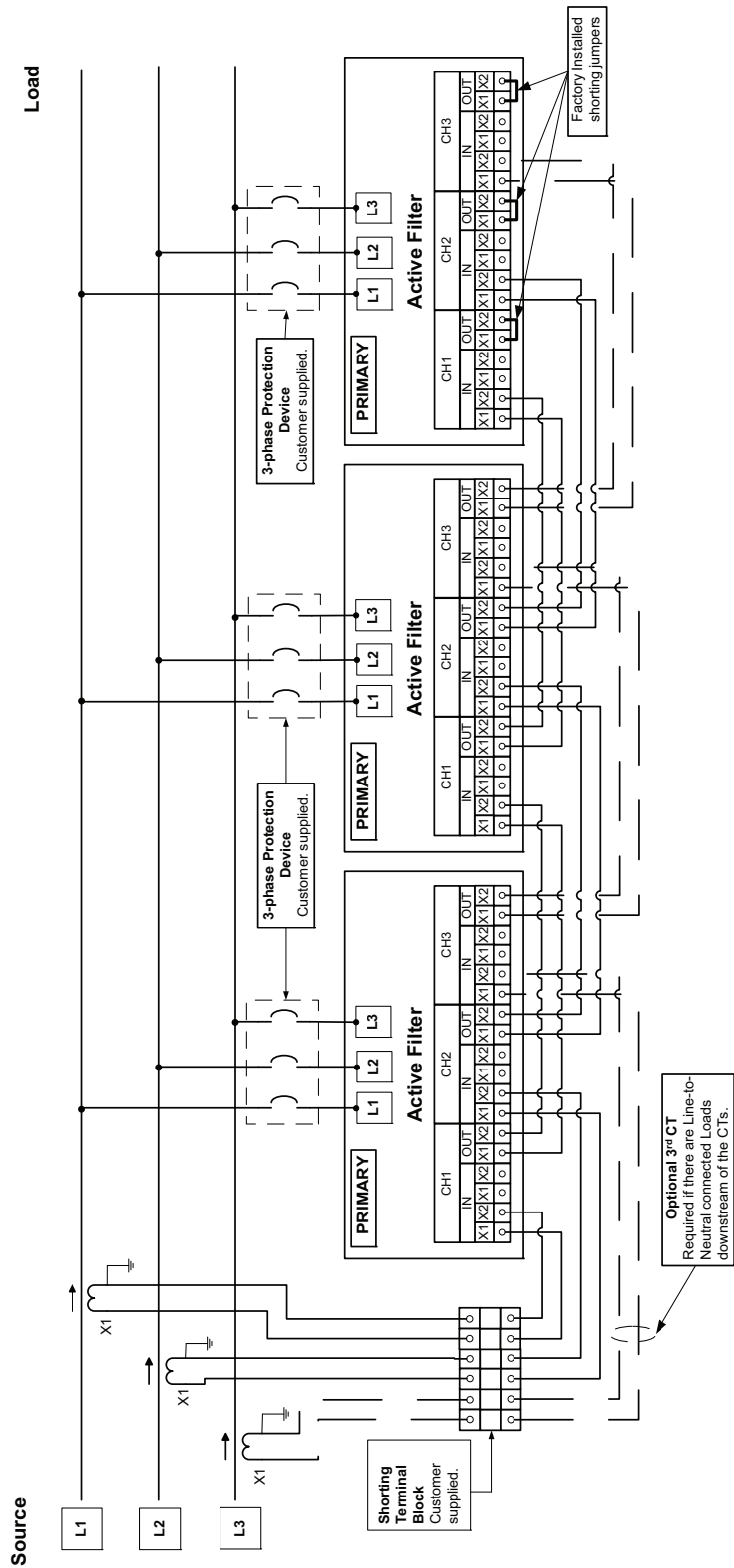

CT wiring for 2 Primaries and 1 Follower

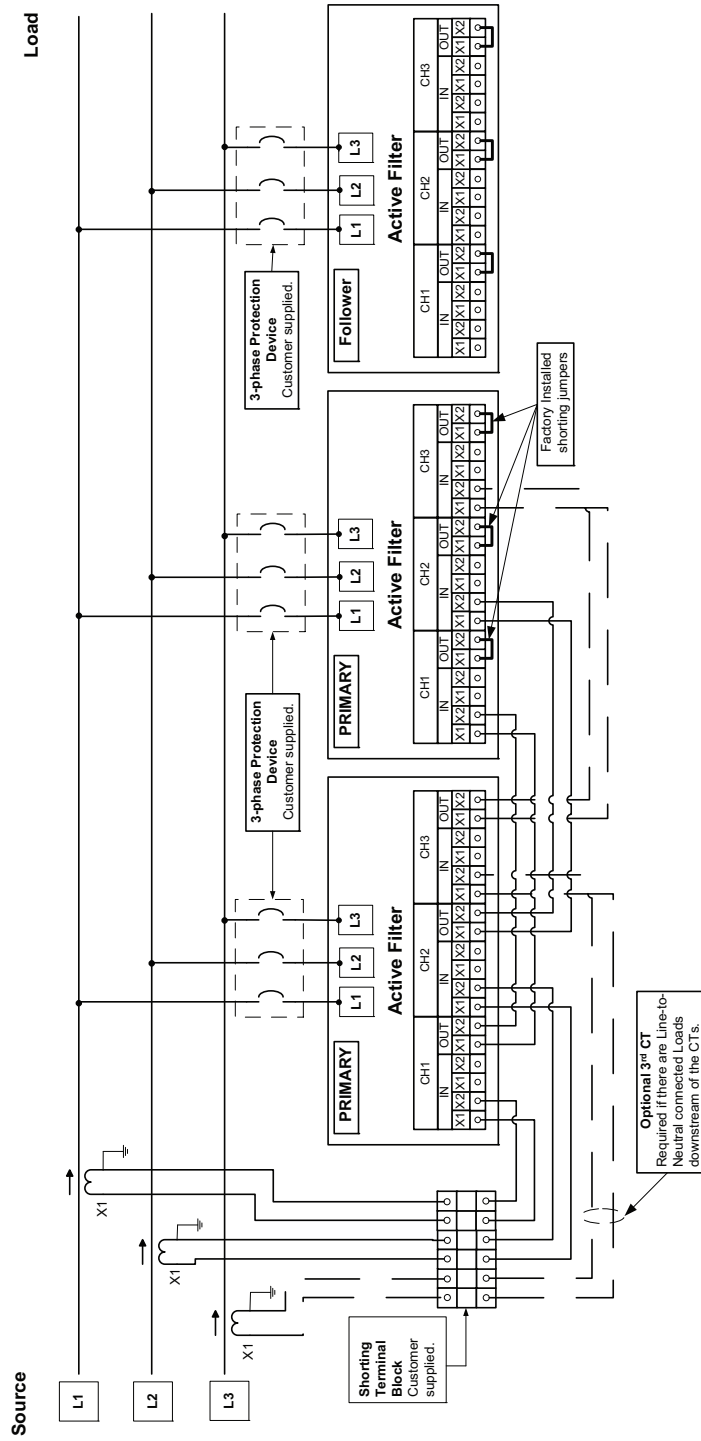

CT wiring for 2 Primaries and 3 Followers

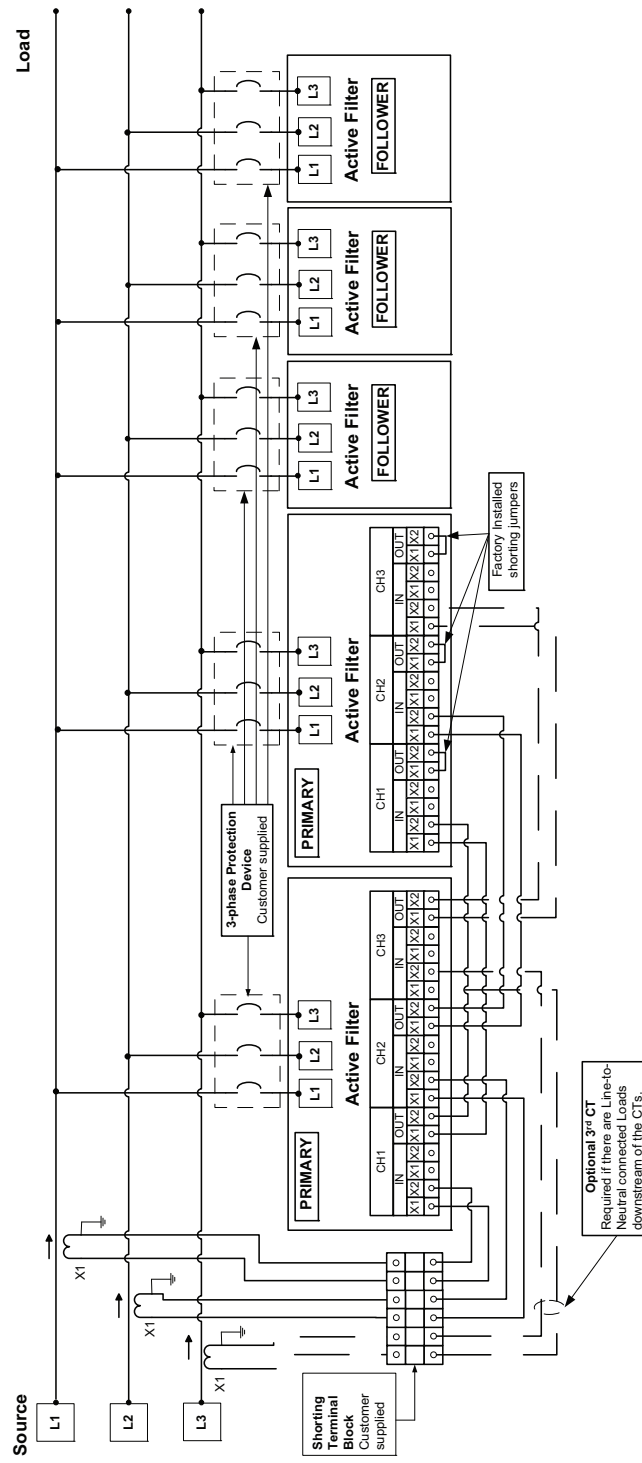

Parallel Communication

For parallel operation, the units communicate through the RJ-45 connectors labeled 1P and 2P on the Control Board. This is a unique communication protocol that is only to be used for parallel communication. The 2P jack has an RJ-45 termination plug installed at the factory.

NOTICE

EXCESSIVE NOISE IN THE COMMUNICATION CIRCUIT

When the unit is set to operate in parallel mode, the termination plug must be installed in any RJ-45 jacks that are not used for parallel communication wiring. See the wiring diagrams in this section.

Failure to follow this instruction can result in communication errors.

CAT5e cable with all 8 conductors terminated at the RJ-45 connections is required for parallel communication. It is recommended that shielded Cat5e cable be used. Ensure that the total cable length does not exceed 76 meters (250 feet). The CAT5e cable with RJ-45 plugs can be purchased as an option. Refer to the catalog for optional paralleling cable part numbers.

Control Board and CT Board Detail

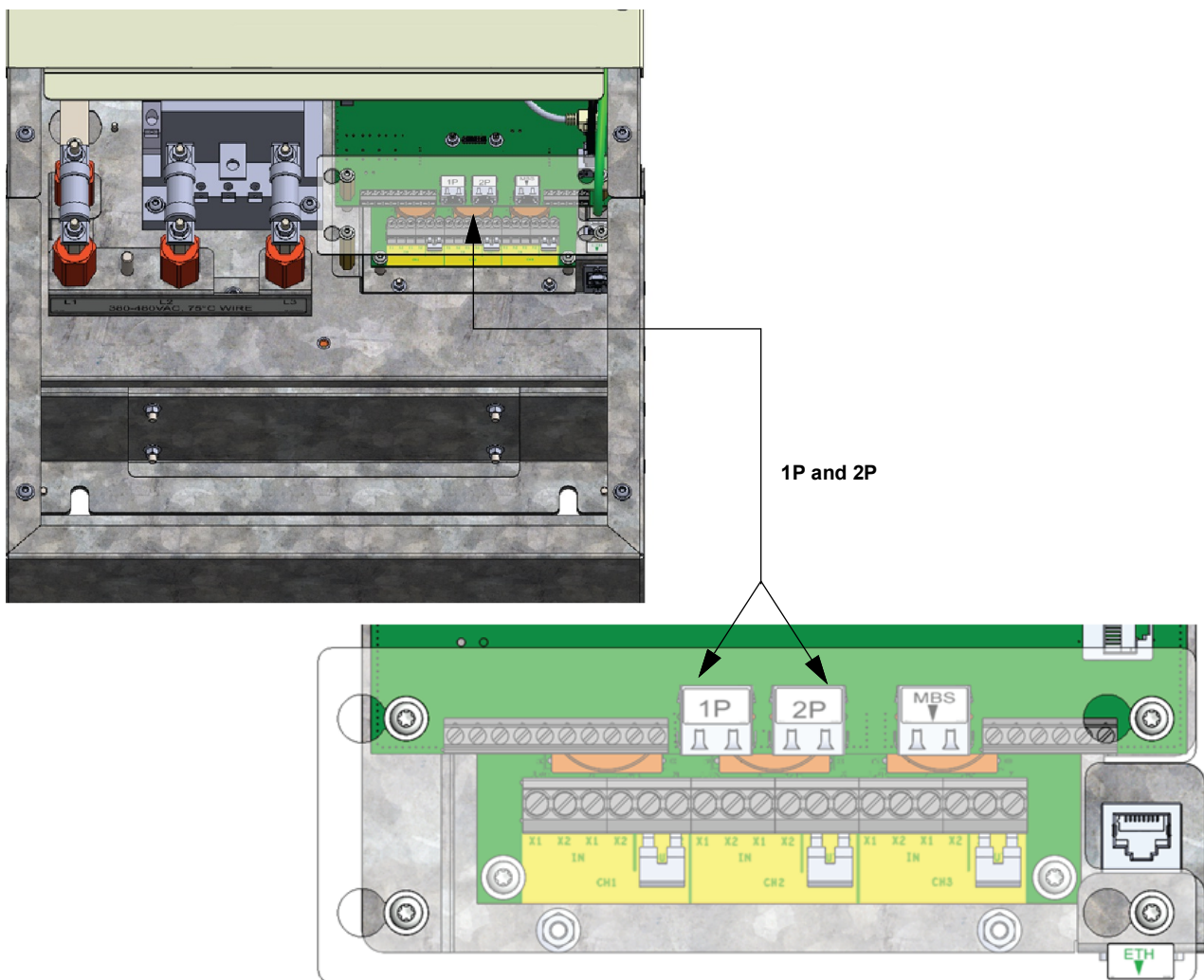

2 Unit Parallel Communication Wiring Diagram

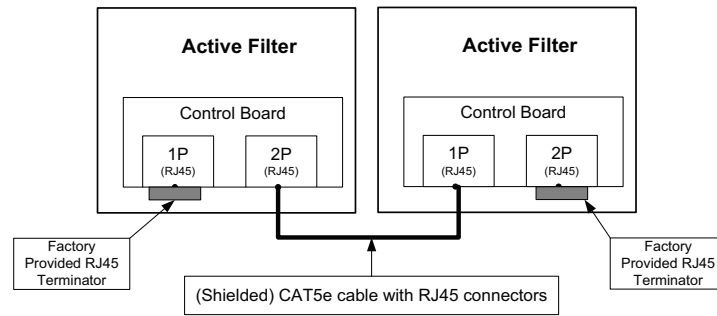

4 Unit Parallel Communication Wiring Diagram

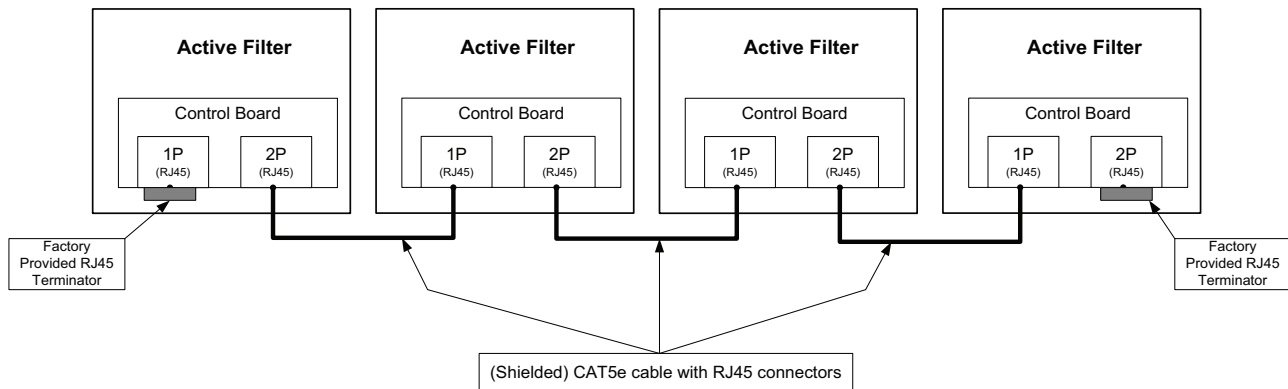

Control Wiring

Dry Contact Output

Four dry Contact outputs are available at J2 of the Control Board. See Control Board and CT Board Detail . One common and four switchable outputs are available labeled Q1 to Q4. The four outputs can be programmed to change states on different conditions by the HMI and be set to either normally open or normally closed. See the User Manual for setting the output contacts. Maximum voltage accepted is 250 V AC or 30 V DC with a 0.5 A maximum current per Dry Contact.

Digital Input Control

Four input controls are available at J2 of the Control Board. See Control Board and CT Board Detail . One Ground and four inputs labeled I1 to I4. The inputs are at 5 V DC and are grounded to activate. The control function can be programmed by the HMI. See the User Manual for setting the functionality of the input control.

Modbus TCP/IP

Modbus TCP/IP monitoring is available at the RJ-45 jack to the right of the Control Board labeled ETH. Refer to Control Board and CT Board Detail . Modbus addresses are provided in the User Manual.

Modbus Serial

A serial Modbus connection is available through an RJ-45 jack labeled MBS on the control board. Refer to Control Board and CT Board Detail . Modbus addresses are provided in the User Manual.

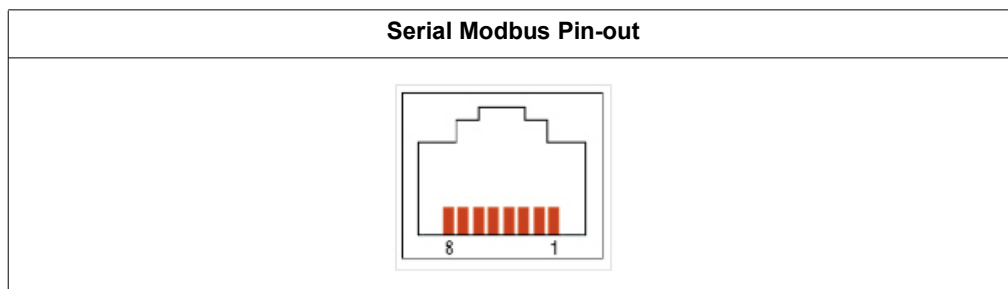

Pin	Signal Name	Direction	Meaning
1	Not connected	-	
2	Not connected	-	
3	Not connected	-	
4	D1	Input/Output	Transfer data (RS-485)
5	D0	Input/Output	Transfer data (RS-485)
6	Not connected	-	
7	Not connected	-	
8	SG	-	Signal ground

Control Board and CT Board Detail

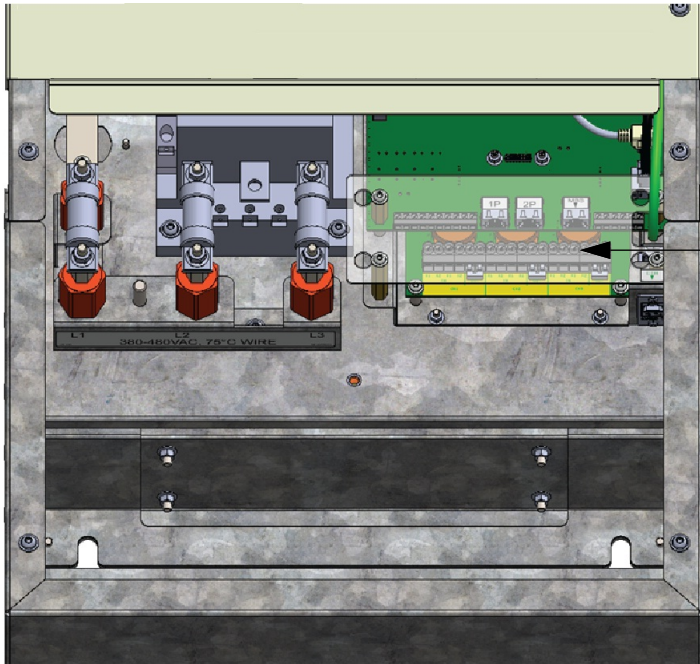

J2

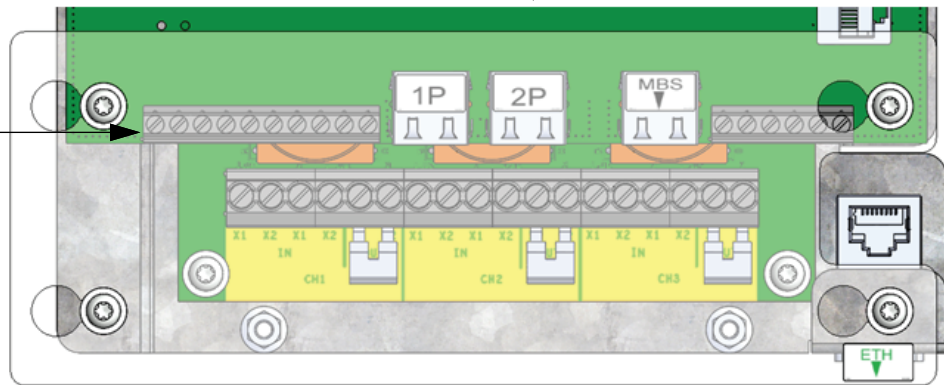

Control Board J2 Detail

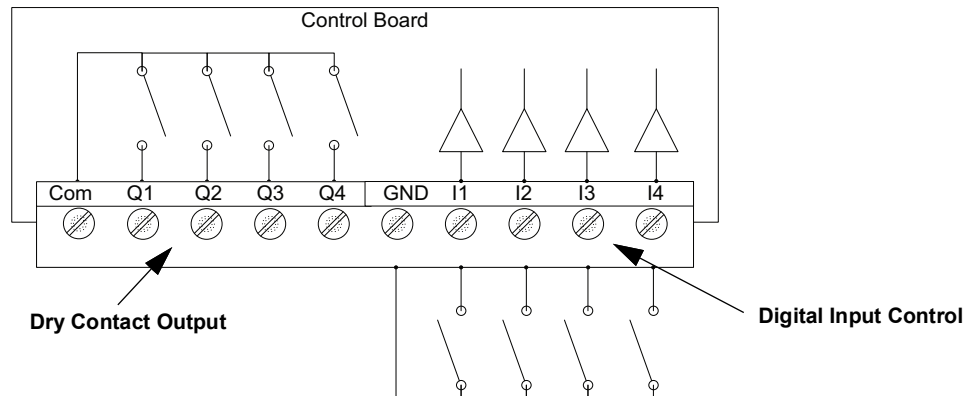

NOTE: The control board J2 accepts wire size between 0.5 and 2.5 mm² (20 and 14 AWG).

Requirement of wire for Dry Contact output			
Wire cross-sectional area (mm²)	Max. length (m)	Min. rated voltage (V AC)	Tightening Torque (Nm)
0.5	31	250	0.5...0.6
1	63		
1.5	94		
2	126		
2.5	157		

Requirement of wire for Digital Input Control			
Wire cross-sectional area (mm²)	Max. length (m)	Min. rated voltage (V AC)	Tightening Torque (Nm)
0.5...2.5	50	250	0.5...0.6

Chapter 4 Pre-commissioning

This chapter provides information for preparation of the active filter for commissioning. Before applying power, read and understand this information thoroughly.

Instruments required for commissioning

- Voltmeter or multimeter
- Clamp-on ammeter
- Megohmmeter

Pre-energizing procedure

DANGER

HAZARD OF ELECTRIC SHOCK, EXPLOSION, OR ARC FLASH

- Apply appropriate personal protective equipment (PPE) and follow safe electrical work practices. See NFPA 70E in the USA, CSA Z462, or applicable local standards.
- This equipment must be installed and serviced only by qualified electrical personnel.
- Do not exceed the device's ratings for maximum limits.
- Ground equipment using the ground connecting point provided before turning on any power supplying this device.
- Turn off all power supplying this device and the equipment in which it is installed before working on the device or equipment.
- After removing power, wait for 15 minutes to allow the capacitors to discharge prior to opening the doors or removing covers.
- Always use a properly rated voltage sensing device to confirm power is off.
- Replace all devices, doors, and covers before turning on power to this equipment.
- Carefully inspect the interior for tools left behind before closing and sealing the door.

Failure to follow these instructions will result in death or serious injury.

Installation Inspection

Inspect all connections for both power and control wiring. Ensure that the correct termination points have been made for each wire. Ensure that all connections are firmly tightened prior to start-up.

Pre-Commissioning Checklist

Prior to commissioning the active filter system, the following items must be completed:

- Electrical connections have been made in accordance with local codes.
- Main CTs are installed to measure the current of the system to be corrected.
- The secondary wiring of the main CTs have been connected to the CT board of the active filter.
- If it is a parallel active filter system, CT wiring and parallel communications wiring have been installed between the CT boards of each unit.
- All drives, harmonic generating loads, downstream of the main CTs must have the recommended minimum 3% line reactor or DC choke installed (required for optimum performance when harmonic mode is intended).
- There are no un-isolated capacitors, such as power factor correction capacitors downstream of the main CTs. (required when harmonic mode is intended to operate).
- To fully test the system integration, all loads supported by the active filter system should be available for operation. The total output current required for the system must be at least 10% of the unit's nameplate rating. For example, a 300 A unit will need a minimum of 30 A Total Output current.
- If backup generation is connected to the active filter, the system should also be tested with the generator supporting the connected loads.

The Field Service Engineer will need to know the following information to commission the active filter:

- Installation location of the main CTs in relationship to the active filter (load or grid, parallel systems must have the main CTs installed on the source side of the active filter system).
- The ratio of the main CT is installed.
- The phase on which each CT is installed.
- Intended mode of operation (Harmonic, Power Factor, Load Balancing).
- Make sure firmware version is the latest version as shown on se.com PCSP range page-Software and Firmware section <https://www.se.com/us/en/productrange/63426-powerlogic-accusine-pcs+/#software-and-firmware>.

Commissioning procedures

For commissioning procedures, refer to the user manual available on the Schneider Electric website.

Chapter 5 IT, HRG, and Corner Grounded Systems

This chapter provides information on using the active filter with Isolated Terra (IT), High Resistance Ground (HRG), and corner grounded systems.

DANGER

HAZARD OF ELECTRIC SHOCK, EXPLOSION, OR ARC FLASH

- Apply appropriate personal protective equipment (PPE) and follow safe electrical work practices. See NFPA 70E in the USA, CSA Z462, or applicable local standards.
- This equipment must be installed and serviced only by qualified electrical personnel.
- Do not exceed the device's ratings for maximum limits.
- Ground equipment using the ground connecting point provided before turning on any power supplying this device.
- Turn off all power supplying this device and the equipment in which it is installed before working on the device or equipment.
- After removing power, wait for 15 minutes to allow the capacitors to discharge prior to opening the doors or removing covers.
- Always use a properly rated voltage sensing device to confirm power is off.
- Replace all devices, doors, and covers before turning on power to this equipment.
- Carefully inspect the interior for tools left behind before closing and sealing the door.

Failure to follow these instructions will result in death or serious injury.

NOTICE

HAZARD OF EQUIPMENT DAMAGE

Open the IT/BP switches before operating the unit on an IT, HRG, or corner grounded system.

Failure to follow these instructions can result in equipment damage.

When connecting the active filter to an IT, HRG, or corner grounded system, open the IT/BP switches as follows:

1. Remove the large main cover of the unit.

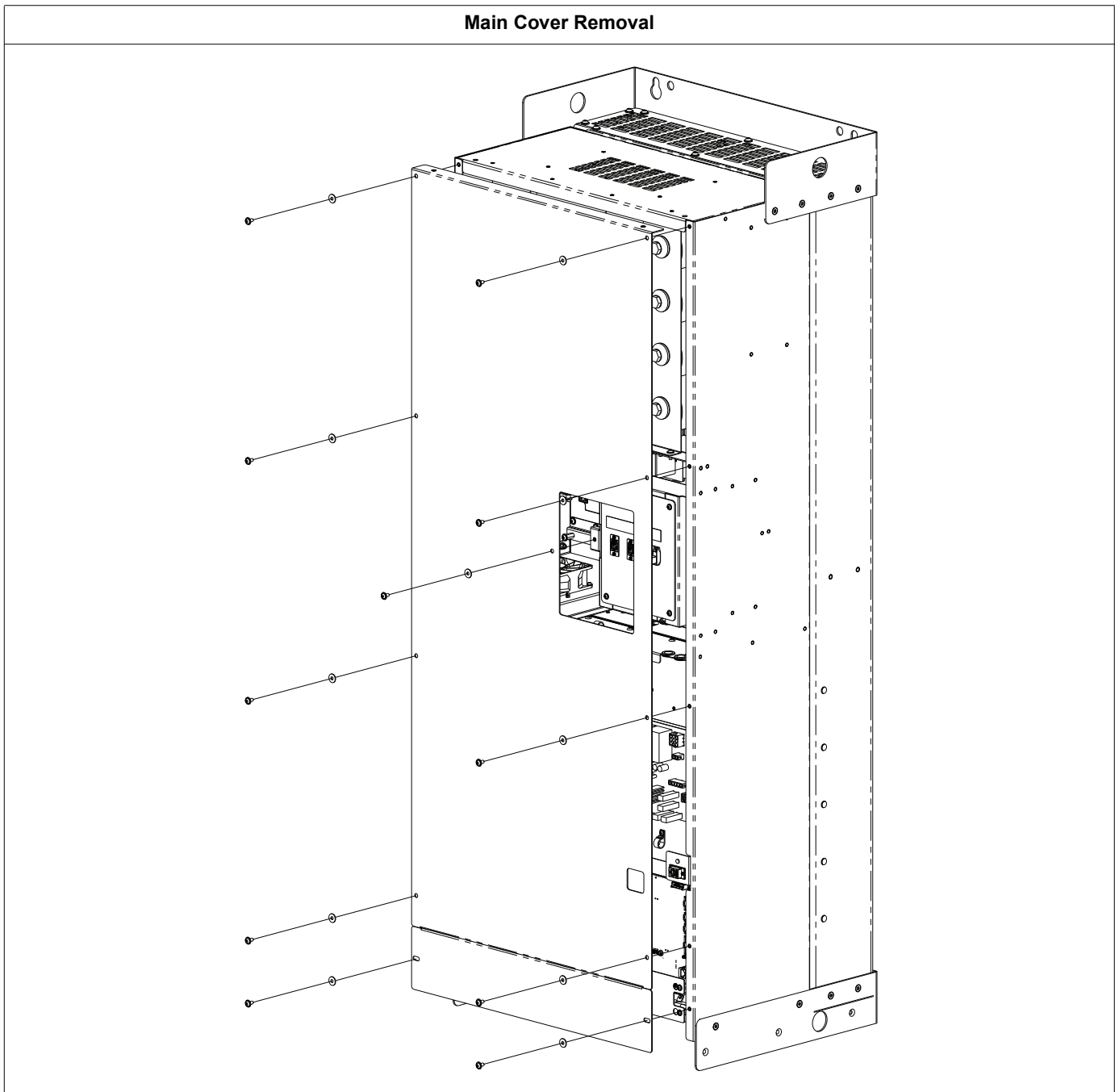

2. Locate the IT/BP switches.

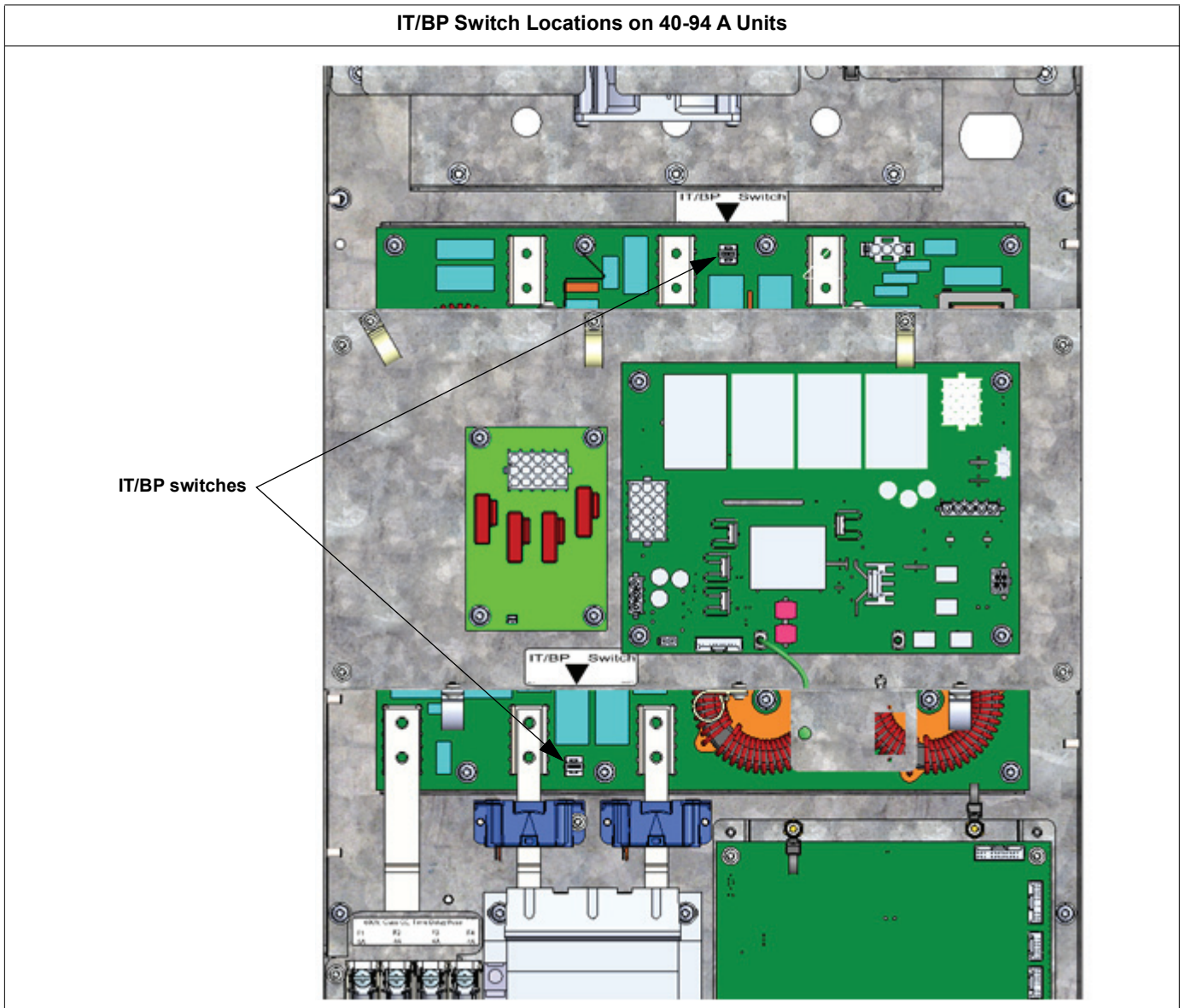

IT/BP Switch Locations on 133-235 A Units

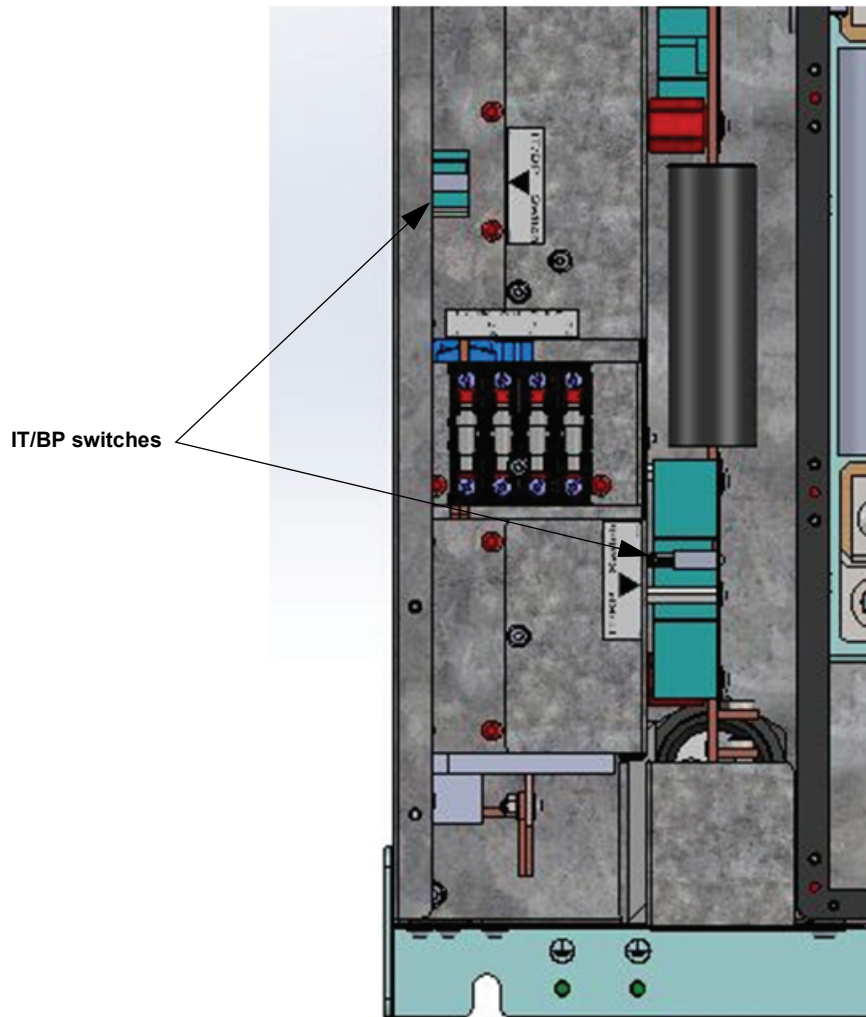

3. Pull the plunger out.

The switch is open when the plunger is completely out as shown here.

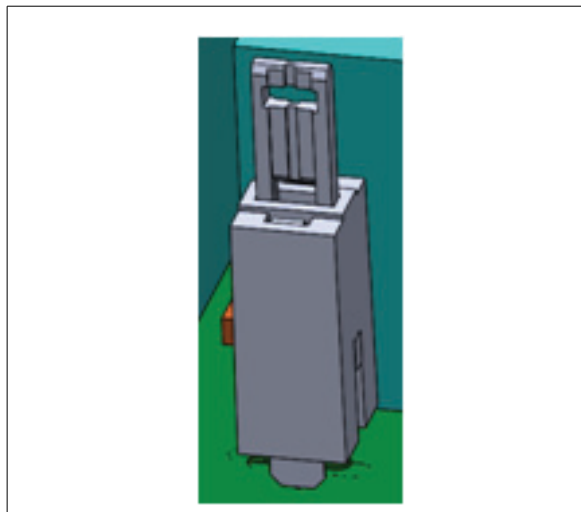



Schneider Electric

35 rue Joseph Monier
92500 Rueil Malmaison - France
Phone: +33 (0) 1 41 29 70 00
www.se.com

© 2024 Schneider Electric. All Rights Reserved.

NHA71461-02 11/2024



Schneider Electric

Stafford Park 5
Telford, TF3 3BL
United Kingdom

Importado en México por:

Schneider Electric México, S.A. de C.V.

Calz. Javier Rojo Gómez 1121-A

Col. Gpe. del Moral 09300 México, D.F.

Tel. 5804-5000

www.se.com.mx