

PowerLogic™

AccuSine PCS+ Active Harmonic Filter AccuSine PFV+ Electronic VAR Correction

IP00, IP20, UL Type 1, and UL Type Open

Installation Manual

PowerLogic offers power quality, uptime and efficiency.

NHA41798-03
11/2024

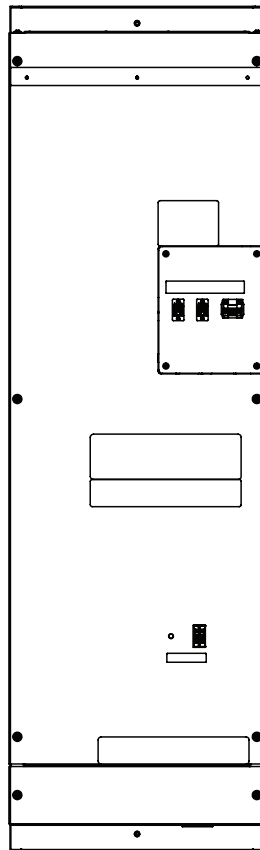
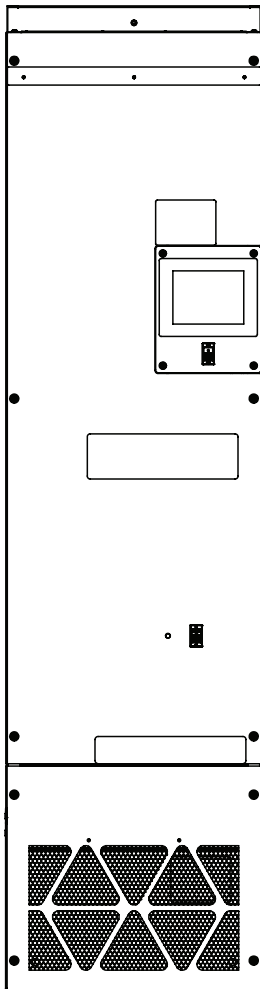

Legal Information

The information provided in this document contains general descriptions, technical characteristics and/or recommendations related to products/solutions.

This document is not intended as a substitute for a detailed study or operational and site-specific development or schematic plan. It is not to be used for determining suitability or reliability of the products/solutions for specific user applications. It is the duty of any such user to perform or have any professional expert of its choice (integrator, specifier or the like) perform the appropriate and comprehensive risk analysis, evaluation and testing of the products/solutions with respect to the relevant specific application or use thereof.

The Schneider Electric brand and any trademarks of Schneider Electric SE and its subsidiaries referred to in this document are the property of Schneider Electric SE or its subsidiaries. All other brands may be trademarks of their respective owner.

This document and its content are protected under applicable copyright laws and provided for informative use only. No part of this document may be reproduced or transmitted in any form or by any means (electronic, mechanical, photocopying, recording, or otherwise), for any purpose, without the prior written permission of Schneider Electric.

Schneider Electric does not grant any right or license for commercial use of the document or its content, except for a non-exclusive and personal license to consult it on an "as is" basis.

Schneider Electric reserves the right to make changes or updates with respect to or in the content of this document or the format thereof, at any time without notice.

To the extent permitted by applicable law, no responsibility or liability is assumed by Schneider Electric and its subsidiaries for any errors or omissions in the informational content of this document, as well as any non-intended use or misuse of the content thereof.

As part of a group of responsible, inclusive companies, we are updating our communications that contain non-inclusive terminology. Until we complete this process, however, our content may still contain standardized industry terms that may be deemed inappropriate by our customers.

Safety Information

Important information

Read these instructions carefully and look at the equipment to become familiar with the device before trying to install, operate, service or maintain it. The following special messages may appear throughout this bulletin or on the equipment to warn of potential hazards or to call attention to information that clarifies or simplifies a procedure.



The addition of either symbol to a “Danger” or “Warning” safety label indicates that an electrical hazard exists which will result in personal injury if the instructions are not followed.

This is the safety alert symbol. It is used to alert you to potential personal injury hazards. Obey all safety messages that follow this symbol to avoid possible injury or death.

DANGER

DANGER indicates a hazardous situation which, if not avoided, **will result in death** or serious injury.

WARNING

WARNING indicates a hazardous situation which, if not avoided, **could result in death** or serious injury.

CAUTION

CAUTION indicates a hazardous situation which, if not avoided, **could result in minor or moderate injury**.

NOTICE

NOTICE is used to address practices not related to physical injury.

Please note

Electrical equipment should be installed, operated, serviced and maintained only by qualified personnel. No responsibility is assumed by Schneider Electric for any consequences arising out of the use of this material.

A qualified person is one who has skills and knowledge related to the construction, installation, and operation of electrical equipment and has received safety training to recognize and avoid the hazards involved.

Safety precautions

Installation, wiring, testing and service must be performed in accordance with all local and national electrical codes.

DANGER

HAZARD OF ELECTRIC SHOCK, EXPLOSION, OR ARC FLASH

- Apply appropriate personal protective equipment (PPE) and follow safe electrical work practices. See NFPA 70E in the USA, CSA Z462, or applicable local standards.
- This equipment must be installed and serviced only by qualified electrical personnel.
- Do not exceed the device's ratings for maximum limits.
- Ground equipment using the ground connecting point provided before turning on any power supplying this device.
- Turn off all power supplying this device and the equipment in which it is installed before working on the device or equipment.
- After removing power, wait for 15 minutes to allow the capacitors to discharge prior to opening the doors or removing covers.
- Always use a properly rated voltage sensing device to confirm power is off.
- Replace all devices, doors, and covers before turning on power to this equipment.
- Carefully inspect the interior for tools left behind before closing and sealing the door.

Failure to follow these instructions will result in death or serious injury.

Cybersecurity

Introduction

Cybersecurity is a branch of network administration that addresses attacks on or by PCs and through PC networks that can result in accidental or intentional disruptions. The objective of cybersecurity is to help provide increased levels of protection for information and physical assets from theft, corruption, misuse, or accidents while maintaining access for their intended users.

No single cybersecurity approach is adequate. Schneider Electric recommends a defense-in-depth approach. Conceived by the National Security Agency (NSA), this approach layers the network with security features, appliances, and processes. The basic components of this approach are:

- Risk assessment
- Security plan built on the results of the risk assessment
- Multi-phase training campaign
- Physical separation of the industrial networks from enterprise networks using a demilitarized zone (DMZ) and the use of firewalls and routing to establish other security zones
- System access control
- Device hardening
- Network monitoring and maintenance

This section defines elements that help you configure a system that is less susceptible to cyber attacks. For detailed information on the defense-in-depth approach, refer to the Recommended Cybersecurity Best Practices on the Schneider Electric website.

Schneider Electric's Approach on Cybersecurity

Schneider Electric adheres to industries best practice in the development and implementation of control systems. This includes a defense-in-depth approach to secure an industrial control system. This approach places the controllers behind one or more firewalls to restrict access to authorized personnel and protocols only.

WARNING

UNAUTHENTICATED ACCESS AND SUBSEQUENT UNAUTHORIZED OPERATION

- Evaluate whether your equipment or complete environment are connected to your critical infrastructure. If so, take appropriate steps in terms of prevention, based on defense-in-depth, before connecting the automation system to any network.
- Limit the number of devices connected to a network inside your company.
- Isolate your industrial network from other networks inside your company.
- Protect any network against unintended access by using firewalls, VPN, or other, proven security measures.
- Monitor activities within your systems.
- Prevent subject devices from direct access or direct link by unauthorized parties or unauthenticated actions.
- Prepare a recovery plan including backup of your system and process information.

Failure to follow these instructions can result in death, serious injury, or equipment damage.

Cyber Threats

Cyber threats are deliberate actions or accidents that can disrupt the normal operations of PCs and PC networks. These actions can be initiated from within the physical facility or from an external location. Security challenges for the control environment include:

- Diverse physical and logical boundaries.
- Multiple sites and large geographic spans.
- Adverse effects of security implementation on process availability.
- Increased exposure to worms and viruses migrating from business systems to control systems as business-control communications become more open.
- Increased exposure to malicious software from USB devices, vendor and service technician laptops, and the enterprise network.
- Direct impact of control systems on physical and mechanical systems.

Sources of Cyber Attacks

Implement a cybersecurity plan that accounts for various potential sources of cyberattacks and accidents, including:

Source	Description
Internal	<ul style="list-style-type: none"> – Inappropriate employee or contractor behaviour – Disgruntled employee or contractor
External opportunistic (non-directed)	<ul style="list-style-type: none"> – Script kiddies⁽¹⁾ – Recreational hackers – Virus writers
External deliberate (directed)	<ul style="list-style-type: none"> – Criminal groups – Activists – Terrorists – Agencies of foreign states
Accidental	
⁽¹⁾ Slang term for hackers who use malicious scripts written by others without necessarily possessing a comprehensive understanding of how the script works or its potential impact on a system	

A deliberate cyber attack on a control system may be launched to achieve a number of malicious results, including:

- Disrupt the production process by blocking or delaying the flow of information.
- Damage, disable, or shut down equipment to negatively impact production or the environment.
- Modify or disable safety systems to cause intentional harm.

How Attackers Gain Access

A cyber attacker bypasses the perimeter defenses to gain access to the control system network. Common points of access include:

- Dial-up access to remote terminal unit (RTU) devices.
- Supplier access points (such as technical support access points).
- IT-controlled network products.
- Corporate virtual private network (VPN).
- Database links.
- Poorly configured firewalls.
- Peer utilities.

Sources of Cyber Attacks

To submit a cybersecurity question, report security issues, or to get the latest news from Schneider Electric, visit our [Schneider Electric Country website](#).

	Safety Information	4
	Safety precautions	5
	Cybersecurity	6
	Introduction	6
	Schneider Electric's Approach on Cybersecurity	6
	Cyber Threats	7
	Sources of Cyber Attacks	7
	How Attackers Gain Access	8
	Sources of Cyber Attacks	8
Chapter 1	Introduction	11
	PowerLogic Master Range	11
	Active Harmonic Filter	11
	Electronic VAR Control	11
Chapter 2	Receiving, handling, and storing	13
	Receiving	13
	Inspection	13
	Handling	13
	Storing	14
Chapter 3	Installation	15
	Foundation preparation	16
	Installation	16
	Environmental Requirements	16
	Physical Installation	17
	Standard Units Physical Description	17
	Dimensional Drawings	18
	IP00 60 A and 120 A Drawings	19
	IP20 60 A and 120 A Drawings	24
	200 A and 300 A Drawings	28
	Electrical Connection	36
	Line Voltage	36
	Over-current Protection Device Selection	36
	Residual Current Device	36
	Power Cable Routing	37
	Power and Ground Cable Selection and Connections	38
	60 A Models	39
	120 A Models	40
	200 A and 300 A Models	42
	Current Transformers (CTs)	43
	General CT Information	43
	Minimum CT Requirements	44
	CT to CT Board Connection	45
	Maximum Wire Length	47
	Parallel System	49
	CT Installation Parallel Units	49
	Parallel Communication	54
	Control Wiring	56
	Dry Contact output	56
	Digital Input Control	56
	Modbus TCP/IP	56
	Modbus Serial	56

Chapter 4	UL Type 1/IP20 Conversion Kit Assembly (Optional)	59
	Prepare the active filter chassis for UL Type 1/IP20 Conversion Kit	60
	Connect the HMI ground wire to the chassis	62
	Attach the HMI to the HMI mounting plate	63
	Connect the USB jack to the HMI mounting plate	64
	HMI Power wiring	64
	Installation of the HMI assembly in the Chassis	65
	Attaching the Wall Mount Kit to the Chassis for 60 A and 120 A Units	66
	Attaching the Wall Mount Kit to the Chassis for 200 A and 300 A Units	67
Chapter 5	Pre-commissioning	69
	Instruments required for commissioning	69
	Pre-energizing procedure	69
	Installation Inspection	69
	Pre-Commissioning Checklist	70
	Commissioning procedures	70
Chapter 6	IT, HRG, and Corner Grounded Systems	71
Chapter 7	IP00 chassis in a customer supplied enclosure	75
	HMI Connections	79
	24 volt power	79
	Ethernet	79
	Communication	79
	Enclosure mount USB	79
	Dimensional Drawings	80

Chapter 1 Introduction

The product can be provided in either of two types, an Active Harmonic Filter (AHF) or an Electronic VAR Control (EVC). Both types are to be installed as described in this manual. These products are both referred to as an active filter in this manual.

PowerLogic Master Range

PowerLogic smooths the power supply, helps to protect the network, the installation and the operator by improving the power factor and hence the quality of the power. It also allows for remote control of equipment and the monitoring of its performance and condition in real time.

Active Harmonic Filter

Active Harmonic Filters (AHF) are static power electronic products that employ digital logic and IGBT semiconductors to synthesize a current waveform that is injected into the electrical network to cancel harmonic currents caused by nonlinear loads. AHF employ current transformers to measure the load current to determine the content of harmonic current present. By injecting the synthesized current, network harmonic currents are greatly mitigated, thus reducing the heating effects of harmonic current and reducing voltage distortion.

AHF also have the ability to correct for poor displacement power factor (DPF) and for mains current balancing. DPF correction can be provided for either leading (capacitive) or lagging (inductive) loads that cause poor DPF. Mains current balancing is achieved by measuring the negative sequence current present and injecting the inverse negative sequence current to balance the current for the upstream network.

Multiple enclosure styles are available. IP00 open chassis designs can be installed in other types of enclosures such as motor control centers (MCC).

Electronic VAR Control

Electronic VAR control are static power electronic products that employ digital logic and IGBT semiconductors to synthesize a current waveform that is injected into the electrical network to cancel load induced poor displacement power factor, phase current unbalance, and flicker. DPF correction can be provided for either leading (capacitive) or lagging (inductive) loads that cause poor DPF. Mains current balancing is achieved by measuring the negative sequence current present and injecting the inverse negative sequence currents to balance the current for the network. Flicker control is provided by rapid detection and injection of reactive current (VARs) to help prevent the reactive current from over loading the network that causes rapid voltage deviations identified as flicker.

EVC also have the ability to monitor the network voltage on which they are connected and determine the proper amount of VARs to either raise the network voltage or lower it. EVC will inject leading VARs to raise the voltage and lagging VARs to lower the voltage. Entry of appropriate parameters will keep the network within its stated voltage tolerance level.

Multiple enclosure styles are available. IP00 open chassis designs can be installed in other types of enclosures such as motor control centers (MCC).

Chapter 2 Receiving, handling, and storing

Receiving

Inspect the active filter for any damage as soon as it is received. Transfer of the equipment to a carrier at any manufacturing plant or other shipping point constitutes delivery to the purchaser. Title and all risk of loss or damage in transit shall pass to the purchaser at that time, regardless of freight payment.

Inspection

- Check that all packages and/or crates have been delivered and that the equipment has not been damaged in transit.
- On the outside packaging and inside the unit, Drop N Tell monitoring devices are installed. If these have been activated, inform the carrier immediately.



- In the event of damaged or missing items, contact the carrier immediately. Check with them for time limits for filing claims and any documentation required such as a Bill of Lading number, etc.
- Goods, whether sent freight pre-paid or not, are shipped at the consignee's risk.
- Damaged or missing items are the responsibility of the carrier and must be reported.
- Check that the information shown on the equipment nameplates corresponds with the order specifications.
- The packaging material should be replaced to help protect the unit until installation has begun.

Handling

⚠ WARNING
<p>HAZARD OF PERSONAL INJURY</p> <ul style="list-style-type: none"> • Use proper lifting equipment such as an overhead crane to handle the active filter. • Do not lay the equipment on its front. <p>Failure to follow these instructions can result in death, serious injury, or equipment damage.</p>

Ensure that the proper equipment such as an overhead crane is available at the installation site to handle the active filter. This equipment will help avoid injury to personnel and damage to the active filter.

Verify the lifting capacity of the equipment being used to handle the active filter in accordance with the shipping weight of each shipping section.

Storing

If the active filter is not to be installed when unpacked, it should be stored indoors in a clean, dry place. The storage temperature must be between -20 °C (-4 °F) and 60 °C (140 °F) with a maximum relative humidity of 85%, non-condensing, and a maximum dewpoint of 37 °C (98.6 °F). It is preferable to store the unit in its original shipping container to help protect the unit from potential damage.

Chapter 3 Installation

This chapter provides the information required to properly install the active filter and associated equipment for proper operation and performance. Frequently, commissioning difficulties are the result of incorrect wiring. Every precaution must be taken to make sure that the wiring is done as instructed. Read and understand all instructions in this manual prior to installation.

Correct installation of the active filter is essential for proper operation of all components. Study the associated instruction books and all drawings carefully.

The location chosen for installation should provide working clearances complying with the appropriate section of the National Electrical Code® (NEC®), the Canadian Electrical Code (CEC), or applicable local standards.

DANGER

HAZARD OF ELECTRIC SHOCK, EXPLOSION, OR ARC FLASH

- Apply appropriate personal protective equipment (PPE) and follow safe electrical work practices. See NFPA 70E in the USA, CSA Z462, or applicable local standards.
- This equipment must be installed and serviced only by qualified electrical personnel.
- Do not exceed the device's ratings for maximum limits.
- Ground equipment using the ground connecting point provided before turning on any power supplying this device.
- Turn off all power supplying this device and the equipment in which it is installed before working on the device or equipment.
- Do not stand on any part of the active filter.
- After removing power, wait for 15 minutes to allow the capacitors to discharge prior to opening the doors or removing covers.
- Always use a properly rated voltage sensing device to confirm power is off.
- Replace all devices, doors, and covers before turning on power to this equipment.
- Carefully inspect the interior for tools left behind before closing and sealing the door.

Failure to follow these instructions will result in death or serious injury.

The following is a summary of the steps for installation covered in this chapter:

1. Make sure that the line voltage is compatible with the voltage rating of the active filter.
2. Make sure that the foundation is prepared for the active filter.
3. Make sure that environmental requirements are satisfied.
4. Refer to the dimensional drawings for the active filter to be installed.
5. Mount the unit in the desired location.
6. Make the electrical connections.
7. Make the CT to CT board connection.

8. Set up parallel communication if applicable.
9. When installing on Isolated Terra (IT), High Resistance Ground (HRG), or corner grounded systems, make sure that the IT/BP switches are open. Refer to IT, HRG, and Corner Grounded Systems.
10. Make the control wiring connections, but do not energize the active filter yet.

NOTE: Commissioning and energizing the active filter requires specialized knowledge. Pre-commissioning procedures are covered in Pre-commissioning. Commissioning procedures are covered in the User Manual. Commission the active filter and energize it only if you are qualified to do so.

Foundation preparation

The mounting location must be able to support the weight of the unit without sagging. Weight specifications are provided in Open/IP00 and UL Type 1/IP20 Enclosures Physical Specifications.

Installation

For optimum performance in harmonic mitigation mode, adhere to the following recommendations:

- All harmonic generating loads must have a minimum 3% line reactor or 3% DC choke installed.
- SCR based rectifiers are required to have a minimum 3% line reactor.
- No capacitors downstream of the Main CTs.

NOTICE

RISK OF EQUIPMENT DAMAGE

Adhere to DC choke, SCR based rectifier, and capacitor placement requirements.

Failure to follow this instruction can result in equipment damage.

If these recommendations are not followed, the target harmonic level may not be met and equipment damage can occur.

Environmental Requirements

Active filters are designed for indoor use only. They require unrestricted exchange of environmental air to the inside of the enclosure for proper cooling. Make sure that the environment meets Pollution Degree 2, i.e., does not contain conductive particles, significant amounts of dust, or corrosive or otherwise harmful gases. Normally only non-conductive pollution occurs. Temporary conductivity caused by condensation is to be expected.

NOTICE

RISK OF EQUIPMENT DAMAGE

Ensure that the installation location satisfies environmental requirements.

Failure to follow this instruction can result in equipment damage.

If environmental requirements are not adhered to, malfunction and possible destruction of the active filter can occur.

The active filter generates significant heat during operation. Consult the product specifications in Electrical Specifications 60, 120, 200 and 300 A Units for the watt losses for each active filter model. Make sure that the room where the active filter is mounted has adequate ventilation. For 60 A, 120 A, and 200 A unit ratings, the intake air temperature must be between 0 °C (32 °F) and 45 °C (113 °F) and for 300 A unit rating, the intake air temperature must be between 0 °C (32 °F) and 40 °C (104 °F). Maintain a maximum relative humidity of 95%, non-condensing, and a maximum dewpoint of 37 °C (98.6 °F) for all unit ratings.

The operating temperatures are maximum and minimum levels the unit is designed to operate within. Operating above or below these levels will result in the unit either shutting down or reduced performance. The upper or lower limit should not be used as ideal room temperature levels. System reliability and product life expectancy will improve if temperature levels are maintained between 20 °C (68 °F) and 30 °C (86 °F).

Physical Installation

The active filter is provided standard as a UL open/IP00 chassis unit. The unit can be converted to a UL Type 1/IP20 with an optional conversion kit. The following table describes each type.

Enclosure Type	Open/IP00	UL Type 1/IP20
Enclosure provided	No	Yes
Standard Compliance: UL Type	Open	Type 1
Standard Compliance: IEC 60529	IP00	IP20
Unrestricted air exchange, protection against contact with enclosed parts, protection against limited amount of falling dirt, intake of dust, and harmful particles	No	Yes
Complete protection against touch	No	Yes
Protection against dripping water and external condensation of non-corrosive liquids	No	No
EMC/RFI certification	Yes	Yes

NOTE: This list indicates minimum requirements. Complete descriptions of the requirements are provided in the standards referenced in this list.

Standard Units Physical Description

Open/IP00 and UL Type 1/IP20 Enclosures Physical Specifications

Active filter rating	Cable entry	Voltage range (Volts)	Heat load (kW) at applied voltage			Operating temperature	Weight Kg (lbs)		Exterior dimensions H x W x D mm (inches)	
			208 V	400 V	480 V		Open and IP00	UL Type 1 and IP20	Open and IP00	UL Type 1 and IP20
60 A	Bottom	208...240	1	-	-	0...45 °C (32...113 °F)	90 (198)	100 (220)	1300 x 426 x 348 (51.2 x 16.8 x 13.7)	1534 x 426 x 348 (60.4 x 16.8 x 13.7)
		380...480	-	0.95	1.1					
120 A	Bottom	208...240	1.9	-	-	0...45 °C (32...113 °F)	113 (249)	122 (268)	1400 x 426 x 384 (55.1 x 16.8 x 15.1)	1634 x 426 x 384 (64.3 x 16.8 x 15.1)
		380...480	-	2.0	2.2					
200 A	Bottom	208...240	3.7	-	-	0...45 °C (32...113 °F)	175 (385)	184 (409)	1323 x 581 x 438 (52.1 x 22.9 x 17.2)	1598 x 581 x 438 (62.9 x 22.9 x 17.2)
		380...480	-	3.9	4.3					
300 A	Bottom	208...240	5.6	-	-	0...40 °C (32...104 °F)	220 (484)	229 (504)	1560 x 581 x 438 (61.4 x 22.9 x 17.2)	1835 x 581 x 438 (72.2 x 22.9 x 17.2)
		380...480	-	5.9	6.6					

NOTE:

- Wall mounted units (UL Type 1/IP20) require 305 mm (12 in) of top clearance.
- Weight information is approximate and subject to change without notice.
- Lifting lugs are provided for hoisting.

Dimensional Drawings

Refer to the drawings on the following pages for dimensions of the active filter to be installed.

IP00 60 A and 120 A Drawings

Open/IP00 60 A Enclosure Dimensional Drawing

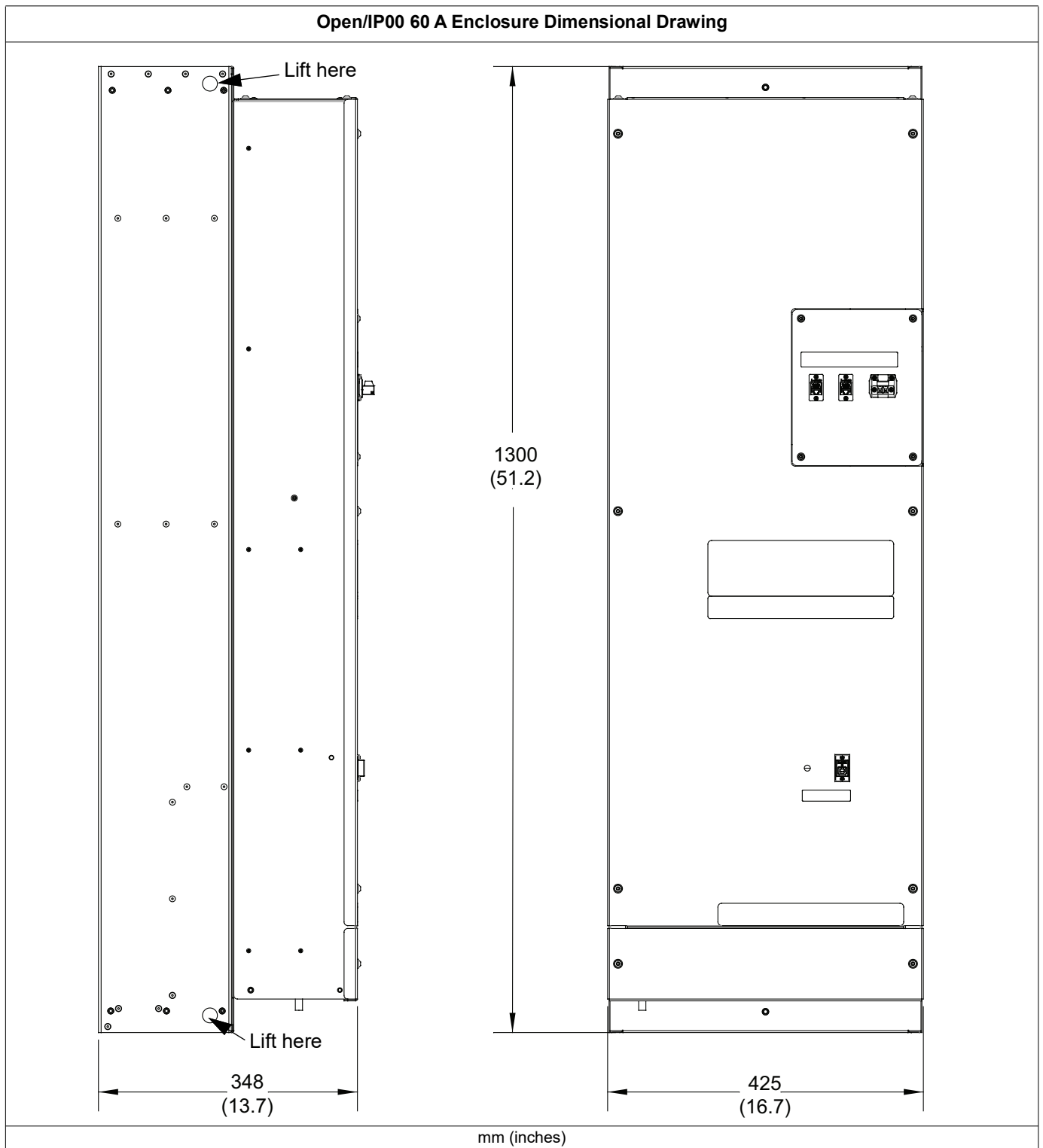

Open/IP00 60 A Enclosure Top and Bottom Dimensional Drawing

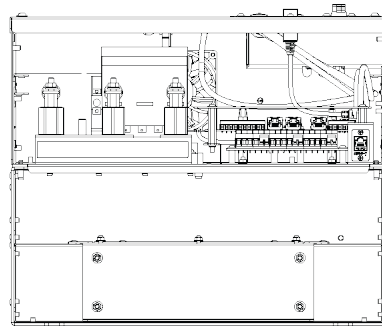
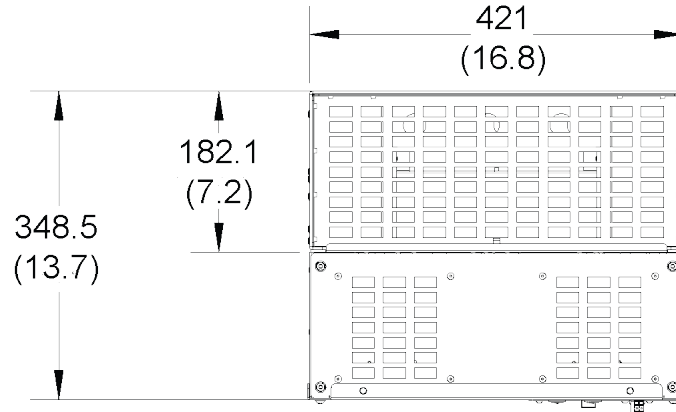

mm (inches)

IP00 120 A Enclosure Dimensional Drawing

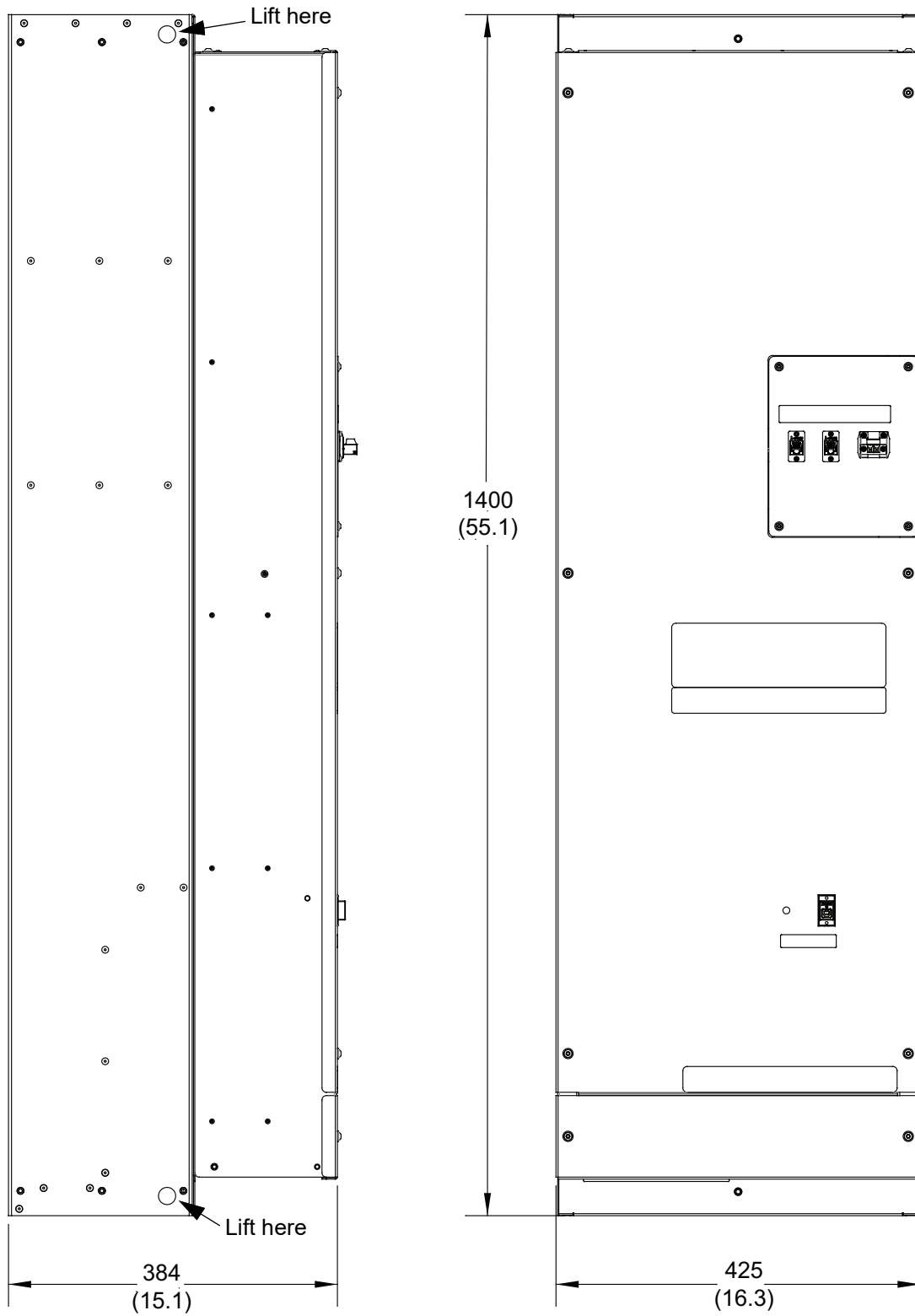

mm (inches)

IP00 120 A Enclosure Top and Bottom Dimensional Drawing

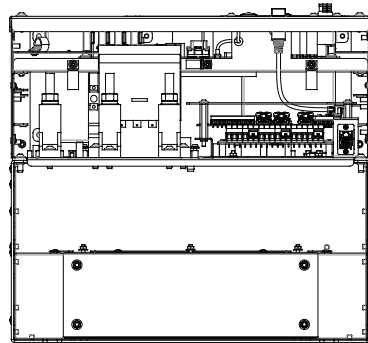
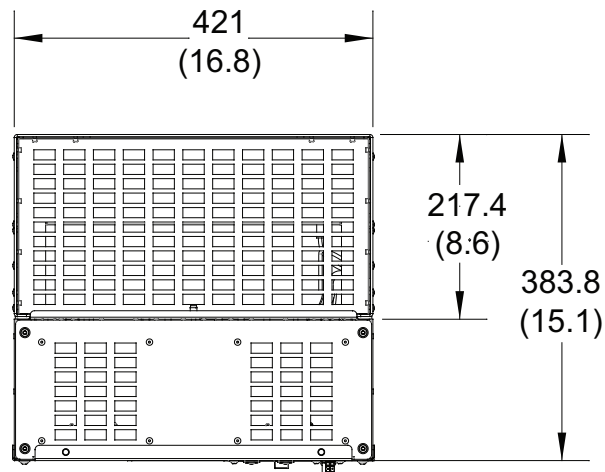

mm (inches)

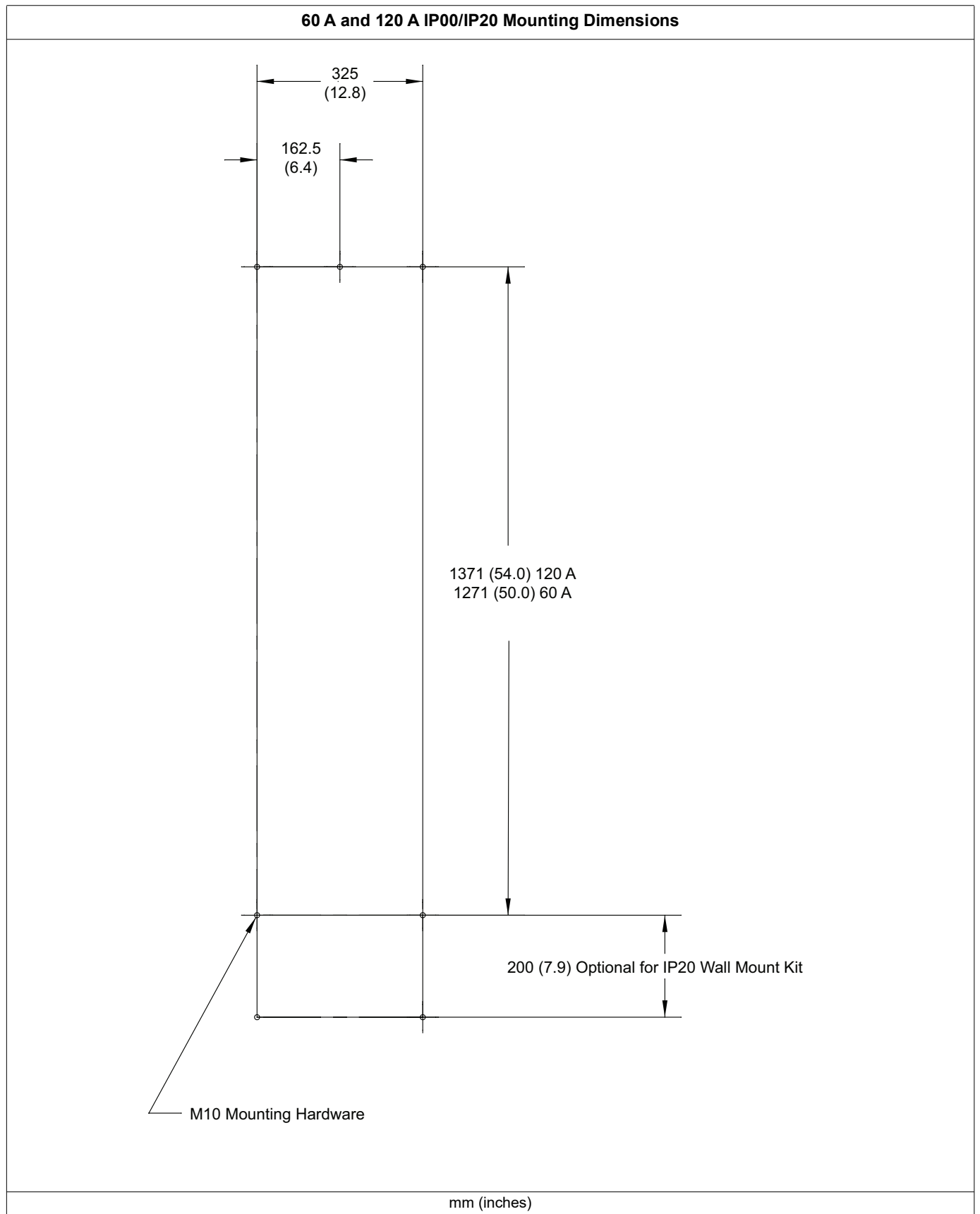

IP20 60 A and 120 A Drawings

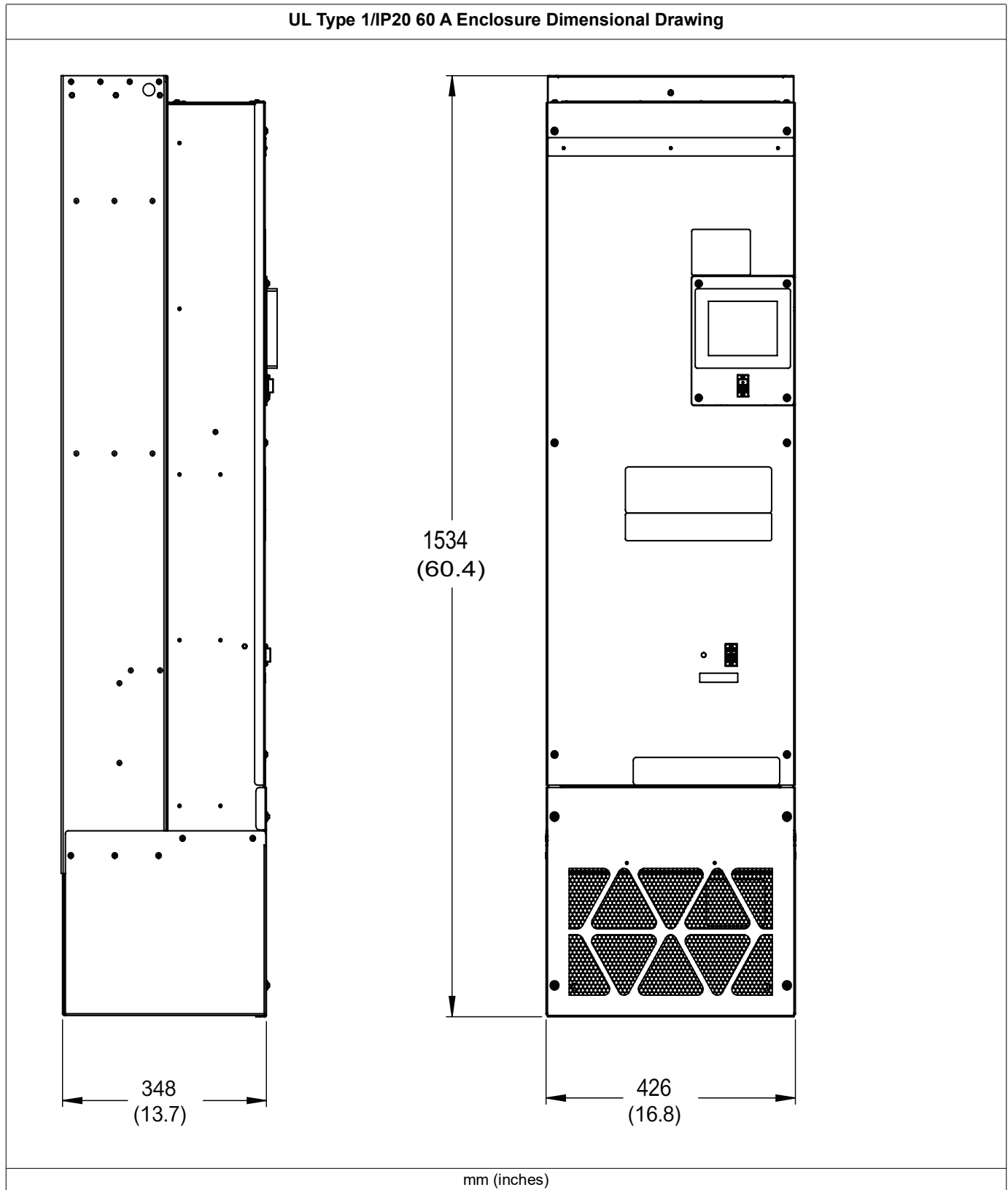

UL Type 1/IP20 60 A Enclosure Top and Bottom Dimensional Drawing

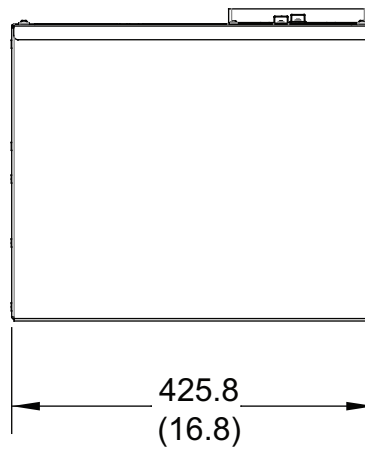
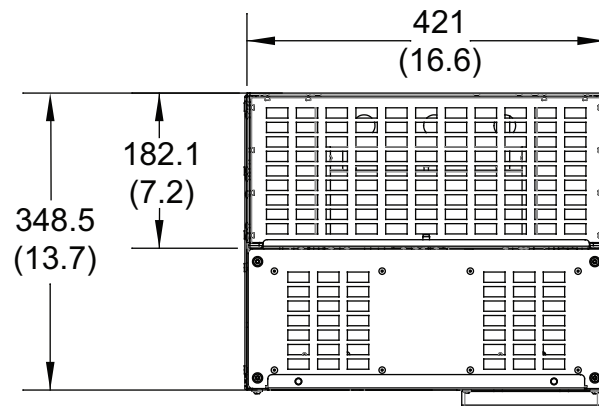

mm (inches)

IP20 120 A Enclosure Dimensional Drawing

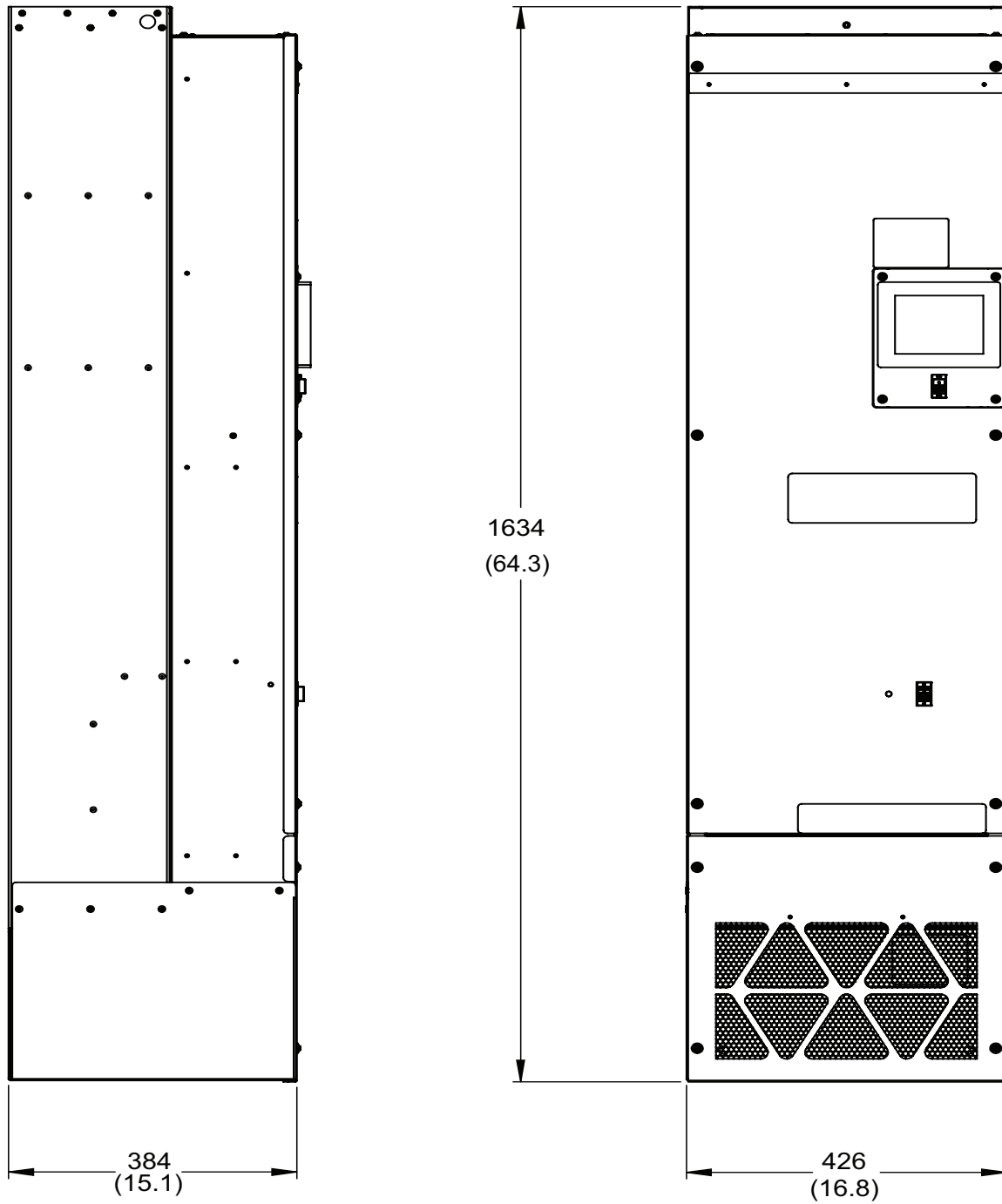

mm (inches)

IP20 120 A Enclosure Top and Bottom Dimensional Drawing

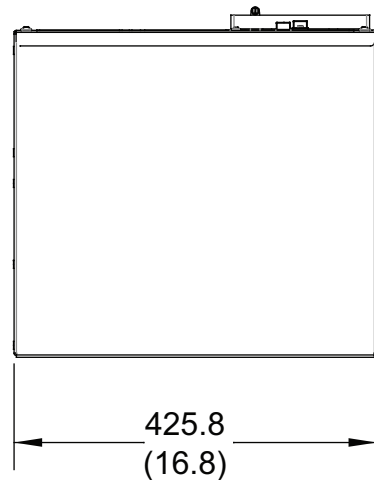
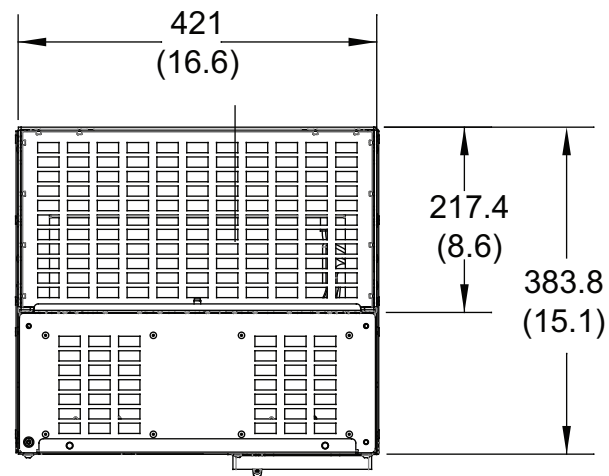

mm (inches)

200 A and 300 A Drawings

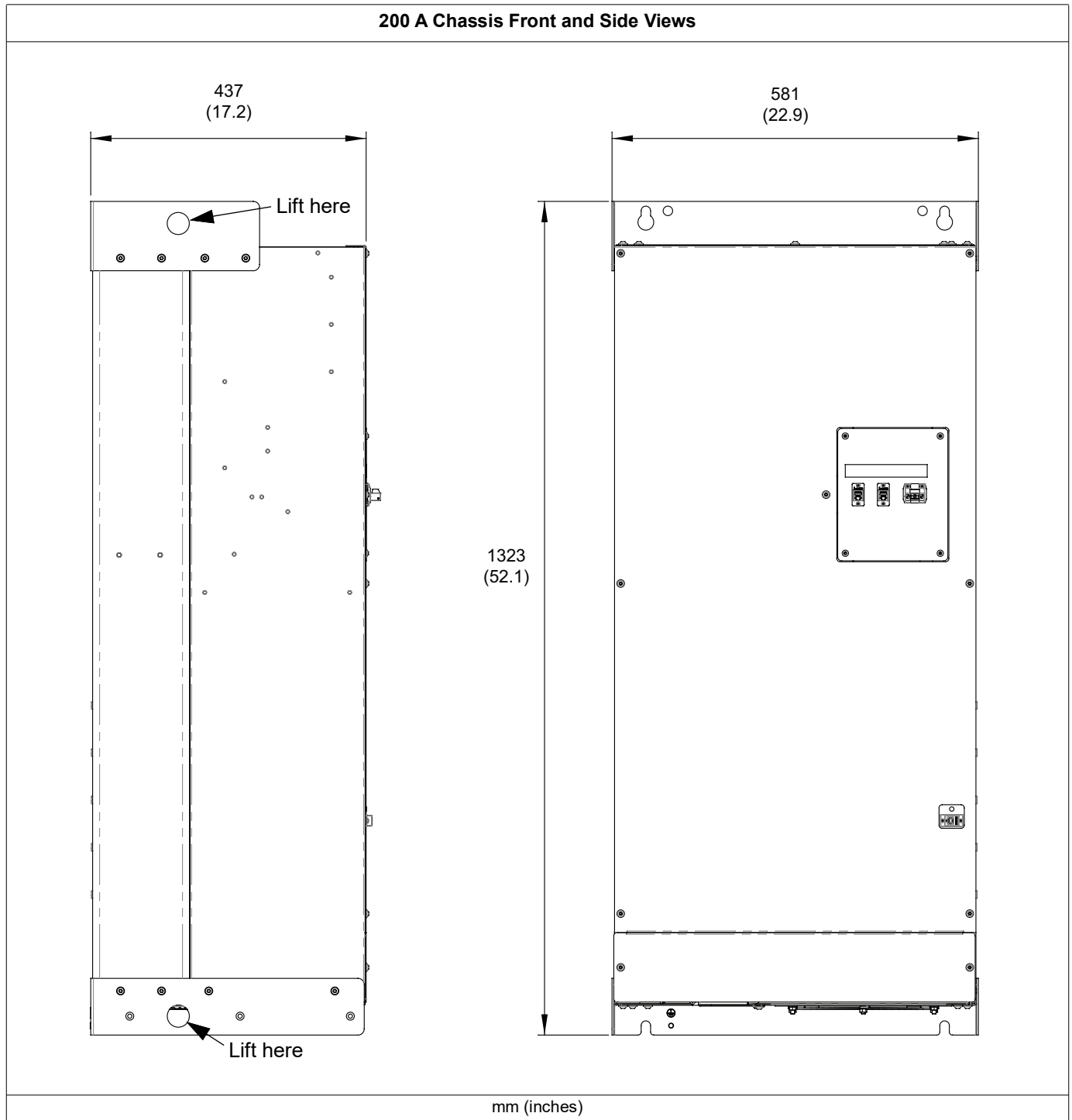

300 A Chassis Front and Side Views

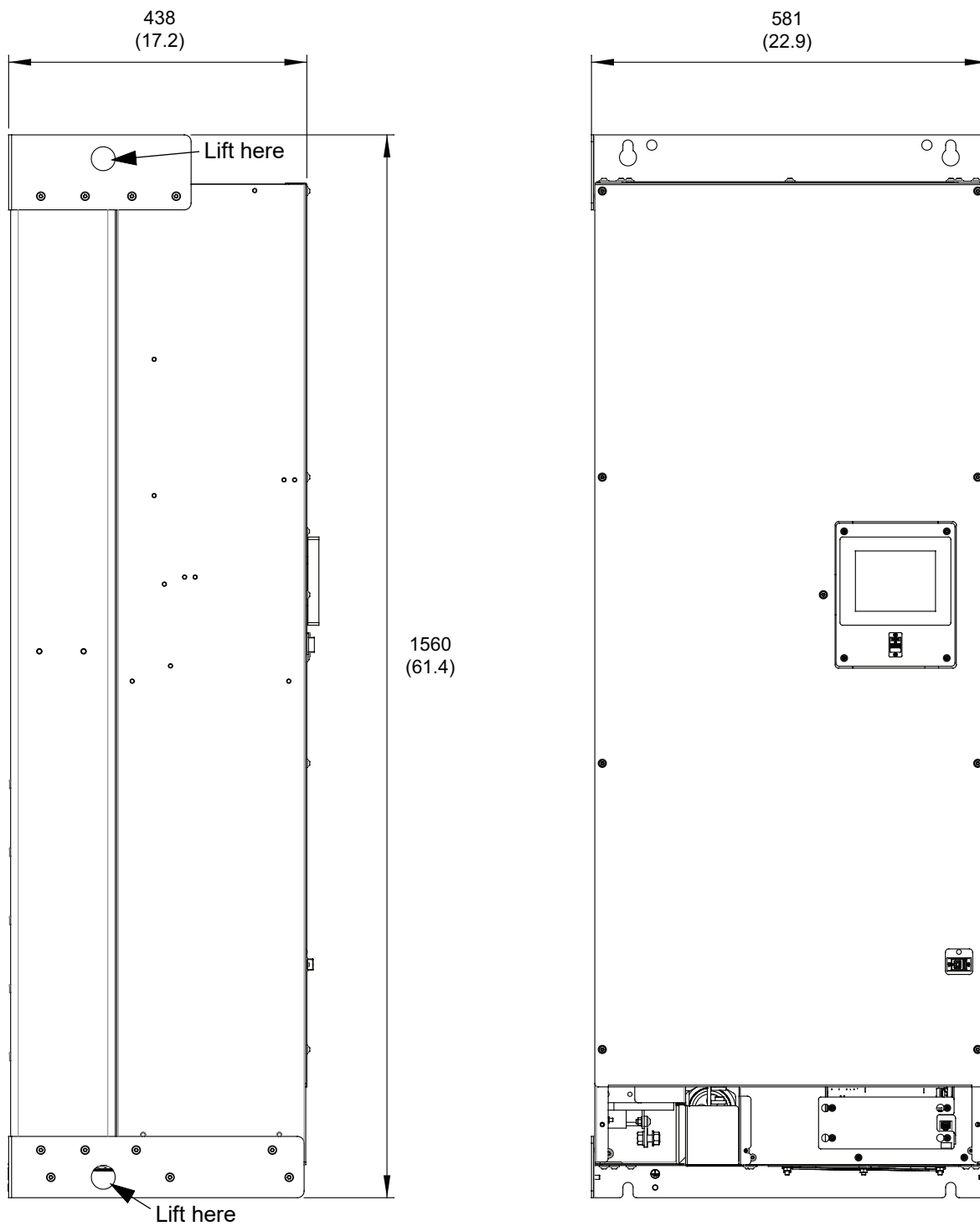

mm (inches)

Open/IP00 200 A and 300 A Top and Bottom Dimensional Drawing

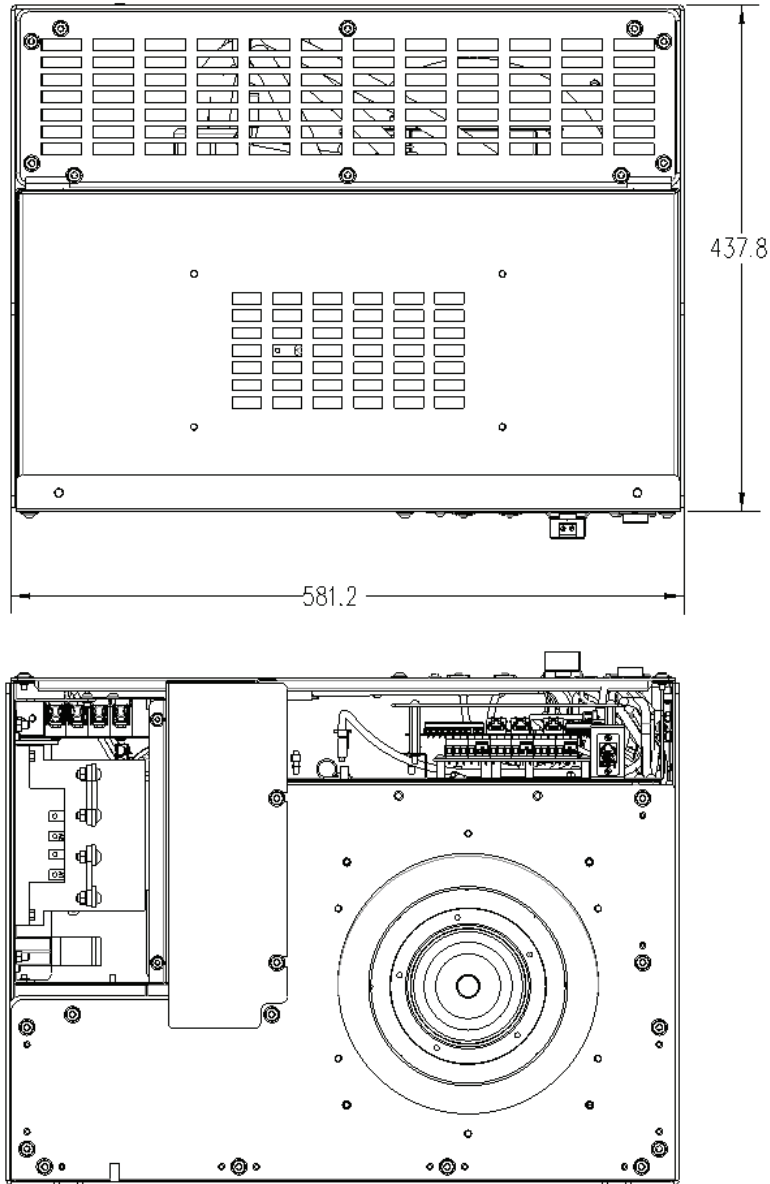

Dimensions are shown in mm

200 A IP20 Front and Side Views

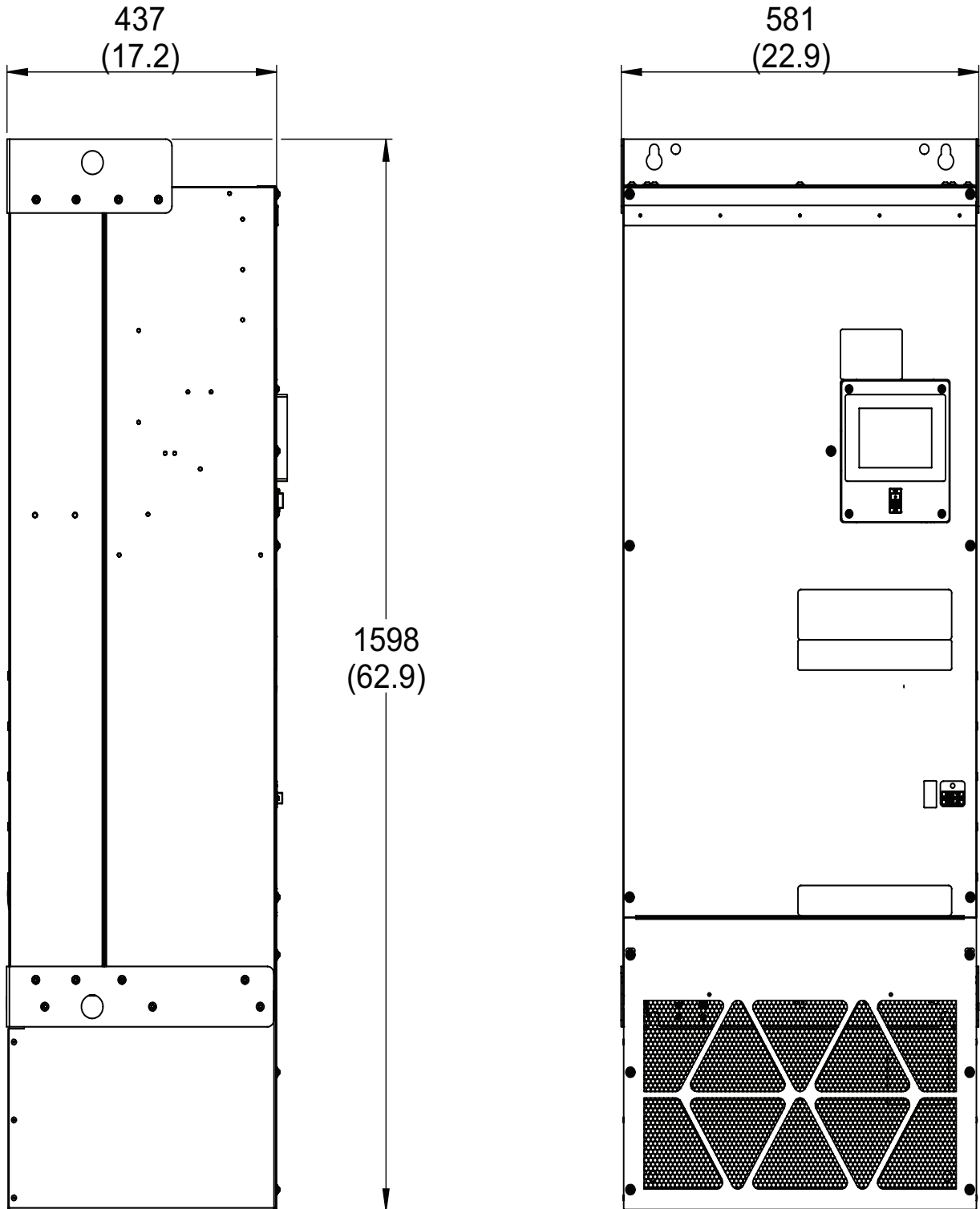

mm (inches)

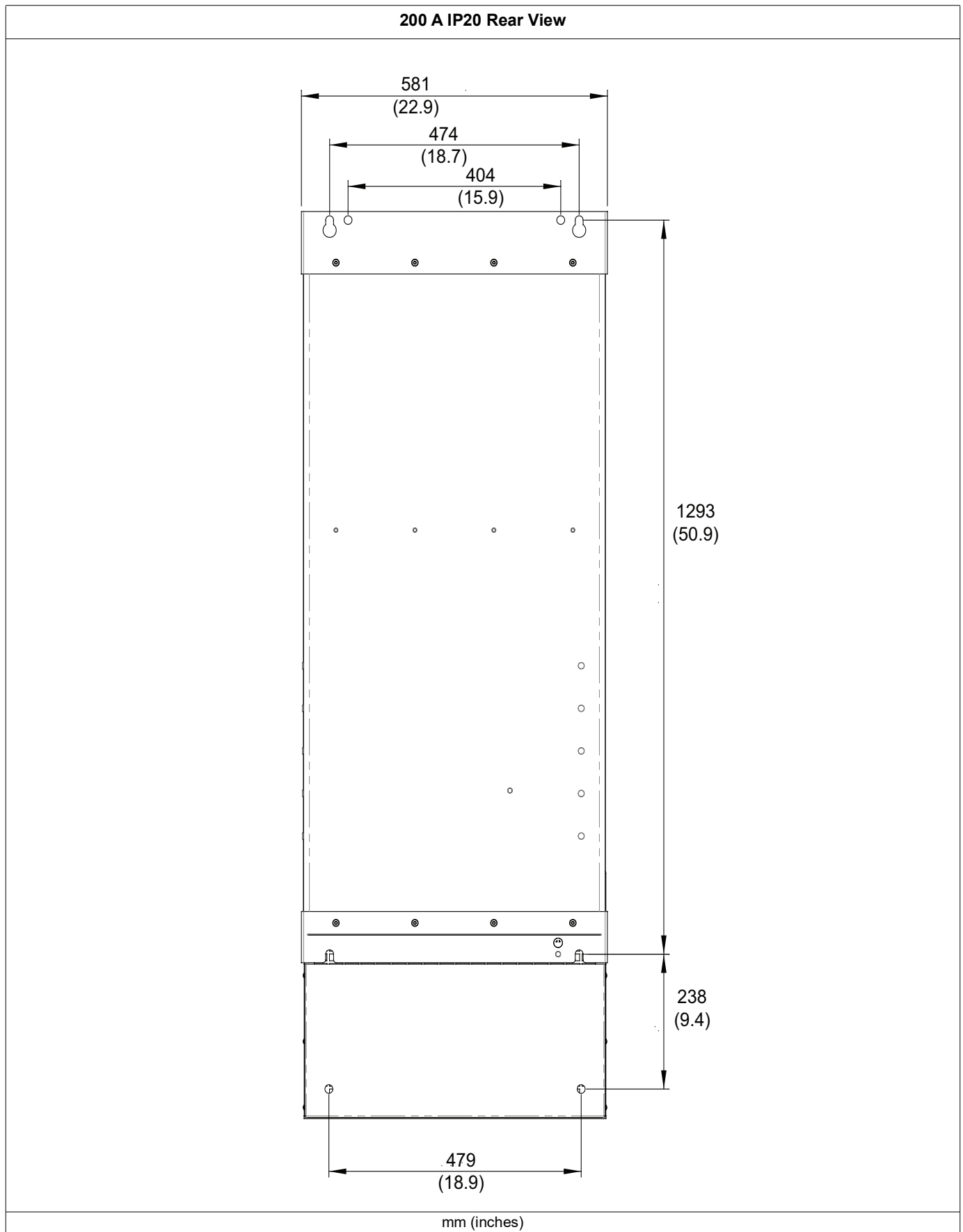

300 A IP20 Front and Side Views

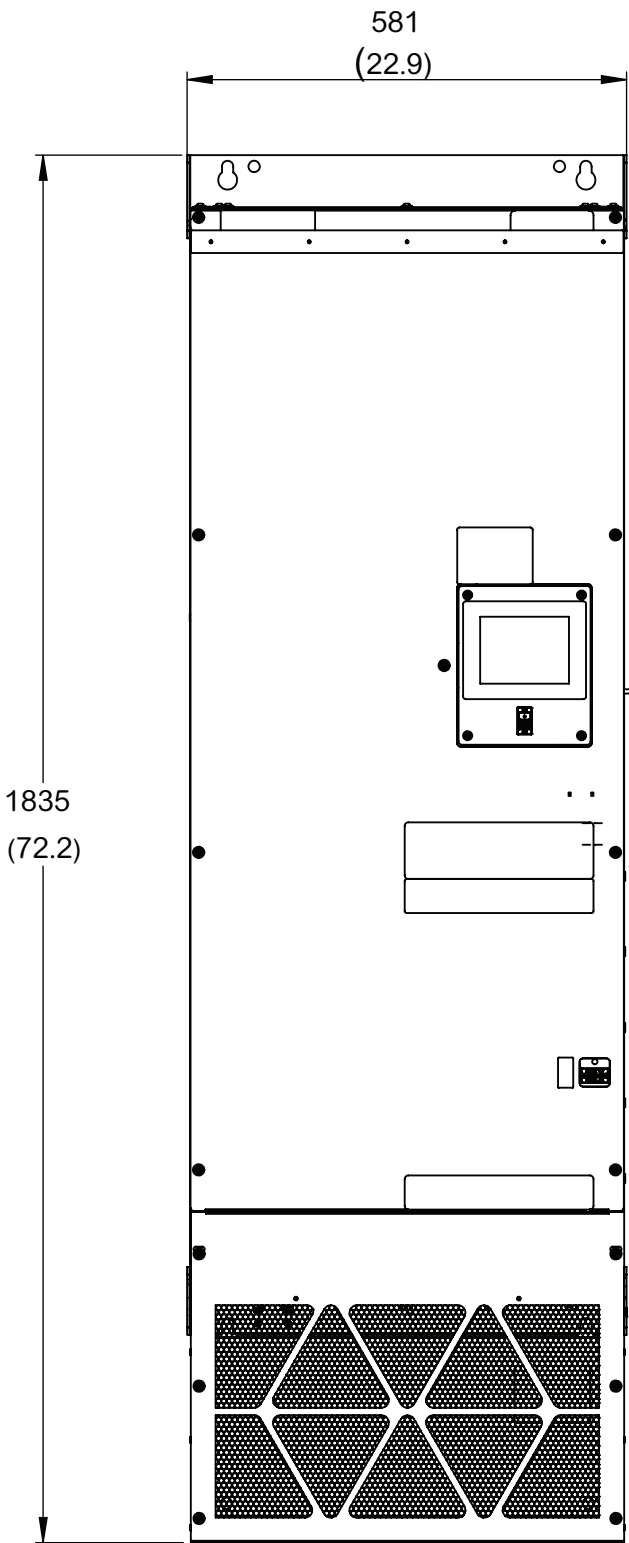
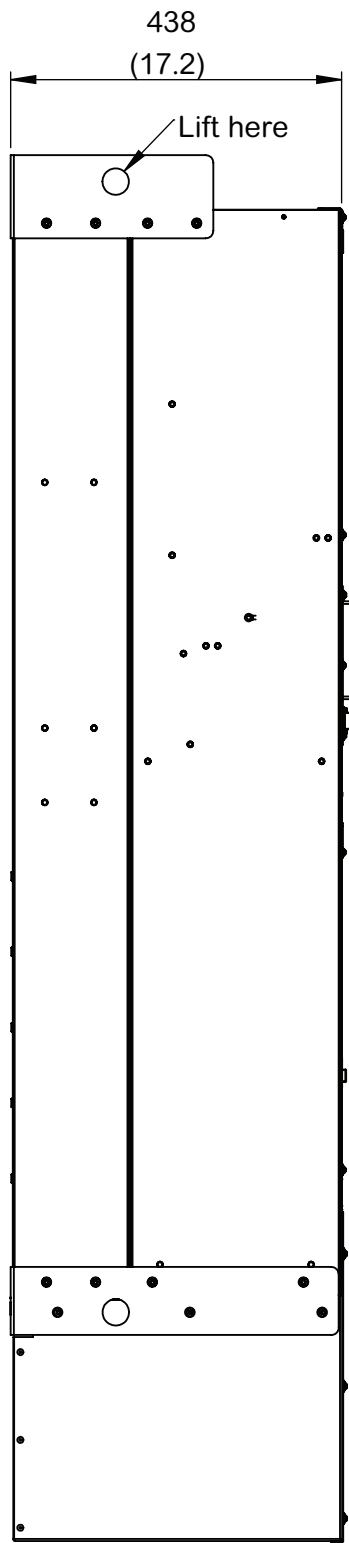

mm (inches)

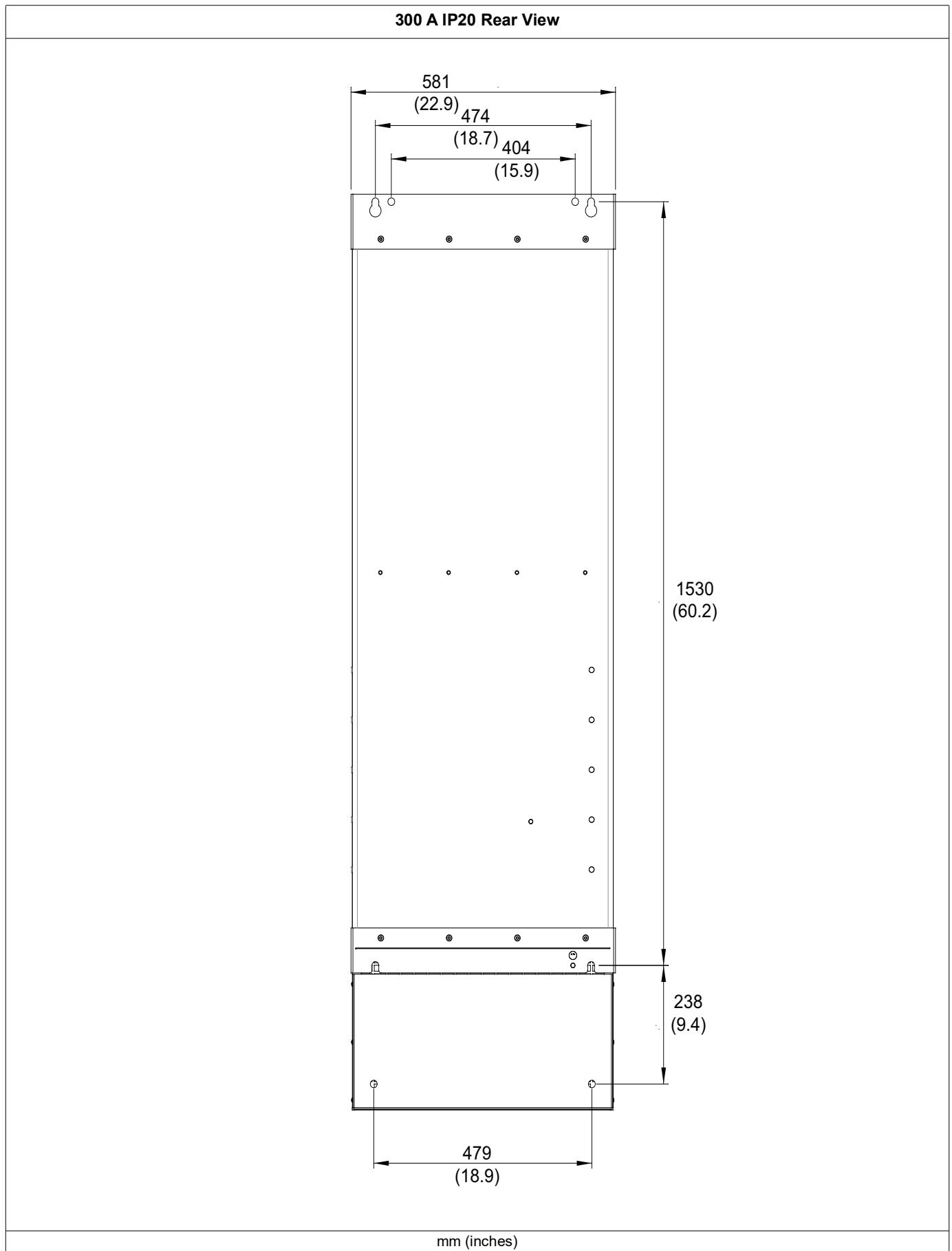

UL Type1/IP20 200 A and 300 A Top and Bottom Dimensional Drawing

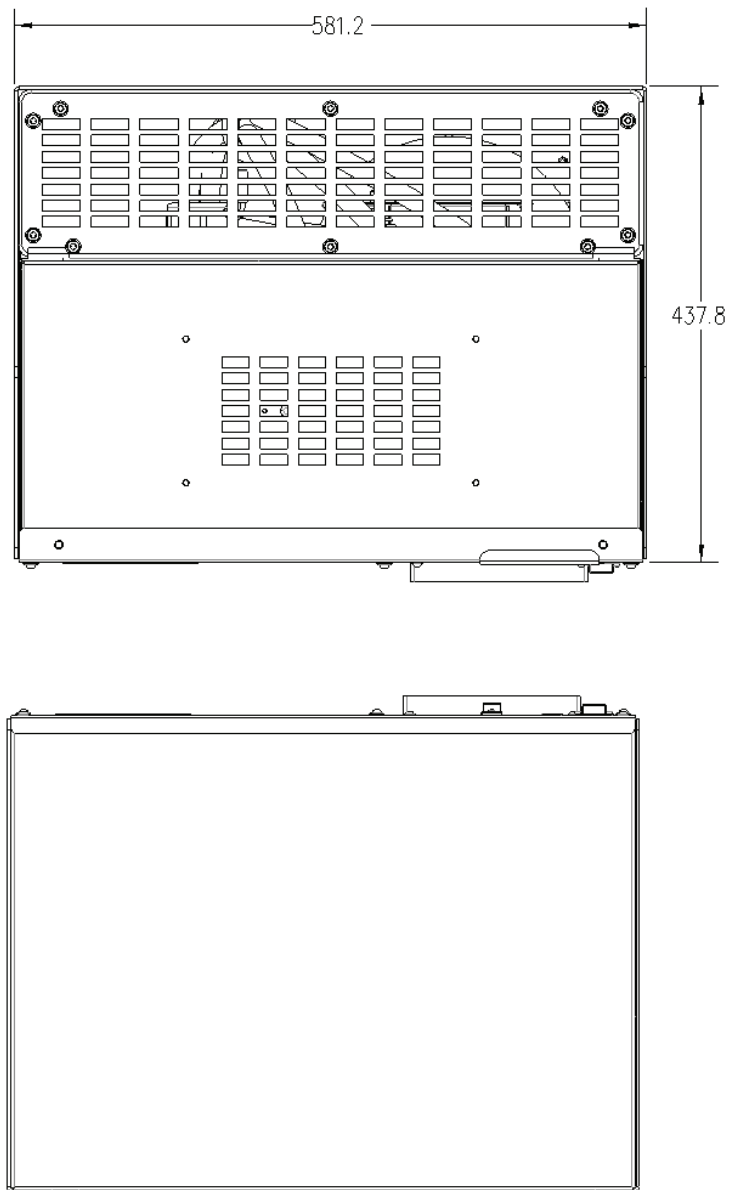

Dimensions are shown in mm

Electrical Connection

Line Voltage

Refer to Electrical Specifications 60, 120, 200 and 300 A Units to determine the line voltage that is compatible with the voltage range of the active filter.

Over-current Protection Device Selection

A dedicated over-current protection device, circuit breaker, or fuse disconnect is required for this product. The over-current protection device must be rated for at least 125% of the unit rating.

The active filter inrush current does not exceed the unit rating shown in the following table. Circuit breaker settings such as Long Time Pickup, Long Time Delay, and Short Time Pickup can be set for minimum inrush current.

Unit Rating	Minimum Circuit Ampacity	Minimum Allowable Fuse / Circuit Breaker Size	Maximum Allowable Fuse / Circuit Breaker Size
60 A	60 A	75 A	100 A
120 A	120 A	150 A	150 A (UL) / 160 A (IEC)
200 A	200 A	250 A	250 A
300 A	300 A	400 A	400 A

NOTE: Check national and local codes and regulations to ensure compliance.

Residual Current Device

NOTICE

INAPPROPRIATE TRIPPING OF PROTECTION DEVICE

Adhere to the Residual Current Device (RCD/GFCI) and Residual Current Monitor (RCM) requirements.

Failure to follow this instruction can result in a reduction in performance of the PowerLogic™ AccuSine active filter.

Direct current can be introduced in the protective ground conductor of the PowerLogic™ AccuSine active filter. If a RCD/GFCI or a RCM is used for additional protection against direct or indirect contact, the following specific types must be used:

- Use only Type B RCD/GFCI.
- RCD/GFCI with time delay set to 100 ms or greater.
- For parallel systems, provide one RCD/GFCI per unit.
- RCM must be approved for use with frequency inverters and is sensitive to all types of current.

Due to high leakage current in standard operation, it is recommended to choose at least a 500 mA device. If the installation requires a residual current device less than 500 mA, the IT/BP switches must be opened. (For more information, refer section “IT, HRG, and Corner Grounded Systems”).

Power Cable Routing

Power cables connection to the active filter must be according to the local code to help reduce noise coupling (EMI). For Open/IP00 units, power cable connections are at the bottom of the unit. For UL Type 1/IP20, see detail drawings in UL Type 1/IP20 Conversion Kit Assembly (Optional).

NOTE: In case of North America, the power cables must be placed in metal conduit or shielded encapsulated cables.

See Open/IP00 60 A Enclosure Top and Bottom Dimensional Drawing and IP00 120 A Enclosure Top and Bottom Dimensional Drawing.

For all power systems, observe the following:

- Metal conduit or the encapsulated cable shield has to be grounded to the active filter ground-terminal located adjacent to the power terminals.
- All panels must be installed to ensure proper system cooling.

Power and Ground Cable Selection and Connections

⚡ ⚠ DANGER

HAZARD OF ELECTRIC SHOCK, EXPLOSION, OR ARC FLASH

- The unit must be properly grounded before power is applied.
- Ground equipment using the ground connecting point provided.

Failure to follow these instructions will result in death or serious injury.

All power wiring has to be routed directly from the conduit entry plate to the terminations on power terminals (and the earth grounding terminal) without loops. Instrumentation and CT wiring has to be routed in a separate conduit to the power cables. A dedicated ground conductor must be used when installing the active filter.

NOTE:

- Metal conduit shall be grounded or use shielded encapsulated cable.
- All wiring must follow the local wiring code.

When used as a harmonic current compensation device, the active filter produces currents at frequencies that are multiples of the AC line fundamental frequency. Power cables as well as input disconnect devices should be rated at 125% of the active filter rated current. This helps avoid excessive heating from any skin effect resistance increase at these higher frequencies.

NOTE: Check national and local codes and regulations to ensure compliance.

Box lug accessory kits are available as an option in the catalog. The box lugs are UL compliant. Each kit contains three box lugs for the phase connection and one box lug for the ground connection. When installing 200 A or 300 A units, two box lug kits are required per unit if two conductors per phase are used.

The box lugs in the optional accessory kit are not IEC compliant. For IEC installation, use crimp-on ring lugs for electrical connections.

Electrical Specifications 60, 120, 200 and 300 A Units

Active Filter	Total Current Amperes	Voltage Range Volts	Wire Temperature Rating	Power Connection Type	Power Connection Torque N•m (lb-in) ± 5%	Ground Connection Stud Size	Ground Connection Torque N•m (lb-in) ± 5%	No. Conductors Per Phase
60 A	60	208...240 or 380...480	60 °C, 75 °C, 90 °C	M6 Stud	7.5 (66.4)	M8	18.2 (161.1)	1
120 A	120	208...240 or 380...480	75 °C, 90 °C	M8 Stud	15 (132)	M8	15 (132)	1
200 A	200	208...240 or 380...480	75 °C, 90 °C	10 mm Hole	36.5 (323.1)	M8	18.2 (161.1)	1 or 2
300 A	300	208...240 or 380...480	75 °C, 90 °C	10 mm Hole	36.5 (323.1)	M8	18.2 (161.1)	1 or 2

NOTE: Check national and local codes and regulations to ensure compliance.

60 A Models

60 A IP00 Customer Connections

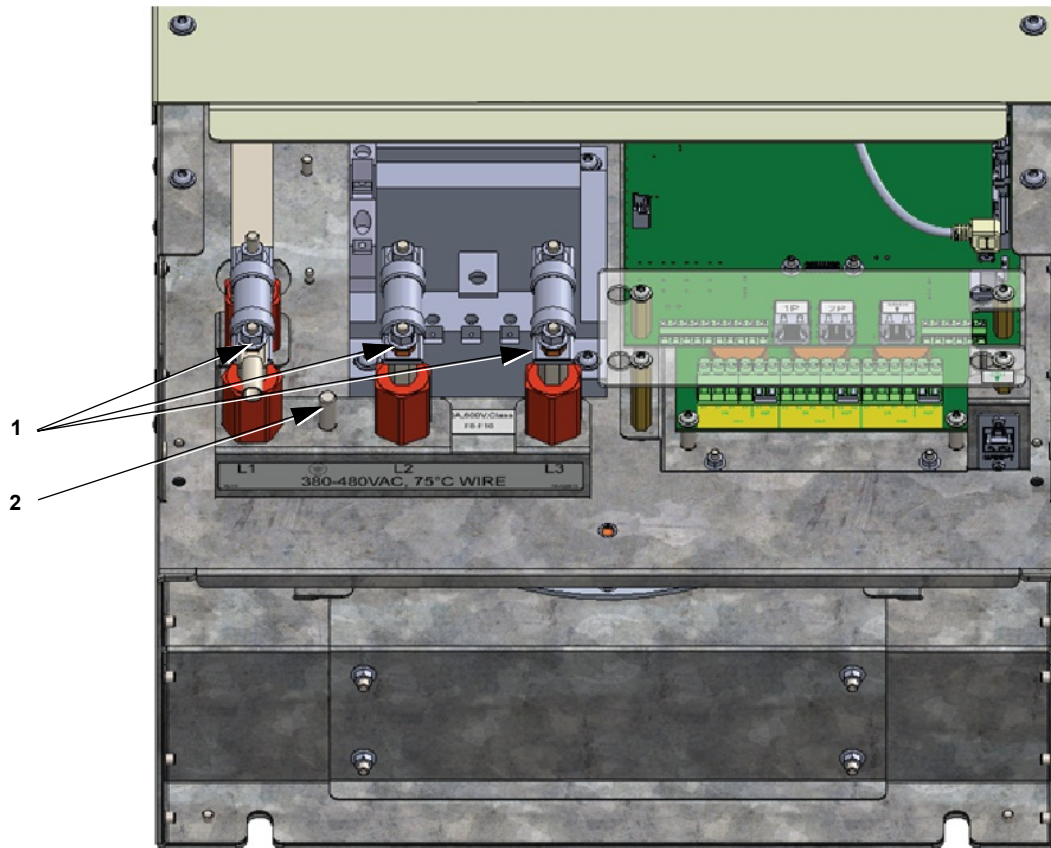

1. Power Terminals
2. Ground Bond

The power terminals are M6 studs. The ground terminal is an M8 stud.

Use either a crimp ring lug or box lug to make connections. Refer to the catalog for box lug part numbers.

1. Using a 10 mm socket, torque the power connections to 7.5 N•m (66.4 lb-in).
2. Using a 13 mm socket, torque the ground connection to 15 N•m (132 lb-in).

NOTE: Power and ground nuts are provided in the chassis packaging.

3. Remove nuts and washers from the bottom of the fuse.
4. Install ring lug or box lug directly to the bottom of the fuse blade.

120 A Models

120 A IP00 Customer Connections

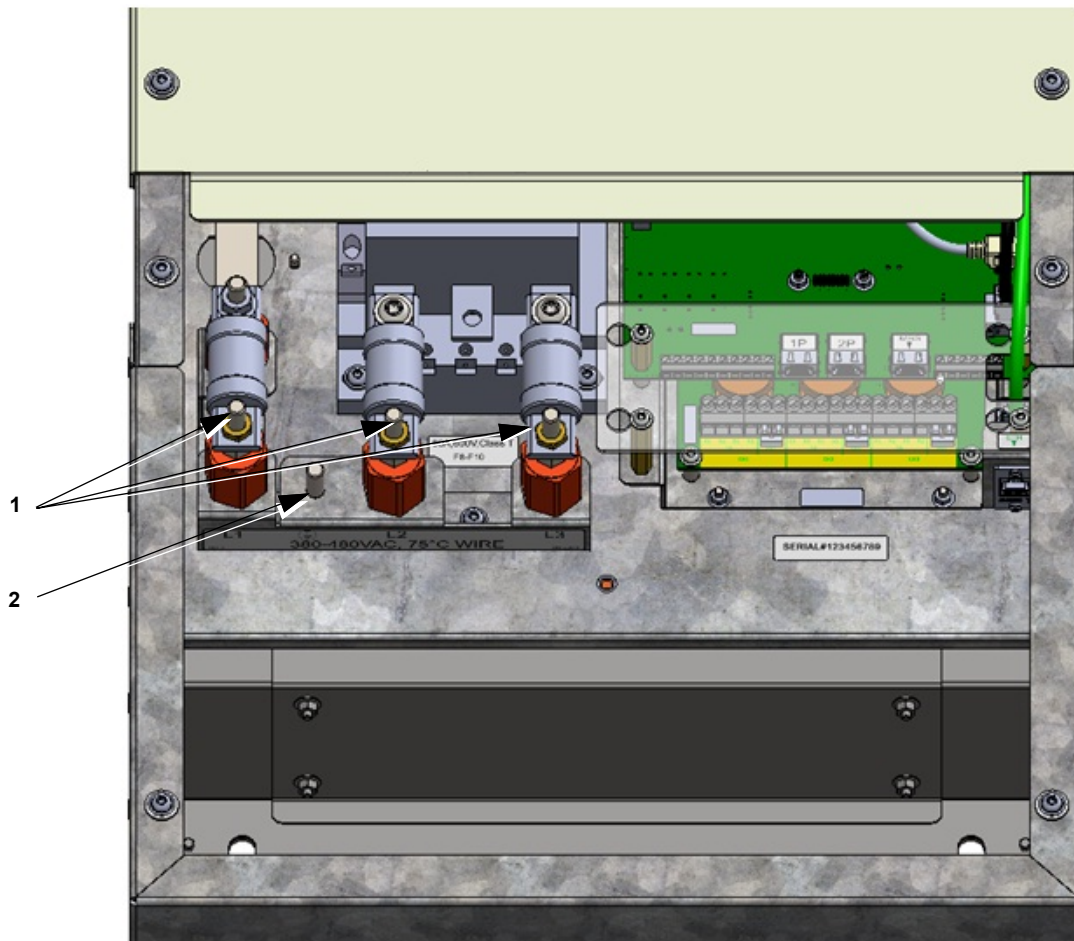

1. Power Terminals
2. Ground Bond

The power terminals and the ground terminal are M8 studs.

Use either a crimp ring lug or box lug to make connections. Refer to the catalog for box lug part numbers.

1. Using a 13 mm socket, torque all connections to 15 N•m (132 lb-in).

NOTE: Power and ground nuts are provided in the chassis packaging.

2. Remove nuts and washers from the bottom of the fuse.
3. Install ring lug or box lug directly to the bottom of the fuse blade.

Access Cover Removal

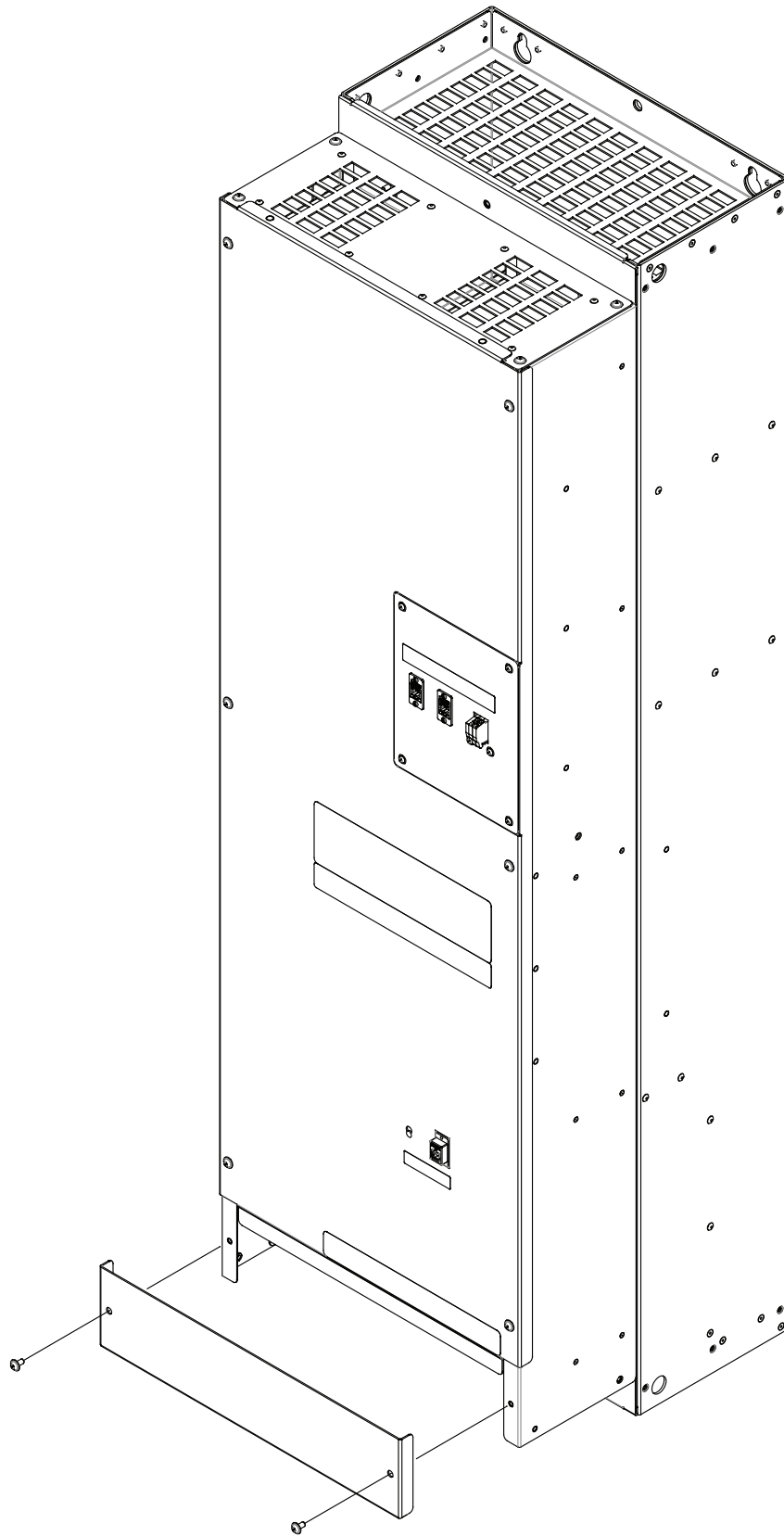

200 A and 300 A Models

200 A and 300 A Power and Ground Terminations

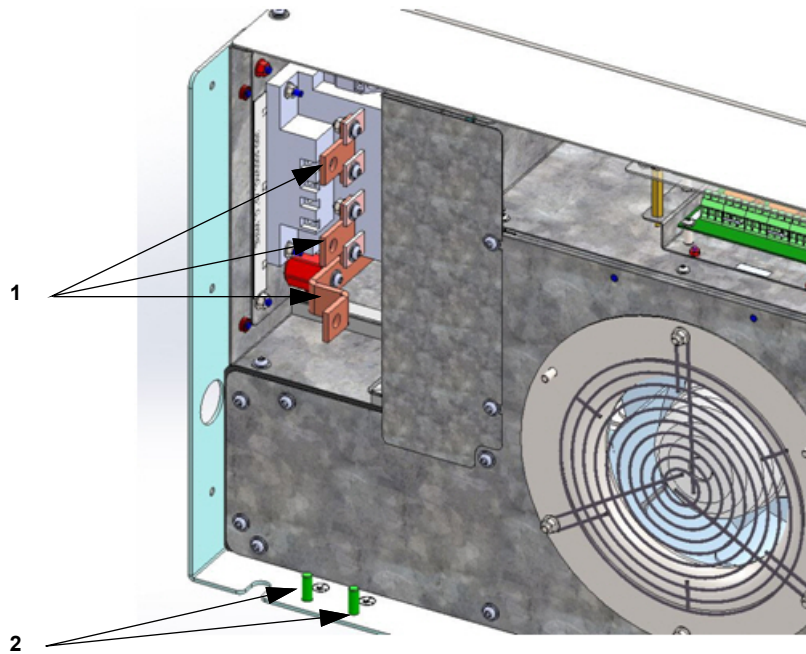

1. Power Termination
2. Ground Termination

The power terminals are provided with a 10 mm hole. The unit has three 40 mm long bolts, three nuts, and six washers included for power termination.

The ground terminal is an 8 mm stud. Two nuts are provided for the ground termination.

NOTE: Two ground terminals are provided if local codes require additional grounding. Otherwise, one ground connection is sufficient.

1. Using a 17 mm socket or combination wrench, torque the power connections to 36.5 Nm (323.1 lb-in).
2. Using a 13 mm socket, torque the ground connection to 18.2 Nm (161.1 lb-in).

Current Transformers (CTs)

DANGER

HAZARD OF ELECTRIC SHOCK, EXPLOSION, OR ARC FLASH

- Never open circuit a current transformer (CT).
- Always use grounded external CTs for current inputs.

Failure to follow these instructions will result in death or serious injury.

Ensure that CT secondary current is not present when wiring the CT secondary connections. The shorting jumpers must be installed at the X1 to X2 OUT of each CT channel on the CT board unless you are connecting an additional Primary parallel unit. Refer to Source Side CT Position Diagram

General CT Information

The CT must be orientated properly during installation. The orientation is specified in the drawings with an arrow indicating the direction or polarity of the CT. Most CT manufacturers will indicate orientation with a label indicating H1 on one side of the CT or a dot. There can also be a label indicating H2 and/or an arrow on the CT. The H1 side of the CT should always be closest to the power source. If the CT has an orientation arrow, it should point from the source towards the load. See the installation instructions for the specific CTs being installed.

A shorting terminal block or shorting switch with galvanic isolation to the active filter for the CT secondary is required. Insert an interposing terminal block in a separate enclosure with the ability to short the secondary wiring of the CT. This provides the ability to short the CT without entering the active filter enclosure (which otherwise would require a power shutdown). Shorting terminal blocks are available in the catalog.

CT location is defined in relationship to the active filter system. CT location on the “Source Side” indicates that the CTs are physically located upstream of the active filter. The CTs will measure the improvement to the current as a result of the active filter operating. A CT location on the “Load Side” indicates that the CTs are downstream of the active filter. The CTs will monitor the Load current provided by both the source and active filter currents.

Two CTs are required to be installed, one on L1 phase and one on L2 phase of the conductors powering the loads to be compensated by the active filter system. If there are any line-to-neutral connected loads downstream of the active filter system's main CTs, a third CT is required on L3 phase.

NOTICE

MEASUREMENT ERRORS

CTs must be physically separated from any perpendicular conductor by at least 25 mm (1 in) for every 1000 A of current flowing through the perpendicular conductor.

Failure to follow this instruction can result in a reduction in performance of the active filter.

If this practice is not followed, the magnetic field produced by the current flowing on the perpendicular conductor will cause CT measurement errors.

Minimum CT Requirements

The active filter uses a minimum of two external current transformers (CTs) to measure load current waveforms. Standard CTs rated for 50/60 Hz or 400 Hz with Type 1 accuracy rating, with a 5 A or 1 A secondary are acceptable. The largest primary rating for the CT is 10,000 A. Any splicing to the CT leads needs to be done with crimp style connectors or soldered.

The CT should be mounted on phases L1 and L2 with the orientation arrow pointing toward the load. Systems that are using two CTs can have the CTs installed on L1 and L3 or L2 and L3 if necessary. If L1 and L3 or, L2 and L3 CT configurations are used, this information must be provided to the qualified person commissioning the unit. Three external CTs are required if line-to-neutral connected loads are present.

NOTICE

REDUCED PERFORMANCE

CT wiring must be routed separately from power cables.

Failure to follow this instruction can result in a reduction in performance.

CT wiring must be routed directly from the conduit entry-plate to the terminal block of the CT board.

CT must be selected for:

- 5 A or 1 A secondary
- 250 to 10,000 primary rating
- 50/60 Hz or 400 Hz Rated
- Type 1 accuracy
- The CT primary current rating must exceed the maximum load current where they are installed;
- The maximum burden (in VA) on the CT is formed by the CT wiring and total active filter burden. This is equal to 1.0 VA for CTs with a 5 A secondary rating or 0.04 VA for CTs with a 1 A secondary rating.
- The maximum wire size of the CT secondary is 2.5 mm² / 12 AWG. Consult the CT manufacturer for secondary wiring recommendations. See "Maximum Wire Length" tables on page 45.

CT secondary wiring must be either twisted and/or shielded pairs.

Do not connect the active filter CT to any other loads. Use a separate current transformer if additional uses are required.

Any splicing to the CT leads needs to be done with crimp style connectors or soldered.

X2 of each CT installed must be grounded as close to the CT as possible.

A single active filter, not operating in parallel, can have the CTs installed either on the source side or load side of the active filter. Parallel systems must have the main CTs installed on the source side of the active filter system.

CT to CT Board Connection

The CT connection is made behind the small customer access panel at the bottom of the active filter chassis. See Access Cover Removal. Remove the customer access panel. The CT board is located behind and slightly below the control board. This is the location where the active filter CT secondary wiring must be terminated. Remove the clear plastic safety cover to access the CT board.

Typically, L1 CT will be connected to CH1 IN. There are two X1 and X2 IN terminals. The second set of IN terminals can be used to connect additional CTs that may be required for site specific conditions. X1 and X2 OUT are used for parallel active filter systems.

NOTICE

CIRCULATING CURRENTS

When using shielded CT secondary wire, only ground the shield at one end of the cable.

Failure to follow this instruction can result in a reduction in performance.

NOTICE

INACCURATE FILTER OPERATION

Do not allow the conductor on which the CT is mounted to become lodged in the joint area of a split-core CT.

Failure to follow this instruction can result in inaccurate filter operation.

DANGER

HAZARD OF ELECTRIC SHOCK, EXPLOSION, OR ARC FLASH

The factory provided shorting jumpers must be installed at the OUT of the CT board of the last unit with CT secondary wiring connected.

Failure to follow these instructions will result in death or serious injury.

Maximum Wire Length

5 A Secondary Maximum Wire Length

Maximum wire length from active filter to CT in meters		
CTs burden capacity with 5 A secondary rating	1.5 mm ²	2.5 mm ²
5 VA	15	24
15 VA	51	84
25 VA	87	143
30 VA	105	173
35 VA	124	203
45 VA	160	263

Maximum wire length from active filter to CT in feet		
CTs burden capacity with 5 A secondary rating	14 AWG	12 AWG
5 VA	65	103
15 VA	228	361
25 VA	390	619
30 VA	472	748
35 VA	553	877
45 VA	715	1135

1 A Secondary Maximum Wire Length

Maximum wire length from active filter to CT in meters		
CTs burden capacity with 1 A secondary rating	1.5 mm ²	2.5 mm ²
5 VA	451	740
15 VA	1360	2233
25 VA	2269	3725
30 VA	2724	4472
35 VA	3178	5218
45 VA	4087	6710

Maximum wire length from active filter to CT in feet		
CTs burden capacity with 1 A secondary rating	14 AWG	12 AWG
5 VA	2016	3200
15 VA	6081	9652
25 VA	10146	16103
30 VA	12179	19329
35 VA	14211	22555
45 VA	18276	29006

Source Side CT Position Diagram
(CT's installed on the "Source Side" or upstream of the active filter)

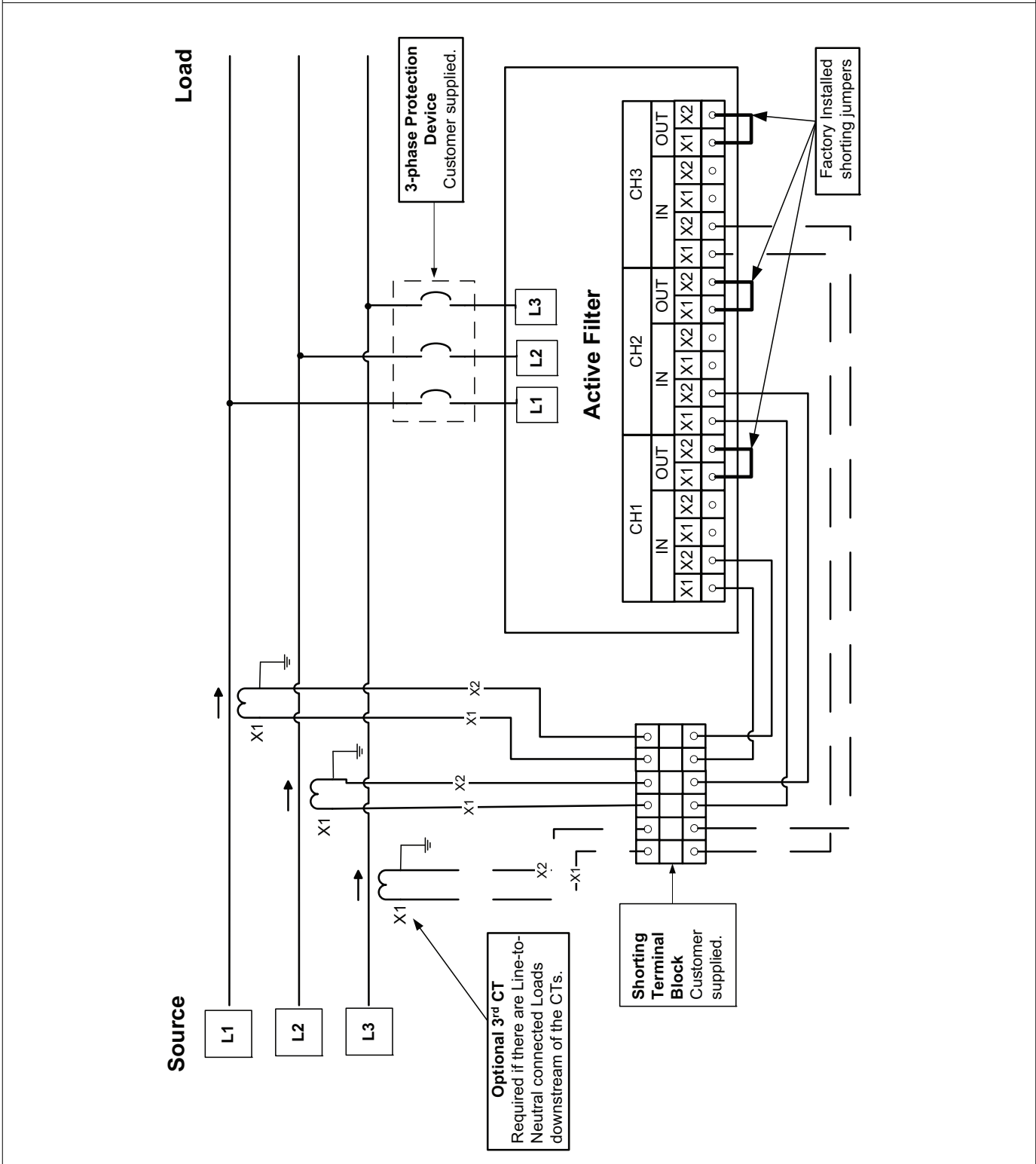

NOTE: The factory installed shorting jumpers must be installed.

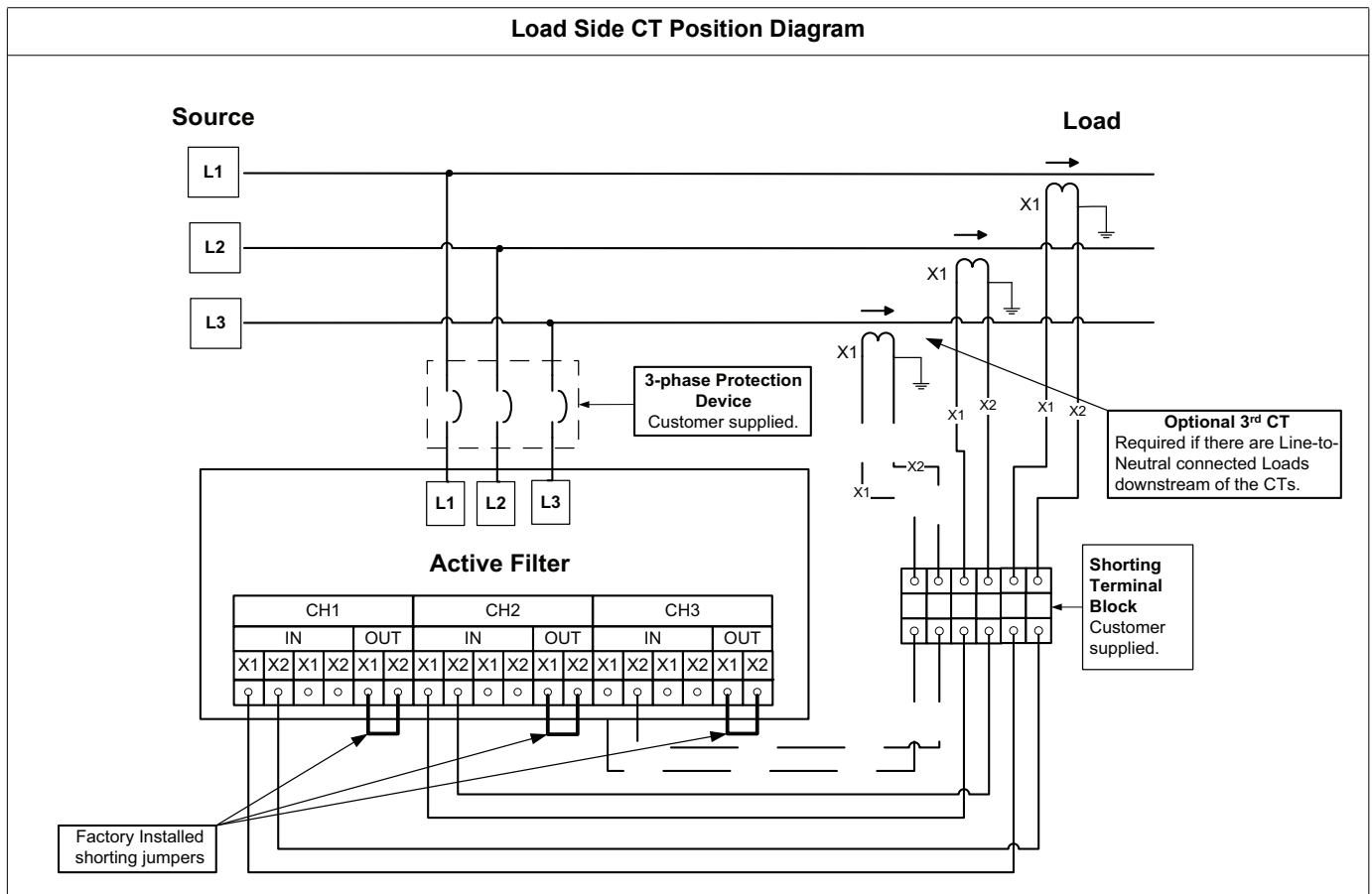

NOTE: The factory installed shorting jumpers must be installed.

Parallel System

Up to ten active filters can be installed in parallel. If more than ten units in parallel are required, contact the local sales representative for assistance prior to installation.

CT Installation Parallel Units

DANGER

HAZARD OF ELECTRIC SHOCK, EXPLOSION, OR ARC FLASH

The factory provided shorting jumpers must be installed at the OUT of the CT board of the last unit with CT secondary wiring connected.

Failure to follow these instructions will result in death or serious injury.

The active filters can be set up to be either Primary or Follower. To be a candidate as a Primary, the unit must be provided with CT secondary wiring to the CT board. See Control Board and CT Board Detail. There is no limit to the number of units that can be set up as a Primary candidate. At least two units should be capable of being the Primary in any parallel installation.

The main CTs must be installed on the source side of the parallel active filter system. Examples of CT secondary wiring can be seen on the following pages in this section. Refer to Over-current Protection Device Selection for information on circuit breaker and fuses required.

Source Side CT Position Parallel Units Diagram

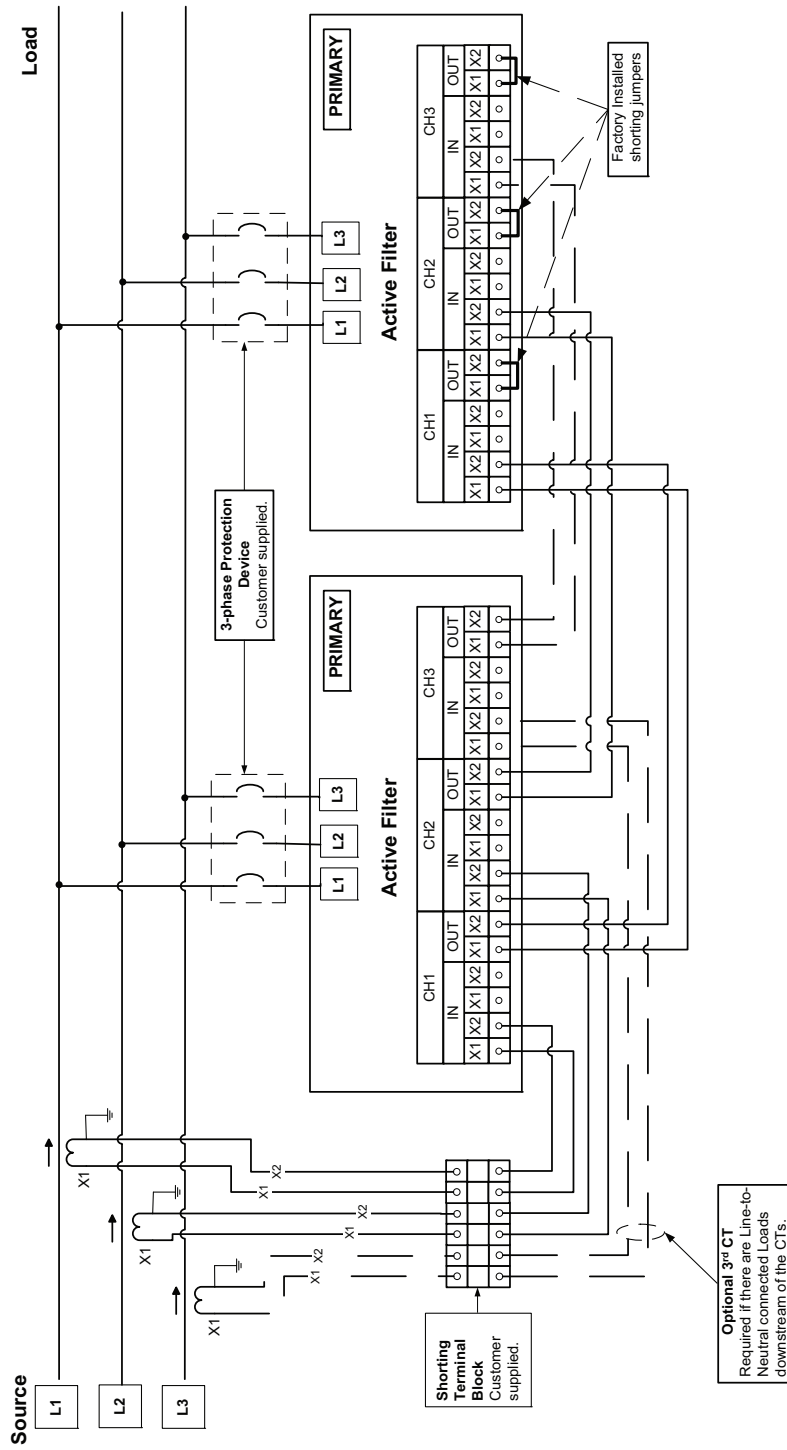

CT Wiring for 3 Primaries

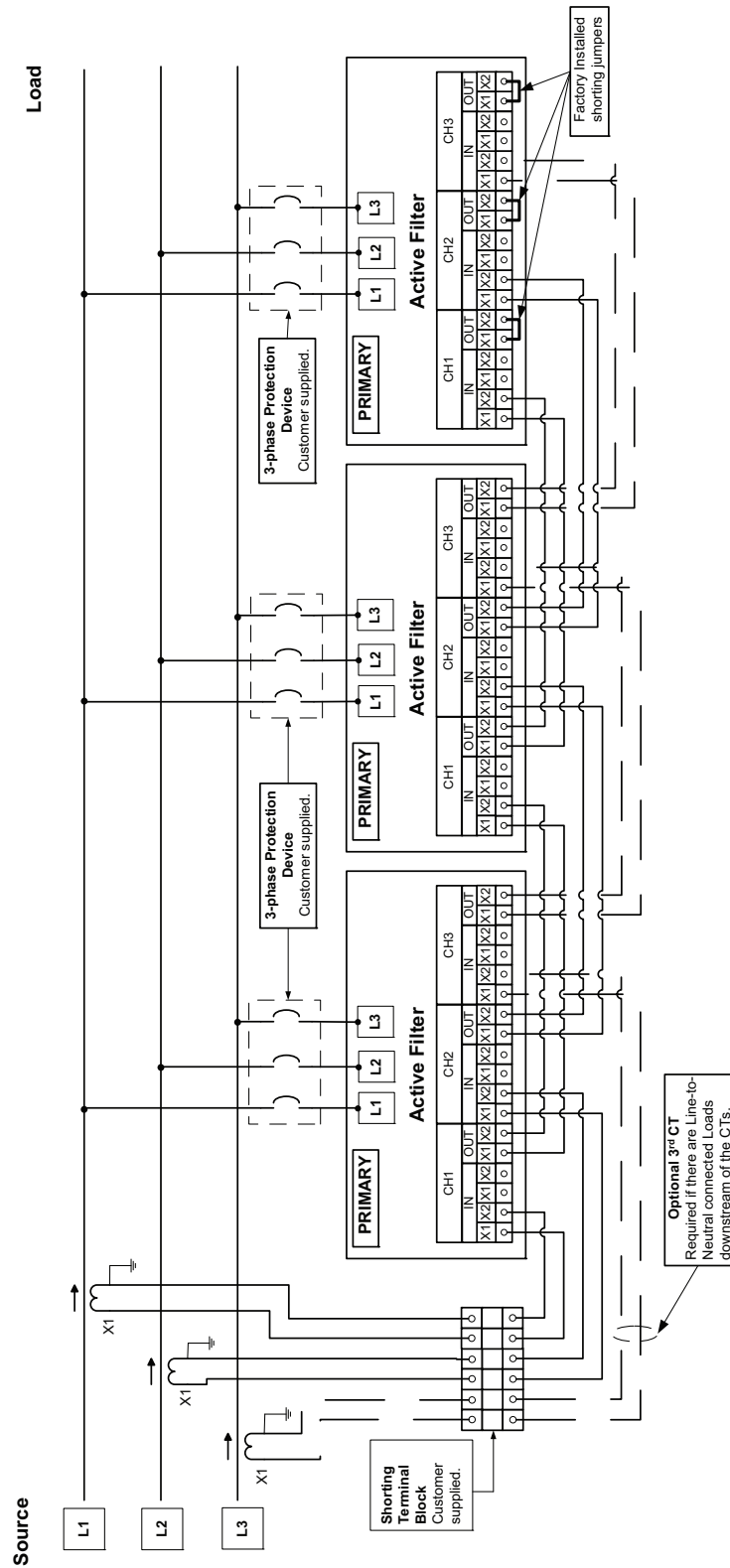

CT wiring for 2 Primaries and 1 Follower

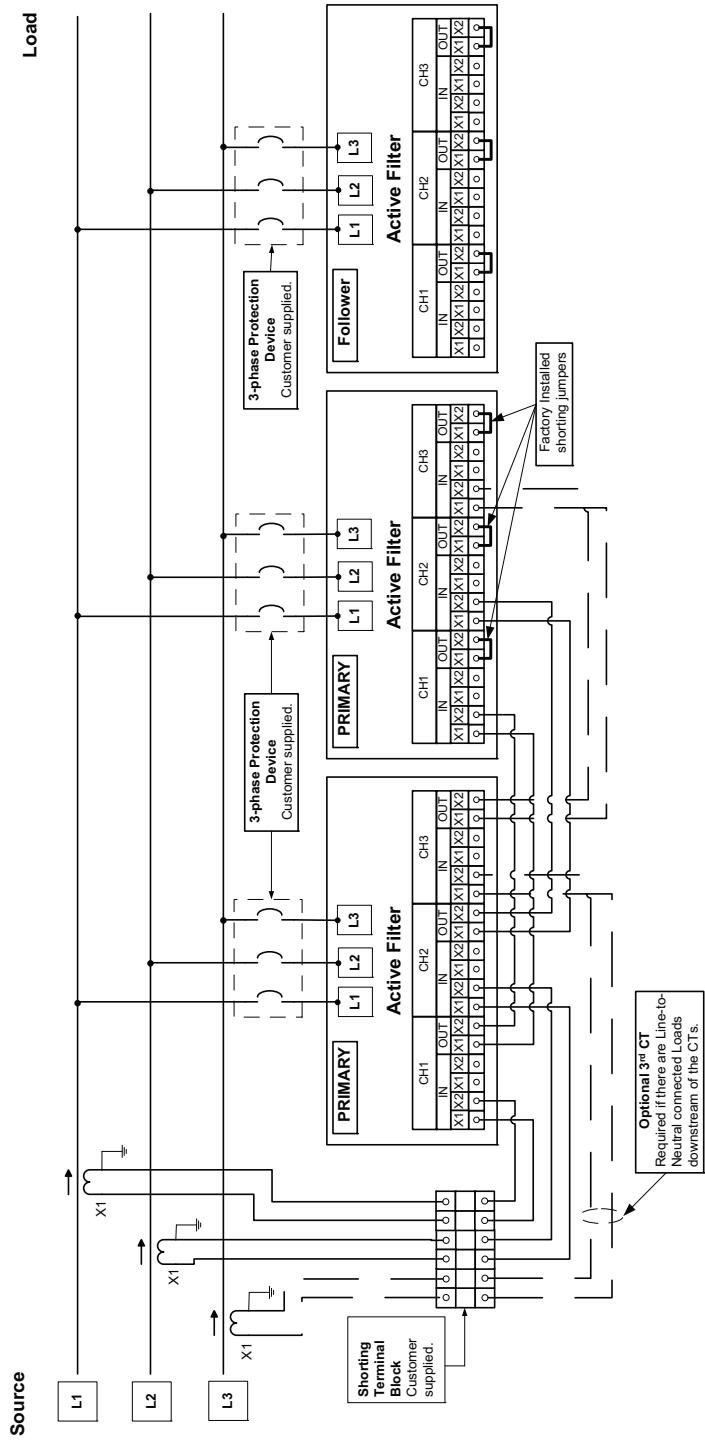

CT wiring for 2 Primaries and 3 Followers

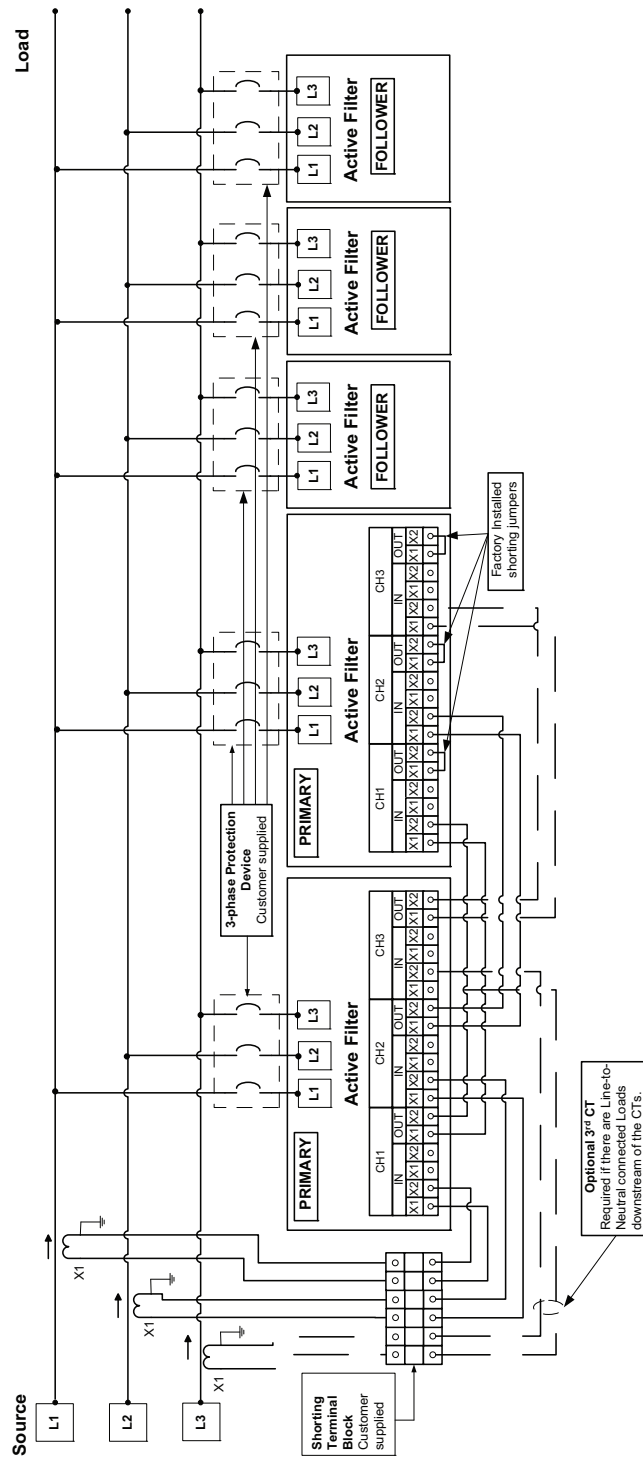

Parallel Communication

For parallel operation, the units communicate through the RJ-45 connectors labeled 1P and 2P on the Control Board. This is a unique communication protocol that is only to be used for parallel communication. The 2P jack has an RJ-45 termination plug installed at the factory.

NOTICE

EXCESSIVE NOISE IN THE COMMUNICATION CIRCUIT

When the unit is set to operate in parallel mode, the termination plug must be installed in any RJ-45 jacks that are not used for parallel communication wiring. See the wiring diagrams in this section.

Failure to follow this instruction can result in communication errors.

CAT5e cable with all 8 conductors terminated at the RJ-45 connections is required for parallel communication. It is recommended that shielded Cat5e cable be used. Ensure that the total cable length does not exceed 76 meters (250 feet). The CAT5e cable with RJ-45 plugs can be purchased as an option. Refer to the catalog for optional paralleling cable part numbers.

Control Board and CT Board Detail

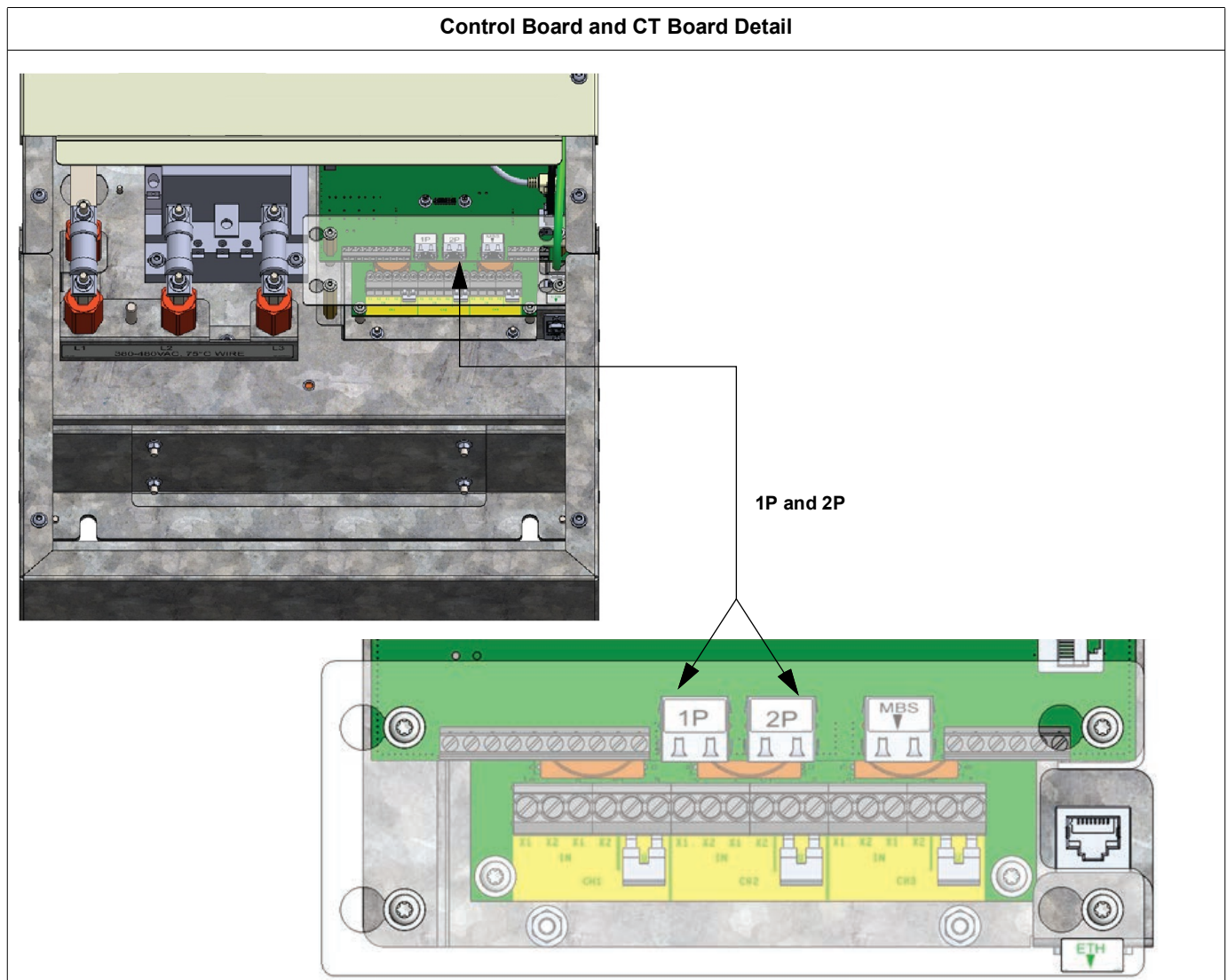

2 Unit Parallel Communication Wiring Diagram

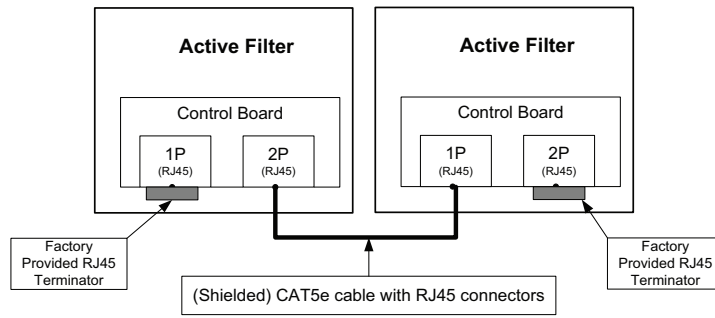

4 Unit Parallel Communication Wiring Diagram

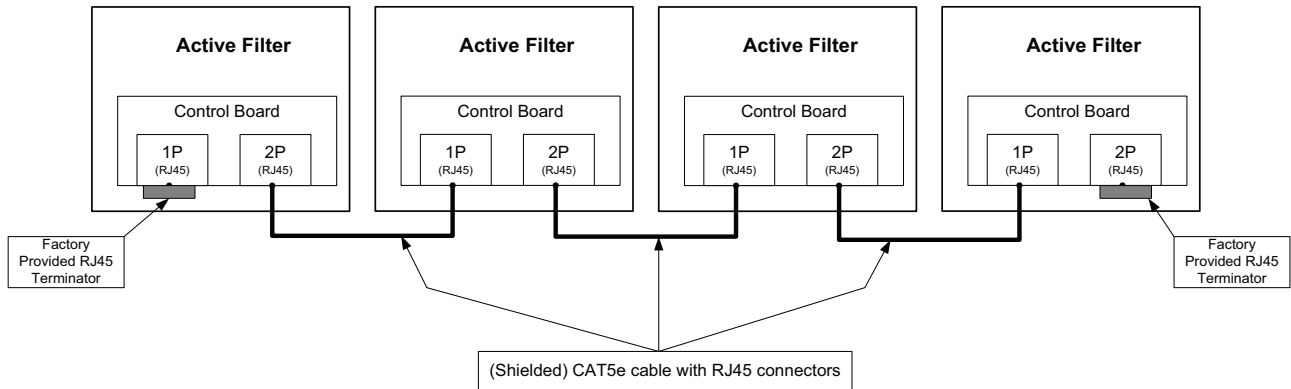

Control Wiring

Dry Contact output

Four dry Contact outputs are available at J2 of the Control Board. See Control Board and CT Board Detail. One common and four switchable outputs are available labeled Q1 to Q4. The four outputs can be programmed to change states on different conditions by the HMI and be set to either normally open or normally closed. See the User Manual for setting the output contacts. Maximum voltage accepted is 250 V AC or 30 V DC with a 0.5 A maximum current per Dry Contact.

Digital Input Control

Four input controls are available at J2 of the Control Board. See Control Board and CT Board Detail. One Ground and four inputs labeled I1 to I4. The inputs are at 5 V DC and are grounded to activate. The control function can be programmed by the HMI. See the User Manual for setting the functionality of the input control.

Modbus TCP/IP

Modbus TCP/IP monitoring is available at the RJ-45 jack to the right of the Control Board labeled ETH. Refer to Control Board and CT Board Detail. Modbus addresses are provided in the User Manual.

Modbus Serial

A serial Modbus connection is available through an RJ-45 jack labeled MBS on the control board. Refer to Control Board and CT Board Detail. Modbus addresses are provided in the User Manual.

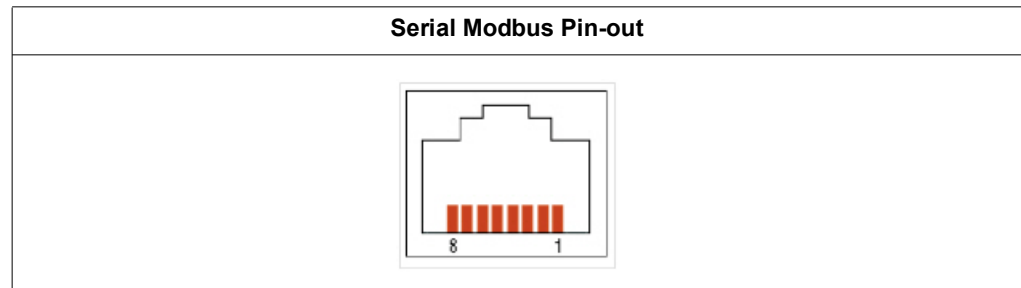

Pin	Signal Name	Direction	Meaning
1	Not connected	-	
2	Not connected	-	
3	Not connected	-	
4	D1	Input/Output	Transfer data (RS-485)
5	D0	Input/Output	Transfer data (RS-485)
6	Not connected	-	
7	Not connected	-	
8	SG	-	Signal ground

Control Board and CT Board Detail

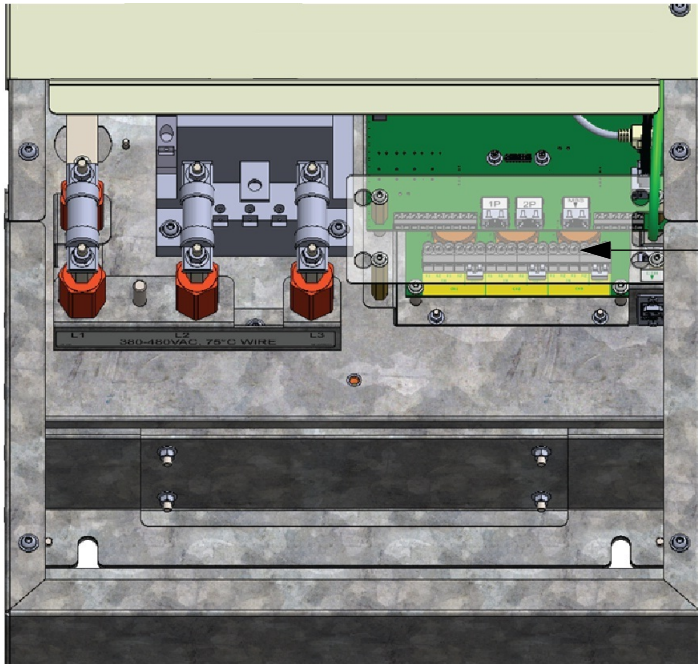

J2

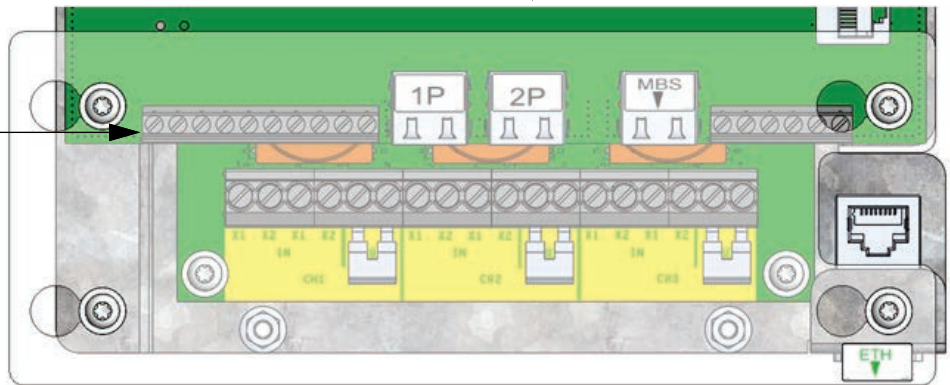

Control Board J2 Detail

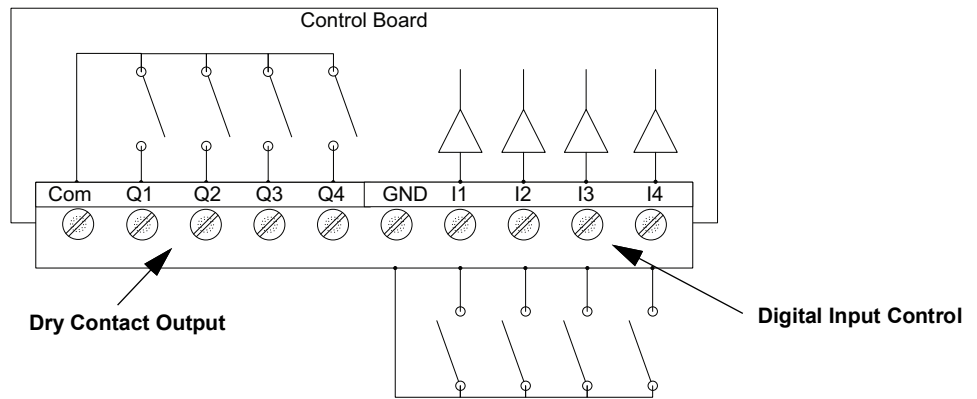

NOTE: The control board J2 accepts wire size between 0.5 and 2.5 mm² (20 and 14 AWG).

Requirement of wire for Dry Contact output			
Wire cross-sectional area (mm²)	Max. length (m)	Min. rated voltage (V AC)	Tightening Torque (Nm)
0.5	31	250	0.5...0.6
1	63		
1.5	94		
2	126		
2.5	157		

Requirement of wire for Digital Input Control			
Wire cross-sectional area (mm²)	Max. length (m)	Min. rated voltage (V AC)	Tightening Torque (Nm)
0.5...2.5	50	250	0.5...0.6

Chapter 4 UL Type 1/IP20 Conversion Kit Assembly (Optional)

This chapter provides information for the UL Type 1/IP20 Conversion Kit Assembly. This kit is available as an option for converting an IP00 unit to an IP2

DANGER

HAZARD OF ELECTRIC SHOCK, EXPLOSION, OR ARC FLASH

- Apply appropriate personal protective equipment (PPE) and follow safe electrical work practices. See NFPA 70E in the USA, CSA Z462, or applicable local standards.
- This equipment must be installed and serviced only by qualified electrical personnel.
- Do not exceed the device's ratings for maximum limits.
- Ground equipment using the ground connecting point provided before turning on any power supplying this device.
- Turn off all power supplying this device and the equipment in which it is installed before working on the device or equipment.
- After removing power, wait for 15 minutes to allow the capacitors to discharge prior to opening the doors or removing covers.
- Always use a properly rated voltage sensing device to confirm power is off.
- Replace all devices, doors, and covers before turning on power to this equipment.
- Carefully inspect the interior for tools left behind before closing and sealing the door.

Failure to follow these instructions will result in death or serious injury.

NOTICE

RISK OF CONTAMINATION BY CONDUCTIVE MATERIAL OR DEBRIS

Thoroughly remove any metal shavings from the unit after any drilling for cable entry access.

Failure to follow this instruction can result in equipment damage.

Any drilling on the wall mount kit should be performed either before attaching it to the chassis or after the chassis and wall mount kit are mounted in the desired location. Make sure that all metal shavings inside of the wall mount kit are removed before energizing.

NOTE: The active filter warranty is void if operational difficulties are found to be caused by metal particles from the installation process.

Prepare the active filter chassis for UL Type 1/IP20 Conversion Kit

1. Remove the access cover by removing the two T20 screws.
2. Retain the screws and discard the access cover.
3. Remove the four T20 screws holding the Remote HMI Connection Assembly.
4. Remove the Remote HMI Connection Assembly, being careful not to damage the wires connected at the back.

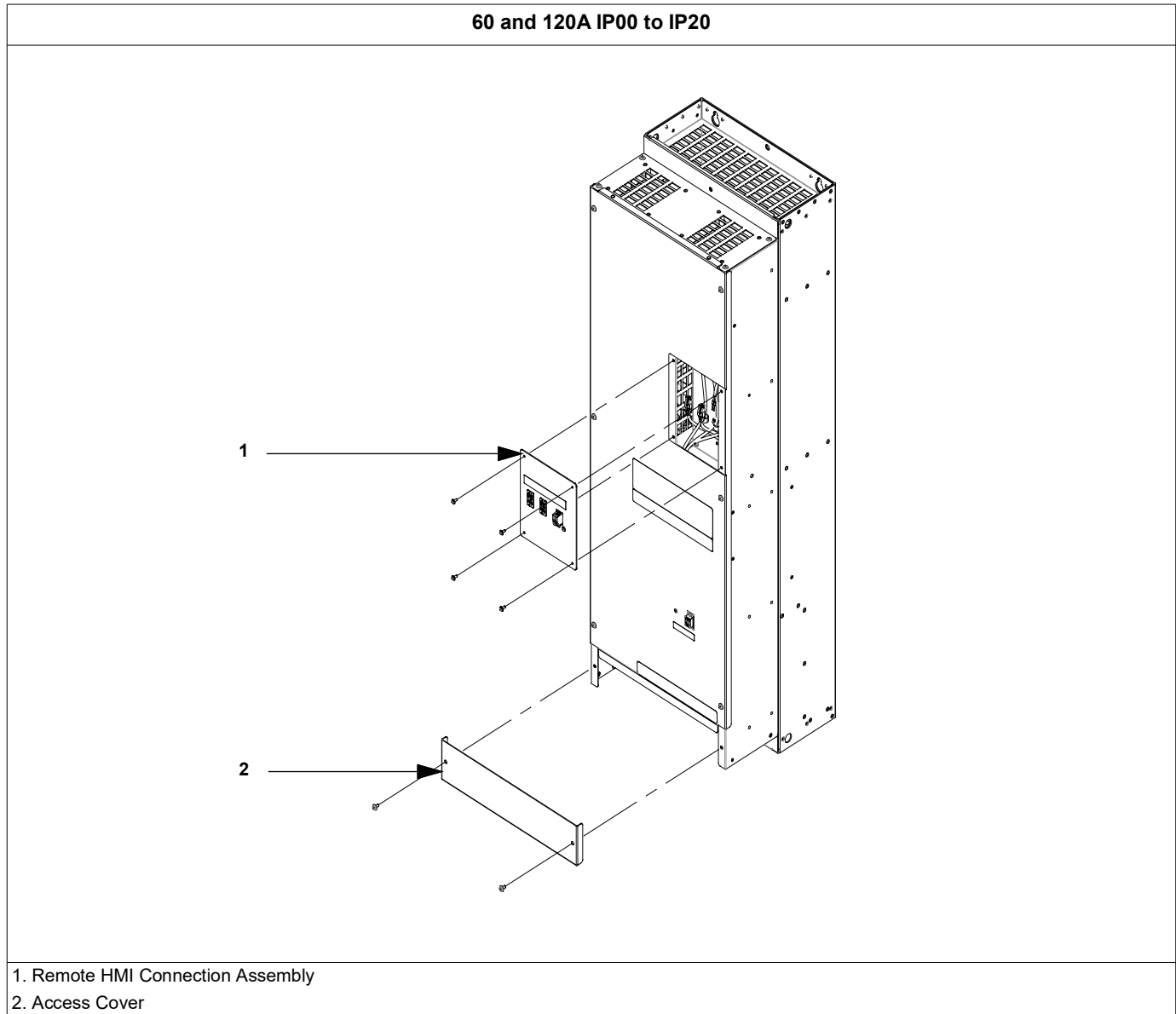

- At the back of the plate, disconnect the two RJ-45 plugs. With a small flat-blade screwdriver, disconnect the red and black power wires.

Back of HMI Blank Plate with Connections

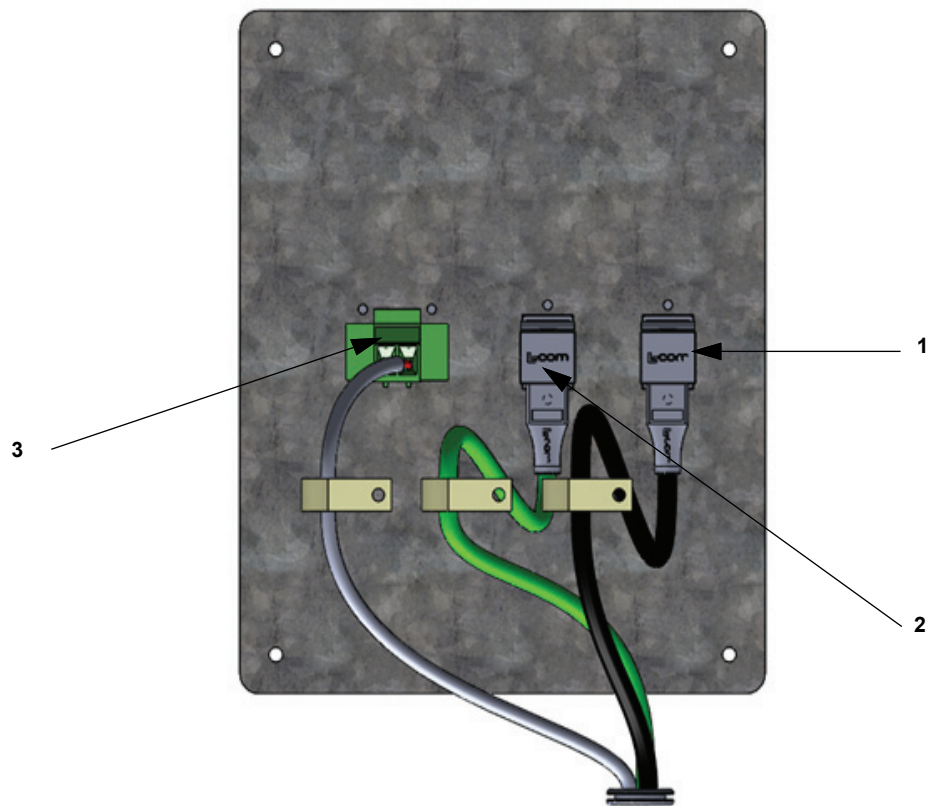

- HMI COM
- Ethernet
- /+ HMI Power

Connect the HMI ground wire to the chassis

1. Remove the green (ground) wire from the hardware bag.
2. Using the provided screw from the hardware bag, connect the ring lug end of the green ground wire to the HMI housing on the chassis.

Back of HMI Blank Plate with Connections

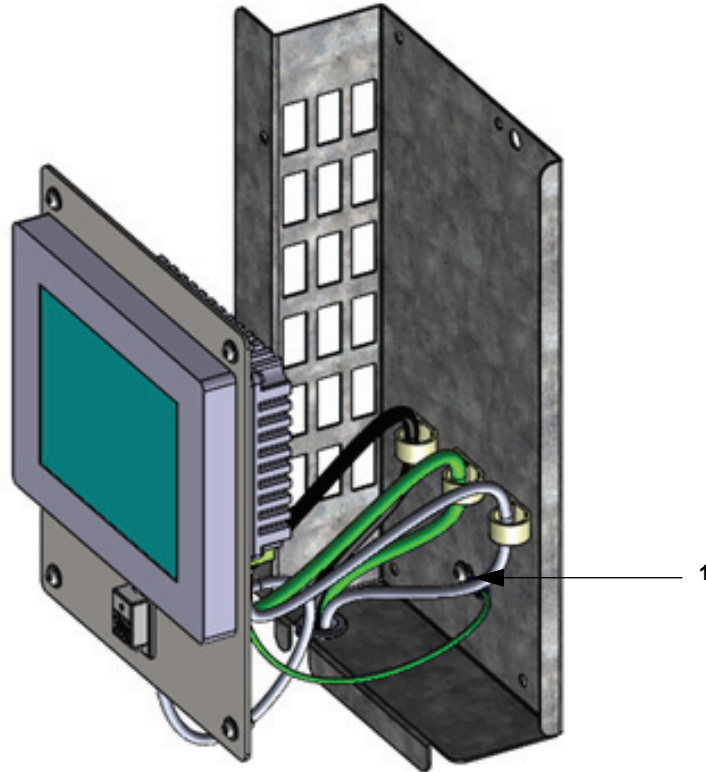

1. HMI Ground Wire Connection. Attach with the provided M4 T20 screw.

Attach the HMI to the HMI mounting plate

The HMI is provided in a box with the chassis. The mounting plate, USB cable, and hardware are provided in the UL Type 1/IP20 Conversion Kit.

1. Remove the Display module by pressing the yellow tab labeled Press to Open.
2. Unplug the HMI back module from the HMI Display module.
3. Remove the plastic nut from the back of the display module
4. Using firm pressure, insert the Tee into the hole provided on the back of the display module.
5. Attach the HMI display module to the HMI mounting plate
6. Re-install the plastic nut onto the display module.
7. Tighten the nut with the tool provided in the HMI box.
8. Plug the HMI back module onto the HMI display module.

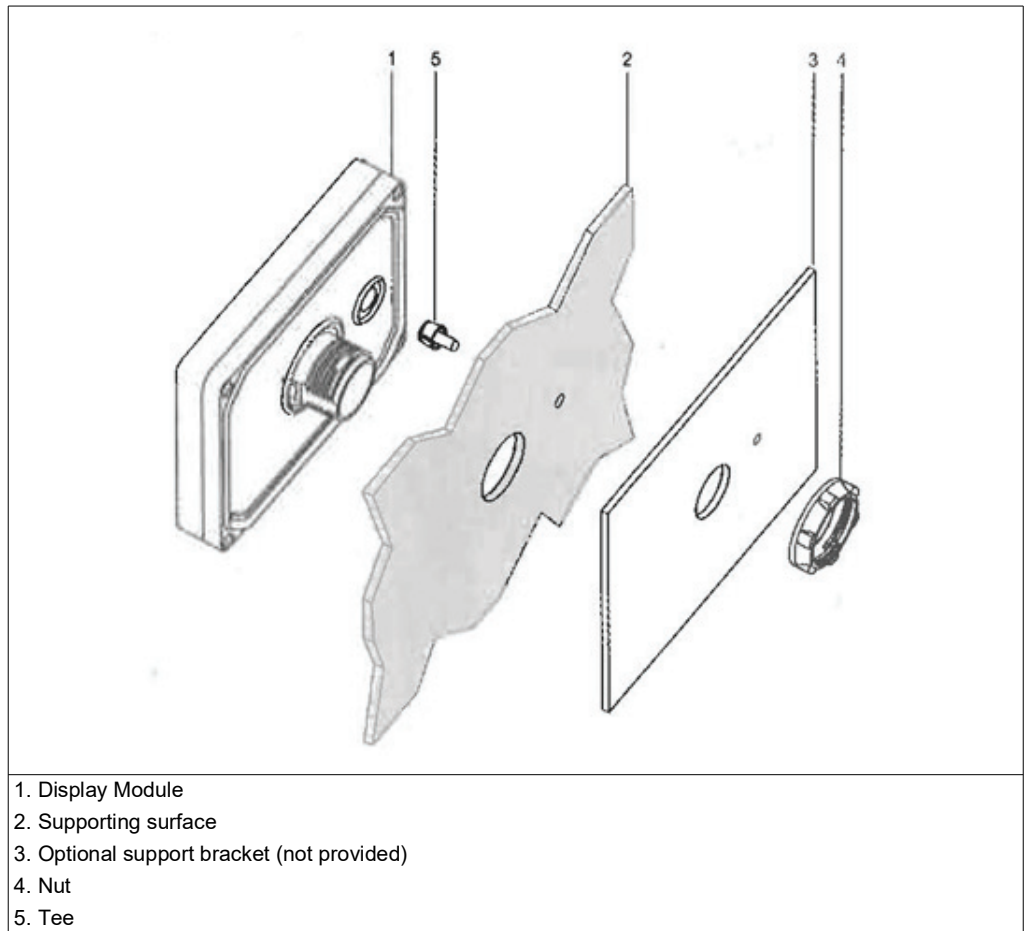

Connect the USB jack to the HMI mounting plate

1. Remove the USB jack and connector from the plastic bag provided in the IP20/UL Type 1 conversion kit.
2. Pass the USB connector through the hole provided through the front of the HMI mounting plate.
3. Connect the HMI jack to the mounting plate using the two T10 screws.
4. Plug the USB connector into the USB jack located at the bottom of the HMI.

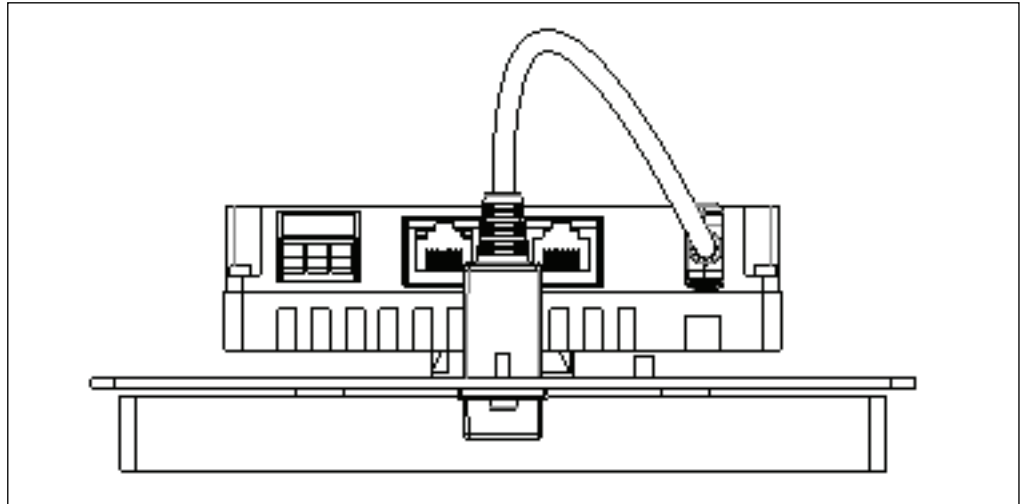

HMI Power wiring

1. Remove the terminal block from the HMI box.
2. Wire the chassis HMI power wiring to the HMI terminal block.
3. Connect the red power wire to the terminal labeled +.
4. Connect the black power wire to the terminal labeled -.
5. Connect the green ground wire to the terminal labeled with the ground symbol.

Installation of the HMI assembly in the Chassis

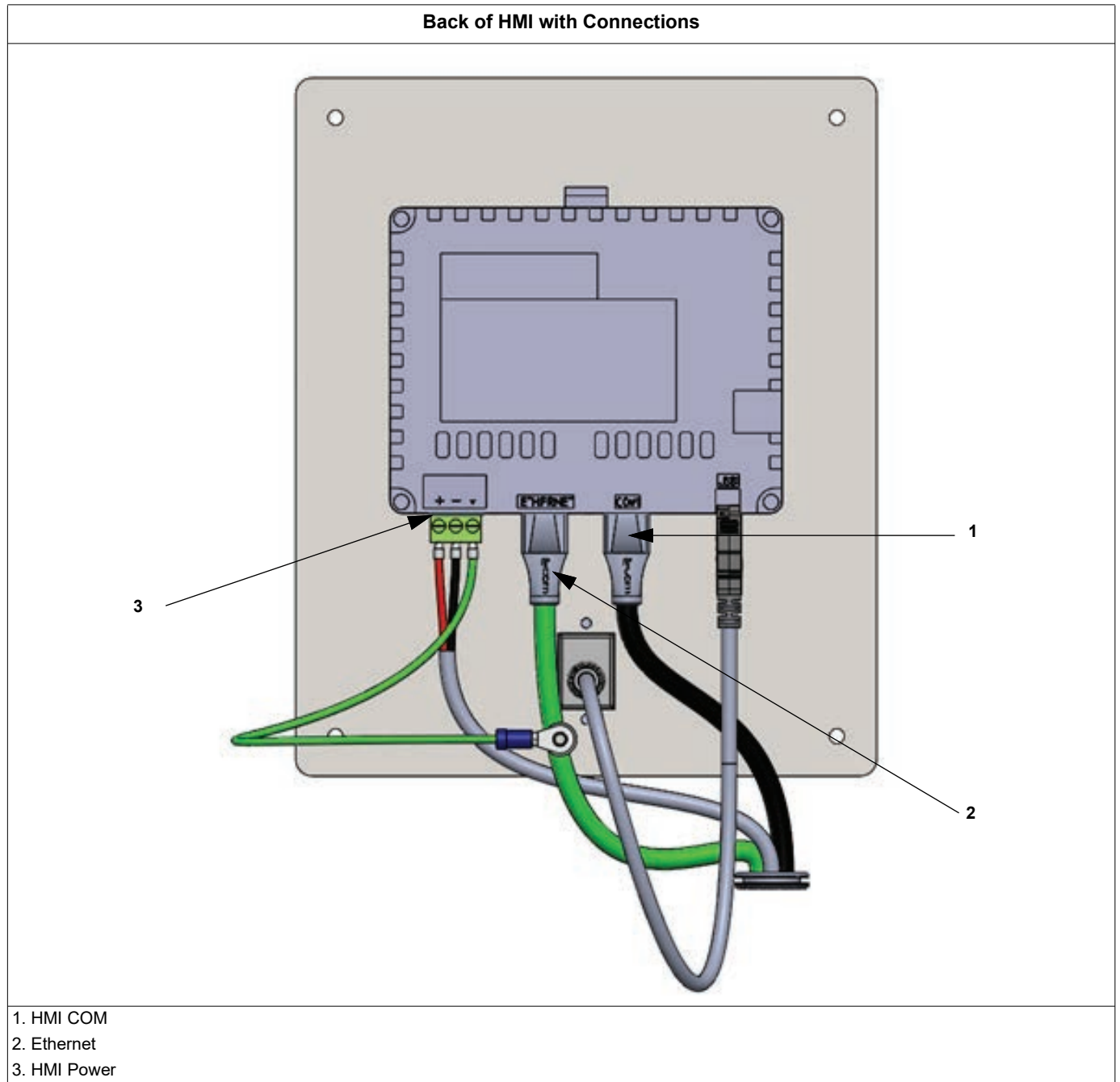

1. Connect the power terminal to the bottom of the HMI.
2. Connect the cable labeled ETHERNET to the ETHERNET jack of the HMI.
3. Connect the cable labeled COM to the COM1 jack of the HMI.
4. Using the four T20 screws, connect the HMI plate to the chassis. Torque to 1.7 N•m (15.05 lb-in).

Attaching the Wall Mount Kit to the Chassis for 60 A and 120 A Units

Wall Mount Kit and HMI Assembly For 60 A and 120 A Units

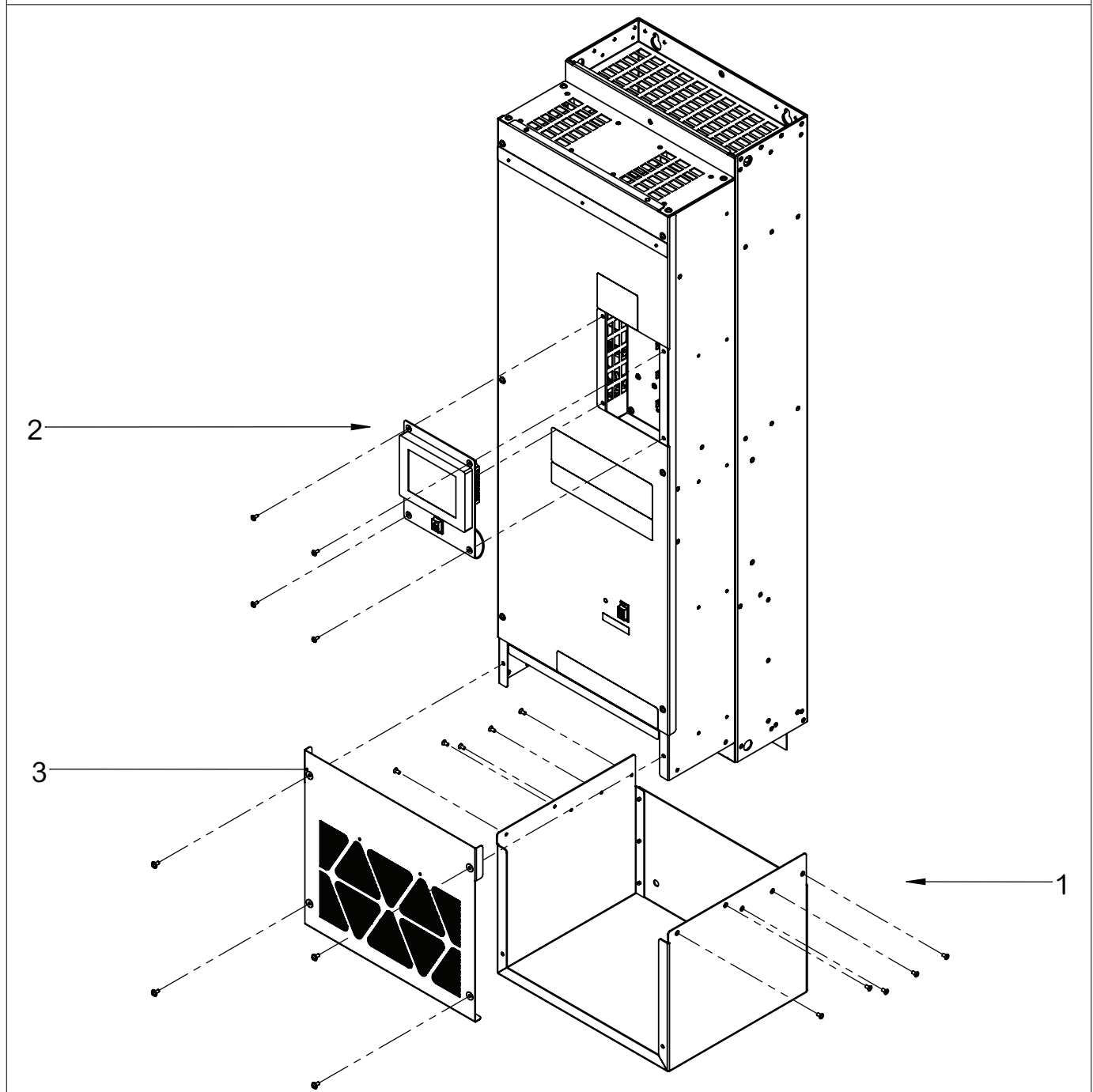

1. Fasten the Wall Mount Kit to the chassis with the provided T25 screws. Torque to 5.7 Nm (50.45 lb-in).
2. Fasten the HMI to the chassis with the provided T20 screws. Torque to 1.7 Nm (15.05 lb-in).
3. Fasten the Wall Mount Kit cover to the Wall Mount Kit with the provided T20 screws. Torque to 3.4 Nm (30.09 lb-in).

Attaching the Wall Mount Kit to the Chassis for 200 A and 300 A Units

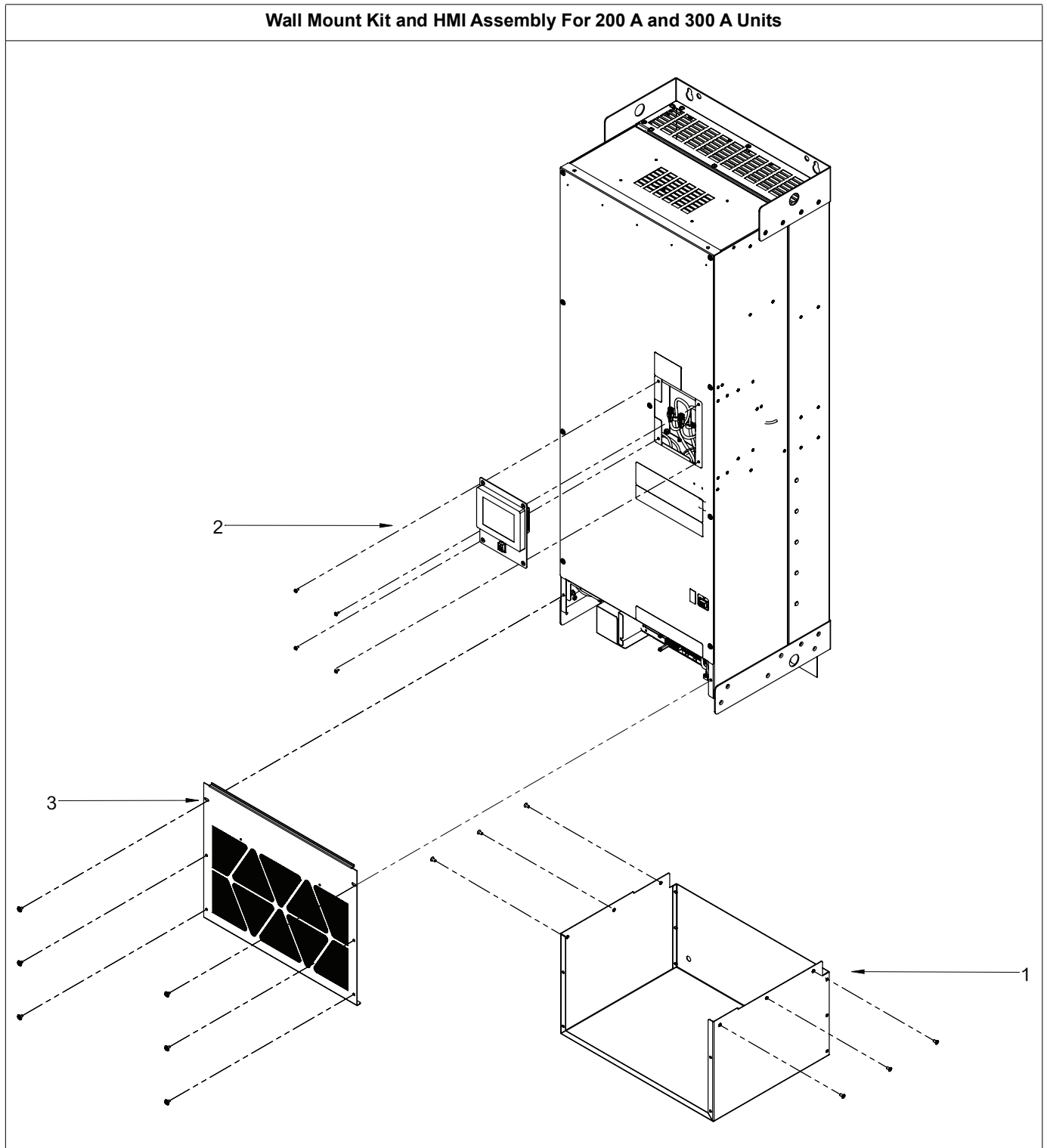

1. Fasten the Wall Mount Kit to the chassis with the provided T25 screws. Torque to 5.7 N•m (50.45 lb-in).
2. Fasten the HMI to the chassis with the provided T20 screws. Torque to 1.7 N•m (15.05 lb-in).
3. Fasten the Wall Mount Kit cover to the Wall Mount Kit with the provided T20 screws. Torque to 3.4 N•m (30.09 lb-in).

Chapter 5 Pre-commissioning

This chapter provides information for preparation of the active filter for commissioning. Before applying power, read and understand this information thoroughly.

Instruments required for commissioning

- Voltmeter or multimeter
- Clamp-on ammeter
- Megohmmeter

Pre-energizing procedure

DANGER

HAZARD OF ELECTRIC SHOCK, EXPLOSION, OR ARC FLASH

- Apply appropriate personal protective equipment (PPE) and follow safe electrical work practices. See NFPA 70E in the USA, CSA Z462, or applicable local standards.
- This equipment must be installed and serviced only by qualified electrical personnel.
- Do not exceed the device's ratings for maximum limits.
- Ground equipment using the ground connecting point provided before turning on any power supplying this device.
- Turn off all power supplying this device and the equipment in which it is installed before working on the device or equipment.
- After removing power, wait for 15 minutes to allow the capacitors to discharge prior to opening the doors or removing covers.
- Always use a properly rated voltage sensing device to confirm power is off.
- Replace all devices, doors, and covers before turning on power to this equipment.
- Carefully inspect the interior for tools left behind before closing and sealing the door.

Failure to follow these instructions will result in death or serious injury.

Installation Inspection

Inspect all connections for both power and control wiring. Make sure that the correct termination points have been made for each wire. Make sure that all connections are firmly tightened prior to start-up.

Pre-Commissioning Checklist

Prior to commissioning the active filter system, make sure that the following steps are completed:

- Electrical connections is made in accordance with local codes.
- Main CTs are installed to measure the current of the system to be corrected.
- The secondary wiring of the main CTs is connected to the CT board of the active filter.
- If it is a parallel active filter system, CT wiring and parallel communications wiring is installed between the CT boards of each unit.
- All drives, harmonic generating loads, downstream of the main CTs must have the recommended minimum 3% line reactor or DC choke installed (required for optimum performance when harmonic mode is intended).
- There are no un-isolated capacitors, such as power factor correction capacitors downstream of the main CTs. (required when harmonic mode is intended to operate).
- To fully test the system integration, all loads supported by the active filter system should be available for operation. The total output current required for the system must be at least 10% of the unit's nameplate rating. For example, a 300 A unit will need a minimum of 30 A Total Output current.
- If backup generation is connected to the active filter, the system should also be tested with the generator supporting the connected loads.

The Field Service Engineer will need to know the following information to commission the active filter:

- Installation location of the main CTs in relationship to the active filter (load or grid, parallel systems must have the main CTs installed on the source side of the active filter system).
- The ratio of the main CTs installed.
- The phase on which each CT is installed.
- Intended mode of operation (Harmonic, Power Factor, Load Balancing).
- Make sure firmware version is the latest version as shown on se.com PCSP range page-Software and Firmware section <https://www.se.com/us/en/productrange/63426-powerlogic-accusine-pcs+/#software-and-firmware>.

Commissioning procedures

For commissioning procedures, refer to the user manual available on the Schneider Electric website.

Chapter 6 IT, HRG, and Corner Grounded Systems

This chapter provides information on using the active filter with Isolated Terra (IT), High Resistance Ground (HRG), and corner grounded systems.

DANGER

HAZARD OF ELECTRIC SHOCK, EXPLOSION, OR ARC FLASH

- Apply appropriate personal protective equipment (PPE) and follow safe electrical work practices. See NFPA 70E in the USA, CSA Z462, or applicable local standards.
- This equipment must be installed and serviced only by qualified electrical personnel.
- Do not exceed the device's ratings for maximum limits.
- Ground equipment using the ground connecting point provided before turning on any power supplying this device.
- Turn off all power supplying this device and the equipment in which it is installed before working on the device or equipment.
- After removing power, wait for 15 minutes to allow the capacitors to discharge prior to opening the doors or removing covers.
- Always use a properly rated voltage sensing device to confirm power is off.
- Replace all devices, doors, and covers before turning on power to this equipment.
- Carefully inspect the interior for tools left behind before closing and sealing the door.

Failure to follow these instructions will result in death or serious injury.

NOTICE

HAZARD OF EQUIPMENT DAMAGE

Open the IT/BP switches before operating the unit on an IT, HRG, or corner grounded system.

Failure to follow these instructions can result in equipment damage.

When connecting the active filter to an IT, HRG, or corner grounded system, open the IT/BP switches as follows:

1. Remove the large main cover of the unit.

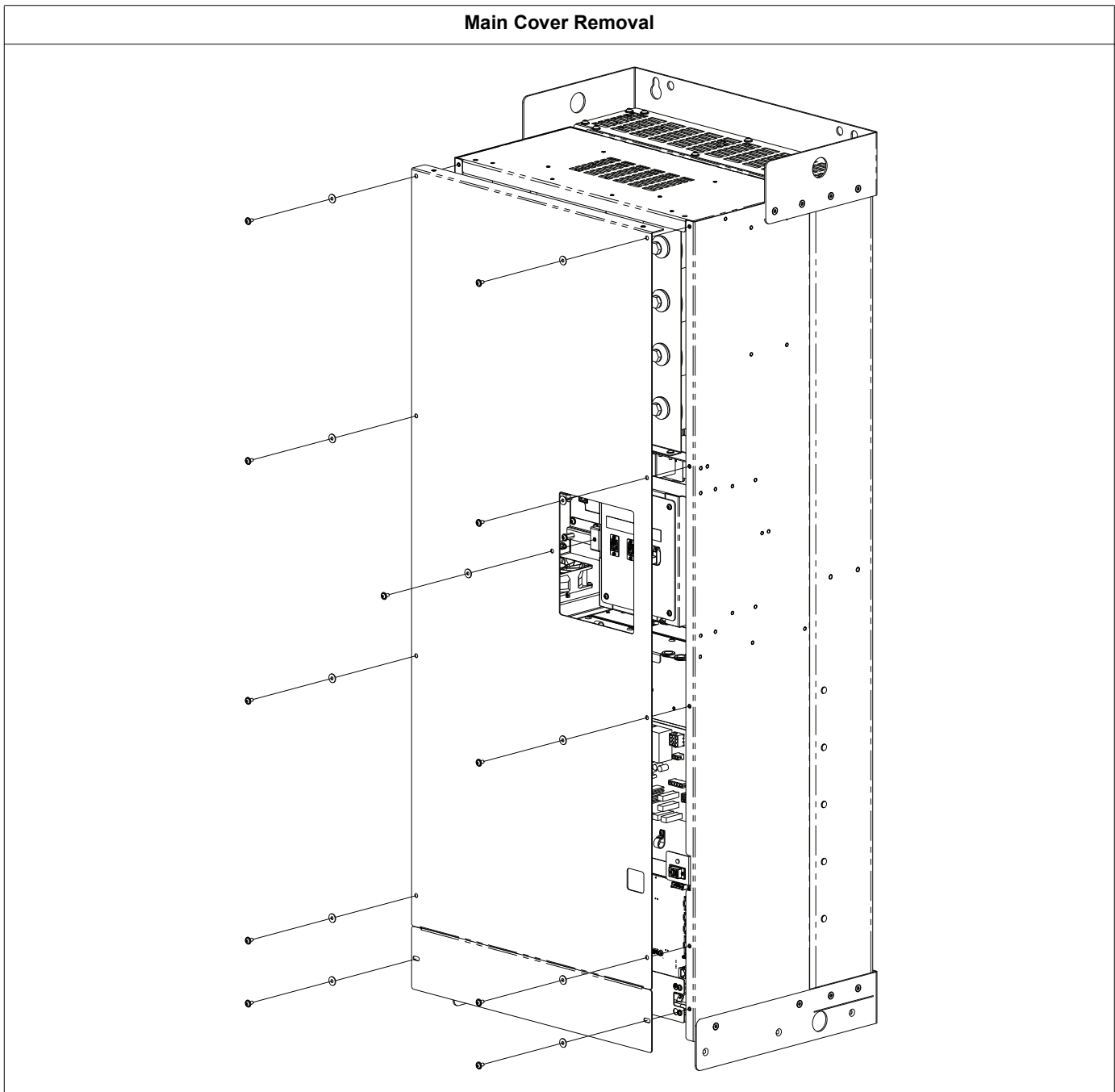

2. Locate the IT/BP switches.

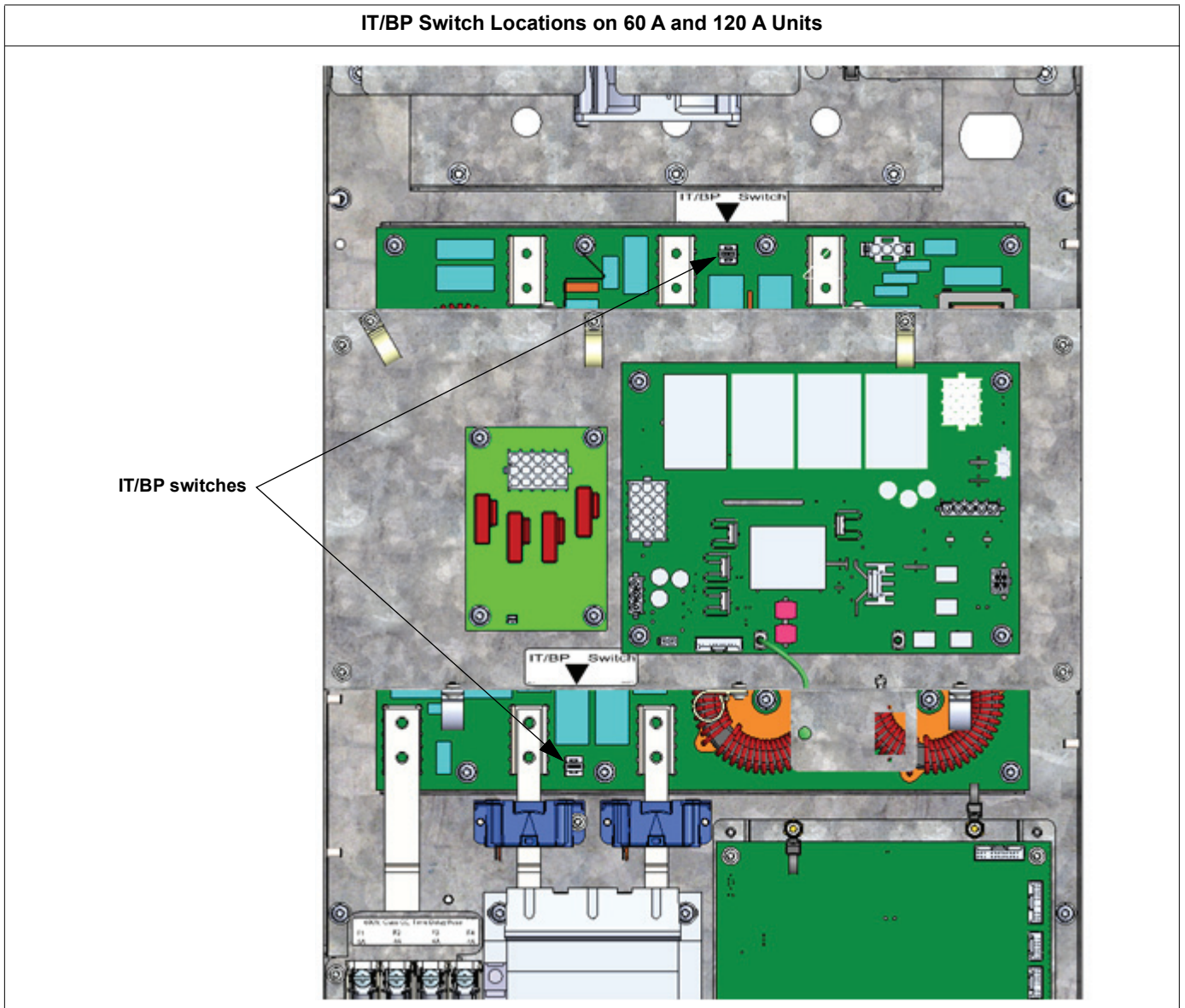

IT/BP Switch Locations on 200 A and 300 A Units

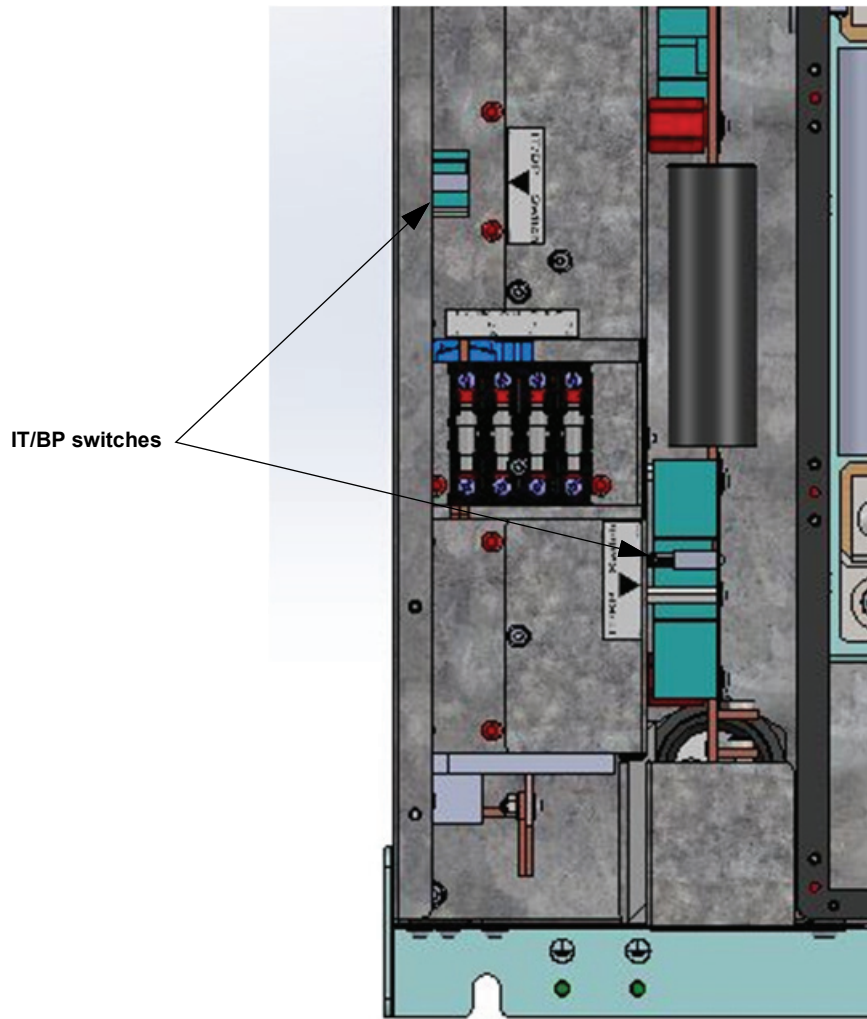

3. Pull the plunger out.

The switch is open when the plunger is completely out as shown here.

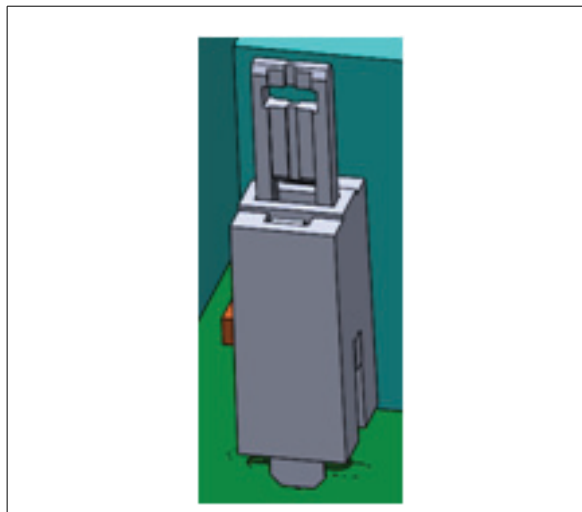

Chapter 7 IP00 chassis in a customer supplied enclosure

An IP00 chassis can be installed in other types of enclosures to provide a greater degree of environmental protection.

DANGER

HAZARD OF ELECTRIC SHOCK, EXPLOSION, OR ARC FLASH

- Apply appropriate personal protective equipment (PPE) and follow safe electrical work practices. See NFPA 70E in the USA, CSA Z462, or applicable local standards.
- This equipment must be installed and serviced only by qualified electrical personnel.
- Do not exceed the device's ratings for maximum limits.
- Ground equipment using the ground connecting point provided before turning on any power supplying this device.
- Turn off all power supplying this device and the equipment in which it is installed before working on the device or equipment.
- After removing power, wait for 15 minutes to allow the capacitors to discharge prior to opening the doors or removing covers.
- Always use a properly rated voltage sensing device to confirm power is off.
- Replace all devices, doors, and covers before turning on power to this equipment.
- Carefully inspect the interior for tools left behind before closing and sealing the door.

Failure to follow these instructions will result in death or serious injury.

The active filter consists of two sections, a power section and a control section.

The power section dissipates a significant amount of power, which must be evacuated to the outside of the enclosure. It is isolated by IP54 protections from the control section within the chassis. The chassis has a cooling fan to provide adequate airflow. Air inlets, outlets, and ductwork must be provided in the enclosure with the appropriate degree of protection required. The airflow must be at least equal to the values in the following table based on the amperage of the active filter.

Active Filter	Airflow Required m ³ /h (ft ³ /min)	Power Section Dissipation
60 A	370 (217.7)	1.04 kW
120 A	830 (488.3)	2.48 kW
200 A	1900 (1117.8)	4.92 kW
300 A	1900 (1117.8)	6.54 kW

The control section also has a fan for its cooling needs. It requires 200 m³/h (117.7 ft³/min) of air meeting Pollution Degree 2, i.e., does not contain conductive particles, significant amounts of dust or corrosive or otherwise harmful gases.

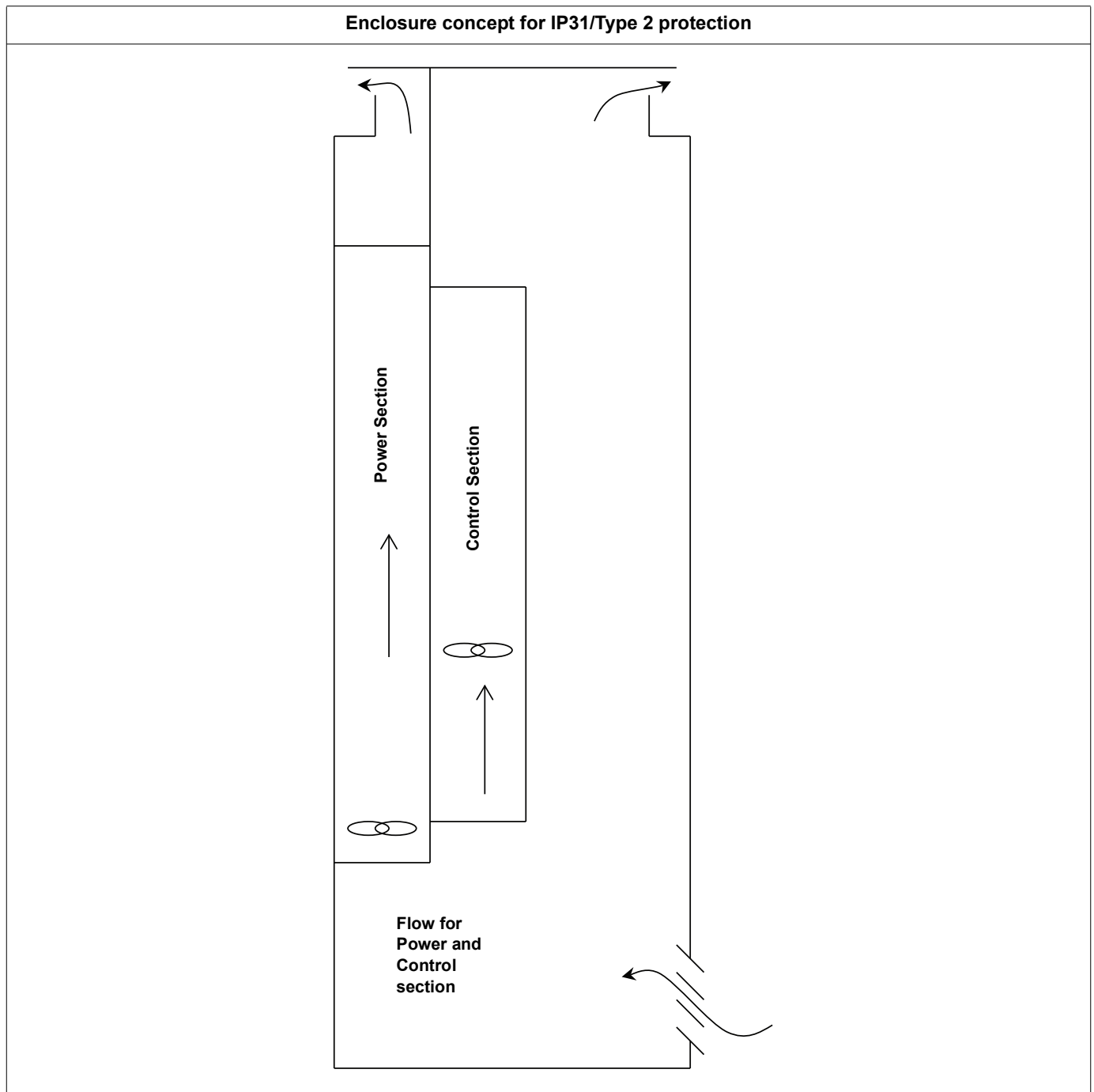

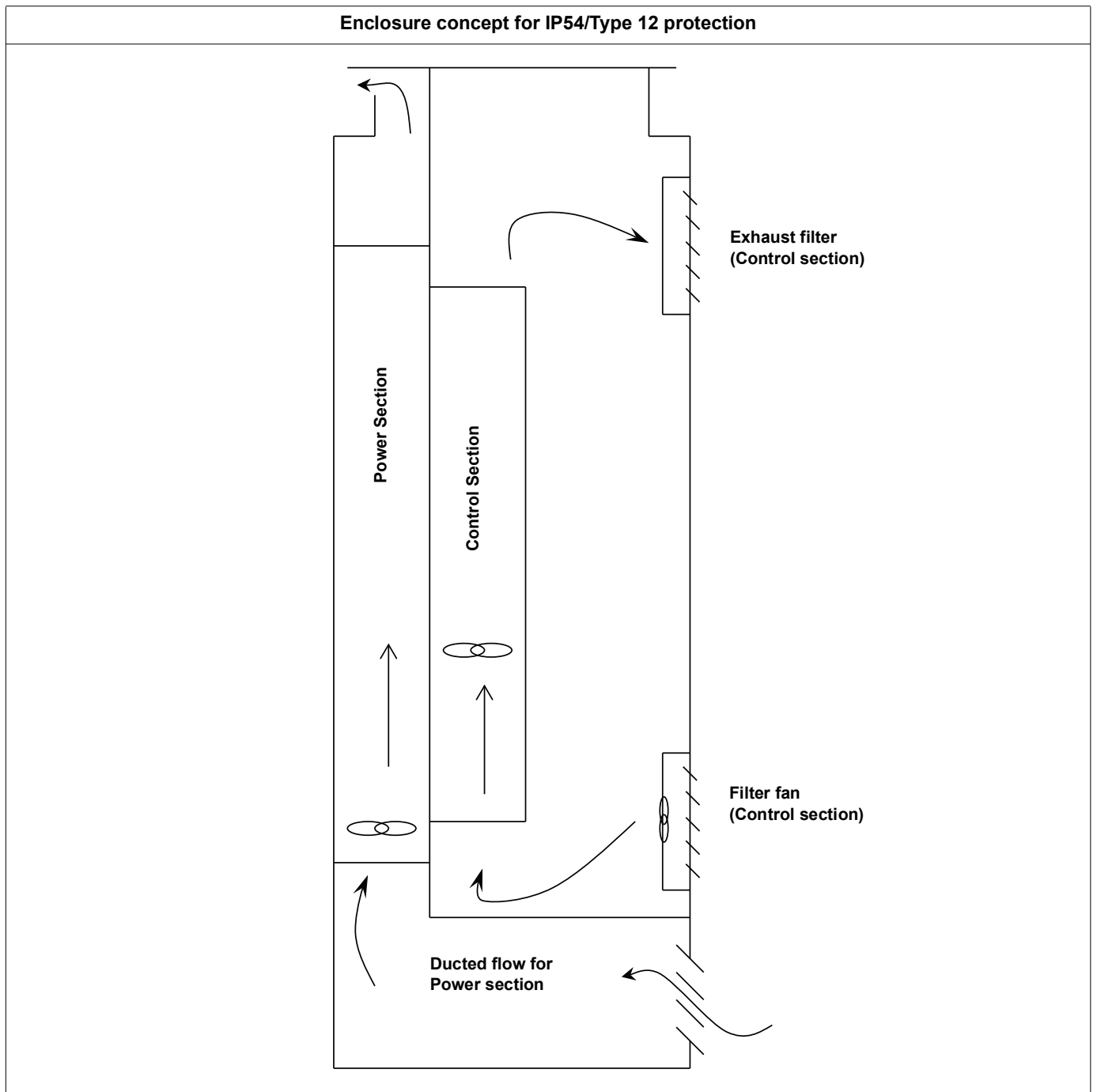

If the hot air exiting the filter is not ducted and evacuated to the outside, it can be recirculated back in, causing ineffective ventilation. To avoid this and help ensure serviceability, leave enough free space around the chassis as indicated in the following table and illustration.

Active Filter	Exhaust Free Space h1 mm (inches)	Inlet Free Space h2 mm (inches)
60 A	182 (7.17)	220 (8.66)
120 A	217 (8.54)	220 (8.66)
200 A	200 (7.87)	220 (8.66)
300 A	200 (7.87)	220 (8.66)

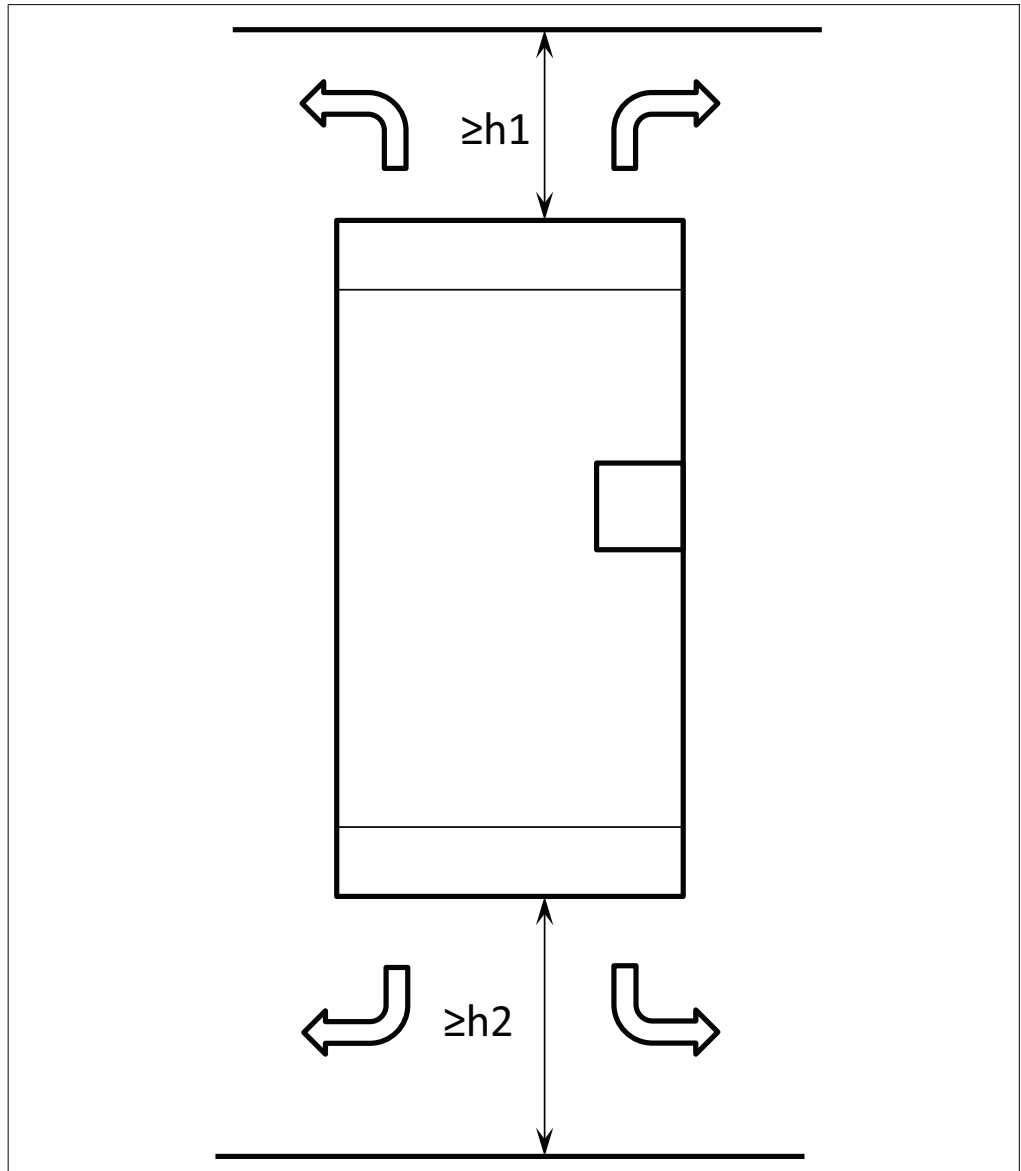

HMI Connections

When making the HMI connections, make sure it is mounted in a location that is accessible for users. HMI mounting instructions are provided in the box containing the HMI and interconnection wiring.

24 volt power

Make the 24 volt power connection as follows:

1. Connect the HMI power cable, which has a green connector on one end and a black connector on the other end.
 - Connect the green connector to the chassis green connector labeled PWR.
 - Connect the black connector to the HMI labeled DC24V.
2. Provide a ground wire from the HMI ground connection to the enclosure/chassis ground. The ground wire size must be between 0.2 to 1.5 mm² (24 - 16 AWG) with a temperature rating of 75 °C (167 °F).

Ethernet

Connect the green CAT5 cable labeled ETH to the active filter front connection labeled ETH.

Communication

Connect the black CAT5 cable labeled COM to the active filter front connection labeled COM. Connect the other end to the RJ45 connector on the HMI labeled COM1.

Enclosure mount USB

Provide a female USB that can be accessed by the user. Use a panel mount type A female to standard type A male. Connect the standard type A male to the USB A jack on the back of the HMI. Ensure that the panel mount type A female end is accessible to the end user. Use a USB cable that meets the requirement for the type of enclosure utilized.

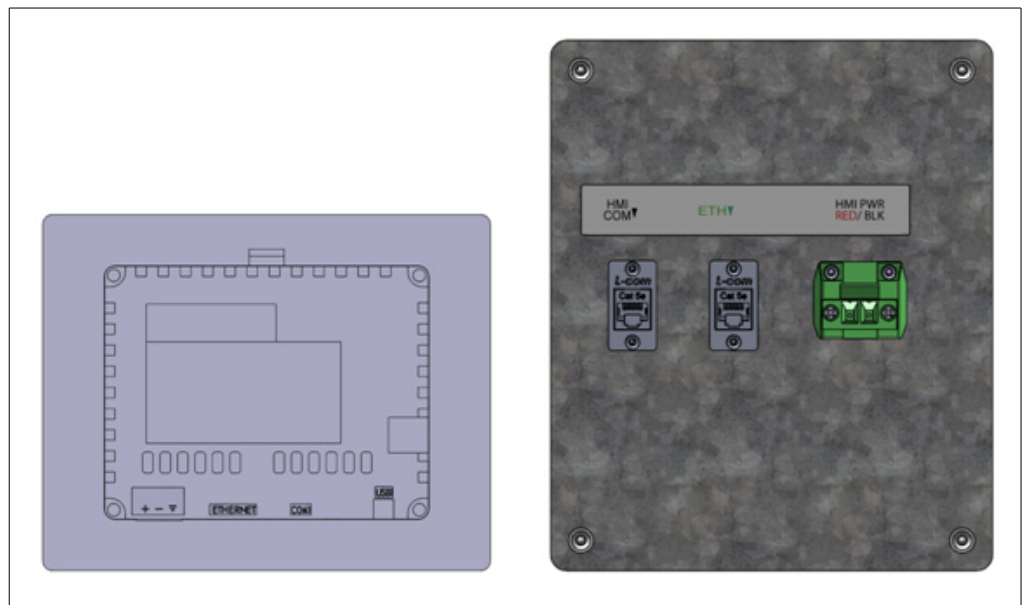

Dimensional Drawings

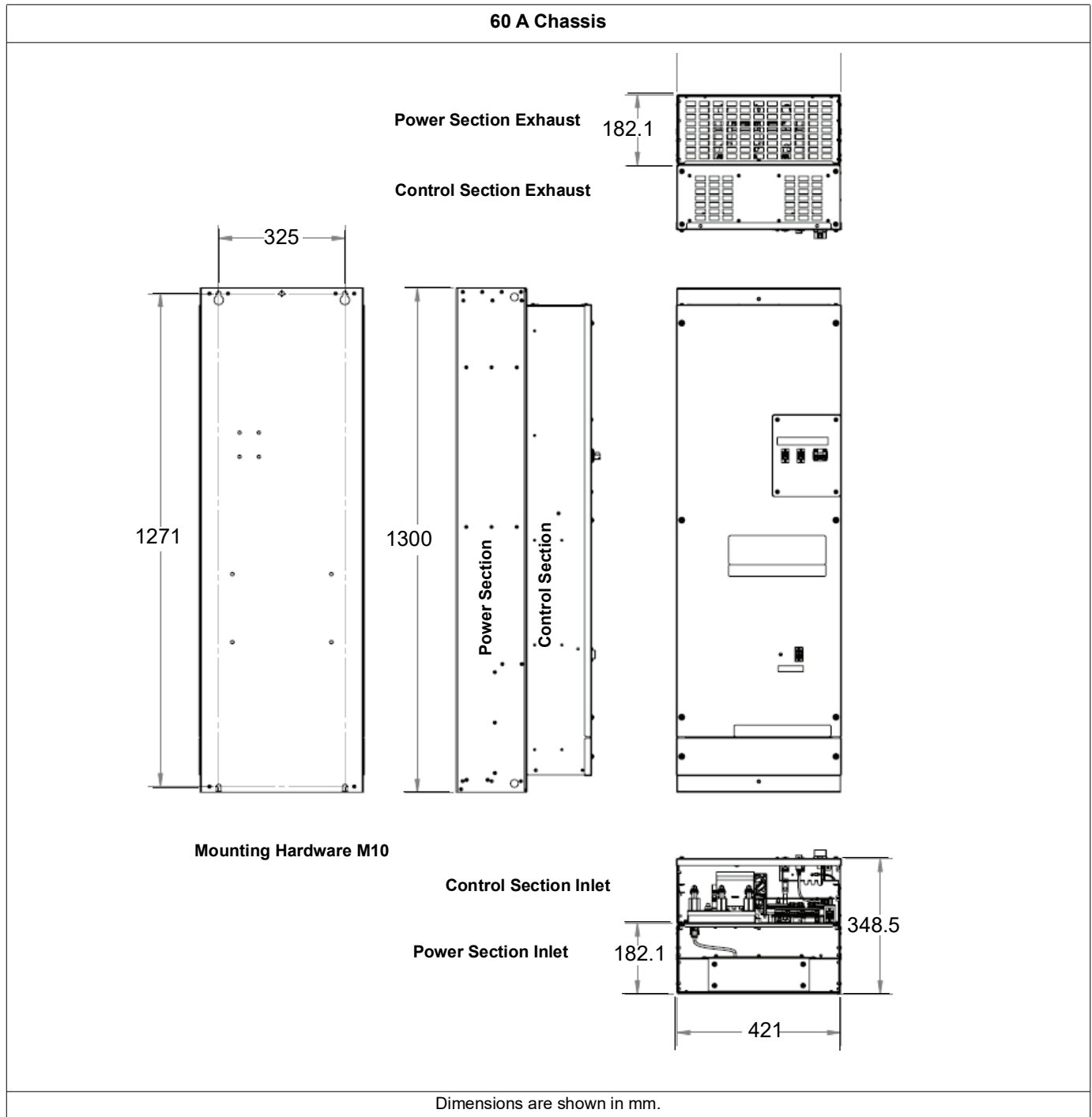

120 A Chassis

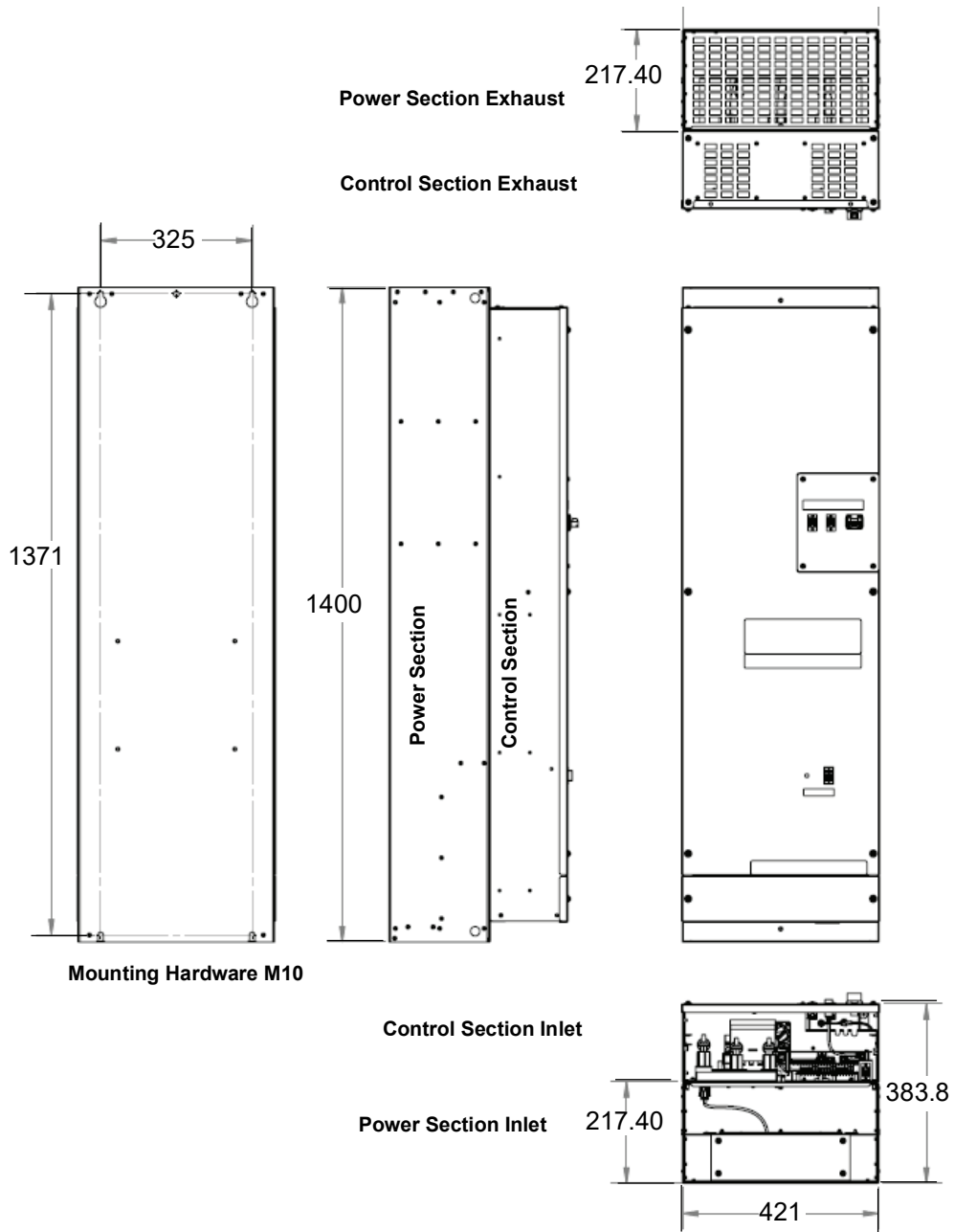

Dimensions are shown in mm.

200 A and 300 A Power Section Duct Dimensions

567 x 149.5 Rectangular Exhaust Duct

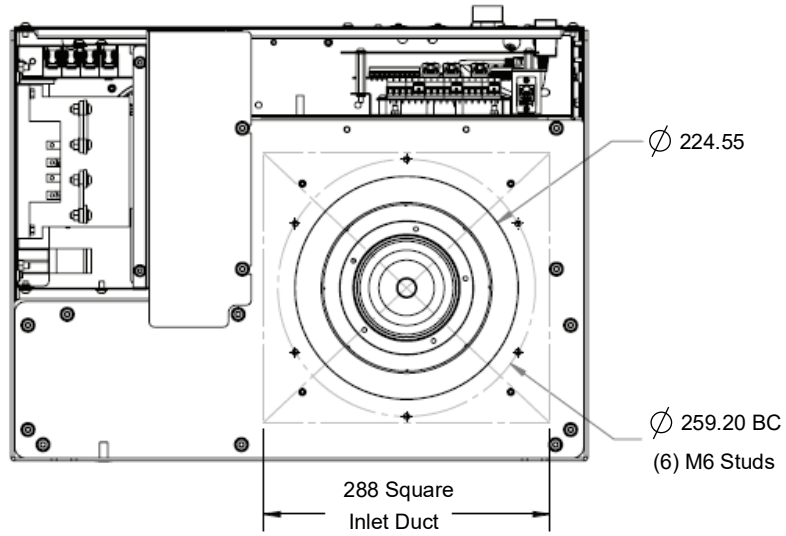
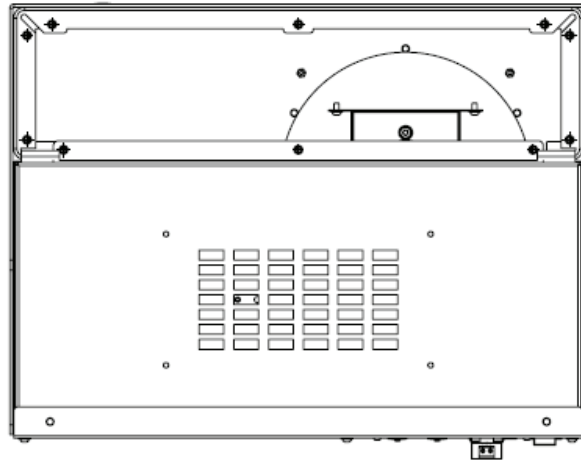

Dimensions are shown in mm.

Dimensions of 200 A and 300 A Exhaust Duct Flange

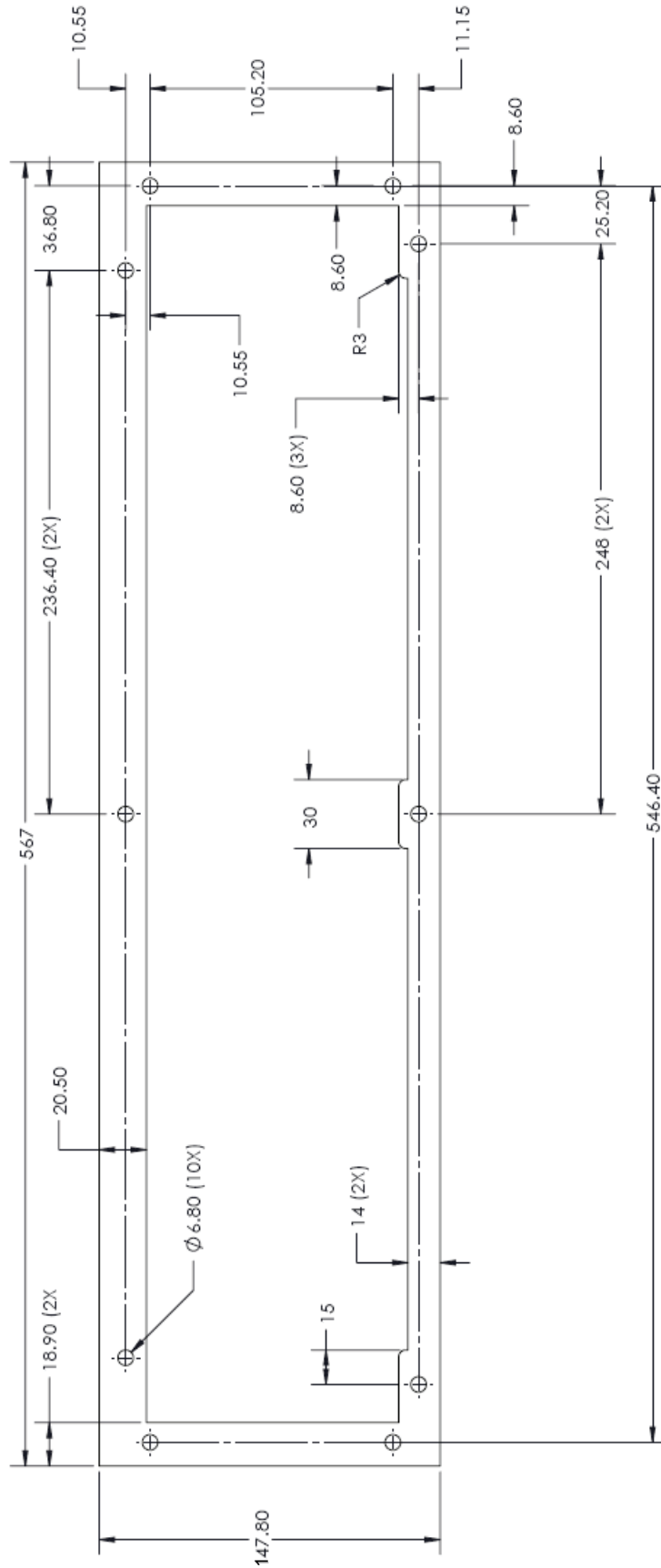

Dimensions are shown in mm.

Dimensions of 200 A and 300 A Inlet Duct Flange

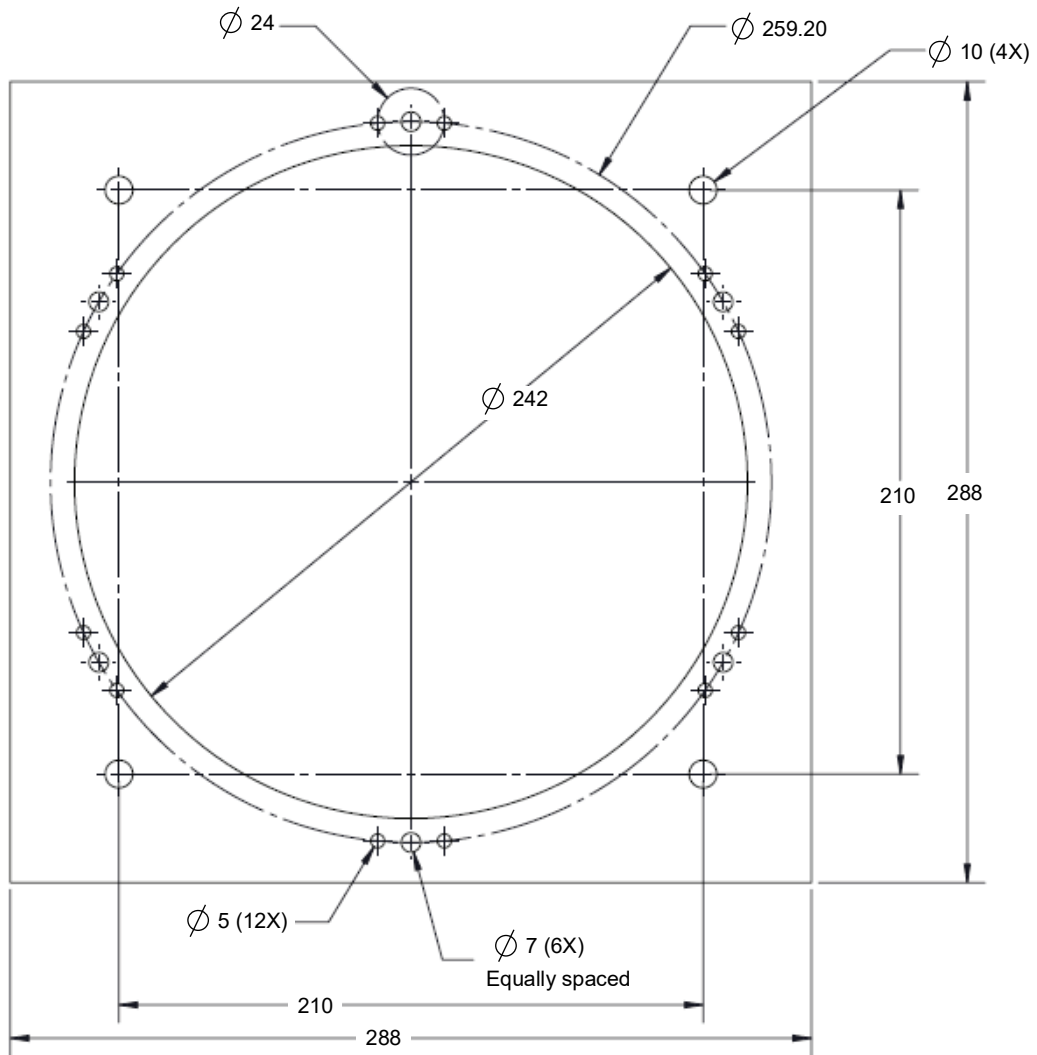

Dimensions are shown in mm.



Schneider Electric

35 rue Joseph Monier
92500 Rueil Malmaison - France
Phone: +33 (0) 1 41 29 70 00
www.se.com

© 2024 Schneider Electric. All Rights Reserved.

NHA41798-03 11/2024



Schneider Electric

Stafford Park 5
Telford, TF3 3BL
United Kingdom

Importado en México por:

Schneider Electric México, S.A. de C.V.

Calz. Javier Rojo Gómez 1121-A

Col. Gpe. del Moral 09300 México, D.F.

Tel. 5804-5000

www.se.com.mx

Schneider Electric, AccuSine, PowerLogic, and Modbus are either trademarks or registered trademarks of Schneider Electric in France, the USA and other countries. Other trademarks used are the property of their respective owners.