

# Schneider Charge Pro

## Modbus

### Connectivity Guide

NAT3046700-02  
09/2025



# Legal Information

The information provided in this document contains general descriptions, technical characteristics and/or recommendations related to products/solutions.

This document is not intended as a substitute for a detailed study or operational and site-specific development or schematic plan. It is not to be used for determining suitability or reliability of the products/solutions for specific user applications. It is the duty of any such user to perform or have any professional expert of its choice (integrator, specifier or the like) perform the appropriate and comprehensive risk analysis, evaluation and testing of the products/solutions with respect to the relevant specific application or use thereof.

The Schneider Electric brand and any trademarks of Schneider Electric SE and its subsidiaries referred to in this document are the property of Schneider Electric SE or its subsidiaries. All other brands may be trademarks of their respective owner.

This document and its content are protected under applicable copyright laws and provided for informative use only. No part of this document may be reproduced or transmitted in any form or by any means (electronic, mechanical, photocopying, recording, or otherwise), for any purpose, without the prior written permission of Schneider Electric.

Schneider Electric does not grant any right or license for commercial use of the document or its content, except for a non-exclusive and personal license to consult it on an "as is" basis.

Schneider Electric reserves the right to make changes or updates with respect to or in the content of this document or the format thereof, at any time without notice.

**To the extent permitted by applicable law, no responsibility or liability is assumed by Schneider Electric and its subsidiaries for any errors or omissions in the informational content of this document, as well as any non-intended use or misuse of the content thereof.**

Electrical equipment should be installed, operated, serviced, and maintained only by qualified personnel. No responsibility is assumed by Schneider Electric for any consequences arising out of the use of this material.

---

# Table of Contents

Safety Information .....	4
About the Book .....	5
Safety Precautions .....	6
Product Family .....	7
Supported Commands .....	8
Connectivity with PowerTag Energy Resi9 .....	8
Connectivity with P1 Smart meter .....	13

# Safety Information

## Important Information

Read these instructions carefully and look at the equipment to become familiar with the device before trying to install, operate, service, or maintain it. The following special messages may appear throughout this documentation or on the equipment to warn of potential hazards or to call attention to information that clarifies or simplifies a procedure.



The addition of this symbol to a "Danger" or "Warning" safety label indicates that an electrical hazard exists which will result in personal injury if the instructions are not followed.



This is the safety alert symbol. It is used to alert you to potential personal injury hazards. Obey all safety messages that follow this symbol to avoid possible injury or death.

### **DANGER**

**DANGER** indicates a hazardous situation which, if not avoided, **will result in** death or serious injury.

### **WARNING**

**WARNING** indicates a hazardous situation which, if not avoided, **could result in** death or serious injury.

### **CAUTION**

**CAUTION** indicates a hazardous situation which, if not avoided, **could result in** minor or moderate injury.

### **NOTICE**

**NOTICE** is used to address practices not related to physical injury.

## Please Note

Electrical equipment should be installed, operated, serviced, and maintained only by qualified personnel. No responsibility is assumed by Schneider Electric for any consequences arising out of the use of this material.

A qualified person is one who has skills and knowledge related to the construction and operation of electrical equipment and its installation, and has received safety training to recognize and avoid the hazards involved.

# About the Book

## Purpose of this Document

The purpose of this document is to guide you with the connectivity of Schneider Charge Pro system communicating through Modbus RTU with external meter (PowerTag Energy Resi9 and P1 smart meter).

## Document Version History

Document Reference–Revision	Release Date	Evolution
NAT3046700-00	April 2025	Document creation
NAT3046700-01	June 2025	Updates with new features
NAT3046700-02	September 2025	Updates with new features

## Terminology

Anacronym	Designation
EVSE	Electrical Vehicle Supply Equipment (charging station compliant with OCPP standard)
EVCE	Electrical Vehicle Charging Expert
OCPP	Open Charge Point Protocol (communication protocol used between the charging stations and a central system)

## Related Documents

Document Title	Document Reference–Revision	Author	Release Date	Link
Schneider Charge Pro Installation Guide	BRU2882901	Schneider Electric	11/2024	<a href="https://www.se.com/ww/en/download/document/BRU2882901/">https://www.se.com/ww/en/download/document/BRU2882901/</a>
Schneider Charge Pro Commissioning Guide	BRU9949500	Schneider Electric	01/2025	<a href="https://www.se.com/ww/en/download/document/BRU9949500/">https://www.se.com/ww/en/download/document/BRU9949500/</a>
Schneider Charge Pro OCPP Guide	BRU5587800	Schneider Electric	11/2024	<a href="https://www.se.com/ww/en/download/document/BRU5587800/">https://www.se.com/ww/en/download/document/BRU5587800/</a>

# Safety Precautions

Installation, wiring, testing, and maintenance must be performed in accordance with all local and national electrical codes.

Read carefully and follow the safety precautions below:

## DANGER

### HAZARD OF ELECTRIC SHOCK, EXPLOSION, OR ARC FLASH

Safe electrical installation must be carried out only by skilled professionals. Skilled professionals must prove profound knowledge in the following areas:

- Connecting to installation networks.
- Connecting several electrical devices.
- Laying electrical cables.
- Safety standards, local wiring rules and regulations.

**Failure to follow these instructions will result in death or serious injury.**

## NOTICE

### UNINTENTIONAL OPERATION

- PowerTag Energy Resi9 load management feature shall be enabled by eSetup commissioning before use.
- The P1 smart meter load management feature shall be enable by eSetup commissioning before use.
- When installing the CT on the cable, pay attention to the correct direction of the phase in relation to the source. Wrong direction generates negative outputs (negative energy).

**Failure to follow these instructions will result in malfunction.**

# Product Family

There are eight types of charging stations:

- Charging stations with a T2S socket
- Charging stations with an attached cable
- Charging stations with a T2S socket and a MID meter
- Charging stations with an attached cable and a MID meter
- Charging stations with a T2S socket and a cellular modem
- Charging stations with an attached cable and a cellular modem
- Charging stations with a T2S socket, a MID meter and cellular modem
- Charging stations with an attached cable a MID meter and cellular modem



# Connectivity with PowerTag Energy Resi9

## Introduction

The function of PowerTag Energy Resi9 + Charge Pro is to implement load management.

To enable this feature, you need to conduct commissioning through eSetup.

Please refer to Schneider Charge Pro Commissioning Guide *BRU9949500* for more details.

## PowerTag Energy Resi9 Product Information

Energy sensor, PowerTag Resi9 80A 6 circuits LN Modbus(R9M80X6M)

Energy sensor, PowerTag Resi9 universal 80 A, 160 A, 250 A 6 circuits Modbus(R9MUX6M)

The Energy sensor, PowerTag Energy Resi9 (hereinafter referred to as module) measures current, voltage, energy consumption, etc., for monitoring.

This energy sensor provides bi-directional active energy. The active energy is saved in the non-volatile memory of the energy sensor.

The energy sensor provides highly accurate measurement and average value.

To be completed with Resi9 Current Transformer.



R9M80X6M



R9MUX6M

Scan this QR code or the one on the front face of the module to access Go2SE and choose your language for complete information about the device, including operation, configuration and using the product.



R9M80X6M



R9MUX6M

Resi9 Current Transformer 80 A (R9MCT80), 160 A (R9MCT160), 250 A (R9MCT250)

The Resi9 Current Transformer (hereafter referred to as CT) is the actual sensing device. One set has 6 units or 3 units. The set needs to be procured separately. Select the suitable CT with a rating not less than the home installation's current rating.



R9MCT80



R9MCT160



R9MCT250

# NOTICE

## UNINTENTIONAL OPERATION

- PowerTag Resi9 should not be applied in any power grid without neutral line.
- 1-Phase of PowerTag Resi9 should not be applied in any power grid of 3-Phase.
- The phase line where CT ring is installed should be the same as the phase line of the charging station.
- End point of CT ring should always connect to I1+ and I1- of PowerTag Resi9.

**Failure to follow these instructions will result in malfunction.**

## Tools Supplied by User



## Wiring Diagram of R9M80X6M

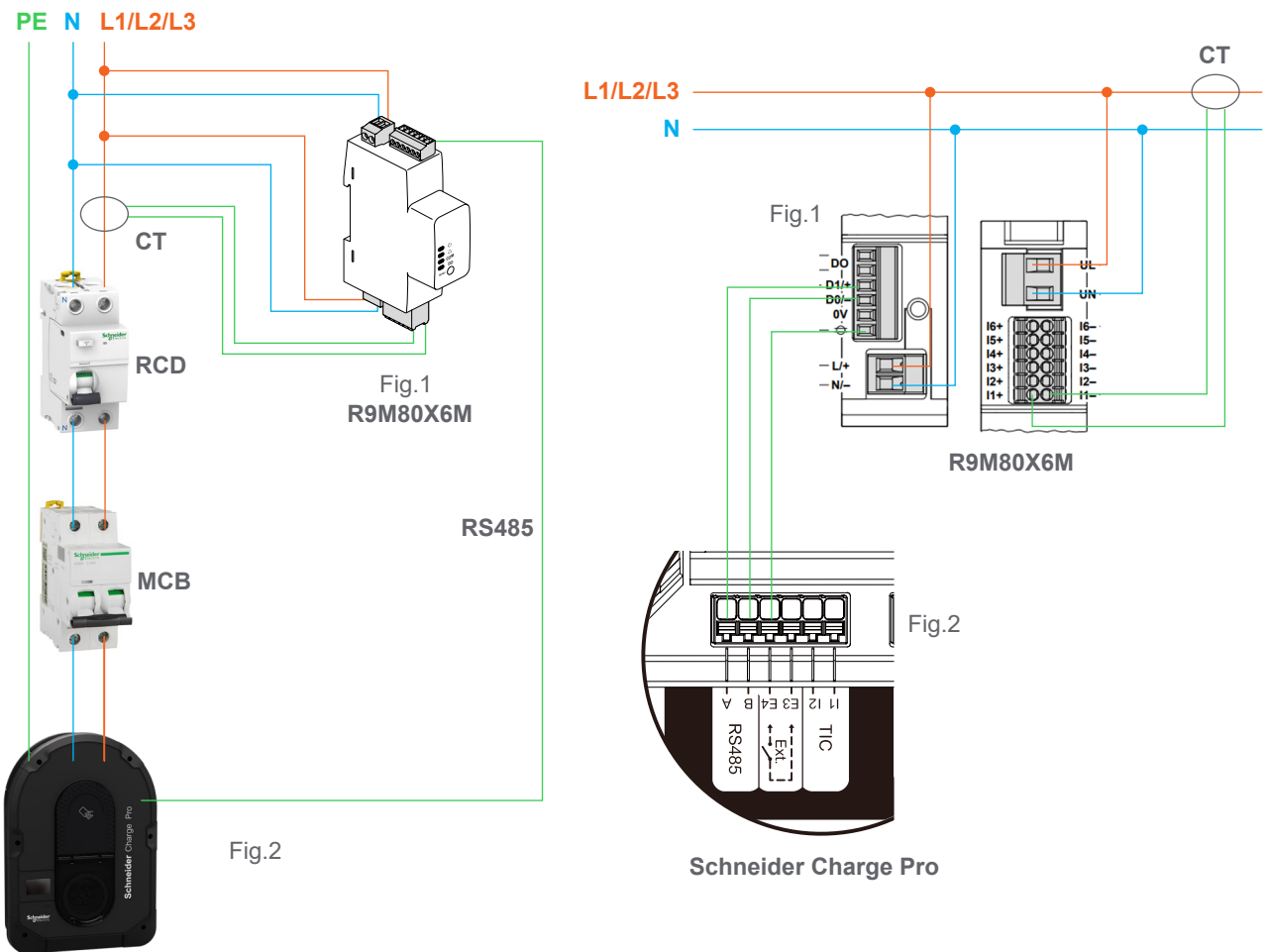

Schneider Charge Pro

# Wiring Diagram of R9MUX6M

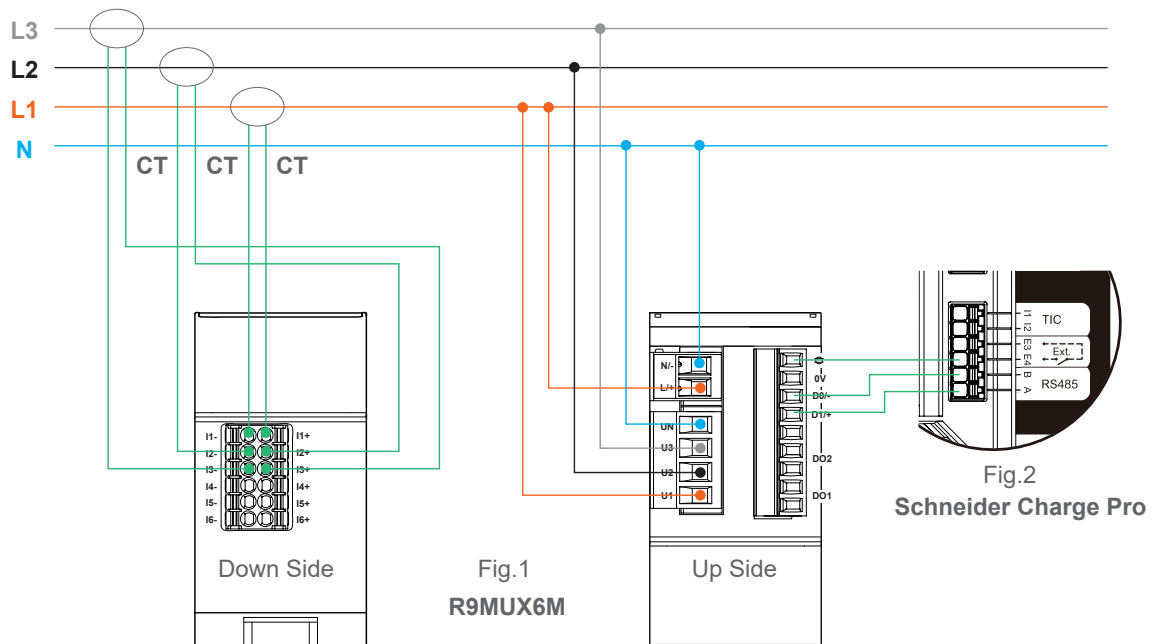
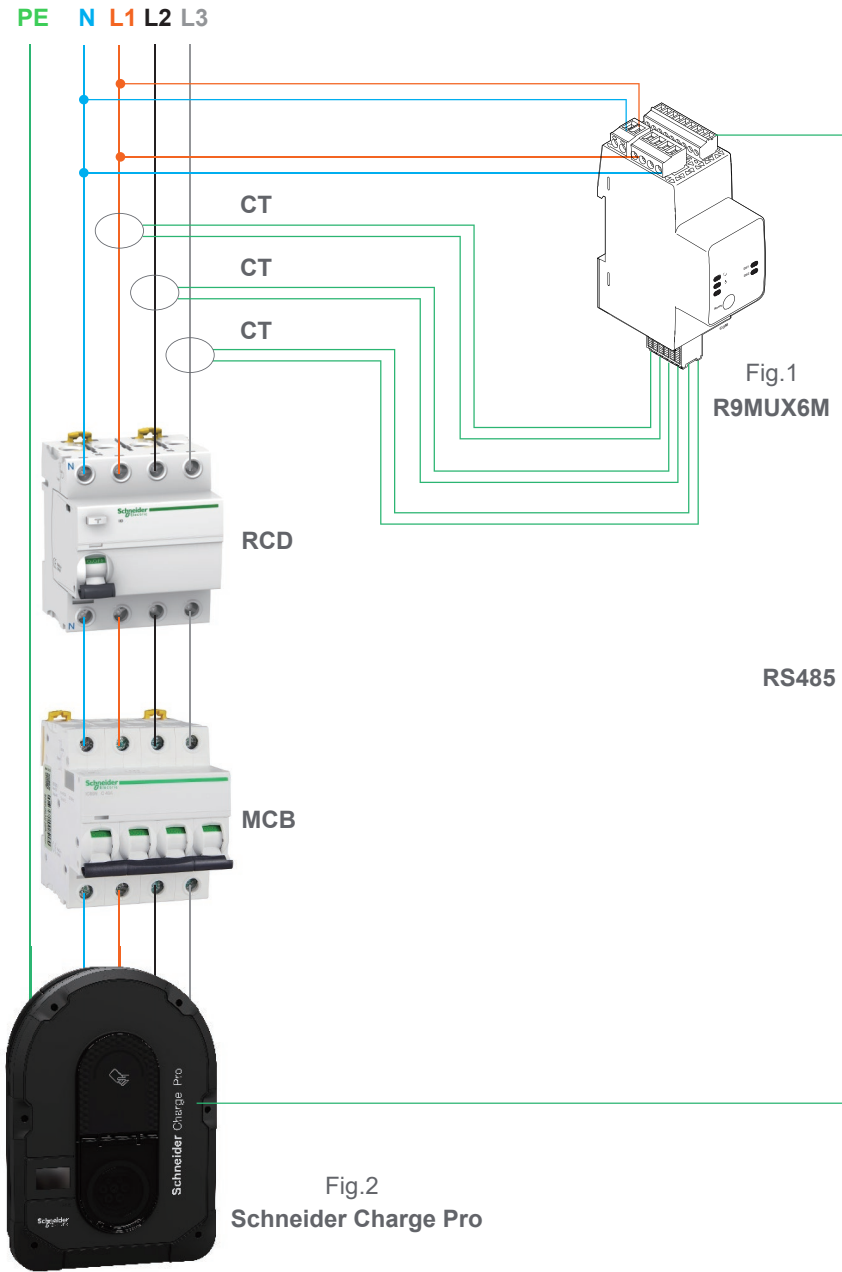

**NOTE:**

- When installing the CT on the cable, pay attention to the correct direction of the phase in relation to the source. Wrong direction generates negative outputs (negative energy).
- While using more than one cable with 1 CT, pay attention to the same direction.

**R9MCT80**

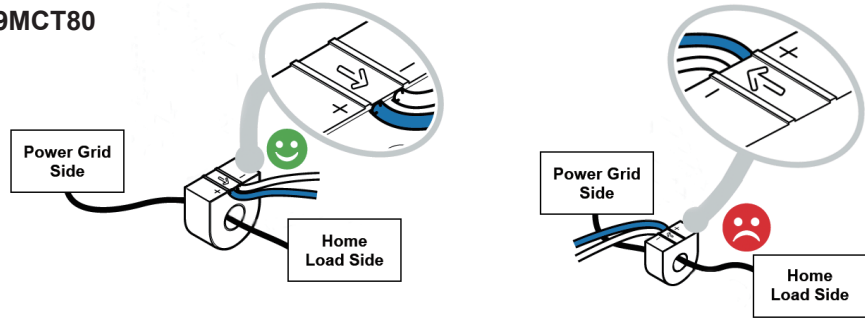

**R9MCT160, R9MCT250**

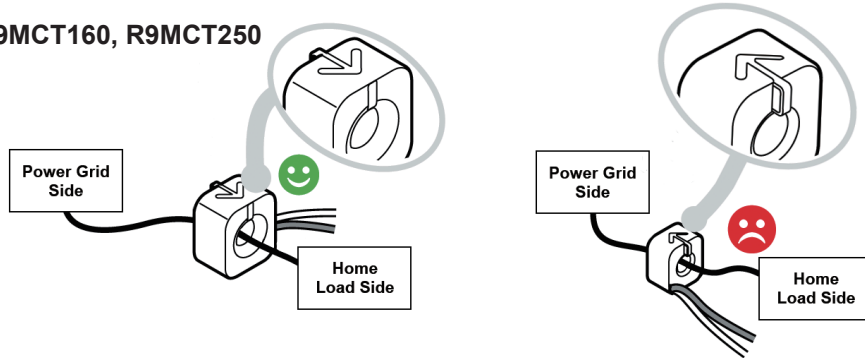

**RS485 Port Setup**

The Energy sensor is factory-configured with default serial communication settings:

- Protocol = Modbus RTU
- Address = 1
- Baud rate = 19,200
- Data bit = E81 (Even checksum, 8 data bits, 1 stop bit)

**Modbus Table**

The Energy sensor provides highly accurate measurement data or calculated average value of a second time for the true RMS (root mean square) value for below listed items:

- Voltage (single phase)
- Current per circuit
- Active Power (W) per circuit
- Power factor per circuit
- Frequency

For PowerTag Energy Resi9 + Charge load management feature, we only used Voltage (single phase), Current per circuit and Active Power (W) per circuit register to implement the feature. The Modbus table as below.

<b>Current</b>						
Current L1	Y	3000	A	2	FLOAT32	R
Current L2	Y	3002	A	2	FLOAT32	R
Current L3	Y	3004	A	2	FLOAT32	R
Current L4	Y	3006	A	2	FLOAT32	R
Current L5	Y	3008	A	2	FLOAT32	R
Current L6	Y	3010	A	2	FLOAT32	R
<b>Voltage</b>						
Voltage	Y	3020	V	2	FLOAT32	R
<b>Power</b>						
Active Power L1	Y	3054	kw	2	FLOAT32	R
Active Power L2	Y	3056	kw	2	FLOAT32	R
Active Power L3	Y	3058	kw	2	FLOAT32	R
Active Power L4	Y	3060	kw	2	FLOAT32	R
Active Power L5	Y	3062	kw	2	FLOAT32	R
Active Power L6	Y	3064	kw	2	FLOAT32	R

The corresponding RS485 port setting registers can be found in the Modbus register table, which can be downloaded from the web page: [www.se.com](http://www.se.com).

For more information of PowerTag Energy Resi9, please scan QR code below to get Resi9 Energy Meter Wired – Device user guide for more details in use.



# Connectivity with P1 Smart meter

## Introduction

The function of P1 smart meter + P1MB gateway + Charge Pro is to implement load management. To enable this feature, you need to conduct commissioning through eSetup. Please refer to Schneider Charge Pro Commissioning Guide BRU9949500 for more details.

## P1MB Product Information

P1MB is a device which interfaces to the P1 port of a smart meter and transforms the data and make it available on its Modbus slave interface to be read out via a Modbus RTU.



The P1MB is connected via an RJ12 connection to the P1 port of a smart meter. The device is powered by the +5V of the P1 port of the connected smart meter. If not available, the P1MB can optionally be powered by an external adapter connected to the DC power interface.

The P1MB enables the request line of the P1 port and captures every second the P1 data in its Modbus memory map. The P1MB acts as a Modbus slave and can be read out by a Modbus RTU master connected to the RS485 interface.

In order to charge an electrical vehicle as quickly as possible, a residential charging station needs to know how much power of the total available grid connection is in use by the household appliances and how much is available for charging. Using the P1MB device, the charging station can get this information through a Modbus interface from a smart meter.

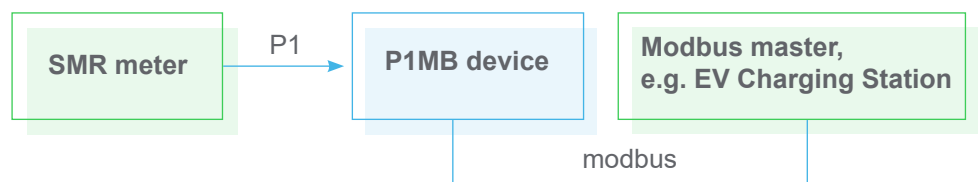

Complete information about the device, including operation, configuration and using the product can ask for:

[support@xemex.eu](mailto:support@xemex.eu)

## Tools Supplied by User

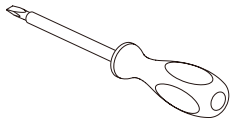

2 mm/0,8 in  
4 mm/1,6 in

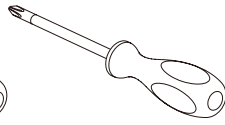

PH2

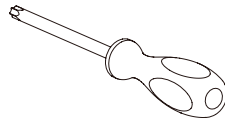

T20 security

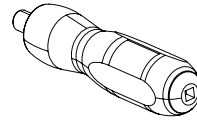

0,5 Nm - 3,5 Nm  
Torque driver

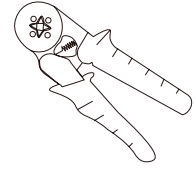

## Wiring Diagram

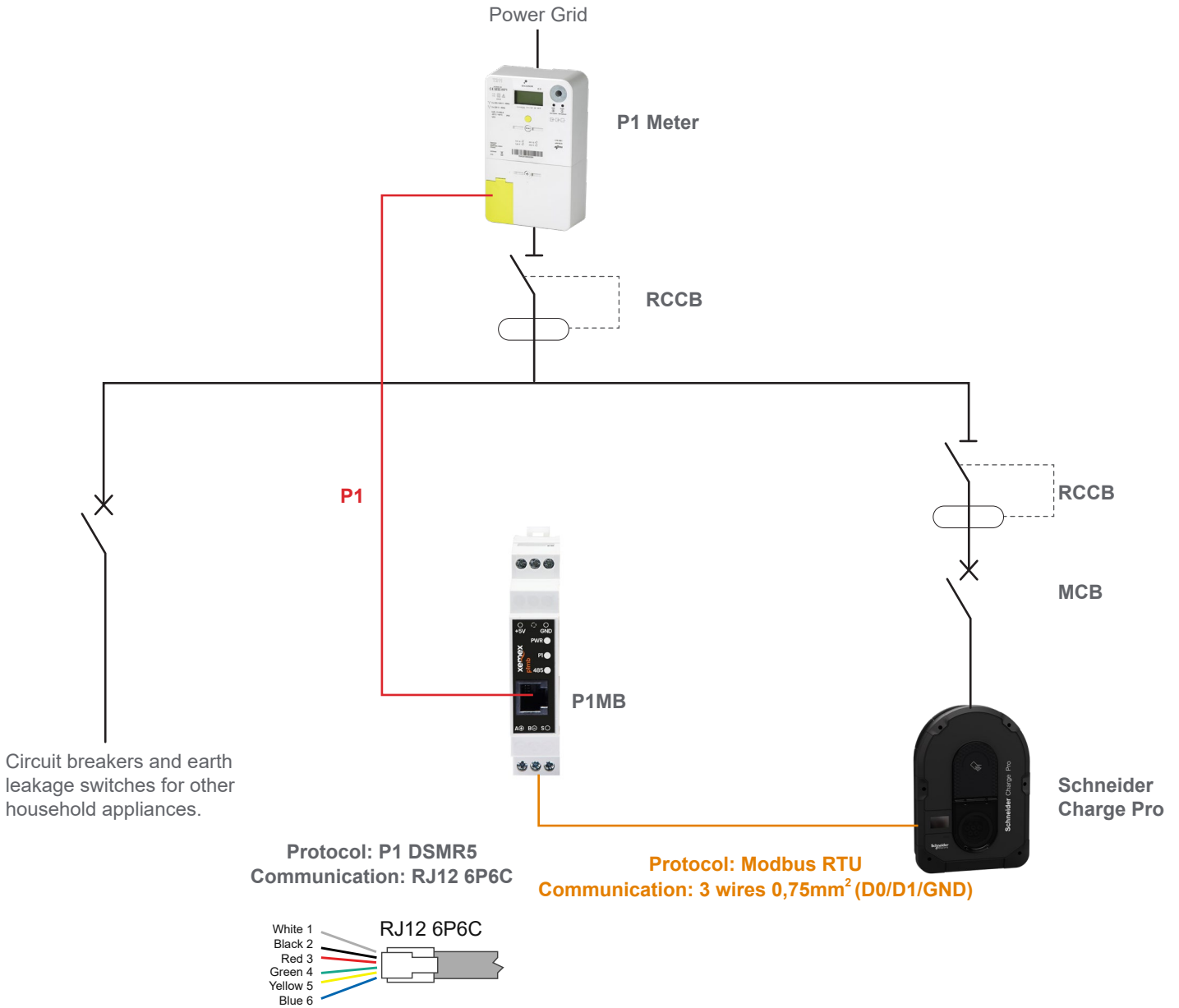

## D1 Power Interface

Connector Screw terminal connector for 0V and +5V DC  
 Voltage range: 5V DC, -10%, +10%  
 Max current consumption: 50 mA  
 Max cable length: 3 meters  
 Cable location: indoor + outdoor  
 Reverse polarity protection: yes

## P1 Interface

Protocol P1 protocol conform DSMR5

Max cable length: 3 meters

Cable location: indoor

Connector RJ12 – 6 pins

Pin definition:

Pin #	Signal name	Description	Remark
1	+5V	+5V power supply	Power <b>input</b> for P1MB device
2	Data Request	Data Request	<b>Output</b> for P1MB device
3	Data GND	Data ground	
4	n.c.	Not connected	
5	Data	Data line	<b>Input</b> . Current source PU.
6	Power GND	Power ground	

## RS485 Port Setup

Connector Screw terminal connector for A, B and Shield

Bus termination 120 Ohm, switchable on/off

Protocol Modbus RTU over RS485

Max cable length: 100 meters

Cable location: indoor + outdoor

The P1MB is factory-configured with default serial communication settings:

- Protocol = Modbus RTU
- Address = 16
- Baud rate = 9600
- Data bit = 8E1 (Even checksum, 8 data bits, 1 stop bit)

## Modbus Table

For P1 Smart meter + P1MB + Charge load management feature, we only used Voltage per phase, Current per circuit and Active Power (W) per circuit register to implement the feature. The Modbus table as below,

761	2	Instantaneous voltage L1 -V alue	1-0:32.7.0	UINT32
763	2	Instantaneous voltage L2 - Value	1-0:52.7.0	UINT32
765	2	Instantaneous voltage L3 - Value	1-0:72.7.0	UINT32
767	1	Instantaneous current L1 - Value	1-0:31.7.0	UINT16
769	1	Instantaneous current L2 - Value	1-0:51.7.0	UINT16
771	1	Instantaneous current L3 - Value	1-0:71.7.0	UINT16
773	2	Instantaneous active power (+P) L1 - Value	1-0:21.7.0	UINT32
775	2	Instantaneous active power (+P) L2 - Value	1-0:41.7.0	UINT32
777	2	Instantaneous active power (+P) L3 - Value	1-0:61.7.0	UINT32
779	2	Instantaneous active power (-P) L1 - Value	1-0:22.7.0	UINT32
781	2	Instantaneous active power (-P) L2 - Value	1-0:42.7.0	UINT32
783	2	Instantaneous active power (-P) L3 - Value	1-0:62.7.0	UINT32

Schneider Electric  
35 rue Joseph Monier  
92500 Rueil Malmaison  
France

+ 33 (0) 1 41 29 70 00

[www.se.com](http://www.se.com)

As standards, specifications, and design change from time to time,  
please ask for confirmation of the information given in this publication.

© 2025 Schneider Electric. All rights reserved.

NAT3046700-02