

Altivar 71

User's manual

Retain for future use

Modbus/Uni-Telway card
Modbus protocol

VW3 A3 303

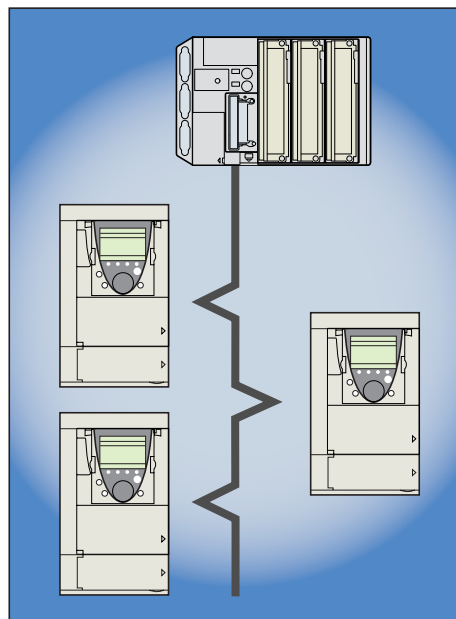

Contents

1. Before you begin	3
2. Documentation structure	4
3. Introduction	5
3. 1. Presentation	5
3. 2. Notation	5
4. Hardware setup	6
4. 1. Receipt	6
4. 2. Hardware description	6
4. 3. Installing the card in the drive	6
4. 4. Switch coding	7
5. Connecting to the bus	9
5. 1. Wiring recommendations	9
5. 2. Modbus RS485 standard	9
5. 3. Connection via RJ45 wiring system	10
5. 4. Connection via junction boxes	12
6. Configuration	14
6. 1. Communication parameters	14
6. 2. Control - Command	15
6. 3. Communication scanner	18
6. 4. Communication faults	19
6. 5. Monitored parameters	20
7. Diagnostics	21
7. 1. Checking the address	21
7. 2. LEDs	21
7. 3. Control - Command	22
7. 4. Communication scanner	23
7. 5. Communication fault	24
7. 6. Card fault	24
8. Modbus protocol	25
8. 1. Principle	25
8. 2. Modes	26
8. 3. Modbus functions available	27
8. 4. Read Holding/Input Registers (3/4)	27
8. 5. Write Single Register (6)	28
8. 6. Diagnostics (8)	29
8. 7. Get Comm Event Counter (11 = 16#0B)	30
8. 8. Write Multiple Registers (16 = 16#10)	30
8. 9. Read/Write Multiple Registers (23 = 16#17)	31
8. 10. Read Device Identification (43 = 16#2B)	32
8. 11. Communication scanner	34
8. 12. Exception responses	37
8. 13. Read non-existent or protected parameters	38
9. Appendix	39
9. 1. RS485 standard	39
9. 2. Modbus 2-wire standard schematic	40
9. 3. Modbus 4-wire standard schematic	41
9. 4. Uni-Telway schematic	42
9. 5. 2-wire Jbus schematic	43
9. 6. Creating a Modbus bus using non-standard equipment	44
9. 7. RS485 schematic for the card	46
9. 8. Card connector pinout	46

While every precaution has been taken in the preparation of this document, Schneider Electric SA assumes no liability for any omissions or errors it may contain, nor for any damages resulting from the application or use of the information herein.

The products and options described in this document may be changed or modified at any time, either from a technical point of view or in the way they are operated. Their description can in no way be considered contractual.

1. Before you begin

Read and understand these instructions before performing any procedure with this drive.

DANGER

HAZARDOUS VOLTAGE

- Read and understand the Installation Manual before installing or operating the Altivar 71 drive. Installation, adjustment, repair, and maintenance must be performed by qualified personnel.
- The user is responsible for compliance with all international and national electrical standards in force concerning protective grounding of all equipment.
- Many parts of this variable speed drive, including the printed circuit boards, operate at the line voltage. **DO NOT TOUCH.** Use only electrically insulated tools.
- **DO NOT** touch unshielded components or terminal strip screw connections with voltage present.
- **DO NOT** short across terminals PA/+ and PC/- or across the DC bus capacitors.
- Install and close all covers before applying power or starting and stopping the drive.
- Before servicing the variable speed drive
 - Disconnect all power.
 - Place a "DO NOT TURN ON" label on the variable speed drive disconnect.
 - Lock the disconnect in the open position.
- Disconnect all power including external control power that may be present before servicing the drive. **WAIT 15 MINUTES** to allow the DC bus capacitors to discharge. Then follow the DC bus voltage measurement procedure given in the installation manual to verify that the DC voltage is less than 45 VDC. The drive LEDs are not accurate indicators of the absence of DC bus voltage.

Electric shock will result in death or serious injury.

CAUTION

EQUIPMENT DAMAGE

Do not operate or install any drive that appears damaged.
Failure to follow these instructions can result in equipment damage.

2. Documentation structure

The following Altivar 71 technical documents are available on the Telemecanique website (www.telemecanique.com) as well as on the CD-ROM supplied with the drive.

■ Installation Manual

This manual describes:

- How to assemble the drive
- How to connect the drive

■ Programming Manual

This manual describes:

- The functions
- The parameters
- How to use the drive display terminal (integrated display terminal and graphic display terminal)

■ Communication Parameters Manual

This manual describes:

- The drive parameters with specific information (addresses, formats, etc.) for use via a bus or communication network
- The operating modes specific to communication (state chart)
- The interaction between communication and local control

■ Modbus, CANopen, Ethernet, Profibus, INTERBUS, Uni-Telway, DeviceNet, Modbus Plus and FIPIO manuals

These manuals describe:

- Connection to the bus or network
- Configuration of the communication-specific parameters via the integrated display terminal or the graphic display terminal
- Diagnostics
- Software setup
- The communication services specific to the protocol

■ Altivar 58/58F Migration Manual

This manual describes the differences between the Altivar 71 and the Altivar 58/58F.

It explains how to replace an Altivar 58 or 58F, including how to replace drives communicating on a bus or network.

3. Introduction

3. 1. Presentation

The communication card (catalog number **VW3 A8 303**) is used to connect an Altivar 71 drive to a Uni-Telway or Modbus bus.

This manual only describes how to use the Modbus protocol. For Uni-Telway, please refer to the Uni-Telway protocol manual.

The data exchanges permit access to all Altivar 71 functions:

- Configuration
- Adjustment
- Control and command
- Monitoring
- Diagnostics

The card has a female 9-way SUB-D connector for connection to the Modbus bus.
The connection cables and accessories should be ordered separately.

The drive address should be configured using the switches on the card.

The graphic display terminal or the integrated display terminal offer numerous functions for communication diagnostics.

Note: The Modbus card supports the following services in addition to those provided by the drive's integrated ports:

- 2-wire and 4-wire RS485
- Choice of line polarization
- RTU and ASCII modes
- More diagnostic subcodes
- More Modbus functions (04: Read Input Registers and 11: Get Comm Event Counter)

3. 2. Notation

Drive terminal displays

The graphic display terminal menus are shown in square brackets.

Example: [1.9 COMMUNICATION]

The integrated 7-segment display terminal menus are shown in round brackets.

Example: (C D P -)

Parameter names displayed on the graphic display terminal are shown in square brackets.

Example: [Fallback speed]

Parameter codes displayed on the integrated 7-segment display terminal are shown in round brackets.

Example: (L F F)

Formats

Hexadecimal values are written as follows: 16#

Binary values are written as follows: 2#

Abbreviations

Hi: High order

Lo: Low order

4. Hardware setup

4. 1. Receipt

Check that the card catalog number marked on the label is the same as that on the delivery note corresponding to the purchase order. Remove the option card from its packaging and check that it has not been damaged in transit.

4. 2. Hardware description

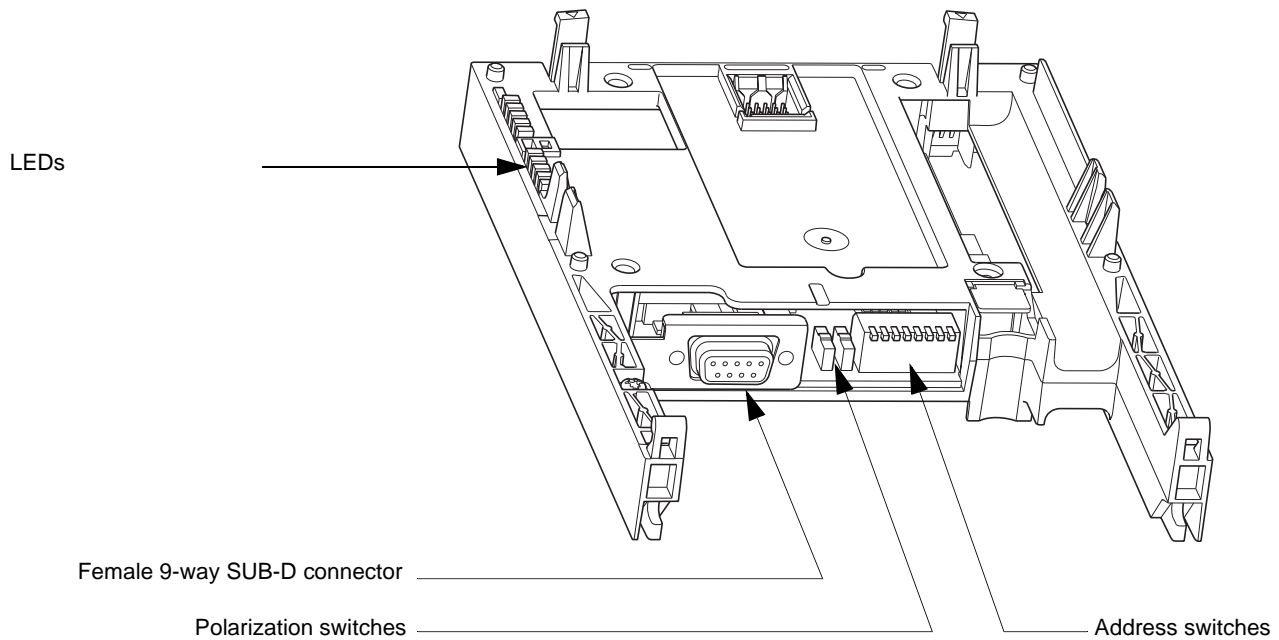

4. 3. Installing the card in the drive

See the Installation Manual.

4. Hardware setup

4. 4. Switch coding

■ Choosing polarization

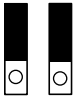

Normal setting for a Modbus bus:
• No polarization at drive level

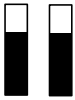

Special setting (see "Creating a Modbus bus using non-standard equipment" on page [44](#)):
• 4.7 kΩ RS485 line polarization at drive level

■ Coding the address

The address switches are used to encode the address (1 to 247) of the drive on the bus.

The switch settings can only be changed when the drive is turned off.

The correspondence between the value and the position of the switch is as follows:

- 0 = OFF = Switch in upper position
- 1 = ON = Switch in lower position

The address is binary-coded.

Examples:



Address 11 = 2#0000 1011



Address 34 = 2#0010 0010

4. Hardware setup

The table below indicates the positions of the 8 switches for all configurable addresses:

Address	Switches 1234 5678	Address	Switches 1234 5678	Address	Switches 1234 5678	Address	Switches 1234 5678	Address	Switches 1234 5678
0	0000 0000	52	0011 0100	104	0110 1000	156	1001 1100	208	1101 0000
1	0000 0001	53	0011 0101	105	0110 1001	157	1001 1101	209	1101 0001
2	0000 0010	54	0011 0110	106	0110 1010	158	1001 1110	210	1101 0010
3	0000 0011	55	0011 0111	107	0110 1011	159	1001 1111	211	1101 0011
4	0000 0100	56	0011 1000	108	0110 1100	160	1010 0000	212	1101 0100
5	0000 0101	57	0011 1001	109	0110 1101	161	1010 0001	213	1101 0101
6	0000 0110	58	0011 1010	110	0110 1110	162	1010 0010	214	1101 0110
7	0000 0111	59	0011 1011	111	0110 1111	163	1010 0011	215	1101 0111
8	0000 1000	60	0011 1100	112	0111 0000	164	1010 0100	216	1101 1000
9	0000 1001	61	0011 1101	113	0111 0001	165	1010 0101	217	1101 1001
10	0000 1010	62	0011 1110	114	0111 0010	166	1010 0110	218	1101 1010
11	0000 1011	63	0011 1111	115	0111 0011	167	1010 0111	219	1101 1011
12	0000 1100	64	0100 0000	116	0111 0100	168	1010 1000	220	1101 1100
13	0000 1101	65	0100 0001	117	0111 0101	169	1010 1001	221	1101 1101
14	0000 1110	66	0100 0010	118	0111 0110	170	1010 1010	222	1101 1110
15	0000 1111	67	0100 0011	119	0111 0111	171	1010 1011	223	1101 1111
16	0001 0000	68	0100 0100	120	0111 1000	172	1010 1100	224	1110 0000
17	0001 0001	69	0100 0101	121	0111 1001	173	1010 1101	225	1110 0001
18	0001 0010	70	0100 0110	122	0111 1010	174	1010 1110	226	1110 0010
19	0001 0011	71	0100 0111	123	0111 1011	175	1010 1111	227	1110 0011
20	0001 0100	72	0100 1000	124	0111 1100	176	1011 0000	228	1110 0100
21	0001 0101	73	0100 1001	125	0111 1101	177	1011 0001	229	1110 0101
22	0001 0110	74	0100 1010	126	0111 1110	178	1011 0010	230	1110 0110
23	0001 0111	75	0100 1011	127	0111 1111	179	1011 0011	231	1110 0111
24	0001 1000	76	0100 1100	128	1000 0000	180	1011 0100	232	1110 1000
25	0001 1001	77	0100 1101	129	1000 0001	181	1011 0101	233	1110 1001
26	0001 1010	78	0100 1110	130	1000 0010	182	1011 0110	234	1110 1010
27	0001 1011	79	0100 1111	131	1000 0011	183	1011 0111	235	1110 1011
28	0001 1100	80	0101 0000	132	1000 0100	184	1011 1000	236	1110 1100
29	0001 1101	81	0101 0001	133	1000 0101	185	1011 1001	237	1110 1101
30	0001 1110	82	0101 0010	134	1000 0110	186	1011 1010	238	1110 1110
31	0001 1111	83	0101 0011	135	1000 0111	187	1011 1011	239	1110 1111
32	0010 0000	84	0101 0100	136	1000 1000	188	1011 1100	240	1111 0000
33	0010 0001	85	0101 0101	137	1000 1001	189	1011 1101	241	1111 0001
34	0010 0010	86	0101 0110	138	1000 1010	190	1011 1110	242	1111 0010
35	0010 0011	87	0101 0111	139	1000 1011	191	1011 1111	243	1111 0011
36	0010 0100	88	0101 1000	140	1000 1100	192	1100 0000	244	1111 0100
37	0010 0101	89	0101 1001	141	1000 1101	193	1100 0001	245	1111 0101
38	0010 0110	90	0101 1010	142	1000 1110	194	1100 0010	246	1111 0110
39	0010 0111	91	0101 1011	143	1000 1111	195	1100 0011		1111 0111
40	0010 1000	92	0101 1100	144	1001 0000	196	1100 0100		1111 1000
41	0010 1001	93	0101 1101	145	1001 0001	197	1100 0101		1111 1001
42	0010 1010	94	0101 1110	146	1001 0010	198	1100 0110		1111 1010
43	0010 1011	95	0101 1111	147	1001 0011	199	1100 0111	247	1111 1011
44	0010 1100	96	0110 0000	148	1001 0100	200	1100 1000		1111 1100
45	0010 1101	97	0110 0001	149	1001 0101	201	1100 1001		1111 1101
46	0010 1110	98	0110 0010	150	1001 0110	202	1100 1010		1111 1110
47	0010 1111	99	0110 0011	151	1001 0111	203	1100 1011		1111 1111
48	0011 0000	100	0110 0100	152	1001 1000	204	1100 1100		
49	0011 0001	101	0110 0101	153	1001 1001	205	1100 1101		
50	0011 0010	102	0110 0110	154	1001 1010	206	1100 1110		
51	0011 0011	103	0110 0111	155	1001 1011	207	1100 1111		

Note: Address 0 is not valid.

5. Connecting to the bus

5. 1. Wiring recommendations

- Use Telemecanique-approved cables and wiring accessories to ensure good transmission quality (matched impedance, immunity, shielding connection, etc.).
- Keep the Modbus cable away from the power cables (30 cm minimum).
- Be sure to cross the Modbus cable and the power cables at right angles.
- Whenever possible, connect the bus cable shielding to the protective ground, e.g., to the ground of each device if this ground is connected to the protective ground.
- Install a line terminator at both ends of the line.
- Ensure the correct line polarization.
- Connect the common polarity ("Common" signal) to the protective ground at one or more points on the bus.

For more information, please refer to the TSX DG KBL E guide: "Electromagnetic compatibility of industrial networks and fieldbuses".

5. 2. Modbus RS485 standard

The characteristics and accessories mentioned in this section ("5. Connecting to the bus") comply with the Modbus standard. Other non-Modbus-standard RS485 wiring diagrams are possible. Please see the Appendix for further information. The latest generation of Telemecanique equipment conforms to Modbus (2-wire RS485).

Main characteristics:

Maximum length of bus	1000 m at 19,200 bps
Maximum number of stations	32 stations, i.e., 31 slaves (without repeater)

5. Connecting to the bus

5.3. Connection via RJ45 wiring system

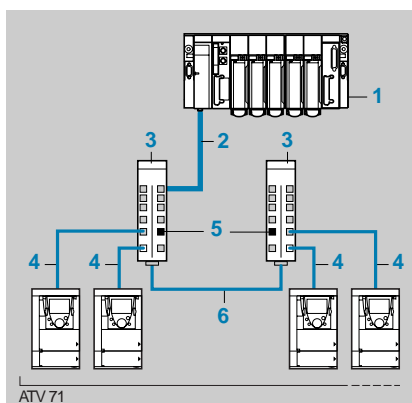

1. Master (PLC, PC or communication module)
2. Cable depending on the type of master (see table)
3. Splitter block **LU9 GC3**
4. Drop cable **VW3 A58 306 R●●**
5. Line terminators **VW3 A8 306 RC**
6. Modbus cable **TSX CSA ●00**

■ Connection accessories

Description		Ref.	Catalog number
Modbus splitter block	10 RJ45 connectors and 1 screw terminal block	3	LU9 GC3
Modbus T-junction boxes	With integrated cable (0.3 m)		VW3 A8 306 TF03
	With integrated cable (1 m)		VW3 A8 306 TF10
Line terminators For RJ45 connector	R = 120 Ω, C = 1 nF	5	VW3 A8 306 RC
	R = 150 Ω (specific to "Jbus schematic" page 43)	5	VW3 A8 306 R

■ Connection cables

Description	Length (m)	Connectors	Ref.	Catalog number
Cables for Modbus bus	1	1 RJ45 connector and 1 male 9-way SUB-D connector	4	VW3 A58 306 R10
	3	1 RJ45 connector and 1 male 9-way SUB-D connector	4	VW3 A58 306 R30
	3	1 RJ45 connector and 1 stripped end		VW3 A8 306 D30
	0.3	2 RJ45 connectors		VW3 A8 306 R03
	1	2 RJ45 connectors		VW3 A8 306 R10
	3	2 RJ45 connectors		VW3 A8 306 R30
RS485 double shielded twisted pair cables	100	Supplied without connector	6	TSX CSA 100
	200	Supplied without connector	6	TSX CSA 200
	500	Supplied without connector	6	TSX CSA 500

5. Connecting to the bus

■ Connection cables for the master

Type of master	Master interface	Description	Catalog number
Twido PLC	Adaptor or mini-DIN RS485 interface module	3 m cable equipped with a mini-DIN connector and an RJ45 connector	TWD XCA RJ030
	Adaptor or screw terminal RS485 interface module	3 m cable equipped with an RJ45 connector and stripped at the other end	VW3 A8 306 D30
TSX Micro PLC	Mini-DIN RS485 connector port	3 m cable equipped with a mini-DIN connector and an RJ45 connector	TWD XCA RJ030
	PCMCIA card (TSX SCP114)	Stripped cable	TSX SCP CM 4030
TSX Premium PLC	TSX SCY 11601 or TSX SCY 21601 module (25-way SUB-D socket)	Cable equipped with a 25-way SUB-D connector and stripped at the other end (for connection to the screw terminals of the LU9GC3 splitter block)	TSX SCY CM 6030
	PCMCIA card (TSX SCP114)	Stripped cable	TSX SCP CM 4030
Ethernet bridge (174 CEV 300 20)	Screw terminal RS485	3 m cable equipped with an RJ45 connector and stripped at the other end	VW3 A8 306 D30
Profibus DP gateway (LA9P307)	RJ45 RS485	1 m cable equipped with 2 RJ45 connectors	VW3 P07 306 R10
Fipio (LUFP1) or Profibus DP (LUFP7) or DeviceNet (LUFP9) gateway	RJ45 RS485	0.3 m cable equipped with 2 RJ45 connectors or 1 m cable equipped with 2 RJ45 connectors or 3 m cable equipped with 2 RJ45 connectors	VW3 A8 306 R03 or VW3 A8 306 R10 or VW3 A8 306 R30
Serial port PC	Male 9-way SUB-D RS232 serial port PC	RS232/RS485 converter and 3 m cable equipped with an RJ45 connector and stripped at the other end (for connection to the screw terminals of the LU9GC3 splitter block)	TSX SCA 72 and VW3 A8 306 D30

5. Connecting to the bus

5. 4. Connection via junction boxes

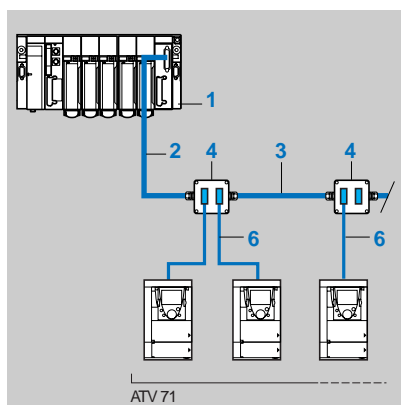

1. Master (PLC, PC or communication module)
2. Modbus cable depending on the type of master (see table)
3. Modbus cable **TSX CSA●00**
4. Subscriber sockets **TSX SCA 62**
5. Modbus drop cable **VW3 A8 306 2**

■ Connection accessories

Description	Ref.	Catalog number
Subscriber socket 2 female 15-way SUB-D connectors, 2 screw terminals, and an RC line terminator, to be connected using cable VW3 A8 306 or VW3 A8 306 D30	4	TSX SCA 62

■ Connection cables

Description	Length (m)	Connectors	Ref.	Catalog number
Cables for Modbus bus	3	1 9-way SUB-D connector and 1 male 15-way SUB-D connector for TSX SCA 62	6	VW3 A8 306 2
RS485 double shielded twisted pair cables	100	Supplied without connector	3	TSX CSA 100
	200	Supplied without connector	3	TSX CSA 200
	500	Supplied without connector	3	TSX CSA 500

5. Connecting to the bus

■ Connection cables for the master

Type of master	Master interface	Description	Catalog number
Twido PLC	Adaptor or screw terminal RS485 interface module	Modbus cable	TSX CSA100 or TSX CSA200 or TSX CSA500
TSX Micro PLC	Mini-DIN RS485 connector port	Tap junction	TSX P ACC 01
	PCMCIA card (TSX SCP114)	Cable equipped with a special connector and stripped at the other end	TSX SCP CM 4030
TSX Premium PLC	TSX SCY 11601 or TSX SCY 21601 module (25-way SUB-D socket)	Cable equipped with a 25-way SUB-D connector and stripped at the other end	TSX SCY CM 6030
	PCMCIA card (TSX SCP114)	Cable equipped with a special connector and stripped at the other end	TSX SCP CM 4030
Ethernet bridge (174 CEV 300 10)	Screw terminal RS485	Modbus cable	TSX CSA100 or TSX CSA200 or TSX CSA500
Profibus DP gateway (LA9P307)	RJ45 RS485	3 m cable equipped with an RJ45 connector and stripped at the other end	VW3 A8 306 D30
Fipio (LUFP1) or Profibus DP (LUFP7) or DeviceNet (LUFP9) gateway	RJ45 RS485	3 m cable equipped with an RJ45 connector and stripped at the other end	VW3 A8 306 D30
Serial port PC	Male 9-way SUB-D RS232 serial port PC	RS232/RS485 converter and Modbus cable	TSX SCA 72 and TSX CSA100 or TSX CSA200 or TSX CSA500

6. Configuration

6. 1. Communication parameters

Configure the following parameters in the [1.9 - COMMUNICATION] (C D N -) menu, [Uni-Telway/Modbus] (U E L -) submenu: [Protocol] (P r D), [Bit rate] (b d r) and [Format] (F D r).

These parameters can only be modified when the motor is stopped. Modifications can only be taken into account by the drive following a power break.

Parameter	Possible values	Terminal display	Default value
[Protocol] (P r D)	Uni-Telway Modbus/RTU Modbus/ASCII	[Unitelway] (U E E) [Modbus RTU] (r E U) [Modbus ASCII] (A S C)	[Unitelway] (U E E)
[Address] (A d r C)	0 to 247	[0] (0) to [247] (2 4 7)	Value taken from the address switches
[Bit rate] (B d r)	4800 bps 9600 bps 19,200 bps	[4800 Bd] (4 B) [9600 Bd] (9 6) [19200 Bd] (1 9 2)	[19.2 Kbps] (1 9 2)
[Format] (F D r)	In RTU mode only: 8 data bits, odd parity, 1 stop bit 8 data bits, even parity, 1 stop bit 8 data bits, no parity, 1 stop bit 8 data bits, no parity, 2 stop bits	[8-O-1] (B o 1) [8-E-1] (B E 1) [8-N-1] (B n 1) [8-N-2] (B n 2)	[8-O-1] (B o 1)
	In RTU and ASCII modes: 7 data bits, odd parity, 1 stop bit 7 data bits, even parity, 1 stop bit 7 data bits, odd parity, 2 stop bits 7 data bits, even parity, 2 stop bits	[7-O-1] (7 o 1) [7-E-1] (7 E 1) [7-O-2] (7 o 2) [7-E-2] (7 E 2)	

6. Configuration

6.2. Control - Command

Numerous configurations are possible. For more information, refer to the Programming Manual and the Parameters Manual. The following configurations are just some of the possibilities available.

■ Control via Modbus in I/O profile

The command and reference come from Modbus. The command is in I/O profile.

Configure the following parameters:

Parameter	Value	Comment
Profile	I/O profile	The run command is simply obtained by bit 0 of the control word.
Reference 1 configuration	Network card	The reference comes from Modbus.
Command 1 configuration	Network card	The command comes from Modbus.

Configuration via the graphic display terminal or the integrated display terminal:

Menu	Parameter	Value
[1.6 - COMMAND] (C E L -)	[Profile] (C H C F)	[I/O profile] (I O)
	[Ref.1 channel] (F r 1)	[Com. card] (n E E)
	[Cmd channel 1] (C d 1)	[Com. card] (n E E)

■ Control via Modbus or the terminals in I/O profile

Both the command and reference come from Modbus or the terminals. Input LI5 at the terminals is used to switch between Modbus and the terminals. The command is in I/O profile.

Configure the following parameters:

Parameter	Value	Comment
Profile	I/O profile	The run command is simply obtained by bit 0 of the control word.
Reference 1 configuration	Network card	Reference 1 comes from Modbus.
Reference 1B configuration	Analog input 1 on the terminals	Reference 1B comes from input AI1 on the terminals.
Reference switching	Input LI5	Input LI5 switches the reference (1 ↔ 1B).
Command 1 configuration	Network card	Command 1 comes from Modbus.
Command 2 configuration	Terminals	Command 2 comes from the terminals.
Command switching	Input LI5	Input LI5 switches the command.

Note: Reference 1B is directly connected to the drive reference limit. If switching is performed, the functions that affect the reference (summing, PID, etc) are inhibited.

Configuration via the graphic display terminal or the integrated display terminal:

Menu	Parameter	Value
[1.6 - COMMAND] (C E L -)	[Profile] (C H C F)	[I/O profile] (I O)
	[Ref.1 channel] (F r 1)	[Com. card] (n E E)
	[Cmd channel 1] (C d 1)	[Com. card] (n E E)
	[Cmd channel 2] (C d 2)	[Terminals] (E E r)
	[Cmd switching] (C C S)	[LI5] (L I 5)
[1.7 APPLICATION FUNCT.] (F U n -) [REFERENCE SWITCH.]	[Ref.1B channel] (F r 1b)	[Ref. AI1] (A I 1)
	[Ref 1B switching] (r C b)	[LI5] (L I 5)

6. Configuration

■ Control via Modbus in Drivecom profile

The command and reference come from Modbus.
The command is in Drivecom profile.

Configure the following parameters:

Parameter	Value	Comment
Profile	Drivecom profile not separate	The run commands are in Drivecom profile, the command and the reference come from the same channel.
Reference 1 configuration	Network card	The command comes from Modbus.

Configuration via the graphic display terminal or the integrated display terminal:

Menu	Parameter	Value
[1.6 - COMMAND] (C E L -)	[Profile] (C H C F)	[Not separ.] (S I N) (factory setting)
	[Ref. 1] (F r 1)	[Com. card] (n E E)

■ Control via Modbus or the terminals in Drivecom profile

Both the command and reference come from Modbus or the terminals. Input LI5 at the terminals is used to switch between Modbus and the terminals.
The command is in Drivecom profile.

Configure the following parameters:

Parameter	Value	Comment
Profile	Drivecom profile not separate	The run commands follow the Drivecom profile, and the command and reference come from the same channel.
Reference 1 configuration	Network card	Reference 1 comes from Modbus.
Reference 2 configuration	Analog input 1 on the terminals	Reference 2 comes from input AI1 on the terminals.
Reference switching	Input LI5	Input LI5 switches the reference (1 ↔ 2) and the command.

Caution: Reference 2 is directly connected to the drive reference limit. If switching is performed, the functions that affect the reference (summing, PID, etc) are inhibited.

Configuration via the graphic display terminal or the integrated display terminal:

Menu	Parameter	Value
[1.6 - COMMAND] (C E L -)	[Profile] (C H C F)	[Not separ.] (S I N)
	[Ref.1 channel] (F r 1)	[Com. card] (n E E)
	[Ref.2 channel] (F r 2)	[Ref. AI1] (A I I)
	[Ref. 2 switching] (r F C)	[LI5] (L I 5)

6. Configuration

■ Control in Drivecom profile via Modbus and reference switching at the terminals

The command comes from Modbus.

The command comes either from Modbus or from the terminals. Input LI5 at the terminals is used to switch the reference between Modbus and the terminals.

The command is in Drivecom profile.

Configure the following parameters:

Parameter	Value	Comment
Profile	Separate Drivecom profile	The run commands follow the Drivecom profile, and the command and reference can come from different channels.
Reference 1 configuration	Network card	Reference 1 comes from Modbus.
Reference 1B configuration	Analog input 1 on the terminals	Reference 1B comes from input AI1 on the terminals.
Reference switching	Input LI5	Input LI5 switches the reference (1 ↔ 1B).
Command 1 configuration	Network card	Command 1 comes from Modbus.
Command switching	Channel 1	Channel 1 is the command channel.

Note: Reference 1B is directly connected to the drive reference limit. If switching is performed, the functions that affect the reference (summing, PID, etc) are inhibited.

Configuration via the graphic display terminal or the integrated display terminal:

Menu	Parameter	Value
[1.6 - COMMAND] (C L L -)	[Profile] (C H C F)	[Separate] (S E P)
	[Ref.1 channel] (F r 1)	[Com. card] (n E E)
	[Cmd channel 1] (C d 1)	[Com. card] (n E E)
	[Cmd switching] (C C 5)	[ch1 active] (C d 1)
[1.7 APPLICATION FUNCT.] (F U n -) [REFERENCE SWITCH.]	[Ref.1B channel] (F r 1 b)	[Ref. AI1] (A I 1)
	[Ref 1B switching] (r C b)	[LI5] (L I 5)

6. Configuration

6.3. Communication scanner

The communication scanner enables all the application-relevant parameters to be grouped in 2 consecutive word tables so that single read and write operations may be performed. It is even possible to perform a single transaction using the "Read/Write Multiple Registers" (23 = 16#17) function.

The 8 output variables are assigned using the 8 [Scan.Out address] (n C R ●) parameters. They are configured using the graphic display terminal via the [1.9 - COMMUNICATION] (C D P -) menu, [COM. SCANNER OUTPUT] (D C S -) submenu.

The 8 input variables are assigned using the 8 [Scan.IN address] (n P R ●) parameters. They are configured using the graphic display terminal via the [1.9 - COMMUNICATION] (C D P -) menu, [COM. SCANNER INPUT] (I C S -) submenu.

Enter the logic address of the parameter (see the Parameters Manual).

If a [Scan.Out address] (n C R ●) or [Scan.IN address] (n P R ●) parameter equals zero, the corresponding variable is not used by the drive.

These 16 assignment parameters are described in the tables below:

Configuration parameter name	Default assignment of the output variable
[Scan. Out1 address] (n C R 1)	Control word (CMd)
[Scan. Out2 address] (n C R 2)	Speed reference (LFrd)
[Scan. Out3 address] (n C R 3)	Not used
[Scan. Out4 address] (n C R 4)	Not used
[Scan. Out5 address] (n C R 5)	Not used
[Scan. Out6 address] (n C R 6)	Not used
[Scan. Out7 address] (n C R 7)	Not used
[Scan. Out8 address] (n C R 8)	Not used

Configuration parameter name	Default assignment of the input variable
[Scan. IN1 address] (n P R 1)	Status word (EtA)
[Scan. IN2 address] (n P R 2)	Output speed (rFrd)
[Scan. IN3 address] (n P R 3)	Not used
[Scan. IN4 address] (n P R 4)	Not used
[Scan. IN5 address] (n P R 5)	Not used
[Scan. IN6 address] (n P R 6)	Not used
[Scan. IN7 address] (n P R 7)	Not used
[Scan. IN8 address] (n P R 8)	Not used

Example of configuration via the graphic display terminal:

RDY	NET	+0.00Hz	0A
COM. SCANNER INPUT			<input type="checkbox"/>
Scan. IN1 address	:		3201
Scan. IN2 address	:		8604
Scan. IN3 address	:		0
Scan. IN4 address	:		0
Scan. IN5 address	:		0
Code		Quick	<input checked="" type="checkbox"/>
Scan. IN6 address	:		0
Scan. IN7 address	:		0
Scan. IN8 address	:		0

RDY	NET	+0.00Hz	0A
COM. SCANNER OUTPUT			<input type="checkbox"/>
Scan. Out1 address	:		8501
Scan. Out2 address	:		8602
Scan. Out3 address	:		0
Scan. Out4 address	:		0
Scan. Out5 address	:		0
Code		Quick	<input checked="" type="checkbox"/>
Scan. Out6 address	:		0
Scan. Out7 address	:		0
Scan. Out8 address	:		0

Note:

Any modification to parameters [Scan.Out address] (n C R ●) or [Scan.IN address] (n P R ●) must be made with the motor stopped. The master PLC program should be updated to take account of this modification.

6. Configuration

6. 4. Communication faults

A Modbus fault is triggered if the Modbus card does not receive any Modbus requests at its address within a predefined time period (time out). All Modbus request types are taken into account (read, write, etc.). The time out is fixed at 10 s (non-modifiable). The response of the drive in the event of a Modbus communication fault can be configured.

Configuration can be performed using the graphic display terminal or integrated display terminal using the [Network fault mgt] (CLL) parameter in the [1.8 FAULT MANAGEMENT] (FLE-) menu, [COM. FAULT MANAGEMENT] (CLL-) submenu.

RDY	NET	+0.00Hz	0A
COM. FAULT MANAGEMENT			<input type="checkbox"/>
Network fault mgt	:		Freewheel
CANopen fault mgt	:		Freewheel
Modbus fault mgt	:		Freewheel
Code		Quick	<input type="checkbox"/>

The values of the [Network fault mgt] (CLL) parameter, which trigger a [Com. network] (CNF) drive fault, are:

Value	Meaning
[Freewheel] (YES)	Freewheel stop (factory setting)
[Ramp stop] (RNP)	Stop on ramp
[Fast stop] (FSE)	Fast stop
[DC injection] (DCI)	DC injection stop

The values of the [Network fault mgt] (CLL) parameter, which do not trigger a drive fault, are:

Value	Meaning
[Ignore] (ND)	Fault ignored
[Per STT] (SET)	Stop according to configuration of [Type of stop] (SET).
[fallback spd] (LFF)	Switch to fallback speed, maintained as long as the fault is present and the run command is not disabled.
[Spd maint.] (RLS)	The drive maintains the speed at the time the fault occurred, as long as the fault persists and the run command has not been removed.

The fallback speed can be configured via the [Fallback speed] (LFF) parameter in the [1.8 – FAULT MANAGEMENT] (FLE-) menu.

6. Configuration

6. 5. Monitored parameters

It is possible to select up to 4 parameters to display their values in the [1.2 - MONITORING] menu ([COMMUNICATION MAP] submenu) on the graphic display terminal.

The selection is made via the [6 – MONITOR CONFIG.] menu ([6.3 - CONFIG. COMM. MAP] submenu).

Each parameter [Address 1 select] ... [Address 4 select] can be used to choose the logic address of the parameter. Select an address of zero to disable the function.

In the example given here, the monitored words are:

- Parameter 1 = Motor current (LCr): logic address 3204; signed decimal format
- Parameter 2 = Motor torque (Otr): logic address 3205; signed decimal format
- Parameter 3 = Last fault occurred (LFt): logic address 7121; hexadecimal format
- Disabled parameter: address 0; default format: hexadecimal format

RDY	NET	+0.00Hz	0A
6.3 CONFIG. COMM. MAP.			<input type="checkbox"/>
Address 1 select	:		3204
FORMAT 1	:		Signed
Address 2 select	:		3205
FORMAT 2	:		Signed
Address 3 select	:		7121
Code		Quick	<input checked="" type="checkbox"/>
FORMAT 3	:		Hex
Address 4 select	:		0
FORMAT 4	:		Hex

One of the three display formats below can be assigned to each monitored word:

Format	Range	Terminal display
Hexadecimal	0000 ... FFFF	[Hex]
Signed decimal	-32,767 ... 32,767	[Signed]
Unsigned decimal	0 ... 65,535	[Unsigned]

7. Diagnostics

7. 1. Checking the address

On the graphic display terminal or integrated display terminal, check the address that has been coded on the switches using the [\[Address\] \(Adr C\)](#) parameter in the [\[1.9 COMMUNICATION\] \(C D P -\)](#) menu, [\[Uni-Telway / Modbus\] \(U t L -\)](#) submenu. This parameter cannot be modified.

7. 2. LEDs

The Modbus card has 2 LEDs, RUN and ERR, which are visible through the drive cover.

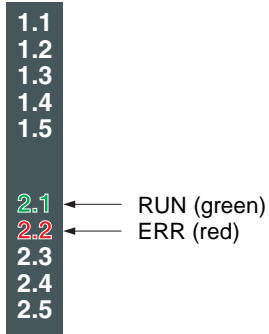

Green RUN LED	Red ERR LED	Meaning	Corrective action
Off	Off	Drive not operating or turned off	Check the power supply.
On	On	Drive starting	
On	Off	Normal operation	
Off	On	Communication fault on the bus	<ul style="list-style-type: none"> • Check the environment (electromagnetic compatibility). • Check the wiring. • Check that the master is communicating within the time out period (= 10 s).
Off	Flashing	Error on character received	<ul style="list-style-type: none"> • Check the environment (electromagnetic compatibility). • Check the communication parameter configuration (protocol, speed, format). • Do not forget that the communication parameter configuration is only taken into account by the drive following a power break. • Check that the slave address is unique.
Flashing	Off	Card fault [internal com. link] (ILF)	<ul style="list-style-type: none"> • Check the environment (electromagnetic compatibility). • Check the card/drive connection. • Check that only one communication card has been installed. • Check that no more than two option cards have been installed. • Replace the communication card. • Inspect or repair the drive.

7. Diagnostics

7.3. Control - Command

On the graphic display terminal only, the [1.2 - MONITORING] menu ([COMMUNICATION MAP] submenu) can be used to display control-signal diagnostic information between the drive and the master:

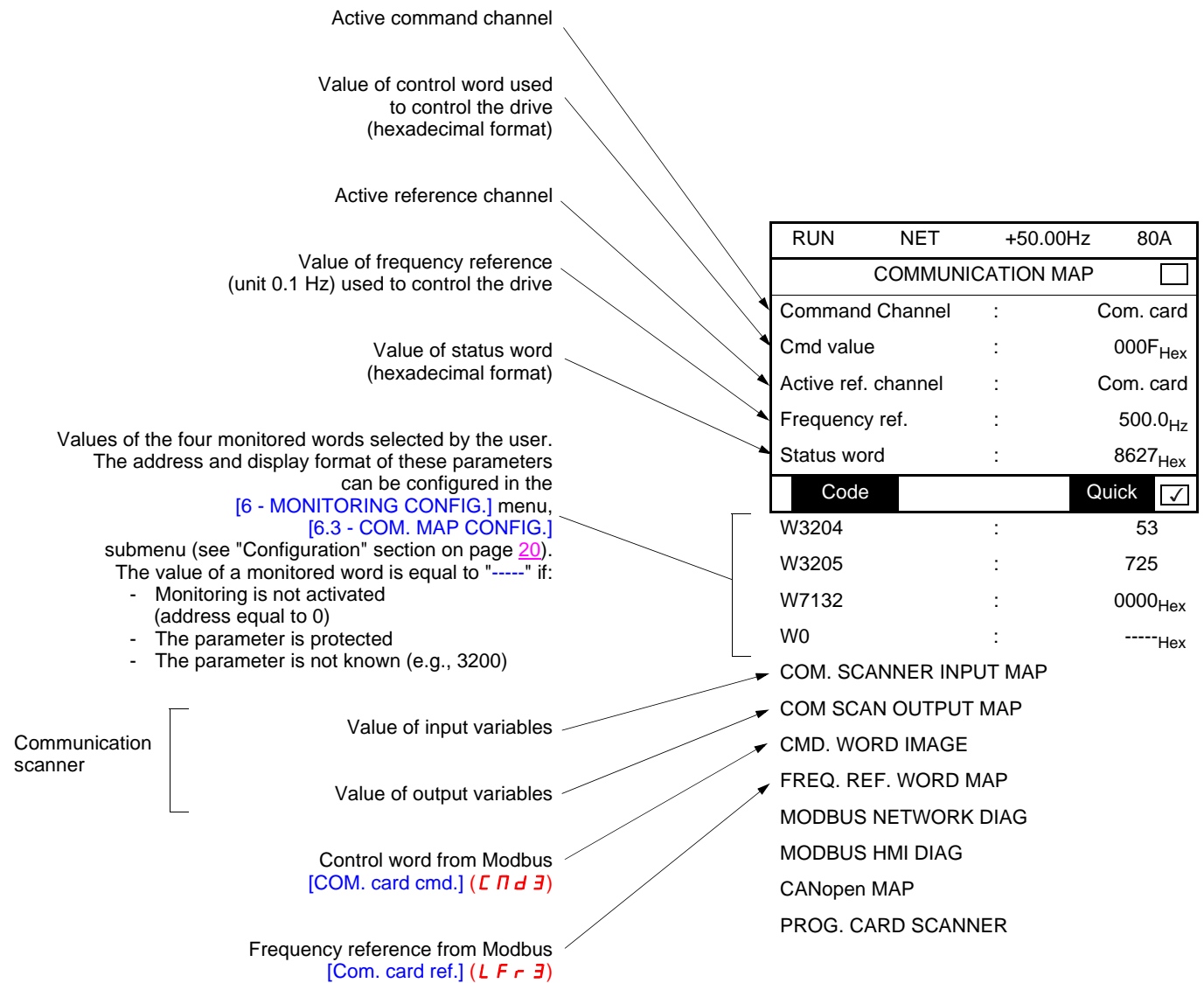

7. Diagnostics

7. 4. Communication scanner

On the graphic display terminal, in the [1.2 - MONITORING] (5 U P -) menu ([COMMUNICATION MAP] (C П П -) submenu):

- The [COM. SCANNER INPUT MAP] (I S A -) submenu is used to display the value of the 8 communication scanner input variables [Com Scan In● val.] (NM●).
- The [COM SCAN OUTPUT MAP] (O S A -) submenu is used to display the value of the 8 communication scanner output variables [Com Scan Out● val.] (NC●).

Input variable	Scanner parameter	Output variable	Scanner parameter
No. 1	[Com Scan In1 val.] (NM1)	No. 1	[Com Scan Out1 val.] (NC1)
No. 2	[Com Scan In2 val.] (NM2)	No. 2	[Com Scan Out2 val.] (NC2)
No. 3	[Com Scan In3 val.] (NM3)	No. 3	[Com Scan Out3 val.] (NC3)
No. 4	[Com Scan In4 val.] (NM4)	No. 4	[Com Scan Out4 val.] (NC4)
No. 5	[Com Scan In5 val.] (NM5)	No. 5	[Com Scan Out5 val.] (NC5)
No. 6	[Com Scan In6 val.] (NM6)	No. 6	[Com Scan Out6 val.] (NC6)
No. 7	[Com Scan In7 val.] (NM7)	No. 7	[Com Scan Out7 val.] (NC7)
No. 8	[Com Scan In8 val.] (NM8)	No. 8	[Com Scan Out8 val.] (NC8)

Configuration of these variables is described in the "Configuration" section.

Example of communication scanner display on the graphic display terminal:

RUN	NET	+50.00Hz	80A
COM. SCANNER INPUT MAP <input type="checkbox"/>			
Com Scan In1 val.	:		34359
Com Scan In2 val.	:		600
Com Scan In3 val.	:		0
Com Scan In4 val.	:		0
Com Scan In5 val.	:		0
Code		Quick	<input checked="" type="checkbox"/>
Com Scan In6 val.	:		0
Com Scan In7 val.	:		0
Com Scan In8 val.	:		0

RUN	NET	+50.00Hz	80A
COM SCAN OUTPUT MAP <input type="checkbox"/>			
Com Scan Out1 val.	:		15
Com Scan Out2 val.	:		598
Com Scan Out3 val.	:		0
Com Scan Out4 val.	:		0
Com Scan Out5 val.	:		0
Code		Quick	<input checked="" type="checkbox"/>
Com Scan Out6 val.	:		0
Com Scan Out7 val.	:		0
Com Scan Out8 val.	:		0

In this example, only the first two variables have been configured (default assignment).

- [Com Scan In1 val.] = [34343] Status word = 34359 = 16#8637 → Drivecom "Operation enabled" state, reverse operation, speed reached
- [Com Scan In2 val.] = [600] Output speed = 600 → 600 rpm
- [Com Scan Out1 val.] = [15] Control word = 15 = 16#000F → "Enable operation" (Run) command
- [Com Scan Out2 val.] = [598] Speed reference = 600 → 598 rpm

7. Diagnostics

7. 5. Communication fault

Modbus communication faults are indicated by the red ERR LED on the Modbus card.

In the factory configuration, a communication fault will trigger a resettable [Com. network] (C n F) drive fault and initiate a freewheel stop.

It is possible to change the response of the drive in the event of a Modbus communication fault (see the Configuration section).

- [Com. network] (C n F) drive fault (freewheel stop, stop on ramp, fast stop or DC injection braking stop)
- No drive fault (stop, maintain, fallback)

The Parameters Manual contains a detailed description of how to manage communication faults (see the "Communication monitoring" section).

- Following initialization (power-up), the drive checks that at least one command or reference parameter has been written for the first time by Modbus.
- Then, if a communication fault occurs on Modbus, the drive will react according to the configuration (fault, maintain, fallback, etc.).

7. 6. Card fault

The [internal com. link] (I L F) fault appears when the following serious problems occur:

- Hardware fault on the Modbus card
- Dialog fault between the Modbus card and the drive

The response of the drive in the event of an [internal com. link] (I L F) fault cannot be configured, and the drive trips with a freewheel stop. This fault cannot be reset.

Two diagnostic parameters can be used to obtain more detailed information about the origin of the [internal com. link] (I L F) fault:

- [Internal link fault 1] (I L F 1) if the fault has occurred on option card no. 1 (installed directly on the drive)
- [Internal link fault 2] (I L F 2) if the fault has occurred on option card no. 2 (installed on option card no. 1)

The Modbus card can be in position 1 or 2.

The [Internal link fault 1] (I L F 1) and [Internal link fault 2] (I L F 2) parameters can only be accessed on the graphic display terminal in the [1.10 DIAGNOSTICS] (D G E -) menu, [MORE FAULT INFO] (A F I -) submenu.

Value	Description of the values of the [Internal link fault 1] (I L F 1) and [Internal link fault 2] (I L F 2) parameters
0	No fault
1	Loss of internal communication with the drive
2	Hardware fault detected
3	Error in the EEPROM checksum
4	Faulty EEPROM
5	Faulty Flash memory
6	Faulty RAM memory
7	Faulty NVRAM memory
8	Faulty analog input
9	Faulty analog output
10	Faulty logic input
11	Faulty logic output
101	Unknown card
102	Exchange problem on the drive internal bus
103	Time out on the drive internal bus (500 ms)

8. Modbus protocol

8. 1. Principle

The Modbus protocol is a master-slave protocol.

Only one device can transmit on the line at any one time.

The master manages the exchanges and only it can take the initiative.

It interrogates each of the slaves in succession.

No slave can send a message unless it is invited to do so.

In the event of an error during data exchange, the master repeats the question and declares the interrogated slave absent if no response is received within a given time period.

If a slave does not understand a message, it sends an exception response to the master.
The master may or may not repeat the request.

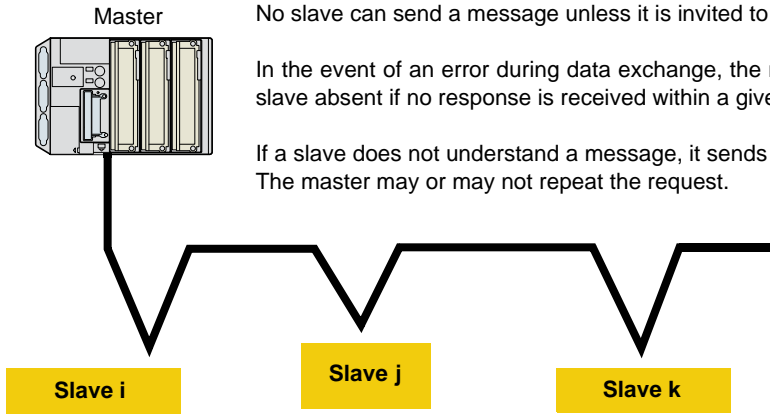

Direct slave-to-slave communications are not possible.

For slave-to-slave communication, the master's application software must therefore be designed to interrogate one slave and send back data received to the other slave.

Two types of dialog are possible between master and slaves:

- The master sends a request to a slave and waits for it to respond.
- The master sends a request to all slaves without waiting for them to respond (broadcasting principle).

Note: The Modbus server on the "Controller Inside" card cannot be accessed via the Modbus card.

8. Modbus protocol

8.2. Modes

■ RTU mode

The Modbus RTU frame contains no message header byte, nor end of message bytes. It is defined as follows:



The data is transmitted in binary code.

CRC16: Cyclic redundancy check parameter.

The end of the frame is detected on a silence greater than or equal to 3.5 characters.

The format used for the frames in the rest of this document is RTU mode.

■ ASCII mode

The structure of the Modbus ASCII frame is as follows:

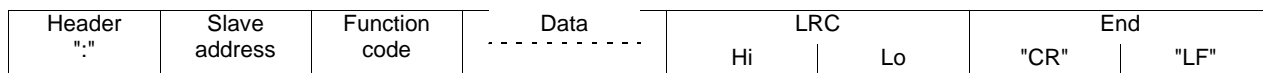

Header: By default, ":" = 16#3A. Two other characters are possible: "CR" = 16#0D and "LF" = 16#0A.

LRC: The 2's-complement of the modulo 256 sum (in hexadecimal format) of the frame (excluding the header and end characters) before ASCII coding.

Example: Write a value of 10 to logic address word 9001 (16#2329) on slave 2

Identical request and response:

In hexadecimal format

3A	30	32	30	36	32	33	32	39	30	30	30	41	41	32	0D	0A
----	----	----	----	----	----	----	----	----	----	----	----	----	----	----	----	----

In ASCII format

:	0	2	0	6	2	3	2	9	0	0	0	A	A	2	CR	LF
---	---	---	---	---	---	---	---	---	---	---	---	---	---	---	----	----

8. Modbus protocol

8.3. Modbus functions available

The following table indicates which Modbus functions are managed by the Altivar 71 and specifies their limits. The "read" and "write" functions are defined from the point of view of the master.

Code	Modbus name	Description	Broadcast	Size of data
3 = 16#03	Read Holding Registers	Read N output words	NO	63 words, max.
4 = 16#04	Read Input Registers	Read N input words	NO	63 words, max.
6 = 16#06	Write Single Register	Write one output word	YES	
8 = 16#08	Diagnostics	Diagnostics	NO	
11 = 16#0B	Get Comm Event Counter	Read counter	NO	
16 = 16#10	Write Multiple Registers	Write N output words	YES	61 words, max.
23 = 16#17	Read/Write Multiple Registers	Read/write N words	NO	20/20 words max.
43 = 16#2B	Read Device Identification	Identification	NO	

8.4. Read Holding/Input Registers (3/4)

Functions 3 and 4 access all the drive registers that make no distinction between the "Holding" or "Input" types.

Request:

Slave no.	03/04	No. of first word Hi Lo	Number of words Hi Lo	CRC16 Lo Hi
1 byte	1 byte	2 bytes	2 bytes	2 bytes

Response:

Slave no.	03/04	Number of bytes read	First word value Hi Lo	-----	Last word value Hi Lo	CRC16 Lo Hi
1 byte	1 byte	1 byte	2 bytes		2 bytes	2 bytes

Example: Use function 3 to read 4 logic address words 3102 to 3105 (16#0C1E to 16#0C21) on slave 2, where:

- SFr = Switching frequency = 4 kHz (logic address 3102 = 16#0028)
- tFr = Maximum output frequency = 60 Hz (logic address 3103 = 16#0258)
- HSP = High speed = 50 Hz (logic address 3104 = 16#01F4)
- LSP = Low speed = 0 Hz (logic address 3105 = 16#0000)

Request:

02	03	0C1E	0004	276C
----	----	------	------	------

Response:

02	03	08	0028	0258	01F4	0000	52B0
Value of:			3102	3103	3104	3105	
Parameter code:			SFr	tFr	HSP	LSP	

8. Modbus protocol

8. 5. Write Single Register (6)

Request and response:

Slave no.	06	Word number		Value of word		CRC16	
		Hi	Lo	Hi	Lo	Lo	Hi
1 byte	1 byte	2 bytes		2 bytes		2 bytes	

Example: Write value 16#000D to logic address word 9001 (16#2329) on slave 2 (ACC = 13 s)

Request and response:

02	06	2329	000D	9270
----	----	------	------	------

8. Modbus protocol

8. 6. Diagnostics (8)

Request and response:

Slave no.	08	Sub-code		Data		CRC16	
		Hi	Lo	Hi	Lo	Hi	Lo
1 byte	1 byte	2 bytes		2 bytes		2 bytes	

Sub code	Function	Request data	Response data
00	Echo This function asks the slave to return the request sent by the master. The size of the data is limited to 2 bytes.	XX YY	XX YY
01	Reinitialize channel This function is used to reinitialize slave communication and, in particular, to make it exit listen only mode (LOM).	16#00 00 or 16#FF 00	16#00 00 or 16#FF 00
03	Change ASCII delimiter In ASCII mode, messages are delimited by the line feed character (LF = H'0A). This function is used to change this character.	XX 00 XX = new delimiter	XX 00
04	Change to LOM mode This function is used to force a slave to listen only mode (LOM). In this mode, the slave does not handle messages which are addressed to it, nor does it send any responses, except when the channel is reinitialized.	00 00	00 00
0A	Counter reset This function resets all the counters responsible for monitoring slave exchanges.	00 00	00 00
0B	Read the number of correct messages on the line without checksum error	00 00	Value of counter
0C	Read the number of incorrect messages on the line with checksum error	00 00	Value of counter
0D	Read the number of exception responses sent by the slave	00 00	Value of counter
0E	Read the number of messages addressed to the slave excluding broadcast messages regardless of type	00 00	Value of counter
0F	Read the number of broadcast messages on the line regardless of type	00 00	Value of counter
10	Read the number of NAK exception responses The value read is always 0.	00 00	00 00
11	Read the number of slave not ready responses The value read is always 0.	00 00	00 00
12	Read the number of messages received with character overrun	00 00	Value of counter

The counters are unsigned words.

Example: Values 16#31 and 16#32 echoed by slave 4

Request and response:

Slave no.	Code	Subcode		Value of 1 st byte	Value of 2 nd byte	CRC Lo	CRC Hi
		Hi	Lo				
04	08	00	00	31	32	74	1B

8. Modbus protocol

8. 7. Get Comm Event Counter (11 = 16#0B)

Question:

Slave no.	0B	CRC16
1 byte	1 byte	2 bytes

Response:

Slave no.	0B	00	00	Value of counter	CRC16
1 byte	1 byte	2 bytes		Hi Lo	Lo Hi
				2 bytes	2 bytes

8. 8. Write Multiple Registers (16 = 16#10)

Request:

Slave no.	10	No. of first word	Number of words	Number of bytes	Value of first word	-----	CRC16
1 byte	1 byte	Hi Lo	Hi Lo	1 byte	Hi Lo		Lo Hi
		2 bytes	2 bytes		2 bytes		2 bytes

Response:

Slave no.	10	No. of first word	Number of words	CRC16
1 byte	1 byte	Hi Lo	Hi Lo	Lo Hi
		2 bytes	2 bytes	2 bytes

Example: Write values 20 and 30 to logic address words 9001 and 9002 on slave 2 (acceleration time = 20 s and deceleration time = 30 s)

Request:

Slave no.	Request code	No. of first word		Number of words		Number of bytes	Value of first word		Value of second word		CRC16	
		Hi	Lo	Hi	Lo		Hi	Lo	Hi	Lo	Lo	Hi
02	10	23	29	00	02	04	00	14	00	1E	73	A4

Response:

Slave no.	Response code	No. of first word		Number of words		CRC16	
		Hi	Lo	Hi	Lo	Lo	Hi
02	10	23	29	00	02	9B	B7

8. Modbus protocol

8. 9. Read/Write Multiple Registers (23 = 16#17)

Request:

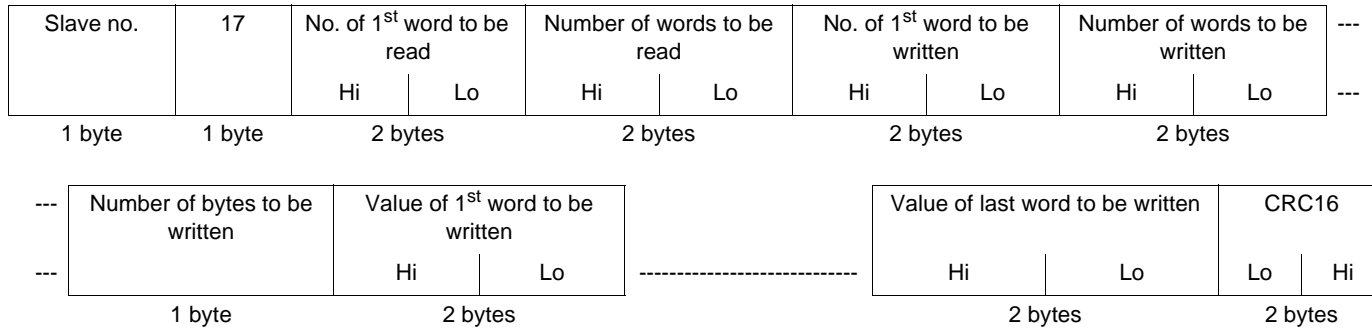

Response:

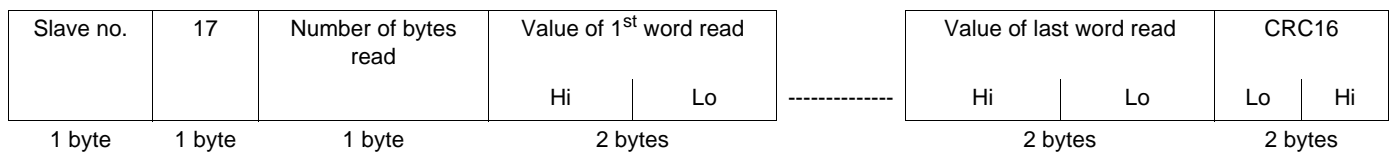

Example: This example combines the two examples for functions 3 and 16. With function 23, the line is less busy than with these two functions. However, the number of words that can be read and written is restricted.

- Write the values 20 (16#14) and 30 (16#1E) respectively to the 2 logic address words 9001 and 9002 on slave 2.
- Read the 4 logic address words 3102 to 3105 on the same slave (values read = 16#0028, 16#0258, 16#01F4, and 16#0000).

Request:

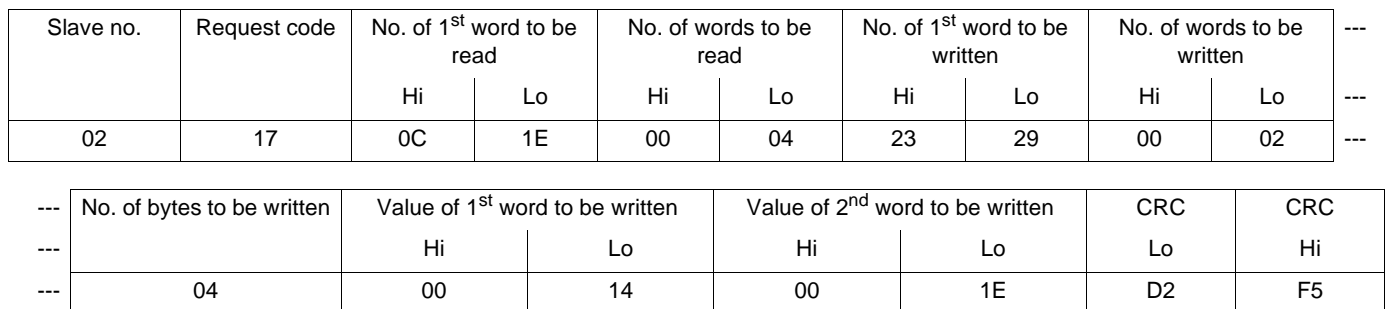

Response:

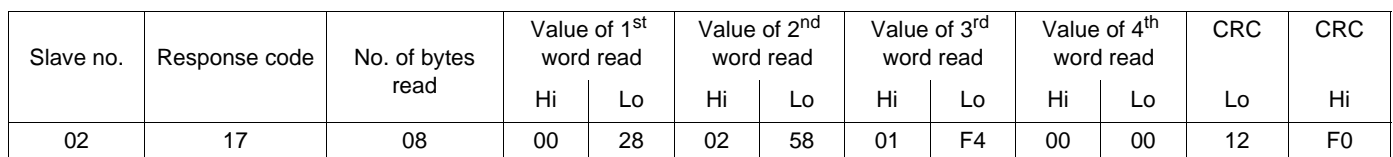

8. Modbus protocol

8. 10. Read Device Identification (43 = 16#2B)

Request:

Slave no.	2B	Type of MEI 0E	ReadDeviceld 01	Object Id 00	CRC16	
1 byte	1 byte	1 byte	1 byte	1 byte	Lo	Hi
					2 bytes	

Response:

Slave no.	2B	Type of MEI 0E	ReadDeviceld 01	Degree of conformity 02	-----
1 byte	1 byte	1 byte	1 byte	1 byte	
-----		Number of additional frames 00		Next object Id 00	Number of objects 04
		1 byte	1 byte	1 byte	-----
-----		Id of object no. 1 00+	Length of object no. 1 0D	Value of object no. 1 "Telemecanique"	
		1 byte	1 byte	13 bytes	
-----		Id of object no. 2 01	Length of object no. 2 0B	Value of object no. 2 "ATV71HU15M3"	
		1 byte	1 byte	11 bytes	
-----		Id of object no. 3 02	Length of object no. 3 04	Value of object no. 3 "0201"	
		1 byte	1 byte	4 bytes	
-----		Id of object no. 4 06	Length of object no. 4 09	Value of object no. 4 "MACHINE 4"	
		1 byte	1 byte	9 bytes	
-----		CRC16			
		Lo	Hi		
		1 byte	1 byte		

The total response size given in this example equals 55 bytes.

The response contains the following four objects:

- Object no. 1: Manufacturer name (always "Telemecanique", i.e., 13 bytes).
- Object no. 2: Device catalog number (ASCII string; for example: "ATV71HU15M3", i.e., 11 bytes). The length of this object varies according to drive type. Use the "Length of object no. 2" field to determine the length.
- Object no. 3: Device version, in "MMmm" format where "MM" represents the determinant and "mm" the subdeterminant (4-byte ASCII string; for example: "0201" for version 2.1).
- Object no. 4: Device name (ASCII string; for example: "MACHINE 4", i.e., 9 bytes). The length of this object varies according to the device name assigned to the drive (the latter being configured by the user): [\[7. DISPLAY CONFIG.\]](#) menu, [\[7.1 USER PARAMETERS\]](#) submenu, [\[DEVICE NAME\]](#) parameter. This menu can only be accessed in Expert mode. Maximum size 16 bytes.

8. Modbus protocol

Negative response specifically related to the identification function:

Slave no.	2B + 80 AB	Type of MEI 0E	Error code 00 to 02	CRC16	
				Lo	Hi
1 byte	1 byte	1 byte	1 byte	1 byte	1 byte

Error code: 16#00 = No error
 16#01 = The "Request code" (16#2B), the "Type of MEI" (16#0E) or the "ReadDeviceId" (16#01) contained in the request is incorrect.
 16#02 = The "Object Id" (16#00) contained in the request is incorrect.

Example of positive response:

- Address = 2
- Manufacturer name = "Telemecanique"
- Device name = "ATV71HU15M3"
- Device version = "0201"
- Device name = "MACHINE 4"

Request:

Slave no.	Request code	Type of MEI	ReadDeviceId	Object Id	CRC Lo	CRC Hi
02	2B	0E	01	00	34	77

Response:

Slave no.	Response code	Type of MEI	ReadDeviceId	Degree of conformity	No. of additional frames	Next object Id	Object no.
02	2B	0E	01	02	00	00	04

Id of object no.	Length of object no. 1	Value of object no. 1												
		'T'	'e'	'l'	'e'	'm'	'e'	'c'	'a'	'n'	'i'	'q'	'u'	'e'
00	0D	54	65	6C	65	6D	65	63	61	6E	69	71	75	65

Id of object no.	Length of object no. 2	Value of object no. 2										
		'A'	'T'	'V'	'7'	'1'	'H'	'U'	'1'	'5'	'M'	'3'
01	0B	41	54	56	37	31	48	55	31	35	4D	33

Id of object no.	Length of object no. 3	Value of object no. 3			
		'0'	'2'	'0'	'1'
02	04	30	32	30	31

Id of object no.	Length of object no. 4	Value of object no. 4									CRC Lo	CRC Hi
		'M'	'A'	'C'	'H'	'l'	'N'	'E'	' '	'4'		
06	09	4D	41	43	48	49	4E	45	20	34	6F	50

8. Modbus protocol

8. 11. Communication scanner

The communication scanner can be used to enhance application performance. The drive automatically copies non-contiguous parameters to an input table and an output table. Thus, the copy of several non-contiguous parameters can be read or written in a single request (an operation which would normally have required several Modbus requests).

The input table and the output table each contain 8 variables.

Output variables	Logic address	Default assignment
[Com Scan Out1 val.] (n C 1)	12 761 = 16#31D9	Control word (CMd)
[Com Scan Out2 val.] (n C 2)	12 762 = 16#31DA	Speed reference (LFrd)
[Com Scan Out3 val.] (n C 3)	12 763 = 16#31DB	Not used
[Com Scan Out4 val.] (n C 4)	12 764 = 16#31DC	Not used
[Com Scan Out5 val.] (n C 5)	12 765 = 16#31DD	Not used
[Com Scan Out6 val.] (n C 6)	12 766 = 16#31DE	Not used
[Com Scan Out7 val.] (n C 7)	12 767 = 16#31DF	Not used
[Com Scan Out8 val.] (n C 8)	12 768 = 16#31E0	Not used

Input variables	Logic address	Default assignment
[Com Scan In1 val.] (n P 1)	12 741 = 16#31C5	Status word (EtA)
[Com Scan In2 val.] (n P 2)	12 742 = 16#31C6	Output speed (rFrd)
[Com Scan In3 val.] (n P 3)	12 743 = 16#31C7	Not used
[Com Scan In4 val.] (n P 4)	12 744 = 16#31C8	Not used
[Com Scan In5 val.] (n P 5)	12 745 = 16#31C9	Not used
[Com Scan In6 val.] (n P 6)	12 746 = 16#31CA	Not used
[Com Scan In7 val.] (n P 7)	12 747 = 16#31CB	Not used
[Com Scan In8 val.] (n P 8)	12 748 = 16#31CC	Not used

The values of these communication scanner variables can be displayed on the graphic display terminal using the [1.2-MONITORING] menu, [COMMUNICATION MAP] (C P P) submenu (see section "7. Diagnostics - 7.4 Communication scanner").

These parameters can be accessed via all the read and write requests supported by the drive. There is a marked improvement in performance for the following functions:

Code	Modbus name	Description	Size of data
3 = 16#03	Read Holding Registers	Read N output words	63 words, max.
4 = 16#04	Read Input Registers	Read N input words	63 words, max.
16 = 16#10	Write Multiple Registers	Write N output words	61 words, max.
23 = 16#17	Read/Write Multiple Registers	Read/write N words	20/20 words max.
43 = 16#2B	Read Device Identification	Identification	

8. Modbus protocol

The link between the drive parameters and the communication scanner variables can be made:

- Via the display terminal (see section "6. Configuration - 6.2 Communication scanner")
- Via Modbus: Before starting the application, the PLC must first write the address tables described below.

Output variable address	Logic address	Default value
[Scan.Out1 address] (n C A 1)	12 721 = 16#31B1	8501 = 16#2135
[Scan.Out2 address] (n C A 2)	12 722 = 16#31B2	8602 = 16#219A
[Scan.Out3 address] (n C A 3)	12 723 = 16#31B3	0
[Scan.Out4 address] (n C A 4)	12 724 = 16#31B4	0
[Scan.Out5 address] (n C A 5)	12 725 = 16#31B5	0
[Scan.Out6 address] (n C A 6)	12 726 = 16#31B6	0
[Scan.Out7 address] (n C A 7)	12 727 = 16#31B7	0
[Scan.Out8 address] (n C A 8)	12 728 = 16#31B8	0

Input variable address	Logic address	Default value
[Scan.IN1 address] (n P A 1)	12 701 = 16#319D	3201 = 16#0C8B
[Scan.IN2 address] (n P A 2)	12 702 = 16#319E	8604 = 16#219C
[Scan.IN3 address] (n P A 3)	12 703 = 16#319F	0
[Scan.IN4 address] (n P A 4)	12 704 = 16#31A0	0
[Scan.IN5 address] (n P A 5)	12 705 = 16#31A1	0
[Scan.IN6 address] (n P A 6)	12 706 = 16#31A2	0
[Scan.IN7 address] (n P A 7)	12 707 = 16#31A3	0
[Scan.IN8 address] (n P A 8)	12 708 = 16#31A4	0

Example

- Use of the "Read/Write Multiple Registers" function (request code: 23 = 16#17)
- Transmission of the request to a drive located at address 20 (16#14)
- Reading all 8 scanner input variables
- List of source parameters:

No.	Parameter	Logic address	Read value
1	Status word (EtA)	3201	16#0007
2	Output speed (rFrd)	8604	16#1388
3	Motor current (LCr)	3204	16#0064
4	Output torque (Otr)	3205	16#0045

No.	Parameter	Logic address	Read value
5	Power section AC supply voltage (ULn)	3207	16#00F0
6	Drive thermal state (tHd)	3209	16#0065
7	Motor thermal state (tHr)	9630	16#0032
8	Altivar fault code (LFt)	7121	16#0000

- Writing the first 6 scanner output variables
- List of target parameters:

No.	Parameter	Logic address	Value to be written
1	Control word (CMd)	8501	16#000F
2	Speed reference (LFrd)	8602	16#1388
3	High speed (HSP)	3104	16#1F40
4	Low speed (LSP):	3105	16#01F4

No.	Parameter	Logic address	Value to be written
5	[Acceleration] (ACC)	9001	16#04B0
6	[Deceleration] (dEC)	9002	16#0258
7	-	0	16#0000
8	-	0	16#0000

8. Modbus protocol

The communication scanner is configured via the display terminal as follows:

Output (control):

Configuration parameter	Value	Parameter assigned
[Scan. Out1 address] (n C A 1)	8501	Control word (CMd)
[Scan. Out2 address] (n C A 2)	8602	Speed reference (LFrd)
[Scan. Out3 address] (n C A 3)	3104	[High speed] (HSP)
[Scan. Out4 address] (n C A 4)	3105	[Low speed] (LSP):
[Scan. Out5 address] (n C A 5)	9001	[Acceleration] (ACC)
[Scan. Out6 address] (n C A 6)	9002	[Deceleration] (dEC)
[Scan. Out7 address] (n C A 7)	0	Not used
[Scan. Out8 address] (n C A 8)	0	Not used

Input (monitoring):

Configuration parameter	Value	Parameter assigned
[Scan. IN1 address] (n P A 1)	3201	Status word (EtA)
[Scan. IN2 address] (n P A 2)	8604	Output speed (rFrd)
[Scan. IN3 address] (n P A 3)	3204	[Motor current] (LCr)
[Scan. IN4 address] (n P A 4)	3205	[Output torque] (Otr)
[Scan. IN5 address] (n P A 5)	3207	[Power section AC supply voltage] (ULn)
[Scan. IN6 address] (n P A 6)	3209	[Drive thermal state] (tHd)
[Scan. IN7 address] (n P A 7)	9630	[Motor thermal state] (tHr)
[Scan. IN8 address] (n P A 8)	7121	Altivar fault code (LFt)

Request:

Slave no.	Request code	No. of 1 st word to be read		No. of words to be read		No. of 1 st word to be written		No. of words to be written		No. of bytes to be written
		Hi	Lo	Hi	Lo	Hi	Lo	Hi	Lo	
14	17	31	C5	00	08	31	D9	00	06	0C

Value of 1 st word to be written		Value of 2 nd word to be written		Value of 3 rd word to be written		Value of 4 th word to be written		Value of 5 th word to be written		Value of 6 th word to be written		CRC	CRC
Hi	Lo	Hi	Lo	Hi	Lo	Hi	Lo	Hi	Lo	Hi	Lo		
00	0F	13	88	1F	40	01	F4	04	B0	02	58	56	3D

Response:

Slave no.	Response code	No. of bytes read	Value of 1 st word read		Value of 2 nd word read		Value of 3 rd word read		Value of 4 th word read	
			Hi	Lo	Hi	Lo	Hi	Lo	Hi	Lo
14	17	10	00	07	13	88	00	64	00	45

Value of 5 th word read		Value of 6 th word read		Value of 7 th word read		Value of 8 th word read		CRC	CRC
Hi	Lo	Hi	Lo	Hi	Lo	Hi	Lo		
00	F0	00	65	00	32	00	00	E4	90

8. Modbus protocol

8. 12. Exception responses

An exception response is returned by a slave when it is unable to perform the request which is addressed to it.

Format of an exception response:

Slave no.	Response code	Error code	CRC16	
			Lo	Hi
1 byte	1 byte	1 byte	2 bytes	

Response code: request code + H'80.

Error code:

- 1 = The function requested is not recognized by the slave.
- 2 = The addresses indicated in the request do not exist in the slave.
- 3 = The values indicated in the request are not permitted on the slave.
- 4 = The slave has started to execute the request but cannot continue to process it completely.
- 6 = The requested write operation has been refused because the drive is in "Forced local" mode.
- 7 = The requested write operation has been refused because the motor is running (configuration parameters).

Example: Writing the value 1 to the status word (EtA) = logic address 3201 (which cannot be written, because in "read-only" mode) on slave 4

Request:

Slave no.	Request code	No. of 1 st word		No. of words		No. of bytes	Value of 1 st word		CRC Lo	CRC Hi
		Hi	Lo	Hi	Lo		Hi	Lo		
4	10	0C	81	00	01	02	00	01	8A	D1

Response:

Slave no.	Response code	Error code	CRC Lo	CRC Hi
4	90	00	5C	01

8. Modbus protocol

8.13. Read non-existent or protected parameters

If a set of parameters is read using a Modbus function, the value returned for non-existent and protected parameters is equal to 16#8000.

If the same Modbus function is used to read parameters, all of which are non-existent or protected, the drive sends back an exception response with an error code equal to 2.

Example of non-existent or protected parameters being read:

In this example, the same request to read a non-existent parameter followed by 2 existing parameters is used several times in a row in order to demonstrate the effects of parameter protection.

The "Read Holding Registers" request (3) is addressed to a drive with a Modbus address of 12 (16#0C). The read operation is performed for 3 consecutive words, starting with address 8400.

Logic address	Parameter	Value
8400 = 16#20FA	Non-existent	-
8401 = 16#20D1	[Profile] (CHCF)	3
8402 = 16#20D2	[Copy channel 1 ↔ 2] (COP)	2

Request:

Slave no.	Request code	No. of 1st word		No. of words		CRC16	
		Hi	Lo	Hi	Lo	Lo	Hi
0C	03	20	D0	00	03	0E	EF

Response:

Scenario no. 1: Parameters CHCF (8401) and COP (8402) not protected → Successful reading of these two parameters and value equal to 16#8000 for the non-existent parameter located at address 8400.

Slave no.	Response code	No. of bytes read	Value 8400		Value 8401		Value 8402		CRC16	
			Hi	Lo	Hi	Lo	Hi	Lo	Lo	Hi
0C	03	06	80	00	00	03	00	02	17	E4

Scenario no. 2: Parameter CHCF (8401) protected and COP (8402) not protected → Successful reading of COP and value equal to 16#8000 for the non-existent parameter located at address 8400 and for parameter CHCF.

Slave no.	Response code	No. of bytes read	Value 8400		Value 8401		Value 8402		CRC16	
			Hi	Lo	Hi	Lo	Hi	Lo	Lo	Hi
0C	03	06	80	00	80	00	00	02	CE	24

Scenario no. 3: Parameters CHCF (8401) and COP (8402) protected → Exception response (response code = 16#80 + request code), as all the parameters read are either non-existent, or protected; error code equal to 2 (the word addresses indicated in the request do not exist in the slave).

Slave no.	Response code	Error code	CRC16	
			Lo	Hi
0C	80+03 = 83	02	51	32

9. Appendix

9. 1. RS485 standard

The RS485 standard (ANSI/TIA/EIA-485-A-1998) allows variants of certain characteristics:

- Polarization
- Line termination
- Distribution of a reference potential
- Number of slaves
- Length of bus

It does not specify the connector type or pinout.

The Modbus specification published on www.modbus.org in 2002 contains precise details of all these characteristics. They are also summarized in the next sections (Modbus 2-wire and 4-wire standard schematics). The latest generation Telemecanique devices (Altivar 31, Altivar 71, etc.) conform to this specification.

Older devices comply with earlier specifications. The two most widespread are described in the following sections:

- "Uni-Telway schematic" page [42](#)
- "Jbus schematic" page [43](#)

Requirements enabling different types of protocol to coexist are given in the following section in this appendix:

- "Creating a Modbus bus using non-standard equipment" on page [45](#)

9. Appendix

9. 2. Modbus 2-wire standard schematic

The standard schematic corresponds to the Modbus specification published in 2002 on www.modbus.org (Modbus_over_serial_line_V1.pdf, Nov 2002) and, in particular, to the 2-wire multipoint serial bus schematic.

The Modbus card (VW3 A3 303) conforms to this specification.

Schematic diagram:

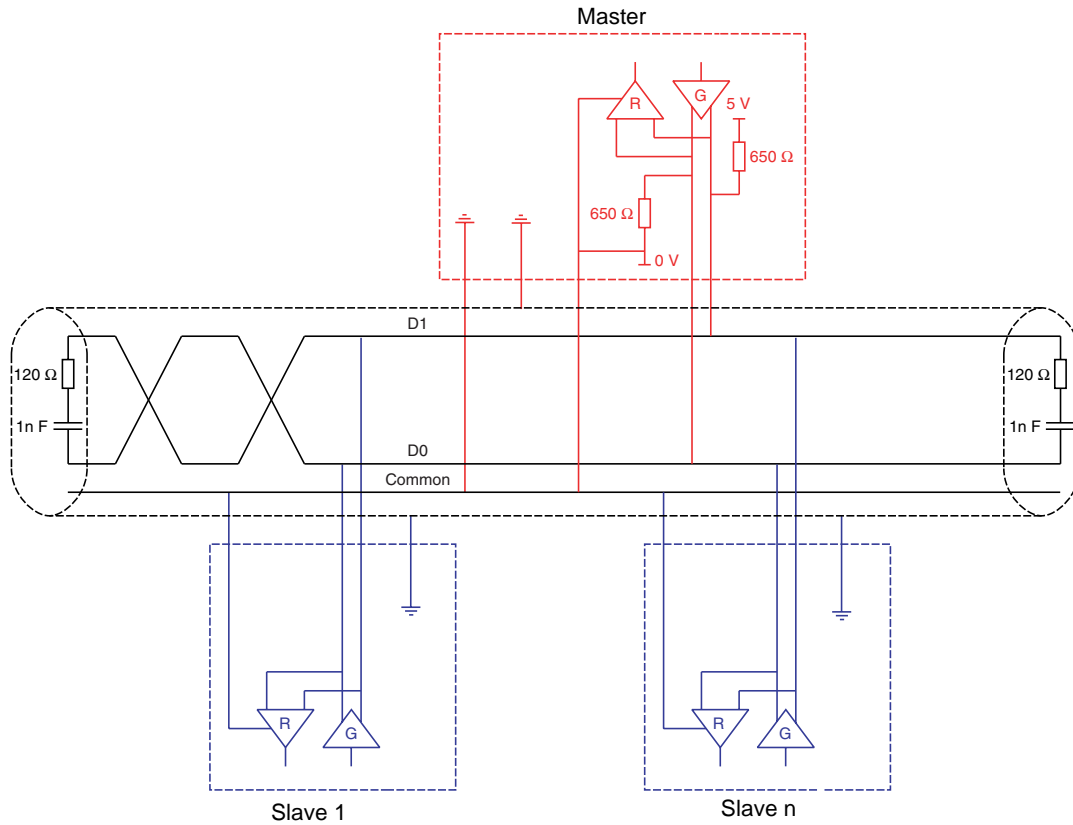

Type of trunk cable	Shielded cable with 1 twisted pair and at least a 3 rd conductor
Maximum length of bus	1000 m at 19200 bps with the Telemecanique TSX CSA●00 cable
Maximum number of stations (without repeater)	32 stations, i.e., 31 slaves
Maximum length of tap links	<ul style="list-style-type: none"> • 20 m for one tap link • 40 m divided by the number of tap links on a multiple junction box
Bus polarization	<ul style="list-style-type: none"> • One 450 to 650 Ω pull-up resistor to the 5 V (650 Ω or thereabouts recommended) • One 450 to 650 Ω pull-down resistor to the Common (650 Ω or thereabouts recommended) This polarization is recommended for the master.
Line termination	One 120 Ω 0.25 W resistor in series with a 1nF 10 V capacitor
Common polarity	Yes (Common), connected to the protective ground at one or more points on the bus

9. Appendix

9.3. Modbus 4-wire standard schematic

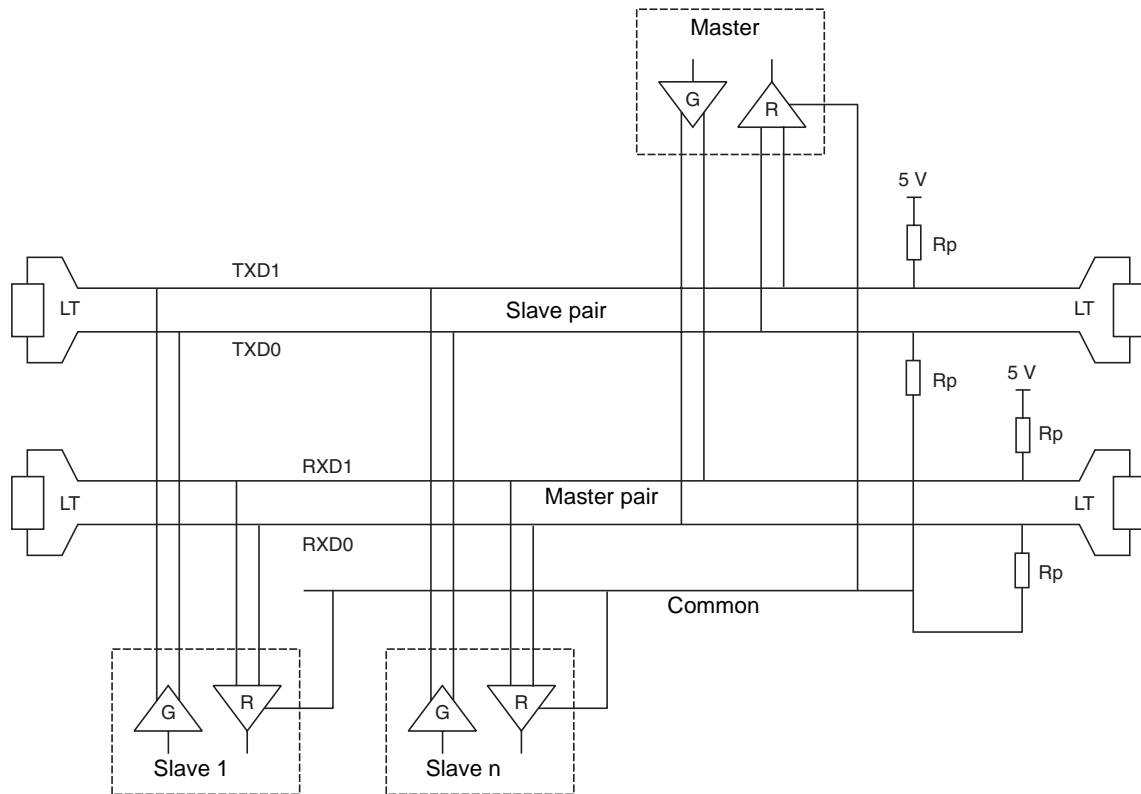

9. Appendix

9.4. Uni-Telway schematic

The Uni-Telway bus schematic was used by Telemecanique for older-generation drives and soft starters (ATV58, ATV28, ATS48, etc.) marketed before the Modbus specifications were published on www.modbus.org.

Schematic diagram:

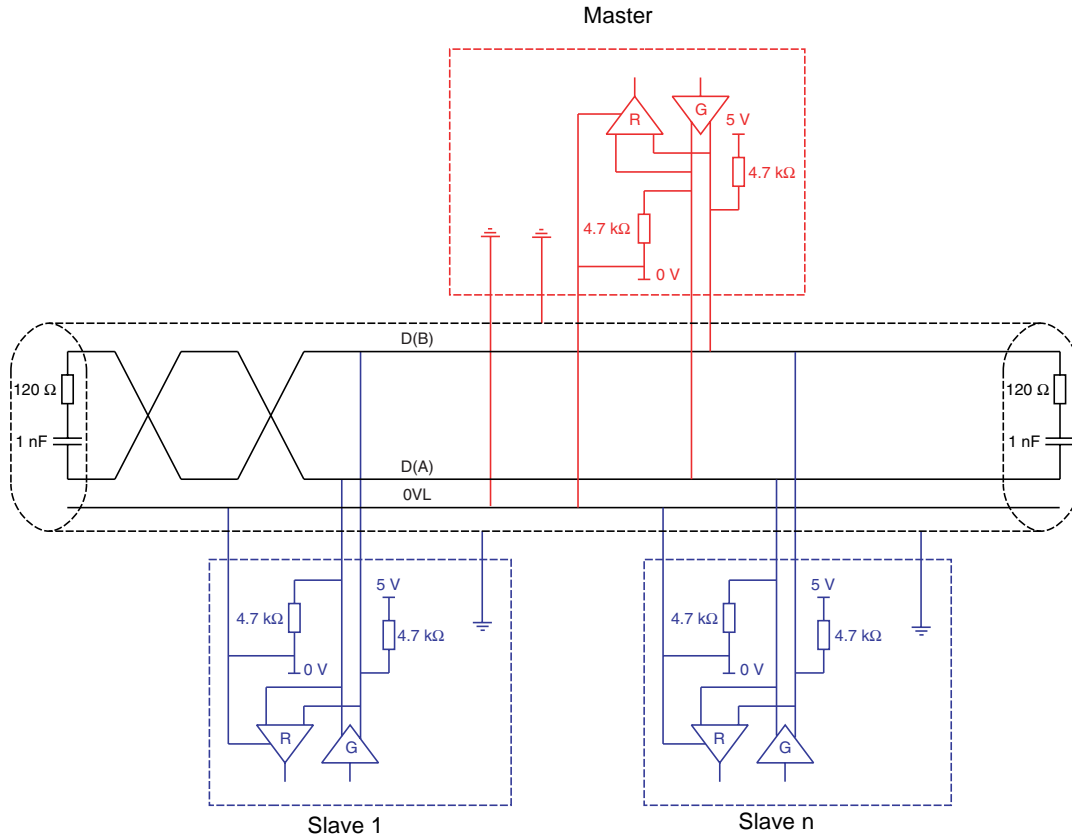

Type of trunk cable	Cable with 2 twisted pairs shielded in pairs
Maximum length of bus	1000 m at 19200 bps
Maximum number of stations (without repeater)	29 stations, i.e., 28 slaves
Maximum length of tap links	<ul style="list-style-type: none"> • 20 m • 40 m divided by the number of tap links on a multiple junction box
Bus polarization	For the master and each slave: <ul style="list-style-type: none"> • One 4.7 kΩ pull-up resistor to the 5 V • One 4.7 kΩ pull-down resistor to the 0 VL
Line termination	One 120 Ω 0.25 W resistor in series with a 1 nF 10 V capacitor
Common polarity	Yes (0 VL) and high impedance placed between 0 VL and the ground in each station

9. Appendix

9. 5. 2-wire Jbus schematic

Schematic diagram:

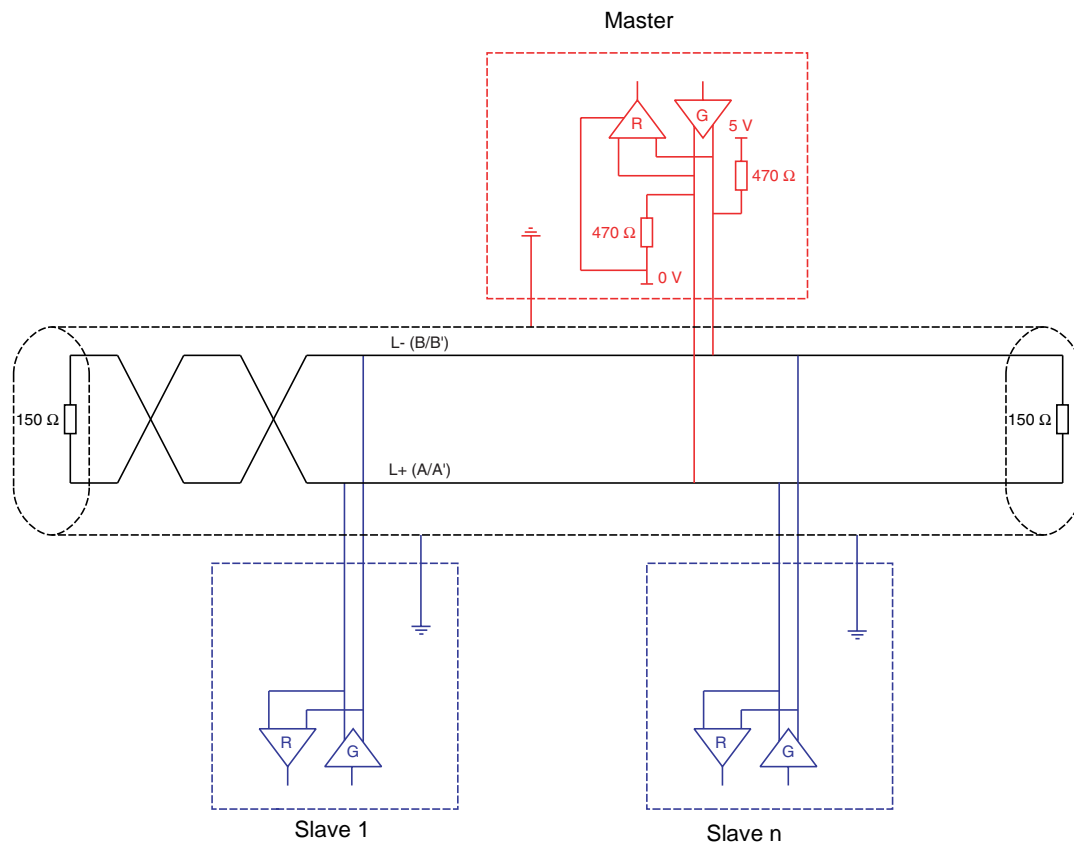

Type of trunk cable	Cable with 1 shielded twisted pair
Maximum length of bus	1,300 m at 19200 bps
Maximum number of stations (without repeater)	32 stations, i.e., 31 slaves
Maximum length of tap links	3 m
Bus polarization	One 470 Ω pull-up resistor to the 5 V One 470 Ω pull-down resistor to the 0 V This polarization is often provided in the master.
Line termination	One 150 Ω resistor
Common polarity	No

9. Appendix

9. 6. Creating a Modbus bus using non-standard equipment

■ Different scenarios

- If the Modbus bus is created using the latest-generation Telemecanique devices and Telemecanique Modbus wiring accessories, installation is simple and no calculation is required (see the section entitled "Connecting to the bus").
- If a new Modbus bus has to be created using devices of different brands or older-generation devices, which do not comply with the Modbus standard, several checks are required (see "Recommendations" below).
- If, on an existing Modbus bus, a device with 4.7 k Ω polarization is to be replaced by a new-generation device, set the 2 polarization switches to the lower position to activate the card's 4.7 k Ω polarization.

Polarization switches:



4.7 k Ω RS485 line polarization at drive level

■ Recommendations

1. Identify the polarities D0 and D1.

They are labeled in different ways depending on the standard:

	Standard			
	Modbus	EIA/TIA-485 (RS 485)	Uni-Telway	Jbus
Signals	D0	A/A'	D (A)	RD +/TD + or L +
	D1	B/B'	D (B)	RD -/TD - or L -
	Common	C/C'	0VL	
Generator	B	G		
Receiver	R	R		

However, certain RS485 electronic components are labeled in the opposite way to the EIA/TIA-485 standard. It may be necessary to perform a test by connecting a master to a slave, then reversing the connection in the event of failure.

2. Check polarizations

Check the documentation supplied with the devices to determine their polarization.

If there is a polarization, check that the equivalent polarization value is correct (see "Calculating the polarization").

It is not always possible to implement correct polarization (for example, if the 5 V is not available on the master). In this case, it may be necessary to limit the number of slaves.

3. Choose a line terminator

If there is a polarization, select an RC line terminator ($R = 120 \Omega$, $C = 1 \text{ nF}$)

If it is not possible to install a polarization, select an R line terminator ($R = 150 \Omega$).

9. Appendix

■ Calculating the polarization

□ Principle

You must ensure that the equivalent bus resistance is between 162 Ω and 650 Ω.

The equivalent bus resistance (R_e) depends on the polarization resistance of the slaves (R_s) and the master (R_m):

$$\frac{1}{R_e} = \frac{1}{R_m} + \frac{1}{R_{s_1}} + \frac{1}{R_{s_2}} + \dots$$

If R_e is too low, reduce the number of slaves.

If R_e is too high, adapt the master's polarization (if possible) or add polarization resistors (R_p).

$$\frac{1}{R_e} = \frac{1}{R_p} + \frac{1}{R_m} + \frac{1}{R_{s_1}} + \frac{1}{R_{s_2}} + \dots$$

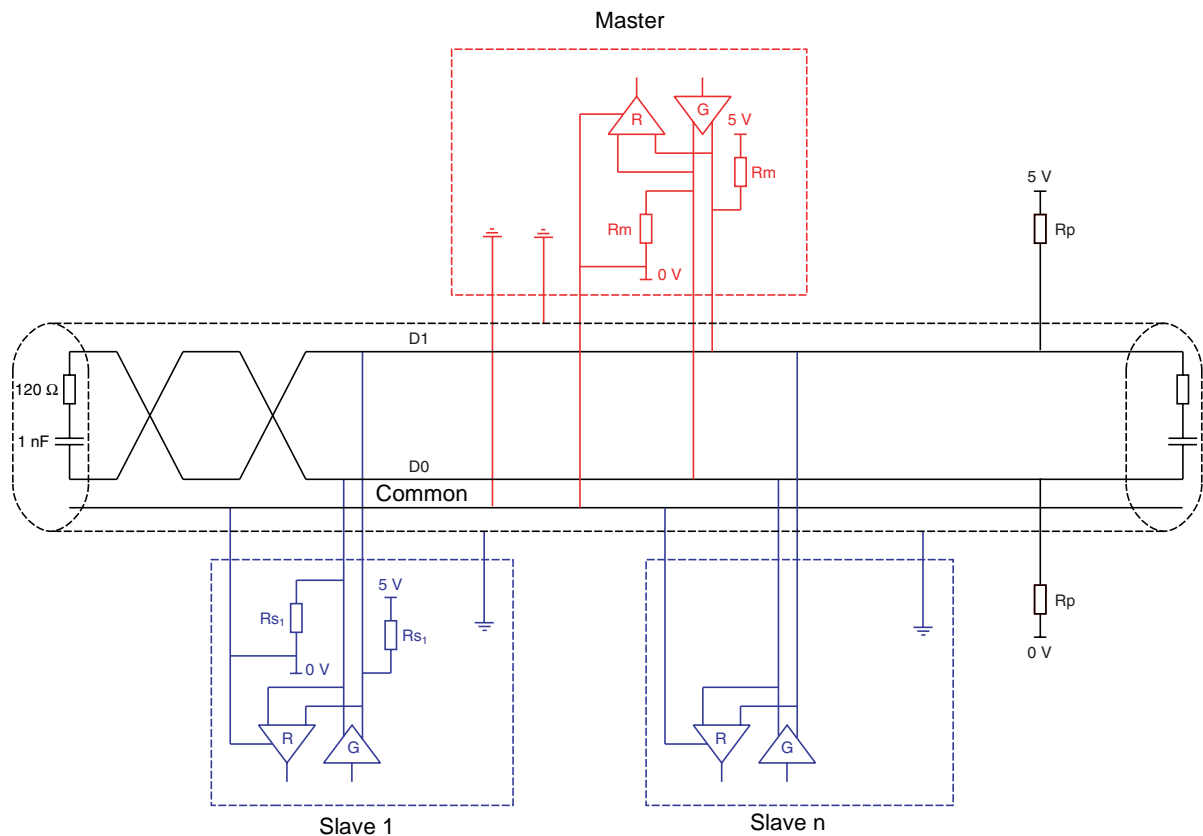

Example 1

If the master has 470 Ω polarization and all the slaves have 4.7 kΩ polarization, a maximum of 18 slaves can be connected.

$$R_m = 470 \Omega$$

$$R_s = 4.7 \text{ k}\Omega$$

$$1/R_e = 1/470 + 18 \times 1/4700$$

$$\text{i.e., } R_e = 168 \Omega$$

Example 2

If the bus polarization R_p is 470 Ω (installed in the master) and 2 slaves have 4.7 Ω polarization, the equivalent polarization is:

$$1/R_e = 1/470 + 1/4700 + 1/4700$$

$$\text{i.e., } R_e = 1 / (1/470 + 1/4700 + 1/4700)$$

$$\text{and therefore } R_e = 390 \Omega$$

390 Ω is between 162 Ω and 650 Ω, and the schematic is correct.

For an ideal equivalent polarization (650 Ω), the master's polarization can be adapted so that:

$$1/650 = 1/R_m + 1/4700 + 1/4700$$

$$\text{i.e., } R_m = 1 / (1/650 - 1/4700 - 1/4700)$$

$$\text{and therefore } R_m = 587 \Omega$$

9. Appendix

9.7. RS485 schematic for the card

The RS485 interface on the Modbus card is electrically isolated from the drive.

Schematic diagram:

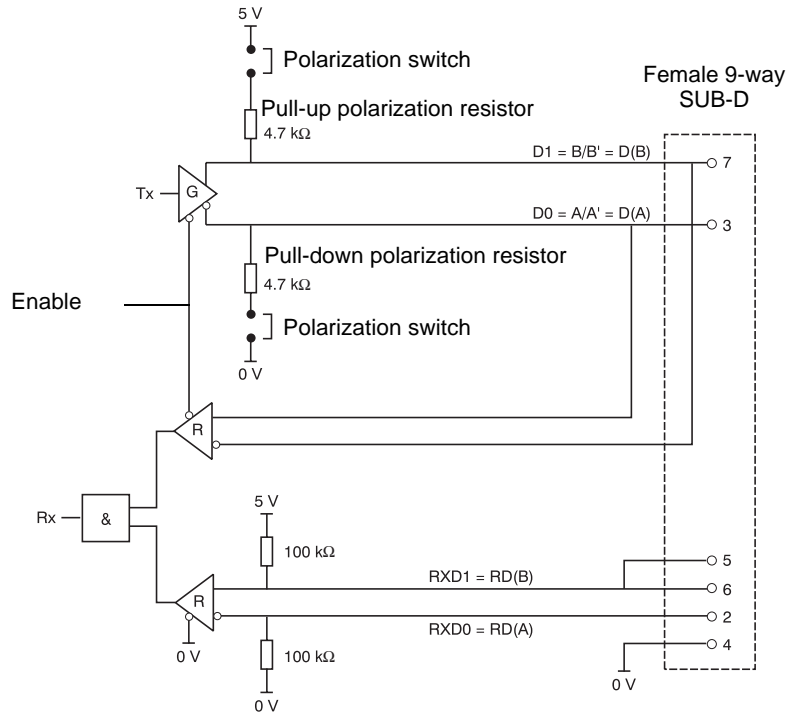

The polarization switches are used to connect or disconnect the pull-up and pull-down resistors, which implement either Modbus (no slave polarization) or Uni-Telway (4.7 kΩ polarization for each station) type polarization.

9.8. Card connector pinout

Contact no.	Signal
1	Reserved
2	RXD0 = RD(A)
3	D0 = A/A' = D(A)
4	Common = C/C' = 0VL
5	RxD1 = RD(B)
6	RxD1 = RD(B)
7	D1 = B/B' = D(B)
8	Not connected
9	Not connected

