

SpaceLogic KNX Weather station REG-K/4-gang

Operating instructions

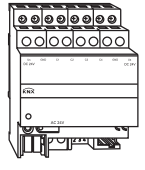

Art. no. MTN682991

Accessories

When the following measuring transducers are used, it is possible to access a pre-configuration in the software. If other sensors are used, the parameters to be configured must be determined beforehand.

- Weather combi-sensor DCF-77 (Art. no. MTN663692)
- Brightness sensor (Art. no. MTN663593)
- Twilight sensor (Art. no. MTN663594)
- Rain sensor (Art. no. MTN663595)
- Temperature sensor (Art. no. MTN663596)
- Wind sensor with 0-10 V interface (Art. no. MTN663591)
- Wind sensor with 0-10 V interface and heating (Art. no. MTN663592)
- Analogue input module REG/4-gang (Art. no. MTN682192)
- Power supply REG, AC 24 V/1 A (Art. no. MTN663529)

For your safety

⚠️ ⚠️ DANGER

HAZARD OF ELECTRIC SHOCK, EXPLOSION, OR ARC FLASH

Safe electrical installation must be carried out only by skilled professionals. Skilled professionals must prove profound knowledge in the following areas:

- Connecting to installation networks
- Connecting several electrical devices
- Laying electric cables
- Connecting and establishing KNX networks
- Safety standards, local wiring rules and regulations

Failure to follow these instructions will result in death or serious injury.

⚠️ CAUTION

The device may be damaged!

The terminal block for the connection of the combination sensor must be plugged on before the mains voltage is switched on and during operation to prevent the digital input from unintentional contact with live wires. This would endanger the safety of the entire system. As a result, the device and any sensors or analog input module connected may be irreparably damaged.

Failure to follow these instruction can result in equipment damage.

Getting to know the weather station

The KNX weather station detects and forwards climatic data and events. Up to four analogue measuring transducers and one digital combi-sensor can be connected. The device can evaluate both voltage signals and current signals:

Current signals	0–20 mA DC
	4–20 mA DC
Voltage signals	0–1 V DC
	0–10 V DC

The current inputs can be monitored for wire breakage. A maximum of four additional analogue sensors can be connected and evaluated with the REG/4-gang analogue input module.

The weather combi-sensor includes a wind sensor, precipitation sensor, twilight sensor and three brightness sensors (East, South, West). With integral DCF-77 receiver, antenna rotatable through 45° and integral heating.

⚠️ CAUTION

The device may be damaged!

The sensor's heating protects the electronics from moisture and condensation in the specified temperature range. It does not protect the housing or moving parts from ice.

Failure to follow these instruction can result in equipment damage.

⚠️ CAUTION

The awning / blind can become damaged

In low temperatures, the sensor can freeze and does not give measured values anymore. If this happens, connected awnings / blinds are not protected against strong wind.

Therefore, in addition to a wind threshold also use a temperature threshold (e.g. 0°C).

Failure to follow these instruction can result in equipment damage.

Connections, displays and operating elements

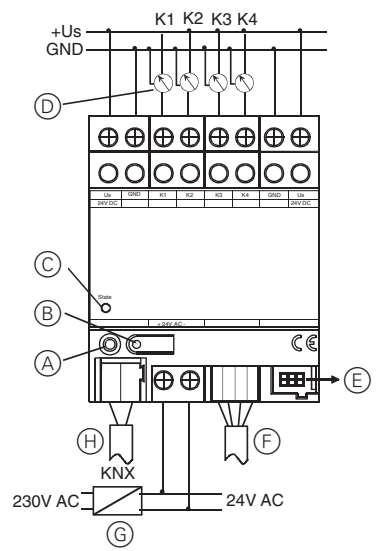

- +Us Power supply for external measuring transducer
- GND ref. potential for +Us and inputs K1...K4
- (A) Programming LED
- (B) Programming button
- (C) Status LED, three colours (red, orange, green)
- (D) Measured value inputs K1 ... K4
- (E) system connector, 6-pole, for module connection (system-Bus)
- (F) connecting terminal, 4-pole, for combination sensor (wind, rain, brightness, twilight)
- (G) External power supply
- (H) KNX-connecting terminal

Mounting the weather station

The device is installed on a DIN-rail TH 35 according to EN 60715, with the bus connection made via a bus connecting terminal.

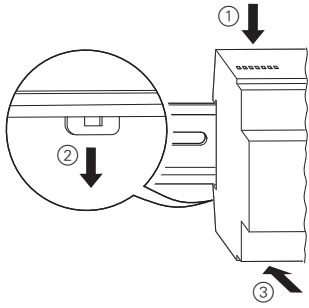

⚠ CAUTION

The device may be damaged!

Never connect the sensors at the inputs (K1...K4) of the weather station to the supply terminals U_S and GND of a connected analog input module. U_S and GND must not be interconnected with the corresponding terminals of another device.

The terminal block for the connection of the combination sensor must be plugged on before the mains voltage is switched on and during operation to prevent the digital input from unintentional contact with live wires. This would endanger the safety of the entire system. As a result, the device and any sensors or analog input module connected may be irreparably damaged.

Failure to follow these instructions can result in equipment damage.

To operate the device an external 24 V power supply is required.

This can also supply the connected sensors, heating for the sensors, or an analogue input module.

Power supply for connected sensors

⚠ CAUTION

Risk of irreparable damage to the device!

Never connect the sensors at the inputs (K1...K4) of the weather station to the supply terminals U_S and GND of a connected analog input module. U_S and GND must not be interconnected with the corresponding terminals of another device.

- Connected sensors can be supplied using the +US and GND terminals.
- The current consumption of all sensors that are supplied via these terminals may not exceed 100 mA.
- Two of each kind of terminal (+US and GND) are supplied, and are interconnected in pairs.
- Voltage is disconnected if there is a short circuit between the +US and GND.
- Power for connected sensors can also be supplied via external sources (for instance when their current consumption exceeds 100 mA). Terminals K1...K4 and GND are then used to connect to the sensor inputs.

Installing extensions

The following basic rules should be observed when installing a combi-sensor and extension module:

- One analogue input module can be connected.
- One extension module can be exchanged for another of the same type - e.g. if a module is faulty - during operation (disconnect module from voltage!). After a module has been replaced, the weather station carries out a reset after approx. 25 seconds. This re-initialises all inputs and outputs on the weather station and the connected modules and resets them to their original status.
- It is not permitted to add or remove modules without adapting the application and downloading it into the weather station, as this may lead to system malfunctions.

Status LED

Off:	no power supply
Orange / on:	module scan by weather station
Orange / flashing slowly:	Combi-sensor module scan (Waiting for allocation of a Combi-sensor)
Orange / flashing fast:	module scan REG extension module
Red / on:	Error: no project in controller
Red / flashing slowly:	Error: undervoltage at module connection
Red / flashing fast:	Error: parametrisation error
Green / flashing slowly:	address assignment, module scan completed, configuration OK
LED green/ flashing fast:	Parameter download into the modules
LED green / on:	Module scan completed, everything OK

Fashing slowly = 1/s
Fashing fast = 2/s

Technical data

Power supply	
Supply voltage:	24 V AC $\pm 10\%$
Power consumption:	Max. 250 mA
KNX	
Voltage:	24 V DC (+6 V / -4 V)
Power consumption:	typ. 150 mW
Ambient temperature:	-5 °C to +45 °C
Storage/transport temperature:	-25 °C to +70 °C
Humidity	
Environment/ storage/transport:	max. 93%, no moisture condensation
Type of protection:	IP 20 in accordance with EN 60529
Installation width:	4 depth units / 70 mm
Weight:	approx. 150 g
Connections	
Inputs, power supply:	Screw terminals single-wire 0.5–4 mm ² stranded wire (without ferrule) 0.34–4 mm ² stranded wire (with ferrule) 0.14–2.5 mm ² Connection and branch terminal
KNX:	
Weather combi-sensor	4-pole connecting terminal
Analog input module:	6-pole system connector
Sensor inputs	
Number:	4x analogue, 1x digital
Evaluable sensor signals (analog):	0–1 V DC, 0–10 V DC, 0–20 mA DC, 4–20 mA DC
Voltage measurement impedance:	approx. 18 k Ω
Current measurement impedance:	approx. 100 Ω
Supply for external sensors (+Us):	24 V DC. max. 100 mA DC
Connection of extension modules:	24 V DC. max. 80 mA DC
Subject to technical modifications.	

Schneider Electric -Contact

Schneider Electric Industries SAS
35 rue Joseph Monier
Rueil Malmaison 92500
France

If you have technical questions, please contact the Customer Care Centre in your country.

se.com/contact



UK Representative
Schneider Electric Limited
Stafford Park 5
Telford, TF3 3 BL, UK