

SpaceLogic KNX / Secure, Switch/Blind Master

Switch Blind Secure 5810/1.2

Application Description

MTN6705-0008S / MTN6805-0008

Release date 01/2026



Legal Information

The information provided in this document contains general descriptions, technical characteristics and/or recommendations related to products/solutions.

This document is not intended as a substitute for a detailed study or operational and site-specific development or schematic plan. It is not to be used for determining suitability or reliability of the products/solutions for specific user applications. It is the duty of any such user to perform or have any professional expert of its choice (integrator, specifier or the like) perform the appropriate and comprehensive risk analysis, evaluation and testing of the products/solutions with respect to the relevant specific application or use thereof.

The Schneider Electric brand and any trademarks of Schneider Electric SE and its subsidiaries referred to in this document are the property of Schneider Electric SE or its subsidiaries. All other brands may be trademarks of their respective owner.

This document and its content are protected under applicable copyright laws and provided for informative use only. No part of this document may be reproduced or transmitted in any form or by any means (electronic, mechanical, photocopying, recording, or otherwise), for any purpose, without the prior written permission of Schneider Electric.

Schneider Electric does not grant any right or license for commercial use of the document or its content, except for a non-exclusive and personal license to consult it on an "as is" basis.

Schneider Electric reserves the right to make changes or updates with respect to or in the content of this document or the format thereof, at any time without notice.

To the extent permitted by applicable law, no responsibility or liability is assumed by Schneider Electric and its subsidiaries for any errors or omissions in the informational content of this document, as well as any non-intended use or misuse of the content thereof.

Table of Contents

Safety Information.....	7
Before You Begin.....	8
Start-up and Test.....	9
Operation and Adjustments.....	10
About the Document.....	11
Operating ETS Software.....	16
Special Features of the ETS Software.....	16
Restoring Defaults.....	16
Dependent Functions and Parameters.....	16
Overview of Application Functions.....	17
General Settings.....	20
Device Protection and Cyber Security.....	20
Selection of the SpaceLogic KNX Extensions.....	20
Defining Channel Functions.....	21
Switch.....	22
Blind.....	22
Roller Shutter.....	22
Enabling Central Functions.....	23
Group Objects for Central Function.....	24
Enabling Central Function for Each Output.....	24
Central Function Delay Times.....	24
Extended Settings.....	25
Energy Saving.....	25
Device Safety.....	25
Group Objects for Central Safety.....	25
Safety Function Priority.....	25
Device Health.....	26
Cyclic Sending Live Signal.....	26
Failure Indicator.....	26
Switching Cycle Counter.....	26
Group Objects for Switch Counter.....	27
Global Settings for Scenes.....	27
Scene Names.....	27
Enable Scene Learning.....	27
Enable Description Text Field for Scenes.....	28
Global Settings for Feedback.....	28
Sending Delay after Bus Voltage Recovery.....	28
Manual Operation Settings.....	29
Activation of Manual Operation.....	29
Enable Button for Manual Operation via Object.....	29
Suspend Manual Operation Automatically.....	30
Send Status of Manual Operation via Object.....	30
Global Settings for Switching.....	30
Activation of the Collected Status Response.....	30
Priority of Functions for Switching.....	32
Global Settings for Roller Shutter and Blind.....	32
Weather Alarm Function.....	32

Priority of Functions for Roller Shutter and Blind	35
Calibration.....	35
PIN Code for Firmware Update	36
Device Information.....	36
Express Settings for Switching	37
Name of the Channel for Switching	37
Switching Mode	37
Switching	37
Blinking	39
Operating Hours Counter	43
Scenes	44
Enable Scenes	44
Number of Scenes	44
Time Delay for Scene Processing.....	45
Calling and Saving Scene Values	45
Overwrite Scene Values during Download.....	46
Priority	46
Group Object for Scene	47
Central Function for Switching	47
Status Response	47
Activating Extended Settings for Switching	47
Extended Settings for Switching	48
Time Settings	48
Staircase Lighting Time Function (Staircase Timer)	48
On-delay and Off-delay	53
Logic, Locking and Priority Settings.....	56
Logic Function	56
Functions with Higher Priority.....	60
Priority Function (Priority Control).....	60
Locking Function	61
Safety and Alarm Settings	63
Safety Function Switching	63
Alarm Function	64
Failure and Download Behavior	66
Express Settings for Blind/Roller Shutter	69
Blind/Roller Shutter Control	70
Group Objects for Express Settings – Blind/Roller Shutter.....	72
Channel Name	72
Drive Running Time	72
Same Running Times for Up and Down	73
Different Running Times for Up and Down	73
Pause Time before Reverting (Pause on Reverse)	74
Slat Control (for Blind only).....	74
Slat Rotation Time	74
Setting the Blind Type (for Blind only)	76
Slat Position after Movement	80
Locking Manual Mode	81
Group Objects for Lock of Manual Mode	81
Scenes	81
Enabling Scenes.....	82

Number of Scenes	82
Time Delay for Scene Processing.....	83
Calling and Saving Scene Values	83
Overwrite Scene Values during Download.....	84
Priority	84
Central Function for Blind	84
Enable Central Function for Each Drive	84
Status Response	85
Group Objects of Status Response for Blind/Roller shutter	85
Status of Height	86
Status of Slats (for Blind only)	86
Status of Moving	86
Automatic Status	86
Activating Extended Settings for Blind/Roller Shutter	86
Extended Settings for Blind/Roller Shutter.....	88
Extended Drive Timing.....	88
Idle Time until Upward Movement	88
Startup Delay	89
Deceleration Delay.....	89
Additional Start-up Time on Opening the Slat (for Blind only)	89
Automatic, Locking and Calibration Settings	90
Automatic Mode.....	90
Locking Function	92
Movement Range Limits.....	95
Calibration.....	98
Safety and Alarm Settings	102
Safety Function for Blind.....	102
Alarm Function	103
Weather Alarm Function	105
Failure and Download Behavior	109
Express Settings for Roller Shutter	111
Group Objects for Express Settings for Roller Shutter.....	111
Name of the Channel	111
Roller Shutter Control Drive Time.....	112
Locking Manual Mode	112
Group Objects for Lock of Manual Mode	112
Scenes	113
Group Objects for Scene	113
Central Function for Roller Shutter	113
Group Objects of the Central Function	114
Status Response	114
Group Objects of Status Response of Roller Shutter.....	114
Activating Extended Settings for Roller Shutter	114
Extended Settings for Roller Shutter.....	115
Extended Drive Timing.....	115
Automatic, Locking and Calibration Settings	115
Automatic Mode.....	115
Locking Function	117
Movement Range Limits.....	118
Calibration.....	119

Safety and Alarm Settings	119
Safety Function for Roller Shutter	119
Alarm Function	120
Weather Alarm Function.....	121
Group Objects for Weather Alarms	122
Failure and Download Behavior	122

Safety Information

Important Information

Read these instructions carefully, and look at the equipment to become familiar with the device before trying to install, operate, service, or maintain it. The following special messages may appear throughout this documentation or on the equipment to warn of potential hazards or to call attention to information that clarifies or simplifies a procedure.



The addition of this symbol to a "Danger" or "Warning" safety label indicates that an electrical hazard exists which will result in personal injury if the instructions are not followed.



This is the safety alert symbol. It is used to alert you to potential personal injury hazards. Obey all safety messages that follow this symbol to avoid possible injury or death.

DANGER

DANGER indicates a hazardous situation which, if not avoided, **will result in** death or serious injury.

WARNING

WARNING indicates a hazardous situation which, if not avoided, **could result in** death or serious injury.

CAUTION

CAUTION indicates a hazardous situation which, if not avoided, **could result in** minor or moderate injury.

NOTICE

NOTICE is used to address practices not related to physical injury.



The addition of this symbol to a “Danger” or “Warning” safety label indicates that an electrical hazard exists which will result in personal injury if the instructions are not followed.



This is the safety alert symbol. It is used to alert you to potential personal injury hazards. Obey all safety messages that follow this symbol to avoid possible injury or death.

DANGER

DANGER indicates a hazardous situation which, if not avoided, **will result in** death or serious injury.

WARNING

WARNING indicates a hazardous situation which, if not avoided, **could result in** death or serious injury.

CAUTION

CAUTION indicates a hazardous situation which, if not avoided, **could result in** minor or moderate injury.

NOTICE

NOTICE is used to address practices not related to physical injury.

Please Note

Electrical equipment should be installed, operated, serviced, and maintained only by qualified personnel. No responsibility is assumed by Schneider Electric for any consequences arising out of the use of this material.

A qualified person is one who has skills and knowledge related to the construction and operation of electrical equipment and its installation, and has received safety training to recognize and avoid the hazards involved.

Before You Begin

Do not use this product on machinery lacking effective point-of-operation guarding. Lack of effective point-of-operation guarding on a machine can result in serious injury to the operator of that machine.

WARNING

UNGUARDED EQUIPMENT

- Do not use this software and related automation equipment on equipment which does not have point-of-operation protection.
- Do not reach into machinery during operation.

Failure to follow these instructions can result in death, serious injury, or equipment damage.

This automation equipment and related software is used to control a variety of industrial processes. The type or model of automation equipment suitable for each application will vary depending on factors such as the control function required, degree of protection required, production methods, unusual conditions,

government regulations, etc. In some applications, more than one processor may be required, as when backup redundancy is needed.

Only you, the user, machine builder or system integrator can be aware of all the conditions and factors present during setup, operation, and maintenance of the machine and, therefore, can determine the automation equipment and the related safeties and interlocks which can be properly used. When selecting automation and control equipment and related software for a particular application, you should refer to the applicable local and national standards and regulations. The National Safety Council's Accident Prevention Manual (nationally recognized in the United States of America) also provides much useful information.

In some applications, such as packaging machinery, additional operator protection such as point-of-operation guarding must be provided. This is necessary if the operator's hands and other parts of the body are free to enter the pinch points or other hazardous areas and serious injury can occur. Software products alone cannot protect an operator from injury. For this reason the software cannot be substituted for or take the place of point-of-operation protection.

Ensure that appropriate safeties and mechanical/electrical interlocks related to point-of-operation protection have been installed and are operational before placing the equipment into service. All interlocks and safeties related to point-of-operation protection must be coordinated with the related automation equipment and software programming.

NOTE: Coordination of safeties and mechanical/electrical interlocks for point-of-operation protection is outside the scope of the Function Block Library, System User Guide, or other implementation referenced in this documentation.

Start-up and Test

Before using electrical control and automation equipment for regular operation after installation, the system should be given a start-up test by qualified personnel to verify correct operation of the equipment. It is important that arrangements for such a check are made and that enough time is allowed to perform complete and satisfactory testing.

▲ WARNING

EQUIPMENT OPERATION HAZARD

- Verify that all installation and set up procedures have been completed.
- Before operational tests are performed, remove all blocks or other temporary holding means used for shipment from all component devices.
- Remove tools, meters, and debris from equipment.

Failure to follow these instructions can result in death, serious injury, or equipment damage.

Follow all start-up tests recommended in the equipment documentation. Store all equipment documentation for future references.

Software testing must be done in both simulated and real environments.

Verify that the completed system is free from all short circuits and temporary grounds that are not installed according to local regulations (according to the National Electrical Code in the U.S.A, for instance). If high-potential voltage testing is necessary, follow recommendations in equipment documentation to prevent accidental equipment damage.

Before energizing equipment:

- Remove tools, meters, and debris from equipment.
- Close the equipment enclosure door.
- Remove all temporary grounds from incoming power lines.

- Perform all start-up tests recommended by the manufacturer.

Operation and Adjustments

The following precautions are from the NEMA Standards Publication ICS 7.1-1995:

(In case of divergence or contradiction between any translation and the English original, the original text in the English language will prevail.)

- Regardless of the care exercised in the design and manufacture of equipment or in the selection and ratings of components, there are hazards that can be encountered if such equipment is improperly operated.
- It is sometimes possible to misadjust the equipment and thus produce unsatisfactory or unsafe operation. Always use the manufacturer's instructions as a guide for functional adjustments. Personnel who have access to these adjustments should be familiar with the equipment manufacturer's instructions and the machinery used with the electrical equipment.
- Only those operational adjustments required by the operator should be accessible to the operator. Access to other controls should be restricted to prevent unauthorized changes in operating characteristics.

About the Document

Document Scope

This document describes the Switch Blind Secure software application 5810/1.1. The software application is designed to program the SpaceLogic KNX, Secure, Switch/Blind Master.

You can add up to two Switch/Blind extensions to the device. Together with the two extensions, up to 24 switching outputs are available. Two switching outputs can be configured as blind/roller shutter outputs.

The basic settings of the device are set on the **General settings** tab. Here you define the device configuration from master and extensions. You can then also specify the functions of the outputs here.

General Settings, page 20

The functions of the outputs are parameterized on the **Express settings** and **Extended settings** tabs of the outputs for switching, roller shutter and blind.

Express Settings for Switching, page 37

Express Settings for Blind/Roller Shutter, page 69

Extended Settings for Switching, page 48

Extended Settings for Blind/Roller Shutter, page 88

You can use the **Extended settings** of the device to configure the global settings of the devices as needed. (Extended Settings, page 25).

Validity Note

The information contained in this guide is accurate and applicable as of the publication date. Any updates or changes to the software application will be documented in subsequent revisions of this guide. Users are advised to refer to the latest version of the user guide for the most current information.

The device is commissioned using KNX-certified software. The application and the technical descriptions are updated regularly and can be found on the Internet. This application runs in conjunction with ETS software version 5 or higher.

General Cybersecurity Information

In recent years, the growing number of networked machines and production plants has seen a corresponding increase in the potential for cyber threats, such as unauthorized access, data breaches, and operational disruptions. You must, therefore, consider all possible cybersecurity measures to help protect assets and systems against such threats.

To help keep your Schneider Electric products secure and protected, it is in your best interest to implement the cybersecurity best practices as described in the [Cybersecurity Best Practices](#) document.

Schneider Electric provides additional information and assistance:

- [Subscribe to the Schneider Electric security newsletter.](#)
- [Visit the Cybersecurity Support Portal web page to:](#)
 - [Find Security Notifications.](#)
 - [Report vulnerabilities and incidents.](#)
- [Visit the Schneider Electric Cybersecurity and Data Protection Posture web page to:](#)
 - [Access the cybersecurity posture.](#)
 - [Learn more about cybersecurity in the cybersecurity academy.](#)
 - [Explore the cybersecurity services from Schneider Electric.](#)

Product Related Cybersecurity Information

KNX Data Secure

The KNX standard has been extended by KNX Data Secure to protect KNX installations from unauthorized access. KNX Data Secure reliably prevents the monitoring of communication and manipulation of the installation. KNX Data Secure describes the encryption at telegram level so that communication via objects is encrypted and therefore secure.

Encrypted telegrams are longer than the previously used unencrypted telegrams. For secure programming via the KNX bus, it is therefore necessary for the interface (e.g. USB) and any line couplers to support these „KNX long frames“.

Special conditions must be observed when using secure devices in the ETS. Please refer to the relevant web pages on the KNX website <https://www.knx.org>

Protecting your data is a top priority. Use the options in the ETS and KNX Data Secure to protect your data, configuration and installations from unauthorized access.

Protecting the Project Configuration via the ETS

In the ETS, you can define a project password that protects the devices and configuration data from unauthorized access.

1. Find your project in the **Overview** tab of the ETS.
2. Click the **Details > Security > Add device certificate** and set your project password.

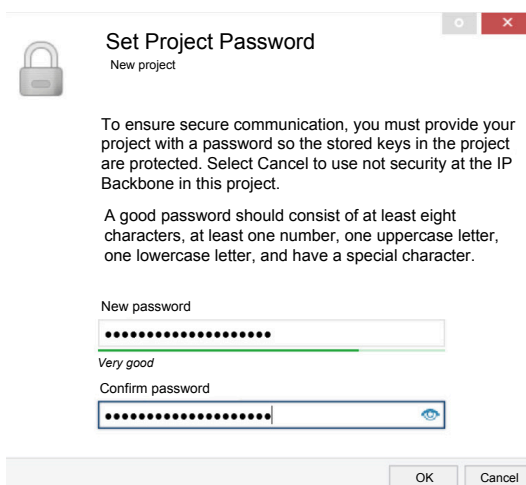

NOTE: A good password should consist of at least 8 characters in the project window, consisting of a number, an upper case letter, a lower case letter and a special character. Never use weak PIN codes, e.g., 1234, 0000.

3. Scan or enter the device certificates for all devices in your project that you intend to download using secure commissioning > click **OK**



NOTE: The certificate consists of the serial number and the security key FDSK (Factory Default Setup Key). The FDSK is only used for initial commissioning and is replaced by the ETS during the first download. This prevents unauthorized persons from gaining access to the installation despite knowing the FDSK. The FDSK is printed on the device label both as a QR code and in text form.

Background information on the encryption process

- Read or enter the FDSK into the ETS.
- The ETS then generates a device-specific tool key.
- When configuring the device, the ETS sends the tool key to the device. The transmission is encrypted and authenticated with the FDSK.
- From this point on, the device only accepts the tool key for communication and the FDSK can only be used to reset the device to the delivery status. All safety-relevant data is deleted during this reset. Therefore, **please keep the FDSK in your project documents.**
- The ETS then generates runtime keys, which are required for protected group communication. The transmission is encrypted and authenticated with the tool key.

Available Languages of the Document

The document is available in these languages:

- English
- French
- German
- Spanish

Related Documents

Title of documentation	Reference number
SpaceLogic KNX, Secure, Switch/Blind Master, Installation and Connection	MTN6705-0008S_HW

To find documents online, visit the Schneider Electric download center (www.se.com/ww/en/download/).

Information on Non-Inclusive or Insensitive Terminology

As a responsible, inclusive company, Schneider Electric is constantly updating its communications and products that contain non-inclusive or insensitive terminology. However, despite these efforts, our content may still contain terms that are deemed inappropriate by some customers.

Trademarks

QR Code is a registered trademark of DENSO WAVE INCORPORATED in Japan and other countries.

Operating ETS Software

Essential Skills for ETS Operation in KNX Systems

To operate the ETS software application, you need the following skills:

1. Basic Windows operation: Understanding the basic rules for operating programs using Windows is essential.
2. ETS software knowledge: Familiarity with the ETS software, including how to navigate its interface and use its features.
3. KNX system understanding: Knowledge of the KNX system, including how to select the correct sensors and actuators, transfer them to the line, and commission them.
4. Programming skills: Ability to program the KNX push button, which involves setting parameters, assigning group addresses, and configuring functions

ETS Parameter Settings and User Interface Overview

Tables with  describe parameter settings in ETS.

In the ETS, the device parameters are opened using the **Parameters** tab.

The user interface is divided into 2 sections: The tabs are on the left and the parameters on the right, together with their values.

The main setting items are on the left.	The specific parameters and their value settings are on the right.	
 Extended settings	Global settings for scene Naming of the scenes: (The values on the bus are always 0 – 63)	Scene address 0 – 63 Scene address 1 – 64

Special Features of the ETS Software

Restoring Defaults

You can set the factory-specified defaults using the **Default parameters** service button in the ETS.

You can use the **Default** and **Default parameters** service buttons to switch all parameters back to the settings on delivery (following consultation). The ETS will then permanently delete all manual settings.

Dependent Functions and Parameters

Many functions are affected by how other functions are set. This means that dependent functions can only be seen and selected in the ETS when the upstream function is enabled.

- If you de-select functions or change parameters, previously connected group addresses may be removed in the process.
- The values of some parameters only become active once the functions influenced by these parameters are activated.

Overview of Application Functions

General settings, page 20

Central functions	Disabled Enabled Enabled/Delayed
Select SpaceLogic KNX Extensions 1 and 2	MTN6805-0008 Switch/Blind
Select channel functions of the master/extensions for each output	Disabled Switch Roller shutter Blind

Extended Settings, page 25

Energy saving	LEDs on the device can be set to standby after (0...255, unit = 1 min, 0 = always on)
Device safety	Disabled At object value "1" At object value "0"
Device health	Cyclic sending live signal Enable outputs for failure indication
Switching cycle counter	Master/Extension 1/2 switching cycle counter (Disabled/Enabled)
Global settings for scene	Naming of the scenes Enable learning of scenes Enable description text field for scenes
Delay for central functions (Only if central function is enabled with delay)	Delay of central functions all channels Time between central functions per channel
Global settings for feedback	Delay of status response for all channels Time between status response per channel
Sending delay	Sending delay after bus voltage recovery
Manual operation settings	Activation of manual operation on the device is not allowed/ allowed Enable button for manual operation via object Suspend manual operation automatically Send status of manual operation via object
Global settings for switching	Collected status response Priority of functions
Global settings for roller shutter and blind	Weather alarm functions Priority of functions Calibration
PIN Code for Firmware Update via USB	Enter a PIN code for firmware update.
Device information	Firmware Master Firmware Extension 1/2 Uptime Master (days/hours/min/sec)

Express Settings for Switching, page 37

Name of the channel	
Switching mode	Switching/Blinking
Contact mode	Normally opened/closed
Operating hours counter	Disabled/Enabled
Scenes	Disabled/Enabled
Central function	Disabled/Enabled
Status response	Normal behavior/Inverted
Extended settings for switching	

Extended Settings for Switching, page 48

Scene settings (if Scenes function in Express settings is enabled)	Required number of scenes
	Overwrite scene values in actuator during download
	Time delay for scene processing
	Scene Nr. <ul style="list-style-type: none"> • Disabled/Enabled • Scene description • Scene address • Scene switching state
Time settings	Staircase lighting time
	On-delay time
	Off-delay time
Logic, Locking & Priority settings	Priority function
	Logic function
Safety and alarm settings	Safety function (if Device safety in Extended settings is enabled)
	Alarm function
	Failure and download behavior

Express Settings for Blind/Roller Shutter, page 69

Name of the channel	
Blind/Roller shutter control	Use same time for up and down
	Up/Down time (same or different)
	Pause time before reverting
Slat control	Slat rotation time
	Steps that shall be executed during slat rotation
	Movement of the existing blind
	Slat position after movement in %
Lock of manual mode	Disabled/Enabled
Scenes	Disabled/Enabled
Central function	Disabled/Enabled
Status of height	Disabled/Enabled
Status of slat	Disabled/Enabled

Express Settings for Blind/Roller Shutter, page 69

Status of moving Disabled/Enabled

Extended settings for blind/
roller shutter

Extended Settings for Blind/Roller Shutter, page 88

Scene settings (if Scenes function in Express settings is enabled)	<p>Required number of scenes</p> <p>Overwrite scene values in actuator during download</p> <p>Time delay for scene processing</p> <p>Scene Nr.</p> <ul style="list-style-type: none"> • Disabled/Enabled • Scene Nr. description • Scene Nr. address • Scene Nr. switching state
Extended drive timing	<p>Idle time until upward movement</p> <p>Startup delay</p> <p>Deceleration delay</p> <p>Additional startup time when opening slat upwards/downwards</p>
Automatic, Locking & Calibration settings	<p>Automatic mode</p> <p>Locking function</p> <p>Movement range limits</p> <p>Calibration</p>
Safety and alarm settings	<p>Safety function (if Device safety in Extended settings is enabled)</p> <p>Alarm function</p> <p>Weather alarm (if Weather alarm is enabled in Extended settings)</p> <p>Failure and download behavior</p>

General Settings

You can define the basic configuration of the device on the **General settings** tab.

Device Protection and Cyber Security

The SpaceLogic KNX Switch/Blind Master has a micro USB B interface. This is intended for diagnostic and updating the firmware of the device. A 4-digit PIN code should be set in the ETS application to prevent unauthorized persons from manipulating the firmware (Cyber Security).

This is requested before a firmware update with the Schneider Electric “Device Firmware Update Tool”. Without this PIN, an update is not possible. You have 3 attempts to enter a valid access code. If the code is not entered correctly, the service port is disabled for 1 hour or the device needs to be restarted (power reset or device reset).



✕	General settings	Device protection information:
		No valid PIN Code for Firmware Update! Please enter a valid PIN code in the extended settings before downloading your configuration!

The PIN code is entered on the **Extended settings** tab (PIN Code for Firmware Update, page 36). Weak PINs are forbidden (e.g., 1234, 1111, 2222, ...).

Selection of the SpaceLogic KNX Extensions

The SpaceLogic KNX Switch/Blind Master is a KNX actuator that switches a maximum of 8 outputs (such as lamps) or controls a maximum of 4 blind motors with end switches. The distribution of functions between channels is freely selectable and depends on your requirements.

If you need more channels for your project, you can connect so-called SpaceLogic KNX Switch/Blind extensions to the master. As with the master, channels can be split into switching channels or blind channels. Since a master can control a maximum of 2 extensions, it is possible to switch a maximum of 24 outputs or control a maximum of 12 blind motors.

✕	General settings	Selection of the SpaceLogic KNX extension	
		Type of Extension 1	Disabled
			MTN6805-0008 Switch/Blind
		Type of Extension 2	Disabled
		MTN6805-0008 Switch/Blind	

Selecting **MTN6805-0008 Switch/Blind** adds Extension 1. The 8 new outputs with tabs, parameters, channels and channel functions are now available in the application.

Extension 1 is displayed as an image to the right of the master.

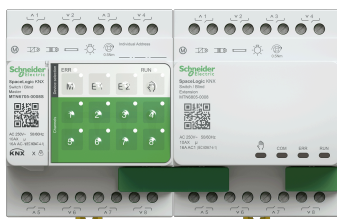

Selecting **MTN6805-0008 Switch/Blind** as Extension 2 adds the second Switch/Blind extension.

Extension 2 is displayed as an image to the right of Extension 1.



For Extension 2, the new outputs are now displayed with tabs, parameters, channels and channel functions.

Defining Channel Functions

Each output can be operated in the function disabled or switch or blind or roller shutter. In blind and roller shutter operation, two outputs are grouped together to form a single channel. The output contacts of the relays are then electronically interlocked. This means that you cannot switch on both contacts of a motor channel simultaneously. This applies to control via bus telegrams and to manual operation on the device.

NOTICE

CHECK BEFORE COMMISSIONING:

The load connections and the order of the devices (Master > Extension 1 > Extension 2) must correspond to your ETS programming.

- Connect blind motors to the blind channels specified in the ETS.
- Connect loads to the switching channels specified in the ETS.
- If the extension is planned as extension 1 (E1), connect it directly to the master.
- If the extension is planned as extension 2 (E2), then connect it to extension 1.

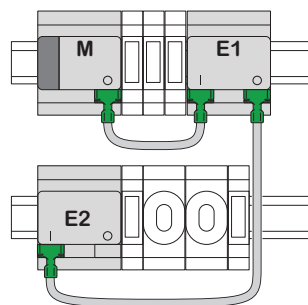

An extension cannot be put into operation if the order of the devices does not correspond to your programming in the ETS.

✂	General settings	Channel function for master	
	Output 1-8	Disable	Switch
		Roller shutter	Blind

After activation of Extension 1



	General settings	Channel function for Extension 1
		Output 1-8
		Disable
		Switch
		Roller shutter
		Blind

After activation of Extension 2

	General settings	Channel function for Extension 2
		Output 1-8
		Disable
		Switch
		Roller shutter
		Blind

Switch



To switch electrical loads, you can switch the channel function of the device to **Switch** mode.

	General settings	Channel function Master / Extension 1 / Extension 2 Output 1-8	Switch
		Express settings for switching	...
	Master/Ext. 1/2 Output 1-8 -Switch: Switching		

Express Settings for Switching, page 37

Blind

To control blinds, you can switch the channel function of the device to **Blind** mode.

	General settings	Channel function Master / Extension 1 / Extension 2 Output 1-8	Blind
		Express settings for blind	...
	Master/Ext. 1/2 Output 1-8 -Blind: Blind		

Express Settings for Blind/Roller Shutter, page 69

Roller Shutter

To control roller shutter, you can switch the channel function of the device to **Roller shutter** mode.

	General settings	Channel function Master / Extension 1 / Extension 2 Output 1-8	Roller shutter
---	------------------	---	-----------------------



Master/Ext. 1/2
Output 1-8 – Roller
shutter: Roller
shutter

Express settings for Roller shutter ...

Express Settings for Roller Shutter, page 111

Enabling Central Functions

The central function allows you to switch multiple output switching channels simultaneously with a telegram via the **Central - Switch object**.

This functionality is available, for example, if you want to switch off all lamps at the press of a button when leaving the house and switch on all lamps at the press of a button when cleaning the house or in the event of an alarm.

Decentralized control without central function:

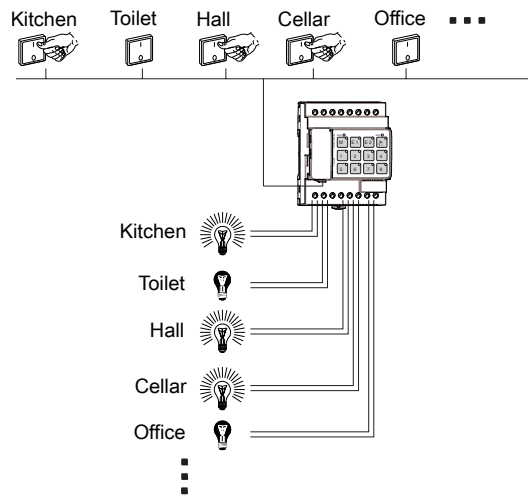

Centralized control with central function:

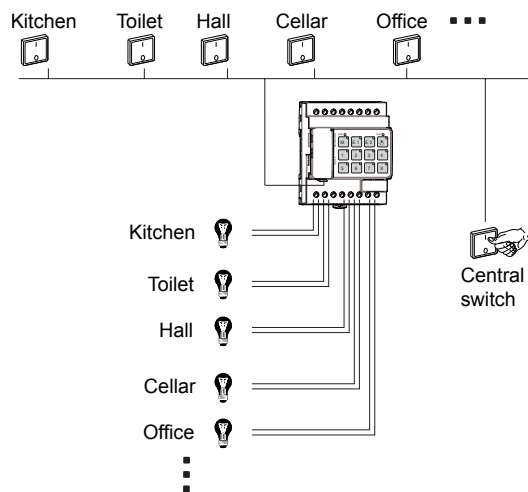

For blinds and roller shutters, there is a separate central object with a corresponding central object.

In order to use the central function for the individual switch/blind/roller shutter channels, you must first enable the global function on the **General settings** tab.

	General settings	Central functions	Disabled
			Enabled
			Enabled/Delayed

Following enabling, the group objects appear and all outputs are enabled for the central function.

Group Objects for Central Function

No.	Name	Object function	Length	Behavior	Data Type
1	Central	Switch	1 bit	Received	1.001 Switch
2	Central	Move up/down roller shutter	1 bit	Received	1.008 Up/Down
3	Central	Move up/down blind	1 bit	Received	1.008 Up/Down

Enabling Central Function for Each Output

The central function for each output/drive is enabled or disabled on the **Express settings** for **Switching/Roller shutter/Blind** tabs.

Central Function for Switching, page 47

Central Function for Blind, page 84

Central Function for Roller Shutter, page 113

Central Function Delay Times

The delay times for all channels together are parameterized on the **Extended settings** tab.

	Extended settings	Delay of central functions all channels (0...255, unit = 100ms)	0
		Time between central functions per channel (2...255, unit = 100 ms)	5

The central function has the same priority as the normal switching function. Receiving a new object value via the **central object** has the same effect as receiving a new object value for the switch object of the output.

Extended Settings

In the **Extended settings**, you can configure global device functions for the master and the extensions.

Energy Saving

The status LEDs of the channels on the master can be switched off automatically after a period of between 1 minute and 255 minutes. In this way, you do not illuminate the switch cabinet unnecessarily. Pressing a button reactivates the LEDs for the preset time.

✕	Extended settings	Energy saving	
		LEDs on the device can be set to standby after (0...255, unit = 1 min, 0 = always on)	0

Device Safety

This parameter activates the central safety object.

For each channel, a channel parameter can be used to determine whether and how this channel should respond to the safety object. The object value for the device safety function can also be set.

The device then waits for a telegram from an external sender within the set cycle time. If such a telegram is not received within the monitoring time, it is then possible to decide for each channel what should happen.

Switch: Safety Function Switching, page 63

Blind: Safety Function for Blind, page 102

Roller shutter: Safety Function for Roller Shutter, page 119

✕	Extended settings	Device safety	
		Device safety	At object value "1" At object value "0" Disabled
		Cycle time surveillance for Safety object (0 ... 255, unit = 1 s, 0 = inactive)	0

After enabling device safety function, the **Safety** group object appears.

Group Objects for Central Safety

No.	Name	Object function	Length	Behavior	Data Type
23	Central	Safety	1 bit	Received	1.005 Alarm

Safety Function Priority

The safety function has the highest priority.

Device Health

Cyclic Sending Live Signal

With the setting **Cyclic sending live signal** > 0, the central sign of life object is activated (**live signal**).

If activated, the device cyclically sends the value “1” with the cycle time set. This information is only a sign of life from the KNX master. Here, for example, the device can be monitored in a visualization.

	Extended settings	Device health
		Cyclic sending live signal (0...255, unit = 1 s, 0 = inactive) 0

Group Objects for Live Signal

No.	Name	Object function	Length	Behavior	Data Type
26	Central	Live signal	1 bit	Sending	1.017 Trigger

Failure Indicator

The failure indicator of the device can be activated in the ETS. Failure indication is carried out using two group objects.

	Extended settings	Device health
		Enable outputs for failure indication Disabled Enabled

Group Objects for Failure Indicator

No.	Name	Object function	Length	Behavior	Data Type
27	Master	Fault - Internal	1 bit	Sending	1.001 Switch
28	Master	Fault - External	1 bit	Sending	1.001 Switch

The **Fault – Internal** object signals internal device faults detected during the self-test. The Schneider-Electric **Device Firmware Update Tool** can be used to diagnose the fault with the integrated diagnostics function.

The **Fault – External** object signals external installation faults. The Schneider-Electric **Device Firmware Update Tool** can be used to diagnose the fault with the integrated diagnostics function.

Switching Cycle Counter

If you enable **Switching cycle counter**, all switching actions of a relay are counted and stored persistently in the memory. The actual value can be read for each relay via a 2-byte **Switching cycle counter** group object.

By default, only C-Flag and R-Flag are set to avoid high bus traffic. The firmware checks the internal counters cyclically every 10 seconds. If the value changes, it is sent via the group object.

You can read the actual values via group objects. If you want to get to know the values without reading, you have to set the T-Flag for the object.

You have to enable the visibility of group objects in “**Extended settings**” for the device. You can enable the visibility separately for each device (Master and Extensions).

	Extended settings	Switching cycle counter	
		Master switching cycle counter	Disabled/Enabled
		Extension 1 switching cycle counter	Disabled/Enabled
		Extension 2 switching cycle counter	Disabled/Enabled

Group Objects for Switch Counter

If you enable the **Switch counter**, group objects for each relay appear in the special object folder **Switching cycle counter**.

No.	Name	Object function	Length	Behavior	Data Type
31 – 38	Master Output #	Switching cycle counter	2 bytes	Sends/Reads	2 byte unsigned value
39 – 46	Extension 1 Output #	Switching cycle counter	2 bytes	Sends/Reads	2 byte unsigned value
47 – 54	Extension 2 Output #	Switching cycle counter	2 bytes	Sends/Reads	2 byte unsigned value

By default only C-Flag and R-Flag are set to avoid high bus traffic.

The firmware checks the internal counters cyclically every 10 seconds. If the value changes, it is sent via the group object.

You can read the actual values via group objects. If you want to get to know the values without reading, you have to set the T-Flag for the object.

Global Settings for Scenes

Scene Names

This parameter is used to define the scene numbering view for the user in the ETS. Either **Scene address 1 – 64** or **Scene address 0 – 63**. The values on the bus are always 0 – 63.

	Extended settings	Global settings for scene	
		Naming of the scenes (The values on the bus are always 0-63)	Scene address 0 – 63
			Scene address 1 – 63

Enable Scene Learning

The parameter **Enable learning of scenes** is activated as standard and the learning of scenes is thus allowed. This can be disabled globally.

Extended settings	Global settings for scene	
	Enable learning of scenes	Yes No

Enable Description Text Field for Scenes

A description text can be stored for each scene. This provides clarity for the different scenes. This function can be switched off globally here.

Extended settings	Global settings for scene	
	Enable description text field for scenes	Yes No

Global Settings for Feedback

Here you can set the delay of the feedback of this device and the time interval between multiple feedback telegrams.

If there is only one telegram to be sent, it is sent as set in the parameter **Delay of status response for all channels**. If more than one response is active, the other responses will be sent at the delay time intervals set by the parameter **Time between responses per channel**.

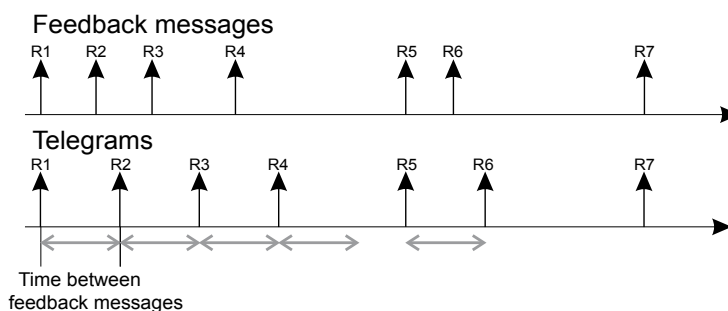

Extended settings	Global settings for feedback	
	Delay of status response for all channels (0...255, unit = 100 ms)	0
	Time between status response per channel. (0...50, unit = 100 ms)	0

Sending Delay after Bus Voltage Recovery

It is possible to set a global sending delay for all telegrams after bus voltage recovery.

Once the bus voltage has been recovered, all send activities of the device are delayed.

Extended settings	Sending delay
-------------------	----------------------

	Sending delay after bus voltage recovery	0
(0...255, unit = 1 s)		

Manual Operation Settings

On the front side of the master, there is a channel button for each channel and a corresponding yellow LED for indicating the channel status (channel status LED).

In addition to the channel buttons, the device also has device selection buttons (**M** for the master; **E1** for Extension 1; **E2** for Extension 2). With these buttons, you first select the device (Master/Extension 1/Extension 2) whose status you want to display or which you want to operate. Manual operation is performed after pressing the **Manual push-button** and then a channel button.

Activation of Manual Operation

Manual operation can be disabled on the device in the ETS. This means that operation on the device is no longer possible.



	Extended settings	Manual operation settings
	Activation of manual operation on the device is	Not allowed Allowed

Manual operation is allowed as a standard.

Enable Button for Manual Operation via Object

Switching to manual operation control via the **Manual push-button** is only possible if the object **Enable button for manual operation via object** has the value "1". If the object has the value "0", toggling to manual operation is disabled. If toggling is disabled by a telegram, the device also automatically deactivates manual operation.

The value of the object **Enable button for manual operation via object** can be parameterized after bus voltage recovery. The value "1" enables the **Manual push-button** and the outputs can be operated on the device. The value "0" disables the **Manual push-button** after bus voltage recovery.

	Extended settings	Manual operation settings
	Enable button for manual operation via object	No Yes
	Object value after bus voltage recovery	0 (Manual push-button disabled) 1 (Manual push-button enabled) As before bus voltage failure

Group Objects for Manual Operation

No.	Name	Object function	Length	Behavior	Data Type
15	Master keypad	Enable button for manual operation	1 bit	Received	1.003 Enable

Suspend Manual Operation Automatically

You can set a time limit for manual operation when toggling to it. To do so, set the parameter **Suspend manual operation automatically** to **Yes**

Then set the parameter **Suspend manual operation after 1...48 in hours** to the desired time after which the device automatically resets manual operation. You can read the current operating status from the manual operation LED and you will receive feedback via the **Status of manual operation** object if you have enabled this function.

Extended settings	Manual operation settings	
	Suspend manual operation automatically	No Yes
	Suspend manual operation after (1...48, unit = 1 hour)	2

Send Status of Manual Operation via Object

In addition to the possibility of enabling manual operation via the **Enable manual operation** object, it is also possible to send the status of the manual operation via the **Status of manual operation** object. You can read the current operating status from the manual operation LED and you will receive feedback via the **Status of manual operation** object if you have enabled this function.

Extended settings	Manual operation settings	
	Send status of manual operation via object	No Yes

Once **Send status of manual operation via object** has been enabled, the group object appears.

Group Object for Manual Operation Status

No.	Name	Object function	Length	Behavior	Data Type
16	Master keypad	Status of manual operation	1 bit	Send/Read	1.001 Switch

Global Settings for Switching

The global settings for the switching functions are defined here.

Activation of the Collected Status Response

The **collected status response** can be activated on the device in the ETS.

Extended settings	Global settings for switching	
	Collected status response	Disable Enable
	Assign channel status to 1bit value	Normal behavior (Pressed = 1, Released = 0)

	Inverted
Delay time sending (0...255, unit = 1 s)	60

With the **collected status response** object, you can send the status responses coded bit-by-bit via a 4-byte telegram with a time delay.

Each device (Master / Extension 1 / Extension 2) has its own **collected status response** object.

The **collected status response** is intended to save group addresses and to reduce the bus load, e.g., in the case of a **Central Off** telegram, the 8 channels are grouped together to form a single **collected status response**.

The 4-byte object has the following structure. The upper two bytes indicate which status bit is valid ("1" = valid, "0" = invalid). The lower two bytes indicate the statuses (pressed or released) of the channels.

Byte 4	0	Not used
	1	Not used
	2	Not used
	3	Not used
	4	Not used
	5	Not used
	6	Not used
	7	Not used
Byte 3	0	Valid output 1
	1	Valid output 2
	2	Valid output 3
	3	Valid output 4
	4	Valid output 5
	5	Valid output 6
	6	Valid output 7
	7	Valid output 8
Byte 2	0	Not used
	1	Not used
	2	Not used
	3	Not used
	4	Not used
	5	Not used
	6	Not used
	7	Not used
Byte 1	0	Status output 1
	1	Status output 2
	2	Status output 3
	3	Status output 4
	4	Status output 5
	5	Status output 6
	6	Status output 7
	7	Status output 8
Byte 4	0	Not used

	1	Not used
	2	Not used
	3	Not used
	4	Not used
	5	Not used
	6	Not used
	7	Not used

Example:

Master with 8 switching channels, channels 2 and 6 are pressed:

00000000 11111111 00000000 00100010.

You can define or invert the value of the **collected status response** (pressed = 1, released = 0 or pressed = 0, released = 1) via the parameter **Assign channel status to 1-bit value**.

Once the set sending delay has expired, the current status of the output channels is sent to the bus.

Group Objects for Collected Status

No.	Name	Object function	Length	Behavior	Data Type
10	Master	Collected status	4 bytes	Send/Read	27.001 bit-combined info On/Off
11	Extension 1	Collected status	4 bytes	Send/Read	27.001 bit-combined info On/Off
12	Extension 2	Collected status	4 bytes	Send/Read	27.001 bit-combined info On/Off

Priority of Functions for Switching

The global priorities for switching are defined here.

The safety function has the highest priority.

The other priorities can be selected here.

 Extended settings	Global settings for switching
	Priority of functions <div style="float: right; margin-top: 5px;"> Safety > Alarm > Lock/Prio > all other Safety > Lock/Prio > Alarm > all other </div>

Global Settings for Roller Shutter and Blind



The global settings for roller shutter and blind are defined here.

Weather Alarm Function

The weather alarms are activated globally on the **Extended settings** tab with the parameter **Global settings for roller shutter and blind**, and the global settings are parameterized there.

There are now 5 different weather alarms available, together with their group objects.

The monitoring of the signals of the activated weather sensors can be carried out cyclically. The device then expects a telegram from the relevant sensor within the cycle time set. If such a telegram is not received within the monitoring time, the associated weather alarm is nevertheless triggered for safety reasons (if, for example, the sensor or the cable connection between sensor and blind channel is defective and no message would be sent in the event of a genuine alarm).

 	Extended settings	Global settings for roller shutter and blind	
		Weather alarm function	Disabled Enabled
		Monitoring time for wind alarm 1	Disabled 1 s ... 12 h
		Monitoring time for wind alarm 2	Disabled 1 s ... 12 h
		Monitoring time for wind alarm 3	Disabled 1 s ... 12 h
		Monitoring time for rain alarm	Disabled 1 s ... 12 h
		Monitoring time for frost alarm	Disabled 1 s ... 12 h

The effect of the **weather alarm functions** can be parameterized here for each channel. You can enable the **weather alarm function** individually for each drive.

	Master / Ext. 1/2	Weather alarm function	
	Output 1+2 / 3+4 / 5 +6 / 7+8 -Blind / roller shutter -Safety and alarm settings	Weather alarm function	Disabled Enabled

With the **weather alarms functions**, you can protect the blinds or roller shutters against adverse weather effects such as wind, rain and frost. In the event of an alarm for one of these 5 possible weather events, the drives move into a safe position and stay there for the duration of the event (depending on the priorities of the other higher-level functions).

New parameters appear for the detailed setting of the **alarm functions** for three wind alarms, one rain alarm and one frost protection alarm.

	Master / Ext. 1/2	Weather alarm function	
	Output 1+2 / 3+4 / 5 +6 / 7+8 -Blind / roller shutter -Safety and alarm settings	React on wind alarm 1	No Yes
		React on wind alarm 2	No Yes
		React on wind alarm 3	No Yes
		Use AND logic for wind alarms	No Yes
		Reaction on wind alarm(s)	Up Down

		Move to position
	Reaction on rain alarm	Disabled
		Stop
		Up
		Down
		Move to position
	Reaction on frost alarm	Disabled
		Stop
		Up
		Down
		Move to position

First select how the drive is to react to an active **weather alarm**. To protect against damage in the case of excessive wind speeds, you can individually assign one of the three wind sensor signals 1, 2 or 3 to each channel. With the respective activation, the three signals of the **wind alarms** are logically "OR" linked or linked by means of the AND parameter.

When a **weather alarm** becomes active, the drive performs one of the following reactions according to your settings:

- **Disabled:** The weather alarm function is not active.
- **Stop:** The drive remains in its current position (stops).
- **Up:** The drive moves to the upper end position. The weather alarm function is switched on and the alarm function is active.
- **Down:** The drive moves to the lower end position. The weather alarm function is switched on and the alarm function is active.
- **Move to position:** The drive moves to the defined safety position. The weather alarm function is switched on and the alarm function is active.

Once the drive has performed the desired reaction, it remains in this position and cannot be operated while the **weather alarm** is active. Only when a function with a higher priority becomes active will the reaction defined there be executed.



If the drive is to move to a specific safety position, you can define this position using parameters:

 Master / Ext. 1/2 Output 1+2 / 3+4 / 5 +6 / 7+8 -Blind / roller shutter -Safety and alarm settings	Weather alarm function	
	Height position at weather alarm in %	0 (0-100)
	Slat position at weather alarm in %	0 (0-100)

This safety position is valid for all three **weather alarms** if you have selected the parameter value "**Move to position**" as the reaction to a **weather alarm**.

Priority of Weather Alarms

The global priorities for the weather alarms are defined here.

 Extended settings 	Global settings for roller shutter and blind	
	Priority of weather alarms	Wind alarm >Rain alarm >Frost alarm
	Monitoring time for wind alarm 1	Rain alarm > Wind alarm > Frost alarm

Monitoring time for wind alarm 2	Rain alarm > Frost alarm > Wind alarm
	Frost alarm > Rain alarm > Wind alarm
	Frost alarm > Wind alarm > Rain alarm

Group Objects for Weather Alarms

No.	Name	Object function	Length	Behavior	Data Type
18	Central	Wind alarm 1	1 bit	Received	1.005 Alarm
19	Central	Wind alarm 2	1 bit	Received	1.005 Alarm
20	Central	Wind alarm 3	1 bit	Received	1.005 Alarm
21	Central	Rain alarm	1 bit	Received	1.005 Alarm
22	Central	Frost alarm	1 bit	Received	1.005 Alarm

Priority of Functions for Roller Shutter and Blind

The global priorities for roller shutter and blind are defined here. The **safety function** has the highest priority. The other priorities can be selected here.

Extended settings	Global settings for roller shutter and blind	
	Priority of functions	Safety > Alarm > Weather alarms > Lock > All other
		Safety > Alarm > Lock > Weather alarms > All other
		Safety > Weather alarms > Alarm > Lock > All other
		Safety > Weather alarms > Lock > Alarm > All other
		Safety > Lock > Alarm > Weather alarms > All other
		Safety > Lock > Weather alarms > Alarm > All other

Calibration

The device calculates the current position of a drive from the running times you have set for the drive and from the control commands it executes. This calculation must be performed because there is no feedback from the drive regarding its position. Even if you have set the running times very precisely, the internally calculated height position will deviate slightly from the actual height position after a number of movements. This is due to mechanical tolerances and weather conditions (temperature fluctuations, frost, rain, etc.).

The device can reset these deviations by means of reference runs. For this purpose, it moves the drives to the upper or lower end position. After the reference run, the internal position calculation starts again from a fixed value. Any deviations that have arisen in the meantime are thus eliminated.

NOTE: The **calibration** function is especially important if you work a lot with position commands and high positioning accuracy is required. If the drives are controlled exclusively using the basic functions and position commands do not matter, then you do not need this function.

The **calibration** function can be activated here in the ETS for all roller shutter/ blind channels.

Extended settings	Global settings for roller shutter and blind	
	Calibration	Disabled Enabled

A reference run can be triggered by a group object or after a certain number of movements.

Group Object for Calibration

No.	Name	Object function	Length	Behavior	Data Type
17	Central	Calibration	1 bit	Received	1.010 Start/Stop

The channel-specific settings for the calibrating function can be found in Calibration, page 98.

PIN Code for Firmware Update

For security reasons, you have to set a valid 4-digit PIN code to block unauthorized updates of the device firmware. The PIN code defined in the ETS has to be entered in the Schneider-Electric Firmware Update Tool before downloading the firmware. This prevents unauthorized firmware update of the device via the USB interface.



Extended settings	PIN Code for Firmware Update Please enter PIN Code for Firmware Update 1234 (4 digits, 0 ... 9)
-------------------	---

PIN codes that are insecure or too simple cannot be selected.

You will receive the following message:

No valid PIN Code for Firmware Update! Please enter a valid PIN Code before you download your configuration!

Device Information



Extended settings	Device information Device info read Firmware master Firmware extension 1 Firmware extension 2 Uptime Master (days/hours/ minutes/seconds)
-------------------	---



If you click **Device info read** button, the firmware version of each device displays.

The **Uptime function** displays the time interval since the last reset of the device.

Express Settings for Switching

On the **Express settings for switching** tab, define basic settings and activate or deactivate other functions.

To switch electrical loads, you can set the channel function of the device to **Switching** mode. The operating mode is selected for each output on the **Defining Channel Functions, page 21 tab**.

	General settings Channel function Master / Extension 1 / Extension 2 Output 1-8 Switching
	 Master/Ext. 1/2 Output 1-8 -Switch: Switching Express settings for switching

Name of the Channel for Switching

You can assign a separate name for each channel, e.g. "Light Hall Ground Floor". This individual name is appended to the fixed channel name, e.g., "**Master Output 1 - Switch**". The full name of the channel is then "Master Output 1 - Switch Light Hall Ground Floor".

The name of the channel now appears on the parameters, channels and associated group objects.

 Master/Ext. 1/2 Output 1-8 -Switch: Switching	Express settings for switching
	Name of the channel <i>Light Hall Ground Floor</i>

Switching Mode

Switching

You can choose between the switching modes **Switching** and **Blinking**. In **Switching** mode, the relay opens and closes depending on the KNX telegram and the setting for the contact mode.

 Master/Ext. 1/2 Output 1-8 -Switch: Switching	Express settings for switching
	Switching mode Switching Blinking
	Contact mode Normally opened Normally closed

The settings for **Output 1** are described below, but apply equally to all outputs.

If you select switching mode **Switching** for output 1 on the master, an ETS channel with the name **Master Output 1 - Switch +Name of the channel** will be created. All the group objects for this output are located there.

Group Objects for Switching Express Settings

No.	Name	Object function	Length	Behavior	Data Type
55	Master Output 1 & (name of the channel)	Switch	1 bit	Received	1.001 Switch
61	Master Output 1 & (name of the channel)	Feedback	1 bit	Sending	1.001 Switch

Contact Mode Normally Opened

The settings for Output 1 are described below, but apply equally to all outputs.

 Master/Ext. 1/2 Output 1-8 -Switch: Switching	Express settings for switching
	Contact mode Normally opened Normally closed

If the **switch object** receives a telegram with the value “0”, the contact is opened. If a telegram value of “1” is received, the contact is closed.

The settings “**Pressed**” and “**Released**” are used for the different switching states of the output contacts.

In relay mode “**Normally opened**”:

- Pressed = contact closed
- Released = contact opened

Switching (*Normally opened mode*)

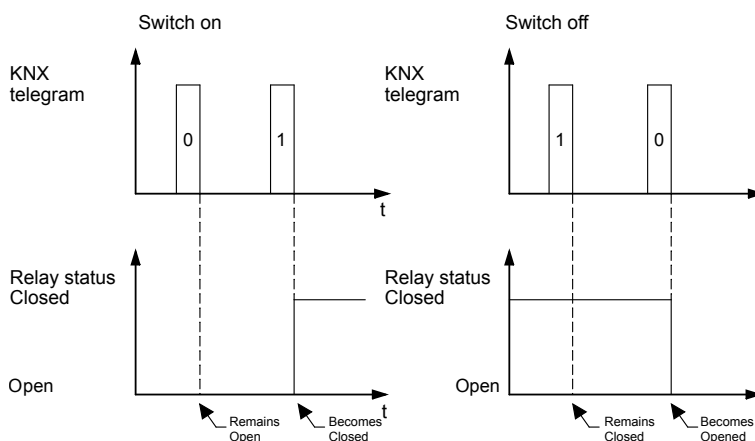

Status Response

Depending on the parameterization, each channel can return a status response. The following parameter settings are available for this:

Normal behavior (Pressed = 1; Released = 0)

Inverted (Pressed = 0; Released = 1)

Contact Mode Normally Closed

If the **switch object** receives a telegram with the value “0”, the contact is closed. If a telegram value of “1” is received, the contact is opened. The settings “**Pressed**” and “**Released**” are used for the different switching states of the output contacts.

In relay mode **Normally closed**:

- Pressed = contact opened
- Released = contact closed

Switching (**Normally closed mode**)

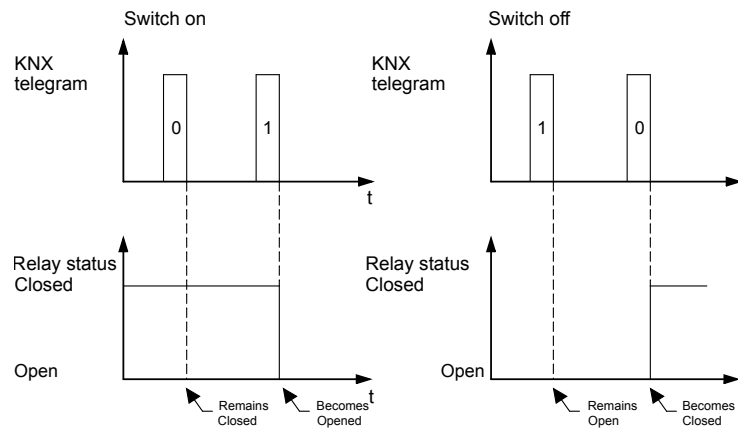

Status Response

Depending on the parameterization, each channel can return a status response. The following parameter settings are available for this:

Normal behavior (Pressed = 1; Released = 0)

Inverted (Pressed = 0; Released = 1)

Blinking

The switching mode **Blinking** alternately opens and closes the relay. You can define the blinking behavior for each channel. The blinking speed is defined using the parameter **Blinking interval**. The blinking cycle starts with a closed relay.

Furthermore, you can set the ratio between closed and open relay during a blinking time in 3 steps. You can reduce the blinking intervals to a defined number to protect the relay. Additionally, you can specify the state to which the relay will be switched after the defined number of blinking intervals.

IMPORTANT: Short switching times must not be parameterized under load (see technical data of the switching output).

 Master/Ext. 1/2 Output 1-8 -Switch: Switching	Express settings for switching	
	Switching mode	Blinking
	Behavior at pressed/released	Blinking / relay opened
		Blinking / relay closed
		Relay opened / blinking
		Relay closed / blinking
Blinking interval	5 s	

	(5 s - 60 s)
Proportion open/closed	Equal (50/50%) Short open / long closed (20/80%) Long open / short closed (80/20%)
Defined number of blinking intervals (0...255, 0 = permanent blinking)	20
Behavior after defined number of blinking intervals	Relay is closed Relay is opened

Behavior at Pressed/Released

- Blinking/relay opened**

With **pressed** (telegram value "1"), the relay starts blinking. With **released** (telegram value "0" during blinking), the relay stops blinking and the relay is opened.

Blinking/relay opened

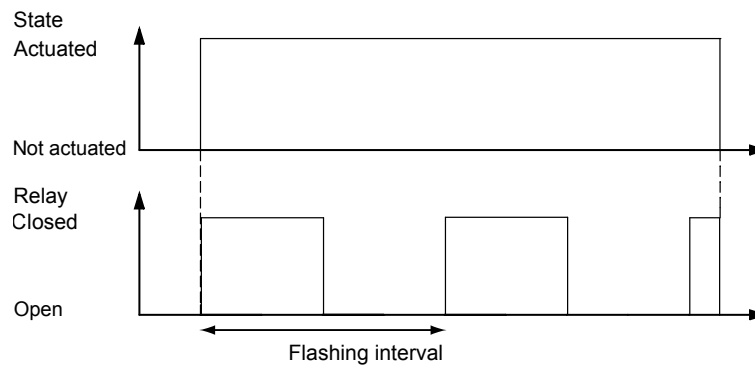

- Blinking/relay closed**

With **pressed** (telegram value "1"), the relay starts blinking. With **released** (telegram value "0" during blinking), the relay stops blinking and the relay is closed.

Blinking/relay closed

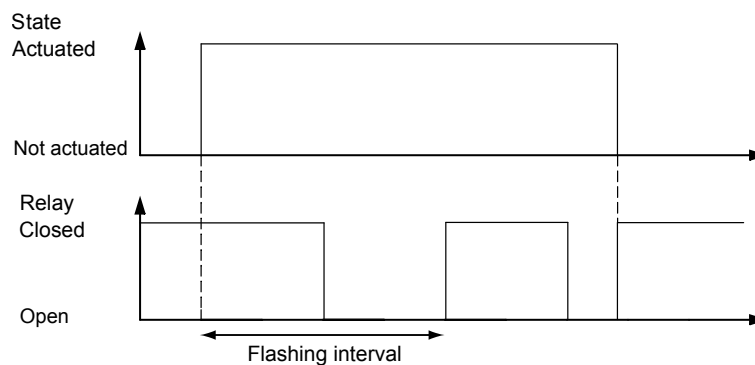

- Relay opened/blinking**

With **pressed** (telegram value "1"), the relay stops blinking and the relay is opened. With **released** (telegram value "0" during blinking), the relay starts blinking.

The blinking cycle starts with a closed relay immediately after the download. Following the download, the switch object is released.

Relay opened/blinking

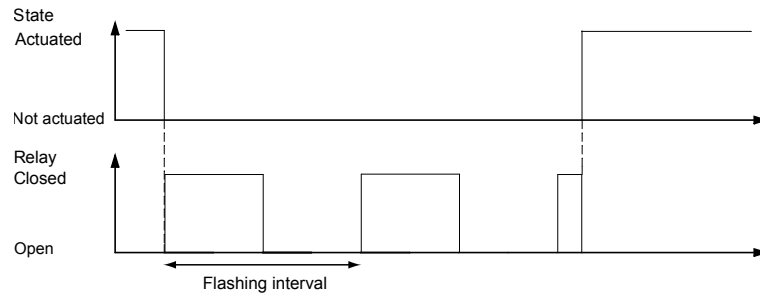

- **Relay closed/blinking**

With **pressed** (telegram value “1”), the relay stops blinking and the relay is closed.
 With **released** (telegram value “0” during blinking), the relay starts blinking.

The blinking cycle starts with a closed relay immediately after the download.
 Following the download, the switch object is released.

Relay closed/blinking

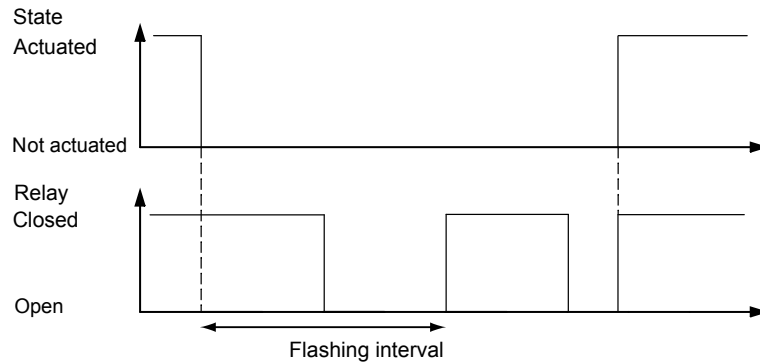

Blinking Interval

The blinking speed is set here. A blinking interval (on/off) can be set between 5 and 60 seconds.

Proportion Open/Closed

You can parameterize the ratio between closed and open relay during a blinking time.

You can select whether the relay is to be open/closed equally (**Equal**) during a blinking interval (50%/50%) or **short open/long closed** (20% / 80%) or **long open/short closed** (80%/20%).

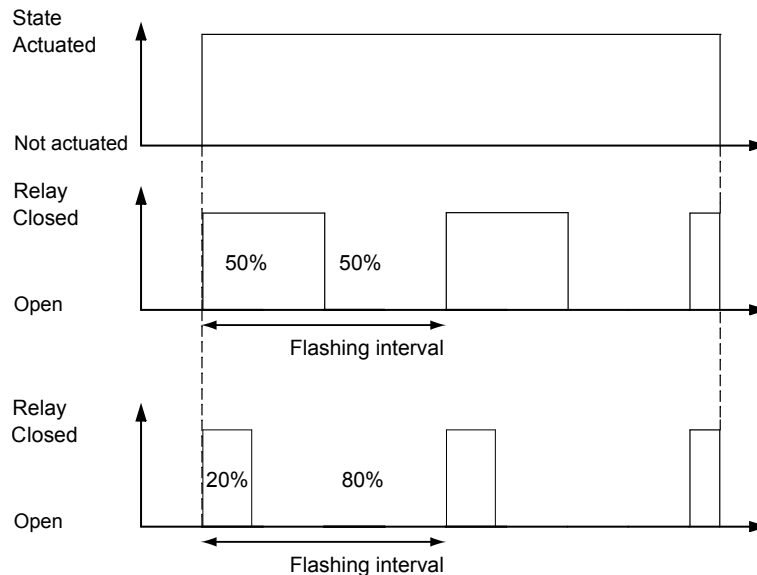
Proportion open/closed**Defined Number of Blinking Intervals**

You can reduce the blinking intervals to a defined number (0...255) to protect the relay.

With "0", the number of blinking intervals is unlimited, so the relay blinks permanently.

Behavior after Defined Number of Blinking Intervals

You can specify the state to which the relay will be switched after the defined number of blinking intervals.

Either **Relay is closed** or **Relay is opened**.

Status Response

Depending on the parameterization, each channel can return a status response. The following parameter settings are available for this:

Normal behavior (Pressed = 1; Released = 0)

Inverted (Pressed = 0; Released = 1)

NOTE: At the beginning of the blinking interval, a one-off "1" signal is sent as feedback to the bus. After the end of the blinking interval, a one-off "0" telegram is sent to the bus. Or inverted.

Group Objects for Switching Express Settings

No.	Name	Object function	Length	Behavior	Data Type
55	Master Output 1 & (name of the channel)	Switch	1 bit	Received	1.001 Switch
61	Master Output 1 & (name of the channel)	Feedback	1 bit	Sending	1.001 Switch

Operating Hours Counter

The **Operating hours counter** is a feature in the SpaceLogic KNX, Secure, Switch/Blind Master device that helps you track how long a relay or motor has been running.

Runtime values are stored persistently, so they survive power loss or device restart.

NOTE: This feature is available only on devices running **firmware version 4.0 or higher**.

 Master/Ext. 1/2 Output 1 - 8 -Switch Switching 	Express settings for switching	
	Operating hours counter	Enabled
	Overwrite operating hours limit during download	Disabled/ Enabled
	Operating hours limit	1 ... 65535

Key Features

- Track runtime per channel**
 Check the total operating time of each channel directly in your KNX visualization or ETS software. The counter increases only when the relay is actively switched on.
- Persistent storage**
 Runtime values are stored persistently, surviving power loss or device restart. The initial value is always 0, unless manually set via a dedicated group object.
- Maintenance alerts**
 Set a runtime limit (e.g., 5000 hours). When the device reaches this threshold, it sends an alarm notification. You can reset or acknowledge it by writing to the reset object.

Reset after equipment replacement
 Use a reset object to start the counter from zero, making it easy to manage maintenance cycles.
- Manual runtime adjustment**
 Update the runtime manually (e.g., after replacing a lamp) using a dedicated object—no need to re-download the ETS project.
- Fixed reporting interval**
 The counter value is sent either when the runtime increases by one hour or after device startup.

Group Objects

- Operating hours** object shows current runtime.
- Operating hours limit set** object allows manual setting of the runtime limit. A written value takes priority over the parameter. If the value written is zero, the object reverts to the parameter-defined limit.
- Operating hours limit reached** object – ON when runtime exceeds limit.
- Operating hours limit reset** object resets runtime to 0. This object also resets the alarm (**Operating hours limit reached**).

Name	Object function	Length	Behavior	Data Type
Master Output Nr. – Switch Name of the channel	Operating hours	4 bytes	Sends	13.100 time lag (s)
Master Output Nr. – Switch Name of the channel	Operating hours limit set	2 bytes	Receives	7.007 time (h)
Master Output Nr. – Switch Name of the channel	Operating hours limit reached	1 bit	Sends	1.005 alarm
Master Output Nr. – Switch Name of the channel	Operating hours limit reset	1 bit	Receives	1.015 reset

Use Cases

Lighting Maintenance in Residential Projects

Track how long lights have been on. When the runtime exceeds a set value (e.g., 5000 hours), an alarm is triggered. After replacing the lamp, the counter can be reset without needing to reprogram the device.

Facility Management in Commercial Buildings

Maintenance teams can monitor runtime across multiple devices and plan replacements or inspections based on actual usage, improving efficiency and reducing downtime.

Energy Monitoring in Smart Homes

Homeowners can track how long specific circuits or appliances have been active, helping them understand usage patterns and optimize energy consumption.

Scenes

If you want to change multiple room functions simultaneously at the press of a button or with a command, you can do so using the scene function.

You can use a scene, for example, to switch on the room lighting, set the heating control to daytime operation and turn on the power supply for the sockets of a room.

Enable Scenes

 Master/Ext. 1/2 Output 1-8 -Switch: Switching	Express settings for switching	
	Scenes	Disabled <input type="checkbox"/> Enabled <input type="checkbox"/>
	 Scene settings	

Number of Scenes

 Master/Ext. 1/2 Output 1-8 -Switch: Switching	Scene settings	
	Scenes settings	Required number of scenes 1 (1 – 16)

You can use the scene function to include multiple channels in a scene control. Up to 16 different scenes are available for each output channel.

Each of the 16 scenes can be disabled again.

 Master/Ext. 1/2 Output 1-8 -Switch: Switching	Scene settings	
	Scenes settings	Scene 1 (1-16) Disabled Enabled Scene 1 Description Scene 1 Address (0-63) Scene address 0 - 63 Dependent: Global Settings for Scenes, page 27 Scene 1 Address (1-64) Scene address 1 - 64 Dependent: Global Settings for Scenes, page 27 Scene 1 switching state Released Pressed

For clarity, a short description can be stored for each scene.

Each of these scenes can be assigned one of 64 possible scene addresses 0 to 63 (corresponding to telegram values 0-63) or 1 to 64 (corresponding to telegram values 0-63). This depends on the global settings for scenes.

Global Settings for Scenes, page 27

You can store the switching states (pressed, released) as scene values for each output channel.

Time Delay for Scene Processing

To avoid high power-on currents when switching to a complex scene, you can parameterize a time delay for each output channel.

 Master/Ext. 1/2 Output 1-8 -Switch: Switching	Scene settings	
	Scenes settings	Time delay for scene processing 0 (0...255, unit = 100 ms)

Calling and Saving Scene Values

The scene values for the output relays are called using the “**Scene**” object. After receiving a scene telegram, the device evaluates the sent scene address and switches the outputs to the saved scene values.

If the “**scene**” object receives a scene telegram with learning bit “1”, then for all scenes assigned to the received scene address, the current switching state is saved as the new scene value.

NOTE: If a scene address within a channel is assigned to multiple scenes (incorrect parameterization), only the last scene found with this scene address is called or saved. You can avoid this by assigning different scene addresses within a channel.

Telegram format

Telegrams for the scene function have the data format: L X D D D D D D.

L = learning bit

X = not used

DDDDDD = called scene address

If the learning bit in a telegram has the value “0”, then the relay states saved for the scene address are called and set.

If the learning bit receives the value “1”, then the current output states are saved as new scene values for the received scene address.

Examples:

Telegram value	Binary	Hexadecimal	Scene address
0	0000 0000	0	Call scene address 0
1	0000 0001	1	Call scene address 1
29	0001 1101	1D	Call scene address 29
57	0011 1001	39	Call scene address 57
63	0011 1111	3F	Call scene address 63
128	1000 0001	80	Learning scene address 0
129	1000 0001	81	Learning scene address 1 (129-128)
157	1001 1101	9D	Learning scene address 29 (157-128)
185	1011 1001	B9	Learning scene address 57 (185-128)
191	1011 1111	BF	Learning scene address 63 (191-128)

Overwrite Scene Values during Download

 Master/Ext. 1/2 Output 1-8 -Switch: Switching	Scene settings	
	Scenes settings	Overwrite scene values of actuator during download Enabled Disabled

If you have enabled the parameter “**Overwrite scene values in actuator during download**”, the scene values saved in the device will be overwritten with your preset values on downloading.

If you do not want to overwrite the values in the device when downloading, you must disable the parameter. In this case, the parameterized scene values are only written to the device memory during the first download.

If an application download is then carried out, the scene values in the device memory are retained.

Priority

The scene function has the same priority as the normal switching function via the “switch object”. This should be taken into account with regard to the priority of the higher-level functions.

Group Object for Scene

No.	Name	Object function	Length	Behavior	Data Type
60	Master Output 1 & (name of the channel)	Scene	1 byte	Receives	18.001 Scene control

Central Function for Switching

The central function is enabled or disabled here for each switch output.

 Master/Ext. 1/2 Output 1-8 -Switch: Switching	Express settings for switching	
	Central function	Enabled Disabled

The global settings and explanations of the central function can be found in the chapter [Enabling Central Functions](#), page 23.

Status Response

Depending on the parameterization, each channel can return a status response. The following parameter settings are available for this:

Normal behavior (Pressed = 1; Released = 0)

Inverted (Pressed = 0; Released = 1)



Activating Extended Settings for Switching

To activate the advanced settings for switching, you must enable them here.

 Master/Ext. 1/2 Output 1-8 -Switch: Switching	Express settings for switching	
	Extended settings for switching	No Yes

Extended Settings for Switching

On the **Express settings for switching** tab, activate the **Extended settings for switching**.

 Master/Ext. 1/2 Output 1-8 -Switch: Switching	Express settings for switching	
	 Extended settings for switching	Disable Enable
	– Time settings	Staircase lighting time
		On-delay time
		Off-delay time
	– Logic, Locking & Priority settings	Priority function
		Logic function
	– Safety and alarm settings	Safety function
		Alarm function
		Failure and download behavior

Time Settings

Staircase Lighting Time Function (Staircase Timer)

This function is used to switch on an appliance, e.g., the light in a staircase, via a bus telegram and automatically switch it off again after a set duration. Therefore, no manually or automatically generated bus telegram is required for switching off. The actuator carries out the switching off operation independently and under time control.

Two types of staircase lighting time function are available:

 Master/Ext. 1/2 Output 1-8 -Switch: Switching	Staircase lighting time	
	– Time settings	Staircase lighting time
		Disabled Fix Variable

Following enabling of the corresponding staircase lighting time function, the relevant group object appears.

Staircase Lighting Time Fix

With **Staircase lighting time fix**, you can parameterize a fixed staircase lighting time for each channel. The staircase lighting time can be parameterized between 5 seconds and 1 hour. This function makes the **Staircase fix** object (1 bit) available to you.

 Master/Ext. 1/2 Output 1-8 -Switch: Switching	Staircase lighting time fix
--	------------------------------------

- Time settings ↻	Manual switching off	Active Not active
	Time extension	Not retriggerable Retriggerable Retriggerable and adding
	Max. number of additions	2 (2 - 5)
	Duration time	2 min (5 s - 1 h)
	Number of prewarnings	0 (0 - 5)
	Warning starts (5...255, unit = 1s) before end	20 (5 - 255)
	Hint: Staircase duration time must be longer or equal than prewarning start time.	

Staircase Lighting Time Variable

With **Staircase lighting time variable**, a time between 0 s and 65 535 s is defined via the object **Staircase variable** (2 bytes DPT 7.005 time (s)), e.g. using a button. This enables you to specify the length of the staircase lighting time from different places depending on the desired situation.

Master/Ext. 1/2 Output 1-8 -Switch: Switching - Time settings ↻	Staircase lighting time variable	
	Manual switching off	Active Not active
	Time extension	Not retriggerable Retriggerable Retriggerable to the higher value Retriggerable and adding
	Max. number of additions	2 (2 - 5)
	Number of prewarnings	0 (0 - 5)
	Warning starts (5...255, unit = 1s) before end	20 (5 - 255)
	Hint: Staircase duration time must be longer or equal than prewarning start time.	

Manual Switching off

Both staircase lighting time functions enable you to switch off the staircase lighting time prematurely. After receiving the object value **0**, the output is switched to the **released** position.

Manual switching off = Active ("0" telegram)

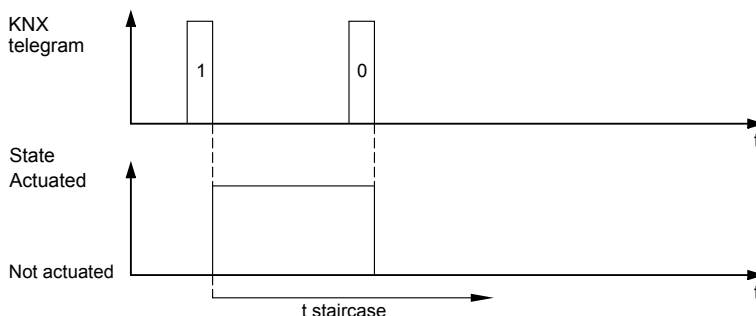

Manual switching off = Not active ("0" telegram)

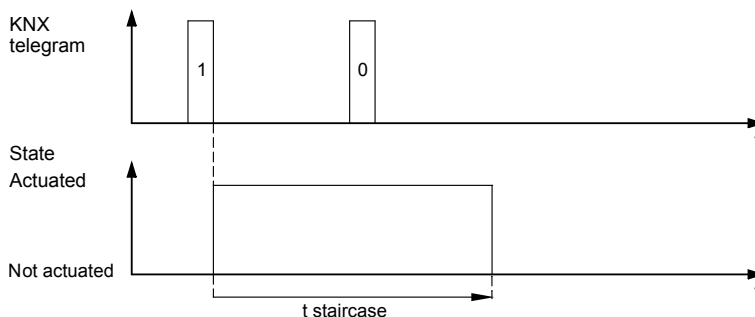

A telegram with the object value 0 has no effect. The set staircase light time continues to run normally until the end.

Time Extension

If you want to restart the staircase lighting time before it has elapsed or add up the staircase lighting time, you must select the staircase lighting time **Retriggerable** or **Retriggerable and adding** or **Retriggerable to the higher value**. The staircase lighting time is then restarted or added using another "1" telegram.

Time extension = Retriggerable

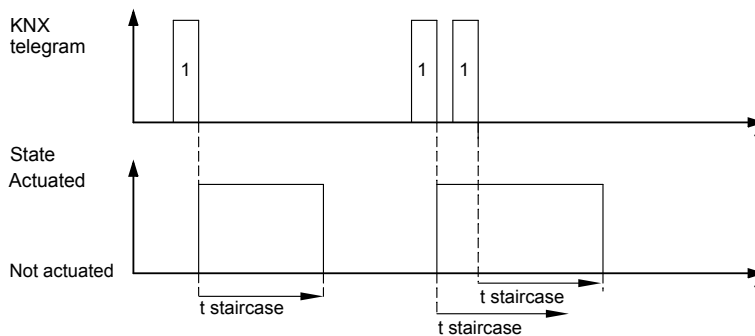

Once a new telegram with the object value "1" has been received, the staircase lighting time is restarted.

Time extension = Retriggerable and adding

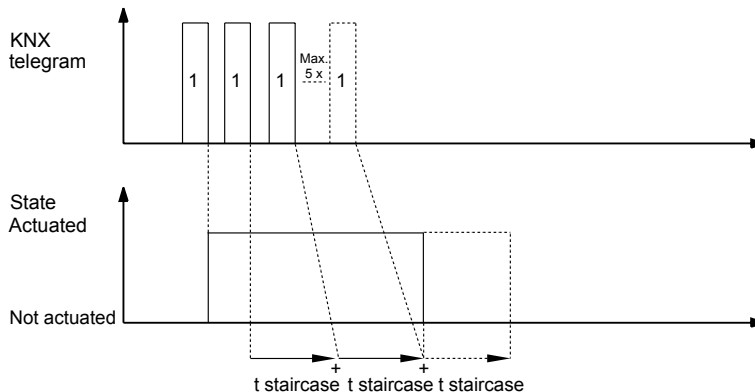

Once one or more new telegrams with the object value "1" have been received, the staircase lighting time is added to the previous staircase lighting time. The number of additions can be set. You can parameterize a maximum of 5 additions of the staircase lighting time.

For example, you can add up the staircase lighting time by pressing a separate button several times.

Time extension = Retriggerable to the higher value (only for staircase lighting time = variable)

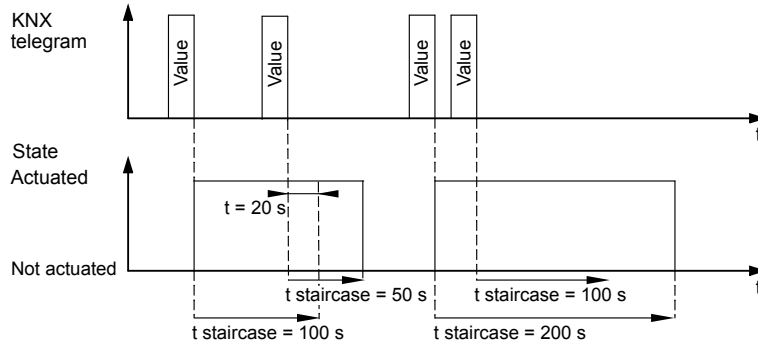

Once a new telegram has been received, the staircase lighting time is restarted with the higher value.

Time extension = Not retriggerable

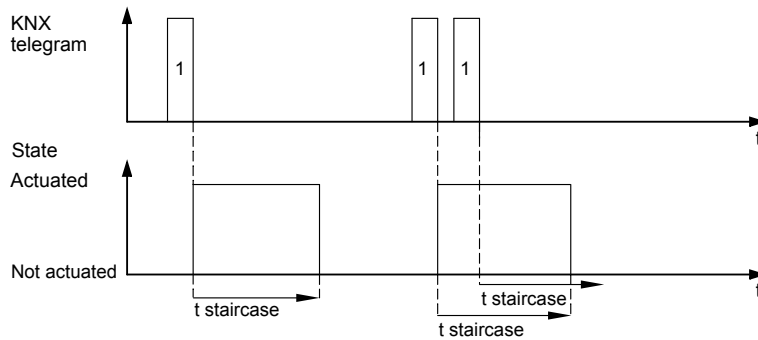

However, if the staircase lighting time is not retriggerable, the relay will switch off at exactly the moment the time elapses.

If the **Manual switching off** function is activated, the staircase timer can be ended with a “0” telegram.

Prewarnings

To ensure that you are warned before the end of the staircase lighting time, you can parameterize a defined number (0-5) of prewarnings.

With the prewarnings, the user can be informed about the imminent end of the function by briefly switching off the lighting system shortly before the end of a staircase lighting time. He can then restart the staircase lighting by pressing a button (retriggering). If he does nothing, the function continues normally.

You can set this using the parameter **Number of prewarnings**. With the value “0”, the warning function is disabled. To enable the prewarnings, select the number of warning pulses. The first warning starts at the remaining staircase lighting time ($t_{warning}$) set via the parameter **Warning starts before end**.

With every prewarning, the output contact is switched to “released” state for the fixed duration of 500 ms (t_u). If you have activated more than one warning, the waiting time (t_{zv}) between the warning pulses is calculated using the following formula:

$$\begin{aligned}
 \text{Wait time between prewarnings } (t_{zv}) &= \frac{\text{Remaining staircase lighting time } (t_{warning}) - (\text{number of prewarnings} \times 500 \text{ ms } (t_u))}{\text{Number of prewarnings}}
 \end{aligned}$$

If a continuous staircase lighting time function is interrupted by premature termination, no prewarning is given

Prewarning (number of prewarnings=3)

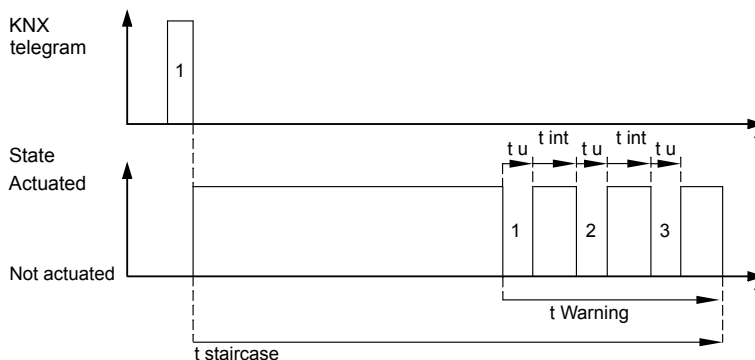

Staircase Lighting Time Function in Combination with On-delay and Off-delay

Combining a staircase lighting time function with an on-delay results in a delayed start of the staircase lighting function.

Staircase lighting time function with on-delay

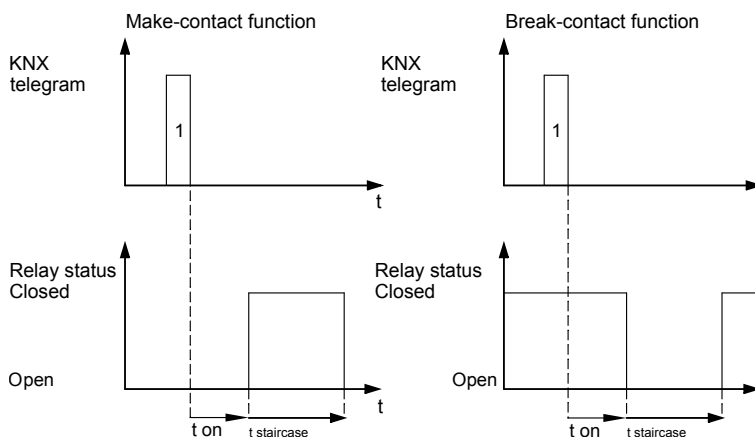

The result of combining a staircase lighting time function with an off-delay depends on how you have defined the **staircase lighting time function**:

In the case of the staircase lighting time function with **manual switching off** ("0" telegram), the off-delay is started if a premature switch-off telegram is received on the **"staircase lighting time object"**. Once the off-delay time has elapsed, the output is switched off (released).

In the case of the staircase lighting time function without **manual switching off**, receipt of a switch-off telegram on the **"staircase lighting time object"** has no effect. The staircase lighting time function continues to the end and then switches the output relay directly to the "released" state. An off-delay cannot be set.

Staircase lighting time function with off-delay

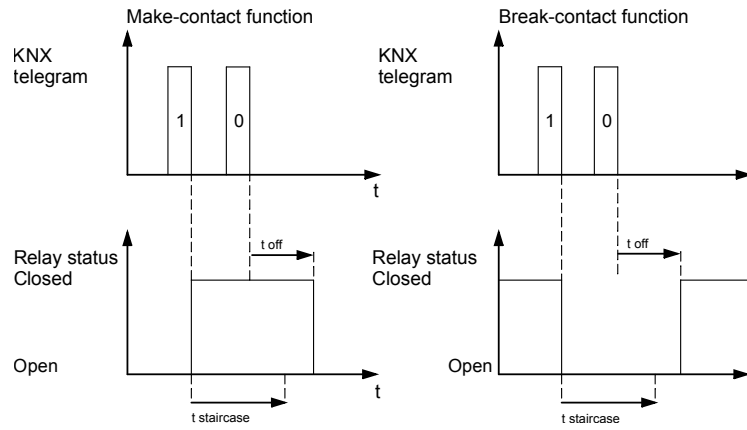

For staircase lighting time functions with **manual switching off** and warnings activated, the staircase lighting time function is immediately deactivated with a warning when an “Off” telegram is received. The off-delay elapses. No warning is generated.

Priority

If the output of the actuator is switched to a new switch position by a higher priority function during an ongoing staircase lighting time, the relay switches to the new position immediately. The most recent switching telegram is saved and delay times and staircase lighting times continue.

Group Objects for Starcaise Lighting Time

No.	Name	Object function	Length	Behavior	Data Type
59	Master Output 1 & (name of the channel)	Staircase fix	1 bit	Receives	1.010 Start/Stop
59	Master Output 1 & (name of the channel)	Staircase variable	2 bytes	Receives	7.005 Time (s)

On-delay and Off-delay

Due to the delay functions, the change of relay states is not carried out immediately after receipt of a telegram, but only after the set delay time has elapsed:

After the object value “1” has been received, the on-delay delays the switching of the relay contact from the **released** state to the **pressed** state.

After the object value “0” has been received, the off-delay delays the switching of the relay contact from the **pressed** state to the **released** state.

You can also use both functions together with a single channel.

Objects

For each channel, you can parameterize whether the delay affects the switch object, staircase lighting time object or scene object, or multiple objects in combination.

On-delay and off-delay (normally opened/normally closed)

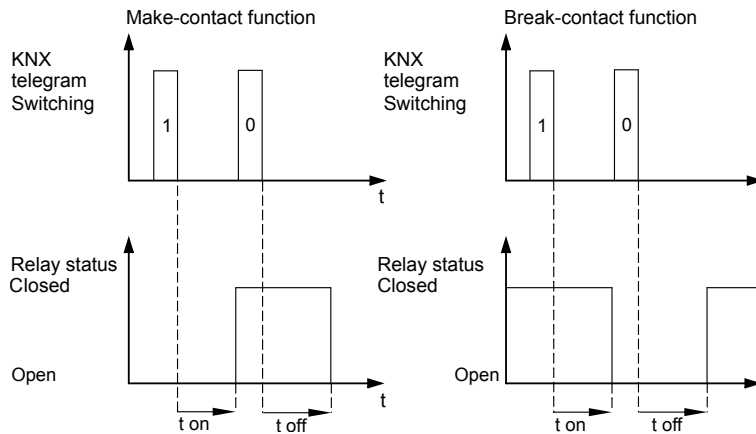

On-delay

✕ Master/Ext. 1/2 Output 1-8 -Switch: Switching – Time settings	On-delay time	Enabled
		Disabled
	Works on Switch object	Yes (Yes/No)
	Works on Staircase object	No (Yes/No)
	Works on Scene object	No (Yes/No)
	On-delay mode	Not retriggerable
		Retriggerable
	On-delay time	1 s (0 ms-1 h)

Off-delay

✕ Master/Ext. 1/2 Output 1-8 -Switch: Switching – Time settings	Off-delay time	Enabled
		Disabled
	Works on Switch object	Yes (Yes/No)
	Works on Staircase object	No (Yes/No)
	Works on Scene object	No (Yes/No)
	Off-delay mode	Not retriggerable
		Retriggerable
		Retriggerable and adding
Max. number of additions	2 (2-5)	
On-delay time	1 s (0 ms-1 h)	

Type of Delay

Delay times can be parameterized for each channel. You can use parameters to define the set delays as **Retriggerable** or **Not retriggerable**. In the case of a retriggerable on-delay, the delay time is restarted when a “1” telegram is received.

In the case of retriggerable off-delays, the delay time is restarted when a “0” telegram is received.

Retriggerable on-delay (“1” telegram)

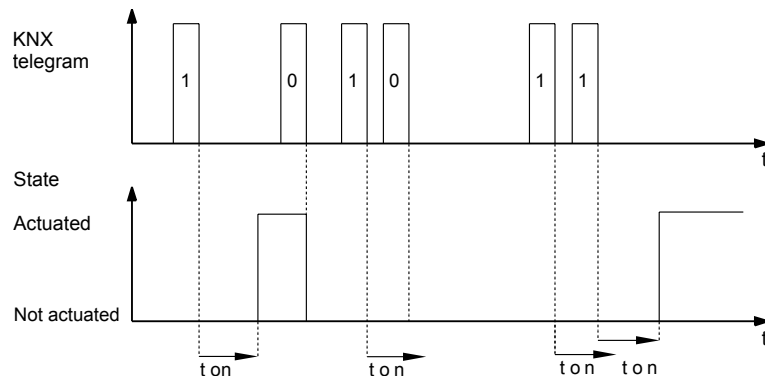

Retriggerable off-delay (“0” telegram)

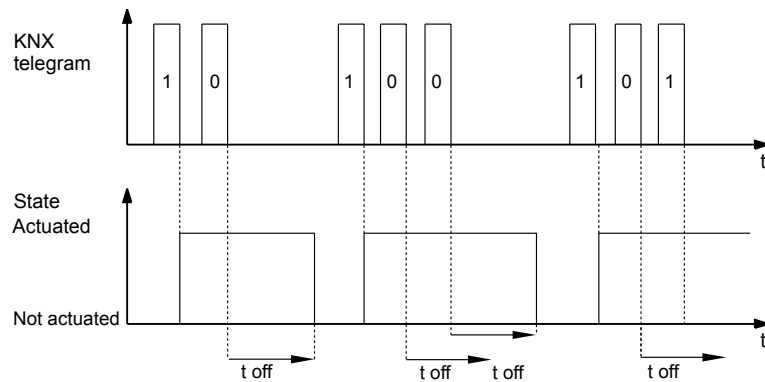

Moreover, for the off-delay, you can also select **Retriggerable and adding**. The delay time is added when the same telegram value is received, e.g. using a separate button. You can define the maximum number of additions.

Retriggerable off-delay and adding (“0” telegram)

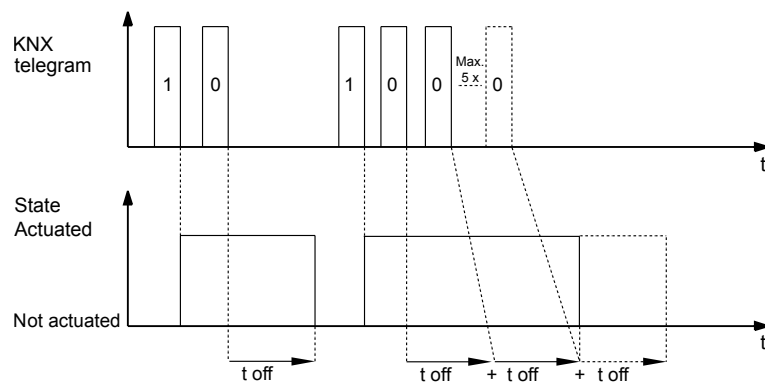

In the case of not retriggerable delays, by contrast, the relay will switch off at exactly the moment the time elapses.

Not retriggerable on-delay

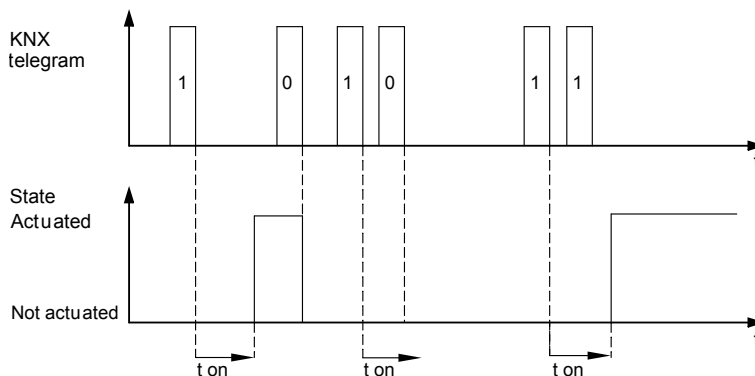

Not retriggerable off-delay

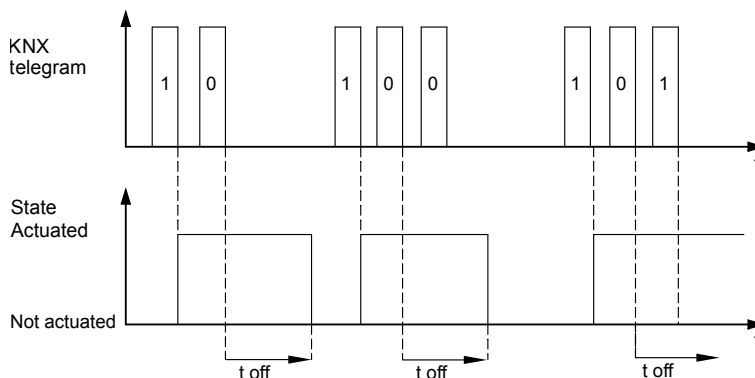

Interrupting a Delay Function

If a delay function is started by receiving a new object value and the output channel receives a telegram with the opposite object value during the current delay time, the delay function is canceled. The relay is not switched:

- Receipt of the object value “0” interrupts an active on-delay.
- Receipt of the object value “1” interrupts an active off-delay.

Priority

If the output of the actuator is switched to a new switch position by a higher-level function during an active delay time, the relay switches immediately.

Logic, Locking and Priority Settings

Logic Function

With this functionality, the **Switching** object and the **Logical input** object can be logically linked to one another.

The logic function can be activated (enabled) in the ETS.

 Master/Ext. 1/2 Output 1-8 -Switch: Switching – Logic, Locking & Priority settings	Logic function	
	Logic function	Disabled Enabled

Type of logic operation	OR
	AND
	XOR
Value of logic operation object after bus voltage recovery or download	0
	1
Value of logic object	Normal
	Inverted

An **AND**, **OR** or **XOR** logic operation can be set. A parameter is used to define the preset value of the logic object after bus voltage recovery and download.

For example, in the case of an OR logic object preset with the value “1” after bus voltage recovery, the output remains activated until a “0” telegram is received on the “logic object”. A parameterized behavior after bus voltage recovery is only adopted after the logic operation has been terminated.

AND Logic Operation

As long as the “**logical input object**” has the value “1”, switching can be carried out as usual using the address of the “**switch object**”. Set staircase lighting times will continue to be observed. Switching off via the “logic object” takes effect immediately.

Object Logical input	Object Switching	Result
0	0	0
0	1	0
1	0	0
1	1	1

Example:

An AND logic operation can be used to create a power-on lock. This means that as long as the value of the “logic object” is “0”, the “switch object” cannot be used for switching on. If the value of the “switch object” is “1”, switching on is carried out automatically if the value of the logic object changes from 0 to 1.

*AND logic operation;
Value of logic object after bus voltage recovery: 1*

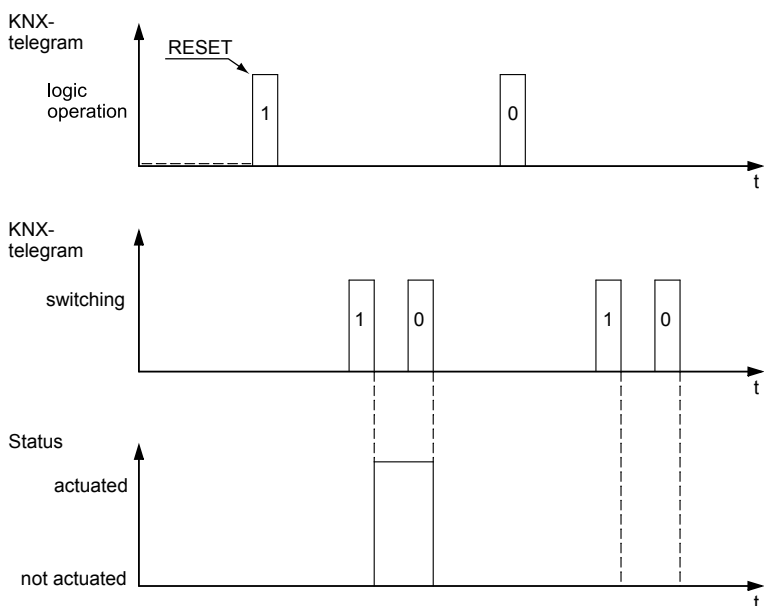

The logic object is preset with the value "1" after a RESET (bus voltage recovery and download). This enables switching to be carried out as usual using the switch object. The power-on lock is not active until a "0" telegram has been received via the logic object.

AND logic operation;

Value of logic object after bus voltage recovery: 0

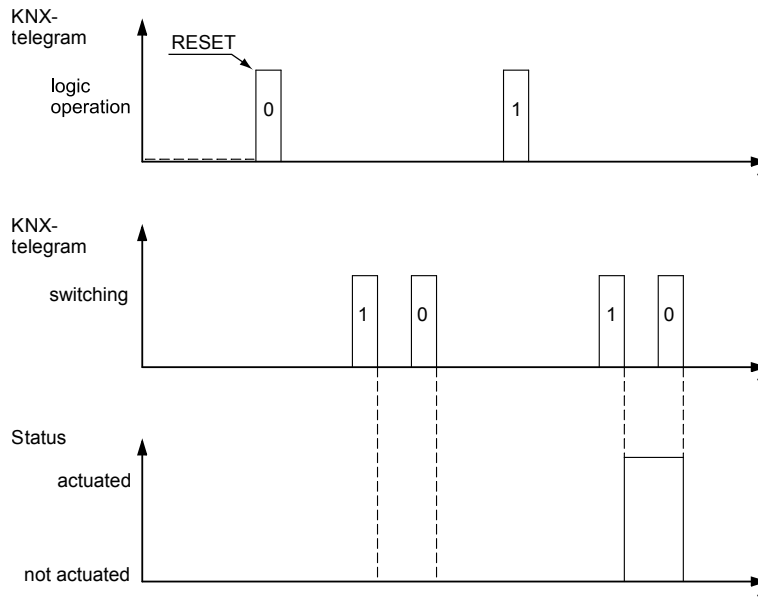

The parameter setting causes the "logic object" to be set to the value "0". After a RESET, the actuator does not switch the output until a "1" telegram has been received on the "logic object".

OR Logic Operation

As long as the "logic object" has the value "0", switching can be carried out as usual using the address of the "switch object". Set staircase times continue to be observed. Switching on via the "logic object" takes effect immediately.

Object Logical input	Object Switching	Result
0	0	0
0	1	1
1	0	1
1	1	1

Example:

An OR logic operation can be used to implement a power-off lock or Central ON function (e.g. light for cleaning buildings). If the value of the "switch object" is also set to "1" locally, the relay remains switched on when the power-off lock is withdrawn (value change of logic object from 1 to 0).

*OR logic operation;
Value of logic object after bus voltage recovery: 0*

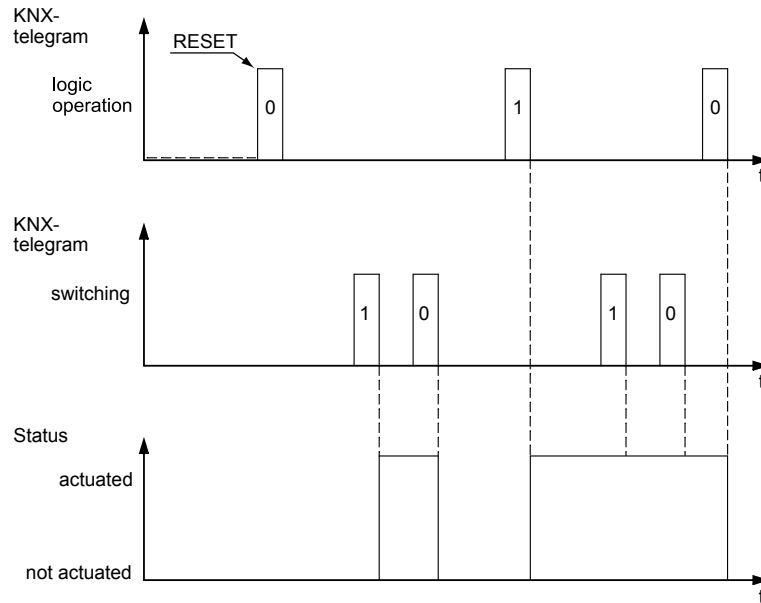

*OR logic operation;
Value of logic object after bus voltage recovery: 1*

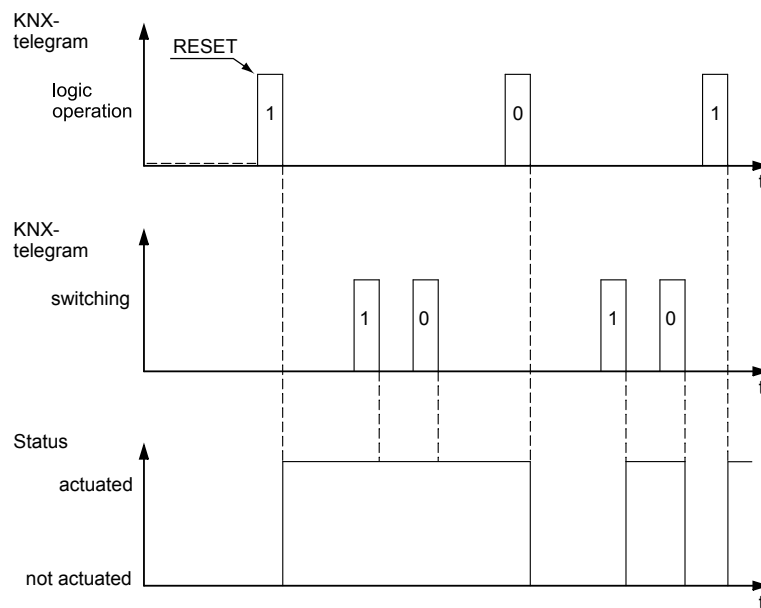

The logic object is preset to the value "1" after a RESET. The actuator will switch on the output immediately. The OR logic function is only reset by a "0" telegram on the logic object.

XOR Logic Operation

As soon as the values of the "logic object" and the "switch object" differ from one another, the output is switched to **Pressed**. If the values are the same, the output is **Released**.

Object Logical input	Object Switching	Result
0	0	0
0	1	1
1	0	1
1	1	0

Group Objects of Logic Function

No.	Name	Object function	Length	Behavior	Data Type
55	Master Output 1 & (name of the channel)	Switch	1 bit	Received	1.001 Switching
56	Master Output 1 & (name of the channel)	Logical input	1 bit	Received	1.002 Boolean

Functions with Higher Priority

The order of priority of the various functions is set on the **Extended settings** tab of the device.

Priority of Functions for Switching, page 32

In the ETS, the higher priority function can be activated.

 Master/Ext. 1/2 Output 1-8 -Switch: Switching – Logic, Locking & Priority settings	Priority function	
	Higher priority function	Disabled Priority function Locking function

Priority Function (Priority Control)

If you have chosen the priority function (known in other devices as priority control), a new group object called **Priority** is available for this channel.

 Master/Ext. 1/2 Output 1-8 -Switch: Switching – Logic, Locking & Priority settings	Priority function	
	Higher priority function	Priority function
	Behavior at end of priority	Follows current value Pressed Released
	Behavior after bus voltage recovery	Disabled Enabled, released Enabled, pressed As before bus voltage failure

The object values of the priority object have the following meaning:

Value bit 1	Value bit 2	Behavior of output
1	1	Activate priority, switching state "Pressed"
0	1	Deactivate priority, switching state dependent on the parameter Behavior at end of priority
1	0	Activate priority, switching state "Released"
0	0	End of priority, switching state dependent on parameter Behavior at end of priority

The priority is activated if the value “1” is received on bit 1. The assigned output relay is then switched, depending on bit 2, to “Pressed” (bit 2 = “1”) or “Released” (bit 2 = “0”).

An active priority is deactivated by a new telegram with the value “0” on bit 1. As long as a priority function is active, the channel concerned cannot be controlled by the “switch object” and the advanced functions (central function, time functions, scene function).

After the end of a priority, the behavior of the output relay is determined by the parameter **Behavior at end of priority**.

The setting **Follows currently valid state** has the following effect:

During the active priority, all switching commands of subordinate functions are tracked by the application and the switching state is tracked internally. In this way, at the end of the priority, the switching state can be set that would currently have been set without the priority.

Behavior After Bus Voltage Recovery

Using the parameter **Behavior after bus voltage recovery**, you can define the reaction of the channel to bus voltage recovery and the switching state:

Disabled

Priority remains deactivated. The switching state of the channel results from the other higher-level functions or from the set switching behavior after bus voltage recovery.

Enabled, released

The priority is automatically activated on bus voltage recovery and the switching state is switched to **Released**.

Enabled, pressed

The priority is automatically activated on bus voltage recovery and the switching state is switched to **Pressed**.

As before bus voltage failure

The priority is brought to the state it had before the bus voltage failure. If the priority was previously active, the output relay is switched to the state it had previously.

Group Object for Priority Function

No.	Name	Object function	Length	Behavior	Data Type
57	Master Output 1 & (name of the channel)	Priority	2 bit	Received	2.001 Prio. switching

Locking Function

You can use the locking function to set a specific channel to pressed/released and lock it in this position. The state of the output channel cannot be changed by other control commands as long as the lock is active. You can enable the locking function individually for each switching channel.

	Master/Ext. 1/2 Output 1-8 -Switch: Switching	Locking function
---	---	-------------------------

– Logic, Locking & Priority settings	Higher priority function	Locking function
	Locking	At object value "1" At object value "0"
	Behavior at start of locking	No reaction Pressed Released
	Behavior at end of locking	No reaction Pressed Released Follows current value
	Behavior after download	Disabled Enabled As before download
	Behavior after bus voltage recovery	Disabled Enabled As before bus voltage failure

Once the locking function has been enabled, a new group object called **Lock** is available for the switching channel. You can activate and deactivate a channel lock using the **locking object**.

If the **locking object** receives a telegram with the object value that you set for the parameter **Lock**, all other channel functions are disabled. You can define the reaction using the parameter **Behavior at start of locking**.

If the locking object receives a telegram with the object value opposite of that for activation, the lock is canceled and the output relay adopts the state that you defined in the parameter **Behavior at end of locking**. The locking function always switches without a delay. During a lock, the most recent switching telegram is saved and delay times and staircase lighting times continue.

Lock at object value "1"; Behavior at start of locking = no reaction; Behavior at end of locking = Follows current value; relay operation: Normally opened

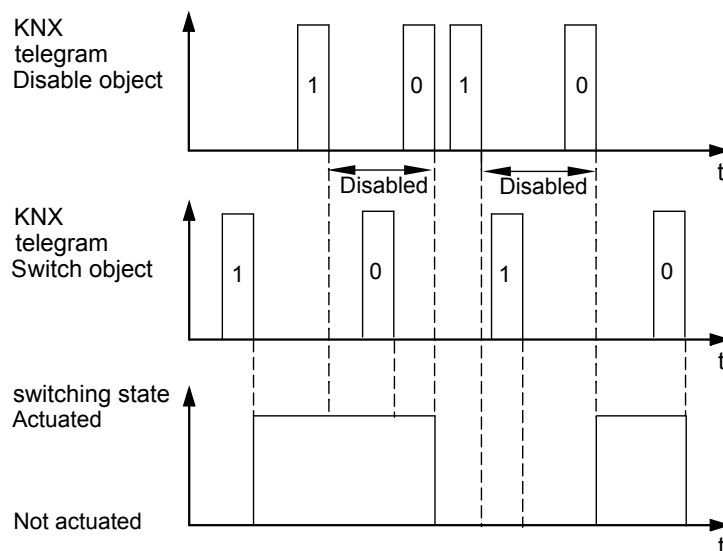

Lock Behavior after Download

After a download, the lock function is also set as in the case of bus voltage recovery. The parameter **Behavior after download** determines which state is set.

If the parameter **Behavior after download** is set to the value **As before download**, the locking function is activated as before and the relay is switched accordingly.

Lock Behavior after Bus Voltage Recovery

Disabled:

The locking function is not activated after a bus voltage recovery, regardless of the state it had before the bus voltage failure.

Enabled:

After a bus voltage recovery, the locking function becomes active and the output is switched to the state that you defined via the parameter **Behavior at start of locking**. If you have set the value **No reaction** here, the output is locked in its current state.

As before bus voltage failure:

The locking function is brought to the state that was active before the bus voltage failure. If the locking function was active, the output is controlled by its settings in the parameter **Behavior at start of locking**.

Group Objects of Locking Function

No.	Name	Object function	Length	Behavior	Data Type
57	Master Output 1 & (name of the channel)	Lock	1 bit	Received	1.003 Enable

Safety and Alarm Settings

Safety Function Switching

The global safety function is activated on the **Extended settings** tab with the parameter **Device safety** and the global settings are parameterized there.

The effect of the safety function can be parameterized here for each channel. You can enable the safety function individually for each switching channel.

 Master/Ext. 1/2 Output 1-8 -Switch: Switching – Safety and alarm settings 	Safety function	
	Safety function	Disabled Enabled
	Behavior at start of safety	No reaction Pressed Released Blinking (5s cycle)
	Behavior at end of safety	No reaction Pressed

		Released
		Follows current value
	(Cycle time surveillance for Safety object" > 0)	
		
	Behavior at exceeding cycle time	No reaction
		Pressed
		Released
		Blinking (5s cycle)

The safety function is activated if the **safety object** receives a telegram with the object value that you defined with the parameter **Device safety** (). The reaction is defined by the parameter **Behavior at start of safety**.

If the **safety object** receives a telegram with the object value opposite of that for activation, the safety function is canceled and the output relay adopts the state that you defined in the parameter **Behavior at end of safety**.

The device then waits for a telegram from an external sender within the globally set cycle time. If such a telegram is not received within the monitoring time, the parameter **Behavior at exceeding cycle time** is used to determine what is to happen.

Priority

The safety function is a 1-bit group object with the highest priority. This means that this object takes precedence over the following group objects:

Alarm object / Lock object / Priority object [Priority of Functions for Switching, page 32](#)

Logical input object

Scene object

Central switch object

Staircase fix / Staircase variable object

Switch object

Group Objects for Central Safety

No.	Name	Object function	Length	Behavior	Data Type
23	Central	Safety	1 bit	Received	1.005 Alarm

Alarm Function

In the case of an alarm, the alarm function can be used to set each output to a desired alarm state. The output is disabled for further operation. Only a higher-level function with a higher priority can still be used to switch the output to a different state. You can activate the alarm function individually for each output channel. The alarm function can be parameterized here for each channel.

	Master/Ext. 1/2 Output 1-8 -Switch: Switching	Alarm function
---	---	-----------------------

– Safety and alarm settings 	Alarm function	Disabled Enabled
	Alarm	At object value "1" At object value "0"
	Behavior at start of alarm	No reaction Pressed Released Blinking (5s cycle)
	Behavior at end of alarm	No reaction Pressed Released Follows current value
	Behavior after bus voltage recovery	Disabled Enabled As before bus voltage failure

Object Values for Alarm

The alarm function is activated if the **alarm object** receives a telegram with the object value that you defined with the parameter **Alarm**. The reaction is defined by the parameter **Behavior at start of alarm**.

If the **alarm object** receives a telegram with the object value opposite of that for activation, the alarm function is canceled and the output relay adopts the state that you defined in the parameter **Behavior at end of alarm**.

At object value "1":

The object value "1" switches on the alarm function. If the object value "0" is received, the alarm function is switched off again.

At object value "0":

The object value "0" switches on the alarm function. A telegram with the object value "1" deactivates the function again.

Behavior of the Alarm after Bus Voltage Recovery

Disabled:

The alarm function is not activated after a bus voltage recovery, regardless of the state it had before the bus voltage failure.

Enabled:

After a bus voltage recovery, the alarm function becomes active and the output is switched to the state that you defined via the parameter **Behavior at start of alarm**.

As before bus voltage failure:

The alarm function is brought to the state that was active before the bus voltage failure. If the alarm function was active, the output is controlled by its settings in the parameter **Behavior at start of alarm**.

Priority

The alarm function is a 1-bit group object with high priority. The device safety function has the highest priority. The priority order for switching can be defined

globally (Priority of Functions for Switching, page 32). The **alarm object** takes precedence over the following group objects:



- The priority relative to the **locking object / priority object** is defined centrally for switching: Priority of Functions for Switching, page 32
- **Logical input object**
- **Scene object**
- **Central switch object**
- **Staircase fix / Staircase variable object**
- **Switch object**

Group Objects of the Alarm Function

No.	Name	Object function	Length	Behavior	Data Type
58	Master Output 1 & (name of the channel)	Alarm	1 bit	Received	1.005 Alarm

Failure and Download Behavior

You can enable this function individually for each switching channel. The behavior of the switch output in the case of a bus voltage failure / bus voltage recovery and application download is defined.

 Master/Ext. 1/2 Output 1-8 -Switch: Switching – Safety and alarm settings 	Failure and download behavior	
	Failure and download behavior	Disabled Enabled
	Relay state after bus voltage failure	No reaction Pressed Released
	Relay state after bus voltage recovery	As before bus voltage failure Pressed Released
	Relay state at end of download	As before download Pressed Released

Relay Behavior after Bus Voltage Failure

If the bus voltage falls below 18 V, the relay can be switched to a parameterized state. The relay state can be defined as either **pressed** or **released** or remain in the state it had before the failure (**No reaction**). At the same time, the current switching position of the relay is saved in the device.

Possible settings:

No reaction:

The relay contact remains unchanged in its current position. If time functions (staircase lighting time function, on-delay, off-delay) are currently active, they are canceled.

Pressed:

In the case of a normally opened contact, the relay is closed; in the case of a normally closed contact, the relay is opened. Running time functions are deactivated.

Released:

In the case of a normally opened contact, the relay is opened; in the case of a normally closed contact, the relay is closed. Running time functions are deactivated.

Relay Behavior after Bus Voltage Recovery

In the case of bus voltage recovery, the relay can adopt a parameterized state.

Possible settings:

Pressed:

In the case of a normally opened contact, the relay is closed; in the case of a normally closed contact, the relay is opened.

Released:

In the case of a normally opened contact, the relay is opened; in the case of a normally closed contact, the relay is closed.

As before bus voltage failure:

With the parameter “As before bus voltage failure”, the relay adopts the state that was saved in the device at the time of the bus voltage failure. Any subsequent manual switchings are overwritten.

Priority

The reaction to the behavior set here for bus voltage recovery has a low priority. If a function with a higher priority is activated for the drive directly after bus voltage recovery, the settings described below apply to these functions.

Relay states caused by higher-priority functions (higher-level function) take precedence over behavior after bus voltage recovery.

Behavior after Download

After the ETS download, the relay can adopt a parameterized state.

If an internal defect or a faulty download results in a state in which the application is not operational, the device will not react. The output relays remain in their last position.

If you wish to activate the behavior after ETS download for an output channel, you must select a “**relay state at end of download**” for each channel.

Possible settings:

As before download:

The relays execute the behavior set before the download. Any subsequent manual switching is overwritten. If a higher-level function (logic operation, priority control or lock) is active, the behavior you defined for these functions will be executed.

Pressed:

In the case of a normally opened contact, the relay is closed; in the case of a normally closed contact, the relay is opened.

Released:

In the case of a normally opened contact, the relay is opened; in the case of a normally closed contact, the relay is closed.

Priority

Relay states caused by higher-priority functions take precedence over behavior after ETS download.

Example:

OR logic operation with parameterized value of the logic object after bus voltage recovery = 1, prevails and switches the output.

Express Settings for Blind/Roller Shutter

On the **Express settings for blind / roller shutter** tab, you can set basic settings and enable or disable other functions.

To control blinds/roller shutters, you can set the channel function of the device to the operating mode **Blind or roller shutter**. Now, two outputs will always be merged into a single blind / roller shutter channel. Please install the drives according to the installation instructions.

The operating mode is selected for each output on the Defining Channel Functions, page 21:

	General settings	Channel function for Master /	Blind
		Extension 1 / Extension 2	
	Master / Ext. 1/2	Output 1+2 / 3+4 / 5+6 / 7+8	
	Output 1+2 / 3+4 / 5+6 / 7+8	Express settings for blind	...
	Blind		
	General settings	Channel function for Master /	Roller shutter
		Extension 1 / Extension 2	
	Master / Ext. 1/2	Output 1+2 / 3+4 / 5+6 / 7+8	
	Output 1+2 / 3+4 / 5+6 / 7+8	Express settings for roller shutter	...
	Roller shutter		

Please install the drives according to the installation instructions. When connecting the motor, note the correct direction of rotation for movement up/down.

There are many different blind variants for indoor and outdoor use. The channel enables the control of a blind / roller shutter motor with max. 1000 VA. Only one motor may be connected per channel. The motor must have an end position switch.

NOTICE

CHECK BEFORE COMMISSIONING:

The load connections and the order of the devices (Master > Extension 1 > Extension 2) must correspond to your ETS programming.

- Connect blind motors to the blind channels specified in the ETS.
- Connect loads to the switching channels specified in the ETS.
- If the extension is planned as extension 1 (E1), connect it directly to the master.
- If the extension is planned as extension 2 (E2), then connect it to extension 1.

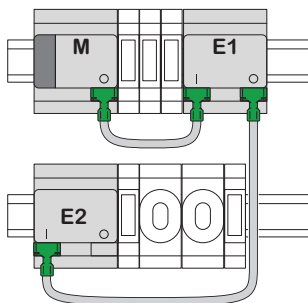

An extension cannot be put into operation if the order of the devices does not correspond to your programming in the ETS.

Blind/Roller Shutter Control

The **Express settings** can be used to move the connected drive manually to the desired position. Four group objects are available for this purpose: “**Movement in manual mode**” and “**Stop/step in manual mode**” (for roller shutters: “**Stop in manual mode**”). For positioning: “**Height position in manual mode**” and for blind only “**Slat position in manual mode**”.

- **Move drive:**
The object “**Movement in manual mode**” is responsible for moving the blind or roller shutter up and down. The drive moves down if the value “1” is received and up if the value is “0”.
- **Running time:**
Drive Running Time, page 72
The activated output remains active until the set running time has expired.
- **Pause on reverse for change of direction:**
Pause Time before Reverting (Pause on Reverse), page 74
If a control command in the opposite direction of motion is received while the drive is moving, the drive stops and waits for the defined pause on reverse time before starting to move in the new direction of motion.
- **Stop drive:**
A drive that is in motion is stopped on receiving a bus telegram for the object “**Stop/step in manual mode**” (for roller shutters: “**Stop in manual mode**”). The value received for the object is irrelevant here.
- **Slat tracking (for blind only):**
Slat Position after Movement, page 80
Once the drive has been stopped, the slats will be rotated to the desired position according to the settings for the parameter “**Slat position after movement**”.

- **Rotate blind slats (for blind only):**

In the case of blinds, the opening angle of the slats can be adjusted gradually using the object **“Stop/step in manual mode”**. For this, the drive must be at rest. If the group object receives the object value “1”, the slats are closed by one step; if the value “0” is received, they are opened.

If a step command is executed and the slats reach one of their movement range limits or are already in a limit position, the drive will briefly move in the desired direction. The duration of this motion also corresponds to the set step time. If the direction is changed from one step command to the next, the device will once again observe the pause on reverse as the wait time between the steps.

Manually moving to the height position and slat opening angle (blind) using absolute position commands

With this function, you can set a height position for blinds / roller shutters and the slat opening angle for blinds directly and manually using a percentage value. The desired percentage value always refers to the possible movement range 0-100% that you have set by defining the running times. You thus set an absolute height position for the entire movement range.

After receiving a new positional value, the device calculates a proportional travel time from the current position and the new desired position and moves the drive in the corresponding direction of motion for the duration of this travel time. The new position is buffered again. The accuracy of the position settings depends on the accuracy of your drive running time settings.

After a number of positioning movements, there are slight deviations between the actual position and the calculated position for physical and mechanical reasons. You can reset these deviations by means of reference movements (*Calibration*, page 98).

If a reference movement is required before a new positioning movement, the device initiates it before the movement to the new command position (*Calibration*, page 98).

The group objects **“Height position in manual mode”** and **“Slat position in manual mode”** (for blind only) are available for setting the absolute positional values.

- **Set height position:**

The object **Height position in manual mode** is responsible for the height position of the blind or roller shutter. Limit position 0% means that the blind / roller shutter is at the top. Limit position 100% means that the blind / roller shutter is at the bottom.

- **Rotate slats to opening position (for blind only):**

You can use the object **“Slat position in manual mode”** to set the slat opening angle directly. In slat position 0%, the slats are horizontally open, or closed at the top, while 100% means they are closed at the bottom. The actual opening angle of the slats depends on the type of blind used. *Setting the Blind Type (for Blind only)*, page 76.

When a new positional value is received, the channel calculates a running time needed to reach the new position from the current position. The drive is then moved to the new position for the calculated duration. The direction of motion is derived from the calculation.

If the device receives a new positional value during a positioning movement and the calculation results in the same direction of motion, the drive continues moving to the new command position.

- **Pause on reverse for change of direction:**

If a new positioning command is received during a drive motion or slat adjustment and the calculation results in the opposite direction of motion, the drive stops and waits for the defined pause on reverse time before starting the new positioning movement.

- **Slat tracking (for blind only):**

If the height position of the blind is changed and the blind reaches the desired position, the slat tracking function is executed and the slats are rotated to the desired position.

If, for example, you select the channel function **Blind / roller shutter** for output 1 +2 on the master, an ETS channel with the name **Master Output 1+2 - blind / roller shutter + name of the channel** is generated. All the group objects for this channel are located here.

Group Objects for Express Settings – Blind/Roller Shutter

No.	Name	Object function	Length	Behavior	Data Type
55	Master Output 1+2 name of the channel	Movement in manual mode	1 bit	Received	1.008 Up/Down
56	Master Output 1+2 name of the channel	Stop/step in manual mode (blind)	1 bit	Received	1.007 Step
56	Master Output 1+2 name of the channel	Stop in manual mode (roller shutter)	1 bit	Received	1.007 Step
57	Master Output 1+2 name of the channel	Height position in manual mode	1 byte	Received	5.001 Percent (0...100%)
58	Master Output 1+2 name of the channel	Slat position in manual mode (blind)	1 byte	Received	5.001 Percent (0...100%)
70	Master Output 1+2 name of the channel	Feedback for height	1 byte	Sending	5.001 Percent (0...100%)
71	Master Output 1+2 name of the channel	Feedback for slat (blind)	1 byte	Sending	5.001 Percent (0...100%)
75	Master Output 1+2 name of the channel	Feedback for moving	1 bit	Sending	1.010 Start/Stop
76	Master Output 1+2 name of the channel	Feedback for last direction	1 bit	Sending	1.008 Up/Down

Channel Name

You can assign a separate name for each channel, e.g. "Blind Kitchen". The name of the channel now appears on the parameters, channels and associated group objects.

	Master / Ext. 1/2	Express settings for blind/roller shutter
	Output 1+2 / 3+4 / 5 +6 / 7+8	
	Blind/roller shutter	
	Name of the channel	<i>Blind Kitchen</i>

Drive Running Time

The individual running times for the blind / roller shutter can be determined very well with a stopwatch.

If the running times to be set are too short to be measured with the stopwatch, first set an approximate value. Test the behavior of the drive or of the slats by means of positioning commands (for blind only). If the desired positions are not fully reached, correct the running times upwards. If the positions are overshoot, correct the running times downwards. Check your corrections with new positioning

commands. Perform multiple tests, as the small deviations only become visible or detectable after several motions.

In addition to the aforementioned deviations, environmental factors (temperature, rain, etc.) also cause deviations in the motion behavior of the drives. Since the drives cannot signal their current position and the current position is always calculated, the channel cannot detect these deviations. In order to be able to continue to position the drive accurately, it is helpful to return the drives to a fixed starting position by means of regular reference movements. In this way you can achieve satisfactory positional accuracy for a long time.

Further information can be found in the section *Calibration*, page 98.

The factory setting for the running time is 2 minutes, with up and down movement parameterized the same.



This duration is required for the drive to move from one end position (blind / roller shutter is fully open or fully closed) to the opposite end position. After the set running time, the relay of the corresponding channel is automatically switched off (even if the drive has not yet reached its end position with the values set here). If necessary, check whether the drive manufacturer has provided information about running times.

Same Running Times for Up and Down

 Master / Ext. 1/2 Output 1+2 / 3+4 / 5 +6 / 7+8 Blind/roller shutter	Express settings for blind/roller shutter	
	Blind control / roller shutter control	
	Use same time for up and down	Yes
	Up/Down time (5s...99:59.9 min)	02:00.0

Different Running Times for Up and Down

If the parameter **Use same time for up and down** is deactivated, different running times can be set for up and down. The **Running time: Up** should be parameterized slightly longer so that the end stops are always reached, even in the case of low temperatures or a heavy blind / roller shutter.

 Master / Ext. 1/2 Output 1+2 / 3+4 / 5 +6 / 7+8 Blind/roller shutter	Express settings for blind/roller shutter	
	Blind control / roller shutter control	
	Use same time for up and down	No
	 Up time (5s...99:59.9 min)	02:00.0
 Down time(5s...99:59.9 min)	02:00.0	

The **Running time: Up** should be parameterized slightly longer so that the end stops are always reached, even in the case of low temperatures or a heavy blind / roller shutter.

This type of running time allowance should be taken into account due to the physical fact that drives take longer for upward movements than for downward

movements due to the effect of gravity on the blind / roller shutter. Since this time deviation can be very short, you have to execute multiple movements to become aware of this behavior. It is useful to move the drive from 10% to 90% and back to 10% several times. If you notice that the drive does not completely reach the upper end position after these movements, you can increase the **“Running time: Up”**.

Pause Time before Reverting (Pause on Reverse)

 Master / Ext. 1/2 Output 1+2 / 3+4 / 5 +6 / 7+8 Blind/roller shutter	Express settings for blind/roller shutter	
	Blind control / roller shutter control	
	Pause time before reverting (2...255, unit = 100 ms)	5

If the channel for a drive that is currently in motion receives a motion command in the opposite direction, it first turns off both output relays for this channel.

Before turning on the relay for the new direction of motion, it waits for the set **Pause time before reverting**.

The channel observes the pause on reverse even if it is to rotate the slats in different directions when executing two step commands (for blind only).

NOTICE

THE DRIVE MAY BE DAMAGED.

The drive may be damaged if the pause times are too short. Be sure to refer to the specifications in the data sheet of the drive manufacturer when setting the values.

Slat Control (for Blind only)

Slat Rotation Time

The **Slat rotation time** is the time during which the slat performs a complete movement from 0% to 100% (or vice versa). The adjustment range for the opening angle is dependent on the type of blind used.

	Blind type: Downwards closed / upwards horizontal	Blind type: Downwards tilted / upwards horizontal	Blind type: Downwards closed / upwards closed	Blind type: Downwards tilted / upwards closed
Slat position 0 %	Horizontal open	Horizontal open	Top closed	Top closed
Slat position 100 %	Bottom closed	Bottom closed	Bottom closed	Bottom closed

	Master / Ext. 1/2	Express settings for blind/roller shutter
	Output 1+2 / 3+4 / 5 +6 / 7+8	
	Blind/roller shutter	<p>Slat control</p> <p>Slat rotation time (open/closed) (0.1 s...25 s) 01:00</p> <p>Steps that shall be executed during slat rotation (1...10) 10</p>

If the slat rotation time to be set is too short to be measured with the stopwatch, first set an approximate value. Test it by sending step telegrams.

Step commands can be used to rotate the blind slats. The opening angle of the slats can be changed in small steps, e.g. to prevent dazzle caused by a change in the position of the sun.

Depending on the **Slat rotation time** in one direction of motion, you can use the step time to provide the user with a certain number of steps for opening or closing the slats. The number of possible steps varies with the slat running time.

If the slat running time is 2.5 s, for example, you have a maximum of 15 steps available for moving through the entire slat opening range in one direction ($2.5 \text{ s} / 166 \text{ ms} = 15 \text{ steps}$).

If you only wish to provide the user with 5 slat steps in this case:

$$2.5 \text{ s} / 5 \text{ steps} = 0.5 \text{ s step time}$$

Procedure for measuring short slat running times:

- Set an approximate time and select a large number of steps. This results in the step time. Example:
Slat running time = 1 s
Number of steps = 10; => Step time = 100 ms.
- Move the slats to the closed position (slat position 100%). For blind types with operating position, this is the lower end position.
- Count step commands: now send step commands until the blind moves upwards, and count the steps required.
- Example: The blind requires 5 steps to move through the slat adjustment range. With the sixth step, the blind moves upwards.
- With the set values for the step time (default step time: 100 ms), the following slat running time is calculated: $100 \text{ ms} \times 5 \text{ steps} = 0.5 \text{ s}$.
- You can now enter this value as the slat running time.

Procedure for measuring long slat running times:

- Move the slats to the closed position (slat position 100%). For blind types with operating position, this is the lower end position.
- Send an "Up" motion command.
- Before opening the blind, the drive rotates the slats into the open position (0%). Measure the time for this rotation.
- Stop the drive after the rotation.
- For blind type: **Downwards tilted / upwards horizontal** and blind type: **Downwards tilted / upwards closed** (with operating position), note that the closed slat position is only set in the lower end position. You must then also add the time for the rotation from the operating position to the closed position.

NOTE: For blinds types 1 and 3 (without operating position), your setting for the slat running time affects the opening angle after a movement, since the selected opening angle (percentage value for the automatic slat position) is converted into a proportional rotation time for the slats. The same applies to the slat tracking function after a movement.

Setting the Blind Type (for Blind only)

If you wish to program the slat control for a blind, you should define your blind type before starting the parameterization.

The application distinguishes between four different types of blinds, which you can recognize by the position of their slats during the movement. Two of these types have a mechanically defined operating position. They can be recognized seen from the tilted slat position during a downward movement. The operating position limits the possible opening angle of the slats, unless the blind is in its lower end position.

This is done using the parameter **Movement of the existing blind**.

 Master / Ext. 1/2 Output 1+2 / 3+4 / 5 +6 / 7+8 Blind	Express settings for blind	
	Slat control	
	Movement of the existing blind	Downwards closed / upwards horizontal
		Downwards tilted / upwards horizontal
		Downwards closed / upwards closed
	Downwards tilted / upwards closed	

Blind Type: Downwards Closed/Upwards Horizontal

(Without operating position)

- Upward movement:
Slats in horizontal open position (slat position 0%)
- Downward movement:
Slats closed downwards (slat position 100%)
- Possible adjustment range for the opening angle of the slats:
0-100%

Downwards closed/upwards horizontal

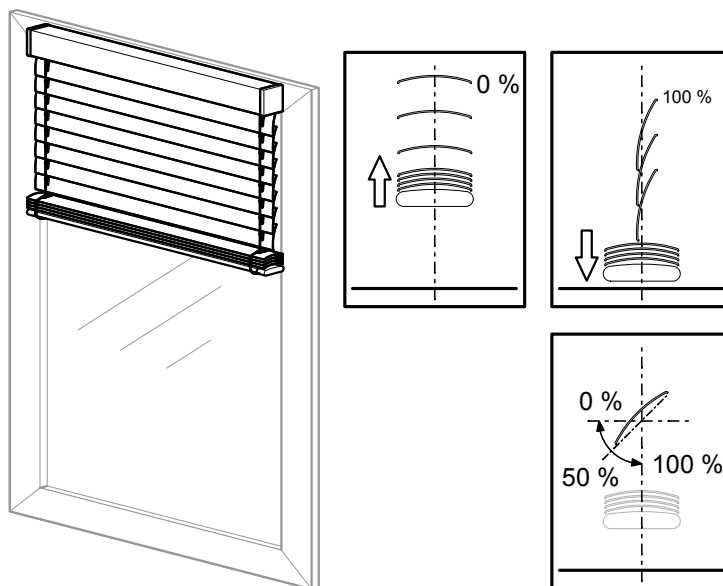

The parameter **Slat position after movement in %** allows you to define the behavior of the slats after a movement for the channel. If you set the parameter to **Operating position**, you can set an opening angle to be adopted by the slats after every downward movement.

Master / Ext. 1/2 Output 1+2 / 3+4 / 5 +6 / 7+8 Blind	Express settings for blind	
	Slat control	Downwards closed / upwards horizontal
	Movement of the existing blind	Last slat position
	Slat position after movement in %	No reaction Operating position
	↻ Operating position of slat in %	50

The preset value of 50% corresponds to a slat opening angle of about 45°. Since this position is set on a time-controlled basis, please refer also to the section Slat Rotation Time, page 74.

NOTE: Unless otherwise indicated in the following instructions, the examples refer to this type of blind.

Blind Type: Downwards Tilted/Upwards Horizontal

(With operating position)

- Upward movement:
Slats in horizontal open position (slat position 0%)
- Downward movement:
Slats tilted down in the operating position (slat position in operating position)
- Possible adjustment range for the opening angle of the slats:
0% to the operating position if blind not in lower end position
0-100% if blind in lower end position

Downwards tilted/Upwards horizontal

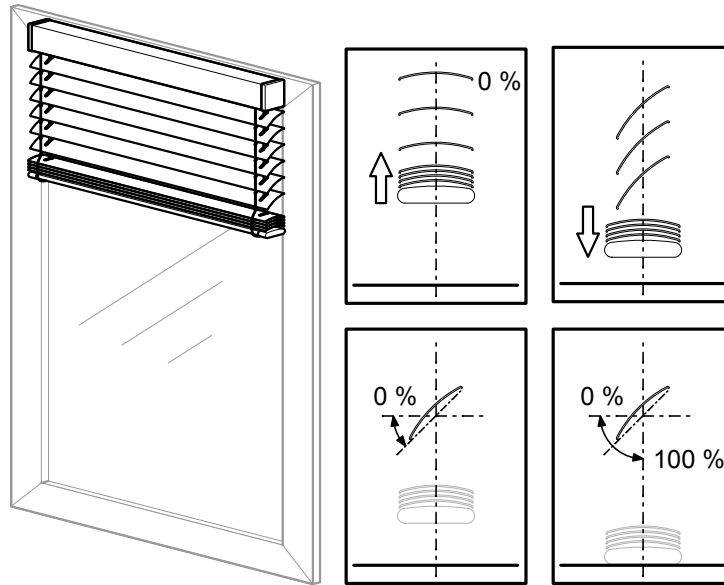

The parameter **Slat position after movement in %** allows you to define the behavior of the slats after a movement for the channel.

Master / Ext. 1/2 Output 1+2 / 3+4 / 5 +6 / 7+8 Blind	Express settings for blind	
	Slat control	
	Movement of the existing blind	Downwards tilted / upwards horizontal
	Slat position after movement in %	Last slat position
		No reaction
		Operating position
	Existing slat position during downwards movement in %	50

You can use the parameter **Existing slat position during downwards movement in %** to set the opening angle for the operating position.

Blind Type Downwards Closed/Upwards Closed

(Without operating position)

- Upward movement:
Slats closed upwards (slat position 0%)
- Downward movement:
Slats closed downwards (slat position 100%)
- Possible adjustment range for the opening angle of the slats:
0-100%

Downwards closed/Upwards closed

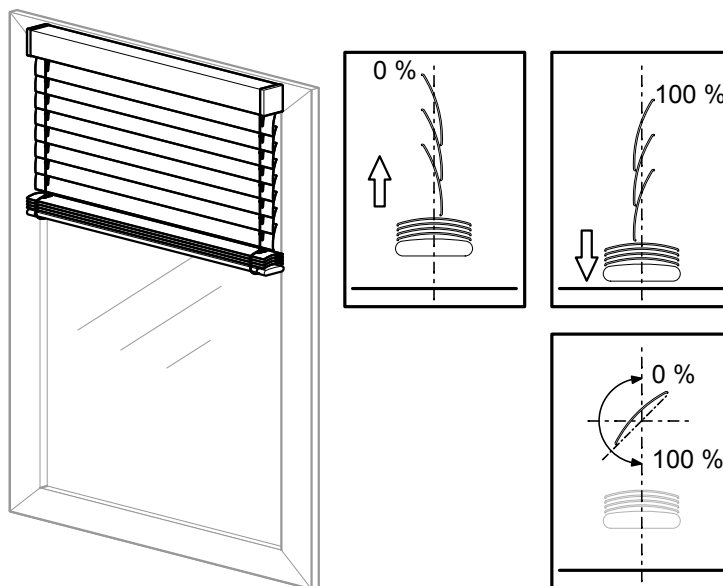

The parameter **Slat position after movement in %** allows you to define the behavior of the slats after a movement for the channel. If you set the parameter to **Operating position**, you can set an opening angle to be adopted by the slats after every downward movement.

Master / Ext. 1/2 Output 1+2 / 3+4 / 5 +6 / 7+8 Blind	Express settings for blind	
	Slat control	
	Movement of the existing blind	Downwards closed / upwards closed
	Slat position after movement in %	Last slat position No reaction Operating position
	Operating position of slat in %	75

The preset value of 75% corresponds to a slat opening angle of about 45°. Since this position is set on a time-controlled basis, please refer also to the section Slat Rotation Time, page 74.

Blind Type: Downwards Tilted/Upwards Closed

(With operating position)

- Upward movement:
Slats closed upwards (slat position 0%)
- Downward movement:
Slats tilted down in the operating position (slat position in operating position)
- The slats are closed on reaching the lower end position (slat position 100%)
- Possible adjustment range for the opening angle of the slats:
0% to the operating position if blind not in lower end position
0-100% if blind in lower end position

Downwards tilted/Upwards closed

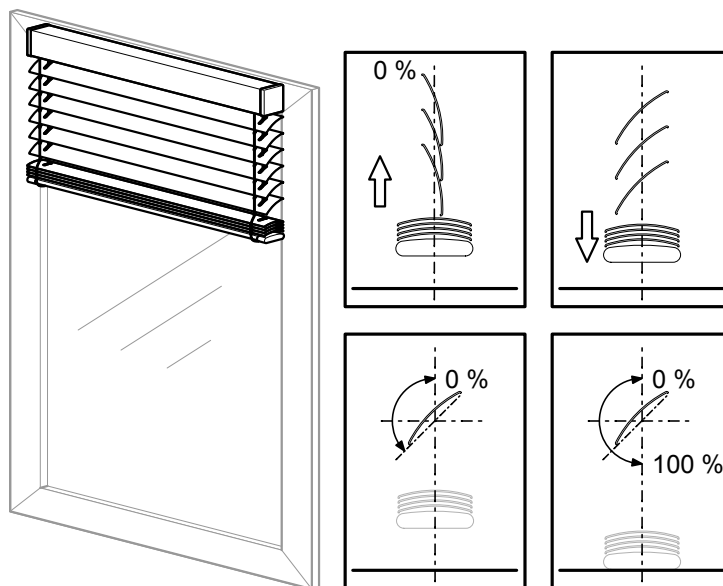

The parameter **Slat position after movement in %** allows you to define the behavior of the slats after a movement for the channel.

Master / Ext. 1/2 Output 1+2 / 3+4 / 5 +6 / 7+8 Blind	Express settings for blind	
	Slat control	
	Movement of the existing blind	Downwards tilted / upwards closed
	Slat position after movement in %	Last slat position No reaction Operating position
	Existing slat position during downwards movement in %	75

You can use the parameter **Existing slat position during downwards movement in %** to set the opening angle for the operating position.

Slat Position after Movement

With every blind movement, the position of the slats also changes, depending on the direction of motion. After the movement, the slats stay in this new position. With this application, however, you can automatically move or reset the slats to a desired position after a movement.

Using the parameter “**Slat position after movement**”, you can define the behavior of the slats after a movement for each blind channel.

The following parameters are available for this:

- **No reaction** (stay in the current position)
- **Operating position** (move to operating position)
- **Last slat position** (move to the slat opening angle that the blind had before the start of the movement)

The slat opening angle you have defined is set after each positioning movement of the blind or after a manual motion command terminated by a stop telegram.



After a bus voltage failure or a download, the last slat position is not clearly defined, so the last slat position is assumed to be the operating position.

Locking Manual Mode

You can control the connected drives via the group objects the for manual operating options or via automatic control. There are two options available for the manual operating options:

- Move manually to height position and slat opening angle (for blind only) via Up/Down/Step/Stop commands
- Move manually to height position and slat opening angle (for blind only) using absolute position commands

If you want to stop manual operation temporarily, you can enable lock of manual mode for each output channel:

 Master / Ext. 1/2 Output 1+2 / 3+4 / 5 +6 / 7+8 Blind/roller shutter	Express settings for blind/roller shutter	
	Locking manual mode	Disabled Enabled
		
	Manual locking	At object value "1" At object value "0"

Depending on the setting, manual operation is disabled or enabled when a new telegram value is received:

- **"Manual locking"** = "at object value "0"
If **"Manual locking"** = "0": manual operation disabled (manual locking active)
If **"Manual locking"** = "1": manual operation enabled (manual locking inactive)
- **"Manual locking"** = "at object value "1"
If **"Manual locking"** = "0": manual operation enabled (manual locking inactive)
If **"Manual locking"** = "1": manual operation disabled (manual locking active)

Group Objects for Lock of Manual Mode





No.	Name	Object function	Length	Behavior	Data Type
59	Master Output 1+2 name of the channel	Lock of manual mode	1 bit	Received	1.003 Enable

Scenes

If you want to change multiple room functions simultaneously at the press of a button or with a command, you can do so using the scene function. You can use a scene, for example, to switch on the room lighting, set the heating control to daytime operation and control the blinds.

Without the scene function, you would have to send a separate telegram to each actuator to get the same setting, since these functions can not only have different telegram formats, but also the telegram values have different meanings (e.g. value "0" for lighting OFF and for OPEN blind).

Enabling Scenes

	Master/Ext. 1/2 Output 1-8 -Switch: Blind/Roller shutter	Express settings for blind/roller shutter					
	-Scenes settings	<table border="0"> <tr> <td>Scenes</td> <td>Disabled</td> </tr> <tr> <td></td> <td>Enabled</td> </tr> <tr> <td>Scene settings</td> <td></td> </tr> </table>	Scenes	Disabled		Enabled	Scene settings
Scenes	Disabled						
	Enabled						
Scene settings							

Group Objects for Scene

No.	Name	Object function	Length	Behavior	Data Type
67	Master Output 1+2 name of the channel	Scene	1 byte	Receives	18.001 Scene control

Number of Scenes

	Master / Ext. 1/2 Output 1+2 / 3+4 / 5 +6 / 7+8 -Blind / roller shutter	Scene settings	
	Scenes settings	<table border="0"> <tr> <td>Required number of scenes</td> <td>1 (1 – 16)</td> </tr> </table>	Required number of scenes
Required number of scenes	1 (1 – 16)		

You can use the scene function to include multiple channels in a scene control. Up to 16 different scenes are available for each output channel.

Each of the 16 scenes can be disabled again.

	Master / Ext. 1/2 Output 1+2 / 3+4 / 5 +6 / 7+8 -Blind / roller shutter	Scene settings																		
	Scenes settings	<table border="0"> <tr> <td>Scene 1 (1-16)</td> <td>Disabled</td> </tr> <tr> <td></td> <td>Enabled</td> </tr> <tr> <td>Scene 1 Description</td> <td></td> </tr> <tr> <td>Scene 1 Address (0-63)</td> <td>Scene address 0 - 63</td> </tr> <tr> <td>Dependent: Global Settings for Scenes, page 27</td> <td></td> </tr> <tr> <td>Scene 1 Address (1-64)</td> <td>Scene address 1 - 64</td> </tr> <tr> <td>Dependent: Global Settings for Scenes, page 27</td> <td></td> </tr> <tr> <td>Scene 1 height in %</td> <td>0 (0-100)</td> </tr> <tr> <td>Scene 1 slat position in %</td> <td>0 (0-100)</td> </tr> </table>	Scene 1 (1-16)	Disabled		Enabled	Scene 1 Description		Scene 1 Address (0-63)	Scene address 0 - 63	Dependent: Global Settings for Scenes, page 27		Scene 1 Address (1-64)	Scene address 1 - 64	Dependent: Global Settings for Scenes, page 27		Scene 1 height in %	0 (0-100)	Scene 1 slat position in %	0 (0-100)
	Scene 1 (1-16)	Disabled																		
		Enabled																		
	Scene 1 Description																			
	Scene 1 Address (0-63)	Scene address 0 - 63																		
	Dependent: Global Settings for Scenes, page 27																			
	Scene 1 Address (1-64)	Scene address 1 - 64																		
Dependent: Global Settings for Scenes, page 27																				
Scene 1 height in %	0 (0-100)																			
Scene 1 slat position in %	0 (0-100)																			

For clarity, a short description can be stored for each scene.

Each of these scenes can be assigned one of 64 possible scene addresses 0 to 63 (corresponding to telegram values 0-63) or 1 to 64 (corresponding to telegram values 0-63). This depends on the global settings for scenes.

Global Settings for Scenes, page 27

You can store height positions and also, for blinds, slat opening angles as scene values. When the actuator receives a telegram calling a scene number, the drive is moved to the saved position and the slats are rotated. The scene positions you store during start-up can be overwritten later by the user if he wants to change them.

Time Delay for Scene Processing

To avoid high power-on currents when switching to a complex scene, you can parameterize a time delay for each output channel. (Especially in the case of many motors).

	Master / Ext. 1/2	Scene settings
	Output 1+2 / 3+4 / 5 +6 / 7+8	
	-Blind / roller shutter	
	Scenes settings	Time delay for scene processing 0 (0...255, unit = 100 ms)

Calling and Saving Scene Values

Scene values for the output relays are called using the object “**Scene**”. After receiving a scene telegram, the device evaluates the sent scene address and controls the channels to the saved scene values.

If a reference movement is required before the drive is moved to the scene position, the reference movement is executed first and the drive then moves to the requested scene position.

Calibration, page 98

If the “**scene object**” receives a scene telegram with learning bit “1”, then for all scenes assigned to the received scene address, the current height position and, in the case of blind drives, the current slat position are saved as the new scene value.

NOTE: Note: If a scene address within a channel is assigned to multiple scenes (incorrect parameterization), only the last scene found with this scene address is called or saved. You can avoid this by assigning different scene addresses within a channel.

Telegram format

Telegrams for the scene function have the data format: L X D D D D D D.

L = learning bit

X = not used

DDDDDD = called scene address

If the learning bit in a telegram has the value “0”, then the relay states saved for the scene address are called and set.

If the learning bit receives the value “1”, then the current output states are saved as new scene values for the received scene address.

Take the scene address (0-63) and add 128 to get the value for learning the scene.

Examples:

Telegram value	Binary	Hexadecimal	Scene address
0	0000 0000	00	Call scene address 0
1	0000 0001	01	Call scene address 1
29	0001 1101	1D	Call scene address 29
57	0011 1001	39	Call scene address 57
63	0011 1111	3F	Call scene address 63
128 (0+128)	1000 0000	80	Learning scene address 0
129 (1+128)	1000 0001	81	Learning scene address 1
157 (29+128)	1001 1101	9D	Learning scene address 29
185 (57+128)	1011 1001	B9	Learning scene address 57
191 (63+128)	1011 1111	BF	Learning scene address 63

Overwrite Scene Values during Download

 Master / Ext. 1/2 Output 1+2 / 3+4 / 5 +6 / 7+8 -Blind / roller shutter Scenes settings	Scene settings	
	Overwrite scene values of actuator during download	<input checked="" type="checkbox"/> Enabled <input type="checkbox"/> Disabled

If you have enabled the parameter “**Overwrite scene values in actuator during download**”, the scene values saved in the device will be overwritten with your preset values on downloading. If you do not want to overwrite the values in the device when downloading, you must disable the parameter. In this case, the parameterized scene values are only written to the device memory during the first download. If an application download is then carried out, the scene values in the device memory are retained.

Priority

The scene function has the same priority as the normal blind / roller shutter function with control over the 4 group objects:

“**Movement in manual mode**” and “**Stop/step in manual mode**” (for roller shutters: “**Stop in manual mode**”)

For positioning: “**Height position in manual mode**” and “**Slat position in manual mode**” (for blind only).

This should be taken into account with regard to the priority of the higher-level functions.

Central Function for Blind

Enable Central Function for Each Drive

The central function is enabled or disabled here for each drive.

 Master / Ext. 1/2 Output 1+2 / 3+4 / 5 +6 / 7+8 -Blind / roller shutter Scenes settings	Express settings for blind / roller shutter	
	Central function	Enabled
		Disabled

The global settings and explanations of the central function can be found in the chapter **General settings** (Enabling Central Functions, page 23).

Using the central function, you can simultaneously open or close multiple blind channels with a telegram via the object **Central – Move up/down blind**.

Group Objects of the Central Function

No.	Name	Object function	Length	Behavior	Data Type
2	Central	Move up/down roller shutter	1 bit	Received	1.008 Up/Down
3	Central	Move up/down blind	1 bit	Received	1.008 Up/Down

Status Response

 Master / Ext. 1/2 Output 1+2 / 3+4 / 5 +6 / 7+8 -Blind / roller shutter	Express settings for blind / roller shutter	
	Status of height	Enabled
		Disabled
	Status of slat (for blind only)	Enabled
		Disabled
	Status of moving	Enabled
	Disabled	

Each blind channel can provide different status responses, depending on how it is enabled. The status response group objects are available and can be disabled.

Group Objects of Status Response for Blind/Roller shutter

No.	Name	Object function	Length	Behavior	Data Type
70	Master Output 1+2 name of the channel	Feedback for height	1 byte	Sending	5.001 Percent (0...100%)
71	Master Output 1+2 name of the channel	Feedback for slat (blind)	1 byte	Sending	5.001 Percent (0...100%)
75	Master Output 1+2 name of the channel	Feedback for moving	1 bit	Sending	1.010 Start/Stop
76	Master Output 1+2 name of the channel	Feedback for last direction	1 bit	Sending	1.008 Up/DOWN

Status of Height

The current position of the drive is provided as a value between 0-100%. The corresponding status object **“Feedback for height”** sends the value on the bus if the drive has reached a fixed position after a movement.

Status of Slats (for Blind only)

The current angle of rotation of the blind slats is provided as a value between 0-100%.

The corresponding status object **“Feedback for slat”** sends the value on the bus if the drive/slat has reached a fixed position after a movement.

Status of Moving

The status object **“Feedback for moving”** sends the movement status of the drive. This information is sent directly.

- **Sends a “1” when the movement/drive is started**
- **Sends a “0” when the movement/drive is stopped**

The status object **“Feedback for last direction”** sends the value for the last direction of movement of the drive.

- **Sends a “1” if the drive has been moved down or the slat has been closed by one step**
- **Sends a “0” if the drive has been moved up or the slat has been opened by one step**

Automatic Status

Once the function **“Status of automatic locking”** has been enabled, a new group object is available for the channel.

Group Objects of Status Response of Automatic Mode

No.	Name	Object function	Length	Behavior	Data Type
72	Master Output 1+2 name of the channel	Feedback for automatic mode	1 bit	Sending	1.003 Enable

The feedback object sends a "1" if automatic locking is active.

The feedback object sends a "0" if automatic locking is inactive.

Activating Extended Settings for Blind/Roller Shutter



 Master / Ext. 1/2 Output 1+2 / 3+4 / 5 +6 / 7+8 -Blind/roller shutter	Express settings for blind/roller shutter	
	Extended settings for blind/roller shutter	No Yes

To activate the extended settings for blind/roller shutter, you must enable them here.

Extended Settings for Blind/Roller Shutter

On the **Extended settings for blind/roller shutter** tab, you can defined additional settings and enable or disable additional functions.

On the **Express settings for blind/roller shutter** tab, activate the **Extended settings for blind/roller shutter**.

 Master / Ext. 1/2 Output 1+2 / 3+4 / 5 +6 / 7+8 -Blind/roller shutter	Express settings for blind/roller shutter	
 -Extended drive timing	Extended settings for blind/roller shutter	<input type="checkbox"/> No <input checked="" type="checkbox"/> Yes
	Idle time until upward movement	
-Automatic, Locking & Calibration settings	Startup delay	
	Additional startup time	
	Priority function	
	Logic function	
-Safety and alarm settings	Safety function	
	Alarm function	
	Failure and download behavior	

Extended Drive Timing

For special drives and blinds, you can adjust the drive times by means of additional parameters.

 Master / Ext. 1/2 Output 1+2 / 3+4 / 5 +6 / 7+8 -Blind/roller shutter	Extended drive timing	
-Extended drive timing	Idle time until upward movement (0...255, unit = 10 ms)	0
	Startup delay (0...255, unit = 10 ms)	0
	Deceleration delay (0...255, unit = 10 ms)	0
	Additional startup time when opening slat downwards (0...255, unit = 10 ms)	0
	Additional startup time when opening slat upwards (0...255, unit = 10 ms)	0

Idle Time until Upward Movement

If the blind used has an idle time in the closed lower position between pulling on the main strap and the first upward movement, you can compensate for this delay in this way.

The idle time can also be used when using a roller shutter to compensate for the roller shutter opening.

Example:

A value = 10 gives an idle time of 10 x 10 ms = 100 ms

	Master / Ext. 1/2	Extended drive timing	
	Output 1+2 / 3+4 / 5 +6 / 7+8		
	-Blind/roller shutter		
	-Extended drive timing	Idle time until upward movement (0...255, unit = 10 ms)	0

Startup Delay

Some motors do not bring full power directly when switched on, but only after a few milliseconds. You can use the time setting for the start-up delay to compensate for this.

A value = 10 gives a start-up delay of 2 x 10 ms = 20 ms

	Master / Ext. 1/2	Extended drive timing	
	Output 1+2 / 3+4 / 5 +6 / 7+8		
	-Blind/roller shutter		
	-Extended drive timing	Startup delay (0...255, unit = 10 ms)	0

Deceleration Delay

There are some motors that continue running for several milliseconds after they are switched off. This can also be caused by large and heavy blinds/roller shutters. If you notice this behavior, you can compensate for it using the setting for the deceleration delay.

A value = 6 gives a deceleration delay of 6 x 10 ms = 60 ms.

In this way, the motor will be switched off 60 ms earlier.

	Master / Ext. 1/2	Extended drive timing	
	Output 1+2 / 3+4 / 5 +6 / 7+8		
	-Blind/roller shutter		
	-Extended drive timing	Deceleration delay (0...255, unit = 10 ms)	0

Additional Start-up Time on Opening the Slat (for Blind only)

Some types of blinds require an additional start-up supplement before the first reaction of the slats when opening the slats due to the tensioning and releasing of the slat straps. This depends on the current slat position. The following parameters can be used to set a start-up supplement for the upper and lower slat positions.

 Master / Ext. 1/2 Output 1+2 / 3+4 / 5 +6 / 7+8 -Blind/roller shutter -Extended drive timing	Extended drive timing	
	Additional startup time when opening slat downwards (0...255, unit = 10 ms)	0
	Additional startup time when opening slat upwards (0...255, unit = 10 ms)	0

With these parameters for **Additional startup time when opening slat downwards**, set the start-up delay for an upward movement until the slat is rotated when the slats are in the open position (0%) (the previous blind movement was an upward motion).

Additional startup time when opening slat upwards: the start-up delay until the slat is rotated, which you define here, is always taken into account when opening the blind if the slat is in the closed position (100%) (the previous blind movement was a downward movement).

Automatic, Locking and Calibration Settings

Automatic Mode

In addition to manual control of the blind / roller shutter drives (via the group objects for the manual operating options), the software application also provides you with another set of group objects for automatic control.

Automatic control can be performed by other bus devices, e.g. presence detectors or light controllers, or via a building control system. Once you have activated automatic control for a channel, you can initially position the connected drive with equal priority using manual control or automatic control. The drive reacts identically on receiving control telegrams from one of the two types of control.

 Master / Ext. 1/2 Output 1+2 / 3+4 / 5 +6 / 7+8 -Blind/roller shutter -Automatic, Locking & Calibration settings	Automatic, Locking & Calibration settings	
	Automatic mode	
	Automatic mode	Disabled Enabled

In order to use the **automatic mode**, you must first activate the function in the ETS. Once **automatic mode** has been enabled, new group objects are available for the channel.

Group Objects of Automatic Mode for Blind/Roller Shutter

No.	Name	Object function	Length	Behavior	Data Type
60	Master Output 1+2 name of the channel	Movement in automatic mode	1 bit	Received	1.008 Up/Down
61	Master Output 1+2 name of the channel	Stop/step in automatic mode (blind)	1 bit	Received	1.007 Step



No.	Name	Object function	Length	Behavior	Data Type
61	Master Output 1+2 name of the channel	Stop in automatic mode (roller shutter)	1 bit	Received	1.007 Step
62	Master Output 1+2 name of the channel	Height position in automatic mode	1 byte	Received	5.001 Percent (0...100%)
63	Master Output 1+2 name of the channel	Slat position in automatic mode (blind)	1 byte	Received	5.001 Percent (0...100%)

The group objects for manual operation and automatic mode have equal priority. The drive always executes the command it received last on one of the objects.

Using parameter settings and objects, you can modify the operation of the two control options. You also have the possibility of defining the reciprocal influence of manual control and automatic control.

Lock of Automatic Mode

If operation with equal priorities for manual operation and **automatic mode** is not always suitable for your application, you can disable and re-enable **automatic mode** using an additional object as required:

 Master / Ext. 1/2 Output 1+2 / 3+4 / 5 +6 / 7+8 -Blind/roller shutter -Automatic, Locking & Calibration settings	Automatic, Locking & Calibration settings	
	Automatic mode	
	Lock of automatic mode	Disabled Enabled
	 Automatic locking	At object value "1" At object value "0"
	Status of automatic locking	Disabled Enabled
	Behavior on deactivating automatic locking via object	No reaction Accept current automatic position

Once the function “**Lock of automatic mode**” and “**Status of automatic locking**” has been enabled, new group objects are available for the channel.

- The feedback object sends a “1” if automatic locking is active.
- The feedback object sends a “0” if automatic locking is inactive.

Group Objects of Automatic Mode Lock

No.	Name	Object function	Length	Behavior	Data Type
64	Master Output 1+2 name of the channel	Lock of automatic mode	1 bit	Received	1.003 Enable
72	Master Output 1+2 name of the channel	Feedback for automatic mode	1 bit	Sending	1.003 Enable

Depending on the setting, the **automatic locking** is activated or deactivated when a new telegram value is received:

- “**Automatic locking**” = “**at object value 0**”
 If “**Automatic locking**” = “0”: **automatic locking** is active.
 If “**Automatic locking**” = “1”: **automatic locking** is inactive.



- “Automatic locking” = “at object value 1”
 If “Automatic locking” = “0”: automatic locking is inactive.
 If “Automatic locking” = “1”: automatic locking is active.

In addition, you can set the behavior of the drive to the end of **automatic locking**.

Furthermore, you can separately define the response of automatic control on receiving a manual control telegram.

Defining Dependency between Automatic Function and Manual Control

You can use the following parameter to define the reaction of the automatic function on receiving a control telegram from the manual operating options (**Movement in manual mode**, **Stop/step in manual mode**, **Height position in manual mode**, **Slat position in manual mode**, and calling up scenes):

 Master / Ext. 1/2 Output 1+2 / 3+4 / 5 +6 / 7+8 -Blind/roller shutter -Automatic, Locking & Calibration settings	Automatic, Locking & Calibration settings	
	Automatic mode	
	Reaction in automatic mode on receipt of a manual object value	Automatic mode remains enabled Automatic mode temporarily disabled
	 Deactivation time for automatic mode	1 min (1 min - 24 h)

Permanent deactivation of the automatic function can only be canceled by a telegram terminating automatic locking via the automatic locking object. The action you set in the parameter "Behavior on deactivating automatic locking via object" will be executed.

Once a temporary deactivation has elapsed, the drive remains in its current position until the next control telegram.

Locking Function

Using the **locking function**, you can move a blind / roller shutter to a desired locking position. The state of the output channel cannot be changed by other control commands as long as the lock is active. Only a higher-level function with a higher priority can still be used to move the drive to a different position.

You can enable the locking function individually for each output channel.

 Master / Ext. 1/2 Output 1+2 / 3+4 / 5 +6 / 7+8 -Blind/roller shutter -Automatic, Locking & Calibration settings 	Locking function	
	Locking function	Disabled Enabled
	Lock	At object value "1" At object value "0"
	Status of locking signal	Disabled Enabled
	Behavior at start of locking	No reaction

	Stop
	Up
	Down
	Move to position
Height position at start of locking in %	0 (0 – 100)
Slat position at start of locking in %	0 (0 – 100)
Behavior at end of locking	No reaction
	Up
	Down
	Move to position prior locking
	Accept current automatic position
Behavior after download	Disabled
	Enabled
	As before download
Behavior after bus voltage recovery	Disabled
	Enabled
	As before bus voltage failure

Once the “**Locking function**” and “**Status of locking signal**” have been enabled, new group objects are available for the channel.

You can activate and deactivate a channel lock using the **locking object**.

Group Objects of Locking Function

No.	Name	Object function	Length	Behavior	Data Type
65	Master Output 1+2 name of the channel	Lock	1 bit	Received	1.003 Enable
73	Master Output 1+2 name of the channel	Feedback for drive locking	1 bit	Sending	1.003 Enable

If the locking object receives a telegram with the object value that you set for the parameter Lock, all other functions for the channel are disabled. You can define the reaction using the parameter **Behavior at start of locking**.

If the locking object receives a telegram with the object value opposite of that for activation, the lock is canceled and the drive adopts the state that you defined in the parameter **Behavior at end of locking**.

The **Feedback for drive locking object sends** a “1” if the lock is active.

The **Feedback for drive locking** object sends a “0” if the lock is inactive.

Behavior of the Drive at Start of Locking

Set how the drive is to behave when the locking function becomes active:

- **No reaction:** Finish the actual task.
- **Stop:** The drive stops immediately (remains in its current position).
- **Up:** The drive moves to the upper end position.
- **Down:** The drive moves to the lower end position.
- **Move to position:** The drive moves to the defined position for height and slat (for blind only).

**Behavior at start of locking = move to position;
height position at start of locking = 40%; slat position at start of locking = 50%**

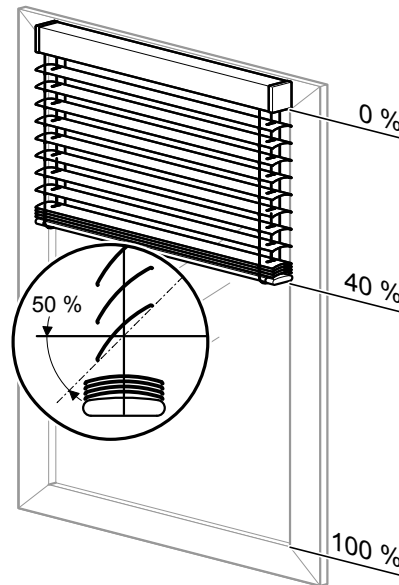

Once the drive has performed the desired action, it remains in this position and cannot be operated while the locking function is active. Only when a function with a higher priority becomes active will the reaction defined there be executed.

Behavior at the End of Locking

If the locking function has been switched off again by a new object value, you can operate the drive normally again. If the drive is to perform an automatic action after the locking function has been terminated, you can define it with this parameter:

- **No reaction:** the drive remains in its current position.
- **Up:** the drive moves to the upper end position.
- **Down:** the drive moves to the lower end position.
- **Move to position prior locking:** the drive returns to the position it had before the locking.
- **Accept current automatic position:** this setting is only useful if the automatic function is active. The drive moves to the last automatic position requested.

Lock Behavior after Download

After a download, the lock function is also set as in the case of bus voltage recovery. The parameter "**Behavior after download**" determines which state is set.

If the "**Behavior after download**" parameter is set to "**As before download**", the locking function is activated as previously set and the relay is switched accordingly.

Lock Behavior after Bus Voltage Recovery

Disabled:

The locking function is not activated after a bus voltage recovery, regardless of the state it had before the bus voltage failure.

Enabled:

After a bus voltage recovery, the locking function becomes active and the output is switched to the state that you defined via the parameter **Behavior at start of locking**. If you have set the value **No reaction** here, the output is locked in its current state.

As before bus voltage failure:

The locking function is brought to the state that was active before the bus voltage failure. If the locking function was active, the output is controlled by its settings in the parameter **Behavior at start of locking**.

Movement Range Limits

For certain applications, e.g. in the case of open tilting windows or window boxes for flowers in the summer, it may be helpful or necessary to limit the possible movement range of a drive temporarily or permanently.

NOTICE	
BLINDS/ROLLER SHUTTERS CAN BE DAMAGED.	
<ul style="list-style-type: none"> • The blinds/roller shutters may move outside the movement range limits and into any open windows. For this reason, consider where the reference movement is to be made (Calibration, page 98). • After a download or bus voltage recovery, a reference movement is made after initialization, even if the General reference movement function is disabled. The blinds/roller shutters may move outside the movement range limits and into any open windows. (Calibration, page 98). • After a download or bus voltage recovery, the movement range limitation may be disabled because no activation telegram has been received. • For this reason, consider where the reference movement is to be made: The reference movement after initialization is generally carried out towards the upper end position. A reference movement to the lower end position is only carried out if the parameter Reference position is set to lower. • Functions with a higher priority, such as safety function or alarm function, can also control blinds/roller shutters outside the movement range limitation. 	

If movement range limitation is active, manual operation, automatic functions or scene calls can only move the drive within the defined limit. The limitation also applies to motion commands from functions a lower priority. Only a higher-level function with a higher priority can still be used to move the drive to a different position outside the limit. This must be taken into account if the movement range is to be limited due to an obstacle. Obstacles in operation must be avoided.

You can activate the limits of the movement range individually for each output channel (enabled).

 Master / Ext. 1/2 Output 1+2 / 3+4 / 5 +6 / 7+8 -Blind/roller shutter -Automatic, Locking & Calibration settings	Movement range limits	
	Movement range limits	Disabled Enabled

	Limit movement range	Immediately after bus voltage recovery At object value "1" At object value "0"
	Feedback for range limitation	Disabled Enabled

After the function “**Movement range limits**” has been enabled, the parameter “**Limit movement range**” appears. Here you can define when and how the function is activated for the channel.

- **Immediately after bus voltage recovery**: the function becomes active immediately after bus voltage recovery or after a download. The drive can only move between the limits. Only a function with a higher priority can move the drive to a position outside the limit.
- **At object value “1”**: the object value “1” activates the limit. If the object value “0” is received, the entire movement range is enabled again.
- **At object value “0”**: the object value “0” activates the limit.

A telegram with the object value “1” deactivates the limit. In the case of activation by an object value, an additional group object “**Activate movement range limits**”, which can be used to switch the limit on and off, appears for this channel.

You can set the limits of the movement range using other parameters:

✕ Master / Ext. 1/2 Output 1+2 / 3+4 / 5 +6 / 7+8 -Blind/roller shutter -Automatic, Locking & Calibration settings	Movement range limits	
	Limit movement position	Limit range at upper position Limit range at lower position

If limitation is active, the drive will only move between the limits. The limitation applies to all motion commands from manual operation, automatic functions, scenes, and motion commands from functions with a lower priority. It is possible to limit either the upper position or the lower position.

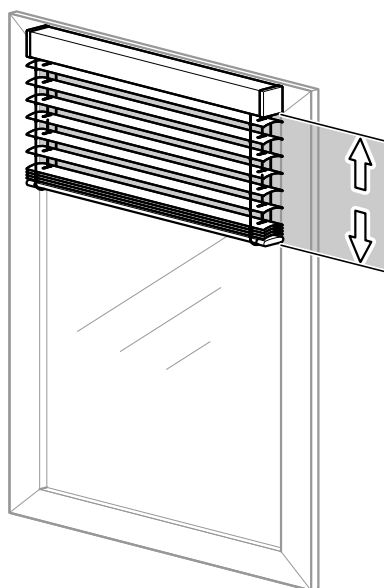

Limit range at lower position with upper limit = 0% (fix) and lower limit = 25%



If limitation is active, the drive will only move between the limits.

If the drive is outside the limits when movement range limitation is activated, it is automatically moved to the nearest limit and stops there.

If a drive reaches its movement range limits, this can be signaled to the bus via a status feedback object. Functions that depend on it, e.g. opening a window, can now be executed.

Master / Ext. 1/2 Output 1+2 / 3+4 / 5 +6 / 7+8 -Blind/roller shutter -Automatic, Locking & Calibration settings	Movement range limits	
	Limit movement position	Limit range at lower position
		
	Upper limit value in % (fix)	0
	Lower limit value in %	100 (0-100)
	Limit movement position	Limit range at upper position
		
	Upper limit value in %	100 (0-100)
	Lower limit in % (fix)	0

The **movement range limitation** function is often selected in summer when solar radiation is strong, so that it does not heat up rooms or dazzle people. The drive can no longer be moved manually all the way up, but in the event of a storm the weather alarm will move the blind to the safe position.

Group Objects of the Move Range Limits Function

No.	Name	Object function	Length	Behavior	Data Type
68	Master Output 1+2 name of the channel	Activate movement range limits	1 bit	Received	1.003 Enable
74	Master Output 1+2 name of the channel	Feedback for range limitation	1 bit	Sending	1.003 Enable

In addition, a **status feedback object** can be enabled that sends the status of the movement range limits function to the bus.

The value of the **status feedback object** receives the object value "1" as soon as the movement range limitation becomes active and the drive reaches the specified limit.

- If the drive is already within the specified limit when the movement range limitation is activated, the **status feedback object** immediately sends the object value "1".
- If the movement range is left or the limit is canceled due to a function with a higher priority, the object value changes to "0".

Drive Behavior after the End of Movement Restriction

If the limitation of the movement range is determined by object values and a new object value cancels an active limitation, then you can operate the drive normally again. If the drive is to perform an automatic action in this case, you can define it with the following parameter:

 Master / Ext. 1/2 Output 1+2 / 3+4 / 5 +6 / 7+8 -Blind/roller shutter -Automatic, Locking & Calibration settings	Movement range limits	
	Behavior at the end of movement restriction	No reaction Up Down Move to position prior to movement restriction Accept current automatic position

Values to be set:

- **No reaction:** the drive remains in its current position.
- **Up:** the drive moves to the upper end position.
- **Down:** the drive moves to the lower end position.
- **Move to position prior to movement restriction:** the drive returns to the position it had before the movement restriction.
- **Accept current automatic position:** this setting is only useful if the automatic function is active. The drive moves to the last automatic position requested.

Calibration

The calibrating function is activated centrally on the **Global settings for roller shutter and blind** tab with the parameter **Calibration**. If the function has been activated globally, the following group object is available for all channels and each channel can use the calibrating function: .

The device calculates the current position of a drive from the running times you have set for the drive and from the control commands it executes. This calculation must be performed because there is no feedback from the drive regarding its position. Even if you have set the running times very precisely, the internally calculated height position will deviate slightly from the actual height position after a number of movements. This is due to mechanical tolerances and weather conditions (temperature fluctuations, frost, rain, etc.).

The blind channel can reset these deviations by means of reference runs. For this purpose, it moves the drives to the upper or lower end position. After the reference run, the internal position calculation starts again from a fixed value. Any deviations that have arisen in the meantime are thus eliminated.

NOTE: The calibration function is especially important if you work a lot with position commands and high positioning accuracy is required. If the blind is controlled exclusively using the basic functions and position commands do not matter, then you do not need this function.

Group Object for Calibration

No.	Name	Object function	Length	Behavior	Data Type
17	Central	Calibration	1 bit	Received	1.010 Start/Stop

The channel-specific settings for the calibrating function can be found in Calibration, page 98.

Operating Principle

A reference movement can be triggered by a telegram on the central calibration object or after a certain number of movements. After a reference movement has been triggered, the drive moves to the desired reference position (end position). If you have set both end positions as reference positions, the drive will move to the nearest end position, depending on its current position.

In order to ensure that the drive reliably reaches the desired end position, the actuator adds a running time allowance of 5% of the total running time to the calculated travel time for each reference movement.

NOTE: If a weather alarm or other higher-level function is activated during a calibrating function, the calibrating function is canceled and the higher-level function is executed.

Per channel:

 Master / Ext. 1/2 Output 1+2 / 3+4 / 5 +6 / 7+8 -Blind/roller shutter -Automatic, Locking & Calibration settings	Calibration	
	Calibration	Disabled Enabled

Trigger of Calibration

 Master / Ext. 1/2 Output 1+2 / 3+4 / 5 +6 / 7+8 -Blind/roller shutter -Automatic, Locking & Calibration settings	Calibration	
	Trigger of calibration	Number of movements Value "1" on calibration object No. of movements or calibration object
	Delay of calibration via object (0...255, unit = 1 s)	0
	Number of movements until calibration	7 (1-20)

Triggering a reference movement after a number of movements

The channel adds up the total number of movements, irrespective of the control command that triggered the movements. Once the defined number of movements has been reached, the drive first performs a reference movement before the next positioning command. It then moves to the requested position. After the reference movement, the movement counter is reset.

Trigger reference movement via group object

If the object "" receives the value "1", a reference movement is started for all assigned channels. In order not to overload the power supply of the blind system, you can select a "" for each channel. If a new value "1" is received on the object during this delay time, the delay time is restarted. The object value "0" has no meaning.

Trigger reference movement after a number of movements or via group object

It is also possible to select a logic operation from the number of movements or the calibration telegram.

Reference Position

After a reference movement has been triggered, the drive moves to the desired parameterizable **reference position** (end position). If you have set both end positions as **reference positions**, the drive will move to the nearest end position, depending on its current position.

 Master / Ext. 1/2 Output 1+2 / 3+4 / 5 +6 / 7+8 -Blind/roller shutter -Automatic, Locking & Calibration settings	Calibration	
	Reference position	Upper Lower Upper and lower

Automatic Calibration

Each time the drive moves to the defined end position due to a positioning command, the calibrating function is performed. This means that a running time allowance of 5% of the total running time is added to the calculated travel time required by the drive to ensure that the drive reliably reaches the desired end position. Once the end position has been reached, the movement counter is also reset.

 Master / Ext. 1/2 Output 1+2 / 3+4 / 5 +6 / 7+8 -Blind/roller shutter -Automatic, Locking & Calibration settings	Calibration	
	Automatic calibration	Upper Lower Upper and lower

Position after Calibration via Object

The height position after the reference movement can be defined using the parameter "**Position after calibration via object**". If a movement is to be made to a "**new position**", set the height and, in the case of blinds, also the opening angle of the slats, in the movement range from 0% to 100%.

If the channel receives an absolute positioning command during the reference movement, it sets the desired position after the reference movement. In this case, the settings in the parameter "**Position after reference movement via object**" have no effect. All other control commands interrupt the calibrating function. The drive reacts to the received control commands.

 Master / Ext. 1/2 Output 1+2 / 3+4 / 5 +6 / 7+8 -Blind/roller shutter -Automatic, Locking & Calibration settings	Calibration	
	Position after calibration via object	Position prior reference movement Remain in reference position New position

Height position after calibration in %	0 (0-100)
Slat position after calibration in %	0 (0-100)

Reference Movement after Initialization

The reference movement after a download or bus voltage recovery serves to obtain an exact starting position for further positioning movements.

NOTE: The reference movement after initialization is always carried out, even if the function “**General reference movement**” is disabled.

The reference movement is triggered by an absolute positioning command. These include, for example, receiving a value on the objects “**Height position in manual mode**” or “**Height position in automatic mode**”, the calling of scenes, or movement to an absolute position in the case of weather alarm, alarm or lock. If, after initialization, the object “**Move object in manual mode**” receives a value that moves the blind / roller shutter to the upper end position, the actuator automatically evaluates this movement as a reference movement.

The reference movement after initialization is generally carried out towards the upper end position. If you have enabled sending of the status messages “**Feedback for height**” and/or “**Feedback for slat**”, this automatically sends the current status.

Reference Movement with Movement Range Limitation

NOTICE
<p>BLINDS/ROLLER SHUTTERS CAN BE DAMAGED.</p> <ul style="list-style-type: none"> • The blinds/roller shutters may move outside the movement range limits and into any open windows. For this reason, consider where the reference movement is to be made (Calibration, page 98). • After a download or bus voltage recovery, a reference movement is made after initialization, even if the General reference movement function is disabled. The blinds/roller shutters may move outside the movement range limits and into any open windows. (Calibration, page 98). • After a download or bus voltage recovery, the movement range limitation may be disabled because no activation telegram has been received. • For this reason, consider where the reference movement is to be made: The reference movement after initialization is generally carried out towards the upper end position. A reference movement to the lower end position is only carried out if the parameter Reference position is set to lower. • Functions with a higher priority, such as safety function or alarm function, can also control blinds/roller shutters outside the movement range limitation.





Movement Range Limits, page 95

Safety and Alarm Settings

Safety Function for Blind

The global **safety function** is activated on the **Extended settings** tab with the parameter **Device safety** and the global settings are parameterized there.

The effect of the **safety function** can be parameterized here for each channel. You can enable the **safety function** individually for each drive.

 Master / Ext. 1/2 Output 1+2 / 3+4 / 5 +6 / 7+8 -Blind/roller shutter -Safety and alarm settings 	Safety function	
	Safety function	Disabled Enabled
	Behavior at start of safety	No reaction  Stop Up Down Move to position
	Height position at start of safety in %	0 (0-100)
	Slat position at start of safety in %	0 (0-100)
	Behavior at end of safety	No reaction Up Down Move to position prior safety Accept current automatic position
	Behavior at exceeding cycle time	No reaction  Stop Up Down Move to position
	Height position on exceeding cycle time in %	0 (0-100)
	Slat position on exceeding cycle time in %	0 (0-100)

The safety function is activated if the **safety object** receives a telegram with the object value that you defined with the parameter **Device safety** (). You can define the reaction using the parameter **Behavior at start of safety**.

- **No reaction:** Finish actual task.
- **Stop:** The drive remains in its current position.
- **Up:** The drive moves to the upper end position.
- **Down:** The drive moves to the lower end position.
- **Move to position:** The drive moves to the defined position for height and slat (for blind only).

If the safety object receives a telegram with the object value opposite of that for activation, the safety function is canceled and the output relay adopts the state that you defined in the parameter **Behavior at end of safety**.

- **No reaction**: The drive remains in its current position.
- **Up**: The drive moves to the upper end position.
- **Down**: The drive moves to the lower end position.
- **Move to position prior safety**: The drive returns to the position it had before the safety telegram.
- **Accept current automatic position**: This setting is only useful if the automatic function is active. The drive moves to the last automatic position requested.

The device then waits for a telegram from an external sender within the globally set cycle time. If such a telegram is not received within the monitoring time, the parameter **Behavior at exceeding cycle time** is used to determine what is to happen.

- **No reaction**: The drive remains in its current position. Block for new commands, but finish actual task.
- **Stop**: Block for new commands, and the drive remains in its current position.
- **Up**: The drive moves to the upper end position. Block for new commands.
- **Down**: The drive moves to the lower end position. Block for new commands.
- **Move to position**: The drive moves to the defined position for height and slat (for blind only). Block for new commands.

Group Objects for Central Safety

No.	Name	Object function	Length	Behavior	Data Type
23	Central	Safety	1 bit	Received	1.005 Alarm

Priority

The **safety function** is a 1-bit group object with the highest priority. This means that this object takes precedence over the following group objects:

- **Alarm object / Weather alarm objects / Lock object**
Priority of Functions for Roller Shutter and Blind, page 35
- **Scene object**
- **Central Move up/down blind / roller shutter objects**
- **Blind / roller shutter automatic objects**
- **Blind / roller shutter manual objects**

Alarm Function

In the case of an alarm, the **alarm function** can be used to set each channel to a desired alarm state. The output is disabled for further operation. Only a higher-level function with a higher priority can still be used to switch the output to a different state.

You can activate the **alarm function** individually for each output channel.

The **alarm function** can be parameterized here for each channel.

Master / Ext. 1/2

Output 1+2 / 3+4 / 5
+6 / 7+8

-Blind/roller shutter

-Safety and alarm
settings

Alarm function

Alarm function **Disabled**
Enabled

Alarm **At object value "1"**
At object value "0"

Behavior at start of alarm **No reaction**
Stop
Up
Down
Move to position

Height position at start of alarm in % **0 (0-100)**

Slat position at start of alarm in % **0 (0-100)**

Behavior at end of alarm **No reaction**
Up
Down
Move to position prior alarm
Accept current automatic position

Behavior after bus voltage recovery **Disabled**
Enabled
As before bus voltage failure

Group Objects of the Alarm Function

No.	Name	Object function	Length	Behavior	Data Type
66	Master Output 1+2 name of the channel	Alarm	1 bit	Received	1.005 Alarm

Object Values for Alarm

First select the object value that is to switch on the **alarm function**:

- **At object value "1"**: object value "1" switches on the alarm function. If the object value "0" is received, the alarm function is switched off again.
- **At object value "0"**: object value "0" switches on the **alarm function**. A telegram with the object value "1" deactivates the function again.

The **alarm function** is activated if the **alarm** object receives a telegram with the object value that you defined with the parameter **Alarm**. The reaction is defined by the parameter **Behavior at start of alarm**.

- **No reaction**: Finish actual task.
- **Stop**: The drive remains in its current position.
- **Up**: The drive moves to the upper end position.
- **Down**: The drive moves to the lower end position.
- **Move to position**: The drive moves to the defined position for height and slat (for blind only).

Once the drive has performed the desired action, it remains in this position and cannot be operated while the **alarm function** is active. Only when a function with a higher priority becomes active will the reaction defined there be executed.

If the **alarm** object receives a telegram with the object value opposite of that for activation, the **alarm function** is canceled and the output relay adopts the state that you defined in the parameter **Behavior at end of alarm**.

- **No reaction:** the drive remains in its current position.
- **Up:** the drive moves to the upper end position.
- **Down:** the drive moves to the lower end position.
- **Move to position prior alarm:** the drive returns to the position it had before the alarm telegram.
- **Accept current automatic position:** this setting is only useful if the automatic function is active. The drive moves to the last automatic position requested.

Behavior of the Alarm after Bus Voltage Recovery

Disabled:

The alarm function is not activated after a bus voltage recovery, regardless of the state it had before the bus voltage failure.

Enabled:

After a bus voltage recovery, the alarm function becomes active and the output is switched to the state that you defined via the parameter **Behavior at start of alarm**.

As before bus voltage failure:

The alarm function is brought to the state that was active before the bus voltage failure. If the alarm function was active, the output is controlled by its settings in the parameter **Behavior at start of alarm**.

Priority

The **alarm function** is a 1-bit group object with high priority. The **device safety** function has the highest priority.

The priority order for blind / roller shutter can be defined globally [Priority of Functions for Roller Shutter and Blind, page 35](#). The **alarm** object takes precedence over the following group objects:



- **Weather alarm objects / Lock object**
Priority of Functions for Roller Shutter and Blind, page 35
- **Scene object**
- **Central Move up/down blind / roller shutter objects**
- **Blind / roller shutter automatic objects**
- **Blind / roller shutter manual objects**

Weather Alarm Function

The weather alarms are activated globally on the **Extended settings** tab with the parameter **Global settings for roller shutter and blind**, and the global settings are parameterized there.

There are now 5 different weather alarms available, together with their group objects.

The monitoring of the signals of the activated weather sensors can be carried out cyclically. The device then expects a telegram from the relevant sensor within the cycle time set. If such a telegram is not received within the monitoring time, the associated weather alarm is nevertheless triggered for safety reasons (if, for example, the sensor or the cable connection between sensor and blind channel is defective and no message would be sent in the event of a genuine alarm).

 	Extended settings	Global settings for roller shutter and blind	
		Weather alarm function	Disabled Enabled
		Monitoring time for wind alarm 1	Disabled 1 s ... 12 h
		Monitoring time for wind alarm 2	Disabled 1 s ... 12 h
		Monitoring time for wind alarm 3	Disabled 1 s ... 12 h
		Monitoring time for rain alarm	Disabled 1 s ... 12 h
		Monitoring time for frost alarm	Disabled 1 s ... 12 h

The effect of the **weather alarm functions** can be parameterized here for each channel. You can enable the **weather alarm function** individually for each drive.

	Master / Ext. 1/2	Weather alarm function	
	Output 1+2 / 3+4 / 5 +6 / 7+8 -Blind / roller shutter -Safety and alarm settings	Weather alarm function	Disabled Enabled

With the **weather alarms functions**, you can protect the blinds or roller shutters against adverse weather effects such as wind, rain and frost. In the event of an alarm for one of these 5 possible weather events, the drives move into a safe position and stay there for the duration of the event (depending on the priorities of the other higher-level functions).

New parameters appear for the detailed setting of the **alarm functions** for three wind alarms, one rain alarm and one frost protection alarm.

	Master / Ext. 1/2	Weather alarm function	
	Output 1+2 / 3+4 / 5 +6 / 7+8 -Blind / roller shutter -Safety and alarm settings	React on wind alarm 1	No Yes
		React on wind alarm 2	No Yes
		React on wind alarm 3	No Yes
		Use AND logic for wind alarms	No Yes
		Reaction on wind alarm(s)	Up Down Move to position

	Reaction on rain alarm	Disabled
		Stop
		Up
		Down
		Move to position
	Reaction on frost alarm	Disabled
		Stop
		Up
		Down
		Move to position

First select how the drive is to react to an active **weather alarm**. To protect against damage in the case of excessive wind speeds, you can individually assign one of the three wind sensor signals 1, 2 or 3 to each channel. With the respective activation, the three signals of the **wind alarms** are logically "OR" linked or linked by means of the AND parameter.

When a **weather alarm** becomes active, the drive performs one of the following reactions according to your settings:

- **Disabled:** The weather alarm function is not active.
- **Stop:** The drive remains in its current position (stops).
- **Up:** The drive moves to the upper end position. The weather alarm function is switched on and the alarm function is active.
- **Down:** The drive moves to the lower end position. The weather alarm function is switched on and the alarm function is active.
- **Move to position:** The drive moves to the defined safety position. The weather alarm function is switched on and the alarm function is active.

Once the drive has performed the desired reaction, it remains in this position and cannot be operated while the **weather alarm** is active. Only when a function with a higher priority becomes active will the reaction defined there be executed.



If the drive is to move to a specific safety position, you can define this position using parameters:

 Master / Ext. 1/2 Output 1+2 / 3+4 / 5 +6 / 7+8 -Blind / roller shutter -Safety and alarm settings	Weather alarm function	
	Height position at weather alarm in %	0 (0-100)
	Slat position at weather alarm in %	0 (0-100)

This safety position is valid for all three **weather alarms** if you have selected the parameter value "**Move to position**" as the reaction to a **weather alarm**.

Priority of Weather Alarms

The global priorities for the weather alarms are defined here.

 	Extended settings	Global settings for roller shutter and blind	
		Priority of weather alarms	Wind alarm >Rain alarm >Frost alarm
			Wind alarm > Frost alarm > Rain alarm
		Monitoring time for wind alarm 1	Rain alarm > Wind alarm > Frost alarm
			Rain alarm > Frost alarm > Wind alarm
		Monitoring time for wind alarm 2	Frost alarm > Rain alarm > Wind alarm
			Frost alarm > Wind alarm > Rain alarm

This priority setting applies to all blind and roller shutter channels for which the **weather alarm function** is enabled. The reactions to a **weather alarm** only become active if no **weather alarm** with a higher priority is already active. If a **weather alarm** is reset and another **weather alarm** with a lower priority is active at that time, the reactions of the alarm with the lower priority are now executed.

Group Objects for Weather Alarms

No.	Name	Object function	Length	Behavior	Data Type
18	Central	Wind alarm 1	1 bit	Received	1.005 Alarm
19	Central	Wind alarm 2	1 bit	Received	1.005 Alarm
20	Central	Wind alarm 3	1 bit	Received	1.005 Alarm
21	Central	Rain alarm	1 bit	Received	1.005 Alarm
22	Central	Frost alarm	1 bit	Received	1.005 Alarm

Drive Behavior after End of Weather Alarm

Once the sensor values of the weather sensors have returned to the normal measuring range, the **weather alarms** are deactivated again. You can define a reaction to be performed by the drive as soon as there is no longer any **weather alarm** active:

	Master / Ext. 1/2	Weather alarm function	
	Output 1+2 / 3+4 / 5 +6 / 7+8	Behavior at end of all weather alarms	No reaction
	-Blind / roller shutter		Up
	-Safety and alarm settings		Down
			Move to position prior weather alarm
			Accept current automatic position

The drive then performs the following functions:

- **No reaction:** the drive remains in its current position. The alarm function is terminated.
- **Up:** the drive moves to the upper end position. The alarm function is terminated.
- **Down:** the drive moves to the lower end position. The alarm function is terminated.
- **Move to position prior weather alarm:** the drive returns to the position it had before the weather alarm. The alarm function is terminated.
- **Accept current automatic position:** this setting is only useful if the automatic function is active. The drive moves to the last automatic position requested. The alarm function is terminated.

Failure and Download Behavior

You can enable this function individually for each drive. The behavior of the drive in the case of a bus voltage failure / bus voltage recovery and application download is defined.

 Master / Ext. 1/2 Output 1+2 / 3+4 / 5 +6 / 7+8 -Blind / roller shutter -Safety and alarm settings	Failure and download behavior	
	Failure and download behavior	Disabled Enabled
	Relay state after bus voltage failure	No reaction Stop Up Down
	Relay state after bus voltage recovery	Stop Up Down Move to position As before bus voltage failure
	Height position at bus voltage recovery in %	0 (0-100)
	Slat position at bus voltage recovery in %	0 (0-100)
	Relay state at end of download	Stop Up Down Move to position As before download
	Height position at end of download in %	0 (0-100)
	Slat position at end of download in %	0 (0-100)

Relay Behavior after Bus Voltage Failure

If the bus voltage falls below 18 V, the drive can be switched to a parameterized state. The drive can either be defined as moving **Up** or **Down** or stopped (**Stop**), remain in the state it had before the failure (**No reaction**). At the same time, the current position of the relay is saved in the device.

Possible settings:

- **No reaction:** the drive remains in its current state, i.e. it remains stationary or it continues to execute a current movement until the running times have elapsed.
- **Stop:** the drive stops immediately.
- **Up:** the drive moves up. If it was in the process of moving downwards, it stops and waits for a preset pause on reverse time of 300 ms before starting the upward movement.
- **Down:** the drive moves down. If it was in the process of moving upwards, it stops and waits for a preset pause on reverse time of 300 ms before starting the downward movement.

NOTE: If your settings may cause a change in direction in the event of a bus voltage failure (**Up** or **Down** settings), be sure to take the pause on reverse into account. This is preset to 300 ms for a bus voltage failure. The parameterized value for the drive is not active in this case. If the drive used requires a longer pause on reverse (see manufacturer specifications), then you must not use the settings **Up** or **Down** in order to avoid damage to the drive.

When making settings, note that the higher-level safety functions are not active during the bus voltage failure. In order to prevent this from resulting in damage, it is useful to make the settings in such a way that the drives are in a safe position during a bus voltage failure.

Relay Behavior after Bus Voltage Recovery

In the case of bus voltage recovery, the relay can adopt a parameterized state.

Possible settings:

- **Stop:** the drive stops immediately.
- **Up:** the drive moves to the upper end position.
- **Down:** the drive moves to the lower end position.
- **Move to position:** the drive moves to the defined position for height and slat (for blind only).
- **As before bus voltage failure:** With the parameter “**As before bus voltage failure**”, the relay adopts the state that was saved in the device at the time of the bus voltage failure. Any subsequent manual switchings are overwritten.

Behavior after Download

After the ETS download, the channel can adopt a parameterized state. If an internal defect or a faulty download results in a state in which the application is not operational, the device will not react. The output relays remain in their last position.

If you wish to activate the behavior after ETS download for a drive, you must parameterize a “**relay state at end of download**” for each channel.

Possible settings:

- **Stop:** the drive stops immediately.
- **Up:** the drive moves to the upper end position.
- **Down:** the drive moves to the lower end position.
- **Move to position:** the drive moves to the defined position for height and slat (for blind only).
- **As before download:** the drive remains in its current state after a download.

Priority

Relay states caused by higher-priority functions take precedence over behavior after ETS download.

Example: OR logic operation with parameterized value of the logic object after bus voltage recovery = 1, prevails and switches the output.

Express Settings for Roller Shutter

Roller shutter protects residents, furnishings and plants against too much sun and UV radiation. The roller shutter prevents the excessive heating of rooms from exposure to sunlight. The protection offered by roller shutters against external noise is also not to be underestimated. In the cold season, the layer of air between window and shutter has an insulating effect. This can additionally save heating costs.

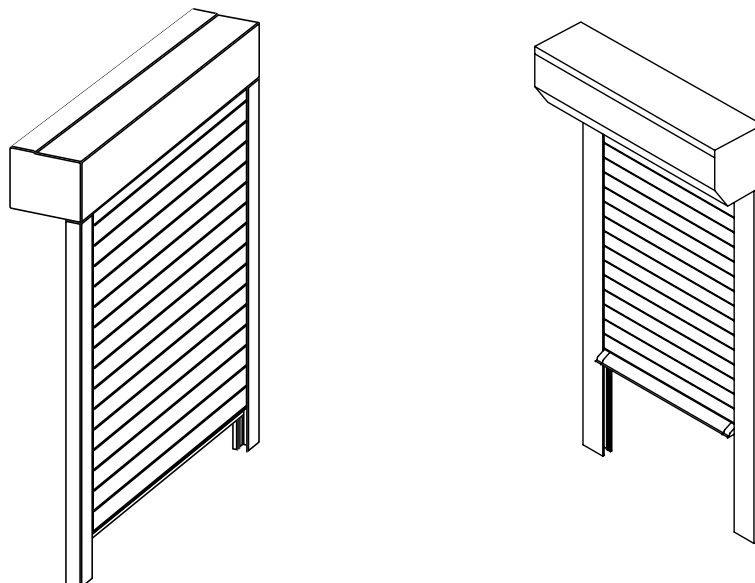

Roller shutters behave in a similar manner to blinds. They lack the slat control functions. For this reason, we refer to the description of the individual functions in the chapter Express Settings for Blind/Roller Shutter, page 69.

Group Objects for Express Settings for Roller Shutter

No.	Name	Object function	Length	Behavior	Data Type
55	Master Output 1+2 name of the channel	Movement in manual mode	1 bit	Received	1.008 Up/Down
56	Master Output 1+2 name of the channel	Stop in manual mode (roller shutter)	1 bit	Received	1.007 Step
57	Master Output 1+2 name of the channel	Height position in manual mode	1 byte	Received	5.001 Percent (0...100%)
70	Master Output 1+2 name of the channel	Feedback for height	1 byte	Sending	5.001 Percent (0...100%)
75	Master Output 1+2 name of the channel	Feedback for moving	1 bit	Sending	1.010 Start/Stop
76	Master Output 1+2 name of the channel	Feedback for last direction	1 bit	Sending	1.008 Up/Down

Name of the Channel



Channel Name, page 72

 Master / Ext. 1/2 Output 1+2 / 3+4 / 5 +6 / 7+8 -Roller shutter	Express settings for roller shutter
--	--

	Name of the channel	Roller shutter Kitchen
--	---------------------	------------------------

Roller Shutter Control Drive Time

 Master / Ext. 1/2 Output 1+2 / 3+4 / 5 +6 / 7+8 -Roller shutter	Express settings for roller shutter	
	Roller shutter control	
	Use same time for up and down	Yes
	Running time: Up/Down (5s...99:59.9 min)	02:00.0
Pause time before reverting (2...255, unit = 100 ms)	5	

 Master / Ext. 1/2 Output 1+2 / 3+4 / 5 +6 / 7+8 -Roller shutter	Express settings for roller shutter	
	Roller shutter control	
	Use same time for up and down	No
	 Running time: Up (5s...99:59.9 min)	02:00.0
Running time: Down (5s...99:59.9 min)	02:00.0	
Pause time before reverting (2...255, unit = 100 ms)	5	

Locking Manual Mode



Locking Manual Mode, page 81

 Master / Ext. 1/2 Output 1+2 / 3+4 / 5 +6 / 7+8 -Roller shutter	Express settings for roller shutter	
	Locking manual mode	Disabled
	Manual locking	At object value "1"
		Enabled
		At object value "0"

Group Objects for Lock of Manual Mode

No.	Name	Object function	Length	Behavior	Data Type
59	Master Output 1+2 name of the channel	Lock of manual mode	1 bit	Received	1.003 Enable

Scenes

Master / Ext. 1/2 Output 1+2 / 3+4 / 5 +6 / 7+8 -Roller shutter Scenes settings	Express settings for roller shutter	
	Scenes	Disabled
		Enabled
	Scene settings	
	Required number of scenes	1 (1-16)
	Overwrite scene values of actuator during download	Disabled
		Enabled
	Time delay for scene processing (0...255, unit = 100 ms)	0
	Scene 1 (1-16)	Disabled
		Enabled
		
	Scene 1 Description	
	Scene 1 Address (0-63)	Scene address 0 - 63
	Dependent: Global Settings for Scenes, page 27	
Scene 1 Address (1-64)	Scene address 1 - 64	
Dependent: Global Settings for Scenes, page 27		
Scene 1 height in %	0 (0-100)	

Group Objects for Scene

No.	Name	Object function	Length	Behavior	Data Type
67	Master Output 1+2 name of the channel	Scene	1 byte	Receives	18.001 Scene control

Central Function for Roller Shutter

Central Function for Blind, page 84

The global settings and explanations of the **central function** can be found in the chapter General Settings, page 20.

Master / Ext. 1/2 Output 1+2 / 3+4 / 5 +6 / 7+8 -Roller shutter	Express settings for roller shutter	
	Central function	Enabled
		Disabled

Group Objects of the Central Function

No.	Name	Object function	Length	Behavior	Data Type
2	Central	Move up/down roller shutter	1 bit	Received	1.008 Up/Down

Status Response

 Master / Ext. 1/2 Output 1+2 / 3+4 / 5 +6 / 7+8 -Roller shutter	Express settings for roller shutter	
	Status of height	<input checked="" type="checkbox"/> Enabled <input type="checkbox"/> Disabled
	Status of moving	<input checked="" type="checkbox"/> Enabled <input type="checkbox"/> Disabled

Group Objects of Status Response of Roller Shutter

No.	Name	Object function	Length	Behavior	Data Type
70	Master Output 1+2 name of the channel	Feedback for height	1 byte	Sending	5.001 Percent (0...100%)
75	Master Output 1+2 name of the channel	Feedback for moving	1 bit	Sending	1.010 Start/Stop
76	Master Output 1+2 name of the channel	Feedback for last direction	1 bit	Sending	1.008 Up/DOWN





Activating Extended Settings for Roller Shutter

To activate the **extended settings for roller shutter**, you must enable them here.

 Master / Ext. 1/2 Output 1+2 / 3+4 / 5 +6 / 7+8 -Roller shutter	Express settings for roller shutter	
	Extended settings for roller shutter	<input type="checkbox"/> No <input type="checkbox"/> Yes



Extended Settings for Roller Shutter

Extended Settings for Blind/Roller Shutter, page 88

	Master / Ext. 1/2	Express settings for blind/roller shutter	
	Output 1+2 / 3+4 / 5 +6 / 7+8		
	-Blind/roller shutter		
		Extended settings for blind/roller shutter	No Yes
	-Extended drive timing	Idle time until upward movement	
		Startup delay	
		Additional startup time	
	-Automatic, Locking & Calibration settings	Priority function	
		Logic function	
	-Safety and alarm settings	Safety function	
		Alarm function	
		Failure and download behavior	

Extended Drive Timing

Extended Drive Timing, page 88

	Master / Ext. 1/2	Extended drive timing	
	Output 1+2 / 3+4 / 5 +6 / 7+8		
	-Blind/roller shutter		
	-Extended drive timing	Idle time until upward movement (0...255, unit = 10 ms)	0
		Startup delay (0...255, unit = 10 ms)	0
		Deceleration delay (0...255, unit = 10 ms)	0

Automatic, Locking and Calibration Settings

Automatic Mode

Automatic Mode, page 90



 Master / Ext. 1/2 Output 1+2 / 3+4 / 5 +6 / 7+8 -Roller shutter -Automatic, Locking & Calibration settings	Automatic, Locking & Calibration settings	
	Automatic mode	
	Automatic mode	Disabled Enabled

Group Objects of Automatic Mode of Roller Shutter

No.	Name	Object function	Length	Behavior	Data Type
60	Master Output 1+2 name of the channel	Movement in automatic mode	1 bit	Received	1.008 Up/DOWN
61	Master Output 1+2 name of the channel	Stop in automatic mode (roller shutter)	1 bit	Received	1.007 Step
62	Master Output 1+2 name of the channel	Height position in automatic mode	1 byte	Received	5.001 Percent (0...100%)

Lock of Automatic Mode

If operation with equal priorities for manual operation and **automatic mode** is not always suitable for your application, you can disable and re-enable **automatic mode** using an additional object as required:

 Master / Ext. 1/2 Output 1+2 / 3+4 / 5 +6 / 7+8 -Blind/roller shutter -Automatic, Locking & Calibration settings	Automatic, Locking & Calibration settings	
	Automatic mode	
	Lock of automatic mode	Disabled Enabled
	 Automatic locking	At object value "1" At object value "0"
	Status of automatic locking	Disabled Enabled

Behavior on deactivating automatic locking via object	No reaction Accept current automatic position
---	--

Once the function “**Lock of automatic mode**” and “**Status of automatic locking**” has been enabled, new group objects are available for the channel.

- The feedback object sends a “1” if automatic locking is active.
- The feedback object sends a “0” if automatic locking is inactive.

Group Objects of Automatic Mode Lock

No.	Name	Object function	Length	Behavior	Data Type
64	Master Output 1+2 name of the channel	Lock of automatic mode	1 bit	Received	1.003 Enable
72	Master Output 1+2 name of the channel	Feedback for automatic mode	1 bit	Sending	1.003 Enable

Depending on the setting, the **automatic locking** is activated or deactivated when a new telegram value is received:

- **“Automatic locking” = “at object value 0”**
 If **“Automatic locking” = “0”**: **automatic locking** is active.
 If **“Automatic locking” = “1”**: **automatic locking** is inactive.
- **“Automatic locking” = “at object value 1”**
 If **“Automatic locking” = “0”**: **automatic locking** is inactive.
 If **“Automatic locking” = “1”**: **automatic locking** is active.

In addition, you can set the behavior of the drive to the end of **automatic locking**.

Furthermore, you can separately define the response of automatic control on receiving a manual control telegram.

Locking Function

Using the **locking function**, you can move a blind / roller shutter to a desired locking position. The state of the output channel cannot be changed by other control commands as long as the lock is active. Only a higher-level function with a higher priority can still be used to move the drive to a different position.

You can enable the locking function individually for each output channel.

Master / Ext. 1/2

Output 1+2 / 3+4 / 5
+6 / 7+8

-Blind/roller shutter

-Automatic, Locking
& Calibration
settings

Locking function

Locking function **Disabled**

 Enabled

Lock **At object value "1"**

 At object value "0"

Status of locking signal **Disabled**

 Enabled

Behavior at start of locking **No reaction**

 Stop

 Up

 Down

 Move to position

Height position at start of locking in % **0 (0 – 100)**

Slat position at start of locking in % **0 (0 – 100)**

Behavior at end of locking **No reaction**

 Up

 Down

 Move to position prior locking

 Accept current automatic position

	Behavior after download	Disabled
		Enabled
		As before download
	Behavior after bus voltage recovery	Disabled
		Enabled
		As before bus voltage failure

Once the “**Locking function**” and “**Status of locking signal**” have been enabled, new group objects are available for the channel.

You can activate and deactivate a channel lock using the **locking object**.

Group Objects of Locking Function

No.	Name	Object function	Length	Behavior	Data Type
65	Master Output 1+2 name of the channel	Lock	1 bit	Received	1.003 Enable
73	Master Output 1+2 name of the channel	Feedback for drive locking	1 bit	Sending	1.003 Enable

If the locking object receives a telegram with the object value that you set for the parameter Lock, all other functions for the channel are disabled. You can define the reaction using the parameter **Behavior at start of locking**.

If the locking object receives a telegram with the object value opposite of that for activation, the lock is canceled and the drive adopts the state that you defined in the parameter **Behavior at end of locking**.

The **Feedback for drive locking object** sends a “1” if the lock is active.



The **Feedback for drive locking object** sends a “0” if the lock is inactive.

Movement Range Limits

Movement Range Limits, page 95

 Master / Ext. 1/2 Output 1+2 / 3+4 / 5 +6 / 7+8 -Blind/roller shutter -Automatic, Locking & Calibration settings	Movement range limits	Disabled
	Movement range limits	Enabled
	Limit movement range	Immediately after bus voltage recovery
		At object value "1" At object value "0"
	Feedback for range limitation	Disabled
		Enabled

 Master / Ext. 1/2 Output 1+2 / 3+4 / 5 +6 / 7+8 -Blind/roller shutter -Automatic, Locking & Calibration settings	Movement range limits	
	Limit movement position	Limit range at lower position

	Upper limit value in % (fix)	0
	Lower limit value in %	100 (0-100)
	Limit movement position	Limit range at upper position
	Upper limit value in %	100 (0-100)
	Lower limit in % (fix)	0
	Behavior at the end of movement restriction	No reaction
		Up
		Down
		Move to position prior to movement restriction Accept current automatic position

Group Objects of Movement Range Limits

No.	Name	Object function	Length	Behavior	Data Type
68	Master Output 1+2 name of the channel	Activate movement range limits	1 bit	Received	1.003 Enable
74	Master Output 1+2 name of the channel	Feedback for range limitation	1 bit	Sending	1.003 Enable

Calibration

The calibrating function is activated centrally on the **Global settings for roller shutter and blind** tab with the parameter **Calibration**.

See Calibration, page 98 and Group Object for Calibration, page 98.

Safety and Alarm Settings

Safety Function for Roller Shutter

Safety Function for Blind, page 102

The global **safety function** is activated on the **Extended settings** tab with the parameter **Device safety** and the global settings are parameterized there.

	Master / Ext. 1/2	Safety function	
	Output 1+2 / 3+4 / 5 +6 / 7+8		
	-Blind/roller shutter		
	-Safety and alarm settings	Safety function	Disabled
			Enabled
		Behavior at start of safety	No reaction
			
			Up



		Down
		Move to position
	Height position at start of safety in %	0 (0-100)
	Slat position at start of safety in %	0 (0-100)
	Behavior at end of safety	No reaction
		Up
		Down
		Move to position prior safety
		Accept current automatic position
	Behavior at exceeding cycle time	No reaction
		Stop
		Up
		Down
		Move to position
	Height position on exceeding cycle time in %	0 (0-100)

Group Objects for Central Safety

No.	Name	Object function	Length	Behavior	Data Type
23	Central	Safety	1 bit	Received	1.005 Alarm

Alarm Function

Alarm Function, page 103

 Master / Ext. 1/2 Output 1+2 / 3+4 / 5 +6 / 7+8 -Blind/roller shutter -Safety and alarm settings 	Alarm function	
	Alarm function	Disabled
		Enabled
	Alarm	At object value "1"
		At object value "0"
	Behavior at start of alarm	No reaction
		Stop
		Up
		Down
		Move to position
	Height position at start of alarm in %	0 (0-100)

	Behavior at end of alarm	No reaction Up Down Move to position prior alarm Accept current automatic position
	Behavior after bus voltage recovery	Disabled Enabled As before bus voltage failure



Group Objects of the Alarm Function

No.	Name	Object function	Length	Behavior	Data Type
66	Master Output 1+2 name of the channel	Alarm	1 bit	Received	1.005 Alarm

Weather Alarm Function

The weather alarms are activated globally on the **Extended settings** tab with the parameter **Global settings for roller shutter and blind**, and the global settings are parameterized there.

Weather Alarm Function, page 105

Extended settings  	Global settings for roller shutter and blind	
	Weather alarm function	Disabled Enabled
	Monitoring time for wind alarm 1	Disabled 1 s ... 12 h
	Monitoring time for wind alarm 2	Disabled 1 s ... 12 h
	Monitoring time for wind alarm 3	Disabled 1 s ... 12 h
	Monitoring time for rain alarm	Disabled 1 s ... 12 h
	Monitoring time for frost alarm	Disabled 1 s ... 12 h
	Priority of weather alarms	Wind alarm->Rain alarm->Frost alarm Wind alarm->Frost alarm->Rain alarm Rain alarm->Wind alarm->Frost alarm Rain alarm->Frost alarm->Wind alarm Frost alarm->Rain alarm->Wind alarm Frost alarm->Wind alarm->Rain alarm

 Master / Ext. 1/2 Output 1+2 / 3+4 / 5 +6 / 7+8 -Blind / roller shutter -Safety and alarm settings	Weather alarm function	
	React on wind alarm 1	No Yes
	React on wind alarm 2	No Yes
	React on wind alarm 3	No Yes
	Use AND logic for wind alarms	No Yes
	Reaction on wind alarm(s)	Up Down Move to position
	Reaction on rain alarm	Disabled Stop Up Down Move to position
	Reaction on frost alarm	Disabled Stop Up Down Move to position
	Height position at weather alarm in %	0 (0-100)
	Behavior at end of all weather alarms	No reaction Up Down Move to position prior weather alarm Accept current automatic position

Group Objects for Weather Alarms

No.	Name	Object function	Length	Behavior	Data Type
18	Central	Wind alarm 1	1 bit	Received	1.005 Alarm
19	Central	Wind alarm 2	1 bit	Received	1.005 Alarm
20	Central	Wind alarm 3	1 bit	Received	1.005 Alarm
21	Central	Rain alarm	1 bit	Received	1.005 Alarm
22	Central	Frost alarm	1 bit	Received	1.005 Alarm

Failure and Download Behavior

Master / Ext. 1/2 ✂ Output 1+2 / 3+4 / 5 +6 / 7+8 -Blind / roller shutter -Safety and alarm settings	Failure and download behavior	
	Failure and download behavior	Disabled Enabled
	Relay state after bus voltage failure	No reaction Stop Up Down
	Relay state after bus voltage recovery	Stop Up Down Move to position As before bus voltage failure
	Height position at bus voltage recovery in %	0 (0-100)
	Slat position at bus voltage recovery in %	0 (0-100)
	Relay state at end of download	Stop Up Down Move to position As before download
	Height position at end of download in %	0 (0-100)

Printed in:
Schneider Electric
35 rue Joseph Monier
92500 Rueil Malmaison - France
+ 33 (0) 1 41 29 70 00

Schneider Electric
35 rue Joseph Monier
92500 Rueil Malmaison
France

+ 33 (0) 1 41 29 70 00

www.se.com

As standards, specifications, and design change from time to time, please ask for confirmation of the information given in this publication.

© – Schneider Electric. All rights reserved.

2601_MTN6705-0008S_MTN6805-0008_SW