

ARGUS Presence Master with IR, 1-10 V

User Guide

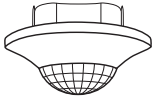

Art. no. MTN5510-1419

Valid from production date week 20/2015**Accessories**

- Surface-mounted housing for ARGUS Presence (Art. no. 550619)
- IR universal remote control (Art. no. MEG5761-0000)
- PlusLink Expander (Art. no. MEG5130-0000)

For your safety**⚠ ⚠ DANGER****HAZARD OF ELECTRIC SHOCK, EXPLOSION, OR ARC FLASH**

Safe electrical installation must be carried out only by skilled professionals. Skilled professionals must prove profound knowledge in the following areas:

- Connecting to installation networks
- Connecting several electrical devices
- Laying electric cables
- Safety standards, local wiring rules and regulations

Failure to follow these instructions will result in death or serious injury.

⚠ ⚠ DANGER**HAZARD OF ELECTRIC SHOCK**

The PlusLink carries an electrical current and the outputs may carry an electrical current even when the device is switched off.

- Before working on the device or the loads, always disconnect the device from the supply via the upstream miniature circuit breaker.

If one or more PlusLink lines are separately fused in your installation then they are not electrically isolated from one another.

- In this case, you should use the PlusLink Expander.

Failure to follow these instructions will result in death or serious injury.

Notice**HAZARD OF EQUIPMENT DAMAGE**

The voltage differential between different phases can damage the device. All devices connected to one or more PlusLink lines must be connected to the same phase.

Failure to follow these instructions can damage the device.

Notice**HAZARD OF EQUIPMENT DAMAGE**

- Ensure that the device is disconnected from its circuit during the insulation resistance test.

Failure to follow these instructions can damage the device.

Getting to know ARGUS Presence Master

The ARGUS Presence master with IR, 1-10 V (referred to below as **ARGUS**) is a presence detector for interior ceiling mounting. The ARGUS comprises a sensor module and a control insert 1-10 V (referred to below as **insert**). The ARGUS can be mounted either in a flush-mounted socket or in surface-mounted housing (available as an accessory). It detects moving heat sources (e.g. people) within an adjustable area of detection and starts a staircase lighting function.

The maximum detection radius is approx. 7 m. The angle of detection is 360°. As long as movement is detected, the connected load remains switched on. The adjustable overshoot time only begins when no further movements are detected (trigger function).

The sensor module is equipped with a light sensor with an adjustable brightness threshold so that the lighting is only switched on below a specified brightness threshold (movement detector function). If there is sufficient natural light, the presence function allows the sensor module to switch off the lighting even when a person is present.

i The specified detection radius and brightness threshold refer to average conditions and a recommended mounting height of approx. 2.50 m and should therefore be taken as guide values. The range can vary greatly when the temperature fluctuates.

The switchable light control keeps the lighting in the room at a constant brightness. The sensor module permanently measures the brightness in the room and keeps it at an adjustable setpoint.

You can switch between the "automatic mode", "24 h on" and "24 h off" modes via an IR remote control.

The insert makes it possible to switch a staircase lighting function and enables light control.

- 1-10 V insert
- Sensor module:**
brightness-dependent staircase lighting function, light control, automatic or semi-automatic mode

With the insert, you can control controllable 1-10 V EBs or electronic transformers with a 1-10 V interface.

You can connect ohmic, inductive and capacitive 1-10 V loads to the switched phase.

The insert also comes with a **PlusLink** input, with which you can control the ARGUS from another location. The insert, along with the sensor module, is the receiving device and is controlled via **PlusLink (PL)** by transmitting devices.

Transmitting devices are, for instance:

- ARGUS Presence slave
- Plus side controller, 2-gang
- mechanical push-buttons

You can use the PlusLink input to access various functions and operating modes with a mechanical push-button or the "Plus side controller, 2-gang". The automatic, semi-automatic and presentation mode can be used for operation with a light control or with a staircase lighting function.

- **Automatic mode:** the light control and staircase lighting functions are started and stopped automatically. A push-button can also be actuated to manually start the functions and activate overshoot time.
- **Semi-automatic mode:** the light control and staircase lighting functions can only be started manually by actuating the push-button. The functions stop depending on movement and brightness levels or when the push-button is actuated.
- **Presentation mode:** e.g. when a video is shown the lighting remains switched off even if movement is detected. Functions are always activated manually (push-button actuated three times). Functions are always deactivated depending on movement or manually (push-button actuated once).
- **Change setpoint:** The desired brightness level for the light control function can be increased or decreased by holding the push-button down (> 5 s).

The "Plus side controller, 2-gang" can be used to switch between automatic mode, "24 h on" and "24 h off". When semi-automatic mode is activated it is also possible to switch to the "24 h staircase lighting circuit".

To be able to use the PlusLink, you require a separate core in your installation.

Recommended cables for PL installation	Maximum total cable sections in a PL line
NYM-J 3x1.5 mm ²	100 m
NYM-J 4x1.5 mm ²	80 m
NYM-J 5x1.5 mm ²	65 m

Notice**HAZARD OF EQUIPMENT DAMAGE**

- Only connect the 1-10 V EB (max. 25 per insert) to the 1-10 V control outputs.
- The 1-10 V control output (+,-) does not have surge protection. Connecting AC 220/230 V will destroy the insert.
- Make sure the polarity of the 1-10 V control output (+,-) is correct.
- Operate the insert only on a sinusoidal mains voltage.

Failure to follow these instructions can damage the device.

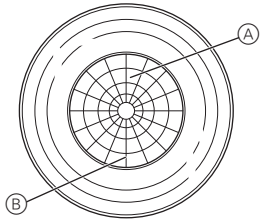
Connections, displays and operating elements**Front:**

- (A) red LED (in test mode)
- (B) green LED (for 24-h staircase lighting circuit)

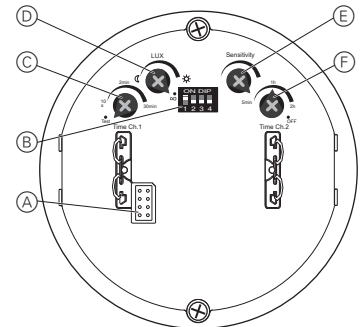
Rear:

- (A) Module interface
- (B) DIP switches
 - 1: Presence function/movement detector function
 - 2: 24-h staircase lighting circuit
 - 3: Prewarning
 - 4: Light control
- (C) Potentiometer for overshoot time
- (D) Potentiometer for brightness threshold
- (E) Potentiometer for sensitivity
- (F) Potentiometer automatic mode / semi-automatic mode ("OFF" position)

Selecting the installation site

- Only mount the sensor module in positions that allow the desired area to be monitored effectively.

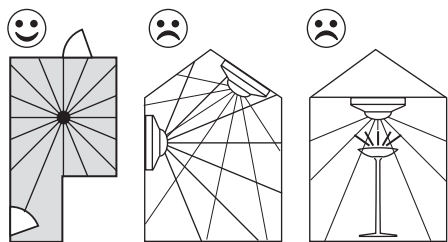

- Install the sensor module on the ceiling, if at all possible in the centre of the room.
- Do not install the sensor module on inclines or walls.
- Install the sensor module at least 0.5 m away from lights.
- The recommended mounting height is 2.50 m. Any mounting height which deviates from this will affect the area of detection.
- Maximum area of detection of the sensor module: 360° angle of detection, approx. 7 m detection radius.

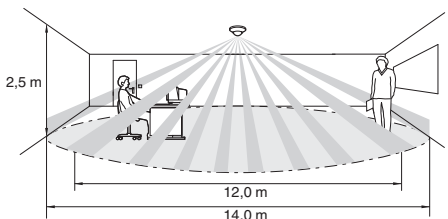

- Inner/outer area of detection
 - inner area of detection (approx. 6 m radius): movement detection of a seated person due to less movement
 - outer area of detection (approx. 7 m radius): movement detection of a person walking due to increased movement
- In order to ensure continuous monitoring, e.g. of a long hall, the areas of detection of the individual sensor modules have to intersect.
- Movement/presence detectors detect objects that radiate heat. You should select an installation site that will not result in undesired heat sources being detected, such as:
 - switched-on lamps in the area of detection
 - open fires (such as in fireplaces)
 - moving curtains, etc., that cause a different temperature in their surrounding environment due to strong sunlight
 - windows where the influence of alternating sunlight and clouds could cause rapid changes in temperature
 - larger heat sources (e.g. cars), that are detected through windows
 - sunlit rooms with reflecting objects (e.g. the floor), which can be the cause of rapid changes in temperature
 - windowpanes heated up by sunlight
 - dogs, cats, etc.

- To prevent faulty operation, the insert should be installed in a wind-resistant flush-mounted socket. With flush-mounted sockets and pipe cabling systems, a draught of air at the rear of the equipment can trigger the sensor module.
- Avoid direct sunlight. This can destroy the sensor in extreme cases.

Installation location for master/slave operation

- In order to ensure the room is as well-lit as possible, put the master in the darkest area of the area used. This means the lighting will still turn on when there is already sufficient ambient brightness in some areas.
- When operating with several master devices in one room (multi master), the individual lighting areas have common borders. This poses the risk that these affect each other (optical feedback). Try to avoid multi-master operation. If this is not possible, place the master in an area that is at the maximum possible distance from the bordering lighting areas.

ARGUS installation

Wiring the insert for the application required

Insert as stand-alone device (optionally with mechanical push-button via PlusLink)

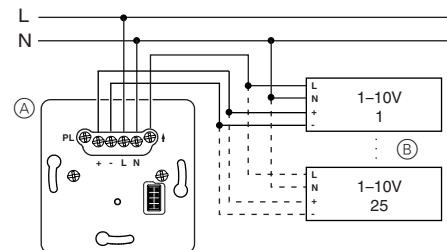

- (A) Control insert 1-10 V
- (B) 1-10 V EB
- (C) Mechanical push-button (trigger mode), optional

Mounting the ARGUS

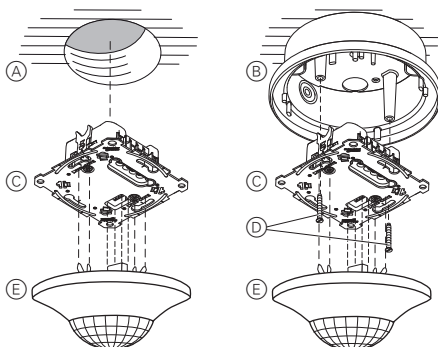

- (A) Flush-mounted socket
- (B) Surface-mounted housing for ARGUS Presence (accessory)
- (C) Insert
- (D) Screws (included with surface-mounted housing)
- (E) Sensor module

i When mains voltage is connected, the sensor module switches the insert on for 30 s and then back off. During the following 2 s, the sensor module does not react to any movement. After this initialisation period has elapsed, the sensor module is ready for operation.

Setting the sensor module

On the rear side of the sensor module, the potentiometer can be used to set the sensor module's sensitivity, brightness threshold and overshoot time.

Additional possible settings using DIP switches:

		Pos. ON (upper)	Pos. OFF (lower)
DIP 1	Presence function	Active	Inactive
DIP 2	24 h staircase lighting circuit via PlusLink	24 h "ON"	24 h "ON" or 24 h "OFF"
DIP 3	Prewarning	Active	Inactive
DIP 4	Light control	Active *	Inactive

i * As soon as the light control is activated, the DIP switches 1-3 get new/additional functions (see „Adjusting the light control“).

Setting the sensitivity

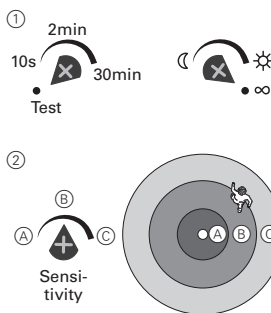

- Activate the test mode and set the brightness threshold to "infinite".
- The red LED lights up when movement is detected.
- Infinitely adjust the sensitivity (max. 7 m detection radius).
- Walk around the area of detection and check whether the sensor module is switching as desired. Adjust the sensitivity if required.

Setting the brightness threshold



- Infinitely set the desired brightness threshold. The sensor module switches below the set brightness threshold.
 - ☾ Detects movement in the dark (approx. 10 lux)
 - ☀ Detects movement during daylight (approx. 1000 lux)
 - ∞ Detects movement independently of brightness
- Check that the sensor module switches at the desired/set brightness. Adjust the brightness threshold if required.

Adjusting the staircase lighting function

You can set the type of staircase lighting function (without/with prewarning) and the overshoot time.

When setting the overshoot time, you specify how long the connected load remains switched on (continuously from 10 s to 30 min.).

The prewarning indicates the end of the overshoot time. The loads are dimmed down slowly. The loads are switched off after the prewarning time has elapsed (30 s, not adjustable).

- Select the type of staircase lighting function and set the overshoot time.

Staircase lighting function without prewarning

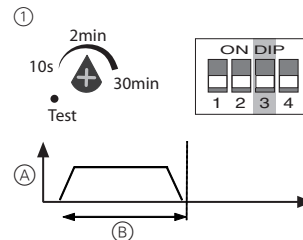

- (A) Dimming without prewarning
- (B) Overshoot time

Staircase lighting function with prewarning

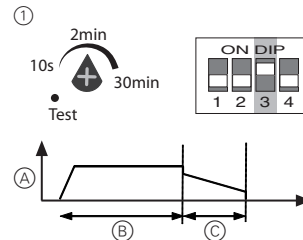

- (A) Dimming with prewarning
- (B) Overshoot time
- (C) Prewarning time (30 s, not adjustable)

Activating/deactivating the presence function

In the case of brightness-dependent movement detection, the sensor module constantly monitors the brightness in the room and compares it to the set brightness threshold. If sufficient natural light is available, the sensor module will

switch the lighting off even if a person is present.

The sensor module's presence function is activated as a factory default. You can deactivate the function ("OFF") and reactivate it ("ON") using DIP switch 1.



When the presence function has been deactivated, the sensor module continues to carry out the movement detector function.

Adjusting the 24 h staircase lighting circuit

DIP switch 2 can be used to set a 24 h staircase lighting circuit which you can retrieve from another location via PlusLink.

The following options are available for this:

- DIP 2 "ON": only switch on the staircase lighting for 24 h via PL
- DIP 2 "OFF": switch the staircase lighting on/off for 24 h via PL

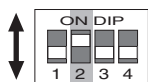

Activating/deactivating semi-automatic mode

Semi-automatic mode is activated via the "OFF" position by the right-hand stop of the potentiometer.

Automatic mode is set as default at the factory and is activated by any position other than "OFF".



Activating/deactivating light control

The sensor module's light control is deactivated as a factory default. You can activate the function ("ON") and deactivate it ("OFF") using DIP switch 4.



Light control

Basic function of light control

Light control keeps the lighting in the room at a constant brightness. The sensor module permanently measures the brightness in the room and keeps it at an adjustable setpoint. When movement is detected, the insert initially dims the lighting to the setpoint value. If the ambient brightness changes, the insert dims the lighting accordingly. If sufficient natural light is available, the sensor module will switch the lighting off even if a person is present.

Example to illustrate light control:

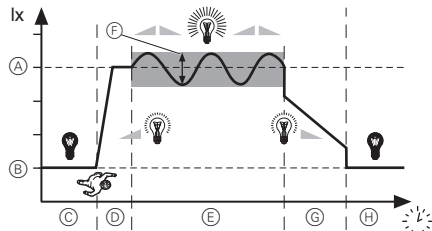

- (A) Setpoint
- (B) Ambient brightness
- (C) Lighting switched off
- (D) Start phase

- (E) Control phase
- (F) Control range
- (G) Prewarning
- (H) Lighting switched off

Adjusting the light control

As soon as the light control is activated via DIP switch 4, the other DIP switches take on a new or additional function:

DIP	Function	Pos. ON (upper)	Pos. OFF (lower)
DIP 1	Response speed	Slow	Fast
DIP 2	Setpoint change	Disabled	Via IR remote control or push-button module
	24 h staircase lighting circuit via PL	24 h "ON"	24 h "ON" or 24 h "OFF"
DIP 3	Adjust start phase	50% brightness of the lighting	Setpoint

Adjusting the response speed

The speed with which the sensor module adjusts the light to the setpoint value can be adjusted using DIP switch 1.

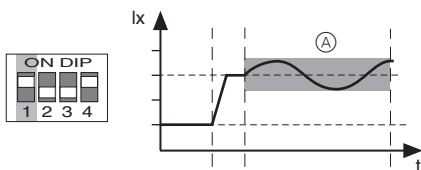

- (A) slow light control

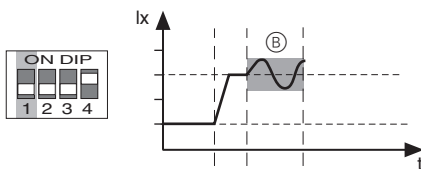

- (B) fast light control

Change setpoint

The setpoint is a desired brightness value that should be observed constantly in the room. This value results from the ambient brightness and the lighting.

You can select whether or not the setpoint value may be altered using DIP switch 2. It can be altered with the IR universal remote control, a mechanical push-button, or the "Plus side controller, 2-gang".

The brightness of the lighting alters accordingly when the setpoint is changed.

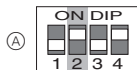

- (A) Setpoint change disabled



- (B) Setpoint change enabled

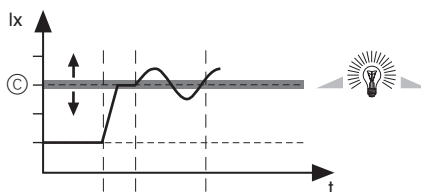

- (C) Change setpoint
 - with IR universal remote control:
 - Push-button 8: increase setpoint
 - Push-button 9: reduce setpoint
 - with mechanical push-button:
 - First actuation: increase setpoint
 - Second actuation: reduce setpoint
 - with Plus side controller, 2-gang:
 - Upper right push-button: increase setpoint
 - Lower right push-button: reduce setpoint

Adjusting the start phase

The start phase with which the sensor module switches on the light can be adjusted using DIP switch 3.

Start at 50% brightness of the lighting

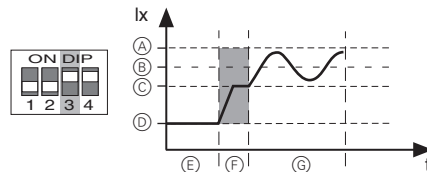

- (A) max. overall brightness (ambient brightness and lighting)
- (B) setpoint
- (C) 50% brightness of the lighting
- (D) ambient brightness
- (E) lighting switched off
- (F) start phase
- (G) control phase

Start with setpoint

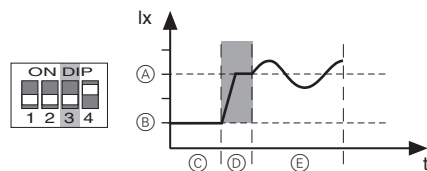

- (A) setpoint
- (B) ambient brightness
- (C) lighting switched off
- (D) start phase
- (E) control phase

Operating sensor module by IR remote control

The DIP switches do not affect the IR function.

You can toggle between three functions of the sensor module by pressing key 10 on the IR remote control (B).

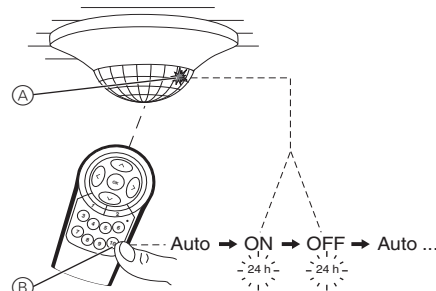

- **Auto** function: The sensor module is in automatic mode and switches the loads on when movement is detected and then off again after the overshoot time has elapsed.
- **24 h "ON"**: Load is switched on permanently for 24 h (no movement detection). Green LED (A) lights up.
- **24 h "OFF"**: Load is switched off permanently for 24 h (no movement detection). Green LED (A) lights up.

Controlling the sensor module from another location

Controlling loads from another location via PlusLink with:

- ARGUS Presence slave
- Side controller Plus, 2-gang
- Mechanical push-button

Example of master/slave control via ARGUS Presence

i Master/slave control via PlusLink is possible in combination with the ARGUS Presence slave.

If the ARGUS Presence slave (A) detects a movement, it sends a trigger command to all local sensor modules in the connected PL lines. In this example, the command is sent to an ARGUS Presence master (B).

The local ARGUS Presence master (B) checks the brightness of the surroundings. The staircase lighting function only starts if the brightness is below the set detection brightness.

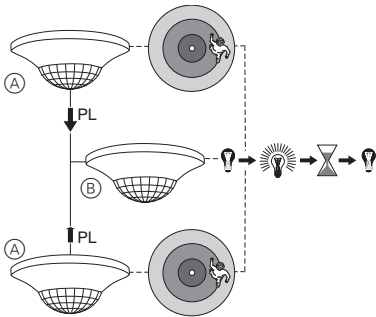

- (A) ARGUS Presence slave on central unit insert
- (B) ARGUS Presence master in PL line

- i** Notes:
- On the central unit insert, the sensor module always sends independently of brightness.
 - The sensor module's DIP switches and potentiometers (except for sensitivity) do not function on the central unit insert.

Operating modes and push-buttons

You can use the PlusLink input to access various functions and operating modes with a mechanical push-button or the right push-button of the "Plus side controller, 2-gang".

The automatic, semi-automatic and presentation operating modes can be used in combination with a light control or with a staircase lighting function. The following examples are related to the light control function.

Automatic mode

In automatic mode, you can start light control or the staircase lighting function independently of brightness by actuating a push-button – even beyond the detection range of the presence detector.

Example of light control in automatic mode

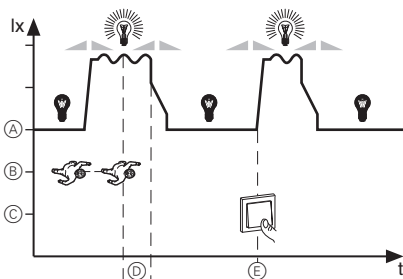

- (A) Lighting
- (B) Movement
- (C) Push-button actuation
- (D) Overshoot time
- (E) Manual start

Automatic switching on depends on brightness.

For a light control switching off also depends on brightness. For a staircase lighting function switching off depends on brightness, only if the presence function is selected.

Semi-automatic mode

In semi-automatic mode it is necessary to actuate a push-button in order to start a light control or staircase lighting function. The manual start is independent of brightness and movement.

Example of light control in semi-automatic mode

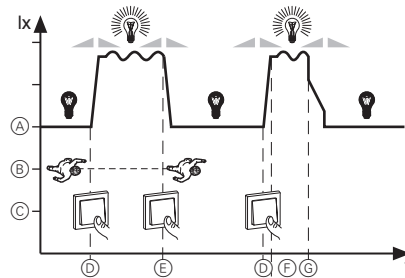

- (A) Lighting
- (B) Movement
- (C) Push-button actuation
- (D) Manual start
- (E) Manual stop
- (F) Overshoot time
- (G) Automatic stop

After automatically switching off, the lighting remains switched off and can only be switched back on manually. Only if a new movement is detected within a period of 5 s after switching off, a new overshoot time starts.

For a light control or staircase lighting function with an activated presence function the lighting is switched off depending on the brightness like in automatic mode.

In contrast to automatic mode, semi-automatic mode is activated via a potentiometer (see section "Setting the sensor module").

Presentation mode

In presentation mode the lighting remains switched off even if movement is detected.

Example of light control with presentation mode

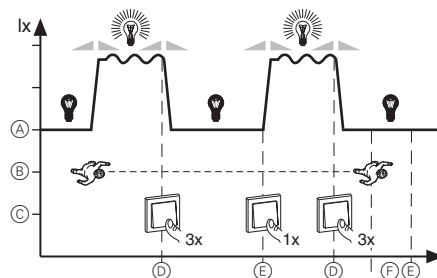

- (A) Lighting
- (B) Movement
- (C) Push-button actuation
- (D) Start presentation mode
- (E) End presentation mode
- (F) Overshoot time

Activating presentation mode:

Press push-button quickly three times in the space of 3 s (< 0.5 s).

Manually deactivating presentation mode:

Quickly press push-button (< 0.5 s).

Technical data

Insert

Nominal voltage:	AC 220/230 V ~, 50/60 Hz
Nominal current:	10 A, $\cos\phi = 0.6$
Load type:	max. 25 controllable EB (1-10 V)
Control current:	Max. 50 mA
Switching capacity to switched phase	
Incandescent lamps:	2200 W
HV halogen lamps:	2000 W
LV halogen lamps with wound transformer:	500 VA
Electronic transformers:	1050 W
Capacitive loads:	10 A, 140 μ F
Neutral conductor:	required
Outputs:	<ul style="list-style-type: none"> • +, - (1-10 V) • Switched phase
Connecting terminals:	Screw terminals for max. 2x 2.5 mm ² or 2x 1.5 mm ²

Protection

Only use the following circuit breakers:

Schneider Electric	16 A	23617
ABB	16 A	S201-B16
ABL Sursum	16 A	B16S1
Hager	16 A	MBN116
Legrand	16 A	03270
Siemens	16 A	5SL61166

Sensor module

Angle of detection:	360°
Number of levels:	6
Number of zones:	136
Number of presence detectors:	4
Recommended mounting height:	2.50 m
Range (can be adjusted under "Sensitivity"):	max. approx. 7 m detection radius
Brightness threshold:	approx. 10 lux to approx. 1000 lux (infinitely adjustable), brightness independent
Overshoot time channel:	approx. 10 s to approx. 30 min (infinitely adjustable), test mode (1 s)
Display elements:	1 red LED 1 green LED
DIP switches:	1: Presence function / movement detector function 2: 24-h staircase lighting circuit 3: Prewarning 4: light control
Connection:	module interface with 8 contact pins



Dispose of the device separately from household waste at an official collection point. Professional recycling protects people and the environment against potential negative effects.

Merten GmbH

Fritz-Kotz-Str. 8
51674 Wiehl - Germany
se.com/contact

