

Universal rotary dimmer insert for LED lamps

Operating instructions

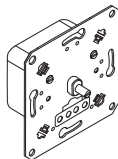

SBD200LED

Art. no. MEG5134-0000

For your safety

⚠️ DANGER

HAZARD OF ELECTRIC SHOCK, EXPLOSION, OR ARC FLASH

Safe electrical installation must be carried out only by skilled professionals. Skilled professionals must prove profound knowledge in the following areas:

- Connecting to installation networks
- Connecting several electrical devices
- Laying electric cables
- Safety standards, local wiring rules and regulations

Failure to follow these instructions will result in death or serious injury.

⚠️ DANGER

HAZARD OF ELECTRIC SHOCK

The outputs may carry an electrical current even when the device is switched off.

- Before working on the loads, always disconnect the device from the supply via the upstream miniature circuit breaker.

Failure to follow these instructions will result in death or serious injury.

Notice



HAZARD OF EQUIPMENT DAMAGE

- Never connect capacitive and inductive loads at the same time.
- The dimmer is designed for sinusoidal mains voltages.
- Only connect dimmable loads.
- Sockets must not be dimmed.
- If the X terminal is used for looping, the insert must be protected with a 10 A miniature circuit breaker.
- Ensure that the device is disconnected from its circuit during the insulation resistance test.

Failure to follow these instructions can damage the device.

Getting to know the universal dimmer

With the Universal rotary dimmer insert for LED lamps (hereafter referred to as **dimmer**) you can switch and dim ohmic, inductive or capacitive loads:

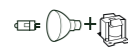
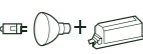
-  Dimmable LED lamps
-  Incandescent lamps (ohmic load)
-  230 V halogen lamps (ohmic load)
-  Low-voltage halogen lamps with dimmable wound transformer (inductive load)
-  Low-voltage halogen lamps with electronic transformer (capacitive load)

The dimmer automatically recognises the connected load. It is overload-proof, short-circuit-proof, protected from overheating and it has a soft-start function.

You can set the dimming range and adjust the operating mode (from trailing edge phase to leading edge phase).

Installing the device

-  Connect three dimmers at most to one cable with 16 A fuse protection.

-  If you do not install the dimmer in a single, standard flush mounting box, the maximum permissible load is reduced due to the decreased heat dissipation:

Load reduced by	When installed
25 %	In cavity walls* Several installed together in combination*
30 %	In 1-gang or 2-gang surface-mounted housing
50 %	In 3-gang surface-mounted housing

* If several factors apply, add the load reductions together.

Wiring the insert

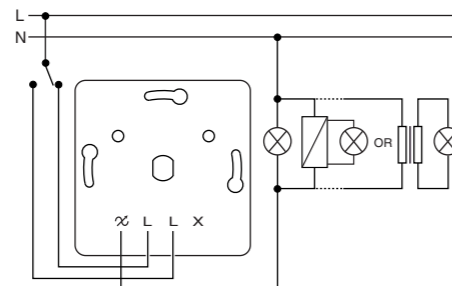

Installing the dimmer

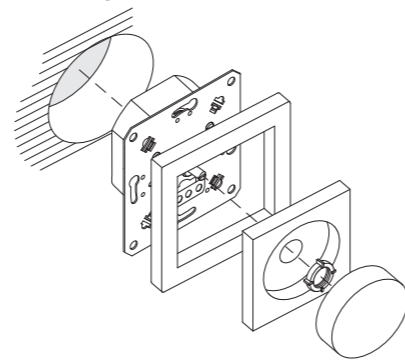

Setting the device

Dimming range

The dimming range of the dimmer can, if necessary, be adapted to the dimming range of lamps from different manufacturers.

Setting the dimming range

-  Depending on the dimming range of the lamp, malfunctions may occur for values near the maximum and minimum brightness. (Refer to the chapter "What should I do if there is a problem?")

Setting the minimum and maximum brightness value

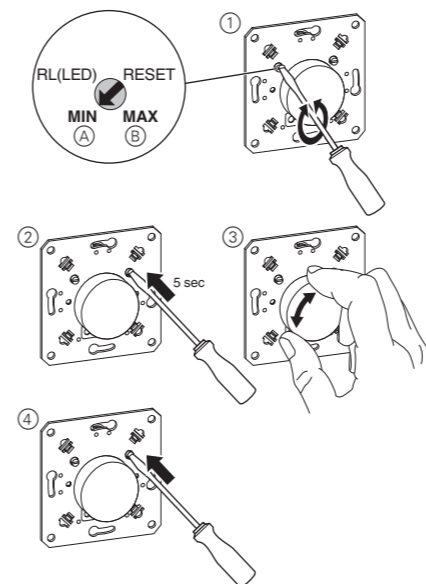

- ① Set the potentiometer to MIN(A)/MAX(B).
- ② Hold the micro button down for 5 seconds. (The lamp lights up briefly.)
- ③ Turn the rotary knob to the desired minimum/maximum brightness.
- ④ Press the micro button briefly. The selected brightness is saved as the minimum/maximum brightness and the set mode is closed.

Operating mode

The default setting of the dimmer is the RC mode. The dimmer recognises the connected load automatically, however this can lead to malfunctions in some lamps (see manufacturer's specifications). In this case you can adjust the operating mode.

Switching the operating mode to RL LED mode

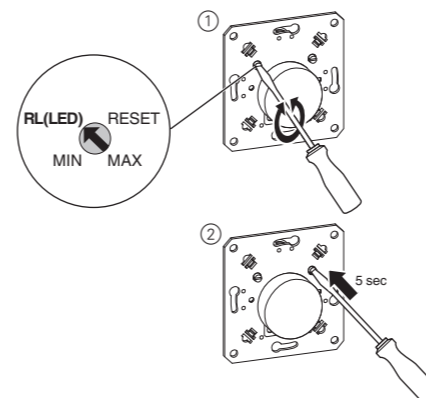

- ① Set the potentiometer to RL(LED).
- ② Hold the micro button down for 5 seconds. (The lamp lights up briefly.)

The operating mode is switched to "leading edge phase for LED lamps" (RL LED mode) and the minimum/maximum brightness value is reset.

-  In the operating mode "leading edge phase for LED lamps" (RL LED mode), LED lamps can only be connected at up to 10 % of the maximum permissible dimmer load.

Operating the device

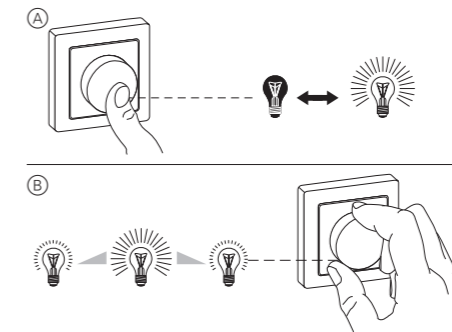

- Press the rotary knob: the connected lamps are switched-on or off.
- Turn the rotary knob either clockwise or anti-clockwise: the connected lamps are dimmed brighter or darker.

Resetting to default mode

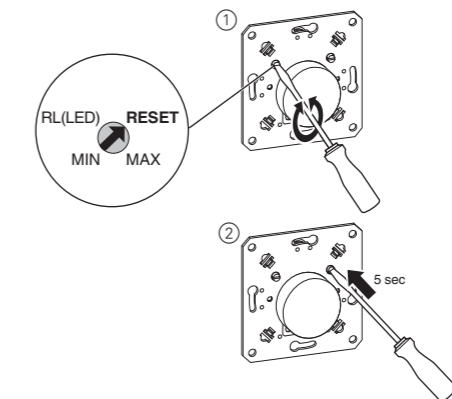

- ① Set the potentiometer to RESET.
- ② Hold the micro button down for 5 seconds. (The lamp lights up briefly.)

The operating mode is switched to "trailing edge phase" (RC mode) and the minimum/maximum brightness value is reset.

What should I do if there is a problem?

The dimmer dims down regularly during operation and cannot be dimmed up again.

- Allow the dimmer to cool down and reduce the connected load.
- The load cannot be switched back on.
- Allow the dimmer to cool down and reduce the connected load.
- Rectify any possible short circuits.
- Renew defective loads.

The load is dimmed to the minimum brightness.

- The circuit is overloaded. -> Reduce load.
- The circuit falls short of the minimum load. -> Increase load.
- Dimming range is incorrect. -> Reduce maximum brightness value.

The load flickers at minimum brightness.

The circuit falls short of the minimum possible brightness value.

- Increase minimum brightness value (set dimming range).

The load flickers continuously.

Incorrect operating mode set.

- Switch operating mode to "leading edge phase for LED lamps" (RL LED mode).
- Alternatively, reset operating mode to default.

The load can only be dimmed slightly.

- Set dimming range.
- Switch operating mode to "leading edge phase for LED lamps" (RL LED mode).

Technical data

Nominal voltage: AC 230 V ~, 50/60 Hz

Switching capacity:

LED lamps (RC mode): 4-200 VA

LED lamps (RL LED mode): 4-40 VA

Incandescent lamps: 4-400 W

230 V halogen lamps: 4-400 W

LV halogen lamps with dimmable wound transformer: 4-400 VA

LV halogen lamps with electronic transformer: 4-400 VA

Neutral conductor: Not required

Connecting terminals: Screw terminals for max. 2.5 mm²

Protection: 16 A circuit breaker

- Properties:
- Short-circuit-proof
 - Overload-proof
 - Soft start
 - Resistant to overheating
 - Automatic load detection



Dispose of the device separately from household waste at an official collection point. Professional recycling protects people and the environment against potential negative effects.

Merten GmbH

Fritz-Kotz-Str. 8
51674 Wiehl - Germany
se.com/contact

Schneider
Electric