

PacT Series FuPacT

Catalog 2025
Fusegear Range from 32 to 1250 A



December, 2025

se.com

Life Is On

Schneider
Electric

Legal Information

The information provided in this Catalog contains description of Schneider Electric products, solutions and services ("Offer") with technical specifications and technical characteristics of the performance of the corresponding Offer.

The content of this document is subject to revision at any time without notice due to continued progress in methodology, design and manufacturing.

To the extent permitted by applicable law, no responsibility or liability is assumed by Schneider Electric and its subsidiaries for any type of damages arising out of or in connection with (i) informational content of this Catalog not conforming with or exceeding the technical specifications, or (ii) any error contained in this Catalog, or (iii) any use, decision, act or omission made or taken on basis of or in reliance on any information contained or referred to in this Catalog.

SCHNEIDER ELECTRIC MAKES NO WARRANTY OR REPRESENTATION OF ANY KIND, WHETHER EXPRESS OR IMPLIED, AS TO WHETHER THIS CATALOG OR ANY INFORMATION CONTAINED THEREIN SUCH AS PRODUCTS AND SERVICES WILL MEET REQUIREMENTS, EXPECTATIONS OR PURPOSE OF ANY PERSON MAKING USE THEREOF.

Schneider Electric brand and any trademarks of Schneider Electric and its subsidiaries referred to in this Catalog are property of Schneider Electric or its subsidiaries. All other brands are trademarks of their respective owners.

This Catalog and its content are protected under applicable copyright laws and provided for informative use only. No part of this Catalog may be reproduced or transmitted in any form or by any means (electronic, mechanical, photocopying, recording, or otherwise), for any purpose, without the prior written permission of Schneider Electric.

Copyright, intellectual, and all other proprietary rights in the content of this Catalog (including but not limited to software, audio, video, text, and photographs) rests with Schneider Electric or its licensors. All rights in such content not expressly granted herein are reserved. No rights of any kind are licensed or assigned or shall otherwise pass to persons accessing this information.

Trademarks

QR Code is a registered trademark of DENSO WAVE INCORPORATED in Japan and other countries.



Environmental Data Program

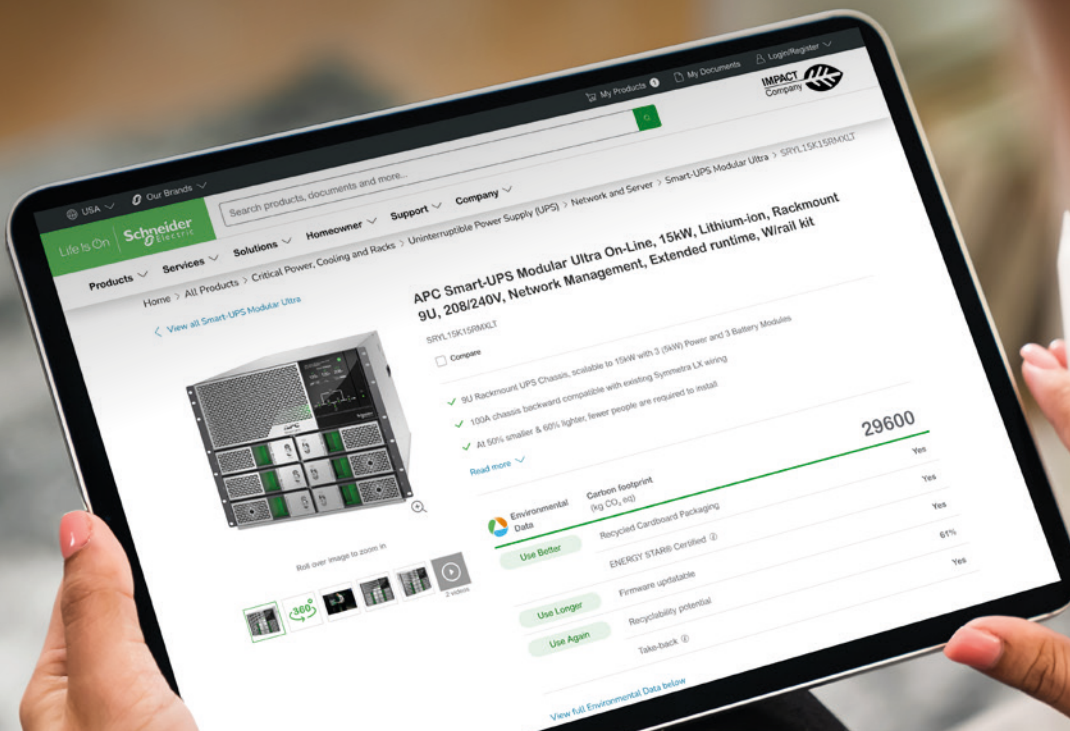

Next-level transparency for better-informed product choices

The Environmental Data Program is a framework for how we measure, categorize, and compare the environmental attributes and footprint of our products.

Using a rigorous, fact-based methodology, the program provides environmental data from across the product lifecycle.

Five data categories across the product lifecycle

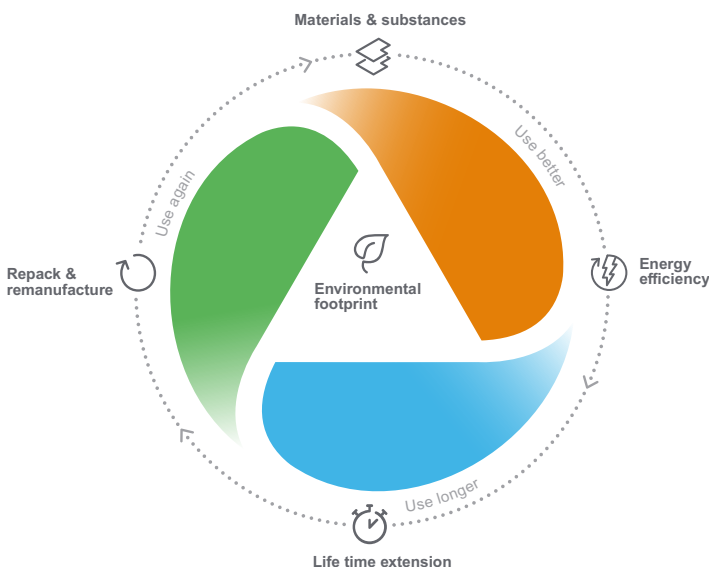

Use Better: How sustainable a product is, including environmental footprint, materials and substances, packaging, and energy efficiency.

Use Longer: How a product's life time can be effectively extended in terms of repairability and updatability.

Use Again: How a product can be reused, from dismantling and remanufacturing to recyclability and manufacturer take back.

With this transparent, verified data, customers and partners are empowered to make conscious environmental choices and accurately evaluate and report on sustainability performance.

All our hardware offers have an associated environmental data available on se.com product pages.



Learn more about the **Environmental Data Program**



An alternative approach to electrical protection

The essentials of electrical protection

Schneider Electric is committed to bringing you one of the most flexible and comprehensive fuse device offer on the market. We bring you essential functions combined with advanced features such as measurement and turnable hooks to deliver a “best in class” solution that provides electrical protection for your industrial applications with single and double breaking switch fuses.

Fuse devices are designed to perform three functions for electrical protection:

- Switch function for circuit on-load control
- Fuse function against short-circuits and overloads
- Isolation from the power circuit.

A complete solution

Schneider Electric offers complete electrical protection for distribution systems including fuse devices that fully integrate in Schneider's functional enclosures (Prisma) and busbar trunking systems (Canalis)

Simple and flexible

- Easy to install and flexible in terms of footprint, cable connections, and product position. Includes mounting plates or can be mounted directly onto busbars or DIN rail.
- Easy to operate and simple to maintain

Fully compatible

Fusegear solutions have been designed to be used with all fuse-links and complying with standard:

- IEC 60269-1 and -2

Fully certified

Fuse offer complies with international standards, certifications and markings:

- IEC 60947-1 and -3
- CCC certificates
- EAC certificates



FuPacT ISFL
160 to 1250 A

FuPacT ISFT
100 to 630 A

Single breaking offer: Fuse switch disconnectors

Functions:

- Short-circuit and overload protection
- Isolation
- On-load switching of circuits



- High level of reliability against short-circuits
- High flexibility on busbar systems thanks to its turnable hooks
- Opening and closing operations are dependent on the operator's action

Built to connect by design

All Schneider Electric components, from electrical devices and busbars, to splitter blocks and switchboards, work together for optimal performance. Their electrical and mechanical functions and communications features integrate seamlessly.

Our range of fuse devices provides:

- Protection for people and property
- Energy quality and availability
- Performance and high uptime
- Easy operation, thanks to standard operating process and simple maintenance.

Combine efficiency and intelligent control thanks to the fuse monitor

Available for the ISFL and ISFT FuPacT ranges, the fuse monitor is more than just an accessory. Its protection and monitoring functions makes it indispensable:

- A monitor solution for the range
- Automatic reset of the fuse monitor once blown fuse is replaced
- Auxiliary contacts for different functions: alarm, tripping of a remote device
- No need of striker fuses, leading to a significant cost reduction



FuPacT GS
32 to 1250 A

Double breaking offer: Switch disconnecter fuses

Functions:

- Short-circuit and overload protection
- Isolation
- On-load switching of circuits



- High level of protection thanks to upstream and downstream double breaking
- Fast opening and closing
- Opening and closing operations occur independently of the operator's action



SINGLE BREAKING FUSE SOLUTIONS
FuPacT ISFT - FUSE SWITCH DISCONNECTORS

FuPacT ISFT devices

FuPacT ISFT helps you remain competitive in today's market. Its features offer more flexibility in terms of mounting and cabling.

FuPacT ISFT is also the smallest product of the market at just 53 mm width for NH 000 fuse-links (100 A).

Fuse switch disconnectors can be mounted and fixed effortlessly!

- **Less stock:** FuPacT ISFT range includes turnable hooks to enable downstream or upstream distribution with the same product.
- **Save time:** less assembling steps. The product can be fixed very quickly for a faster mounting.
- **Enhanced safety:** the product offers optimized user protection against arc flash.

Snap-on busbar cover

- Avoid any risk of coming into contact with busbars

Turnable hooks

- Allows top or bottom cable outlet
- Faster and flexible mounting on the busbar
- Adapted to 60 mm busbar systems

Designed for secondary switchboards

Integrated and extended hand protection

- Prevents fuse-link contact
- Protection against electric arcs

Device locking

- Devices can be sealed and locked

Slidable windows

- Enabling independent testing of individual fuse-links



The smallest product on the market ISFT 100N (100 A)



Less space needed (53 mm width instead of standardized 106 mm)

FuPacT ISFT and ISFL combine efficiency and intelligent control and reduce costs:

The fuse monitor provides:

- Precise location and fast correction of short-circuit and overload faults
- No need of striker-type fuses
- Auxiliary contacts for different functions: alarm, tripping of a remote device, etc.
- Automatic reset of the fuse monitor after blown fuse is replaced





SINGLE BREAKING FUSE SOLUTIONS
FuPacT ISFL - FUSE SWITCH DISCONNECTORS

More flexibility with FuPacT ISFL

FuPacT ISFL is one of the most efficient vertical fuse switch disconnectors ever designed with a compact form and a modular system.

Thanks to its size, FuPacT ISFL doesn't require extra space for current transformer installation. Its interface is standardized for all types of measurement devices.

Measuring device

- Energy consumption control is feasible by the easy installation of a measuring device

Easy to hook

- Turnable contact hooks available for FuPacT ISFL 160 A 3-pole (60 mm busbars)
- Fast mounting with reduced manual operations
- Adapted to all busbar systems: 60/100/185 mm, present in main switchboards

Designed for main switchboards

Fuse monitor

- Precise location and fast correction of short-circuit and overload faults
- Usable only with U < 690 V AC

- Fast connection with variable box terminals

FuPacT ISFL is available in two different versions

- 1-pole switchable dedicated to 185 mm busbars
- 3-pole switchable available for 60/100/185 mm busbars

Same length and depth for size 00 (160 A) to size 3 (630 A)



DOUBLE BREAKING FUSE SOLUTIONS
FuPacT GS - SWITCH DISCONNECTOR FUSES

High performance thanks to FuPacT GS

FuPacT GS offer provides protection for personnel thanks to its double isolation, upstream and downstream when the switch is open.

It also provides high system availability in buildings, infrastructure and even in industrial plants. It is compatible with fuse-links BS, NFC and NH.

3 ways to command FuPacT GS:
front and lateral extended handle for all ratings
and direct handle from 32 to 400 A



Transparent fuse covers
for an easy reading of the fuse type



• Front extended handle

Common auxiliary contacts
from 32 to 1250 A
and auxiliary contacts
with pre-cut function

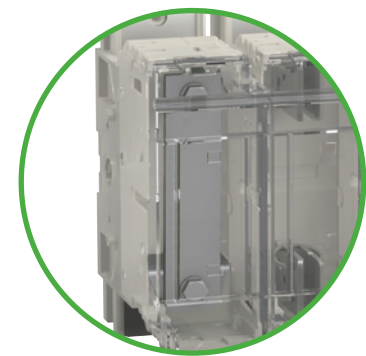

External neutral module
for direct neutral, not switch,
in the same form factor as poles



• Direct extended handle



Handle with 3 positions
ON, OFF, TEST



• Lateral handle

Improve your power distribution with FuPacT GS

- Distribution switchboards.
- Disconnection, isolation, locking and primary control of incoming circuits.
- Categories AC21/AC22 for electrical distribution, AC23 for motor feeders.

+ Power and control your industrial motors with FuPacT GS

- Motor starters: DOL, Star-Delta, softstarters.
- Variable speed starters with frequency converters.
- Machine types: HVAC units, industrial cranes, hoists.
- Industries: paper, steel, ports, automotive, power, mining, rail, oil & gas.

Powering solar efficiency with FuPacT ISFL

Our medium and low-voltage solutions help optimize the string inverter architectures increasingly preferred for solar farm applications while delivering important benefits to you and your developer customers.



AC21B – Compliant for 800 V AC Solar Applications!

The solar farm market is soaring. Yearly installations almost doubled in 2023, exceeding the previous year by 87% [1]. Global investment in the solar sector is rising while wind investments are slowing down. As a result of this, solar maintenance and supervision services are growing to ensure solar farms operate efficiently, reliably, and sustainably.

What's driving solar development?
Residential, commercial, and industrial customers are turning to renewables to reduce their CO2 footprint, advance ESG goals, comply with government regulations, and achieve long-term cost savings.

Skyrocketing demand

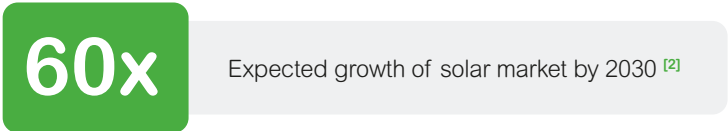
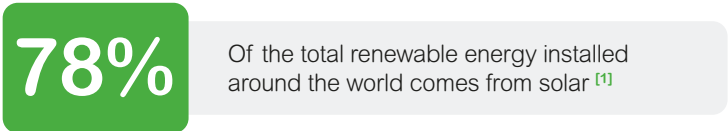

[1] New report: Global solar installations almost double in 2023 but leaves emerging economies in the dark
[2] Schneider Electric Solar Farm Campaign Brief



Empowering Solar Projects: From Design to Delivery

With developers eager to respond to the growing demand for renewable energy, the solar farm market presents significant business opportunities to Schneider Electric partners. Design firms, panel builders, and electrical contractors can help developers overcome four main challenges they face:



Capital costs and time to market

Developers need to design, build, and deliver solar farms faster while optimizing their Levelized Cost of Energy (LCOE), which is the average cost of energy produced by a solar installation over its lifetime.

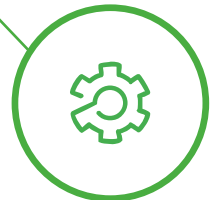

Operations and maintenance efficiency

To succeed, solar farms need to be highly efficient. Developers must optimize operations while safeguarding people and assets and ensuring system reliability and security.

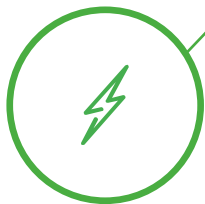

Energy and revenue demands

Developers need to improve solar farm energy yield and generate new revenue streams in anticipation of the end of their government FITs, the feed-in tariffs that ensure an above-market price for the energy they provide to the grid.



Grid integration and repowering

Developers must help future power grids prepare for the rising demand for clean and renewable power.



FuPacT ISFT & ISFL

Tailored Solutions at a Glance

Voltage Usage		415 V AC	500 V AC	690 V AC	800 V AC	
ISFT	ISFT100N/DIN 000 3P Mounting Backplate	LV480750	AC22/23B	AC22B	AC21B	-
	ISFT100N/DIN 000 3P Hook-on 60 mm Busbar - Upstream distribution	LV480751	AC22/23B	AC22B	AC21B	-
	ISFT100N/DIN 000 3P Hook-on 60 mm Busbar - Downstream distribution	LV480752	AC22/23B	AC22B	AC21B	-
	ISFT100 3P Fixed Front Connected	LV480800	AC22/23B	AC22B	AC21B	-
	ISFT160 3P Fixed Front Connected (M8 terminals)	LV480801	AC22/23B	AC22B	AC21B	AC20
	ISFT160 3P Fixed Front Connected (25 to 95 mm ² Cable connectors (Box clamp))	LV480802	AC22/23B	AC22B	AC21B	AC20
	ISFT160 3P Fixed Front Connected with Turnable Hooks	LV480803	AC22/23B	AC22B	AC21B	AC20
	ISFT250 Fixed Front Connected	LV480804	AC22/23B	AC22B	AC21B	AC20
	ISFT250 Fixed Front Connected with Turnable Hooks	LV480805	AC22/23B	AC22B	AC21B	AC20
	ISFT630 Fixed Front Connected	LV480806	AC22/23B	AC22B	AC21B	AC20
	ISFT400 Fixed Front Connected with Turnable Hooks	LV480807	AC22/23B	AC22B	AC21B	AC20
	ISFT630 Fixed Front Connected	LV480808	AC22/23B	AC22B	AC21B	AC20
	ISFT160 Handle Electronic Fuse Monitor	LV480810	AC22/23B	AC22B	AC21B	-
	ISFT250 Handle Electronic Fuse Monitor	LV480821	AC22/23B	AC22B	AC21B	-
ISFT400 Handle Electronic Fuse Monitor	LV480825	AC22/23B	AC22B	AC21B	-	
ISFT630 Handle Electronic Fuse Monitor	LV480828	AC22/23B	AC22B	AC21B	-	
ISFL	ISFL160 60mm Busbar Hook-on Screws M8	LV480850	AC22/23B	AC22B	AC21B	AC21B
	ISFL160 60mm Busbar Hook-on Screws 95mm ²	LV480851	AC22/23B	AC22B	AC21B	AC21B
	ISFL160 DIRECT 100mm Busbar Screws M8	LV480852	AC22/23B	AC22B	AC21B	AC21B
	ISFL160 Direct 100mm Busbar Terminal 95mm ²	LV480853	AC22/23B	AC22B	AC21B	AC21B
	ISFL250 Direct 185mm Busbar Screws M12	LV480856	AC22/23B	AC22B	AC21B	AC21B
	ISFL400 Direct 185mm Busbar Screws M12	LV480857	AC22/23B	AC22B	AC21B	AC21B
	ISFL630 Direct 185mm Busbar Screws M12	LV480858	AC22/23B	AC22B	AC21B	AC21B
	ISFL1250 Busbar 185mm Screws M12	LV480875	AC22/23B	AC22B	AC21B	-
	ISFL 160 with Electronic Fuse Monitor	LV480877	AC22/23B	AC22B	AC21B	-
	ISFL250 with Electronic Fuse Monitor	LV480863	AC22/23B	AC22B	AC21B	-
	ISFL400 with Electronic Fuse Monitor	LV480864	AC22/23B	AC22B	AC21B	-
	ISFL630 with Electronic Fuse Monitor	LV480865	AC22/23B	AC22B	AC21B	-
	ISFL1250 with Electronic Fuse Monitor	LV480876	AC22/23B	AC22B	AC21B	-

Busbar Usage Recommendation		60 mm	100 mm	185 mm	185mm Sidewise/Coupling
ISFT	ISFT100N/DIN 000 3P Mounting Backplate	LV480750	-	-	-
	ISFT100N/DIN 000 3P Hook-on 60 mm Busbar - Upstream distribution	LV480751	●	-	-
	ISFT100N/DIN 000 3P Hook-on 60 mm Busbar - Downstream distribution	LV480752	●	-	-
	ISFT100 3P Fixed Front Connected	LV480800	-	-	-
	ISFT160 3P Fixed Front Connected (M8 terminals)	LV480801	-	-	-
	ISFT160 3P Fixed Front Connected (25 to 95 mm ² Cable connectors (Box clamp))	LV480802	-	-	-
	ISFT160 3P Fixed Front Connected with Turnable Hooks	LV480803	●	-	-
	ISFT250 Fixed Front Connected	LV480804	-	-	-
	ISFT250 Fixed Front Connected with Turnable Hooks	LV480805	●	-	-
	ISFT630 Fixed Front Connected	LV480806	-	-	-
	ISFT400 Fixed Front Connected with Turnable Hooks	LV480807	●	-	-
ISFT630 Fixed Front Connected	LV480808	-	-	-	
ISFL	ISFL160 60mm Busbar Hook-on Screws M8	LV480850	●	●	kit LV480854 2xISFL with kit LV480855
	ISFL160 60mm Busbar Hook-on Screws 95mm ²	LV480851	●	●	kit LV480855 2xISFL with kit LV480855
	ISFL160 DIRECT 100mm Busbar Screws M8	LV480852	●	●	kit LV480856 2xISFL with kit LV480855
	ISFL160 Direct 100mm Busbar Terminal 95mm ²	LV480853	●	●	kit LV480857 2xISFL with kit LV480855
	ISFL250 Direct 185mm Busbar Screws M12	LV480856	-	-	● Coupling with kit LV480891
	ISFL400 Direct 185mm Busbar Screws M12	LV480857	-	-	● Coupling with kit LV480891
	ISFL630 Direct 185mm Busbar Screws M12	LV480858	-	-	● Coupling with kit LV480891
	ISFL1250 Busbar 185mm Screws M12	LV480875	-	-	● Coupling with kit LV480891
	ISFL250 with Electronic Fuse Monitor	LV480863	-	-	● Coupling with kit LV480891
	ISFL400 with Electronic Fuse Monitor	LV480864	-	-	● Coupling with kit LV480891
	ISFL630 with Electronic Fuse Monitor	LV480865	-	-	● Coupling with kit LV480891
ISFL1250 with Electronic Fuse Monitor	LV480876	-	-	● Coupling with kit LV480891	

Fuse Recommendation

Schneider Electric provides a fuse-link offer with NH fuses to a complete solution for our customers.

We offer fuse-links with different curves, available without strikers:



- Fuse-links type aM

Protection of equipment with current peaks like motor applications.



- Fuse-links type gG

Protection of circuits without significant electrical distribution current peaks.

Functional installation

in Prisma product range

Easy implementation

FuPacT fusegear can be installed on mounting plates or mounted directly on the busbar from 60 to 185 mm.
Easy installation with special components for each type of mounting and clear instructions in accordance with standard working practices.

Multiple combinations in switchboard

FuPacT ISFL devices can be installed in the same rows with all the different ratings.
Same accessories are existing to have the same length and new products have been developed to have same length and depth.
Depending on the rating, 6 to 9 devices can be installed per row.



Simplified distribution in switchboard

FuPacT ISFT100 and 160 can be supplied via feeding busbars connected to the main busbars.
All FuPacT ISFT range (except 630 A rating) can be supplied directly by busbars with connection by hook-on.

Full functional-unit performance

Prisma offers a complete set of mounting plates, front plates and prefabricated connection accessories for FuPacT that helps ensure performance and ease of installation.

General contents

FuPacT

Presentation

2

FuPacT ISFT

A

FuPacT ISFL

B

FuPacT GS

C

Catalog numbers

D

> Complementary
technical information



LVPED318033EN

> Prisma P



DESW016EN

> Prisma G



DESW015EN

General description of FuPacT fusegear

2



ISF● fuse-switch disconnectors

FuPacT ISF● (ISFT and ISFL)

ISFT horizontal fuse-switch disconnectors and ISFL vertical fuse-switch disconnectors have the following functions:

- On-load switching of circuits. The speed and force of the operation of this type of fusegear are dependent on the action of the operator
- The fuse-link blades form the moving contacts of the switch
- The fuse-links are mounted in a fuse-carrier assembly
- Via the handle, the fuse-carriers operate the main moving contacts
- Isolation when the fuse-carrier assembly is in the open position (OFF)
- Protection against short-circuits and overloads on distribution circuits. This function is provided by DIN blade-type industrial fuse-links (NH).
- Possibility for ISFL vertical fuse-switch disconnectors to have a 1-pole or 3-pole variant.
- Turnable contact hooks which is advantage in terms of installation. Possibility to have an upstream or downstream distribution with the same product.

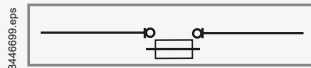

ISF● fuse-switch disconnectors

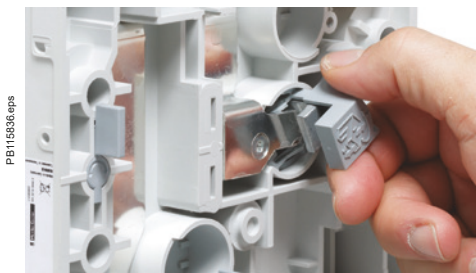

ISFT with turnable hooks

FuPacT GS (GSC, GSD and GSB)

FuPacT GS switch-disconnector fuses provide the following functions:

- On-load switching of circuits. The speed and force of the operation of this type of fusegear are independent of the action of the operator (fast opening and closing).
- Isolation with positive contact indication when the switch is in the open position (OFF). The fuse-link is completely isolated from the power circuit (double breaking technology).
- Protection against short-circuits and overloads on distribution circuits. This function is provided by industrial fuse-links (NFC, DIN, BS) used in conjunction with the switch-disconnector fuse device.
- Safety or emergency stop (red/yellow rotary handle option).



GS● switch-disconnector fuses

FuPacT operating modes

The FuPacT range integrates control, isolation and fuse-carrier functions in a single device. These functions can also be implemented by combining separate components.



FuPacT GS switch-disconnector fuses

Solutions combining separate components

It is also possible to protect distribution circuits and/or motors by combining switch-disconnectors with fuse-links mounted on separate fuse-carriers.

The functions provided by each component are:

- On-load switching of circuits (opening and closing) and isolation (switch-disconnector).
- Protection against overloads and short-circuits (fuse).
- The combination can implement Compact INS or INV switch-disconnectors from 40 to 2500 A.

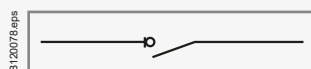

Control

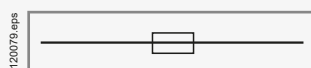

Protection



INS switch-disconnectors



Fuse-link

General description of FuPacT fusegear

Compliance with standards

FuPacT fusegear complies with international standards and recommendations:

- IEC 60947-1: general rules
- IEC 60947-3: switches, disconnectors
- IEC 60947-5.1 and following: control-circuit devices and switching elements; automatic control components.

These standards and recommendations are applied in most countries.

FuPacT fusegear and auxiliaries comply with International standards (IEC 60947-1 and IEC 60947-3).

FuPacT GS and FuPacT ISF● are designed for use with industrial fuse-links complying with the following standards:

- IEC 60269
- BS 88 (only for FuPacT GS)
- DIN 43620 / VDE 0636.

FuPacT GS switch-disconnector fuses are suitable for the control of machine-tools:

- They comply with the requirements of the new machine directive IEC 60204 (EN 60204)
- They comply with French standard NF C 79-130 and the recommendations issued by the CNOMO organisation.

Climatic environment

FuPacT fusegear meets climatic requirements as defined in the following standards:

- IEC 60068-2-30: damp-heat tests under off-load conditions, 95 % relative humidity at 55 °C (hot and humid climate conditions)
- IEC 60068-2-52: salt-mist tests, KB severity 2 tests
- IEC 60068-2-56: damp-heat tests under on-load conditions for 48 hours, environment category C2 following Schneider quality specifications.

The fusegear can therefore be used in all climates.

Degree of pollution

FuPacT fusegear is certified for operation in pollution-degree 3 environments as defined by IEC 60947 standard applying to industrial environments.

Ambient temperature

The FuPacT range can be used between -20 °C and +70 °C. Above 40 °C, you will have to take account of the derating indicated in the documentation.

The devices must be commissioned at the ambient temperature indicated above.

The FuPacT range must be stored in its original packaging at a temperature between -50 °C and +85 °C.

Degree of protection

For FuPacT fusegear with terminal shield, the degree of protection against direct contact complies with standard IEC 60529 (IP index of protection) and IEC 62262:

- With direct rotary handle: IP20/IK07
- With extended rotary handle (FuPacT GS): IP65/IK10
- With extended rotary handle and padlocks: IP65/IK08.

Positive contact indication

IEC 60947-3 standard defines isolation with positive contact indication as follows:

- The isolation position corresponds to the O (OFF) position
- The operating handle cannot indicate the OFF position unless the main contacts are not totally opened
- Locking in the OFF position is not possible unless the main contacts are actually open.

GS● switch-disconnector fuses are suitable for isolation with positive contact indication.

Installation of an extended handle on GS● fusegear does not alter the suitability for isolation.

The isolation with positive contact indication function is certified by testing:

- The mechanical reliability of the position-indication system
- The absence of leakage currents
- Overvoltage withstand capacity between upstream and downstream connections.

Fupact ISFT160			Ith 160A 40°C
Ui 1000V	Uimp 8kV		
IEC 60947-3	50/60 Hz		
Ue (V) / Ie (A)	AC21B	AC22B	AC23B
380/415V	160	160	-
500V	160	160	-
690V	160	-	-
	DC21B	DC22B	
220V / nb pole	160/3	160/3	-
440V / nb pole	125/3	-	-
HD 60269-2	DIN 43620-1		Max(A) 160 Max(W) 12

ISFT label



Fusegear with terminal shields IP20 and IK07



Fusegear in an enclosure or cabinet (extended handle);
GS● only.
IP65 and IK10.



Positive contact indication

A

D



ISFT100N



ISFT100



ISFT160



ISFT250
ISFT400
ISFT630

FuPacT ISFT

Functions and characteristics

Fuse switch-disconnector selection

FuPacT ISFT100N to ISFT630 A-4

Accessories and auxiliaries

FuPacT ISFT100N A-8

FuPacT ISFT160 A-10

FuPacT ISFT250 to ISFT630 A-11

General characteristics: ISFT

FuPacT ISFT100N to ISFT630 A-12

ISFT installation

FuPacT ISFT100N to ISFT630 A-14

Connection and accessories

FuPacT ISFT100N to ISFT630 - Connection A-16

FuPacT ISFT160 to ISFT630 - Reverse distribution A-18

FuPacT ISFT100 and ISFT160 - Connection, coupling A-19

FuPacT ISFT100N, ISFT160 to ISFT400 -

Different installation systems A-20

Fuse monitor

FuPacT ISFT160 to ISFT630 A-22

Insulation

FuPacT ISFT100N to ISFT630 A-24

Fuse-link monitoring and testing

FuPacT ISFT160 to ISFT630 A-25

Control, locking and operation

FuPacT ISFT100N to ISFT630 A-26

Auxiliary contacts and indications

FuPacT ISFT100N to ISFT630 A-28



Other chapters

Presentation 2

FuPacT ISFL B-1

FuPacT GS C-1

Catalog numbers D-1

FuPacT ISFT

Installation recommendations

Possible installation positions and mounting

FuPacT ISFT100N to ISFT630..... A-30

Implementation and power dissipation

FuPacT ISFT A-31



Other chapters

Presentation.....	2
FuPacT ISFL.....	B-1
FuPacT GS.....	C-1
Catalog numbers	D-1

FuPacT ISFT

Dimensions and connection

FuPacT ISFT100N	A-33
Dimensions and mounting	A-33
Front panel cut-outs - Connection and accessories	A-34
FuPacT ISFT100	
Dimensions	A-35
Mounting and front panel cut-outs	A-36
Connection and accessories	A-37
FuPacT ISFT160	
Dimensions	A-39
Mounting and front panel cut-outs	A-40
Connection and accessories	A-41
FuPacT ISFT250 to 630	
Dimensions and mounting	A-43
Mounting and front panel cut-outs	A-44
Connection and accessories	A-45

Wiring diagrams

FuPacT ISFT	A-47
--------------------------	------



Other chapters	
Presentation	2
FuPacT ISFL	B-1
FuPacT GS	C-1
Catalog numbers	D-1

Fuse switch-disconnector selection

FuPacT ISFT100N to ISFT630

A



ISFT100N



ISFT100



ISFT160



ISFT250-400-630

Fuse switch-disconnectors

Number of poles / type of fuse-link IEC 60269-2-1 Section 1

Electrical characteristics as defined by IEC 60947-1 / IEC 60947-3

Conventional thermal current (A)	In free air	I_{th}	at 40 °C
	Maximum fuse power dissipation (W)		
	In enclosure	I_{the}	at 40 °C
	Maximum fuse power dissipation (W)		

Rated insulation voltage (V) **U_i** AC 50/60 Hz / DC

Rated impulse withstand voltage (kV) **U_{imp}**

Rated operational voltage (V) **U_e** AC 50/60 Hz
DC

Rated operational voltage AC20 and DC20 (V) **U_e**

Rated operational current (A) **I_e** AC 50/60 Hz

220/240 V

380/415 V

440/480 V ^[1]

500 V

660/690 V

DC/poles in series

220 V /no. of poles

440 V /no. of poles

Rated duties Uninterrupted duty

Breaking Capacity with Fuses (kA RMS) **I_q** 415 V AC
500 V AC
690 V AC

Short circuit making capacity (kA peak) / Fuse nominal current (A) **I_{cw} (1s) / I_{cm} / I_n fuse** 415 V

Switch-disconnector with fuse protection (fuse link) ^[2] 500 V

690 V

Endurance (category B) (CO cycles) Mechanical

Electrical AC AC22B 415 V

AC23B 415 V

AC22B 500V

AC21B 500V

AC22B 690V

AC21B 690 V

Suitability for isolation

Positive contact indication

Pollution degree

Control

Direct front rotary handle (operator-dependent opening and closing)

Locking Padlocks
Lead seal

Indication auxiliaries

Auxiliary contacts

Fuse monitor

Installation and connection accessories

Possible mounting positions Horizontal
Vertical

Bare cable connectors

Other connectors For bare Cu/Al cables
For flexible bars

Distribution connectors

Lugs for copper cables

Incoming connector for feeding busbars

Terminal shields

Dimensions and weight

Overall dimensions H x W x D (mm) 3P

Approximate weight without fuse-links (kg) 3P

[1] Suitable for 480 V NEMA.

[2] Fuse-switch disconnectors with fuse-links.

[3] AC23B 250 A.

[4] AC23B 400 A.

Fuse switch-disconnector selection

FuPacT ISFT100N to ISFT630



ISFT100N		ISFT100		ISFT160		ISFT250		ISFT400		ISFT630	
3P/DIN (NH)		3P/DIN (NH)		3P/DIN (NH)		3P/DIN (NH)		3P/DIN (NH)		3P/DIN (NH)	
100		100		160		250		400		630	
9		9		12		23		34		48	
100		100		160		250		400		630	
9		9		12		23		34		48	
1000		800		1000		1000		1000		1000	
6		6		8		8		8		8	
690		690		690		690		690		690	
440		440		440		440		440		440	
800		800		800		800		800		800	
AC21B	AC22B	AC21B	AC22B	AC21B	AC22B	AC21B	AC22B	AC21B	AC22B	AC21B	AC22B
100	100	100	100	160	160	250	250 ^[3]	400	400 ^[4]	630	630
100	100	100	100	160	160	250	250 ^[3]	400	400 ^[4]	630	630
100	100	100	-	160	160	250	250	400	400	630	630
100	100	100	-	160	160	250	250	400	400	630	-
100	-	100	-	160	-	250	250	400	400	630	-
DC21B	DC22B	DC21B	DC22B	DC21B	DC22B	DC21B	DC22B	DC21B	DC22B	DC21B	DC22B
100/3	100/3	100/3	-	160/3	160/3	250/3	250/3	400/3	400/3	630/3	630/3
100/3	100/3	100/3	-	125/3	-	250/3	-	400/3	-	630/3	-
⊙		⊙		⊙		⊙		⊙		⊙	
80		80		80		80		80		80	
80		80		80		80		80		80	
80		80		80		80		50		80	
3.5kA/5.1kA/100A		3kA/5kA/100A		5kA/5kA/160A		8.6kA/15kA/250A		15.2kA/22.1kA/400A		20.4kA/25.2kA/630A	
3.5kA/5.1kA/100A		3kA/5kA/100A		5kA/5kA/160A		8.6kA/15kA/250A		15.2kA/22.1kA/400A		20.4kA/25.2kA/630A	
3.5kA/5.1kA/100A		3kA/5kA/100A		5kA/5kA/160A		8.6kA/15kA/250A		15.2kA/22.1kA/400A		20.4kA/25.2kA/630A	
2000		2000		1600		1600		1000		1000	
300		300		200		200		200		200	
-		-		-		200		200		200	
300		-		200		200		200		200	
-		300		200		200		200		200	
-		-		-		200		200		-	
300		300		200		200		200		200	
⊙		⊙		⊙		⊙		⊙		⊙	
⊙		⊙		⊙		⊙		⊙		⊙	
3		3		3		3		3		3	
⊙		⊙		⊙		⊙		⊙		⊙	
-		-		-		-		-		-	
⊙		⊙		⊙		⊙		⊙		⊙	
⊙		⊙		⊙		⊙		⊙		⊙	
-		-		⊙		⊙		-		-	
-		-		⊙		⊙		⊙		⊙	
-		-		⊙		⊙		⊙		⊙	
-		⊙		⊙		-		-		-	
-		-		⊙		⊙		⊙		⊙	
-		-		⊙		-		-		-	
⊙		-		⊙		⊙		⊙		⊙	
216 x 53 x 80		141 x 89 x 71		206 x 106 x 80		306 x 184 x 110		306 x 210 x 130		306 x 250 x 130	
0.54		0.46		0.60		2.00		2.00		3.50	

Fuse switch-disconnector selection

FuPacT ISFT100N to ISFT630

A



PE115837.eps

ISFT100N



PE115838.eps

ISFT100



PE115839.eps

ISFT160



PE115835.eps

ISFT630

Fuse switch-disconnectors

Type of fuse-link

- DIN/NH00
- DIN/NH00
- DIN/NH1
- DIN/NH2
- DIN/NH3

Installation and connection

- Symmetrical rail
- Direct connection on backplate
- Hook-on connection to 60 mm busbars
- Tightening torque (Nm)

Temperature derating (with gG fuse-link) ^{[1][2]}

"Vertical mounting" fuse-links in vertical position	Ith (A)	40 °C
		45 °C
		50 °C
		55 °C
		60 °C
		65 °C
		70 °C
"Horizontal mounting" fuse-links in horizontal position	Ith (A)	40 °C
		45 °C
		50 °C
		55 °C
		60 °C
		65 °C
		70 °C
Degree of protection (from the front face and inclosed position)		IP3X
Mechanical shock		IK07

[1] Derating data is based on:
 - the maximum rating for fuse-links intended for the device,
 - maximum power dissipation.
 [2] For installation on a ceiling, derate an additional 10 %.

Functions and characteristics

Fuse switch-disconnector selection

FuPacT ISFT100N to ISFT630

	ISFT100N	ISFT100	ISFT160	ISFT250	ISFT400	ISFT630
	○	○	○	-	-	-
	-	-	○	-	-	-
	-	-	-	○	-	-
	-	-	-	-	○	-
	-	-	-	-	-	○
	○	○	-	-	-	-
	○	○	○	○	○	○
	○	-	○	○	○	-
	see page A-31					
	100	100	160	250	400	630
	95	95	152	238	380	599
	90	90	144	225	360	567
	85	85	136	213	340	536
	80	80	128	200	320	504
	75	75	120	188	300	473
	70	70	112	175	280	441
	100	100	160	250	400	630
	95	95	152	238	380	599
	90	90	144	225	360	567
	85	85	136	213	340	536
	80	80	128	200	320	504
	75	75	120	188	300	473
	70	70	112	175	280	441
	○	○	○	○	○	○
	○	○	○	○	○	○



Accessories and auxiliaries

FuPacT ISFT100N

FuPacT ISFT100N

DB40852.ai

A

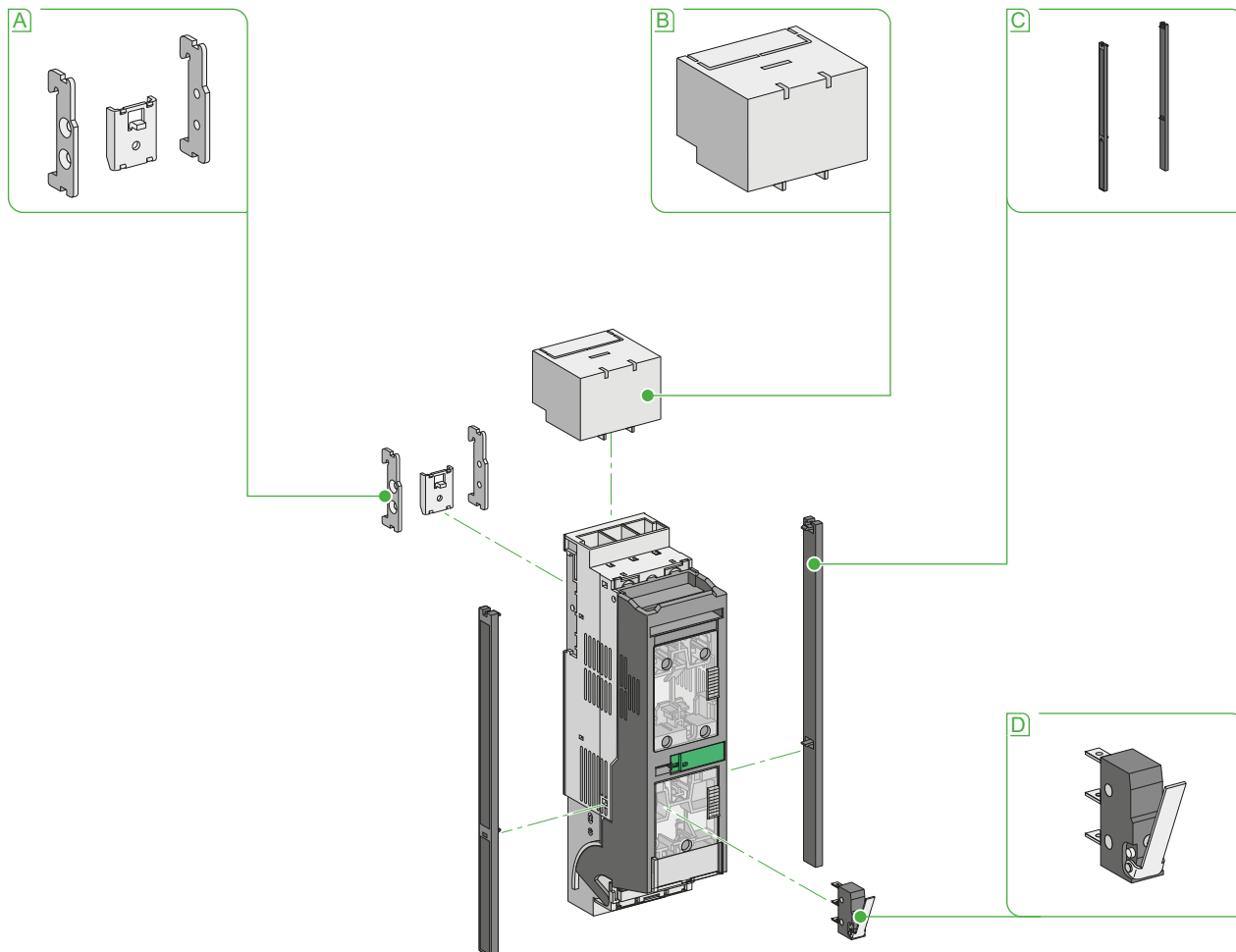

A DIN rail fixing kit

B Terminal cover

C Laterally attachable support profile

D NO + NC auxiliary changeover contacts

Functions and characteristics

Accessories and auxiliaries

FuPacT ISFT100

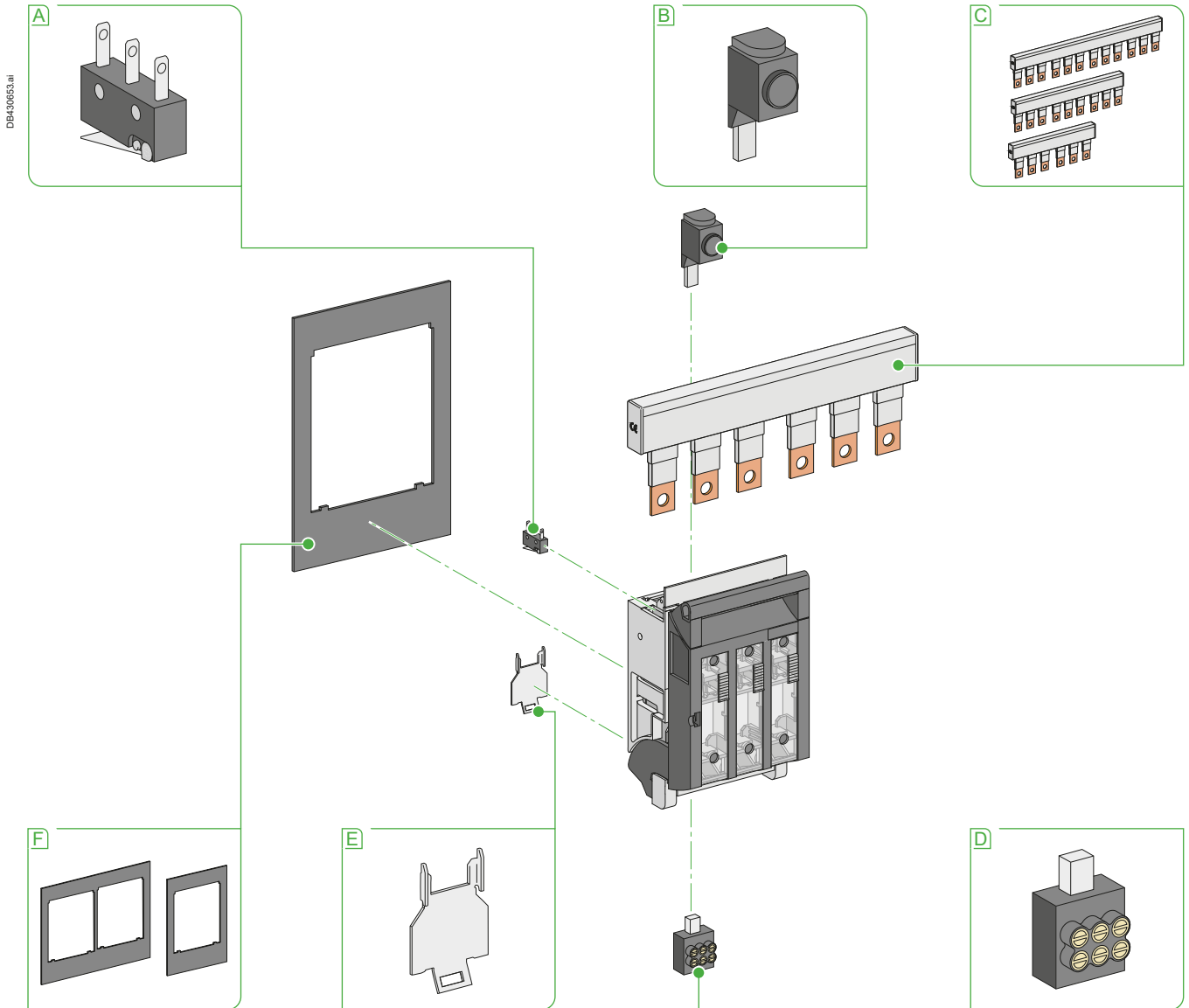

- A** NO + NC auxiliary changeover contacts
- B** Incoming connector for feeding busbars

- C** Feeding busbars to supply :
 - 2 devices
 - 3 devices
 - 4 devices
- D** Distribution connector

- E** Accessory for mounting on DIN rail
- F** Escutcheons for:
 - 1 device
 - 2 devices

Accessories and auxiliaries

FuPacT ISFT160

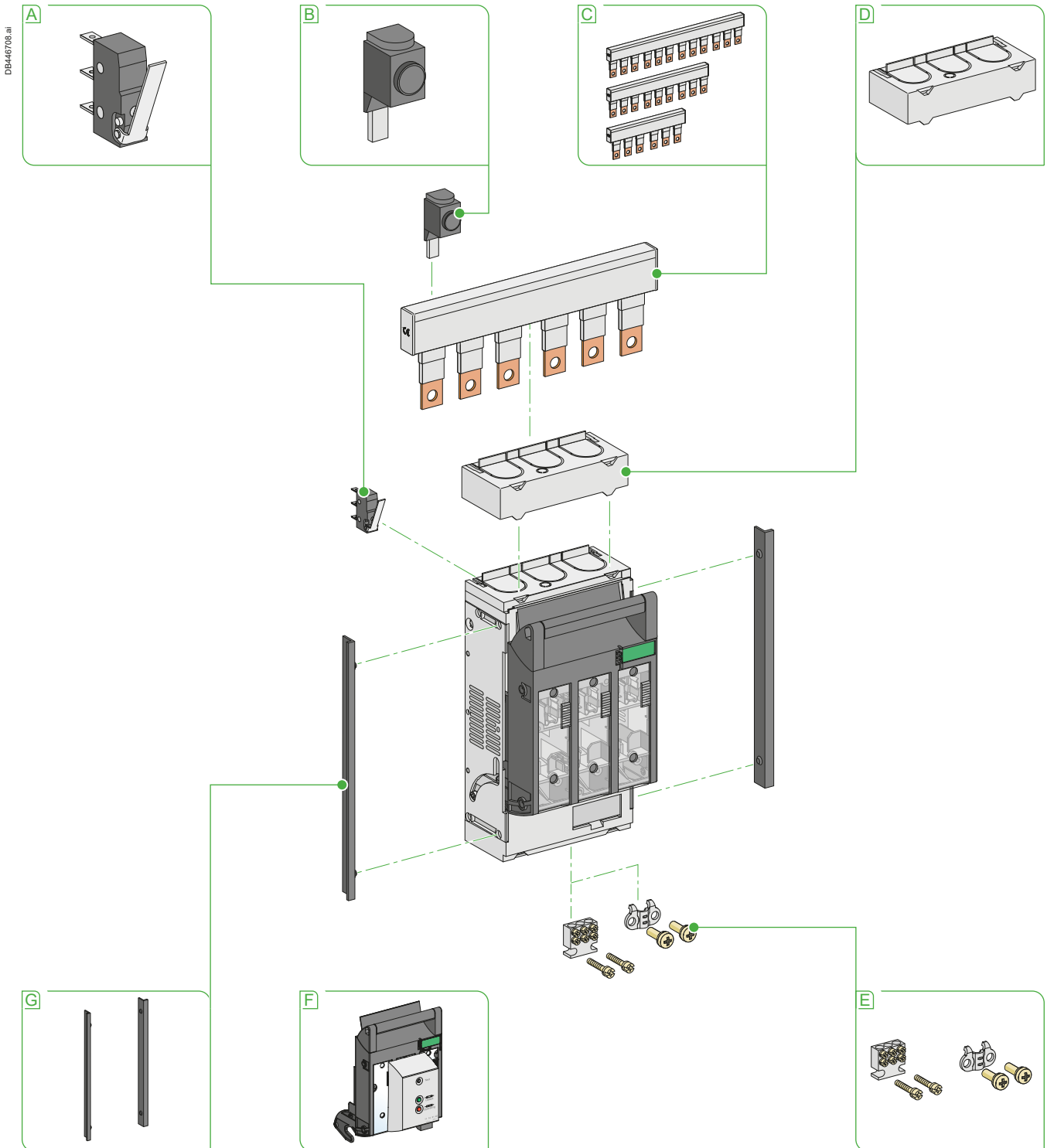

- A** NO + NC auxiliary changeover contacts
- B** Incoming connector for feeding busbars
- C** Feeding busbars to supply :
 - 2 devices
 - 3 devices
 - 4 devices

- E** Connectors for :
 - bare cable
 - distribution
 - flexible bar
- F** Fuse monitor
- G** Laterally attachable support profile

D Long terminal shield

Functions and characteristics

Accessories and auxiliaries

FuPacT ISFT250 to ISFT630

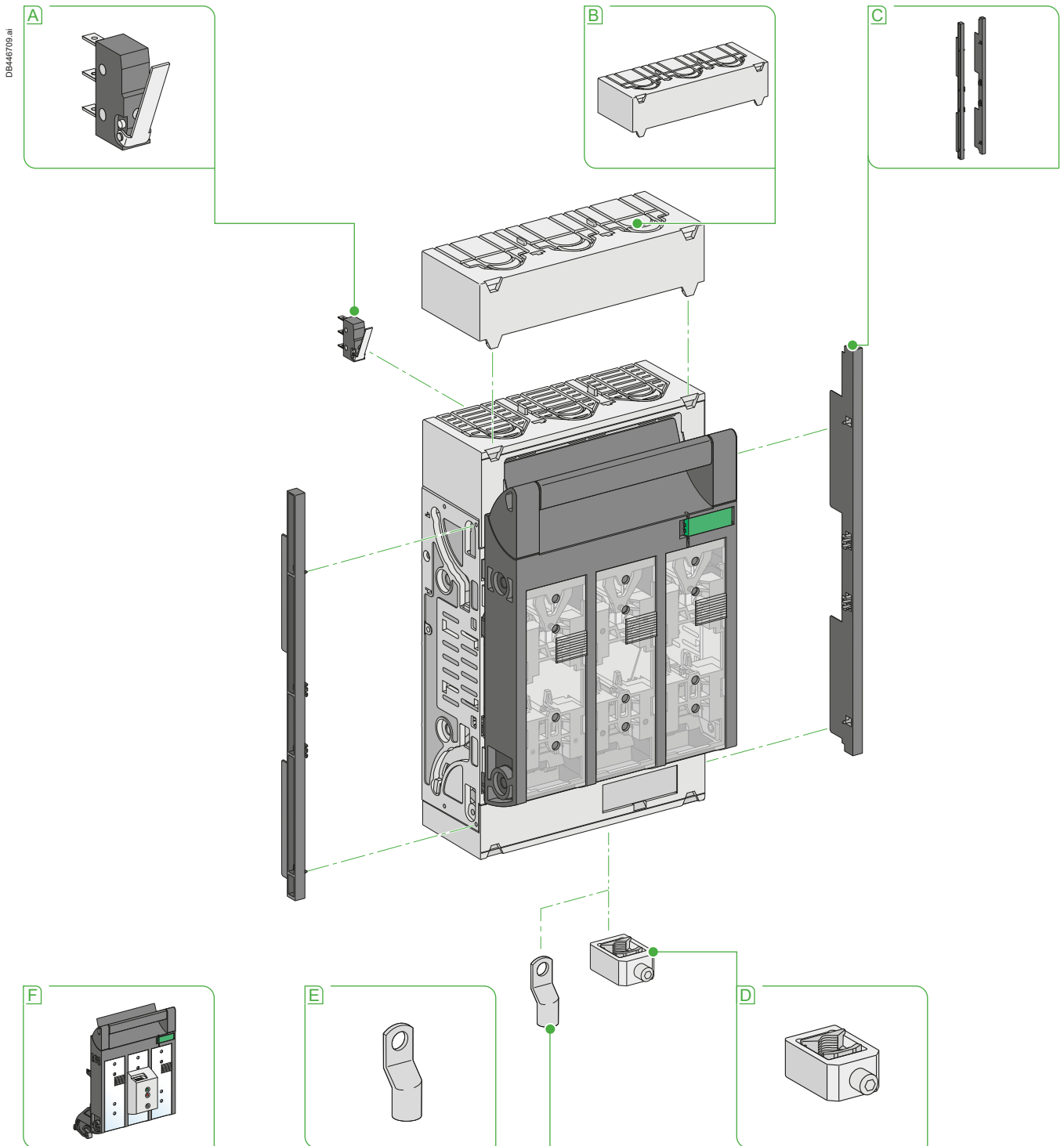

- A** NO + NC auxiliary changeover contacts
- B** Long terminal shield
- C** Laterally attachable support profile

- D** Connector for bare cable
- E** Lug for copper cable
- F** Fuse monitor

General characteristics: ISFT

FuPacT ISFT100N to ISFT630

A

PB115835.eps



PB115837.eps



PB117723_L54.eps



PB115845.eps



FuPacT ISFT offers innovative solutions

The FuPacT ISFT is a modern approach to power distribution with modular switchgear that is simple to install and reliable.

On the FuPacT ISFT the entire covers can easily be removed while the switching cover remains closed, thus eliminating the need for elaborate trim frames and extensions.

Integrated hand protection and a sliding viewing window enable voltage tests to be conducted on contact blades or strap handles. FuPacT ISFT offers two types of cable connection: cable lug or clamp connector for copper or aluminum conductors. All FuPacT ISFT can be sealed and fitted with a locking mechanism. FuPacT ISFT also provides a patented system of turnable hooks for converting the outgoing arrangement from top to bottom and vice versa. The fuse-switch-disconnectors can be attached, positioned and tightened effortlessly.

Smallest 100 A solution on market: ISFT100N

FuPacT ISFT offers two sizes for 100 A rating.

- Basic (without connection on busbar system), with a width of 106 mm.
- Narrow, which is the smallest 100 A solution on the market (connection on busbar system possible), with a width of 53 mm.

Objectives of this product is to reduced installation space and to propose two 100 A (106 mm width) replace one 160 A product (106 mm width also).

FuPacT ISFT for mounting on base plates

The disconnectors for mounting on base plates, sizes 000, 00, 1, 2 and 3, come with a number of predrilled fastening holes that allow these models to be used on base plates or on profiles. With the appropriate accessories, the sizes 000 and 00 can be mounted on DIN rail.

Accessories

Support Profile Laterally attachable

This accessory allows to enlarge the cut-out tolerances of the cover plates while also supporting these plates.

- Latchable bracket on the side.
- Allows greater cutting tolerances.

Switching cover position indicator:

- 1 close contact and 1 open contact.

Intelligent measurement

Electronic Fuse-Monitoring - Everything under control

Thanks to the electronic Fuse Monitor, technician could receive an information to localize a short circuit or overload. Maintenance will be more reactive to change fuse which is broken.

FuPacT ISFT range from size 00 to 3 has an electronic fuse monitor. The electronic fuse monitor is directly attached to the switching cover. This installation depth is 28 mm.

A light-emitting diode starts blinking red the moment the fuses fail. A test button and a 4-pole connector for remote indication are attached to the housing.

Note: for more technical informations, see [page A-22](#).

Functions and characteristics

General characteristics: ISFT

FuPacT ISFT100N to ISFT630

Safety

FuPacT ISFT provides:

- Protection against accidental contact in the standard model:
 - Terminal housing closed
 - Simple break-out for all versions
 - Terminal shield needed for specific application (> 500 V)
 - IP3X
 - Life part are covered.
- Switching with integrated and extended hand protection feature:
 - Prevents fuse-unit contact
 - Protection against electric arc.
- Voltage test thanks to independent slidable windows
- Snap-on busbar cover to protect against direct contact.
- Locking cover with sealing facility:
 - Locking mechanism for switching cover for non-instructed individuals
 - Switching cover is sealable.

Fast connection thanks to box terminals

For FuPacT 160 A size 00

- Advantageous box terminals:
 - Cu conductor from 2,5 to 95 mm²
 - No cable lug needed.
- Or universal screw terminal for M8 cable lug.

Options

- Prism clamp 6...70 mm² Cu/Al.
- Terminal 3 x 16 mm².

For FuPacT 250 to 630 A sizes 1–3

- The standard version:
 - Size 1 and 2 for M10 cable lug
 - Size 3 for M12 cable lug.
- Easy to change the various types of connection.

Options

- Prism clamp for Cu.
- Prism clamp for Cu/Al (1x cable).
- Prism clamp for Cu/Al (2x cables).

Turnable contact hooks

FuPacT ISFT is the first horizontal fuse switch-disconnector to propose turnable contacts hooks. This makes it easier to mount FuPacT ISFT on the busbar in addition to being more flexible. Due to its symmetry, FuPacT ISFT can be turned around at any time. Terminal top or bottom can be chosen freely. Thus, only one version needs to be stored.

- One universal solution for top or bottom cable outlet.
- Reduced stock.
- Universal to busbar thickness.
- More installation flexibility.



PB115840.eps

A



PB115841.eps

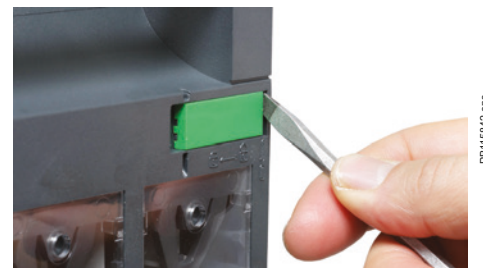

PB115842.eps

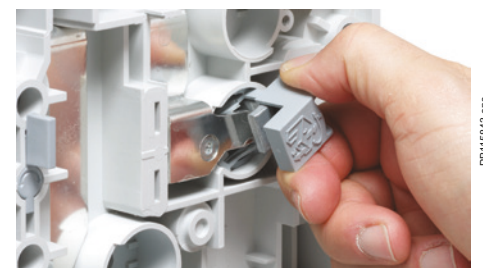

PB115843.eps

ISFT installation

FuPacT ISFT100N to ISFT630

ISFT fusegear is installed on a mounting plate, DIN rail or on busbars, depending on the power rating. Connections are made via cables or directly to the busbars via hook-on.

A

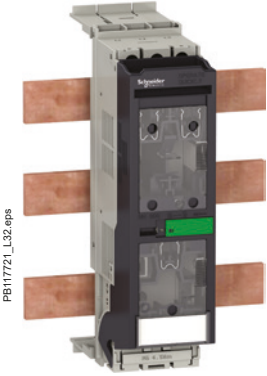

FB117721_L32.eps

ISFT100N (hook-on connection)

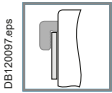

DB120057.eps

Hook-on connection to busbars: the device tightly hooks on to the busbars via three hooks that allows for both electrical connection and performant mechanical mounting. The connection systems can also be reversed to supply distribution circuits via the upstream terminals.

This system allows direct contact of the power circuit to the busbars (no cables, no bars, no drilling, etc.) and usual connections for downstream distribution (bare cable connectors, lugs, bars, distribution connectors, etc.).

ISFT100N fusegear

Installation on a mounting plate, on busbars 60 mm or DIN rail on busbars with:

- Cables or flexible bars
- Hook-on connection to 60 mm busbars.

Upstream or downstream connection of distribution circuits requires cables or flexible bars.

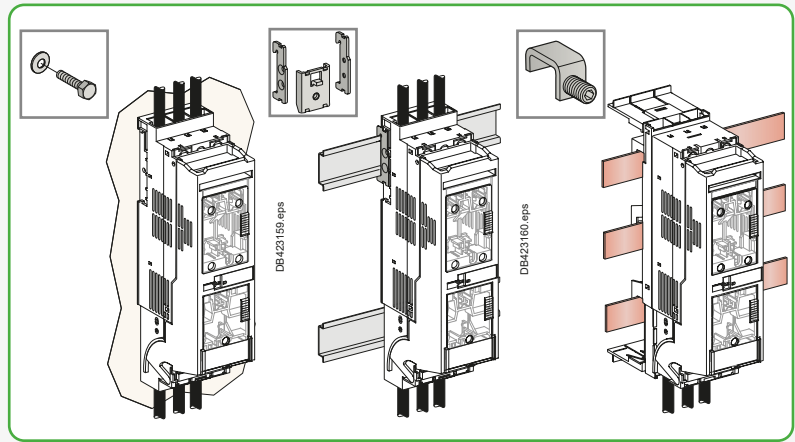

DB423158.eps

DB423159.eps

DB423160.eps

ISFT100 fusegear

Installation on a mounting plate or symmetrical DIN rail.

Power and distribution circuit connections require cables and built-in connectors.

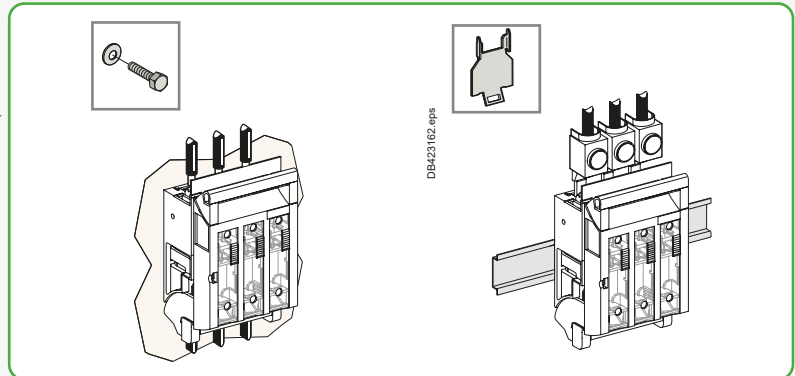

DB423161.eps

DB423162.eps

Functions and characteristics

ISFT installation

FuPacT ISFT100N to ISFT630

ISFT160 fusegear

Installation on a mounting plate or on busbars with:

- Cables or flexible bars
- Hook-on connection to 60 mm busbars

Downstream connection of distribution circuits requires cables or flexible bars.

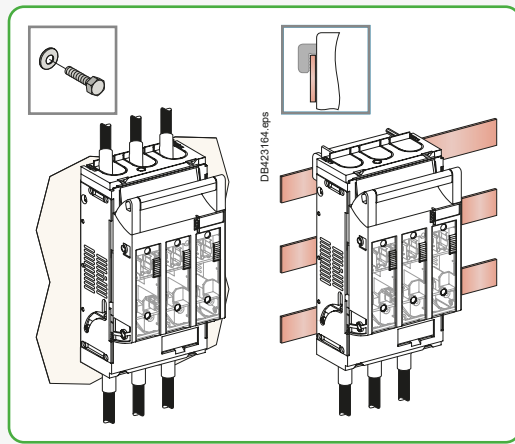

ISFT250 to ISFT630 fusegear

Installation on a mounting plate or on busbars with:

- Cables or flexible bars
- Hook-on connection to 60 mm busbars (except ISFT630)

Downstream connection of distribution circuits requires cables or flexible bars.

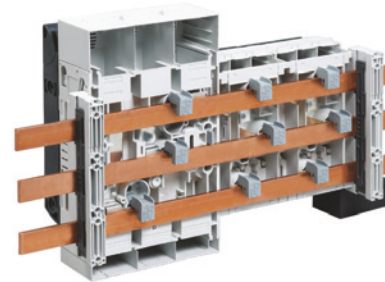
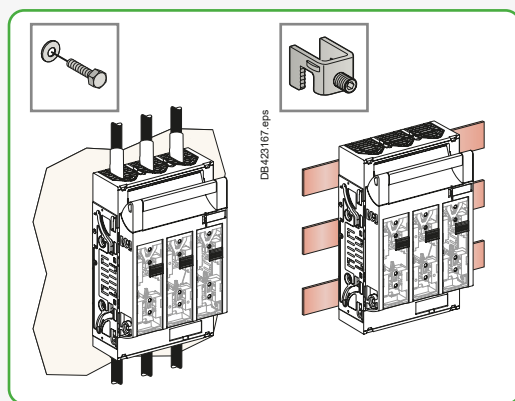

Hook-on connection (ISFT250 and 2 x ISFT160)

PB115844.eps



Connection and accessories

FuPacT ISFT100N to ISFT630 - Connection

FuPacT fuse-switch disconnectors can supply distribution circuits via either the upstream or downstream terminals. Devices intended for connection to busbars are configured as standard for distribution via the downstream terminals.

A

ISFT fusegear is equipped with connectors or terminals for front connection of:

- Bare cables for ISFT100N to ISFT160 devices
- Cables with lugs for ISFT160 to 630 devices
- Flexible bars for ISFT160 to 630 devices.

	ISFT100N	ISFT100	ISFT160	ISFT250	ISFT400	ISFT630
Cables						
Connector	2.5 to 50 mm ²	1.5 to 50 mm ²	-			
Lug to terminal	-	-	120 to 185 mm ²		120 to 300 mm ²	
Connector to terminal	-	-	2.5 to 95 mm ²	6 to 150 mm ²	6 to 240 mm ²	
box clamp re/se			6 to 50 mm ²	35 to 150 mm ²	95 to 300 mm ²	
m/sm			6 to 25 mm ²	50 to 150 mm ²	120 to 300 mm ²	
Pressure Plate						
Connector	-	-	6 to 70 mm ²	70 to 150 mm ²	120 to 240 mm ²	150 to 300 mm ²

ISFT100N fusegear

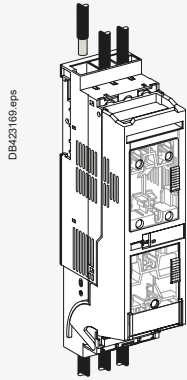

ISFT100 fusegear

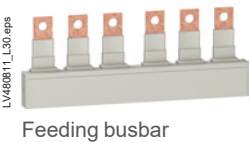
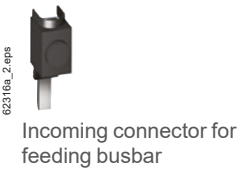
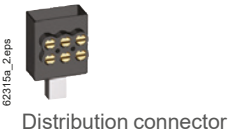
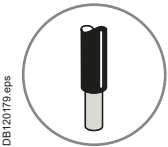
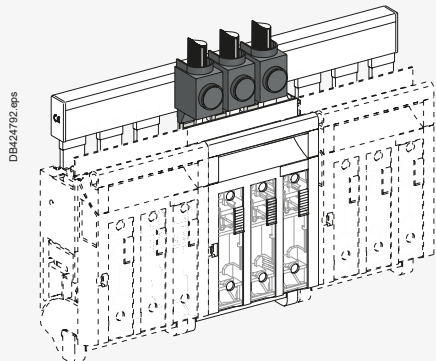
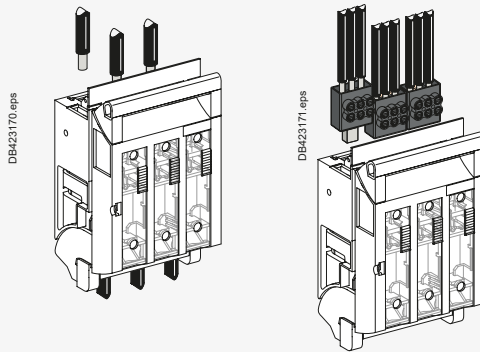

Connection and accessories FuPacT ISFT100N to ISFT630 - Connection

ISFT160 fusegear

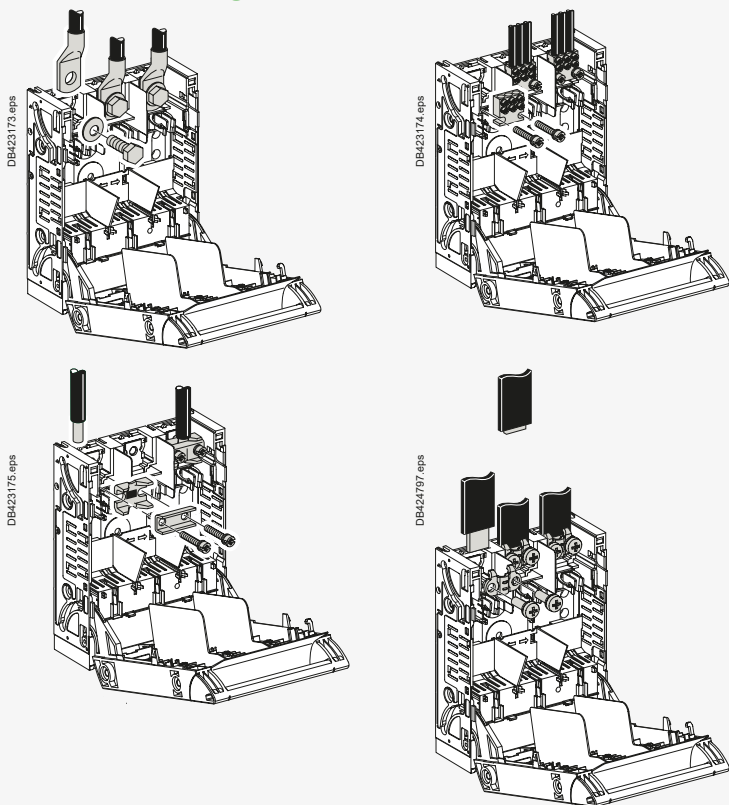

ISFT250/400/630 fusegear

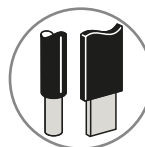
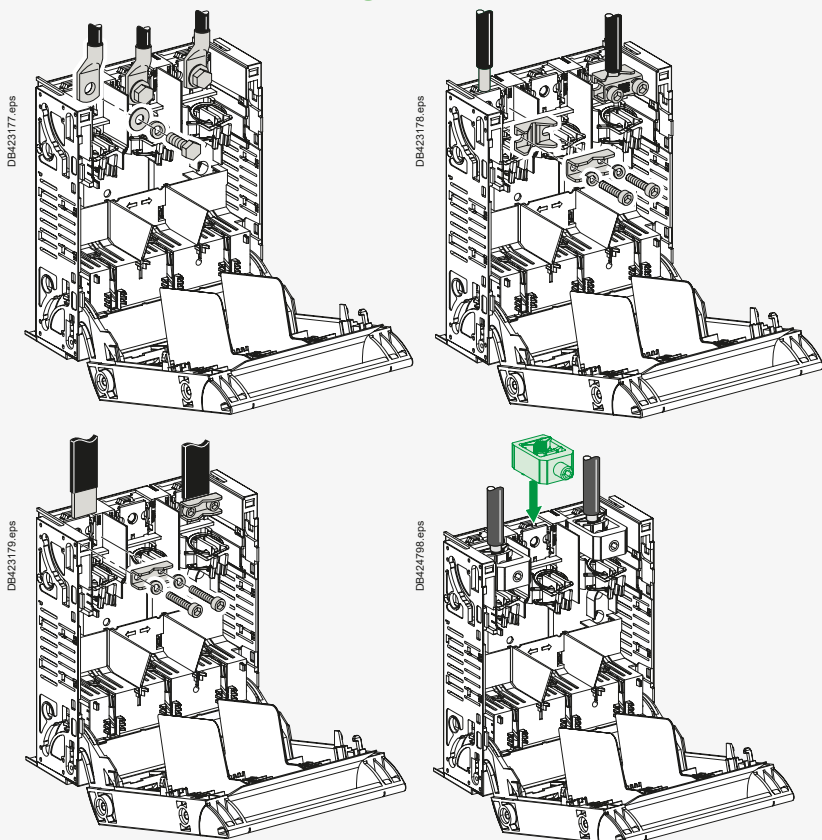

DB120162.eps



62330a_1-2_.eps

Lug for copper cables



LV480814_L17R.eps

Distribution connector



LV480816_L15.eps

Connector for bare Cu/Al cables



LV480815_L19.eps

Connector for flexible bars

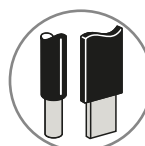

DB120162.eps



62330a_1-2_.eps

Lug for copper cables



LV480823_L19.eps

Connector for bare Cu/Al cables



LV480829_L22.eps

Connector for flexible bars



Connection and accessories

FuPacT ISFT160 to ISFT630 - Reverse distribution

FuPacT fuse-switch disconnectors designed for connection to busbars supply distribution circuits via the downstream terminals as standard. In the case of ISFT160 to ISFT630 devices, simple installation operations allow power to be supplied to the distribution circuits from upstream. In the case of ISFT100N devices, the method of distribution cannot be reversed simply by changing the direction of the mounting. There are separate references for each particular case.

A

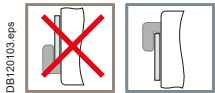

DB120103.eps

Hook-on connection: the orientation of the hooks on the busbars is always the same, whether the distribution circuits are connected to the upstream or downstream terminals. The fuse-switch disconnectors must physically hang on the busbars.



DB120104.eps

Symmetrical slots on the side of the base make it possible to raise and lower the cover that forms the fuse-carrier.

To reverse supply, depending on the model, simply turn 180°:

- Either the base with its connection kit
- Or the connection kit alone.

For fusegear with a fuse monitor, the fuse monitor cover must be changed given that different versions are used depending on whether supply is via the upstream or downstream terminals.

Operation to reverse supply (upstream/downstream terminals)

	180° rotation		Change Fuse monitor cover
	Base	Turnable hooks	
	 DB401353.eps	 DB401355.eps	 DB425101.eps
 ISFT160 to 400	yes	yes	yes
 ISFT630	yes	no	yes
 ISFT160	yes	-	yes
 ISFT250	yes	-	yes

Fusegear with hook-on connection

ISFT160/400

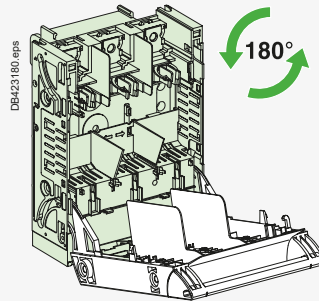

DB423160.eps

Turnable hooks

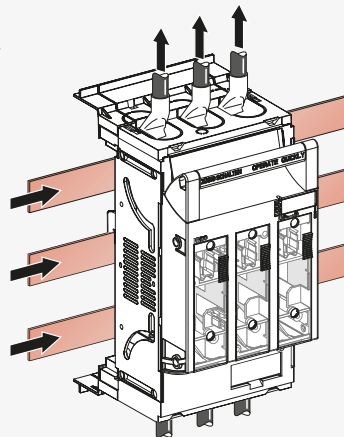

DB425096.eps

Connection and accessories

FuPacT ISFT100 and ISFT160 - Connection, coupling

It is possible to supply several ISFT100 and ISFT160 fusegears by using feeding busbars via a single incomer.

Supplying a several of devices via feeding busbars

Incoming connectors are used for the upstream power cables. Power is distributed to the other devices via feeding busbars or a combination of feeding busbars. Downstream connection of distribution circuits is done via cables.

ISFT100

2 devices

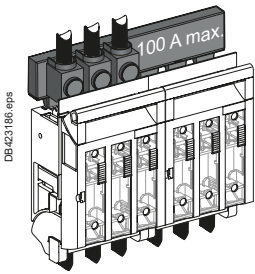

ISFT160

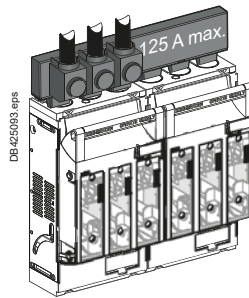

3 devices

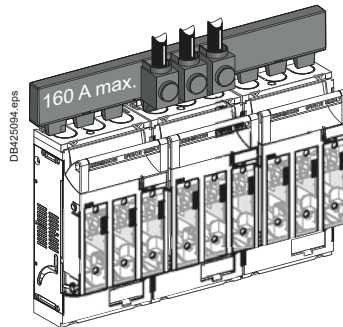
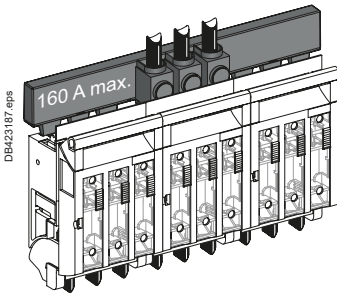

4 devices

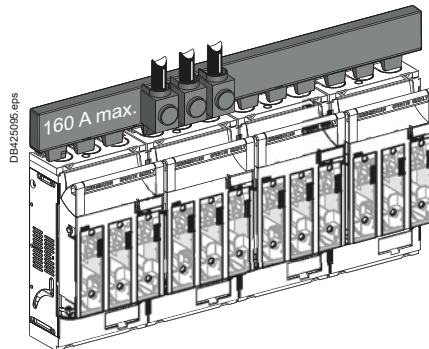
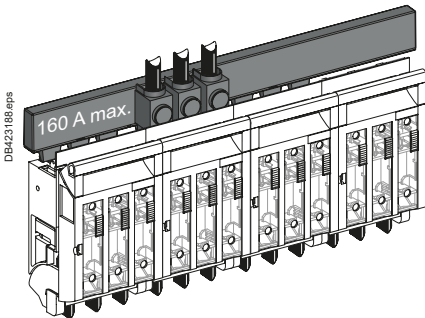

Combinations:

- 2 devices:
 - 1 incomer for 2 outgoing
- 3 devices ^[1]:
 - 1 incomer for 3 outgoing
- 4 devices ^[1]:
 - 1 incomer for 4 outgoing.

If the feed is connected at the center of the busbar, the total outgoing current of each busbar branch must not exceed the maximum busbar current per phase.

[1] For combinations of more than 2 ISFT100 devices, it is recommended to connect incoming power to the second device to reduce temperature rise.

Feeding busbars

Maximum operating voltage	690 VAC
Insulation coordination	overvoltage category III / pollution degree 2
Busbar cross-section	35 mm ²

The maximum current per phase when the feed is connected to a busbar extremity is 125 A. The maximum current per phase when the feed is connected at any busbar position is 160 A.



Connection and accessories

FuPacT ISFT100N, ISFT160 to ISFT400 - Different installation systems

A

Many connection and supply possibilities Supplying a set of busbars from an incoming device

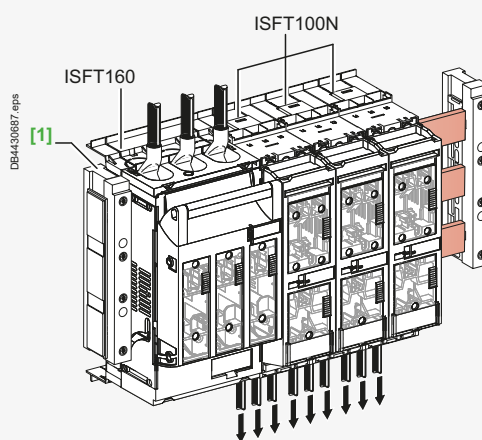
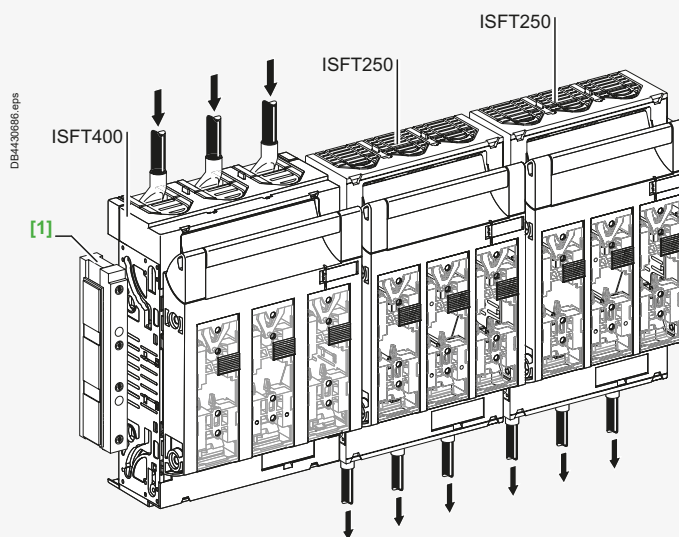

[1] Linergy BZ busbar system: for more technical informations, see [page D-6](#).

Connection and accessories

FuPacT ISFT100N, ISFT160 to ISFT400 - Different installation systems

Supplying a set of busbars from an incoming device

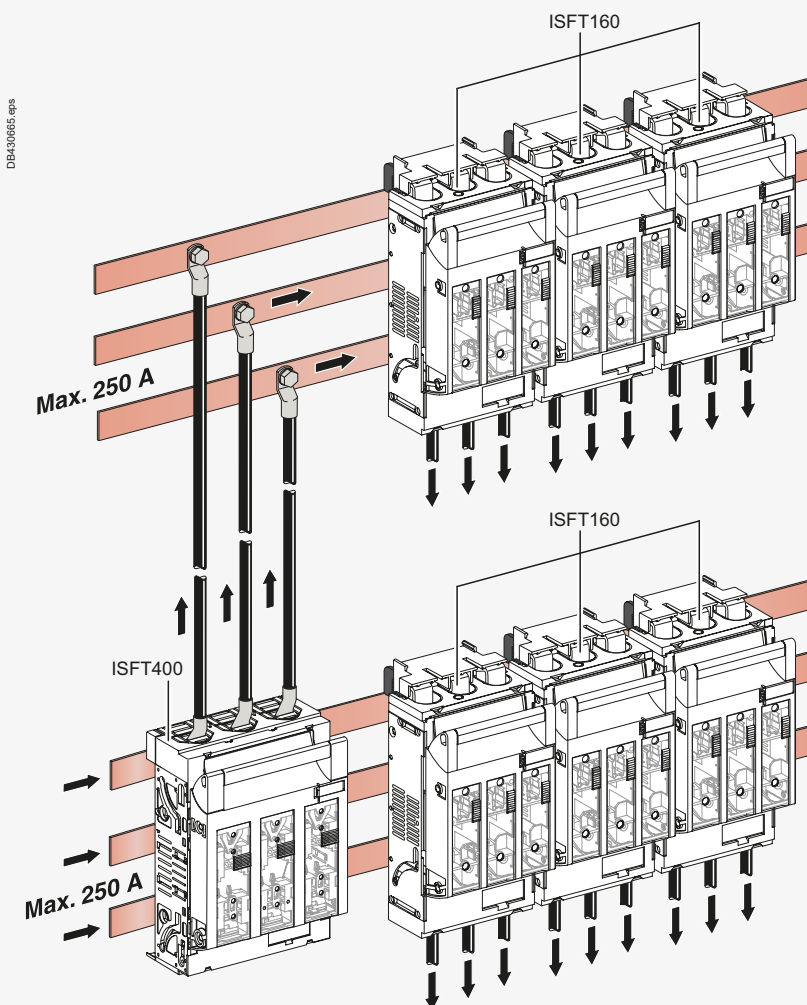
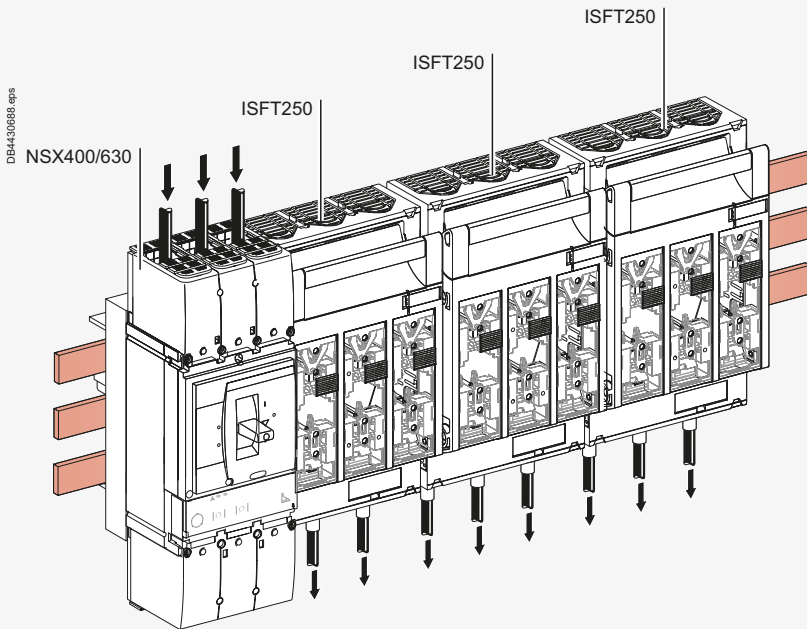

Fuse monitor

FuPacT ISFT160 to ISFT630

PE115845.eps



ISFT160 fuse monitor

A

Functions

This device provides remote indication of the status of standard fuses (without strikers). It is used to:

- Indicate a blown fuse
- Prevent the risks of abnormal voltages on the neutral
- It can only be used with $U < 690$ V AC.

Standards

- Compliance with international standard IEC 60947-5-1.
- Compliance with:
 - EN 50204
 - EN 61000 for electromagnetic compatibility (EMC).

Description

- Characteristics:
 - Operation with DIN fuses.
 - Degree of protection: IP20.
- May be used on capacitor bank circuits.
- Simplified power supply:
 - Does not require a specific power supply
 - Operates with unbalanced phases
 - Supplied via connection to the fuse terminals on the fusegear devices
 - Operational voltage: 400...690 V AC, $\pm 10\%$, 50/60 Hz.
- Tested for electromagnetic compatibility (EMC).
- Mounting:
 - Connected to the fuse-carrier assembly forming the cover.
- The package consists of:
 - A fuse-carrier/handle and fuse monitor sub-assembly supplied as a kit composed of:
 - Fuse monitor equipped with one NO contact and one NC contact
 - Fuse-carrier with the handle
 - The customer must remove his fuse-carrier/handle assembly from his product and replace it with this kit.
- Characteristics:
 - IP20 degree of protection
 - Product with fuse monitor must be integrated inside switchboards and not in front face in case of customers wants to have a complete class II insulation. Class II insulation with switchboard in front face is effective only when FuPacT ISFT is in closed position and with a door or a protection behind the fuse monitor.

Operation

Reset

The device is automatically reset when the fuse-links are replaced.

Indications

- Normal operation:
 - The green LED is ON when voltage is present at the fuse terminals
 - The contacts are in the rest position.
- Operation when a fuse blows:
 - The green LED goes off and the red LED goes on
 - The contacts are actuated:
 - The NO contact is for remote fault indication
 - The NC contact may be used, for example, to control an undervoltage device in order to shut down equipment that may be sensitive to single-phasing.

> FuPacT ISFT160 to 630 fuse monitor
Instruction sheet



NVE88766

Electrical characteristics

Power circuit

Rated operational voltage	400 to 690 V AC 50/60 Hz $\pm 10\%$
Consumption	< 3 VA
Rated frequency	50/60 Hz
Measurement impedance	> 1000 Ω/V
Rated impulse withstand voltage (1.2 / 50 μs)	8 kV

Auxiliary contact output terminals

Terminal indications	NO	13 - 14
	NC	21 - 22
Cable capacity	Flexible	$\leq 1.5 \text{ mm}^2 \text{ Cu}$
	Rigid	$\leq 2.5 \text{ mm}^2 \text{ Cu}$

Output contact characteristics (1NO + 1NC)

Conventional thermal current I _{th} (A)	5
Rated insulation voltage (V)	250
Minimum load	10 mA at 24 V

Characteristics

Utilisation category (IEC 60947-5-1)		AC		DC	
		AC12	AC15	DC12	DC13
Operational current (A)	24 V	-	3	-	2
	48 V	-	3	-	-
	110 V	-	3	-	-
	220/240 V	-	3	-	-
	250 V	-	3	-	-
	380/415 V	-	-	-	-
	440 V	-	-	-	-
660/690 V	-	-	-	-	
Rated operational voltage / max. breaking voltage (V AC)		250/440			
Breaking capacity (VA)		2000			

General characteristics

Operating temperature range (°C)	-25...+55 ($\leq 500 \text{ V}$)	-25...+45 ($> 500 \text{ V}$)
Storage and transport temperature range (°C)	-40...+70	
Fuse blowing detection time (s)	< 2	
Overvoltage category / degree of pollution	IEC 60947-1 3	
Dielectric test voltage (between power circuit and output terminals)	5 kV rms / 1 min 50 Hz	

Electromagnetic compatibility - emission

Conducted	EN 55022 Class B
Radiated	EN 55022 Class B
Harmonic currents	EN 61000-3-2 Class A

Electromagnetic compatibility - immunity

Electrostatic discharge (ESD)	EN 61000-4-2 category B level 2/3
Radiated field susceptibility (RF)	EN 61000-4-3 category A level 3
Surge immunity test	EN 61000-4-5 level 4
Conducted low energy susceptibility (EFT)	EN 61000-4-4 category B level 3
Conducted high energy susceptibility (RF)	EN 61000-4-6 category A level 3
Radio-frequency interference (GSM)	ENV 50204 category A

Magnetic field immunity

Continuous	EN 61000-4-8 level 5
------------	----------------------

Mechanical characteristics

Degree of protection	IP20
Weight (fuse monitor alone) (kg)	0.2
Dimensions	

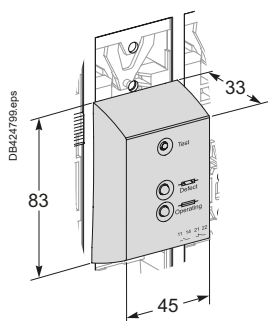

Insulation

FuPacT ISFT100N to ISFT630



Some accessories for insulation are used to prevent direct contact with the main circuits. For ISFT100, we have single and double escutcheon (with 1 free slot). These escutcheons, which could be used in combination, allow one type of cut-out on the front panel of switchboard. But in case of feeding busbars, The use of escutcheon is not compliant with feeding busbars. For ISFT100N and ISFT160 to 630, side profiles (or laterally attachable) provide vertical IP level across the door. The switchboard manufacturer must provide the horizontal IP. For those products, it's mandatory to use terminal shield when voltage is upper or equal to 500 V.

A

Insulation of live parts

Escutcheon

Clipped on the device, escutcheons provide IP20 and IK07 degrees of protection.

Type	Escutcheon type			Terminal shield
				
ISFT100N	●	-	-	●
ISFT100	-	●	●	-
ISFT160	●			●
ISFT250	●			●
ISFT400	●			●
ISFT630	●			●

ISFT100N fusegear - Terminal shield and escutcheon

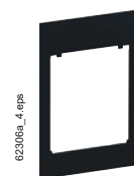
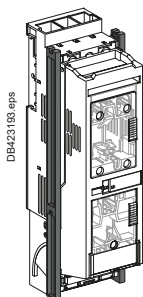
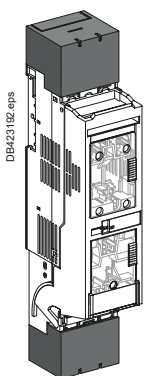

Escutcheon



Terminal shields

ISFT100 fusegear - Escutcheon

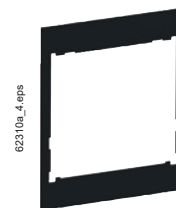
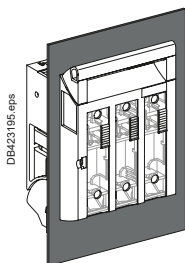

Escutcheon

ISFT160 to ISFT630 fusegear - Terminal shields and escutcheon

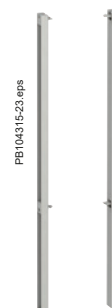
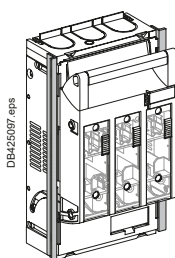
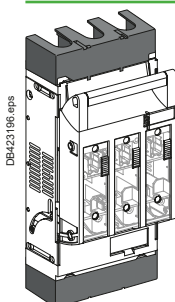

Laterally attachable support profile

Functions and characteristics

Fuse-link monitoring and testing

FuPacT ISFT160 to ISFT630

Monitoring

ISFT 160 to 630 fuse-switch disconnectors are equipped with independent large windows so that the fuse-link technical characteristics are clearly visible.

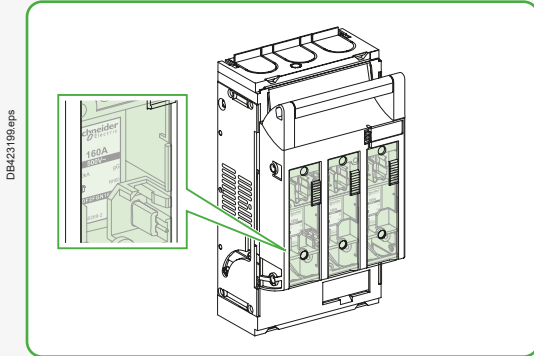

DB423199.eps

Testing

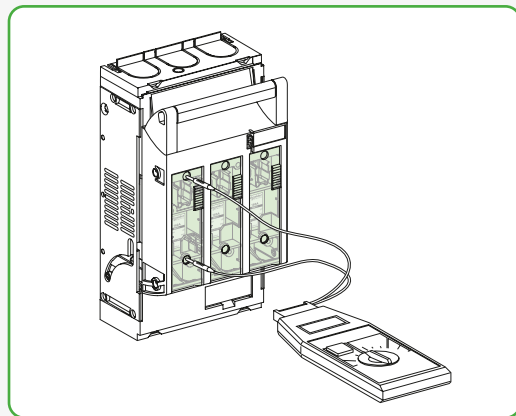

DB423200.eps

Independent sliding covers on the front panel provide access to the fuse-link status test points while maintaining the IP20 protection index.



PB115839.eps

ISFT160



PB115846.eps



Control, locking and operation

FuPacT ISFT100N to ISFT630

The main moving contacts are controlled by the pivoting fuse-carrier assembly forming the cover for the ISFT devices. In open position, the fuse-switch disconnecter fuse-carrier assembly provides isolation with visible break.

A

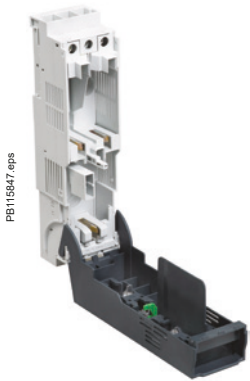

ISFT100N.

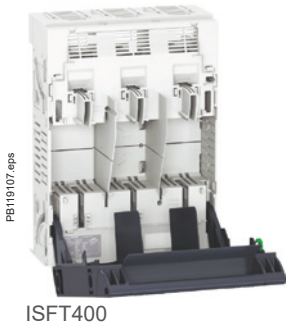

ISFT400

Access to the fuse-links:

- May be provided by lead seals on the ISFT devices

To lock the fuse-switch disconnecter in closed (ON) position, the fuse-carrier is equipped as standard with a locking part.

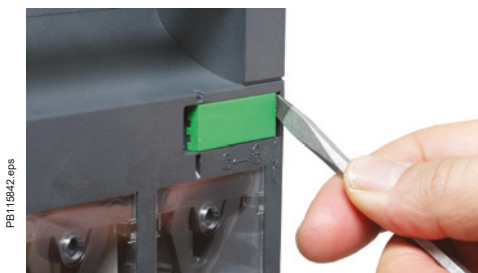

Control

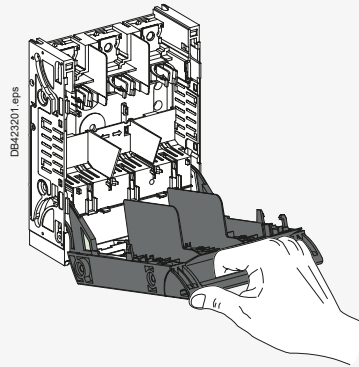

Locking

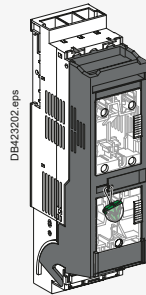

Lead-seal locking for the ISFT100N

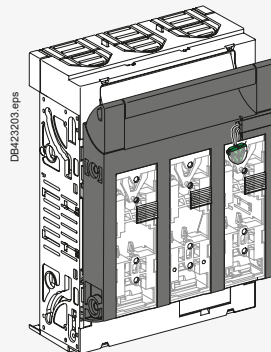

Lead-seal locking for the ISFT100 to ISFT630 devices

Locking in open (OFF) position isolation as defined by IEC 60947-3.

Type	Function	Means	Accessory
ISFT100N	Device locking in closed (ON) position	Lead seal	Built-in
ISFT100			
ISFT160			
ISFT250 to ISFT630			

Functions and characteristics

Control, locking and operation

FuPacT ISFT100N to ISFT630

- For ISFT fusegear devices, the fuse-carrier cover is used both to control the device and to protect the fuse-link.
- ISFT100N: the pivoting fuse-carrier assembly accepts two fuse-links side by side and a third situated under the first two fuse-links.
 - ISFT100 to ISFT630: the pivoting fuse-carrier assembly accepts the three fuse-links side by side.

Fuse-carriers

Compatibility between ISFT fuse-switch disconnectors and fuse-links (NH)

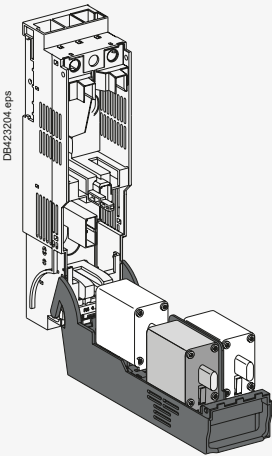

Pivoting fuse-carrier assembly for the ISFT100N

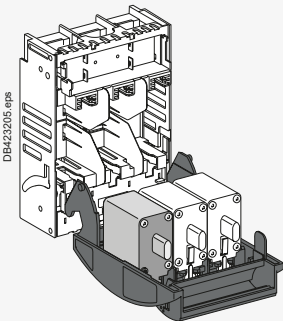

Pivoting fuse-carrier assembly for the ISFT100 to ISFT630 devices

Type of DIN fuse-link	NH000	NH00	NH1	NH2	NH3
ISFT100N	●	-	-	-	-
ISFT100	●	-	-	-	-
ISFT160	-	●	-	-	-
ISFT250	-	-	●	-	-
ISFT400	-	-	-	●	-
ISFT630	-	-	-	-	●

Insertion and removal of fuse-links

Fuse-links are held in place by clips behind the front panel of the fuse-carriers, thus making removal possible without touching the fuse-links.



Auxiliary contacts and indications

FuPacT ISFT100N to ISFT630



The optional auxiliary contacts carry out indication functions. They provide remote indication of the fuse-switch disconnecter status. They may also be used to indicate and carry out automatic functions such as electrical interlocking.

Standards: compliance with international recommendation IEC60947-5-1.
Description: NC/NO changeover contact.

Functional table of contact status

Auxiliary changeover contact		
		Maximum number
ISFT100N		1
ISFT100		2
ISFT160		2
ISFT250		2
ISFT400		2
ISFT630		2

Auxiliary changeover contact for ISFT100N and ISFT160

Conventional thermal current I _{th} (A)		2			
Rated insulation voltage (V)		250			
Minimum load		100 mA at 24 V			
		AC		DC	
Load		AC12	AC15	DC12	DC13
Rated operational current (A)	24 V	6	-	3	-
	48 V	6	-	1	-
	110 V	6	-	0.5	-
	220/240 V	6	-	0.25	-

Auxiliary changeover contact for ISFT100 and ISFT250 to 630

Conventional thermal current I _{th} (A)		2			
Rated insulation voltage (V)		250			
Minimum load		100 mA at 24 V			
		AC		DC	
Load		AC12	AC15	DC12	DC13
Rated operational current (A)	24 V	2	-	0.2	-
	48 V	2	-	0.2	-
	110 V	2	-	0.2	-
	220/240 V	2	-	0.2	-

Functions and characteristics

Auxiliary contacts and indications

FuPacT ISFT100N to ISFT630

Position of auxiliary contacts for ISFT devices

ISFT100N

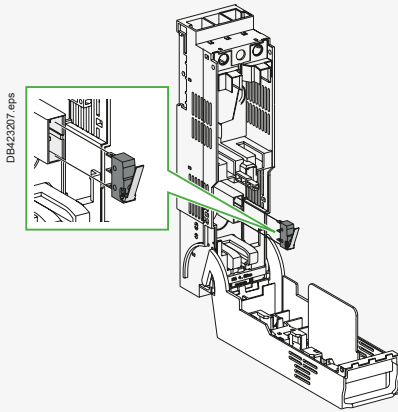

ISFT100

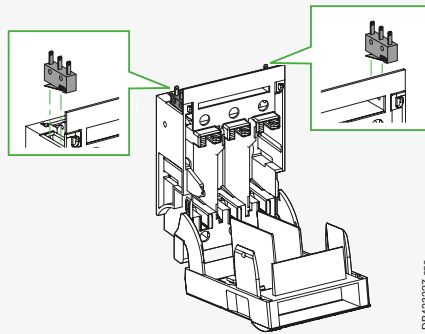

ISFT160

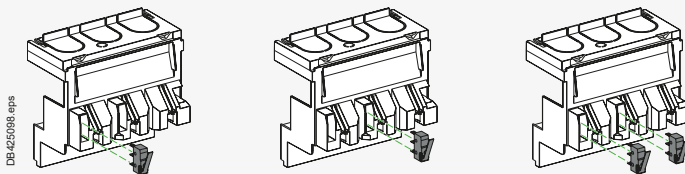

ISFT250/400/630

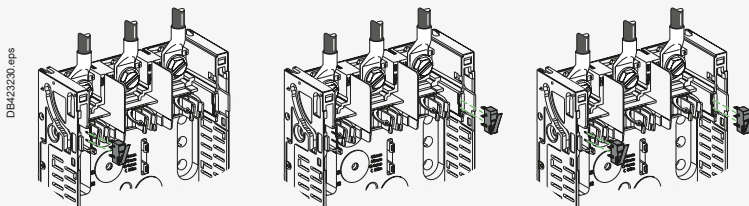

DB42327.eps

LV448041_image.eps

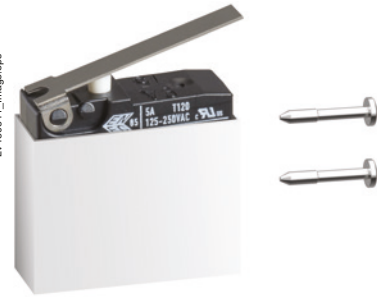

Possible installation positions and mounting

FuPacT ISFT100N to ISFT630

A

Possible installation positions

ISFT100N to ISFT630

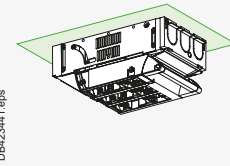
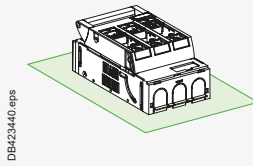
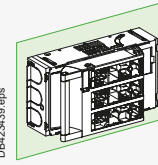
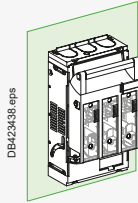

Possible mounting

ISFT100N and ISFT100

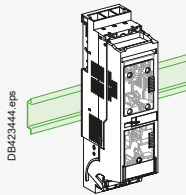

DIN rail

ISFT100N to ISFT630

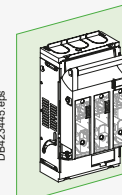

Plain mounting plate

ISFT100N ISF●160 to ISF●630 ISFL1250

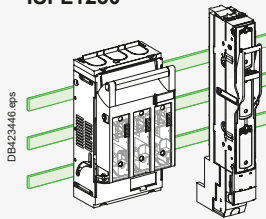

Secured to busbars

ISFT100N to ISFT630

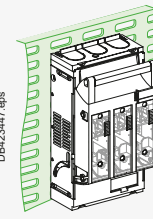

Slotted mounting plate



Reverse supply

FuPacT fusegear may be supplied equally well via the upstream or downstream terminals, without any reduction in performance.

Conductor materials and electrodynamic forces

FuPacT fusegear may be connected using either bare copper, tinned copper or tinned aluminium conductors (flexible or rigid bars, cables).
 In the event of a short-circuit, thermal and electrodynamic forces are exerted on the conductors. The conductors must therefore be adequately sized and suitably supported.
 Note that the terminals of electrical devices (switch-disconnectors, contactors, circuit breakers, etc.) should not be considered to contribute to the support of the conductors.

Cable ties and flexible bars

The table below indicates the maximum distances between cable ties depending on the prospective short-circuit current.
 Care must be taken not to exceed a distance of 400 mm between ties mechanically fixed to the switchboard frame.

Type of tie	"Panduit" type			"Sarel" type				
	Width: 4.5 mm			Width: 9 mm				
	Max. load: 22 kg			Max. load: 90 kg				
	Color: white			Color: black				
Max. distance between ties (mm)	200	100	50	350	200	100	70	50 (double ties)
Short-circuit current (kA rms)	10	15	20	20	27	35	45	100

Note: for cables $\geq 50 \text{ mm}^2$, 9 mm wide ties must be used.

Tightening torque for ISFT with screw connection

	Type	Torque (Nm)
ISFT	ISFT100N mounted on backplate with connection terminals	4.5
	ISFT100N with hook-on connection to 60 mm busbars	4.5
	ISFT100 mounted on backplate with connection terminals	3
	ISFT160 mounted on backplate with connection terminals	12
	ISFT160 with hook-on connection to 60 mm busbars	12
	ISFT250 mounted on backplate with connection terminals	20
	ISFT250 with hook-on connection to 60 mm busbars	20
	ISFT400 mounted on backplate with connection terminals	20
	ISFT400 with hook-on connection to 60 mm busbars	20
	ISFT630 mounted on backplate with connection terminals	20

Implementation and power dissipation

FuPacT ISFT

Power dissipated by ISFT fuse-switch disconnectors

Power dissipated per pole

	Rating (A)	Switchgear		Fuse-link Max. power dissipated		Total Total power dissipated per pole (W)	
		Model	Power dissipated per pole (W)	Rat. (A)	P (W)		
Fixed front-connected device (without conversion kit)	100	ISFT100N	3.3	100	7.5	11	
	100	ISFT100	3.6	100	7.5	11	
	160	ISFT100	3.8	160	8.2	12	
	160	ISFT160	3.0	160	12	15	
	250	ISFT 250	6	250	23	29	
	400	ISFT400	10	400	34	44	
With conversion kit	630	ISFT630	19	630	48	67	
	60 mm hook-on connection	100	ISFT100N	3.7	100	7.5	11
	60 mm hook-on connection	160	ISFT160	5.6	160	12	17
	60 mm hook-on connection	250	ISFT250	6.7	250	23	30
	60 mm hook-on connection	400	ISFT400	5.3	400	34	46



Dimensions and connection

FuPacT ISFT100N

Dimensions and mounting

Dimensions

Device to be installed on a backplate or DIN rail

Fuse-carrier closed

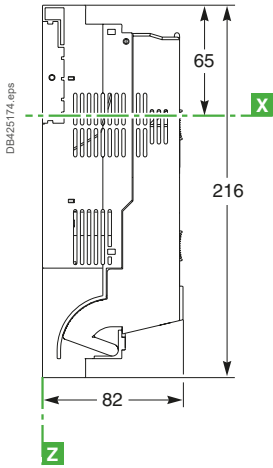

Front

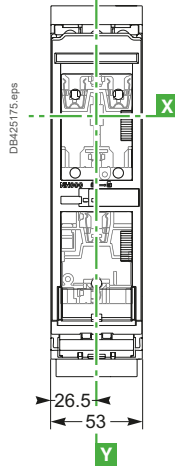

Fuse-carrier open

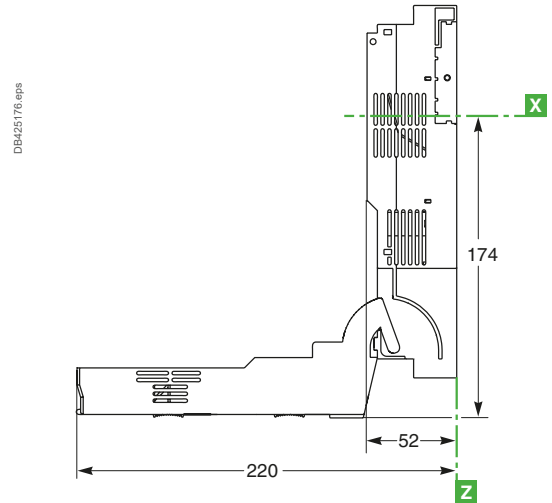

Device to be installed on a busbar

Fuse-carrier closed

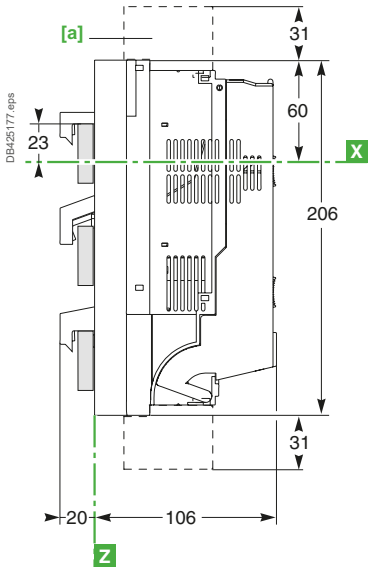

Front

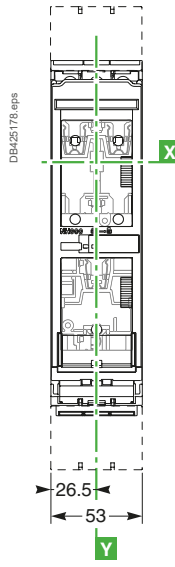

Fuse-carrier open

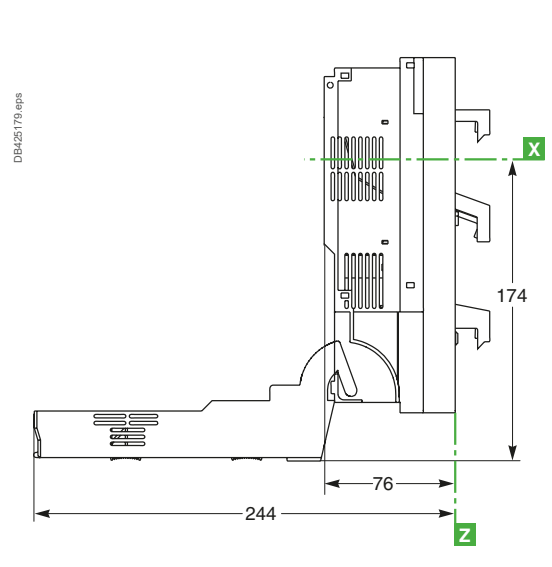

[a] Terminal shields.

Mounting

On backplate

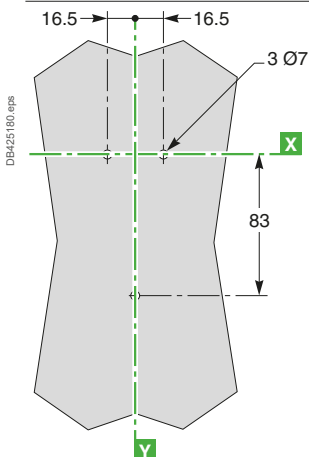

On DIN rail

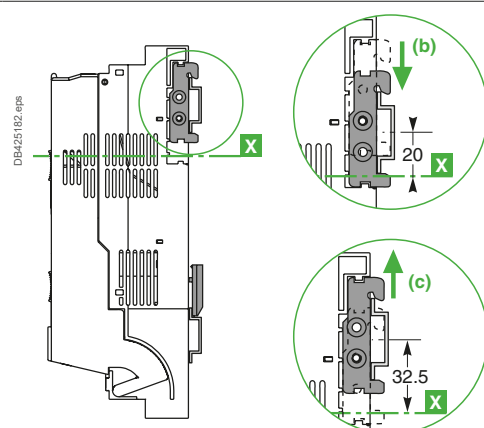
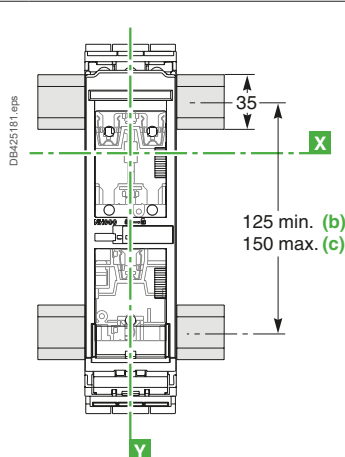

FuPacT ISFT100N

Front panel cut-outs - Connection and accessories

Mounting (cont.)

On 60 mm busbars

A

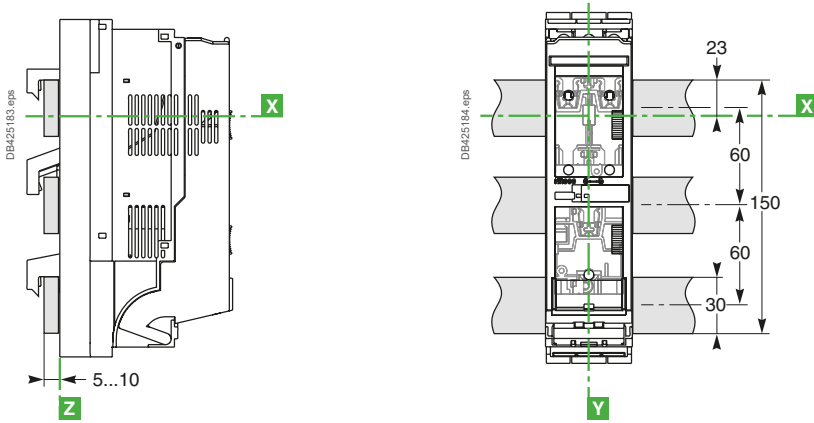

Front panel cut-outs

Device to be installed on a backplate or DIN rail

Cut-out for 1 device [1]

Cut-out for 2 devices [2]

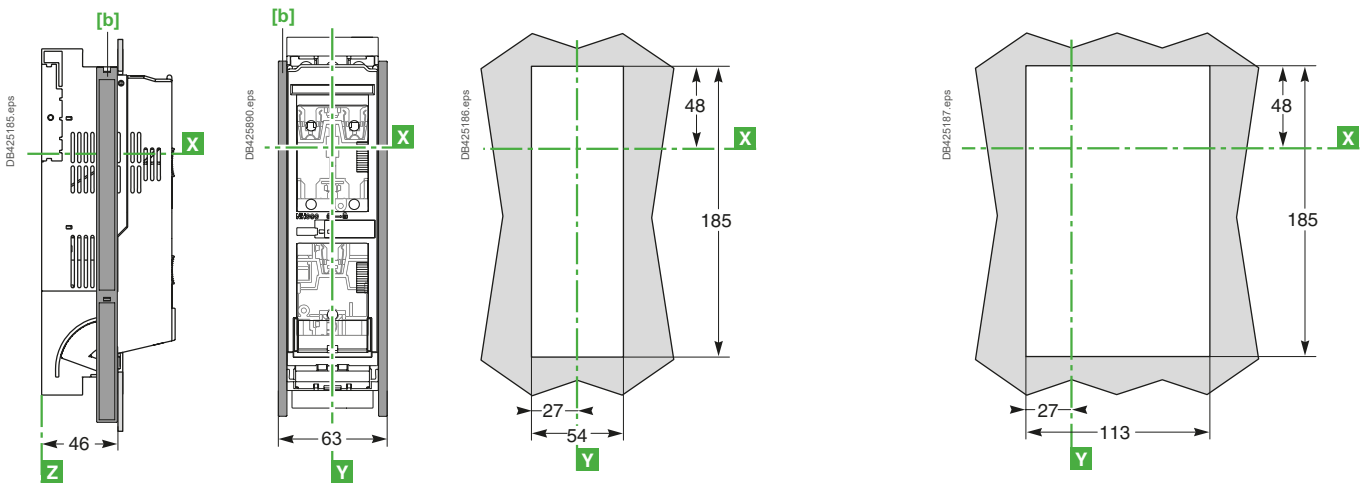

[1] With or without side profile, see page A-24. - [2] With side profile, see page A-24. -

Device to be installed on a busbar

Cut-out (c) for 1 device

Cut-out (d) for 1 device

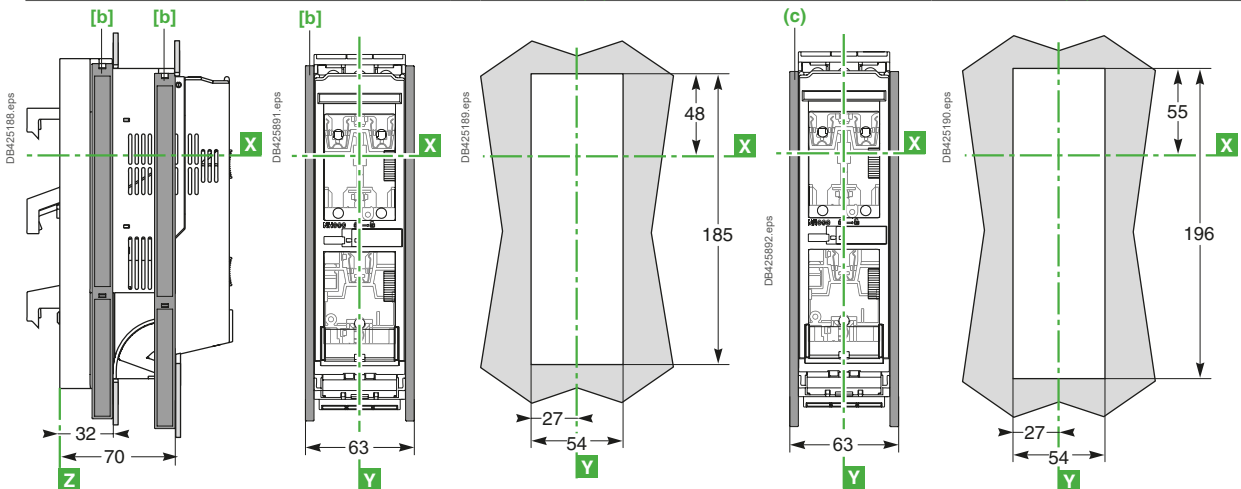

Front connection of cables

FuPacT ISFT100N devices are equipped as standard with connectors for bare copper cables from 2.5 to 50 mm² for mounting on backplates.

Standard device

	FuPacT connectors L (mm)	18
	S (mm ²)	2.5 to 50 rigid
	Cu/Al	2.5 to 35 flexible
	Torque (Nm)	3

[b] Laterally attachable support profile.

Dimensions

Device to be installed on a backplate or DIN rail

Fuse-carrier closed

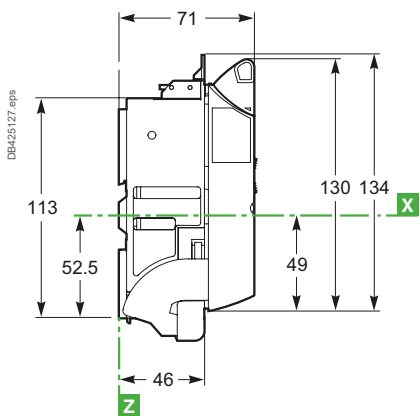

Front

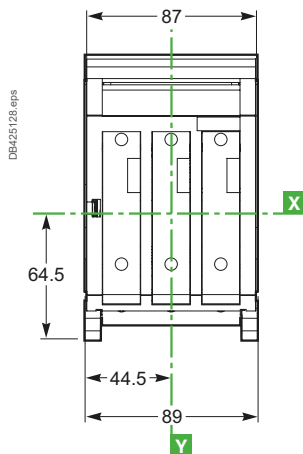

Fuse-carrier open

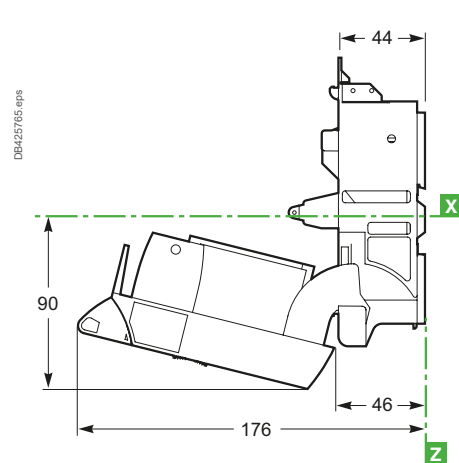

Feeding busbar for 2 ISFT100 devices

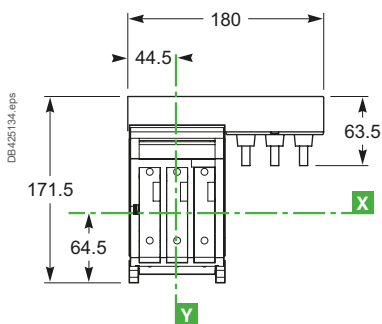

Feeding busbar for 3 ISFT100 devices

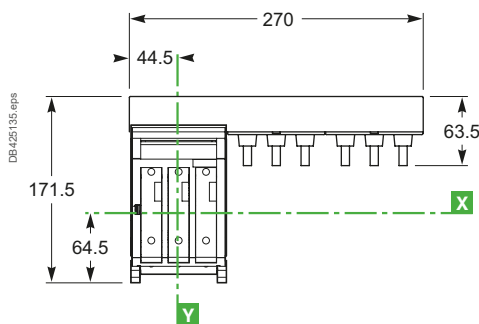

Feeding busbar for 4 ISFT100 devices

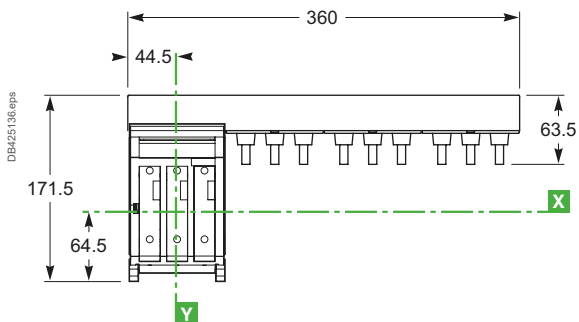

FuPacT ISFT100

Mounting and front panel cut-outs

Mounting

On backplate

On a symmetrical DIN rail

A

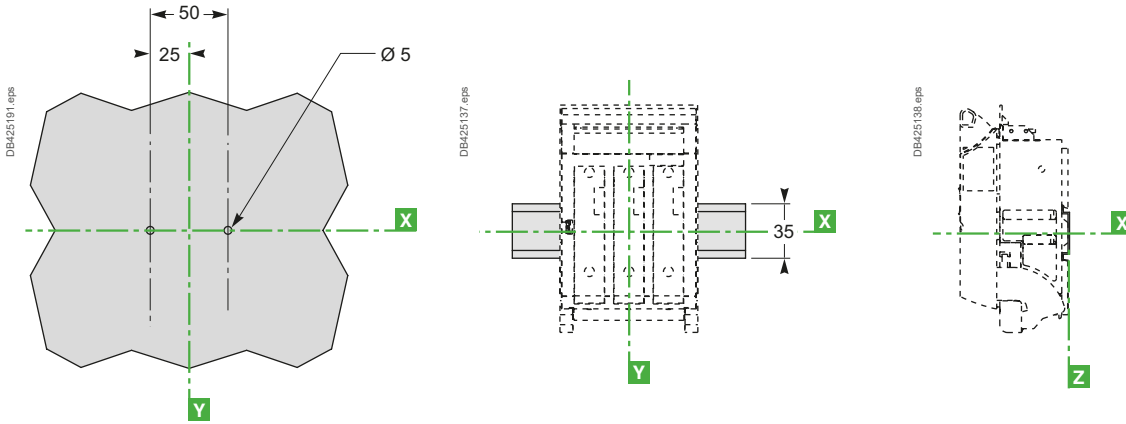

Front panel cut-outs

Cut-out for 1 device

Cut-out for 2 devices

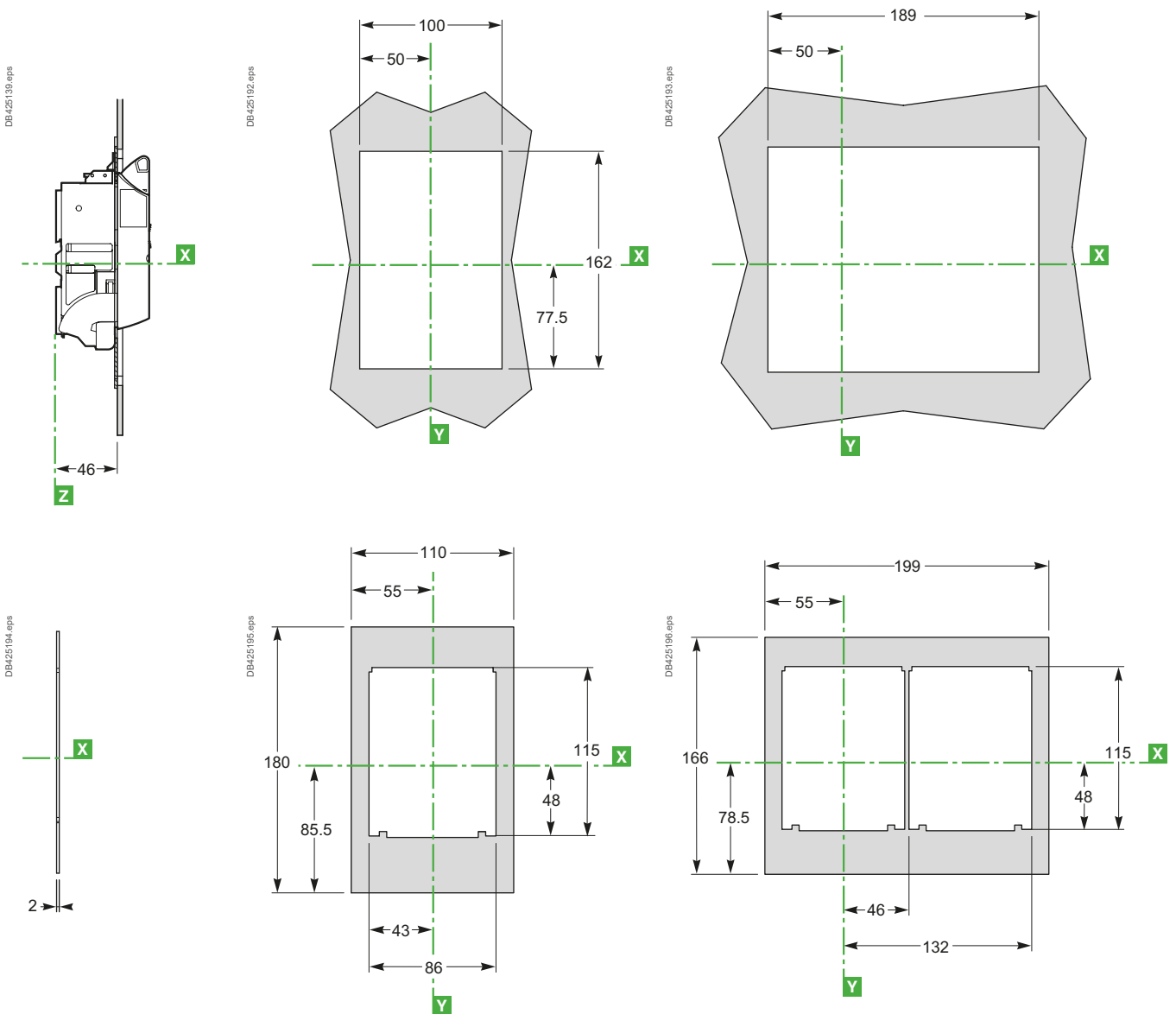

Dimensions and connection

FuPacT ISFT100

Connection and accessories

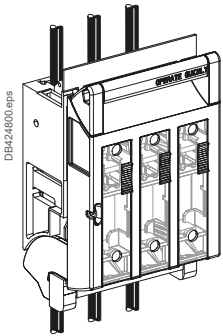

Connection via bare cable connectors

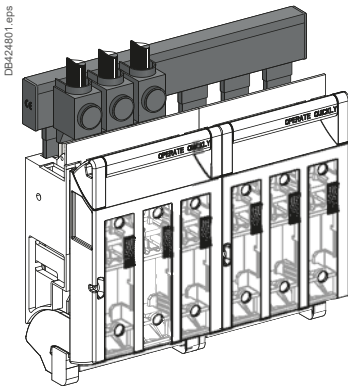

Connection via feeding busbars

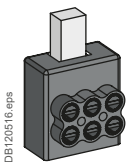

Distribution connector

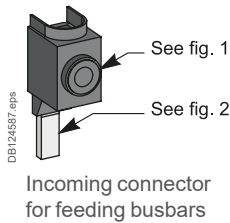

Incoming connector for feeding busbars

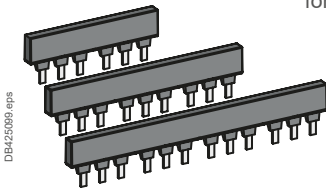

Feeding busbars

Front connection via bare cable connectors

FuPacT ISFT100 devices are equipped as standard with connectors for bare copper or aluminium cables from 1.5 to 50 mm² for mounting on backplates.

Standard device

FuPacT connectors	L (mm)	18
	S (mm ²)	1.5 to 50 rigid
	Cu/Al	1.5 to 35 flexible [1]
	Torque (Nm)	3



3 x 10 mm² distribution connector

FuPacT connectors	L (mm)	18
	S (mm ²)	1.5 to 10 rigid
	Cu/Al	1.5 to 6 flexible [1]
	Torque (Nm)	2 (cables) 3 (connectors)

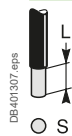

[1] Connection of 2.5 to 4 mm² flexible cables requires crimped or auto-crimping ferrules.

Front connection via feeding busbars

This accessory simplifies connection of cables and can be used to supply two to four FuPacT ISFT100 devices.

- Tightening torque 3 Nm.

Incoming connector for feeding busbars

FuPacT connectors	L (mm)	18
	S (mm ²)	25 to 95 rigid
	Cu/Al	25 to 70 flexible
	Torque (Nm)	10 (cables) 3 (connectors)

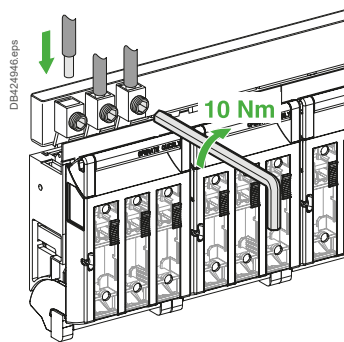
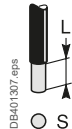

Figure 1

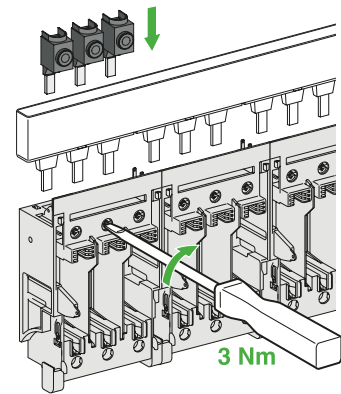

Figure 2

Busbar Usage Recommendation

			60 mm	100 mm	185 mm	185mm Sidewise/Coupling
ISFT	ISFT100N/DIN 000 3P Mounting Backplate	LV480750	-	-	-	-
	ISFT100N/DIN 000 3P Hook-on 60 mm Busbar - Upstream distribution	LV480751	●	-	-	-
	ISFT100N/DIN 000 3P Hook-on 60 mm Busbar - Downstream distribution	LV480752	●	-	-	-
	ISFT100 3P Fixed Front Connected	LV480800	-	-	-	-

FuPacT ISFT100

Connection and accessories

Basic device with distribution connector option

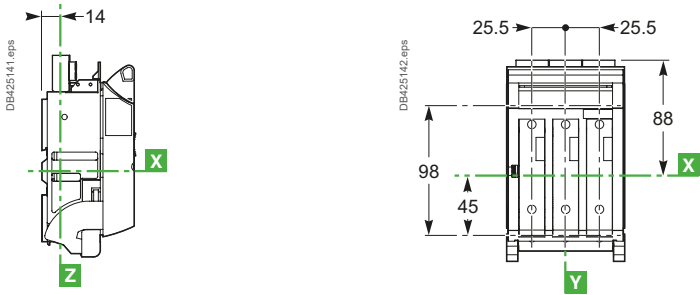

Feeding busbars for two or three ISFT100 devices (with 25 to 95 mm² incoming connector)

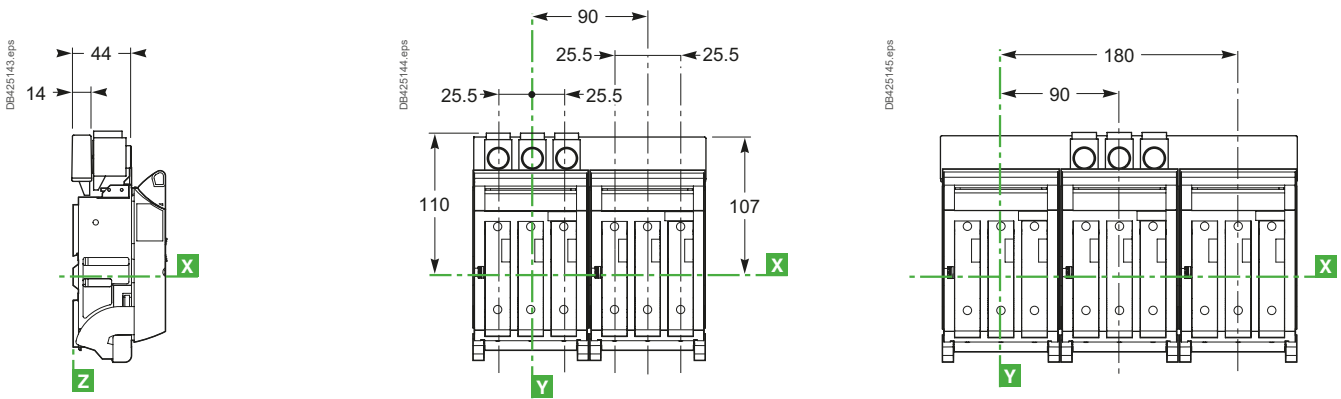

Feeding busbars for four ISFT100 devices (with 25 to 95 mm² incoming connector)

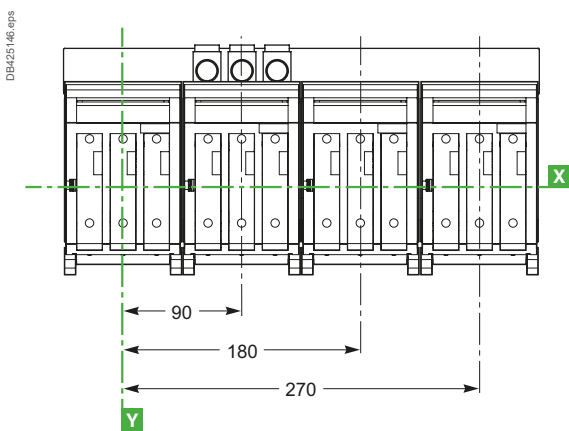

Dimensions

Fuse-carrier closed

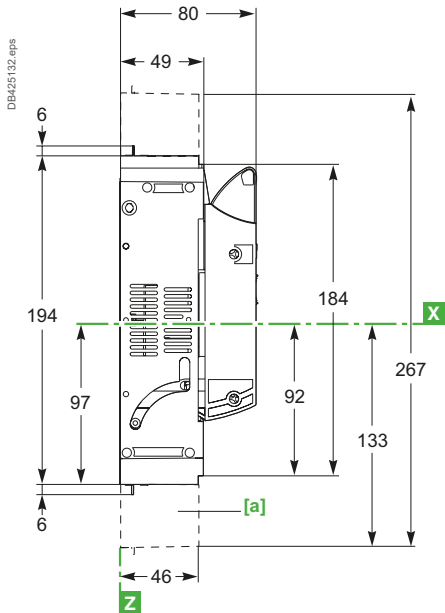

[a] Terminal shields.

Front

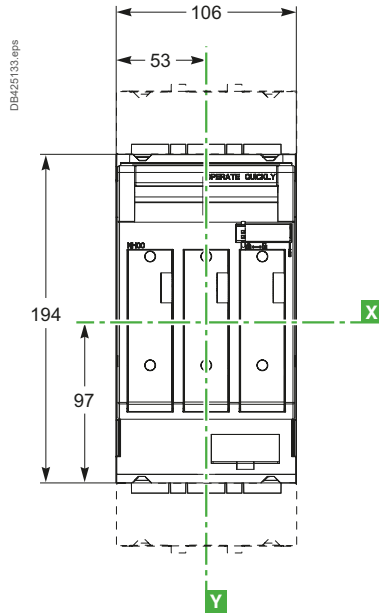

Fuse-carrier open

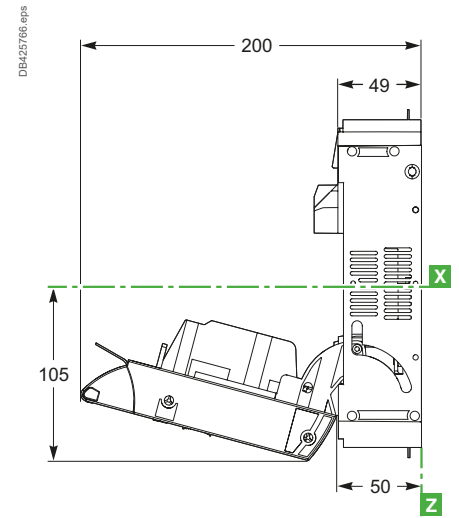

With hook-on

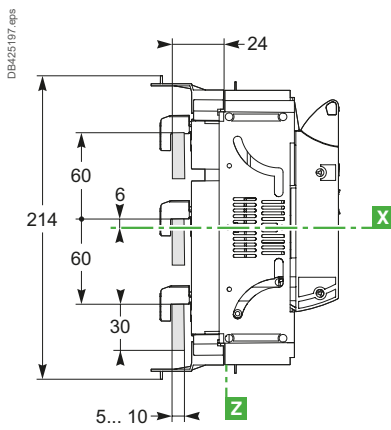

With fuse monitor

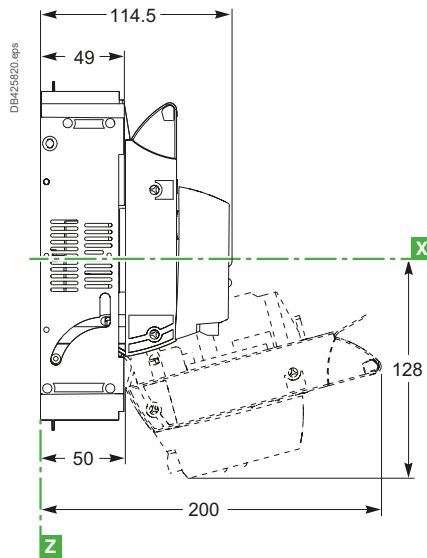

FuPacT ISFT160

Mounting and front panel cut-outs

Mounting

On backplate

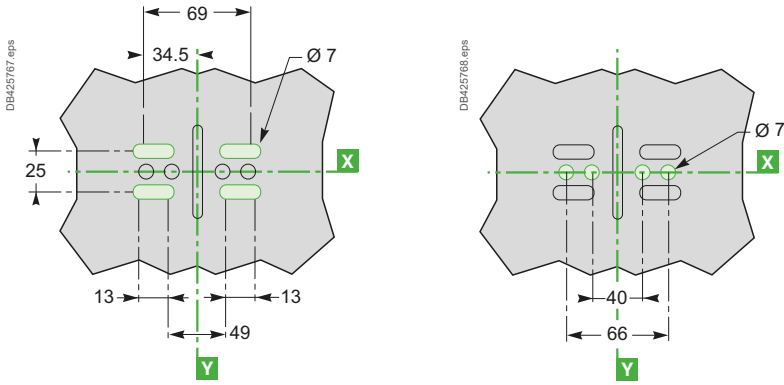

On 60 mm busbars

With hook-on

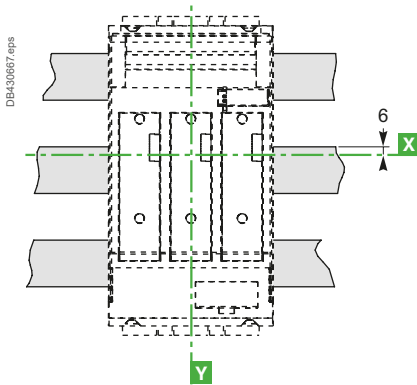

Front panel cut-outs

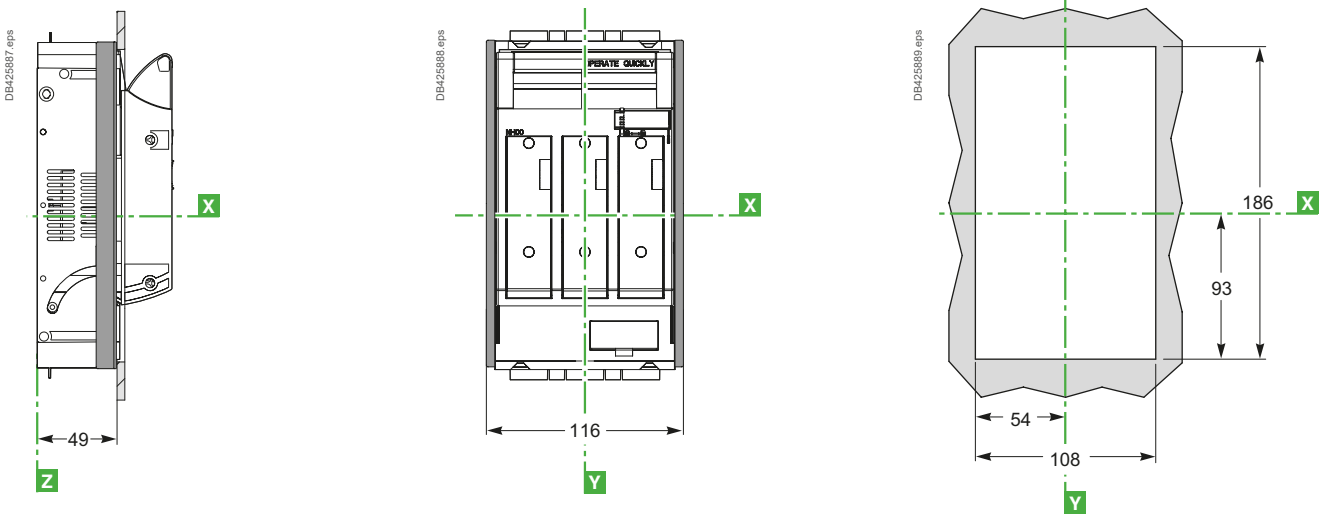

Dimensions and connection

FuPacT ISFT160

Connection and accessories

Front connection to standard M8 terminals

FuPacT ISFT160 devices are also equipped with 12 mm wide terminals with holes for M8 screws for the connection methods presented below.

3 x 16 mm² distribution connector

	L (mm)	25
	S (mm ²)	1.5 to 16 rigid
	Cu/Al	1.5 to 10 flexible ^[1]
	Torque (Nm)	2 (cables) 4 (connectors)

Used with long terminal shields

Connector for flexible bars

	L (mm)	20
	l (mm)	12
	e (Nm)	6
	Torque (mm)	4

Used with short terminal shields

Lug for 95 to 185 mm² copper cables

	L (mm)	< 12
	Ø (mm)	8.2
	Torque (Nm)	14

Used with long terminal shields

^[1] Connection of 2.5 to 4 mm² flexible cables requires crimped or auto-crimping ferrules.

Direct front connection to connectors

FuPacT ISFT160 devices are equipped as standard with connectors for bare copper or aluminium cables from 1.5 to 50 mm² for mounting on backplates.

Standard device

	L (mm)	25
	S (mm ²)	1.5 to 95 rigid
	Cu/Al	1.5 to 70 flexible
	Torque (Nm)	4

Used with short terminal shields

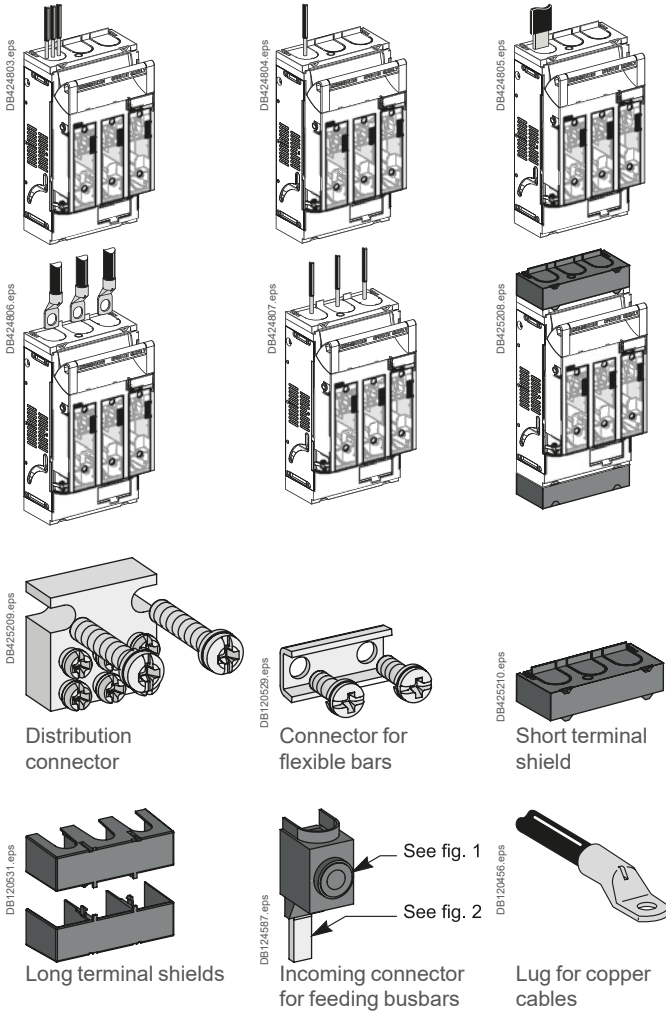

Busbar Usage Recommendation		60 mm	100 mm	185 mm	185mm Sidewise/Coupling
ISFT	ISFT160 3P Fixed Front Connected (M8 terminals)	LV480801	-	-	-
	ISFT160 3P Fixed Front Connected (25 to 95 mm ² Cable connectors (Box clamp))	LV480802	-	-	-
	ISFT160 3P Fixed Front Connected with Turnable Hooks	LV480803	●	-	-

FuPacT ISFT160

Connection and accessories

Connections for mounting on a backplate

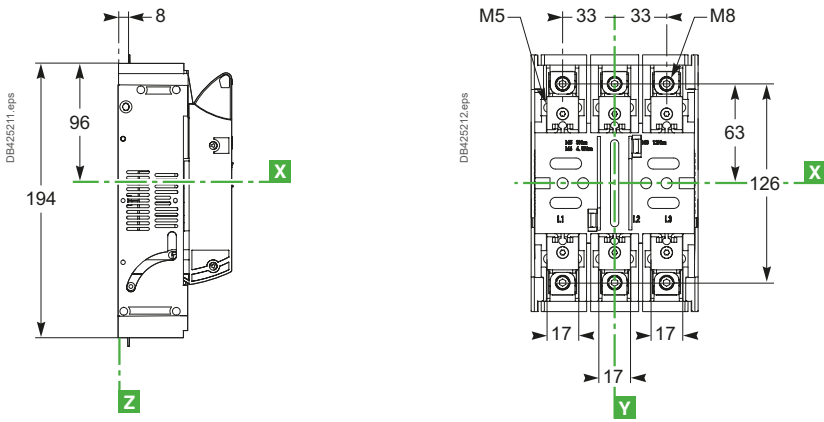

Connections for mounting on 60 mm busbars

Hook-on connection

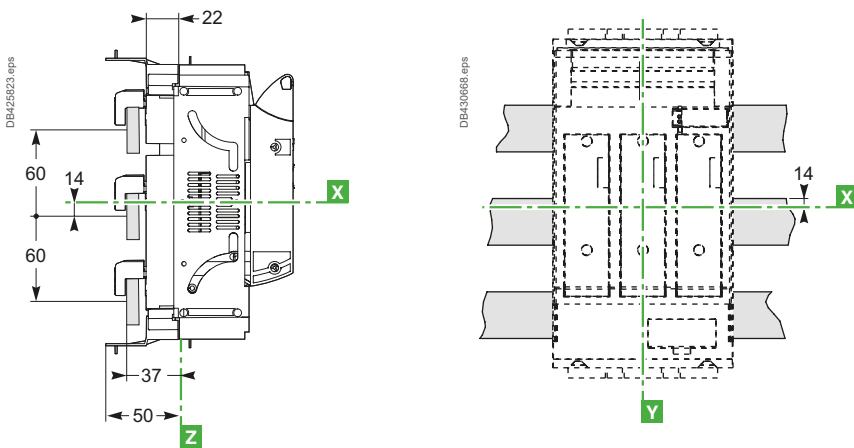

Dimensions and connection

FuPacT ISFT250 to 630

Dimensions and mounting

Dimensions

Fuse-carrier closed

Front

Fuse-carrier open

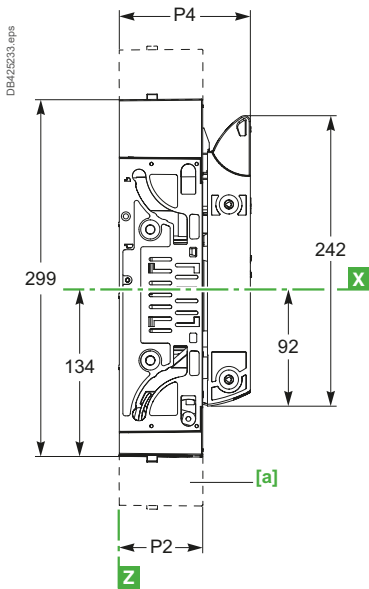

[a] Terminal shields.

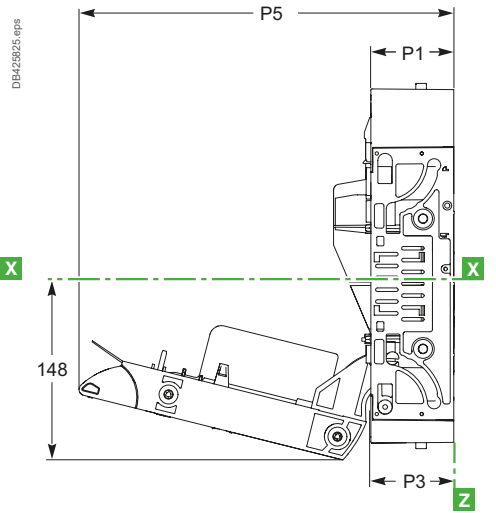
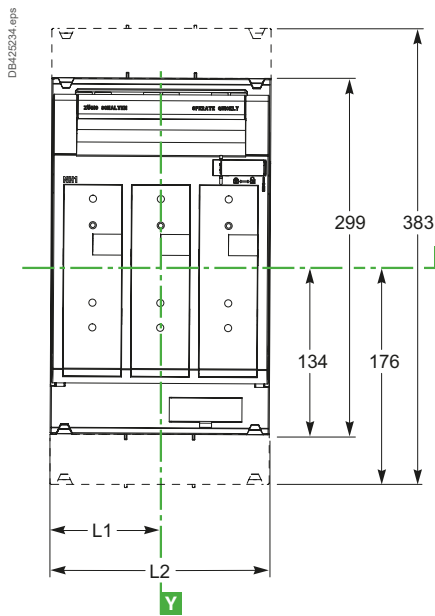

With hook-on for ISFT250/400/630 With fuse monitor for ISFT250/400/630

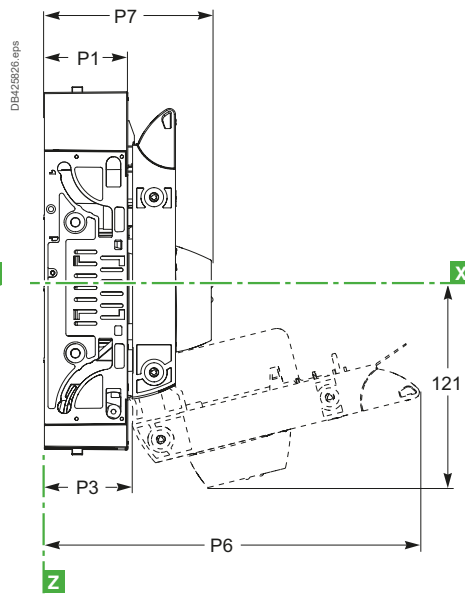
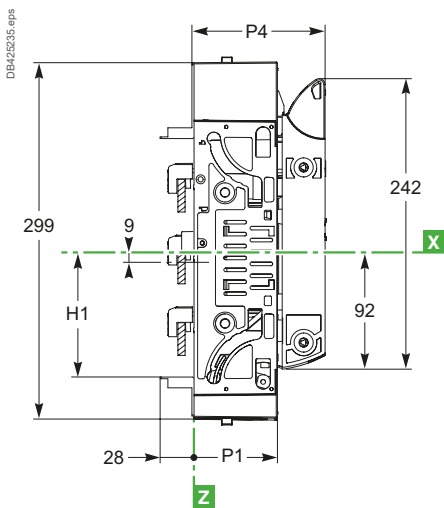

Type	L1	L2	P1	P2	P3	P4	P5	P6	P7
ISFT250	92	184	70	70	74	112	293	316	142
ISFT400	105	210	90	90	94	131	331	319	162
ISFT630	125	250	90	90	94	131	332	319	162



FuPacT ISFT250 to 630

Mounting and front panel cut-outs

Mounting

On a backplate for ISFT250

On a backplate for ISFT400

On a backplate for ISFT630

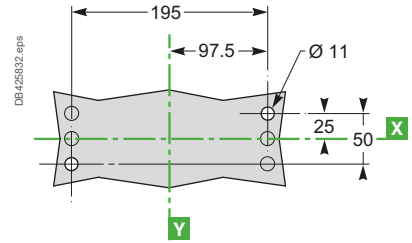
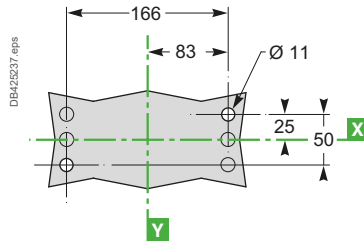
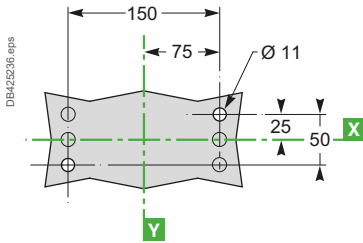

On busbars

With hook-on for ISFT250

With hook-on for ISFT400/630

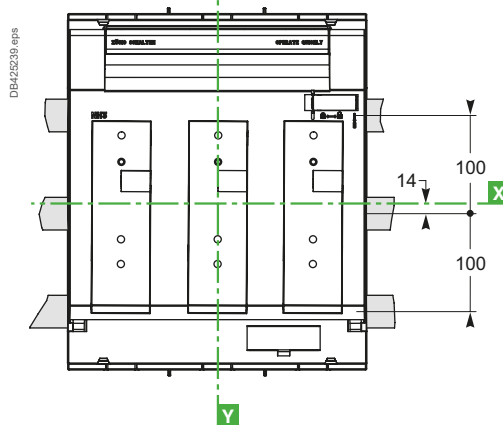
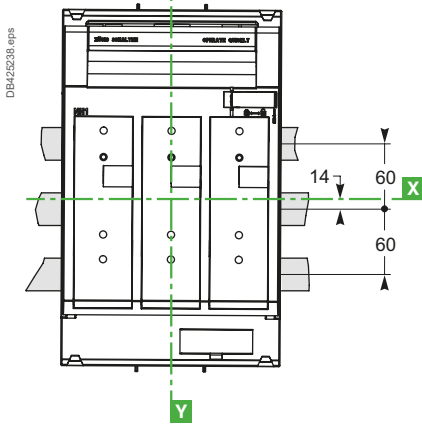

Front panel cut-outs

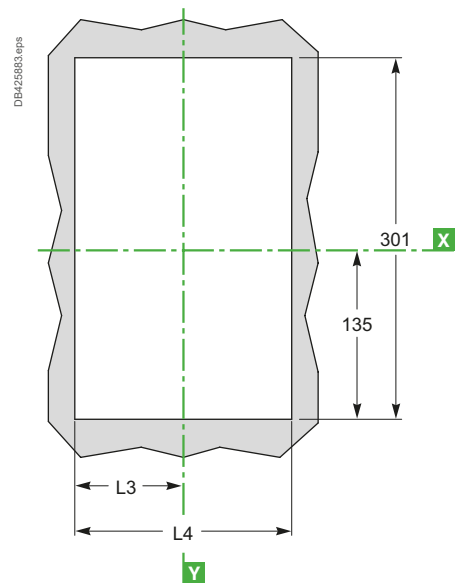
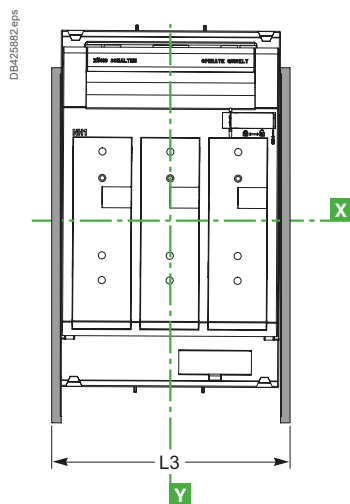
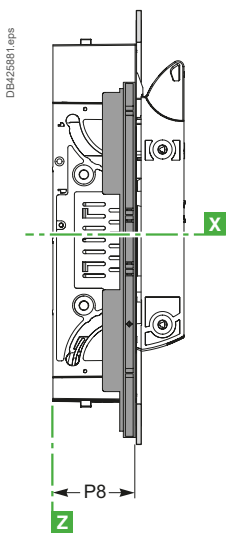

Type	L5	P8	L3	L4
ISFT250	186	70	200	186
ISFT400	212	90	226	212
ISFT630	252	90	266	252

Dimensions and connection

FuPacT ISFT250 to 630

Connection and accessories

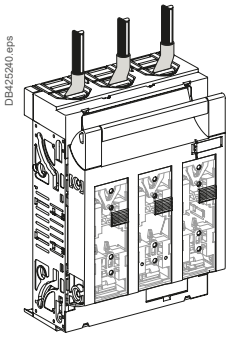

Front connection to standard M10 terminals

FuPacT ISFT250 to 630 devices are equipped as standard with terminals comprising holes for M10 screws for the connection methods presented below.

Connector for flexible bars

	ISFT250	ISFT400/630
L (mm)	20	30
I (mm ²)	16	21
e (mm)	15	15
Torque (Nm)	14	14

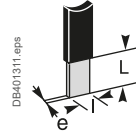

Lug for 100 to 185 mm² copper cables

	ISFT250 to 630
L (mm)	≤ 16
Ø (mm)	10.2
Torque (Nm)	32

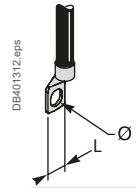

Lug for 240 to 300 mm² copper cables

	ISFT400/630
L (mm)	≤ 21
Ø (mm)	10.2
Torque (Nm)	32

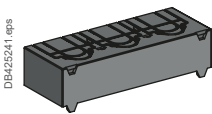
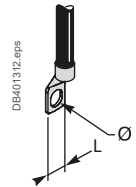

Terminal shields

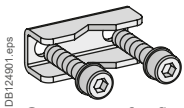

Connector for flexible bars

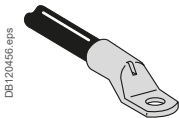

Lug for copper cables

Busbar Usage Recommendation		60 mm	100 mm	185 mm	185mm Sidewise/Coupling
ISFT	ISFT250 Fixed Front Connected	LV480804	-	-	-
	ISFT250 Fixed Front Connected with Turnable Hooks	LV480805	●	-	-
	ISFT630 Fixed Front Connected	LV480806	-	-	-
	ISFT400 Fixed Front Connected with Turnable Hooks	LV480807	●	-	-
	ISFT630 Fixed Front Connected	LV480808	-	-	-



Dimensions and connection

FuPacT ISFT250 to 630

Connection and accessories

Connections for mounting on a backplate

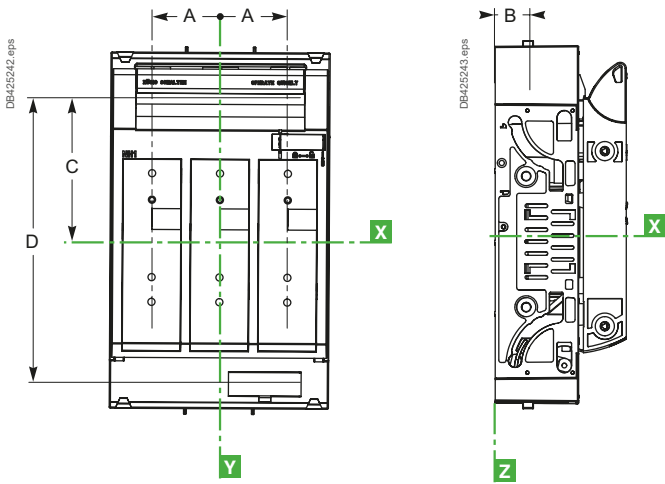

A

Type	A	B	C	D
ISFT250	57	33	93	186
ISFT400	65	36.5	104.5	209
ISFT630	80	36.5	104.5	209

Connections for mounting on 60 mm busbars

Hook-on connection for ISFT250/400

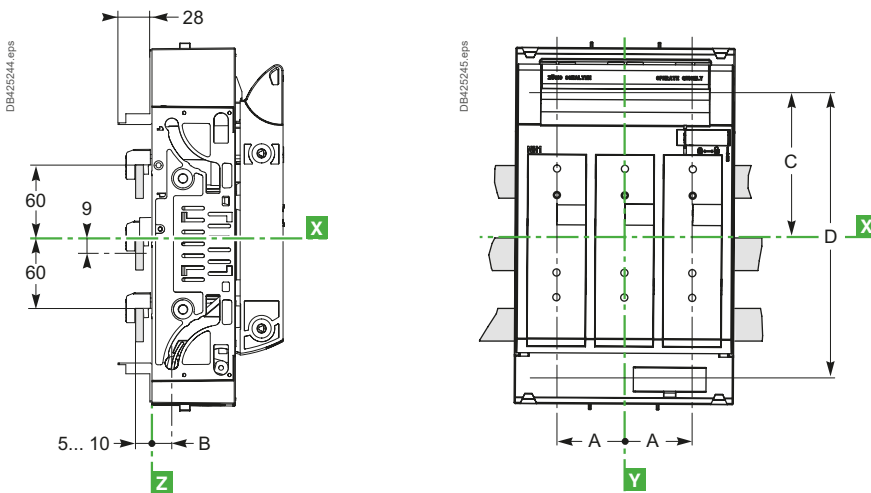

Power

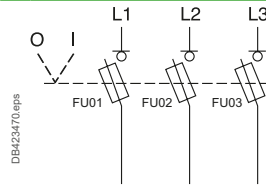

Auxiliary contacts

ISFT100N

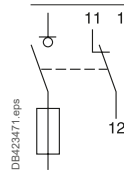

ISFT100 to 630

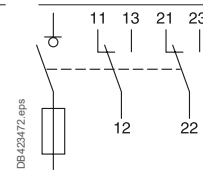

Blown fuse

ISFT160 to 630 Electronic fuse Monitor

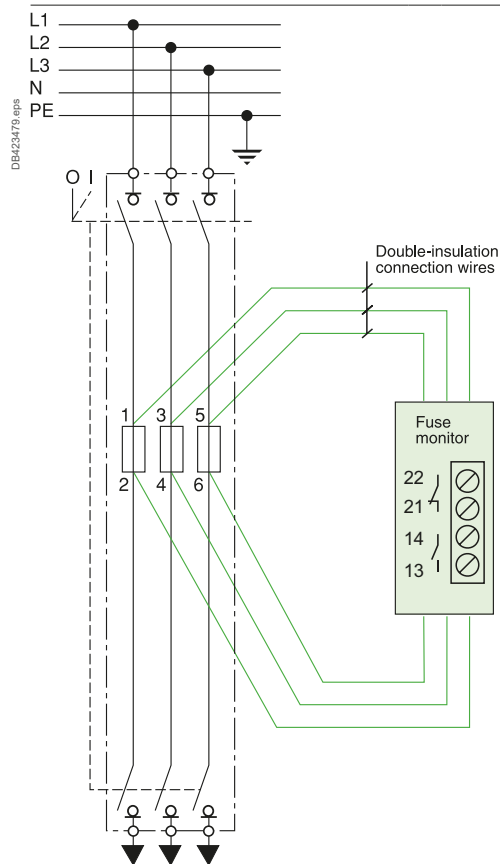

D



B



ISFL160



ISFL250/400/630/1250

FuPacT ISFL

Functions and characteristics

Fuse switch-disconnector selection	B-4
FuPacT ISFL160 to ISFL1250	B-4
Accessories and auxiliaries.....	B-8
FuPacT ISFL160 - 3P	B-8
FuPacT ISFL250 to ISFL630	B-10
FuPacT ISFL1250	B-11
General characteristics: ISFL.....	B-12
FuPacT ISFL160 to ISFL1250	B-12
ISFL installation.....	B-14
FuPacT ISFL160	B-14
FuPacT ISFL250 to ISFL1250	B-15
Connection and accessories	B-16
FuPacT ISFL160 to ISFL1250 - Connection.....	B-16
FuPacT ISFL160 to ISFL630 - Connection, coupling	B-18
FuPacT ISFL160 to ISFL630 - Reverse distribution	B-20
FuPacT ISFL1250 - Reverse distribution	B-21
Insulation	B-22
FuPacT ISFL160 to ISFL630	B-22
FuPacT ISFL250 to ISFL1250	B-23
Fuse monitor	B-24
FuPacT ISFL160 to ISFL1250	B-24
Measurement accessory	B-26
FuPacT ISFL160 to ISFL1250	B-26
Fuse-link monitoring and testing	B-28
FuPacT ISFL160 to ISFL1250	B-28
Control, locking and operation	B-29
FuPacT ISFL160 to ISFL1250	B-29
Auxiliary contacts and indications	B-31
FuPacT ISFL160 to ISFL1250	B-31
FuPacT ISFL160 to ISFL630	B-32
Intelligent measurement.....	B-34
FuPacT ISFL160 to ISFL630	B-34

Other chapters

Presentation	2
FuPacT ISFT	A-1
FuPacT GS	C-1
Catalog numbers	D-1

FuPacT ISFL

Installation recommendations

Possible installation positions and mounting	B-35
FuPacT ISFL160 to ISFL1250	B-35
Implementation and power dissipation	B-36
FuPacT ISFL	B-36

B

Other chapters

Presentation	2
FuPacT ISFT	A-1
FuPacT GS	C-1
Catalog numbers	D-1

FuPacT ISFL

Dimensions and connection

FuPacT ISFL160 3 x 1P	B-38
Dimensions and mounting.....	B-38
FuPacT ISFL160 1 x 3P	B-40
Dimensions and mounting.....	B-40
Connection and accessories.....	B-42
FuPacT ISFL250 to 630 1 x 3P	B-43
Dimensions and mounting.....	B-43
FuPacT ISFL1250	B-45
Dimensions and mounting.....	B-45
Connection and accessories.....	B-47

Wiring diagrams

FuPacT ISFL	B-48
--------------------------	------



Other chapters	
Presentation.....	2
FuPacT ISFT	A-1
FuPacT GS	C-1
Catalog numbers.....	D-1

Fuse switch-disconnector selection

FuPacT ISFL160 to ISFL1250

B



Fuse switch-disconnectors

Number of poles / type of fuse-link IEC60 269-2-1 Section 1

Electrical characteristics as defined by IEC 60947-1 / IEC 60947-3 and EN 60947-1 / EN 60947-3

Conventional thermal current (A)	In free air	I_{th}	at 40 °C
			Maximum fuse power dissipation (W)
	In enclosure	I_{the}	at 40 °C
			Maximum fuse power dissipation (W)
Rated insulation voltage (V)		U_i	AC 50/60 Hz / DC
Rated impulse withstand voltage (kV)		U_{imp}	
Rated operational voltage (V)		U_e	AC 50/60 Hz
Rated operational voltage AC20 and DC20 (V)		U_e	
Rated operational current (A)		I_e	AC 50/60 Hz
			220/240 V
			380/415 V
			440/480 V ^[1]
			500 V
			660/690 V
			800 V
			DC/poles in series
			125 V /nbr of poles
			220 V /nbr of poles
			440 V /nbr of poles

Rated duties	Uninterrupted duty	
Breaking Capacity with Fuses (kARMS)	I_q	415 V 500 V 690 V
Short circuit making capacity (kA peak) / Fuse nominal current (A) / Switch-disconnector with fuse protection (fuse link) ^[2]	I_{cw} (1s) / I_{cm} / I_n fuse	415 V 500 V 690 V 800 V
Conditional short circuit with fuse link at 800 V		800 V
Endurance (category B) (CO cycles)		Mechanical Electrical AC AC23B 415 V AC22B 500 V AC21B 690 V

Suitability for isolation
Positive contact indication
Pollution degree

Control

Direct handle (operator-dependent opening and closing)
Locking Padlocks
Lead seal

Indication auxiliaries

Auxiliary contacts
Current transformer

Installation and connection accessories

Possible mounting position Horizontal
Vertical
Connector For bare Cu/Al cables
For flexible bars

Lugs for Cu/Al cables
Terminal shields

Dimensions and weight

Overall dimensions H x W x D (mm)	3P
Approximate weight without fuse-links (kg)	3P

[1] Suitable for 480 V NEMA.
[2] Fuse-switch disconnectors with fuse-links.
[3] Only for ISF160 with direct connection to the busbars.
[4] AC22B 690 V.
[5] 800 A for 60 mm & 100 mm busbar and 1000 V for 185 mm busbar.

Fuse switch-disconnector selection

FuPacT ISFL160 to ISFL1250

ISFL160			ISFL250			ISFL400			ISFL630			ISFL1250	
3 x 1P or 3P/DIN (NH00)			3 x 1P or 3P/DIN (NH1)			3 x 1P or 3P/DIN (NH2)			3 x 1P or 3P/DIN (NH3)			3P/DIN (NH3)	
160			250			400			630			1250	
12			23			34			48			2 x 48	
160			250			400			630			1250	
12			23			34			48			2 x 48	
800/1000 ^[5]			1000			1000			1000			1000	
8			12			12			12			12	
690			690			690			690			690	
800/1000 ^[5]			1000			1000			1000			1000	
AC21B	AC22B	AC23B	AC21B	AC22B	AC23B	AC21B	AC22B	AC23B	AC21B	AC22B	AC23B	AC21B	AC22B
160	160	160	250	250	250	400	400	400	630	630	630	1250	1250
160	160	160	250	250	250	400	400	400	630	630	630	1250	1250
160	160	-	250	250	-	400	400	-	630	630	-	1250	1250
160	160	-	250	250	-	400	400	-	630	630	-	1250	1250
160	160	-	250	-	-	400	-	-	630	-	-	1250	-
80	-	-	200	-	-	250	-	-	400	-	-	-	-
DC21B	DC21B	DC22B	DC21B	DC22B		DC21B	DC22B		DC21B	DC22B		DC21B	DC22B
-	-	-	-	-		-	-		-	-		-	-
-	-	-	-	-		-	-		-	-		-	-
-	-	-	-	-		-	-		-	-		-	-
⊙			⊙			⊙			⊙			⊙	
100			120			120			120			80	
100			120			120			120			80	
100			100			100			100			80	
5kA/7.65kA/160A			10kA/15kA/250A			10kA/15kA/400A			15kA/22kA/630A			25kA/28kA/630A	
5kA/7.65kA/160A			10kA/15kA/250A			10kA/15kA/400A			15kA/22kA/630A			25kA/28kA/630A	
5kA/7.65kA/160A			10kA/15kA/250A			10kA/15kA/400A			15kA/22kA/630A			25kA/28kA/630A	
50kA			50kA			50kA			50kA			-	
1400			1400			800			800			500	
200			200			200			200			100	
200 ^[4]			200			200			200			100	
200			200			200			200			100	
⊙			⊙			⊙			⊙			⊙	
⊙			⊙			⊙			⊙			⊙	
3			3			3			3			3	
⊙			⊙			⊙			⊙			⊙	
⊙			⊙			⊙			⊙			⊙	
-			-			-			-			-	
⊙			⊙			⊙			⊙			⊙	
⊙ ^[3]			⊙			⊙			⊙			⊙	
⊙			-			-			-			-	
⊙			⊙			⊙			⊙			⊙	
⊙			⊙			⊙			⊙			⊙	
⊙			-			-			-			-	
⊙			-			-			-			-	
included			included			included			included			included	
405 x 50 x 123			741 x 100 x 190			741 x 100 x 190			741 x 100 x 190			834 x 200 x 190	
1.30			4.70			5.00			5.60			15.20	

B

Fuse switch-disconnector selection

FuPacT ISFL160 to ISFL1250

B

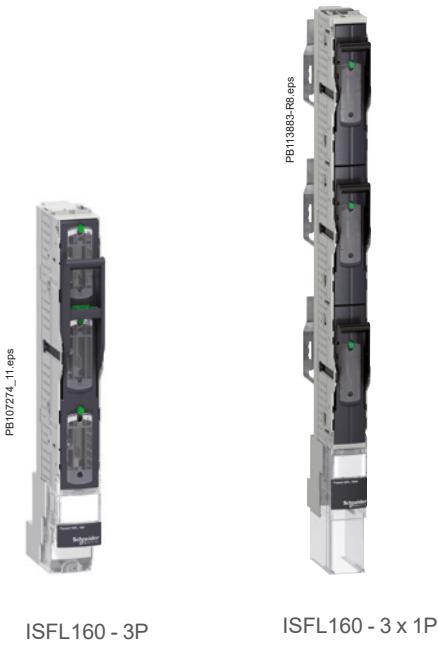

ISFL160 - 3P

ISFL160 - 3 x 1P



ISFL250 - 3P

ISFL250 - 3 x 1P

Fuse switch-disconnectors

Type of fuse-link

- DIN NH000
- DIN NH00
- DIN NH1
- DIN NH2
- DIN NH3

Installation and connection

- ISFL160 for 60 mm busbar hook-on contact mounting with multiple use terminal (screw M8)
- ISFL160 for 60 mm busbar hook-on contact mounting with box terminal 95 mm²
- ISFL160 for 100 mm busbar hook-on contact mounting with multiple use terminal (screw M8)
- ISFL160 for 100 mm busbar hook-on contact mounting with box terminal 95 mm²
- Conversion kit for 185 mm busbar direct contact mounting (for 1 or 2 x ISFL160)
- ISFL160 for 185 mm busbar 1-pole switchable direct mounting
- ISFL160 for 185 mm busbar 1-pole switchable hook-on mounting

Terminal tightening torque (Nm)

Temperature derating (with gG fuse-link)^[1]

"Vertical mounting" fuse-links in vertical position	I _{th} (A)	40 °C
		45 °C
	50 °C	
	55 °C	
	60 °C	
	65 °C	
	70 °C	
"Horizontal mounting" fuse-links in horizontal position	I _{th} (A)	40 °C
		45 °C
		50 °C
		55 °C
		60 °C
		65 °C
		70 °C

[1] Derating data is based on:
 - the maximum rating for fuse-links intended for the device
 - maximum power dissipation.

Fuse switch-disconnector selection

FuPacT ISFL160 to ISFL1250

	ISFL160	ISFL250	ISFL400	ISFL630	ISFL1250
	○	-	-	-	-
	○	-	-	-	-
	-	○	○	-	-
	-	-	○	○	-
	-	-	-	○	○
	○	-	-	-	-
	○	-	-	-	-
	○	-	-	-	-
	○	-	-	-	-
	○	○	○	○	○
	○	○	○	○	○
	see page B-36				
	160	250	400	630	1250
	150	240	380	600	1200
	145	225	360	570	1130
	135	215	340	535	1070
	130	200	320	500	1000
	120	190	300	475	940
	110	175	280	440	880
	160	-	-	-	-
	150	-	-	-	-
	145	-	-	-	-
	135	-	-	-	-
	130	-	-	-	-
	120	-	-	-	-
	110	-	-	-	-

B

Accessories and auxiliaries

FuPacT ISFL160 - 3P

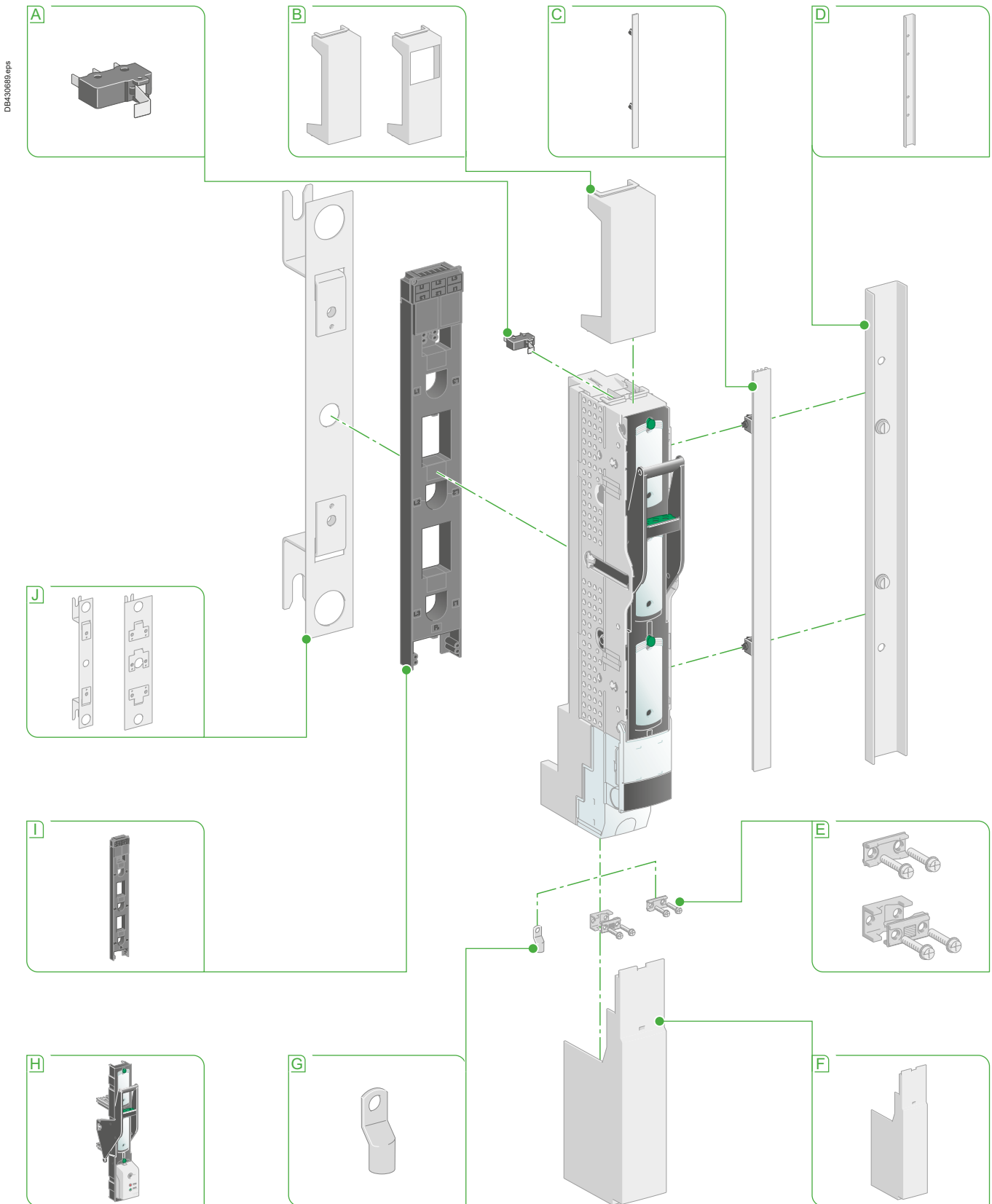

A NO + NC auxiliary changeover contacts

B Length adapter

C Side cover for front panel cut-out

D Blank panel cover for free slot

E Connectors for :
 ■ bare cable
 ■ flexible bars

F Length adapter

G Lug for copper cable

H Fuse monitor

I Current transformer

J Conversion kit for direct connection to 185 mm busbars

Accessories and auxiliaries FuPacT ISFL160 - 3 x 1P

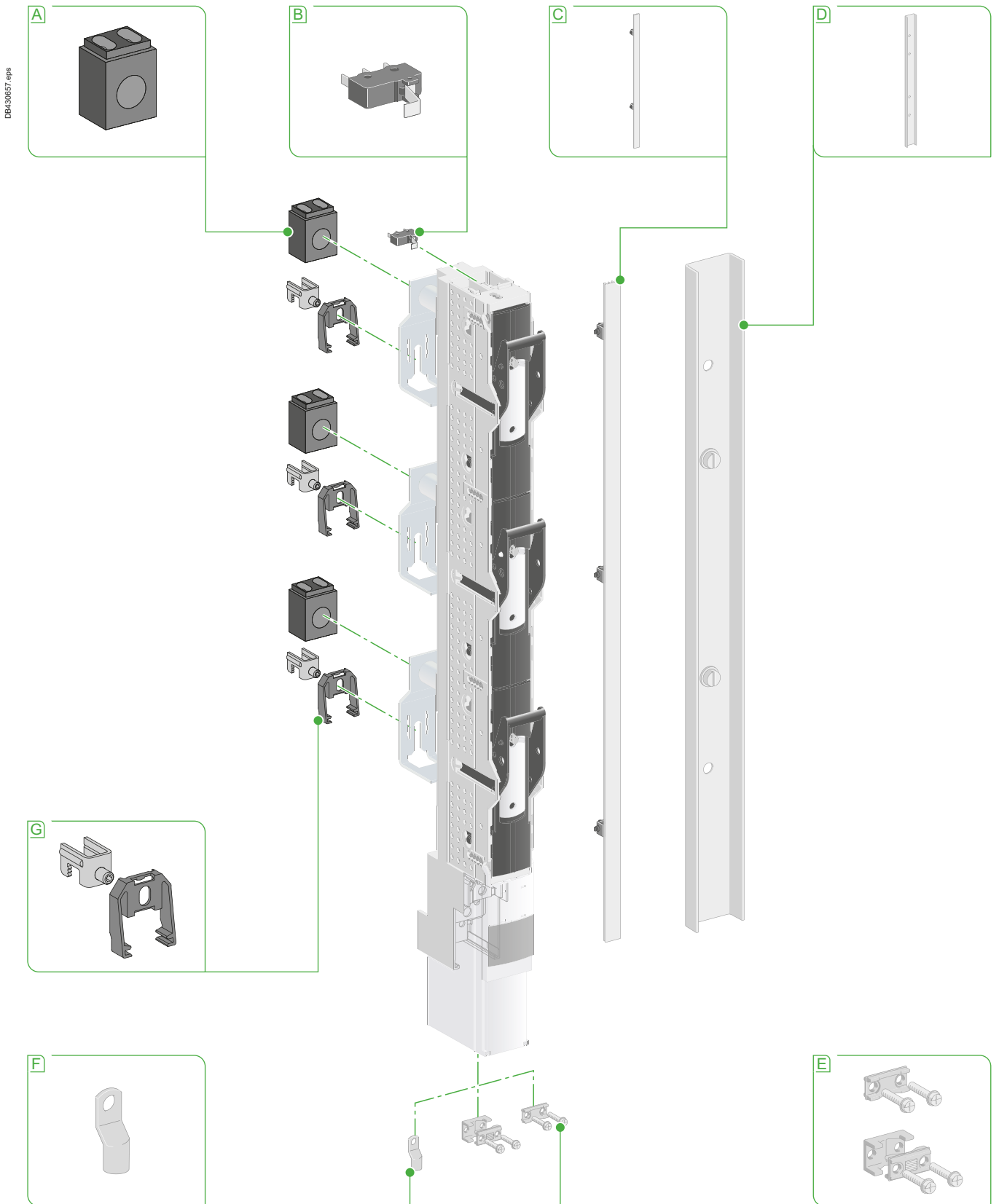

- A** Current transformer
- B** NO + NC auxiliary changeover contacts
- C** Side cover for front panel cut-out
- D** Blank panel cover for free slot

- E** Connectors for :
 - bare cable
 - flexible bars
- F** Lug for copper cable
- G** Hooks

Accessories and auxiliaries

FuPacT ISFL250 to ISFL630

DE439690.eps

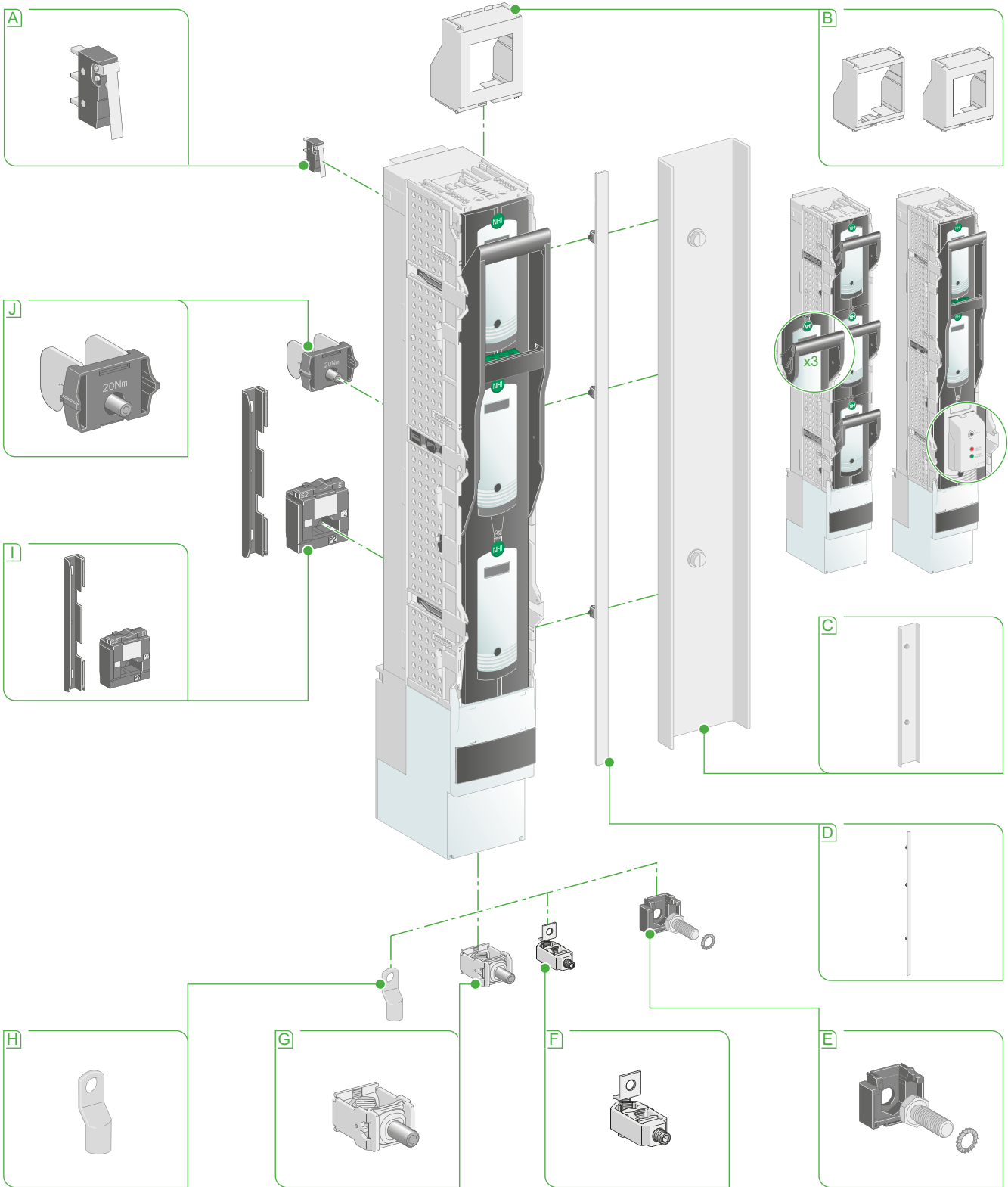

- A** NO + NC auxiliary changeover contacts
- B** Empty plastic box
- C** Blank panel cover for free slot
- D** Side cover for front panel cut-out

- E** Screws with plastic support
- F** Connector for Cu/Al bare cables 2 x 50 to 185 mm²
- G** Connector for Cu/Al bare cables 1 x 35 to 300 mm²

- H** Lug for copper cable
- I** Current transformer
- J** Hooks

Accessories and auxiliaries

FuPacT ISFL1250

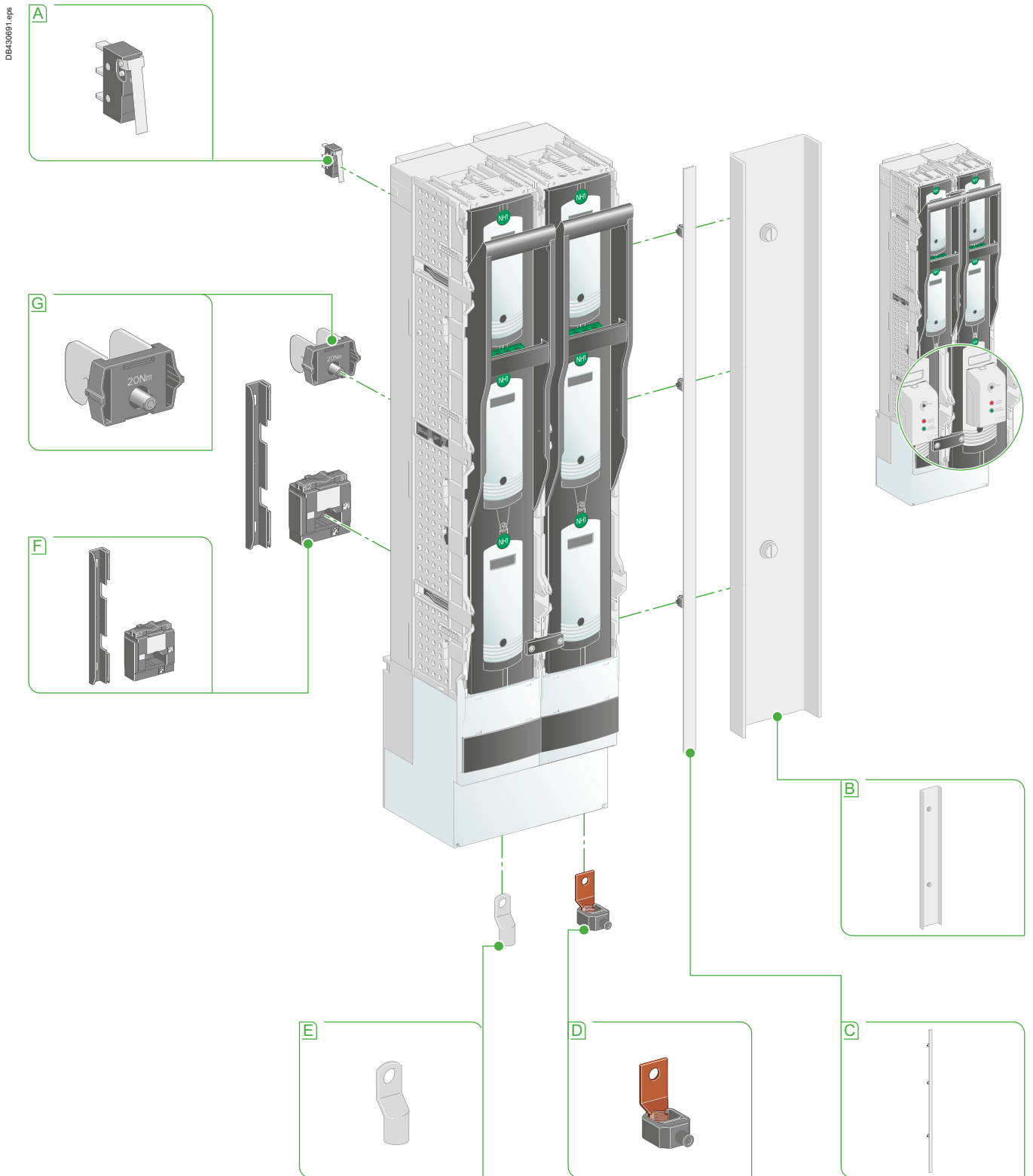

- A** NO + NC auxiliary changeover contacts
- B** Blank panel cover for free slot
- C** Side cover for front panel cut-out
- D** Connector 4 x 240 mm²

- E** Lug for copper cable
- F** Current transformer
- G** Hooks

General characteristics: ISFL

FuPacT ISFL160 to ISFL1250



ISFL turnable hooks

PP107611_00mm.eps

B

With FuPacT ISFL, you have one of the most efficient vertical NH fuse switch-disconnectors ever designed with compact dimensions, a modular system and an elegant design. Your benefit are as follows:

Future proof

The trend is moving from simple power distribution stations to more intelligent power distribution stations. FuPacT ISFL is made for the future: with interfaces for measurement and control equipment which can be integrated in a space-saving manner.

Reduced heat development

Safeguarding high currents requires one thing above all: keeping a cool head. This is where FuPacT ISFL leads the pack. They feature one of the lowest heat development values of all products available on the market. This pays off for your entire facility: reduced energy loss, improved operating safety and durability.

Faster mounting

All installation and connecting components of the FuPacT ISFL were optimized and the number of assembling steps was reduced. This puts your switch "on the track" even more quickly.

Safety in mind

The switch gears are very user friendly and provide optimal user protection due to parallel switching. Two disconnected positions per phase produce two smaller electrical arcs. This causes only half the arc voltage.

Turnable contact hooks

FuPacT ISFL fuse-switches, vertical design, 00/60 are the first of its kind to feature turnable contact hooks. This makes it much easier to mount the NH Fuse-Switch on the busbar in addition to being much more flexible. Due to its symmetry, the NH Fuse-Switch can be turned around at any time. Terminal top or bottom can be chosen freely. Thus, only one version needs to be placed on stock.

Fast connection – with variable box terminals

High currents require large cable cross-sections. At the same time, modern switchboard cabinets are becoming more and more compact. They accommodate three cables of up to 95 mm² in the smallest possible. No one else can do that with a FuPacT ISFL 160 A. This is possible only due to the stepped and slightly offset arrangement of the box terminals. Captive screws enable a quick and reliable securing of the cable.

Optimized back-up with space-saving current-transformer installation

Do you wish to measure currents in addition to safeguarding them? We have redefined space for you. Our new current transformers can be installed behind the FuPacT ISFL, vertical design, without an alteration of installation depth. After removing the break-out-pieces from the socket, the current transformers is simply plugged on – ready for use. With or without a current transformer, the FuPacT ISFL always has the same installation depth, so no adaptors are required.

General characteristics: ISFL

FuPacT ISFL160 to ISFL1250

The elegant solution

To obtain the same installation depth with surrounding devices, the FuPacT ISFL vertical design, size 00/185 does not only come with conventional adapters but also features raised busbar connections. This makes it easy to mount the fuse-switch adjacent to devices of size 1 to 3. Simply hook the elevated feeding bracket onto the pre-mounted bolts or attach it with the contact hooks. There is no need for drilling. This allows the same installation depth for all sizes, giving the front face a clear uniform look.

No trouble with large cross-sections

Standard universal terminals allow the direct connection of cable lugs as well as cables with cross-sections up to 300 mm². Easy-to-install terminal hardware gives you great flexibility. No other small-sized FuPacT ISFL can do that.

Appealing at first sight

Rotating nameplates turn your installation possibilities into a real eye-catcher. No matter if the terminal is located on top or at the bottom, technical data and installation labels of all FuPacT ISFL are always correctly aligned.

Turn-off-position – up to three padlocks

Even fuse-protection-devices need to be protected: from electricity-theft, manipulation and unauthorized use. This is why every 3-pole FuPacT ISFL, vertical design, may be locked with up to three locks. This is possible in both, the closed and the secure padlock position.

Intelligent measurement

The future belongs to more intelligent switchboards. FuPacT ISFL is well prepared for the future: it offer standardized interface for measurement devices.

Contemporary power management

FuPacT ISFL measuring devices offers a large selection of measuring and monitoring options: from basic current measurements and power metering, harmonic wave analysis to remote management and alarm relays, and many more. All electrical parameters are visualized on an LCD and can be centralized. EM measuring devices are normally installed separately in the switchboard. FuPacT ISFL offer an integrated solution which can simply be plugged on.

Electronic Fuse-Monitoring - Everything under control

You know what happens and where it happens almost instantly to a notification, technician receives the information required to precisely locate and quickly correct short-circuits and overloads. Your technician will be faster to analyze and change fuse which is broken.

Condition of usage

It can only be used with $U < 690$ V AC.

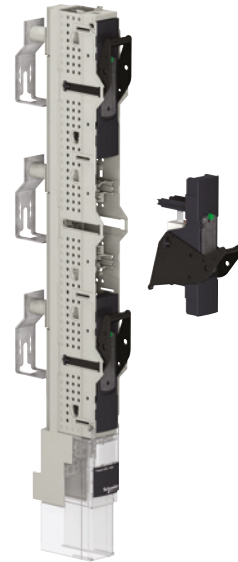

FuPacT ISFL160 - 3 x 1P



FuPacT ISFL630 with fuse monitor

ISFL installation

FuPacT ISFL160

FuPacT ISFL fusegear is installed vertically and connected directly to the busbars. The connection is bolted or could be made by the hook-on connection.

B

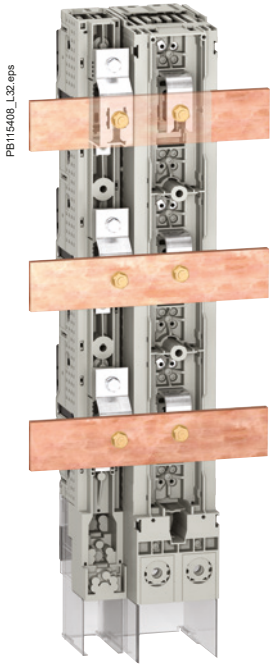

PB115408_L32.eps

Direct connection to the busbars (ISFL160 and ISFL400)

ISFL160 fusegear

Connection to busbars.

The power circuit is connected:

- Directly to the 100 mm busbars for 3-pole version or to the 185 mm busbars for 1-pole version
 - Using a hook-on connection to 60 mm busbars (3-pole version)
 - Via a conversion kit for connection to 185 mm busbars (3-pole version)
 - Via a conversion kit for two devices and for connection to 185 mm busbars.
- Downstream connection of distribution circuits requires cables (3-pole version).



DB423382.eps

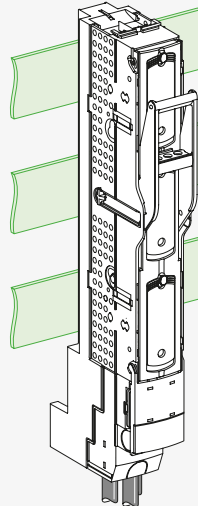

DB423383.eps

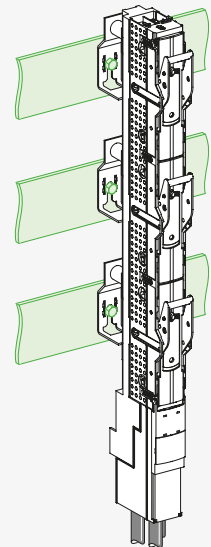

DB423384.eps

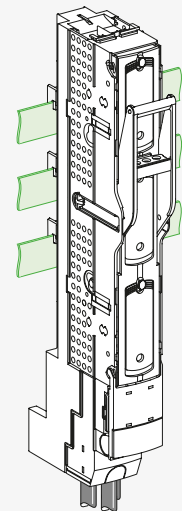

DB423385.eps

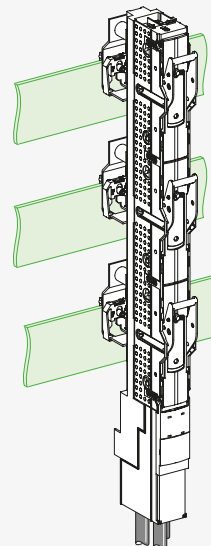

ISFL installation

FuPacT ISFL250 to ISFL1250

ISFL250/400/630 fusegear

Connection to busbars.

The power circuit is connected:

- Directly to the 185 mm busbars for 1-pole and 3-pole version
- Using a hook-on connection to 185 busbars

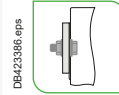
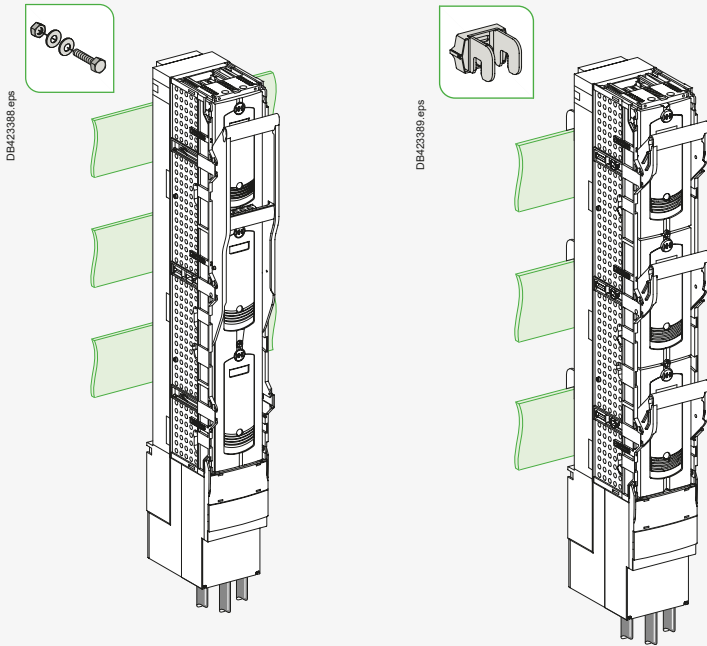

Direct connection to the busbars: the device is bolted to the busbars with one connection point per phase that allows for both electrical connection and robust mechanical mounting.

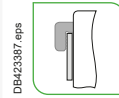

Hook-on connection to busbars: the device tightly hooks on to the busbars via three hooks that allows for both electrical connection and robust mechanical mounting.

These two systems allow for or enable direct contact of the power circuit to the busbars and usual connections for downstream distribution (bare cable connectors, lugs, bars, distribution connectors, etc.).

ISFL1250 fusegear

Connection to busbars.

The power circuit is connected:

- Directly to the 185 mm busbars for 3-pole version
- Using a hook-on connection to 185 mm busbars

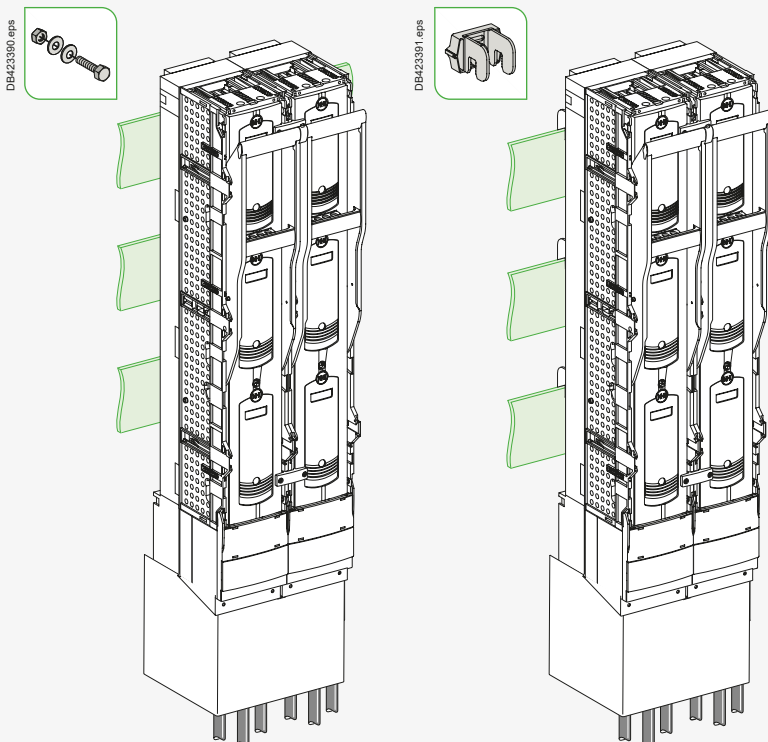

The two connection systems can also be reversed to supply distribution circuits via the upstream terminals.



Connection and accessories

FuPacT ISFL160 to ISFL1250 - Connection

FuPacT ISFL fuse-switch disconnectors can supply distribution circuits via either the upstream or downstream terminals.
 Devices intended for connection to busbars are configured as standard for distribution via the downstream terminals.

ISFL fusegear is equipped with connectors or terminals for front connection of:

- Cables with lugs for the ISFL160 and ISFL1250 devices
- Flexible bars for the ISFL160 devices
- Bare cables for ISFL160 to 630 devices.

	ISFL160	ISFL250	ISFL400	ISFL630	ISFL1250
Cables					
Lug	95 mm ²	-	-	-	-
Cable connector to terminal	1.5 to 95 mm ²	1 x 35 to 300 mm ²	-	-	-
	-	2 x 50 to 185 mm ²	-	-	-
Flexible bars					
Connector	12 x 6 mm	-	-	-	-

ISFL160 fusegear ^[1]

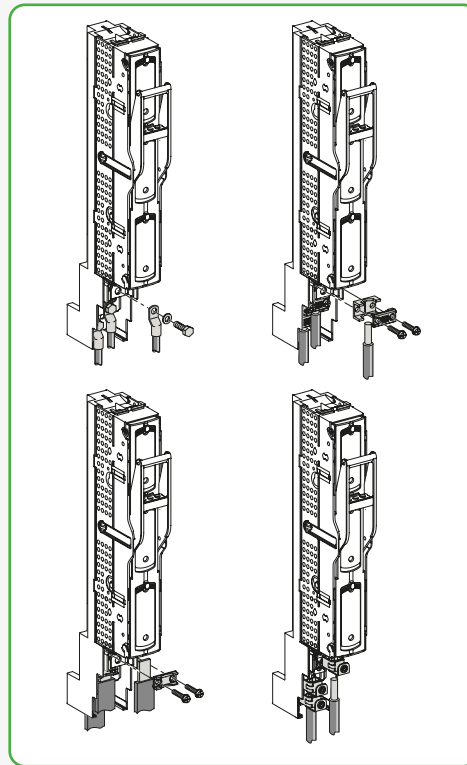

[1] Connections and accessories are identical for ISFL single phase.

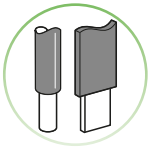

DB423386.eps



62330a_12_15.eps

Lug for copper cables



62329a_3.eps

Connector for bare Cu/Al cables



62244a_3.eps

Connector for flexible bars

Busbar Usage Recommendation

ISFL			60 mm	100 mm	185 mm	185mm Sidewise/Coupling
ISFL	ISFL160 60mm Busbar Hook-on Screws M8	LV480850	●	●	kit LV480854	2xISFL with kit LV480855
	ISFL160 60mm Busbar Hook-on Screws 95mm ²	LV480851	●	●	kit LV480855	2xISFL with kit LV480855
	ISFL160 DIRECT 100mm Busbar Screws M8	LV480852	●	●	kit LV480856	2xISFL with kit LV480855
	ISFL160 Direct 100mm Busbar Terminal 95mm ²	LV480853	●	●	kit LV480857	2xISFL with kit LV480855
	ISFL250 Direct 185mm Busbar Screws M12	LV480856	-	-	●	Coupling with kit LV480891
	ISFL400 Direct 185mm Busbar Screws M12	LV480857	-	-	●	Coupling with kit LV480891
	ISFL630 Direct 185mm Busbar Screws M12	LV480858	-	-	●	Coupling with kit LV480891
	ISFL1250 Busbar 185mm Screws M12	LV480875	-	-	●	Coupling with kit LV480891
	ISFL250 with Electronic Fuse Monitor	LV480863	-	-	●	Coupling with kit LV480891
	ISFL400 with Electronic Fuse Monitor	LV480864	-	-	●	Coupling with kit LV480891
	ISFL630 with Electronic Fuse Monitor	LV480865	-	-	●	Coupling with kit LV480891
	ISFL1250 with Electronic Fuse Monitor	LV480876	-	-	●	Coupling with kit LV480891

Connection and accessories

FuPacT ISFL160 to ISFL1250 - Connection

ISFL250/400/630 fusegear [1]

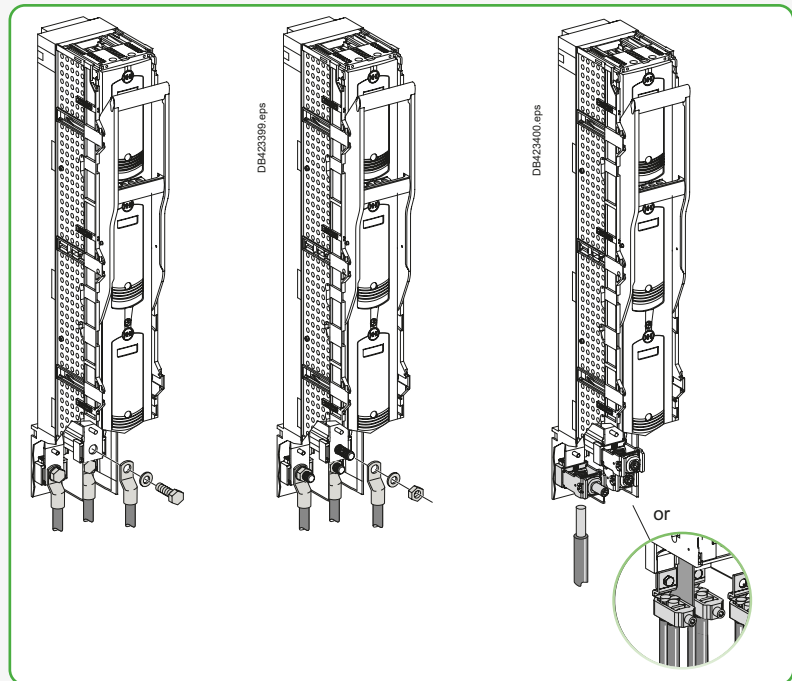

62330a_1-2_15.eps

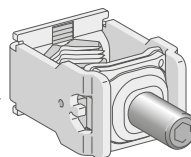

DB402725.eps

Connector for Cu/Al bare cable 1 x 35 to 300 mm²



PB101086-22.eps

Connector for Cu/Al bare cable 2 x 50 to 185 mm²

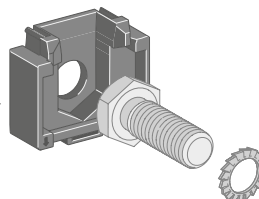

DB402726.eps

Connector for cables with lugs



PB115880_08.eps

Connector 4 x 240 mm²

ISFL1250 fusegear

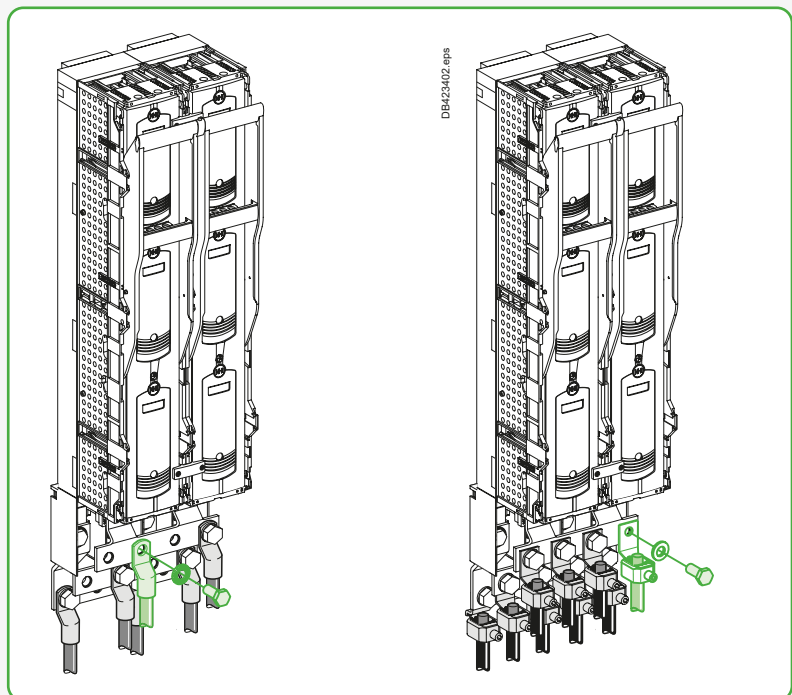

DB423401.eps

DB423402.eps

[1] Connections and accessories are identical for ISFL single phase.



Connection and accessories

FuPacT ISFL160 to ISFL630 - Connection, coupling

Two conversion kits are available for ISFL160 3-pole switchable to adapt the 100 mm standard fixing centres to 185 mm fixing centres.

Direct connection to 185 mm busbars

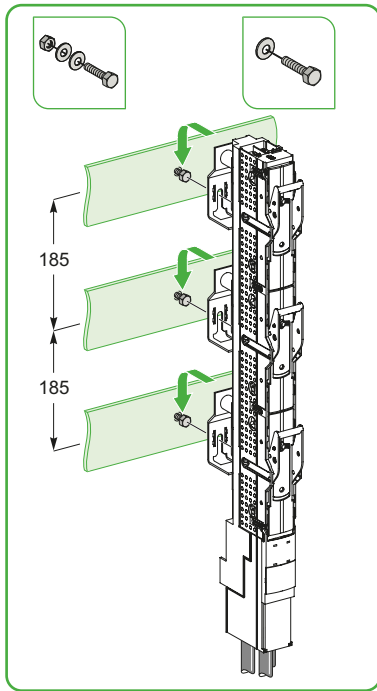

ISFL160 1P

Conversion from 100 to 185 mm

The kit connects to the busbars via a hook-on connection.

Conversion kit for 185 mm busbars includes electrical and mechanical connections to the busbars (set of nuts and bolts).

Electrical and mechanical connection of the device to 100/185 mm conversion kit is ensured by three screws.

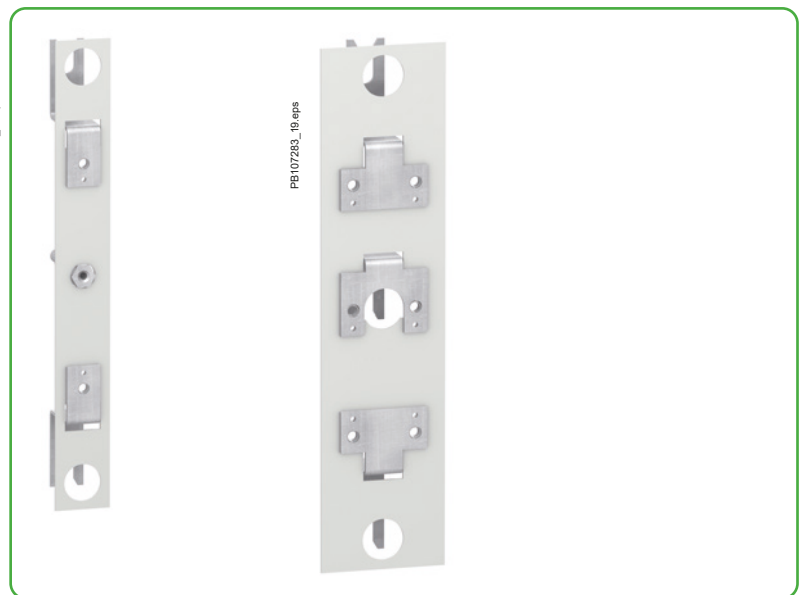
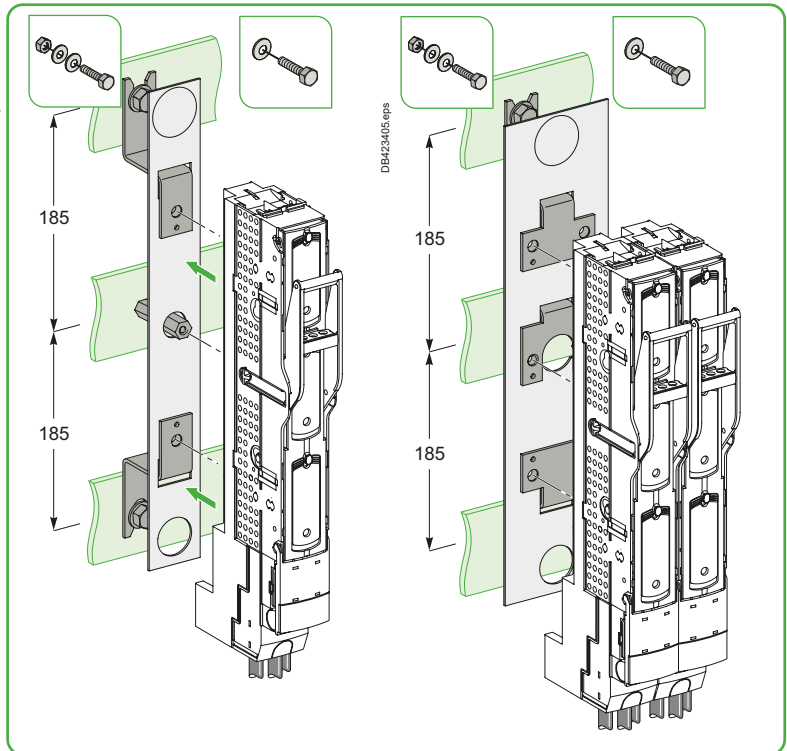

ISFL160 (185 mm kit)

B

Connection and accessories

FuPacT ISFL160 to ISFL630 - Connection, coupling

Installation of devices with different ratings on a given set of busbars

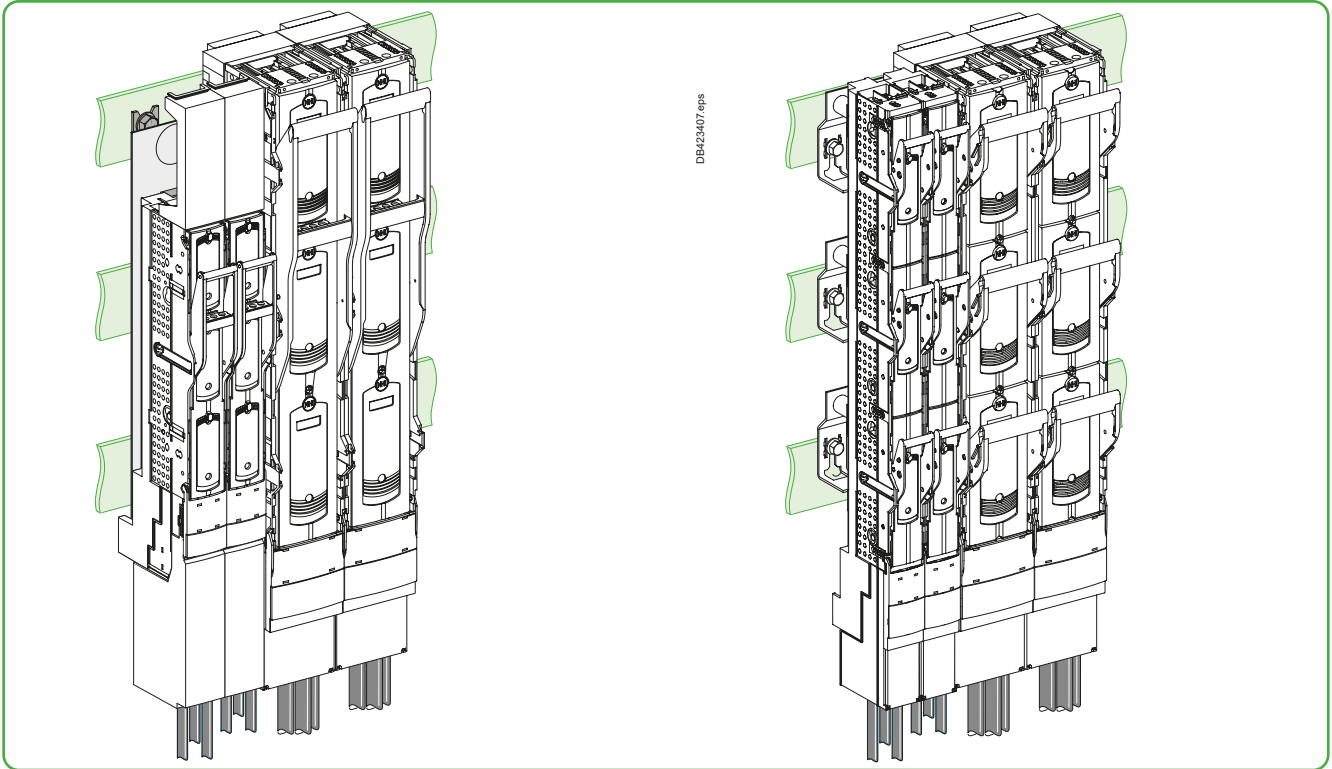

B

Coupling kit from ISFL250 to ISFL630

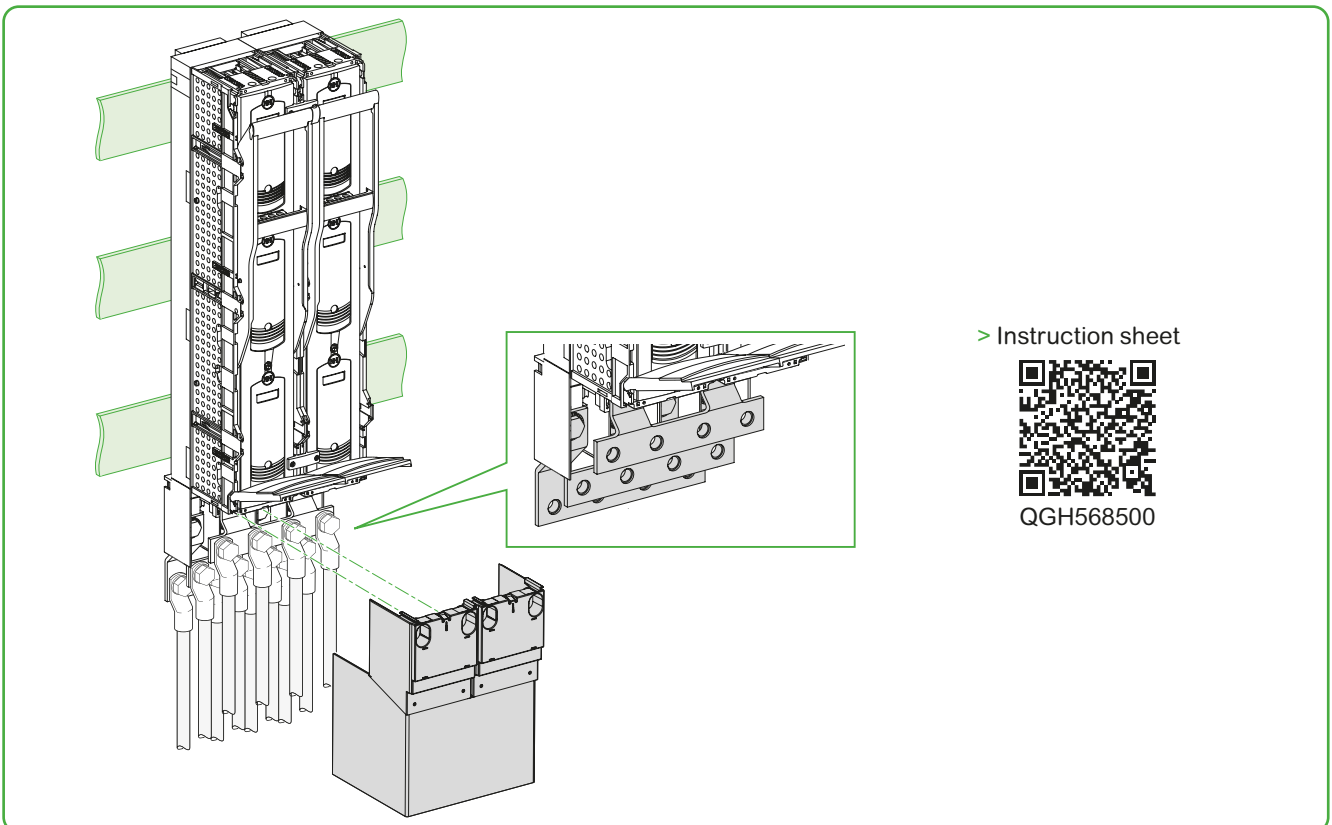

Connection and accessories

FuPacT ISFL160 to ISFL630 - Reverse distribution

PB115408_L32.eps

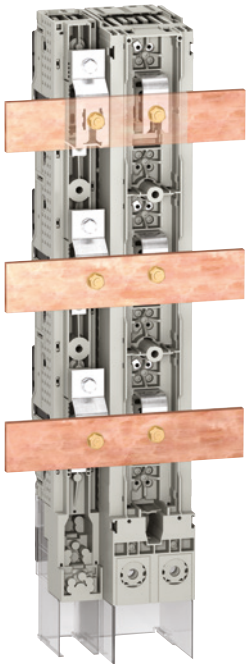

Direct connection on 185 mm busbar (ISFL160 with ISFL630)

B

ISFL160 fusegear devices with hook-on connection to 60 mm bars are available in two versions:

- Connection using M8 screws
- Connection using a 95 mm² terminal.

For each of these versions, the distribution reversal mode is achieved by rotating the hooks located at the rear, which gives the possibility of upstream distribution. The fuse-carrier assembly does not change position. All the various connection modes could be reversed also.

ISFL160 fusegear with turnable hooks [1]

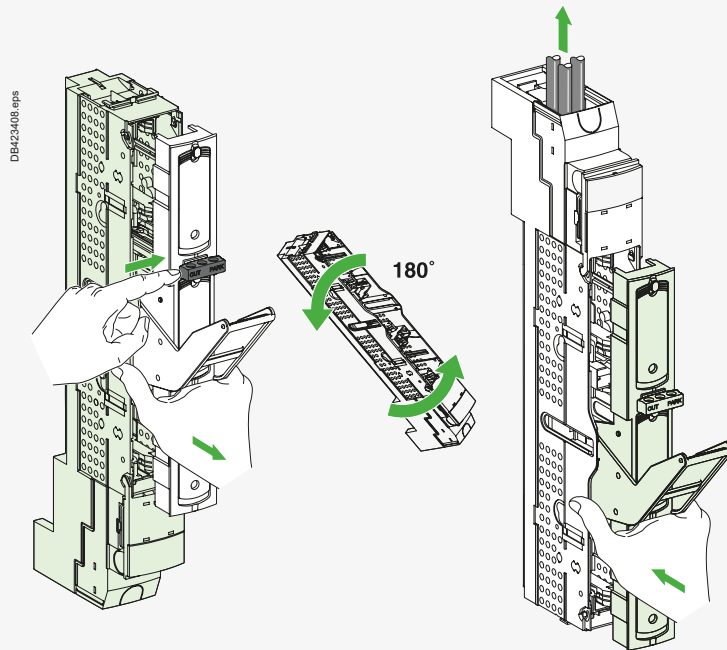

ISFL250/400/630 fusegear [1]

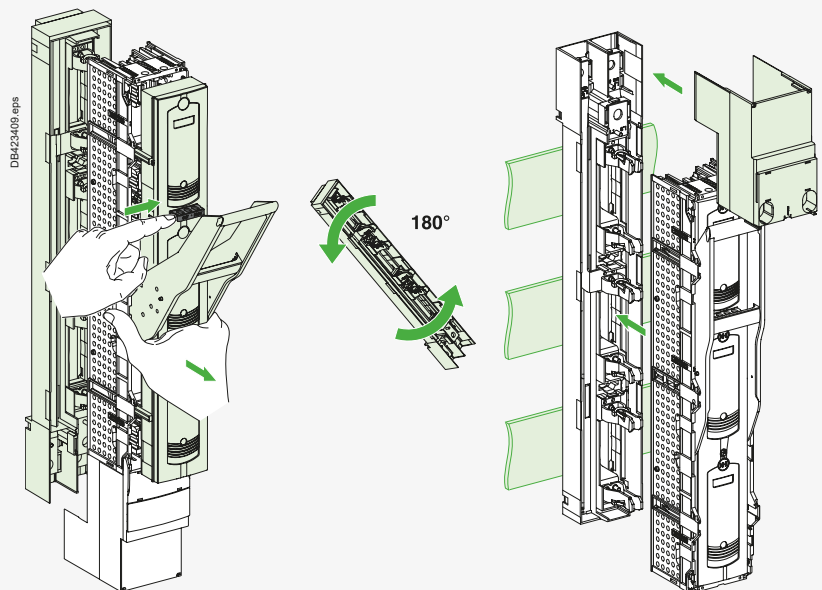

ISFL160 release tab

- To remove the fuse-carrier assembly from the base, put the device in open position and press the release tab down.
- To lock the fuse-carrier assembly, replace it in open (OFF) position on the base and push the release tab up.

ISFL250/400/630 release tab

- To remove the fuse-carrier assembly from the base or install it on the base, check that the device is in open position and press the release tab down.
- To lock the device in open (OFF) position, push the release tab up.

[1] For ISFL 1-pole switchable: identical reversed distribution could be done.

Connection and accessories

FuPacT ISFL1250 - Reverse distribution

ISFL1250 fusegear devices can be reversed to allow an upstream distribution.

ISFL1250 fusegear

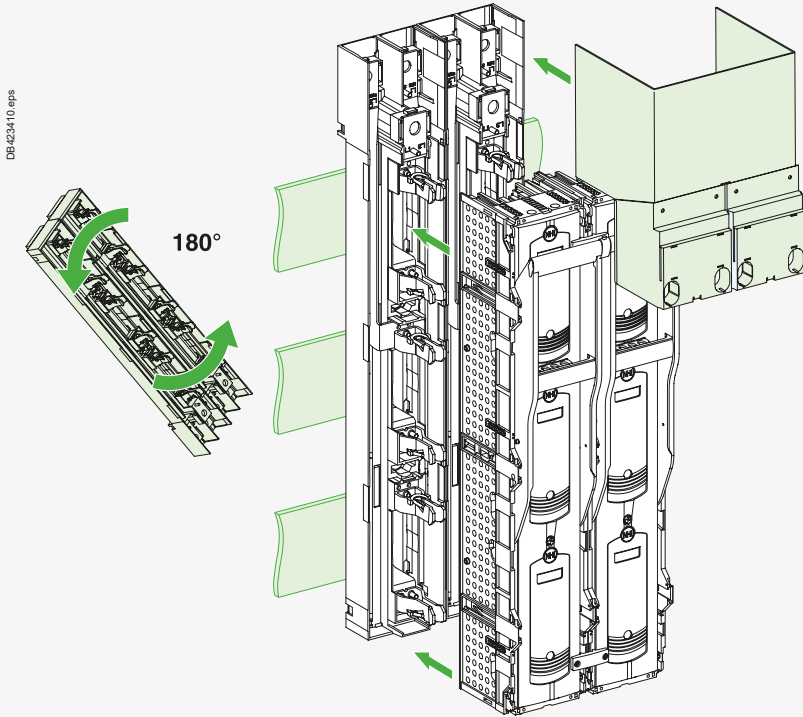

B

Insulation

FuPacT ISFL160 to ISFL630

B



Length adapter



Sideframe door cut out



Sidewise angle bracket for side frame

ISFL160 fusegear

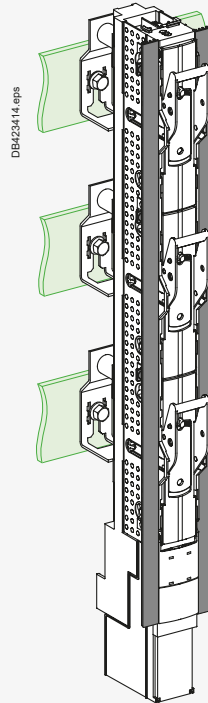
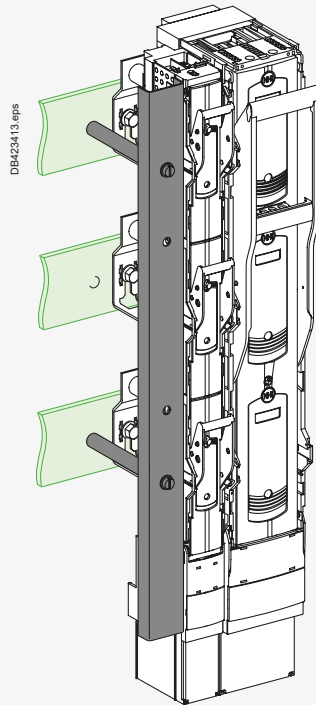
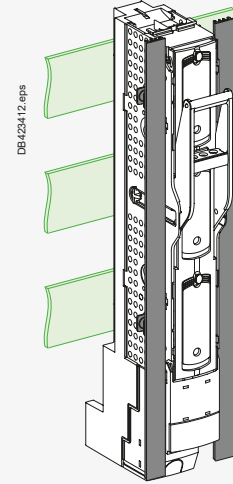
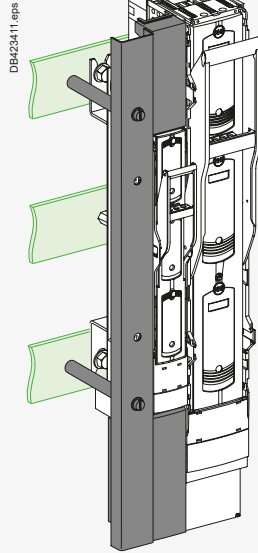

Insulation

FuPacT ISFL250 to ISFL1250

ISFL250/400/630 fusegear^[1]

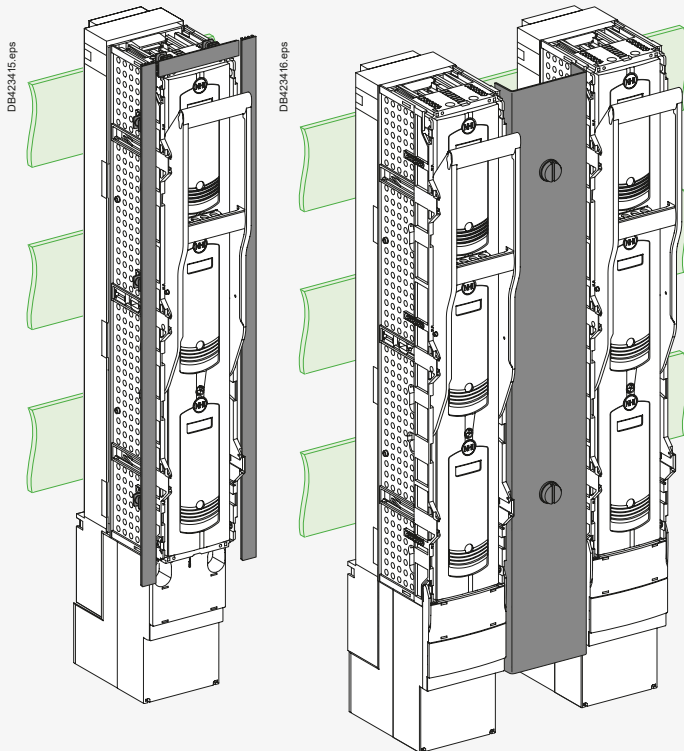

Blank panel cover

[1] Accessories are identical for ISFL 1-pole switchable.

ISFL1250 fusegear

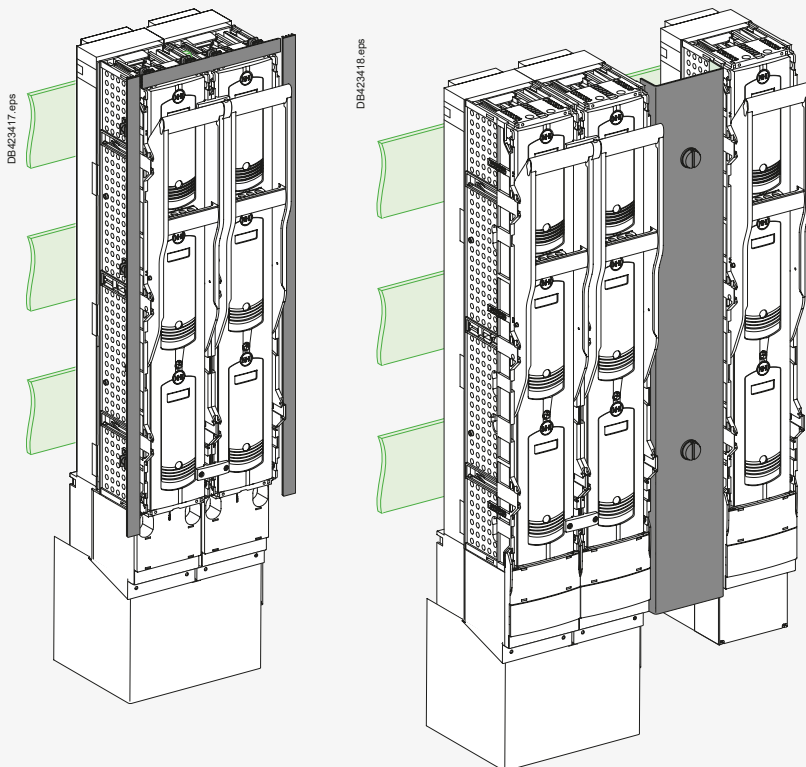

B

Fuse monitor

FuPacT ISFL160 to ISFL1250

PB107276_11.eps



PB107276_20.eps



PB119108.eps



Functions

The device provides remote indication of the standard fuse status (without strikers). It is used to:

- Signal a blown fuse
- Protect motors from overloads caused by single-phase operation.

Standards

- Compliance with international standard IEC 60947-5-1.
- Compliance with:
 - EN 50204
 - EN 61000 for electromagnetic compatibility (EMC).

Description

- Fuse monitor function only for 3P.
- Operation with DIN fuses.
- May be used on capacitor bank circuits.
- Simplified power supply:
 - Does not require a specific power supply
 - Operates with unbalanced phases
 - Supplied via connection to the fuse terminals on the switch-disconnector fuse
 - Operational voltage 400...690 V AC, ±10 %, 50/60 Hz.
- Tested for electromagnetic compatibility (EMC).
- ISFL160:
 - It is a fuse-carrier/handle and fuse monitor sub-assembly supplied as a kit composed of:
 - Fuse monitor equipped with one NO contact and one NC contact
 - Fuse-carrier with the handle
- ISFL250 to 1250:
 - Order directly the fuse monitor mounted on the product
- Characteristics:
 - IP20 degree of protection
 - To have a complete class II insulation, install the product with a fuse monitor inside a switchboard and not on the front face.

Class II insulation with switchboard on front face is ensured only when FuPacT ISFL is in closed position.

Note: lugs for connection to the fuse-carrier are not supplied.

Operation

Reset

The device is automatically reset when the fuse-links are replaced.

Indications

- Normal operation:
 - The green LED is ON when voltage is present at the fuse terminals
 - The contacts are in the rest position
- Operation when a fuse is blown:
 - The green LED goes off and the red LED goes on
 - The contacts are actuated:
 - The NO contact is for remote fault indication
 - The NC contact may be used, for example, to control an undervoltage device in order to shut down equipment that may be sensitive to single-phasing.

Fuse monitor

FuPacT ISFL160 to ISFL1250

B

Electrical characteristics

Power circuit

Rated operational voltage	(Ue)	400 to 690 V AC 50/60 Hz \pm 10 %
Consumption		< 3 VA
Rated frequency		50/60 Hz
Measurement impedance		> 1000 Ω /V
Rated impulse withstand voltage (1.2 / 50 μ s)	(Uimp)	8 kV

Auxiliary contact output terminals

Terminal indications	NO	13 - 14
	NC	21 - 22
Cable capacity	Flexible	\leq 1.5 mm ² Cu
	Rigid	\leq 2.5 mm ² Cu

Output contact characteristics (1NO + 1NC)

Conventional thermal current Ith (A)	5
Rated insulation voltage (V)	250
Minimum load	10 mA at 24 V

Characteristics

Utilisation category (IEC 60947-5-1)		AC		DC	
		AC12	AC15	DC12	DC13
Operational current (A)	24 V	-	3	-	2
	48 V	-	3	-	-
	110 V	-	3	-	-
	220/240 V	-	3	-	-
	250 V	-	3	-	-
	380/415 V	-	-	-	-
	440 V	-	-	-	-
660/690 V	-	-	-	-	
Rated operational voltage / max. breaking voltage (V AC)		250/440			
Breaking capacity (VA)		2000			

General characteristics

Operating temperature range (°C)	-25...+55 (\leq 500 V)	-25...+45 (> 500 V)
Storage and transport temperature range (°C)	-40...+70	
Fuse blowing detection time (s)	< 2	
Overvoltage category / degree of pollution	IEC 60947-1 3	
Dielectric test voltage (between power circuit and output terminals)	5 kV rms / 1 min 50 Hz	

Electromagnetic compatibility - emission

Conducted	EN 55022 Class B
Radiated	EN 55022 Class B
Harmonic currents	EN 61000-3-2 Class A

Electromagnetic compatibility - immunity

Electrostatic discharge (ESD)	EN 61000-4-2 category B level 2/3
Radiated field susceptibility (RF)	EN 61000-4-3 category A level 3
Surge immunity test	EN 61000-4-5 level 4
Conducted low energy susceptibility (EFT)	EN 61000-4-4 category B level 3
Conducted high energy susceptibility (RF)	EN 61000-4-6 category A level 3
Radio-frequency interference (GSM)	ENV 50204 category A

Magnetic field immunity

Continuous	EN 61000-4-8 level 5
------------	----------------------

Mechanical characteristics

Degree of protection	IP20
Weight (fuse monitor alone) (kg)	0.2
Dimensions	

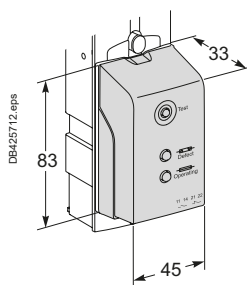

Measurement accessory

FuPacT ISFL160 to ISFL1250

The current transformers (CTs) produce a current (1 - 5 A) on the secondary winding that is proportional to the current measured on the primary winding. They can therefore be used in conjunction with measurement devices (ammeters, energy meters), load-shedding devices, control relays, etc.



Single block current transformer for ISFL160 (1 or 3 CTs)



Current transformer for ISFL160 (1-pole version)

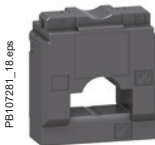

Current transformer for ISFL250/400/630/1250

Altitude correction factor with CT module

2000m	$I_e/I_n = 1$
3000m	$I_e/I_n = 0.98$
4000m	$I_e/I_n = 0.96$
5000m	$I_e/I_n = 0.94$

Diversity factor with CT module

number of main circuit	rated diversity factor
2 and 3	0.9
4 and 5	0.8
6 to 9 inclusive	0.7
10 (and more)	0.6

Ambient derating factor with CT module

ambient temperature	de-rating factor
40°C	1.0
45°C	0.95
50°C	0.9
55°C	0.85
60°C	0.8
65°C	0.75
70°C	0.7

Operation and implementation

FuPacT ISFL160 to 1250 fusegear can be equipped with tube-unit current transformers (CT).

CT modules are available in two versions:

- 3-pole module with one or three CTs for ISFL160 fusegear (3-pole version), 1 rating 150 A.
- Single-pole module with one CT for ISFL160 (1-pole version) /250/400/630/1250.
- Fusegear, 4 ratings from 150 to 600 A.

The CT modules are clipped onto the back of the switchgear.

The modules can be connected:

- Via terminal blocks for the 3-pole modules (ISFL160) with output current of 1 A.
- Via cables directly connected with output current of 5 A.
- Via lugs for the single-pole modules (ISFL 160 (1 pole version)/250/400/630/1250).

Selection table

ISFL160 class 1 1-pole version

$I_p/5$	$I_p/1$	Power (VA)
150/5	-	5

ISFL160 accuracy class 1 3-pole version

$I_p/5$	$I_p/1$	Power (VA)
150/5	-	1.5
	150/1	2.5

ISFL250 to 1250 class 1 1 and 3-pole version

$I_p/5$	Power (VA)
150/5	2.5
250/5	5
400/5	5
600/5	5

Environment

- Compliance with standards: IEC 60044-1, NFC 42502, VDE 0414, BS 7626 and IEC 60038-1.
- Degree of protection: IP20.
- Operating temperature range: -25 °C to +70 °C, relative humidity 95 %.
- Storage temperature range: -40 °C to +80 °C.

Technical characteristics

CT electrical characteristics:

- Maximum operational voltage: 800 V
- Secondary current: 5 A and 1 A
- Frequency: 50 to 60 Hz
- Continuous overload current: 1.2 I_n
- Safety factor: $F_s \leq 5$.

Transformation ratio:

- $I_p/5$ A.

Select the ratio just above the measured current (I_n).

Example: $I_n = 550$ A → select a ratio of 600/5.

CT accuracy class:

- The accuracy class depends on the transformer rating and the consumption of the measurement system. Consumption must take into account the devices and cables
- For a given accuracy class, measurement system consumption must not exceed the transformer rating.

Reminder:

Transformer secondary must be short-circuited before any work.

Measurement accessory FuPacT ISFL160 to ISFL1250

CT accuracy class

Measurement system	
Schneider Electric device	Consumption in VA
72 x 72 mm ammeter	1.1
Analogue ammeter	1.1
Digital IM ammeter	0.5
Digital ammeter	0.3
PM/CM Power Meter	0.15
PM9	0.55

Primary copper cross-section in mm ²	Rating in VA per meter of double wire at 20 °C
1	1
1.5	0.685
2.5	0.41
4	0.254
6	0.169
10	0.0975

For each ten-degree increase in temperature, the power drawn by the cables increases by 4 %.

Example of measurement system consumption at 40 °C

4 m of 2.5 mm ² double wire	1.7 VA
PM	+ 0.15 VA
Total consumption	= 1.85 VA

CT accuracy class

The accuracy class of the CT is determined:

- Using the selection table
- By the fact that consumption must be < the transformer rating:
 - Class 1 for a CT with a ratio of 150/5
 - Class 0.5 for a CT with a ratio of 200/5.

If measurement accuracy must be within 0.5 %, it is necessary to select a CT with a transformation ratio of 200/5.

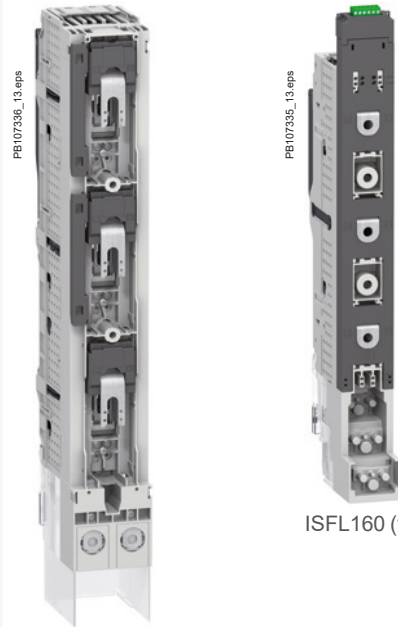

ISFL250/400/630 (with CT)



ISFL250 (with CT)



Fuse-link monitoring and testing

FuPacT ISFL160 to ISFL1250

B

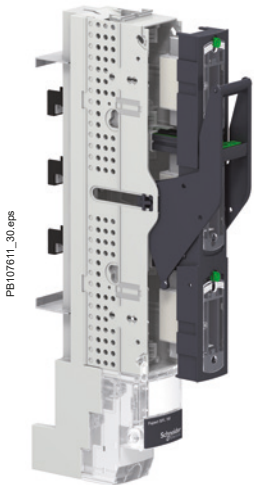

PB107611_30_eps

ISFL160

Monitoring

ISFL fuse-switch disconnecters are equipped with large windows so that the fuse-link technical characteristics are clearly visible.

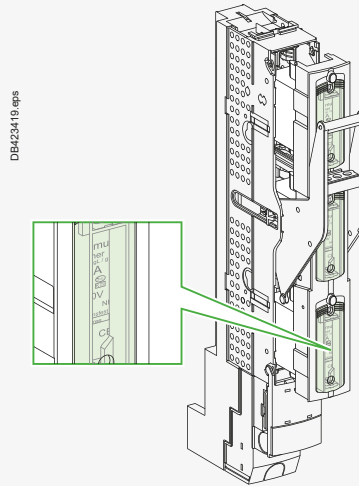

DB423419_eps

Testing

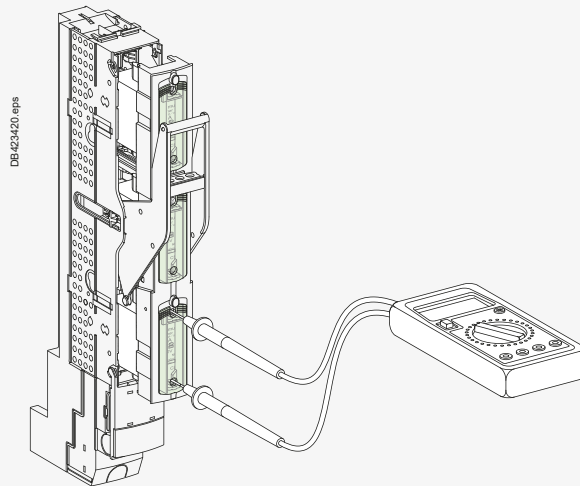

DB423420_eps

Sliding covers on the front panel provide access to the fuse-link status test points while maintaining the IP20 protection index.

Note: monitoring and testing functions are the same for ISFL 1 pole switchable.

Control, locking and operation

FuPacT ISFL160 to ISFL1250

The main moving contacts are controlled by the drawout fuse-carrier assembly for the ISFL devices. In open position, the fuse-switch disconnecter fuse-carrier assembly provides isolation with visible break.

Control

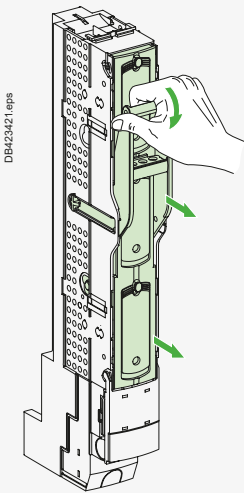

Removed sub-assembly [1]

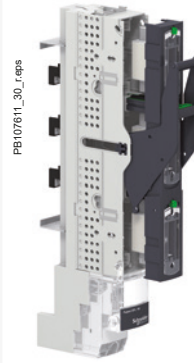
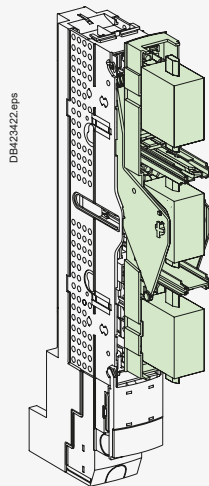

ISFL160

To indicate isolation at a glance during maintenance operations for example, put the ISFL fuse switch-disconnector in the "PARK" position by pressing the lock on the front of the **product**.

In this position, the handle is free and the fuses are physically separated from the contacts.

The **product** can then be padlocked (3 x Ø6 mm padlocks for ISFL160 and Ø8 mm for other ISFL).

Press the lock again to close the product when the padlocks have been removed. Another solution is to remove the upper sub-assembly by pressing the lock in the "OUT" position. **Then**, the sub-assembly must be reversed and put directly on the product.

Access to the fuse-links:

- Is automatically blocked on the ISFL devices when the fusegear is closed
- May be restricted using padlocks on the ISFL devices.

To lock the fuse-switch disconnecter in closed (ON) or open (OFF) position, the fuse-carrier is equipped with lead-seal or padlocking accessories (not supplied).

Locking ON [2]



Locking OFF [2]

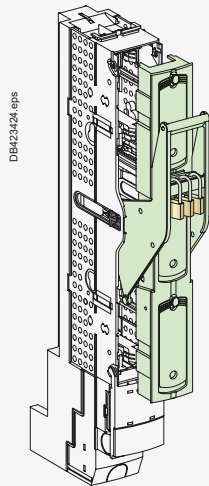
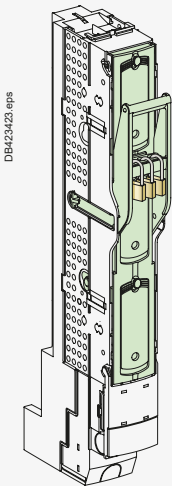
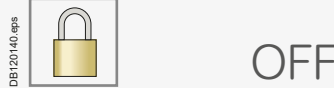

Padlocking for the ISFL160 to ISFL630 devices

[2] Except for ISFL160 - 1P to ISFL630 - 1P.

Locking in open (OFF) position provides isolation as defined by IEC 60947-3.

Type	Function	Means	Accessory
ISFL160	Device locking in closed (ON) or open (OFF) position	Padlocks 3 max Ø6	Built-in
ISFL250 to ISFL1250		Padlocks 3 max Ø8	



Control, locking and operation

FuPacT ISFL160 to ISFL1250

For FuPacT ISFL fusegear devices, the fuse-carrier assembly is used both to control the device and to mechanically protect the fuse-link.

B

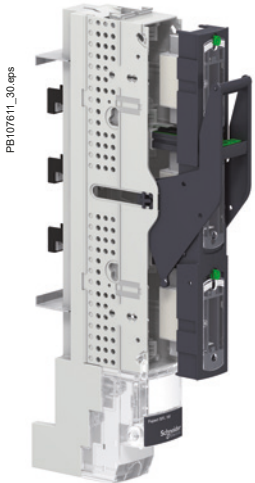

ISFL160

Fuse-carriers ^[1]

Compatibility between ISFL fuse-switch disconnectors and fuse-links (NH)

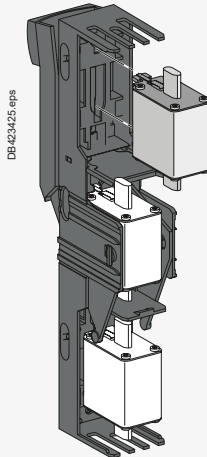

Drawout fuse-carrier assembly for the ISFL 160 to 1250 devices

Type of DIN fuse-link	NH000	NH00	NH1	NH2	NH3
ISFL160	●	●	-	-	-
ISFL250	-	-	●	-	-
ISFL400	-	-	-	●	-
ISFL630	-	-	-	-	●
ISFL1250	-	-	-	-	●

Insertion and removal of fuse-links

Fuse-links are held in place by clips behind the front panel of the fuse-carriers, thus making removal possible without touching the fuse-links.

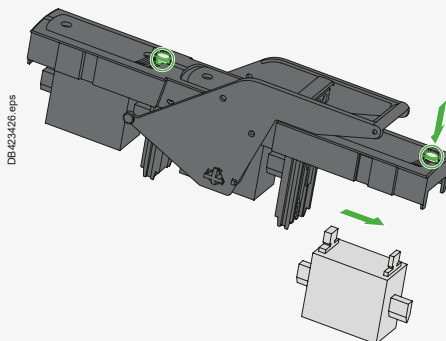

ISFL 160 and ISFL250 to ISFL1250

[1] Control, locking and operation are the same for ISFL 1-pole switchable.

Auxiliary contacts and indications

FuPacT ISFL160 to ISFL1250

The optional auxiliary contacts carry out indication functions. They provide remote indication of the fuse-switch disconnecter status. They may also be used to indicate and carry out automatic functions such as electrical interlocking.

Standards: compliance with international recommendation IEC60947-5-1.
Description: NC/NO changeover contact.

Functional table of contact status

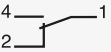
Auxiliary changeover contact		
		Maximum number
ISFL160		2
ISFL250		4
ISFL400		4
ISFL630		4
ISFL1250		8

Auxiliary changeover contact for ISFL160 to 1250			
Rated thermal current I _{th} (A)	2		
Rated insulation voltage (V)	250		
Minimum load	100 mA at 24 V		
		AC12	DC12
Operational current (A)	24 V	2	0.2
	48 V	2	0.2
	110 V	2	0.2
	220/240 V	2	0.2

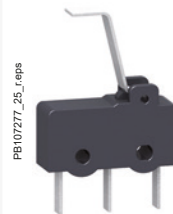

Auxiliary contact for ISFL160

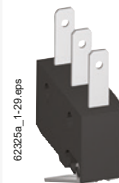

ISFL250/400/630/1250



Auxiliary contacts and indications

FuPacT ISFL160 to ISFL630

B

PB107277_25_eps



Auxiliary contact for ISFL160

6325a_1_25_eps



ISFL250/400/630/1250

Position of auxiliary contacts for ISFL devices

ISFL160

ISFL250/400/630

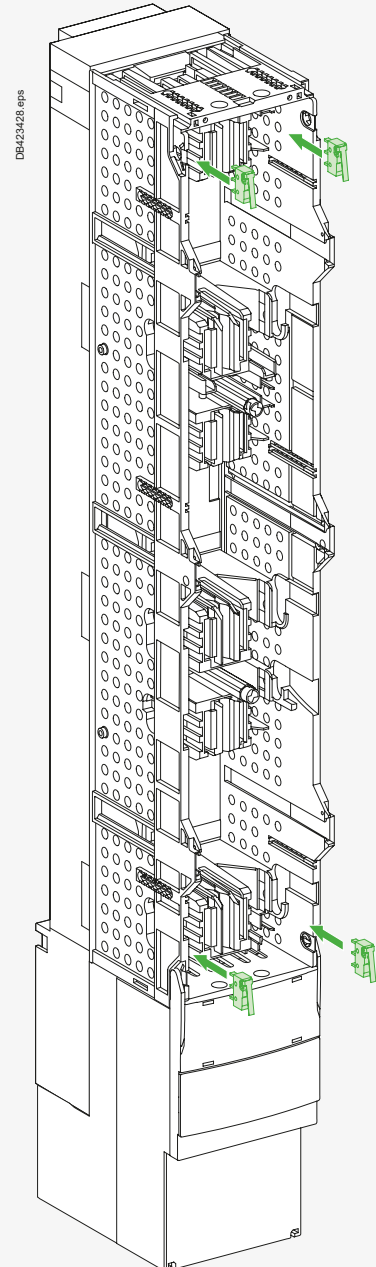
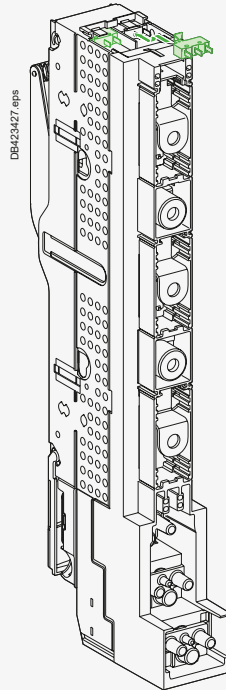

Auxiliary contacts and indications

FuPacT ISFL1250

Position of auxiliary contacts for ISFL devices

ISFL1250

DB423429.eps

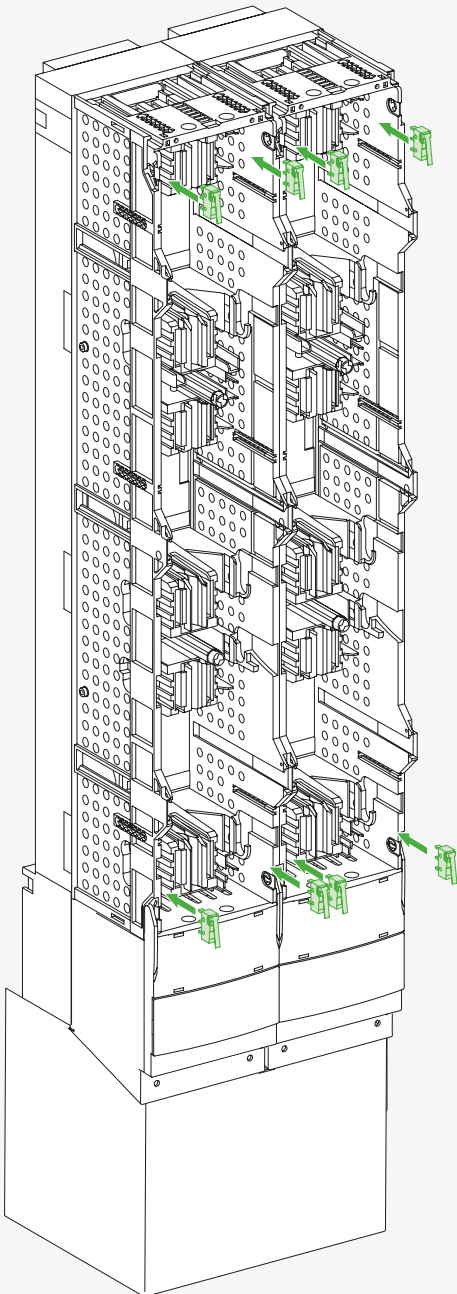

62325a_1-29.eps



ISFL250/400/630/1250



Intelligent measurement

FuPacT ISFL160 to ISFL630

B



PB104892_eps



PB104891_eps

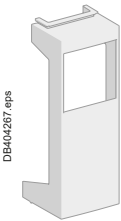

DB404267_eps

Empty plastic box for ISFL160

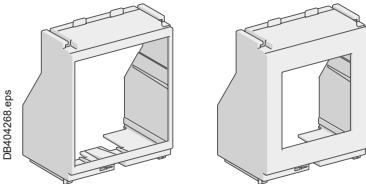

DB404268_eps

Empty plastic box for ISFL250/400/630

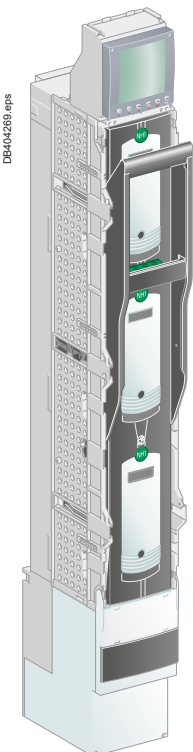

DB404269_eps

ISFL250-630 + Empty box with power meter

The future belongs to more intelligent switchboards. The new ISFL generation, vertical design, are well prepared for the future: they offer standardized interfaces for all types of measurement devices.

Schneider Electric is offering a complete and large offer of metering devices: PowerLogic range.

PowerLogic series meter - Power Meter

The Power Meter serie offers many high-performance capabilities needed to meter and monitor an electrical installation in a compact unit.

All models include an easy-to-read display that presents measurements for all three phases and neutral at the same time, total harmonic distortion (THD) metering, and alarming.

Some models offer an incremental choice of custom logging and power quality analysis capabilities.

Expand any model with field-installable option modules that offer a choice of additional digital inputs and outputs, analog inputs and outputs, and ethernet port.

Flexible measurement options - the amperemeter

Additional measurement options are possible using an amperemeter which is adjusted onto the new amperemeter-bracket. The installation is incredibly simple and the returns extremely versatile.

How to install device

- For ISFL160, you can use an empty box to include measurement device:
 - Plastic box
 - Dimension 46 x 46 mm for the cut-out
 - Length: the same as the length adaptor to be able to put the ISFL160 beside ISFL250 to ISFL630
 - Fixation by mounting it directly to the top of the product.
- For ISFL250 to 630, you can use empty boxes to include measurement devices:
 - Plastic box
 - Dimension 72 x 72 mm and 96 x 96 mm for the cut-out
 - Fixation by mounting it directly to the top of the product.

Possible installation positions and mounting

FuPacT ISFL160 to ISFL1250

Possible installation positions

ISFL160 to 1250

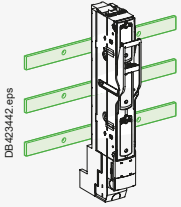

ISFL160 to 630

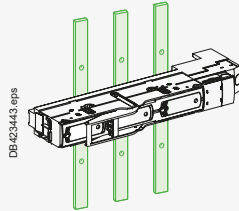

Possible mounting

ISFT100N
ISF●160 to ISF●630
ISFL1250

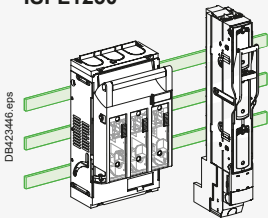

Securely tightened

B

Implementation and power dissipation

FuPacT ISFL

B

Reverse supply

FuPacT fusegear may be supplied equally well via the upstream or downstream terminals, without any reduction in performance.

Conductor materials and electrodynamic forces

FuPacT fusegear may be connected using either bare copper, tinned copper or tinned aluminium conductors (flexible or rigid bars, cables).

In the event of a short-circuit, thermal and electrodynamic forces are exerted on the conductors. The conductors must therefore be adequately sized and suitably supported.

Note that the terminals of electrical devices (switch-disconnectors, contactors, circuit breakers, etc.) should not be considered to contribute to the support of the conductors.

Cable ties and flexible bars

The table below indicates the maximum distances between cable ties depending on the prospective short-circuit current.

Do not to exceed a distance of 400 mm between ties strongly fixed to the switchboard frame.

Type of tie	"Panduit" type			"Sarel" type				
	Width: 4.5 mm Max. load: 22 kg Color: white			Width: 9 mm Max. load: 90 kg Color: black				
Max. distance between ties (mm)	200	100	50	350	200	100	70	50 (double ties)
Short-circuit current (kA rms)	10	15	20	20	27	35	45	100

Note: for cables $\geq 50 \text{ mm}^2$, 9 mm wide ties must be used.

Tightening torque for ISFL with screw connection

	Type	Torque (Nm)
ISFL	ISFL160 1-pole version with direct connection to 185 mm busbars	14
	ISFL160 1-pole version with hook-on connection to 185 mm busbars	14
	ISFL160 3-pole version with direct connection to 100 mm busbars	14
	ISFL160 3-pole version with hook-on connection to 60 mm busbars	6
	ISFL160 3-pole version with direct connection to 185 mm busbars with kit	14
	ISFL160 3-pole version with connectors for flexible bars	4
	ISFL160 3-pole version with connectors for bare Cu/Al cables	4
	ISFL250 1-pole and 3-pole version with direct connection to 185 mm busbars	32
	ISFL400 1-pole and 3-pole version with direct connection to 185 mm busbars	32
	ISFL630 1-pole and 3-pole version with direct connection to 185 mm busbars	32
ISFL1250 3-pole version with direct connection to 185 mm busbars	32	

Implementation and power dissipation

FuPacT ISFL

Power dissipated by ISFL fuse-switch disconnectors

Power dissipated per pole

	Rating (A)	Switchgear Model		Power dissipated per pole (W)	Fuse-link Max. power dissipated		Total Total power dissipated per pole (W)
					Rat. (A)	P (W)	
Device bolted directly to busbars (without conversion kit)	160	ISFL160	1-pole	6.7	160	12	19
			3-pole				
	250	ISFL250	1-pole	9.0	250	32	32
			3-pole				
	400	ISFL400	1-pole	18.7	400	45	53
			3-pole				
630	ISFL630	1-pole	37	630	48	85	
		3-pole					
1250	ISFL1250	3-pole	37	630	48	85	
With conversion kit	160	ISFL160		5.9	160	12	18

B

FuPacT ISFL160 3 x 1P

Dimensions and mounting

Dimensions

Fuse-carrier closed

Front

Open and locked

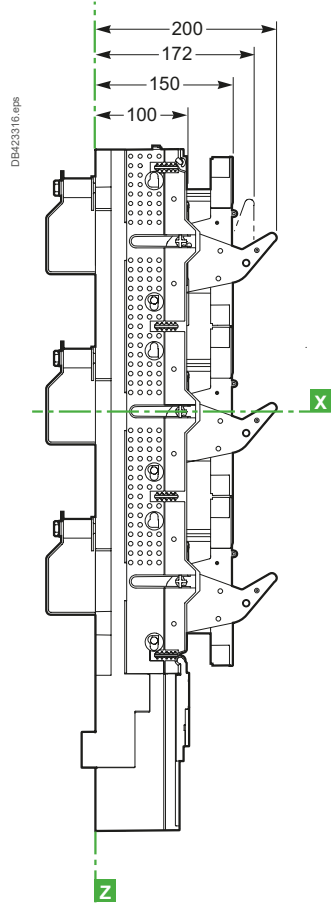
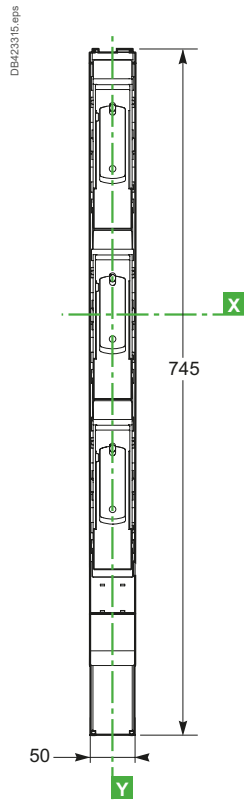
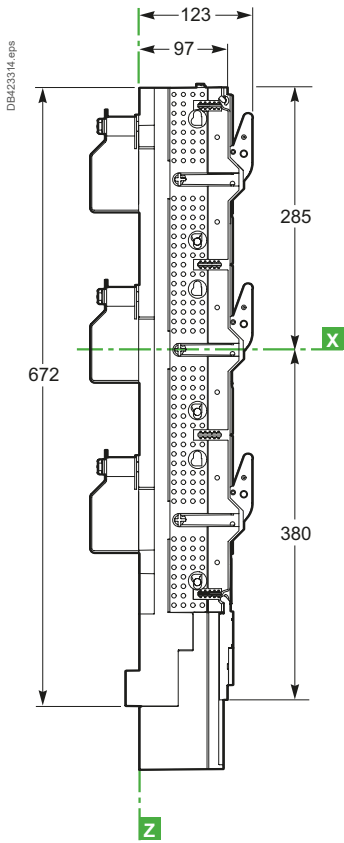

Mounting

For 185 mm busbars

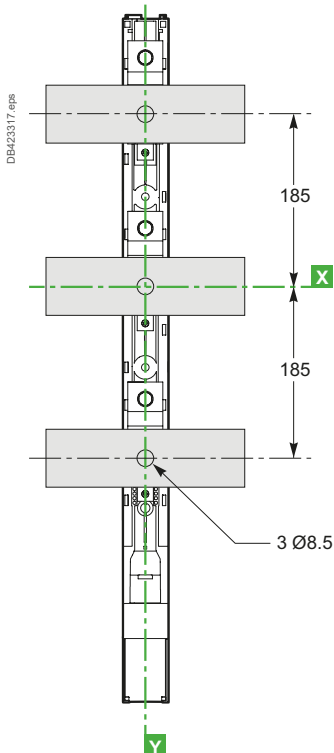

Dimensions and connection

FuPacT ISFL160 3 x 1P

Dimensions and mounting

For 1 device with side cover and/or 1 free slot

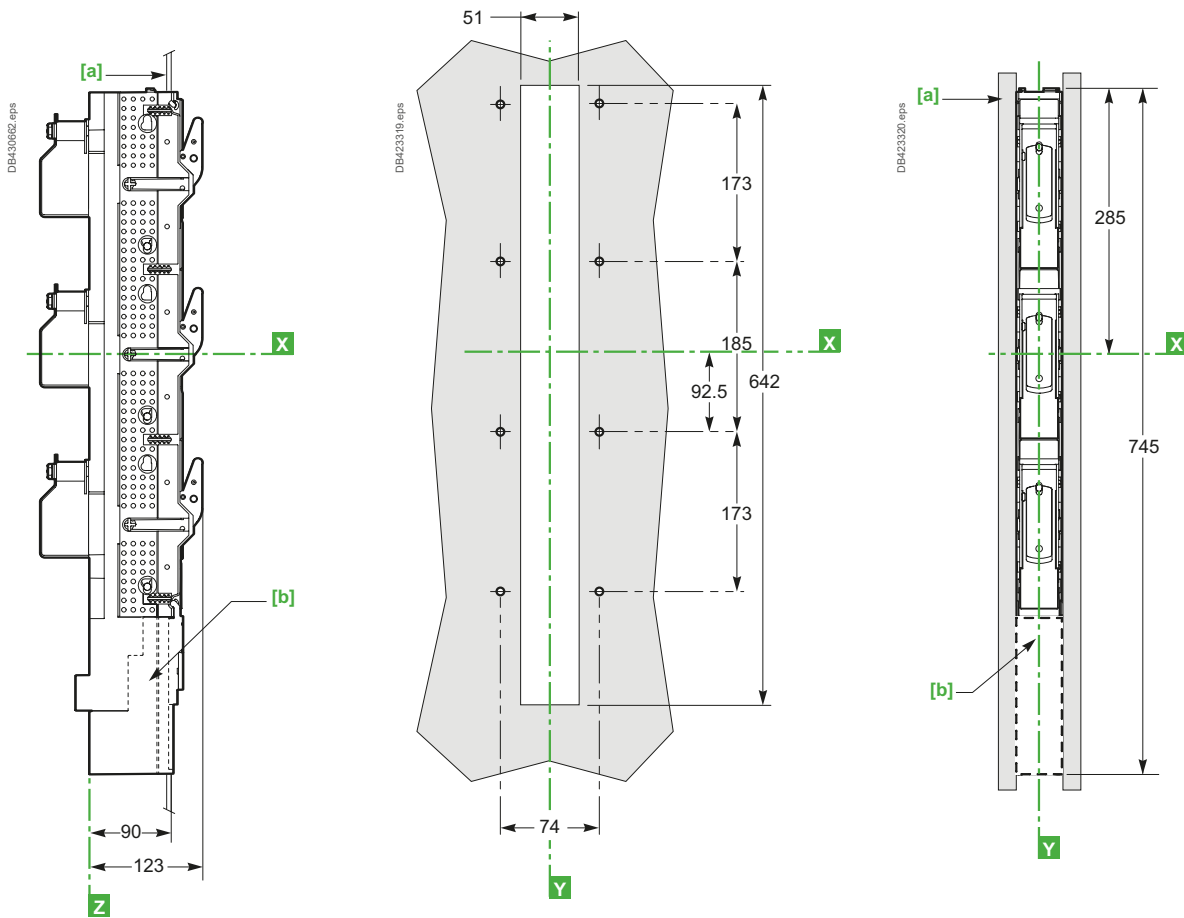

[a] Side cover for front panel cut-out.
 [b] Terminal shields.

B

FuPacT ISFL160 1 x 3P

Dimensions and mounting

Dimensions

Fuse-carrier closed

Front

Open and locked

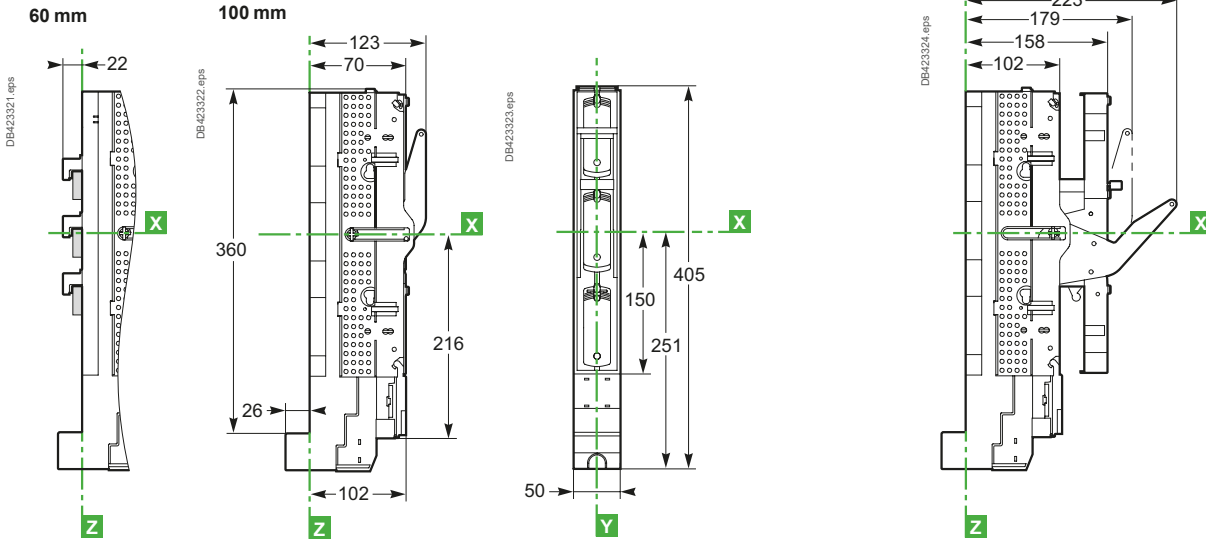

With 185 mm connection kit

With 185 mm connection kit for 2 ISFL devices

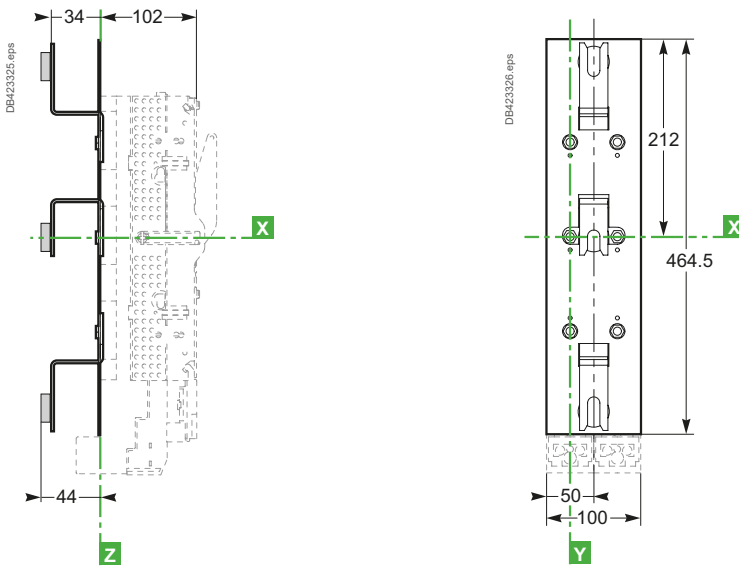

Mounting

For 60 mm busbars

For 100 mm busbars

With connection kit for 185 mm busbars

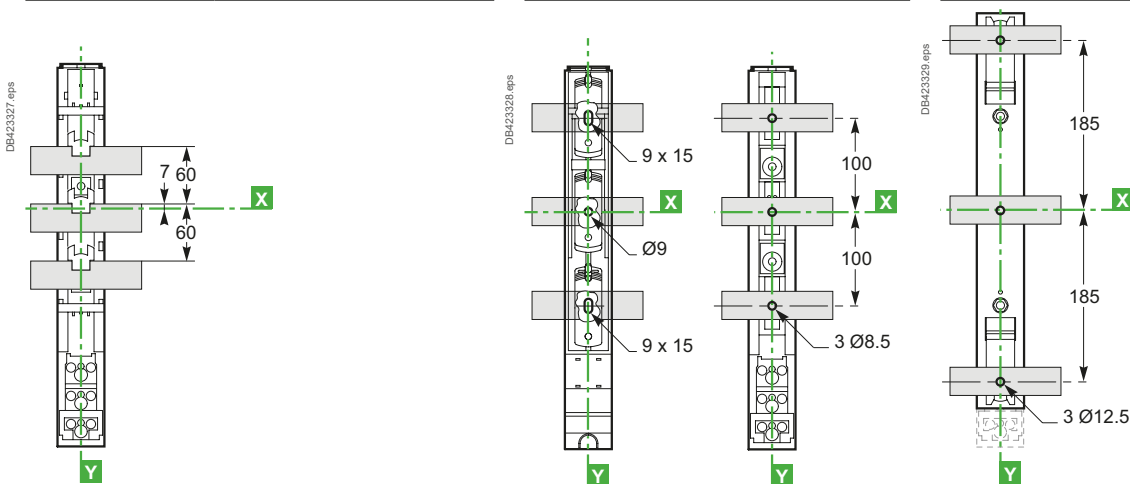

Dimensions and connection

FuPacT ISFL160 1 x 3P

Dimensions and mounting

For 1 device with side cover and/or 1 free slot

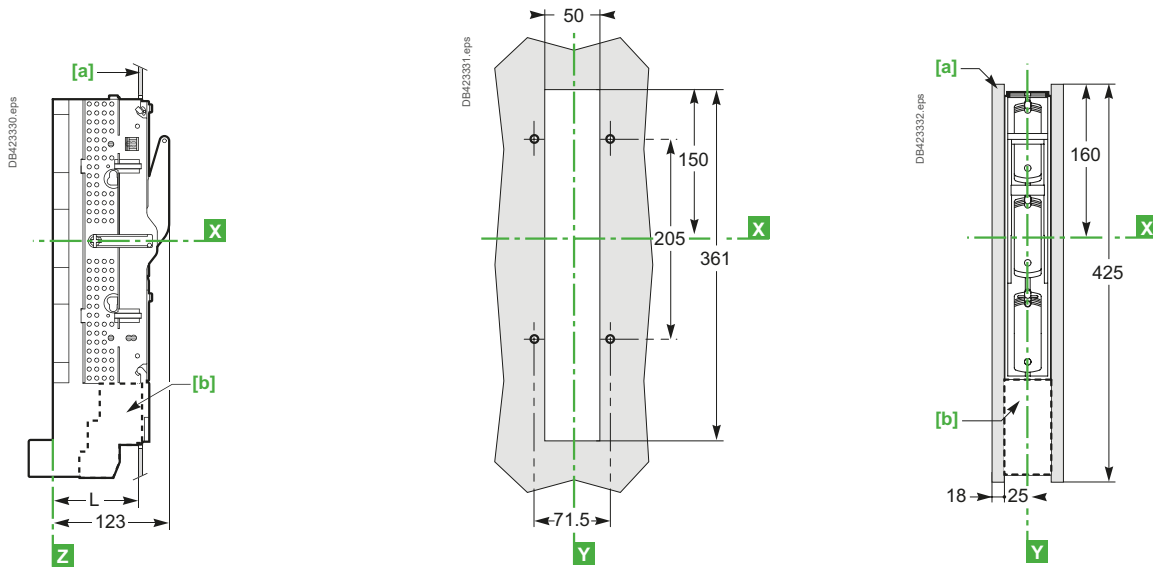

[a] Side cover for front panel cut-out.
[b] Terminal shields.

With length adapter

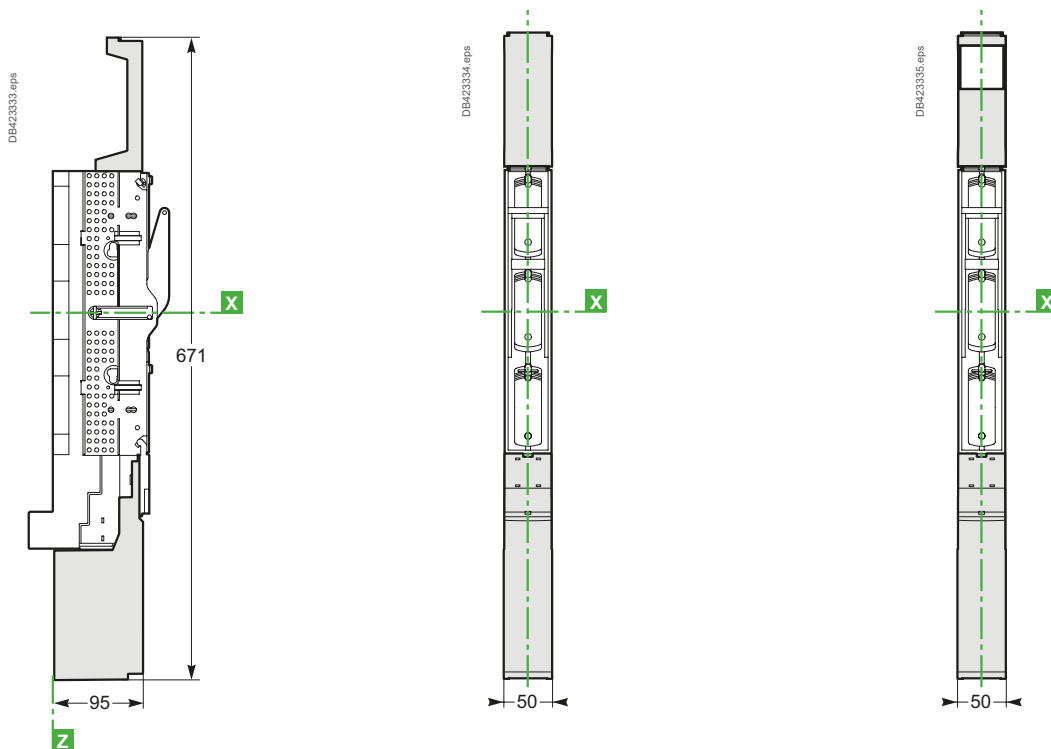

B

FuPacT ISFL160 1 x 3P

Connection and accessories

Connection

Connection via lugs/flexible bars

Connection via connectors

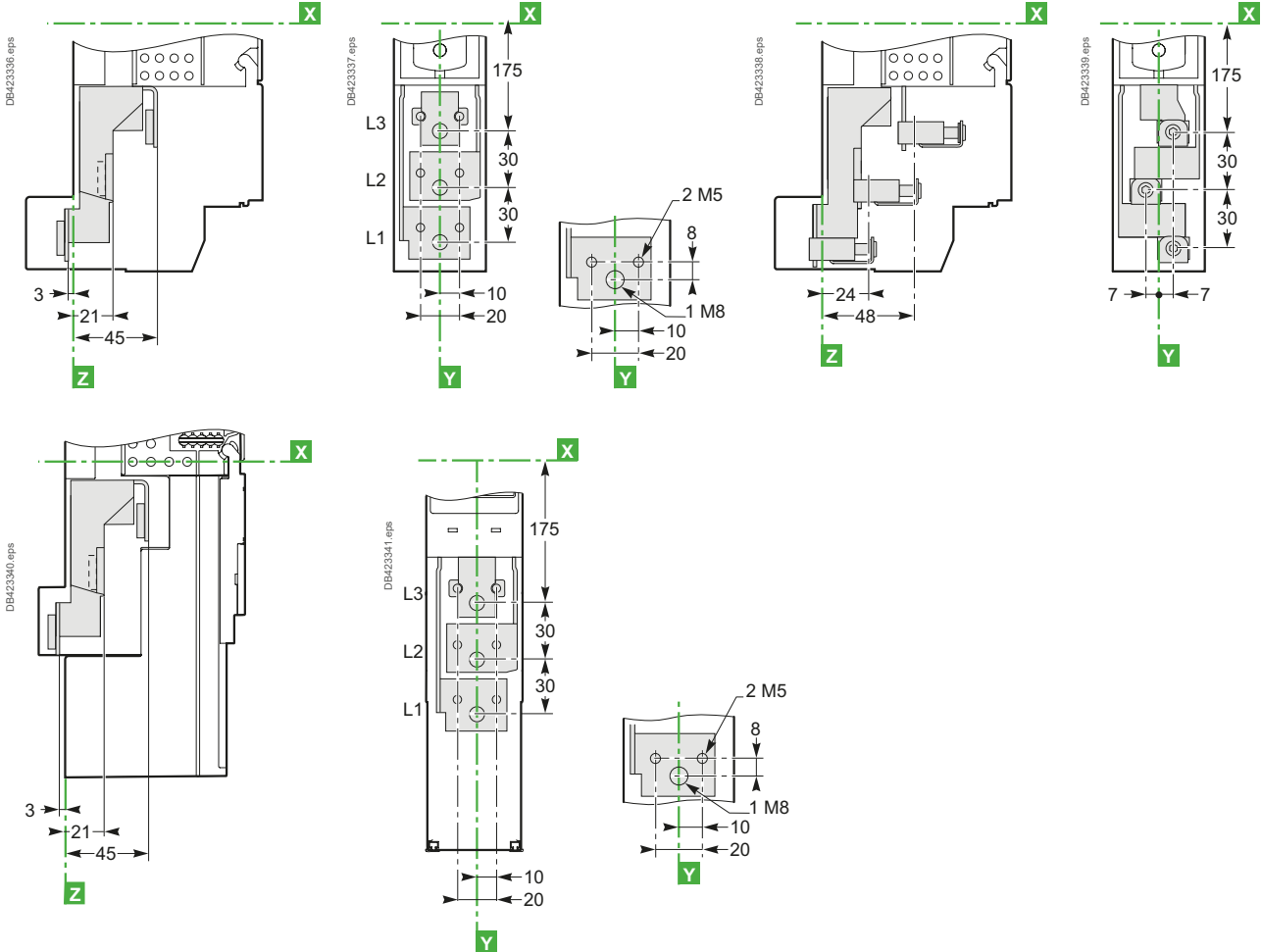

Current transformer

Direct connection to 100 mm busbars

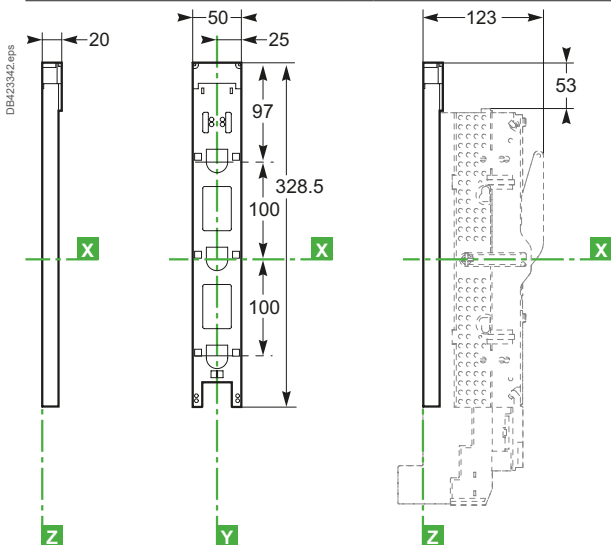

Dimensions and connection

FuPacT ISFL250 to 630 1 x 3P

Dimensions and mounting

Dimensions

Fuse-carrier closed

Front

Open and locked

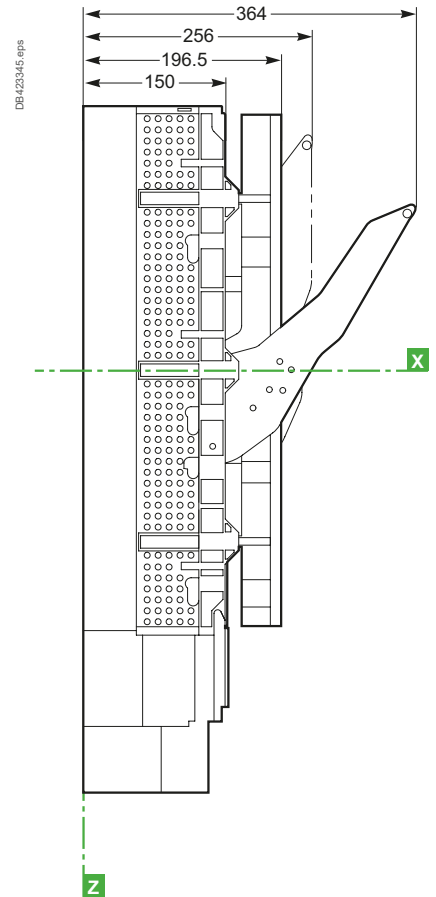
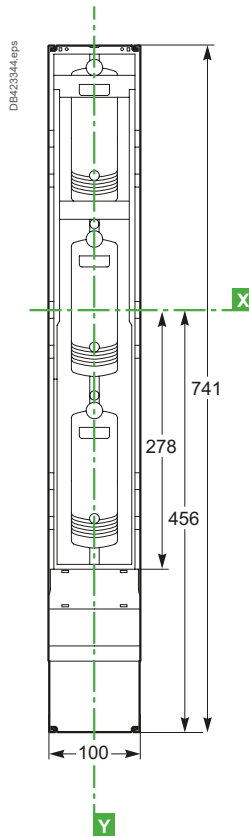
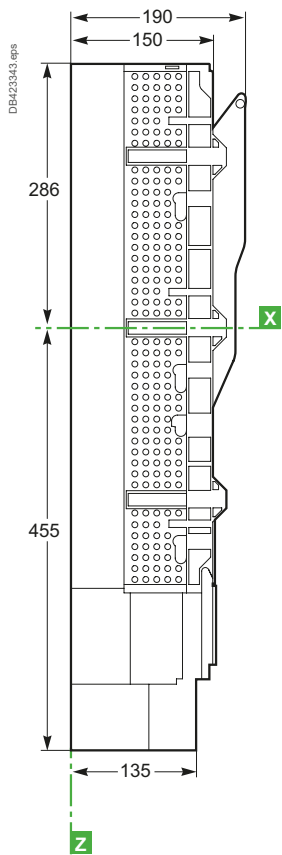

B

Mounting

For 185 mm busbars

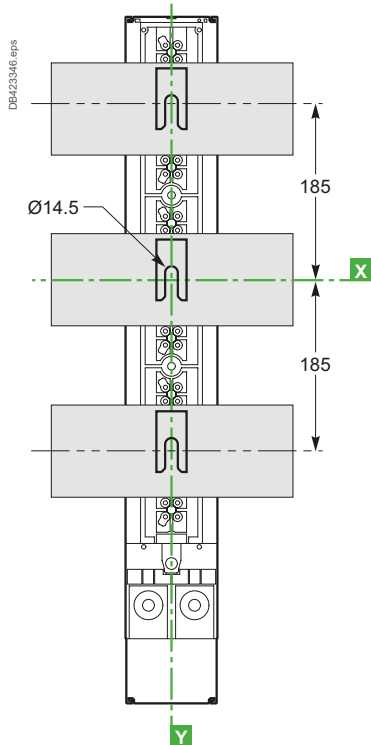

FuPacT ISFL250 to 630

Dimensions and mounting

Device with side cover

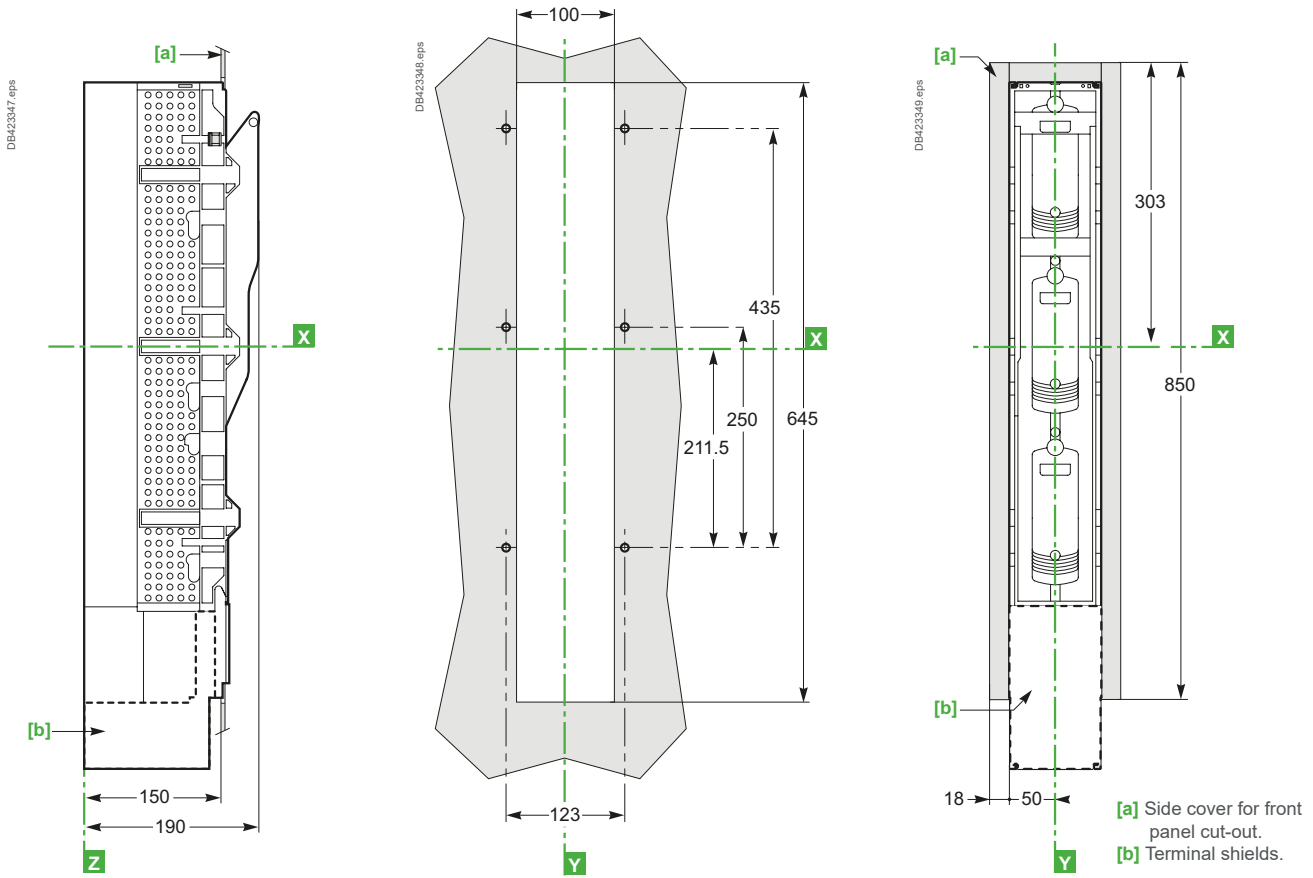

With measurement device

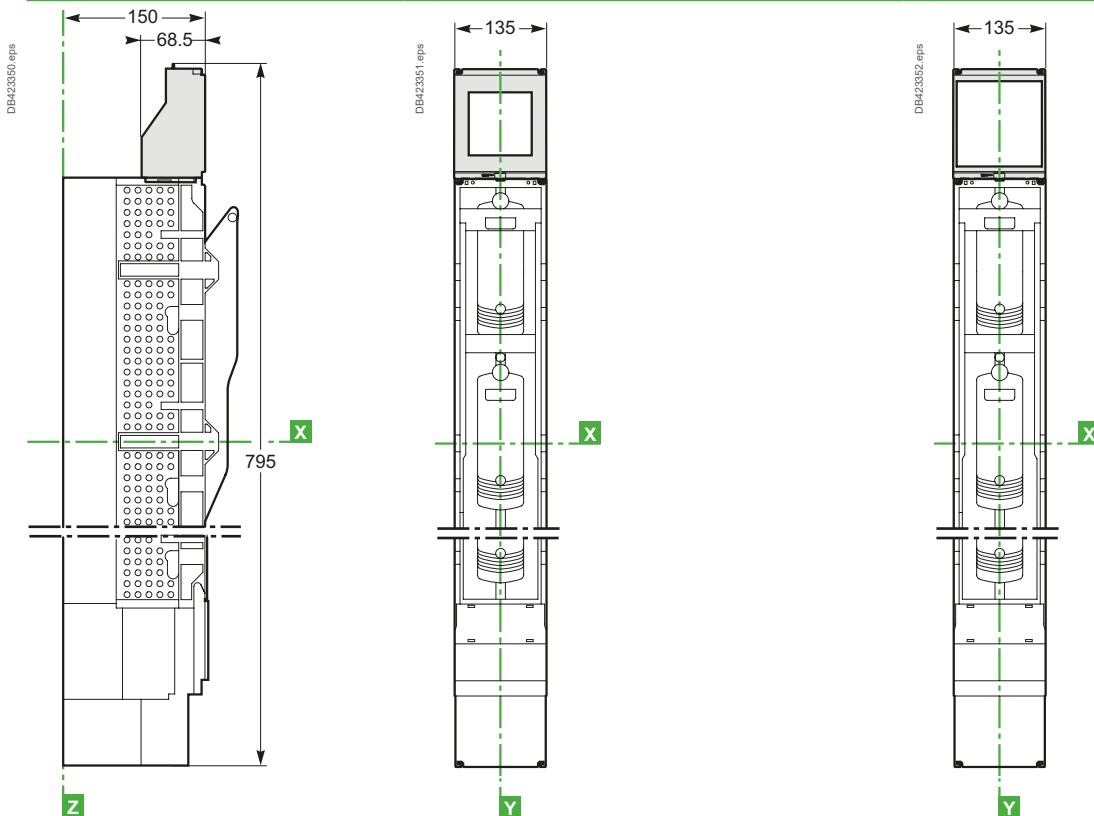

Dimensions and connection

FuPacT ISFL1250

Dimensions and mounting

Dimensions

Fuse-carrier closed

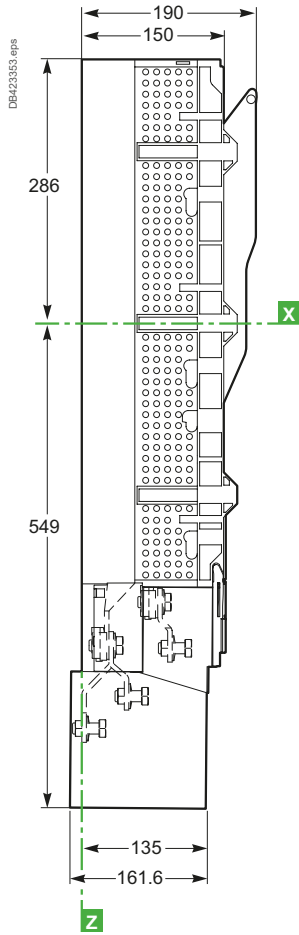

Front

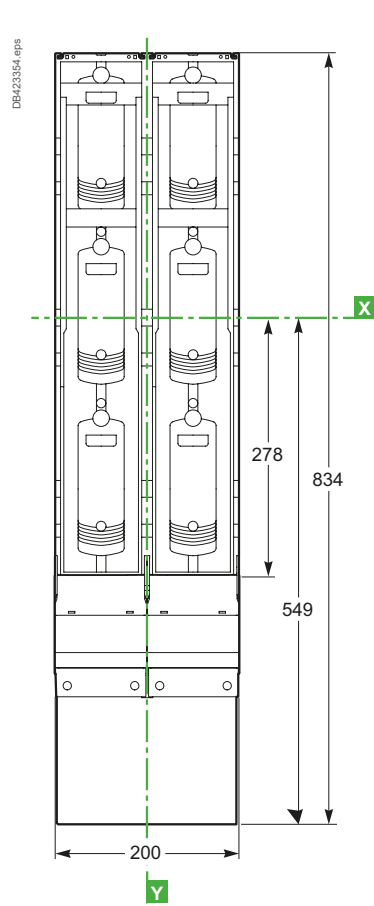

Open and locked

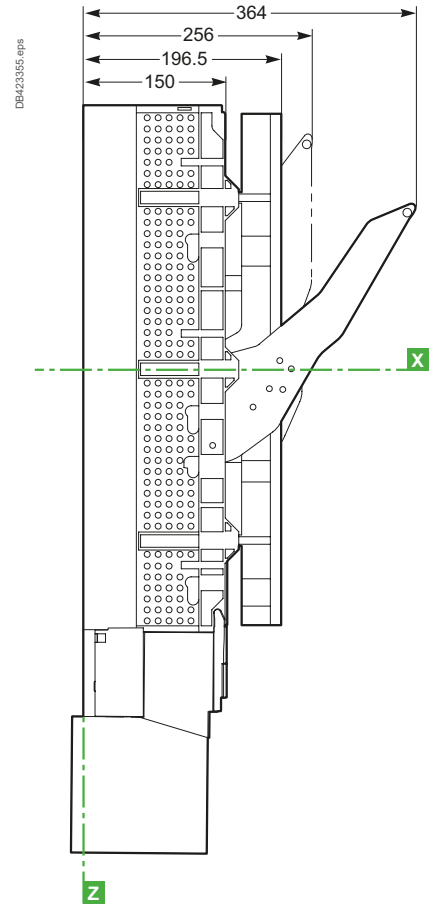

B

Mounting

For 185 mm busbars

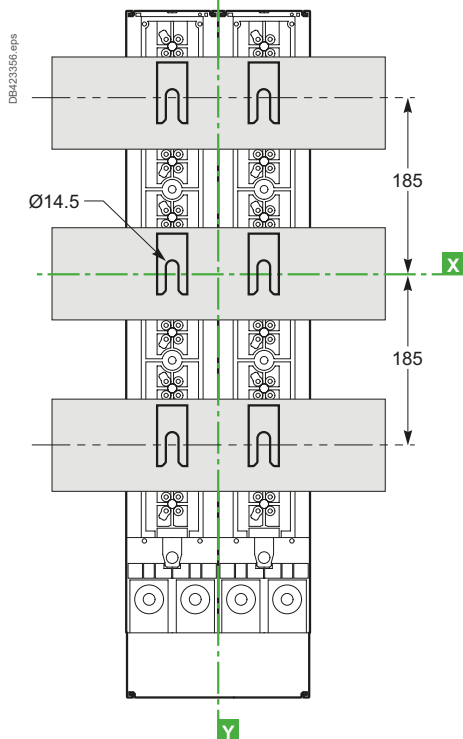

FuPacT ISFL1250

Dimensions and mounting

Device with side cover

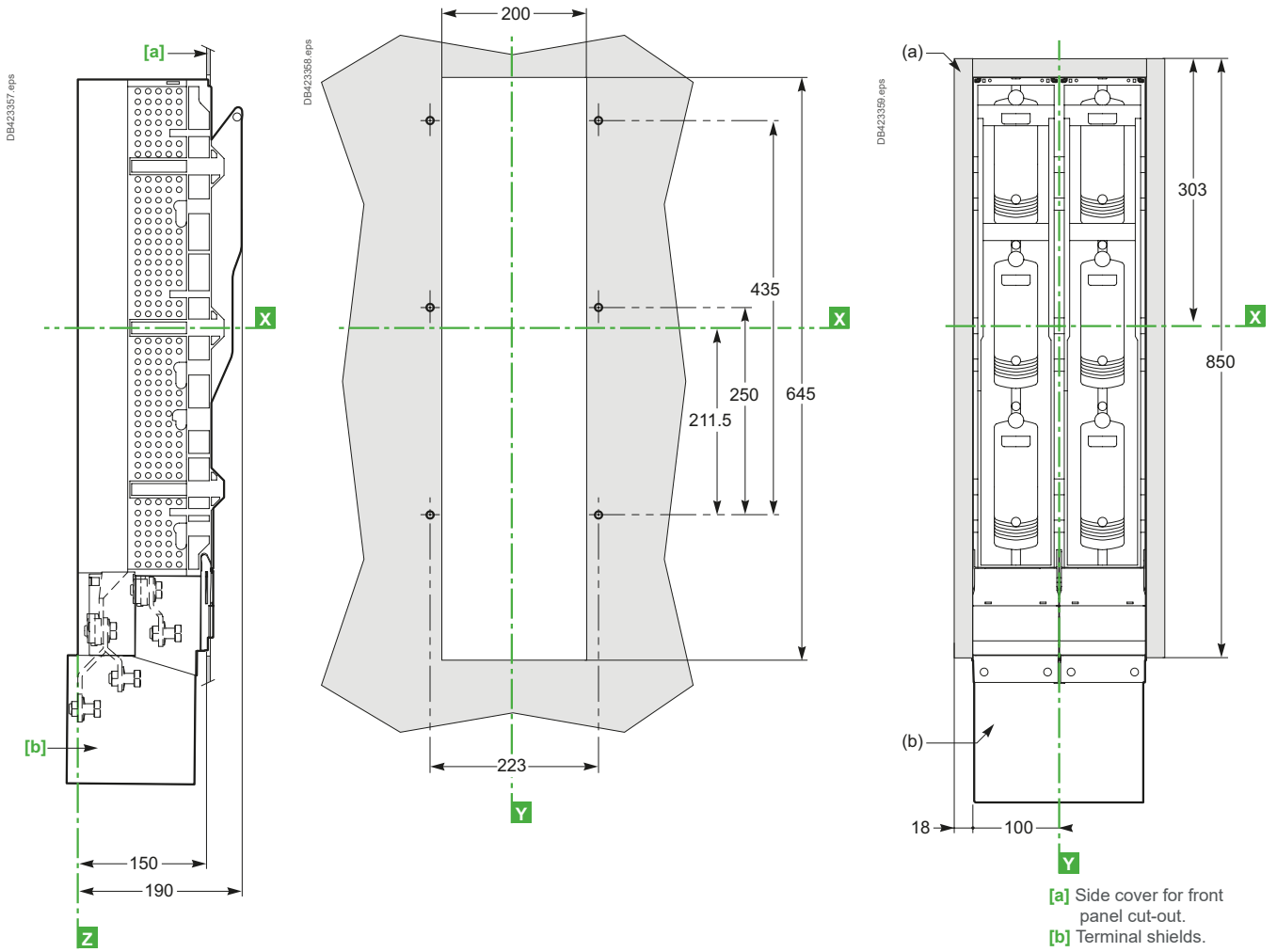

B

Connection

Connection via lugs/flexible bars

Connection via connectors

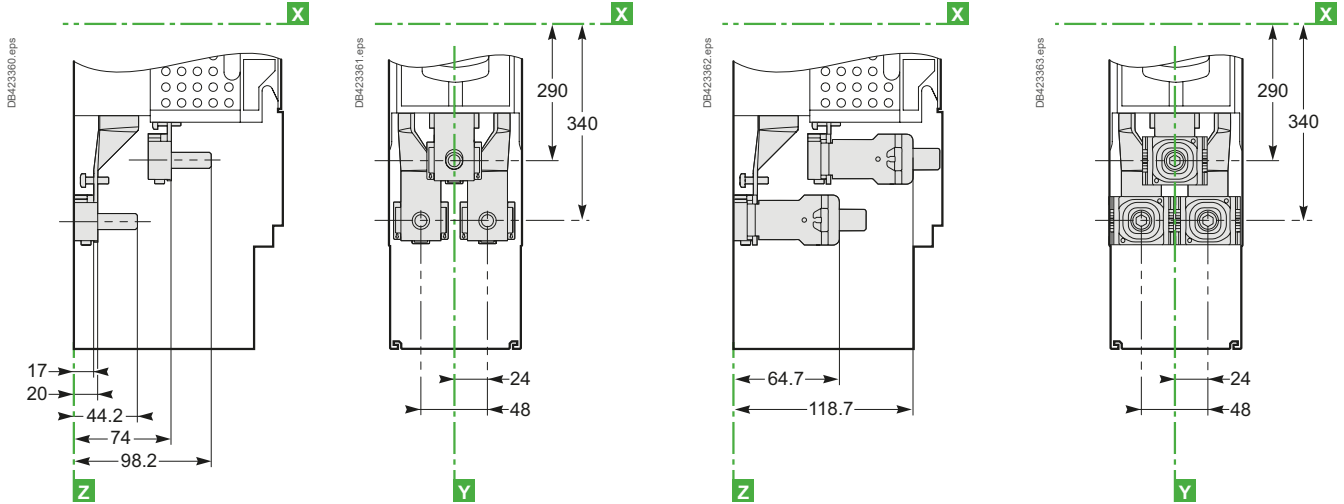

Current transformer

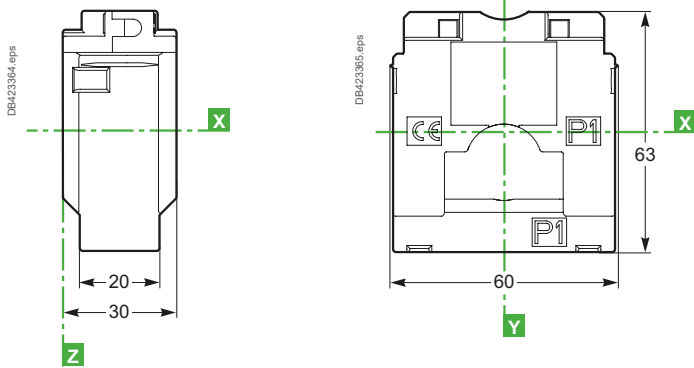

B

Power

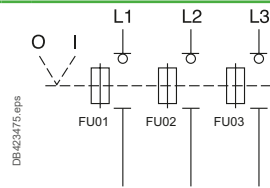

Auxiliary contacts

B

ISFL160

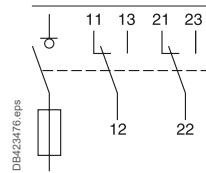

ISFL250 to 630

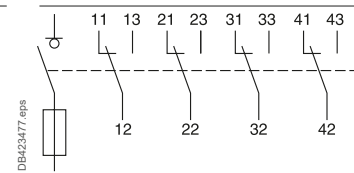

ISFL1250

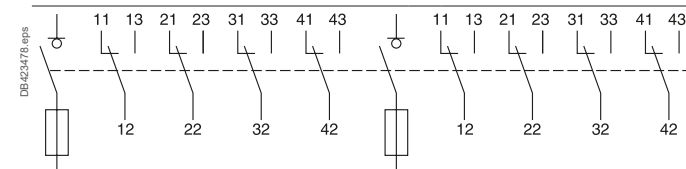

Blown fuse

ISFL160 to 1250 fuse monitor

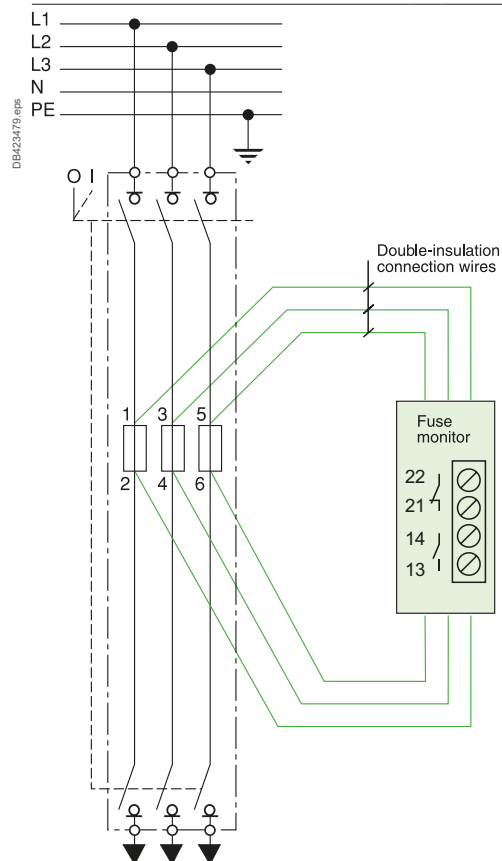

FuPacT GS

Presentation

Offer panorama.....	C-2
FuPacT GS 32 A.....	C-2
FuPacT GS 50/63 A.....	C-3
FuPacT GS 100-160 A.....	C-4
FuPacT GS 200/400 A.....	C-5
FuPacT GS 630/800 A.....	C-6
FuPacT GS 1250 A.....	C-7

Characteristics

IEC switch-disconnector-fuses for use with NFC or DIN fuses.....	C-8
IEC switch-disconnector-fuses for use with BS fuses.....	C-12

Detailed presentation

Presentation of the FuPacT GS range.....	C-16
FuPacT GSB and GSC 32.....	C-16
FuPacT GSC 50, GSB and GSD 63.....	C-18
FuPacT GSB 100, GSC and GSD 125, GSB and GSD 160.....	C-20
FuPacT GSB 200, GSB and GSD 250, GSB and GSD 400.....	C-22
FuPacT GSB and GSD 630, GSB and GSD 800.....	C-24
FuPacT GSB and GSD 1250.....	C-26
FuPacT GSB and GSD 1250.....	C-27

Dimensions and connection

FuPacT GS 32 A.....	C-28
Dimensions.....	C-28
Mounting and front panel cut-outs.....	C-29
FuPacT GS 50/63 A.....	C-30
Dimensions.....	C-30
Mounting and front panel cut-outs.....	C-31
FuPacT GS 100/160 A.....	C-32
Dimensions.....	C-32
Mounting and front panel cut-outs.....	C-33
FuPacT GS 200/400 A.....	C-34
Dimensions.....	C-34
Mounting and front panel cut-outs.....	C-35
FuPacT GS 630/800 A.....	C-36
Dimensions.....	C-36
Mounting and front panel cut-outs.....	C-37
FuPacT GS 1250 A.....	C-38
Dimensions.....	C-38
Mounting and front panel cut-outs.....	C-39
FuPacT GS 32 to 1250 A.....	C-40
Class II installation.....	C-40

Other chapters

Presentation.....	2
FuPacT ISFT.....	A-1
FuPacT ISFL.....	B-1
Catalog numbers.....	D-1



Offer panorama FuPacT GS 32 A

DB496384.ai

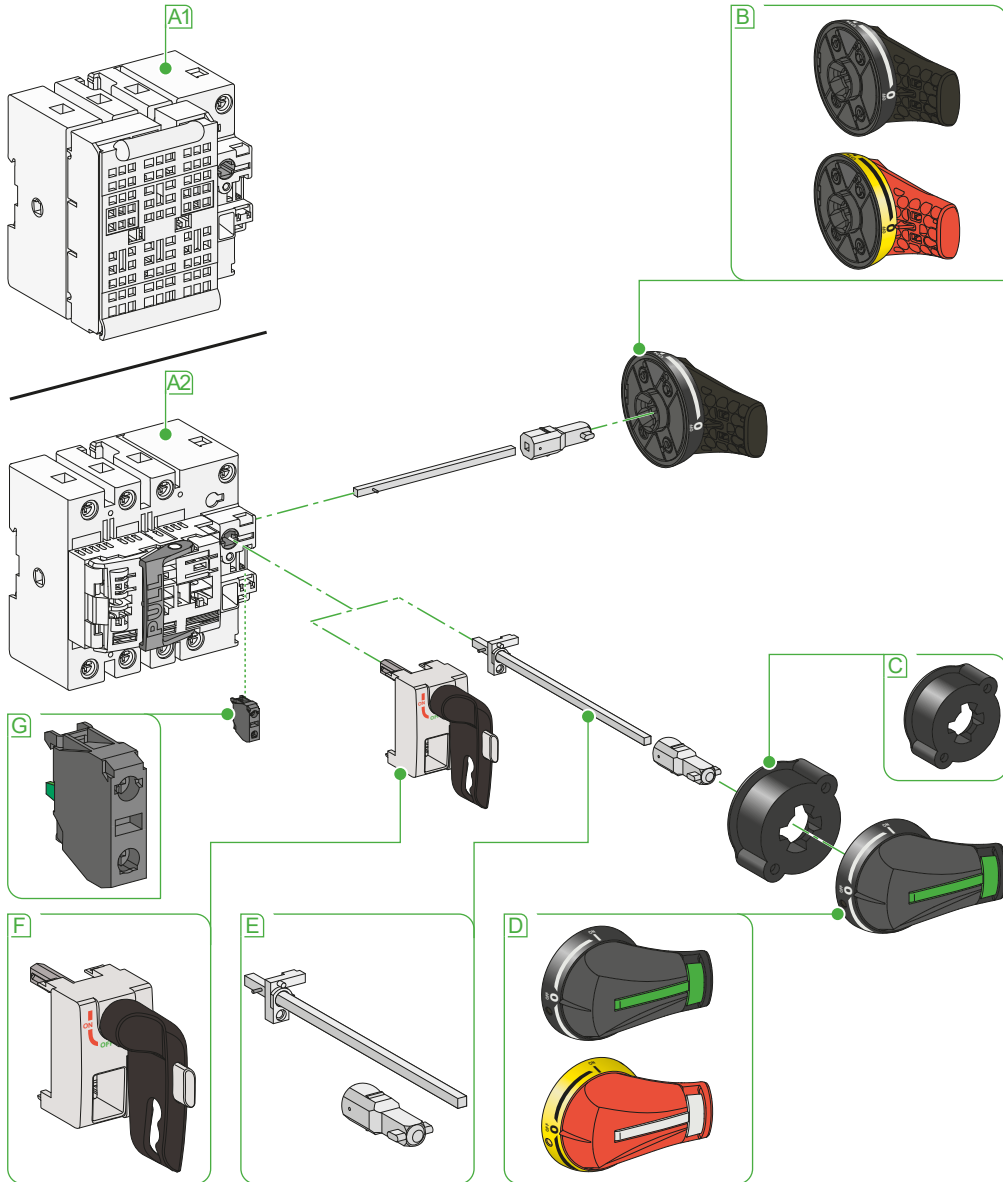

- A** Switch disconnecter fuse 3P or 4P (neutral switched, not protected)
1- GSB 32 A
2- GSC 32 A

- B** Extended lateral handles

- C** Guide cone

- D** Extended front handles

- E** Shaft

- F** Direct handle

- G** NO or NC auxiliary contacts

Presentation

Offer panorama

FuPacT GS 50/63 A

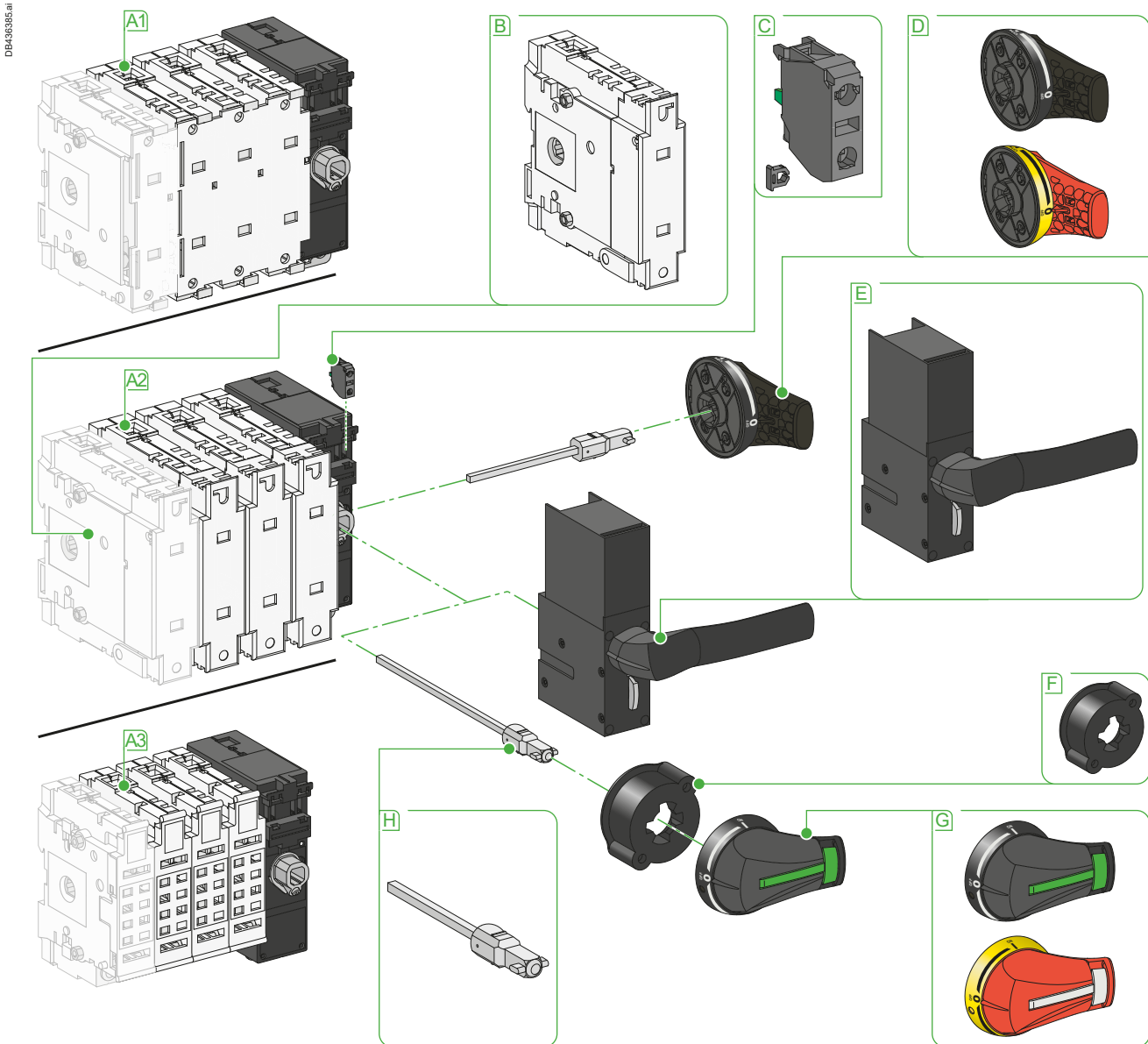

- A** Switch disconnector fuse 3P or 4P
 - 1- GSB 63 A
 - 2- GSC 50 A
 - 3- GSD 63 A
- B** External neutral module

- C** NO or NC auxiliary contacts
- D** Extended lateral handles
- E** Direct handle
- F** Guide cone

- G** Extended front handles
- H** Shaft

Offer panorama

FuPacT GS 100-160 A

DB46386.ai

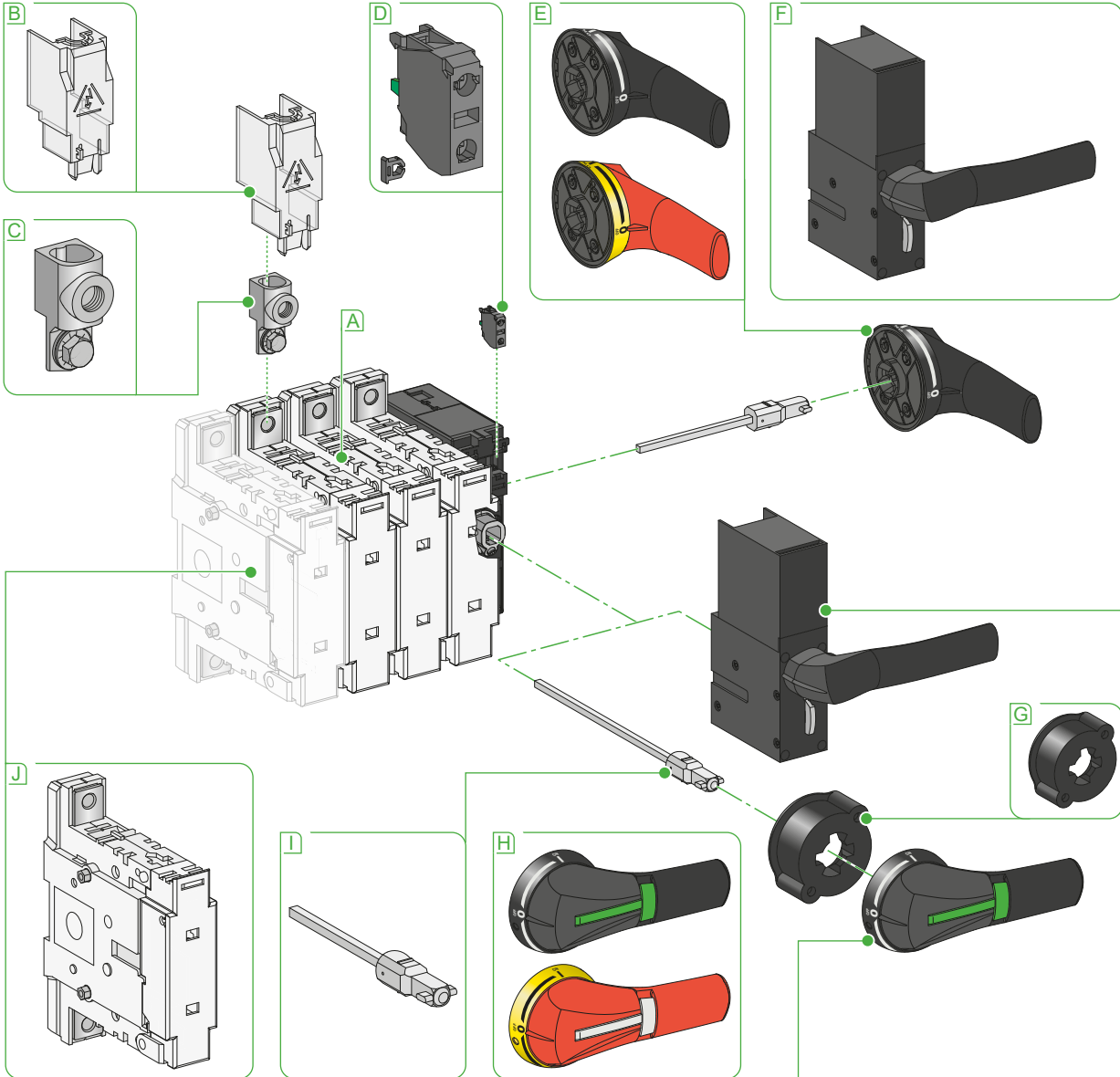

- A** Switch disconnecter fuse 3P or 4P
 - GSB 100/160 A
 - GSC 125 A
 - GSD 125/160 A

- B** Terminal shield

- C** Bare cable connector
- D** NO or NC auxiliary contacts
- E** Extended lateral handles

- G** Guide cone
- H** Extended front handles
- I** Shaft
- J** External neutral module

Presentation
 Offer panorama
 FuPacT GS 200/400 A

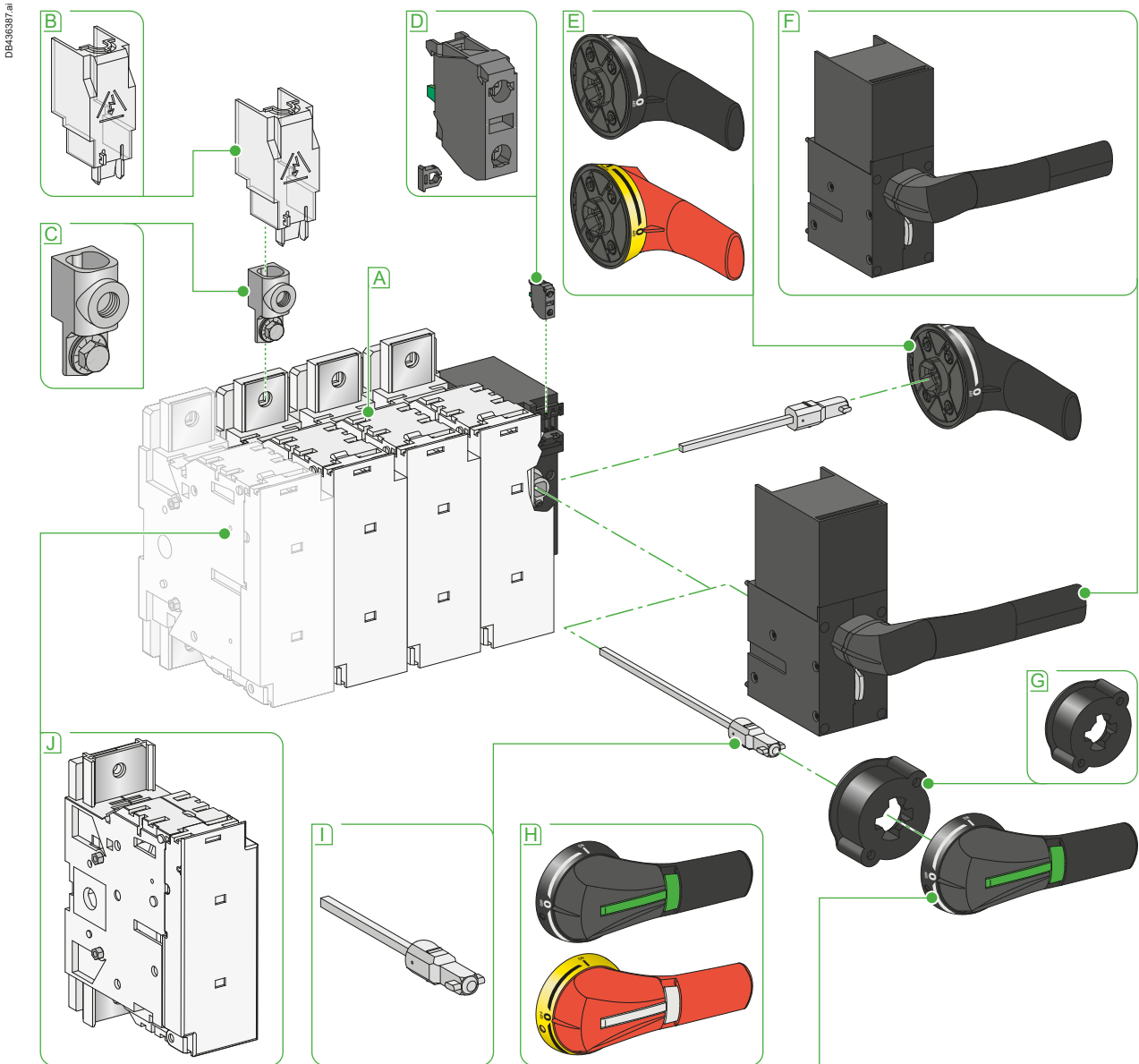

- A** Switch disconnecter fuse 3P or 4P
 - GSB 200/250/400 A
 - GSD 250/400 A
- B** Terminal shield
- C** Bare cable connector

- D** NO or NC auxiliary contacts
- E** Extended lateral handles
- F** Direct handle
- G** Guide cone

- H** Extended front handles
- I** Shaft
- J** External neutral module

Offer panorama

FuPacT GS 630/800 A

DB496388.ai

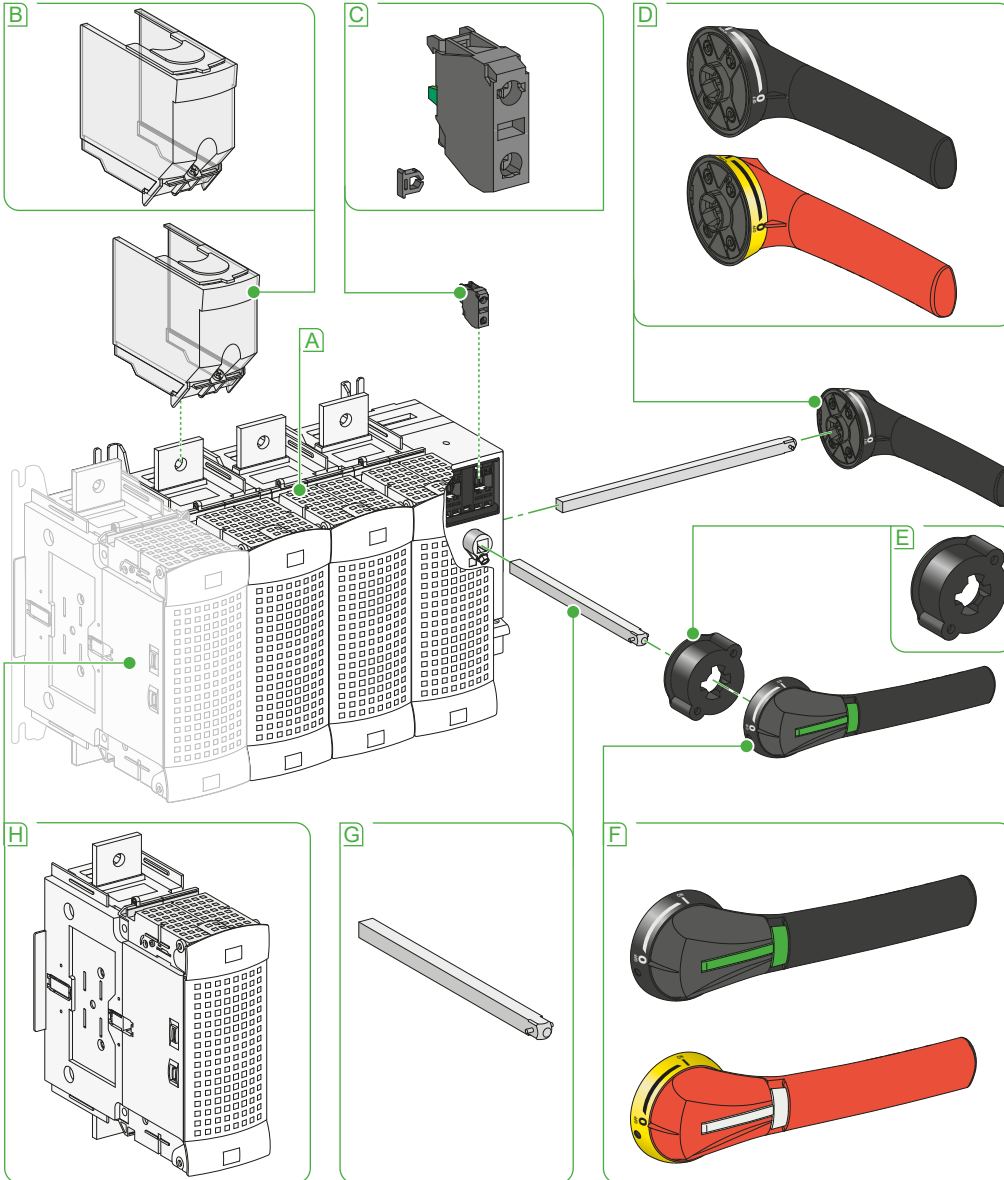

A Switch disconnecter fuse 3P or 4P
 ■ GSB 630/800 A
 ■ GSD 630/800 A

B Terminal shield

C NO or NC auxiliary contacts

D Extended lateral handles

E Guide cone

F Extended front handles

G Shaft

H External neutral module

DB436385.ai

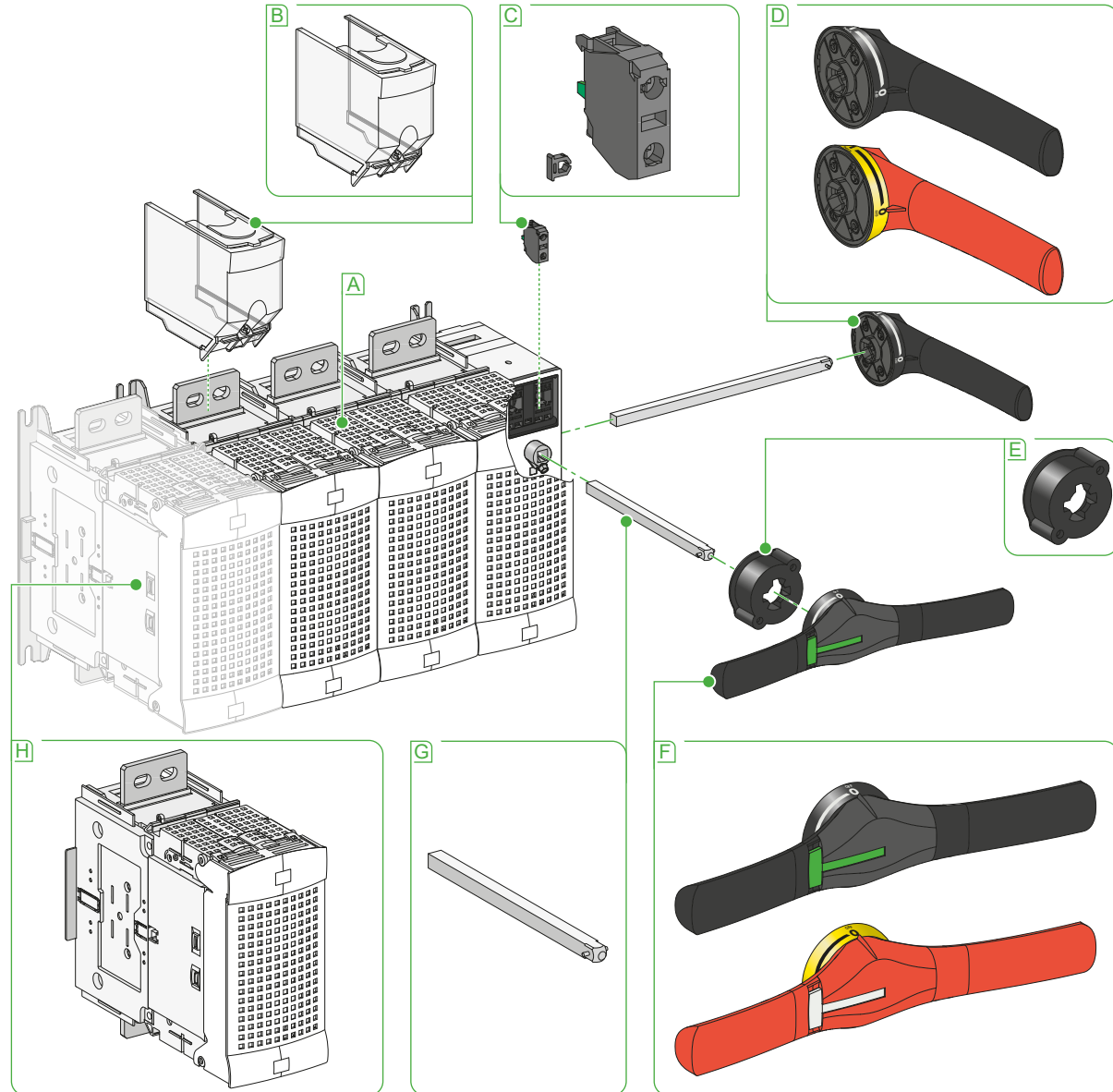

- A** Switch disconnecter fuse 3P or 4P
 - GSB 1250 A
 - GSD 1250 A
- B** Terminal shield

- C** NO or NC auxiliary contacts
- D** Extended lateral handles
- E** Guide cone

- F** Extended front handles
- G** Shaft
- H** External neutral module

IEC switch-disconnector-fuses for use with NFC or DIN fuses

From 32 to 1250 A

Switch-disconnector-fuse characteristics

Type		GSC32	GSC50	GSD63		
Environment						
Conforming to standards	Switch-disconnector-fuses	IEC 60947-3				
	Fuses	IEC60269/NFC63320 & IEC60269/BS88				
Product certifications		IEC and CCC				
Degree of protection conforming to IEC 60529	On Front panel, with terminal covers	IP 20				
Ambient air temperature around the device	Storage	°C	-50 ...+85			
	Operation	°C	-20...+70			
Flame resistance conforming to IEC 60695-2-1	Body	°C	960			
	Fuse cover	°C	-	850		
Pole characteristics following IEC 60947-1 / IEC 60947-3 et EN 60947-1 / EN 60947-3						
Number of poles / Number of fuses	3 poles / 3 fuses		■	■		
	3 poles / Neutral switched NOT Protected		■	-		
	4 poles / 4 fuses		-	■		
Type of fuses	Fuse size		10x38	14x51		
Conventional thermal current	At ambient temperature (Ith) at 35°C	A	32	50	63	
	Maximum admissible power dissipated by the fuse	W	2.9	4.6	6.0	
	Maximum power dissipated by a pole	W	1.2	4.6	4.4	
Derating	in the open air or in cubicle	at 40°C	A	30	48	60
		at 50°C	A	27	43	54
		at 60°C	A	24	37	47
		at 70°C	A	20	31	39
Rated insulation voltage (Ui)	50/60 Hz	V	800	800	800	
Rated impulse withstand voltage (Uimp)		kV	8	8	8	
Rated operating voltage - AC (Ue)	50/60 Hz	V	690	690	690	
Rated operating voltage - AC 20 (Ue)		V	800	800	800	
Rated operational current at 50/60 Hz	Cat. AC-22A/B ^[1]	220/240 V	A	32	50	-
		380/415 V	A	32	50	-
		660/690 V	A	32	50	-
Rated operational current at 50/60 Hz	Cat. AC-23A/B ^[1]	220/240 V	A	32	50	-
		380/415 V	A	32	50	-
		660/690 V	A	32	50	63 ^[2]
Rated operational power	Cat. AC-23A/B ^[1]	380/415 V	kW	15	25	30
		660/690 V	kW	25	45	55
Breaking capacity with fuses (Iq)	400 V	kA rms	-	-	-	
	415 V	kA rms	100	100	100	
	500 V	kA rms	-	-	-	
	690 V	kA rms	100	100	100	
Mechanical durability	in cycle 0/C		10000	10000	10000	
Durability in cycle 0/F	Category		Category A			
	Mechanical	in cycle 0/C		8500	8500	
	Electrical	AC22A 415 V		1500	1500	1500
		AC22A 690 V		1500	1500	1500
		AC23A 415 V		1500	1500	1500
AC23A 690 V			1500	1500	1500	
Sectioning ability			Yes	Yes	Yes	
Fully apparent cut			No	No	No	
Degree of pollution			III	III	III	

[1] Category "A": frequent operating cycles, category "B": infrequent operating cycles.

[2] Category "A".

[3] Category "B".

	GSC125	GSD125	GSD160	GSD250	GSD400	GSD630	GSD800	GSD1250
IEC 60947-3								
IEC60269/NFC63320 & IEC60269/BS88								
IEC and CCC								
IP 20								
-50 ...+85								
-20...+70								
960								
850								
■	■	■	■	■	■	■	■	■
-	-	-	-	-	-	-	-	-
■	■	■	■	■	■	■	■	■
22x58	NH 00	NH 00	NH 1	NH 2	NH 3	NH 3	NH 3	NH 4
125	125	160	250	400	630	800	1250	
10.4	12.0	12.0	23.0	33.0	60.0	65.0	110.0	
8.6	8.6	10.4	19	24.4	61	68	154	
119	119	152	238	382	600	762	1195	
107	107	136	213	345	537	682	1079	
93	93	119	186	305	469	595	955	
78	78	100	156	262	393	499	819	
800	800	800	800	800	1000	1000	1000	
8	8	8	8	8	12	12	12	
690	690	690	690	690	690	690	690	
800	800	800	800	800	1000	1000	1000	
125	-	-	-	-	-	-	-	
125	-	-	-	400 ^[3]	-	-	-	
125	-	160 ^[2]	-	400 ^[3]	630 ^[3]	800 ^[3]	-	
125	-	-	-	-	-	-	-	
125	-	-	-	400 ^[3]	-	-	1250 ^[3]	
100	125 ^[2]	-	250 ^[2]	400 ^[2]	-	-	-	
70	70	80	132	220	355	450	750	
110	110	110	220	295	295	600	900	
-	-	-	-	-	-	-	-	
80	80	80	80	50	100	100	100	
-	-	-	-	-	-	-	-	
100	50	50	50	50	100	100	100	
10000	10000	10000	10000	8000	5000	5000	5000	
Category A				Category B				
7000	7000	7000	7000	800	800	500	500	
1000	1000	1000	1000	200	200	100	100	
1000	1000	1000	1000	200	200	100	100	
1000	1000	1000	1000	-	-	-	100	
1000	1000	1000	1000	-	-	-	-	
Yes	Yes	Yes	Yes	Yes	Yes	Yes	Yes	
No	No	No	No	No	No	No	No	
III	III	III	III	III	III	III	III	



IEC switch-disconnector-fuses for use with NFC or DIN fuses

From 32 to 1250 A

Switch-disconnector-fuse characteristics

Type		GSC32	GSC50	GSD63	
Installation and connection					
Upstream / Downstream connection		■	■	■	
Rear connection		–	–	–	
Connexion material and surface treatment		White zinc plated steel	Tinned copper		
Control auxiliaries					
Direct front rotary handle		■	■	■	
Front extended handle		■	■	■	
Laterale extend handle		■	■	■	
Padlocking		■	■	■	
Signaling auxiliaries					
Auxiliary contact with pre-cut information		■	■	■	
Test position		■	■	■	
Installation and connection accessories					
Internal neutral link		–	■	■	
External neutral module		–	■	■	
Terminal covers		–	–	–	
Cable connector		–	–	–	
Dimensions and weights					
Overall dimensions W x H x D	3P	mm	96 x 98 x 65	121 x 118 x 87	136 x 162 x 116
	4P	mm	96 x 98 x 65	148 x 118 x 87	168 x 162 x 116
Approximate weight without fuses and accessories	3P	kg	0.5	0.8	1.0
	4P	kg	0.5	1.0	1.3
Operating torque (typical for a 3-pole)		Nm	8.7	8.7	8.7

GS1 AM110 and GS1 AM101 early break and signaling contact characteristics

Conventional thermal current (I _{th}) for ambient temperature ≤ 40 °C		A	10
Rated operational current (I _e)	Cat. AC-15	A	120 V: 6 - 240 V: 3 - 400 V: 1.8 - 480 V: 1.5
	Cat. DC-13	A	24 V: 2.8 - 48 V: 1.4 - 125 V: 0.55 - 250 V: 0.27 - 400 V: 0.15
Durability	Number of operating cycles		Mechanical: 5000000 Electrical: cat. AC-15: 1000000
Cabling	Cable (c.s.a. min/max)	mm ²	Min: 1 x 0.22 - max: 2 x 2.5

	GSC125	GSD125	GSD160	GSD250	GSD400	GSD630	GSD800	GSD1250
	■	■	■	■	■	■	■	■
	-	-	-	-	-	■	■	■
Tinned copper								
	■	■	■	■	■	-	-	-
	■	■	■	■	■	■	■	■
	■	■	■	■	■	■	■	■
	■	■	■	■	■	■	■	■
	■	■	■	■	■	■	■	■
	■	■	■	■	■	-	-	-
	■	■	■	■	■	■	■	■
	■	■	■	■	■	■	■	■
	■	■	■	■	■	■	■	■
	■	■	■	■	■	-	-	-
	148 x 162 x 116	148 x 162 x 116	148 x 162 x 116	234 x 195 x 146	252 x 205 x 149	364 x 300 x 250	364 x 300 x 250	442 x 300 x 289
	184 x 162 x 116	184 x 162 x 116	184 x 162 x 116	294 x 195 x 146	318 x 205 x 149	458 x 300 x 250	458 x 300 x 250	562 x 300 x 289
	1.5	1.5	1.8	3.2	4.8	16.0	17.0	25.0
	2.0	2.0	2.3	4.5	6.1	20.0	21.5	30.0
	8.7	8.7	9.7	13	17	56	56.7	62



IEC switch-disconnector-fuses for use with BS fuses

From 32 to 1250 A

Switch-disconnector-fuse characteristics

Type		GSB32	GSB63	GSB100		
Environment						
Conforming to standards	Switch-disconnector-fuses	IEC 60947-3				
	Fuses	IEC60269/NFC63320 & IEC60269/BS88				
Product certifications		IEC and CCC				
Degree of protection conforming to IEC 60529	On Front panel, with terminal covers	IP 20				
Ambient air temperature around the device	Storage	°C	-50 ...+85			
	Operation	°C	-20...+70			
Flame resistance conforming to IEC 60695-2-1	Body	°C	960			
	Fuse cover	°C	-	850		
Pole characteristics following IEC 60947-1 / IEC 60947-3 et EN 60947-1 / EN 60947-3						
Number of poles / Number of fuses	3 poles / 3 fuses		■	■	■	
	3 poles / Neutral switched NOT Protected		■	-	-	
	4 poles / 4 fuses		-	■	■	
Type of fuses	Fuse size		A1	A2-A3	A4	
Conventional thermal current	At ambient temperature (Ith) at 35°C	A	32	63	100	
	Maximum admissible power dissipated by the fuse	W	2.9	3.8	8.4	
	Maximum power dissipated by a pole	W	1.2	4.4	3.7	
Derating	in the open air or in cubicle	at 40°C	A	30	60	95
		at 50°C	A	27	54	85
		at 60°C	A	24	47	74
		at 70°C	A	20	39	62
Rated insulation voltage (Ui)	50/60 Hz	V	800	800	800	
Rated impulse withstand voltage (Uimp)		kV	8	8	8	
Rated operating voltage - AC (Ue)	50/60 Hz	V	690	690	690	
Rated operating voltage - AC 20 (Ue)		V	800	800	800	
Rated operational current at 50/60 Hz	Cat. AC-22A/B ^[1]	220/240 V	A	-	-	-
		380/415 V	A	-	-	-
		660/690 V	A	-	-	-
Rated operational current at 50/60 Hz	Cat. AC-23A/B ^[1]	220/240 V	A	-	-	-
		380/415 V	A	-	-	-
		660/690 V	A	32 ^[2]	63 ^[2]	100 ^[2]
Rated operational power	Cat. AC-23A/B ^[1]	380/415 V	kW	15	30	51
		660/690 V	kW	-	55	90
Breaking capacity with fuses (Iq)		400 V	kA rms	-	-	-
		415 V	kA rms	100	100	80
		500 V	kA rms	-	-	-
		690 V	kA rms	80	100	50
Mechanical durability	in cycle 0/C		10000	10000	10000	
Durability in cycle 0/F	Category		Category A			
	Mechanical	in cycle 0/C		8500	8500	8500
	Electrical	AC22A 415 V		1500	1500	1500
		AC22A 690 V		1500	1500	1500
		AC23A 415 V		1500	1500	1500
		AC23A 690 V		1500	1500	1500
AC23B 415 V		-	-	-		
Sectioning ability			Yes	Yes	Yes	
Fully apparent cut			No	No	No	
Degree of pollution			III	III	III	

[1] Category "A": frequent operating cycles, category "B": infrequent operating cycles.

[2] Category "A".

[3] Category "B".

	GSB160	GSB200	GSB250	GSB400	GSB630	GSB800	GSB1250
	IEC 60947-3						
	IEC60269/NFC63320 & IEC60269/BS88						
	IEC and CCC						
	IP 20						
	-50 ...+85						
	-20...+70						
	960						
	850						
	■	■	■	■	■	■	■
	-	-	-	-	-	-	-
	■	■	■	■	■	■	■
	A4	B1-B2	B1...B3	B1...B4	C2	C3	D1
	160	200	250	400	630	800	1250
	15.3	14.3	19.7	29.6	55	70	100
	10.4	15.6	13.8	24.4	61	68	154
	152	190	238	382	600	762	1195
	136	170	213	345	537	682	1079
	119	149	186	305	469	595	955
	100	125	156	262	393	499	819
	800	800	800	800	1000	1000	1000
	8	8	8	8	12	12	12
	690	690	690	690	690	690	690
	800	800	800	800	1000	1000	1000
	-	-	-	-	-	-	-
	-	-	-	-	-	-	-
	160 ^[3]	200 ^[2]	-	400 ^[3]	630 ^[3]	800 ^[3]	1250 ^[3]
	-	-	-	-	-	-	-
	160 ^[3]	-	-	-	-	-	-
	160 ^[2]	160 ^[2]	250 ^[2]	-	-	-	-
	80	100	132	220	355	450	750
	110	150	220	295	295	400	900
	-	-	-	-	-	-	-
	80	80	80	50	100	100	100
	-	-	-	-	-	-	-
	50	50	50	50	100	100	100
	10000	10000	10000	8000	5000	5000	5000
	Category A			Category B			
	7000	7000	7000	800	800	500	500
	1000	1000	1000	200	200	100	100
	1000	1000	1000	200	200	100	100
	1000	1000	1000	-	-	-	100
	1000	1000	1000	-	-	-	-
	-	-	-	-	-	-	-
	Yes	Yes	Yes	Yes	Yes	Yes	Yes
	No	No	No	No	No	No	No
	III	III	III	III	III	III	III



IEC switch-disconnector-fuses for use with BS fuses

From 32 to 1250 A

Switch-disconnector-fuse characteristics

Type		GSB32	GSB63	GSB100	
Installation and connection					
Upstream / Downstream connection		■	■	■	
Rear connection		–	–	–	
Connexion material and surface treatment		White zinc plated steel	Tinned copper		
Control auxiliaries					
Direct front rotary handle		■	■	■	
Front extended handle		■	■	■	
Laterale extend handle		■	■	■	
Padlocking		■	■	■	
Signaling auxiliaries					
Auxiliary contact with pre-cut information		■	■	■	
Test position		■	■	■	
Installation and connection accessories					
Internal neutral link		–	–	–	
External neutral module		–	■	■	
Terminal covers		–	–	■	
Cable connector		–	–	■	
Dimensions and weights					
Overall dimensions W x H x D	3P	mm	96 x 98 x 83	136 x 162 x 116	148 x 162 x 116
	4P	mm	96 x 98 x 83	168 x 162 x 116	184 x 162 x 116
Approximate weight without fuses and accessories	3P	kg	0.5	1.0	1.5
	4P	kg	0.5	1.3	2.0
Operating torque (typical for a 3-pole)		Nm	8.7	8.7	9.7

GS1 AM110 and GS1 AM101 early break and signaling contact characteristics

Conventional thermal current (I _{th}) for ambient temperature ≤ 40 °C	A	10
Rated operational current (I _e)	Cat. AC-15	A 120 V: 6 - 240 V: 3 - 400 V: 1.8 - 480 V: 1.5
	Cat. DC-13	A 24 V: 2.8 - 48 V: 1.4 - 125 V: 0.55 - 250 V: 0.27 - 400 V: 0.15
Durability	Number of operating cycles	Mechanical: 5000000 Electrical: cat. AC-15: 1000000
Cabling	Cable (c.s.a. min/max)	mm² Min: 1 x 0.22 - max: 2 x 2.5

	GSB160	GSB200	GSB250	GSB400	GSB630	GSB800	GSB1250
	■	■	■	■	■	■	■
	-	-	-	-	■	■	■
Tinned copper							
	■	■	■	■	-	-	-
	■	■	■	■	■	■	■
	■	■	■	■	■	■	■
	■	■	■	■	■	■	■
	■	■	■	■	■	■	■
	■	■	■	■	-	-	-
	-	-	-	-	-	-	-
	■	■	■	■	■	■	■
	■	■	■	■	■	■	■
	■	■	■	■	-	-	-
	190 x 162 x 136	234 x 195 x 146	234 x 195 x 146	252 x 205 x 149	364 x 300 x 250	364 x 300 x 250	442 x 300 x 289
	240 x 162 x 136	294 x 195 x 146	294 x 195 x 146	318 x 205 x 149	458 x 300 x 250	458 x 300 x 250	562 x 300 x 289
	2.3	3.2	3.2	4.8	16.0	17.0	25.0
	2.3	4.5	4.5	6.1	20.0	21.5	30.0
	9.7	13	13	17	56	56.7	62



Presentation of the FuPacT GS range

FuPacT GSB and GSC 32

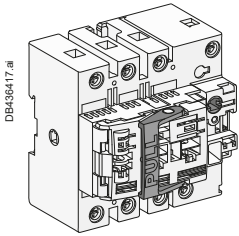

FuPacT GSC32

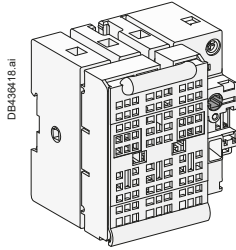

FuPacT GSB32

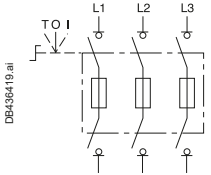

3 poles, 3 fuse-links

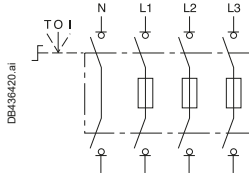

4 poles, 3 fuse-links

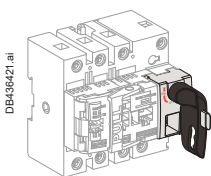

Direct handle

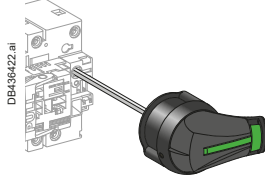

Extended front handles

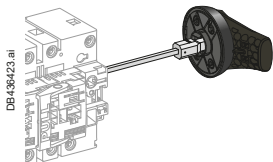

Extended lateral handles

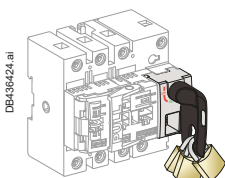

3 padlocks on direct handle

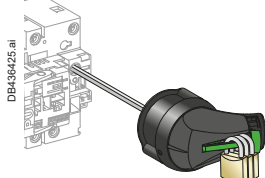

3 padlocks on extended handle

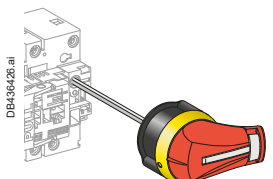

Extended front handles, red handle on yellow front

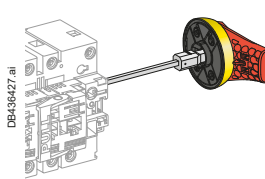

Extended lateral handles, red handle on yellow front

Functions

The FuPacT GSB32 and GSC32 switch disconnecter fuses are used with fuses that protect electrical circuits against overloading and short circuits.

They provide a circuit cut-off function by means of a double break upstream and downstream of the fuses.

They also provide a switch function allowing circuits to be cut-off when under load.

Format and installation

The FuPacT GSC32 and GSB32 devices are compact and monobloc (96 mm wide), thereby optimizing the space used.

The dimensions of the 3- and 4-pole devices are identical.

The devices are installed either on a DIN rail or by means of mounting screws on a plate. The mounting points are incorporated into the products. There is no need to add accessories to fasten the products to a plate.

Number of poles

The devices are available as 3- or 4-pole versions cut-off by the open/close control. The 3P devices are fitted with 3 fuse holders, cut-off upstream and downstream of the fuse.

The 4P devices are fitted with 3 fuse holders, cut-off upstream and downstream of the fuse and a neutral connection, cut-off, UNPROTECTED.

Controlling the devices

■ The devices can be controlled in three ways:

- By direct control using reference GS1AH103. This control is fitted directly to the device.
- By extended frontal control with a handle installed on the door of the electrical cabinet.
- By extended lateral control with a handle installed on the side of the electrical cabinet.

■ The control rods are available in 3 lengths: 200 , 320 or 400 m.

Note: They must be ordered separately.

■ Several types of IP65 control handle are available and must be ordered separately

- For frontal installation, black or yellow/red with or without test position
- For lateral installation, black or yellow/red without test position

■ The front handles allow the door to be interlocked with the control rod of the device. This prevents the opening of the door cabinet if the device is in the ON position.

■ The lateral controls do not allow the door and the control rod to be interlocked. They must not be used as a frontal control.

Lockout system

The function whereby the devices can be locked in the OFF position is available on the direct control handle and the extended control handles.

It allows up to 3 padlocks to be fitted on each handle.

Using the devices as emergency switch disconnecter fuse

The FuPacT switch disconnecter fuse can be used as emergency cut-off devices.

For this application, they must be easily visible, accessible and identifiable (see standards and rules: VDE 0660, VDE 0113, CNOMO, etc.).

For the purposes of easy identification, the emergency cut-off switch disconnectors fuse use special colors, as stipulated by the standards and different from those of the standard version:

- Yellow for the front face of the device or the control plate
- Red for the handle.

The performance characteristics of the FuPacT emergency cut-off switch disconnecter fuse are the same as those of the standard version.

Presentation of the FuPacT GS range

FuPacT GSB and GSC 32

Connecting the devices

The FuPacT GSC32 and GSB32 devices are fitted with screw terminals which can accommodate conductors of 2.5 to 16 mm² cross section.

Fuse type and installation

- GSC 32 supports NF 10*38 cylindrical fuses compliant with IEC60269/NFC63320 standards.
- GSB 32 supports BS A1 fuses compliant with IEC60269/BS88 standards.

Note: The fuses are not supplied with the devices.

- For GSC 32, the fuses are installed in the cover, opened prior to installation.
- For GSB 32, the fuses are installed in the device on the mountings provided for this purpose. Manual tightening is strongly advised in order to comply with the recommended tightening torques (consult the instruction sheet).

Cone guide

This accessory allows the control rod to be re-centred with regard to the hole drilled in the door. It is fitted to the door and serves to offset a drilling discrepancy or a bowing of the long rods of ±10 mm

Auxiliary contacts/Pre cut-off

The GSC32 and GSB32 devices can be fitted with 4 auxiliary contacts enabling the mechanical position of the device to be indicated. 2 auxiliary contacts are fitted directly to the device (see manual) and 2 others can be stacked on top of the first ones.

The NO or NC auxiliary contacts thus allow the ON, OFF and TEST positions of the device to be indicated.

The TEST position is indicated if a handle WITH TEST position is used.

The auxiliary contacts also serve to indicate the pre cut-off of the device, as soon as the handle is activated but before the poles are opened.

This allows a charge to be stopped before cutting the main power supply.

- References GS1AM110 and GS1AM101 have 1 auxiliary contact (NO or NC) + 2 plastic tappets.
- References ZBE101 and ZBE102 are the auxiliary contacts alone.

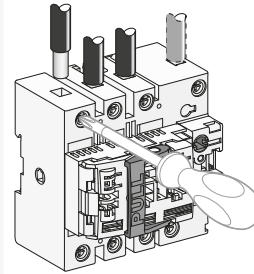

DB436428.ai

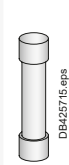

NFC fuse

DB425715.eps



BS fuse

DB436429.ai

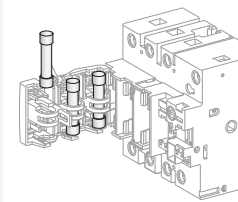

DB436527.ai

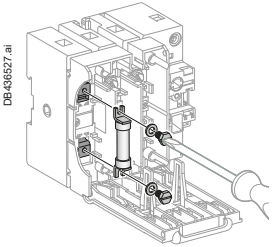

DB436528.ai



DB436430.ai

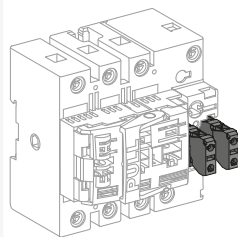

DB436431.ai

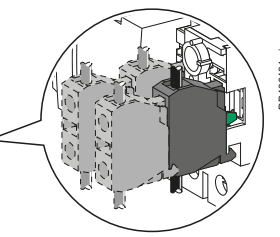

DB436431.ai



Detailed presentation

Presentation of the FuPacT GS range

FuPacT GSC 50, GSB and GSD 63

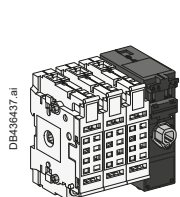

FuPacT GSC 50

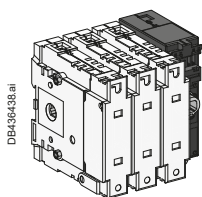

FuPacT GSD 63

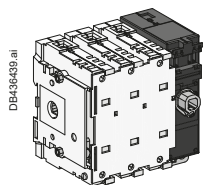

FuPacT GSB 63

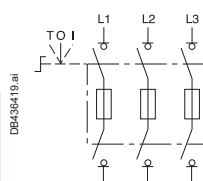

3 poles, 3 fuse-links

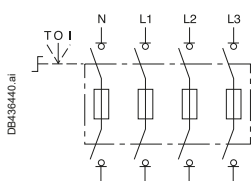

4 poles, 4 fuse-links

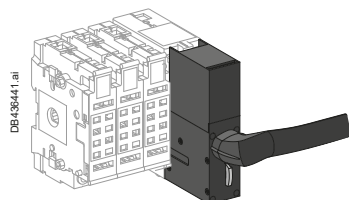

Direct handle

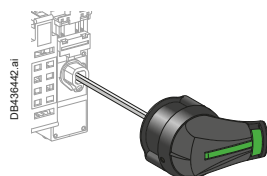

Extended front handles

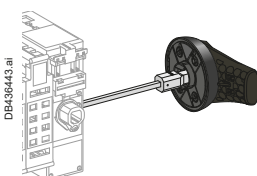

Extended lateral handles

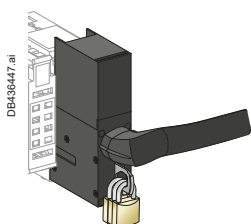
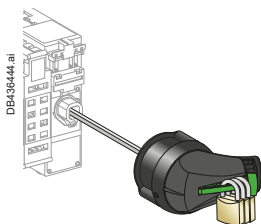
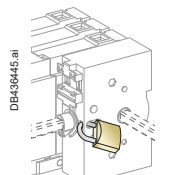
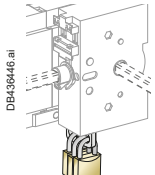
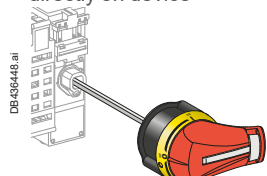
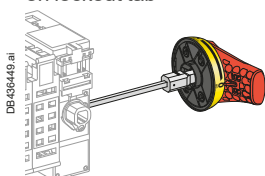
3 padlocks
on direct handle3 padlocks
on extended handlesingle padlock
directly on device3 padlocks
on lockout tabExtended front handles,
red handle on yellow frontExtended lateral handles,
red handle on yellow front

Functions

The FuPacT GSC50, GSB63 and GSD63 switch disconnecter fuses are used with fuses that protect electrical circuits against overloading and short circuits.

They provide a circuit cut-off function by means of a double break upstream and downstream of the fuses.

They also provide a switch function allowing circuits to be cut-off when under load.

Format and installation

The FuPacT GSC 50, GSD 63 and GSB 63 devices are compact, optimizing the space used. They consist of poles assembled and tested in factory as well as a housing for the control mechanism.

The transparent covers make it possible to see the presence or absence of fuses and their rating.

The devices are installed either on a DIN rail or by means of mounting screws on a plate. The mounting points are incorporated into the products. There is no need to add accessories to fasten the products to a plate.

Number of poles

The devices are available as 3- or 4-pole versions cut-off by the open/close control. The 3P devices are fitted with 3 fuse holders, cut-off upstream and downstream of the fuse.

The 4P devices are fitted with 4 fuse holders, cut-off upstream and downstream of the fuse. One of the poles may be fitted with a neutral link (see internal neutral links).

Controlling the devices

- The devices can be controlled in three ways:
 - By direct control using reference LV481701. This control is fitted directly to the housing of the device control mechanism.
 - By extended frontal control with a handle installed on the door of the electrical cabinet.
 - By extended lateral control with a handle installed on the side of the electrical cabinet.

- The control rods are available in 3 lengths: 200, 320 or 400 mm.

Note: They must be ordered separately.

- Several types of IP65 control handle are available and must be ordered separately.
 - In the event of frontal installation, black or yellow/red, with or without test position.
 - For lateral installation, black or yellow/red, without test position.

- The front handles allow the door to be interlocked with the control rod of the device. This prevents the opening of the door cabinet if the device is in the ON position.

- The lateral controls do not allow the door and the control rod to be interlocked. They must not be used as a frontal control.

Lockout system

The function whereby the devices can be locked in the OFF position is available on the direct control handle and the extended control handles.

It allows up to 3 padlocks to be fitted on each handle.

It is also possible to padlock the devices directly, either on the control unit using a single padlock or a multi-padlock lockout accessory or on the lockout tab located on the lower face of the control unit. This can accommodate up to 3 padlocks.

Using the devices as emergency switch disconnecter fuse

The FuPacT switch disconnecter fuse can be used as emergency cut-off devices.

For this application, they must be easily visible, accessible and identifiable (see standards and rules: VDE 0660, VDE 0113, CNOMO, etc.).

For the purposes of easy identification, the emergency cut-off switch disconnecter fuse use special colors, as stipulated by the standards and different from those of the standard version:

- Yellow for the front face of the device or the control plate
- Red for the handle.

The performance characteristics of the FuPacT emergency cut-off switch disconnecter fuse are the same as those of the standard version.

Presentation of the FuPacT GS range

FuPacT GSC 50, GSB and GSD 63

Connecting the devices

The FuPacT GSC 50, GSD 63 and GSB 63 devices are fitted with screw terminals which can accommodate conductors of:

- 10 to 25 mm² for the GSC 50
- 16 to 25 mm² for the GSD 63 and GSB 63.

Fuse type and installation

- GSC 50 supports NF 14*51 cylindrical fuses compliant with IEC60269/NFC63320 standards
- GSD 63 supports DIN 000 fuses compliant with IEC60269/NFC63320 standards
- GSB 63 supports BS A2 and A3 fuses compliant with IEC60269/BS88 standards

Note: The fuses are not supplied with the devices.

- For GSC 50 and GSD 63, the fuses are installed by rotating the transparent protective cover, with the power supply switched off, then inserting the fuses in the fuse holders.
- For GSB 63, the fuses are installed by removing the transparent protective cover, with the power supply switched off, then installing the fuses on the mounting provided for this purpose. Manual tightening is strongly advised in order to comply with the recommended tightening torques (consult the device manual).

External neutral module and internal neutral link

The NFC 50A and DIN 63A (LV481911 and LV481913) neutral links create a neutral connection in the device. The links are fitted instead of a fuse.

The external neutral modules are poles fitted with a removable neutral connection which is NOT CUT (no mechanism).

They are installed directly on the left-hand side of the product on the 3-pole device.

Cone guide

This accessory allows the control rod to be re-centred with regard to the hole drilled in the door. It is fitted to the door and serves to offset a drilling discrepancy or a bowing of the long rods of ±10 mm.

Auxiliary contacts / Pre cut-off

The FuPacT GSC 50, GSB 63 and GSD 63 devices can be fitted with 4 auxiliary contacts enabling the mechanical position of the device to be indicated. 2 auxiliary contacts are fitted directly to the device (see manual) and 2 others can be stacked on top of the first ones.

The NO or NC auxiliary contacts thus allow the ON, OFF and TEST positions of the device to be indicated

The TEST position is indicated if a handle WITH TEST position is used

The auxiliary contacts also serve to indicate the pre cut-off of the device, as soon as the handle is activated but before the poles are opened.

This allows a charge to be stopped before cutting the main power supply.

- References GS1AM110 and GS1AM101 have 1 auxiliary contact (NO or NC) + 2 plastic tappets.
- References ZBE101 and ZBE102 are the auxiliary contacts alone.

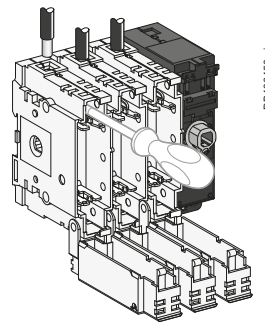

DB436450.ai

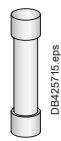

NFC fuse

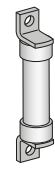

BS fuse



DIN fuse

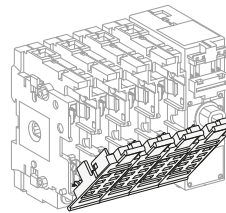

DB436452.ai

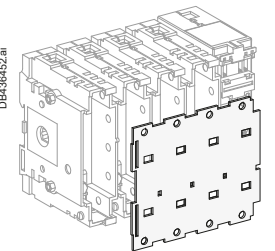

DB436453.ai

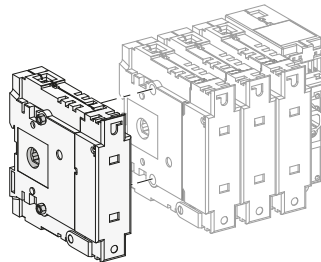

DB436454.ai

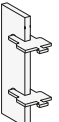

DIN link



DB436450.ai

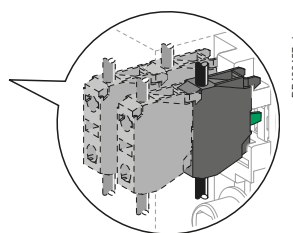
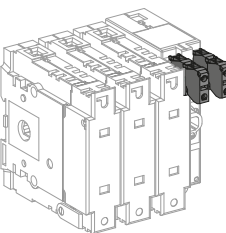

DB436457.ai

Presentation of the FuPacT GS range

FuPacT GSB 100, GSC and GSD 125, GSB and GSD 160

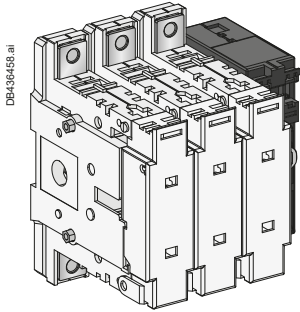

FuPacT GSB 100

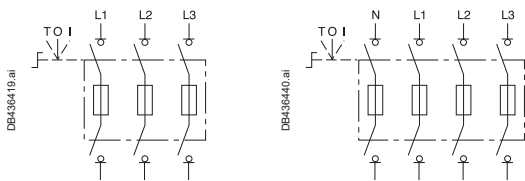

3 poles, 3 fuse-links

4 poles, 4 fuse-links

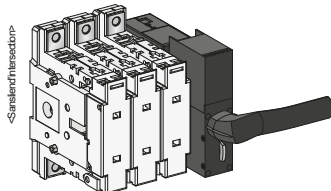

Direct handle

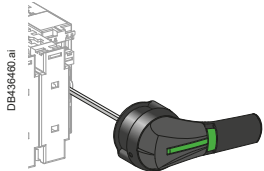

Extended front handles

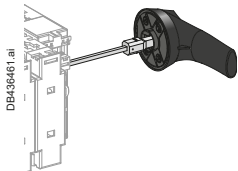

Extended lateral handles

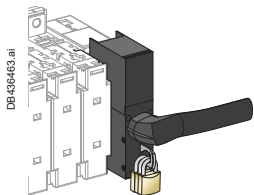

3 padlocks on direct handle

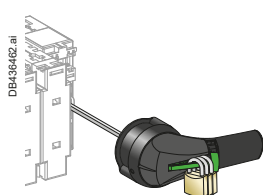

3 padlocks on extended handle

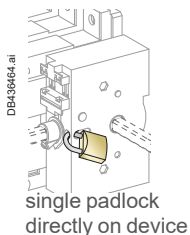

single padlock directly on device

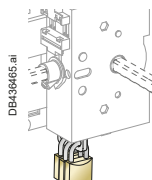

3 padlocks on lockout tab

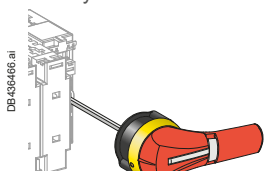

Extended front handles, red handle on yellow front

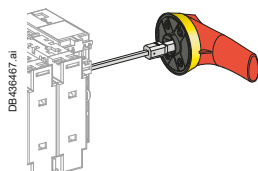

Extended lateral handles, red handle on yellow front

Functions

The FuPacT GSB 100, GSC and GSD 125, GSD and GSB 160 switch disconnecter fuses are used with fuses that protect electrical circuits against overloading and short circuits.

They provide a circuit cut-off function by means of a double break upstream and downstream of the fuses.

They also provide a switch function allowing circuits to be cut-off when under load.

Format and installation

The FuPacT GSB 100, GSC and GSD 125, GSD and GSB 160 devices are compact, optimizing the space used.

They consist of poles assembled and tested in factory as well as a housing for the control mechanism.

The transparent covers make it possible to see the presence or absence of fuses and their rating.

The devices are installed on a plate. The mounting points are incorporated into the products. There is no need to add accessories to fasten the products to a plate.

Number of poles

The devices are available as 3- or 4-pole versions cut-off by the open/close control. The 3P devices are fitted with 3 fuse holders, cut-off upstream and downstream of the fuse.

The 4P devices are fitted with 4 fuse holders, cut-off upstream and downstream of the fuse. One of the poles may be fitted with a neutral links.

Controlling the devices

■ The devices can be controlled in three ways:

- By direct control using reference LV481701. This control is fitted directly to the housing of the device control mechanism.
- By extended frontal control with a handle installed on the door of the electrical cabinet.
- By extended lateral control with a handle installed on the side of the electrical cabinet.

■ The control rods are available in 3 lengths: 200, 320 or 400 m.

Note: They must be ordered separately.

■ Several types of IP65 control handle are available and must be ordered separately.

- In the event of frontal installation, black or yellow/red, with or without test position.
- For lateral installation, black or yellow/red, without test position.

■ The front handles allow the door to be interlocked with the control rod of the device. This prevents the opening of the door cabinet if the device is in the ON position.

■ The lateral controls do not allow the door and the control rod to be interlocked. They must not be used as a frontal control.

Lockout system

The function whereby the devices can be locked in the OFF position is available on the direct control handle and the extended control handles.

It allows up to 3 padlocks to be fitted on each handle.

It is also possible to padlock the devices directly, either on the control unit using a single padlock or a multi-padlock lockout accessory or on the lockout tab located on the lower face of the control unit. This can accommodate up to 3 padlocks.

Using the devices as emergency switch disconnecter fuse

The FuPacT switch disconnecter fuse can be used as emergency cut-off devices.

For this application, they must be easily visible, accessible and identifiable (see standards and rules: VDE 0660, VDE 0113, CNOMO, etc.).

For the purposes of easy identification, the emergency cut-off switch disconnecter fuse use special colors, as stipulated by the standards and different from those of the standard version:

- Yellow for the front face of the device or the control plate
- Red for the handle.

The performance characteristics of the FuPacT emergency cut-off switch disconnecter fuse are the same as those of the standard version.

Presentation of the FuPacT GS range

FuPacT GSB 100, GSC and GSD 125, GSB and GSD 160

Connecting the devices

The FuPacT GSB 100, GSC and GSD 125, GSD and GSB 160 devices are fitted with tin-plated terminal to connect conductors fitted with cable lugs.

Connection accessories can be used to connect directly conductors without cable lugs. The accessories are fitted to the terminal and accommodate the bare conductors.

- FuPacT GSB 100, GSC and GSD 125, GSD and GSB 160: GS1AW33 (set of 3) or GS1AW34 (set of 4).

In order to protect the direct contact connections, terminal covers may be used.

- For FuPacT GSB 100, GSC and GSD 125: GS1AP33 (set of 3) or GS1AP34 (set of 4).
- For FuPacT GSD and GSB 160: GS1AP43 (set of 3) or GS1AP44 (set of 4).

Fuse type and installation

- GSB 100 support BS A4 fuses compliant with IEC60269/BS88 standards.
- GSC 125 support NF 22*58 cylindrical fuses compliant with IEC60269/NFC63320 standards.
- GSD 125 and GSD 160 support DIN 00 fuses compliant with IEC60269/NFC63320 standards.
- GSB 160 support BS A4 fuses compliant with IEC60269/BS88 standards.

Note: The fuses are not supplied with the devices.

- For all FuPacT GSC and GSD 125, GSD 160, the fuses are installed by rotating the transparent protective cover, with the power supply switched off, then inserting the fuses in the fuse holders.
- For the FuPacT GSB 100, GSB 160, the fuses are installed by rotating the transparent protective cover, with the power supply switched off, then installing the fuses in the housings provided for this purpose. Manual tightening is strongly advised in order to comply with the recommended tightening torques (consult the device manual).

External neutral module and internal neutral link

The NFC 125A and DIN 125A (LV481912 and LV481913) neutral links create a neutral connection in the device. The links are fitted instead of a fuse.

The external neutral modules are poles fitted with a removable neutral connection which is NOT CUT (no mechanism).

They are installed directly on the left-hand side of the product on the 3-pole device.

Cone guide

This accessory allows the control rod to be re-centred with regard to the hole drilled in the door. It is fitted to the door and serves to offset a drilling discrepancy or a bowing of the long rods of ± 10 mm.

Auxiliary contacts / Pre cut-off

The FuPacT GSB 100, GSC and GSD 125, GSD and GSB 160 devices can be fitted with 4 auxiliary contacts enabling the mechanical position of the device to be indicated.

2 auxiliary contacts are fitted directly to the device (see manual) and 2 others can be stacked on top of the first ones.

The NO or NC auxiliary contacts thus allow the ON, OFF and TEST positions of the device to be indicated

The TEST position is indicated if a handle WITH TEST position is used

The auxiliary contacts also serve to indicate the pre cut-off of the device, as soon as the handle is activated but before the poles are opened.

This allows a charge to be stopped before cutting the main power supply.

- References GS1AM110 and GS1AM101 have 1 auxiliary contact (NO or NC) + 2 plastic tappets.
- References ZBE101 and ZBE102 are the auxiliary contacts alone.

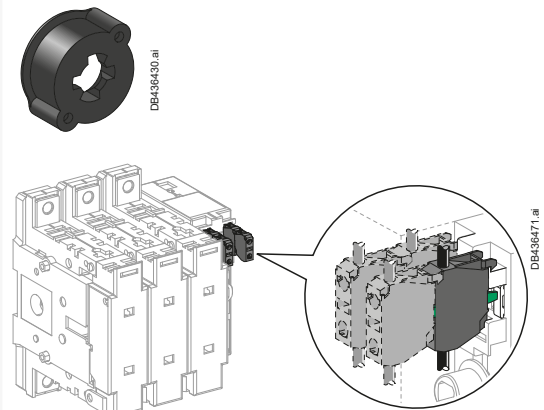
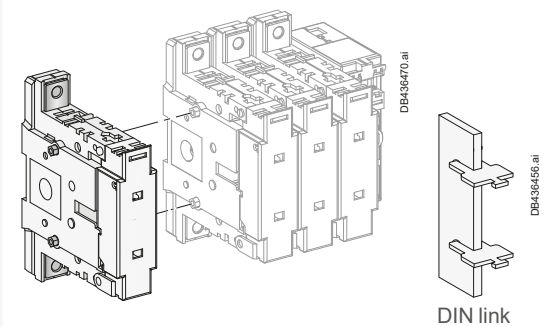
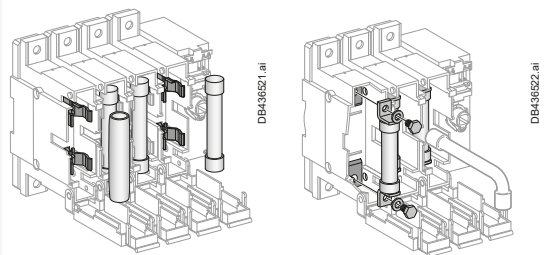
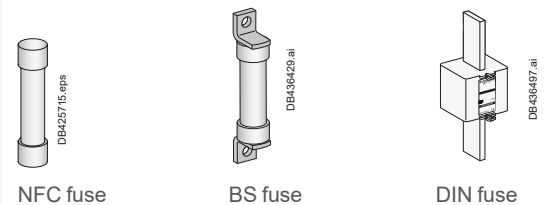
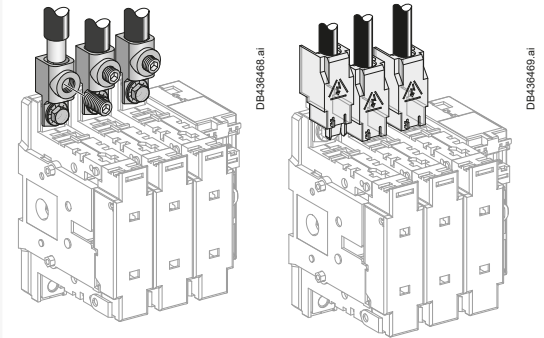

Presentation of the FuPacT GS range

FuPacT GSB 200, GSB and GSD 250, GSB and GSD 400

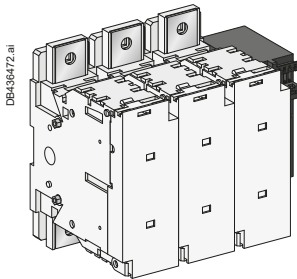

FuPacT GSB 250

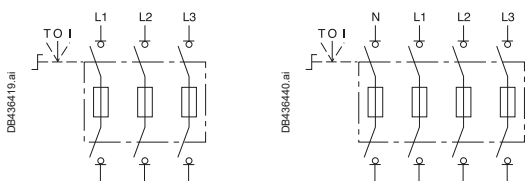

3 poles, 3 fuse-links

4 poles, 4 fuse-links

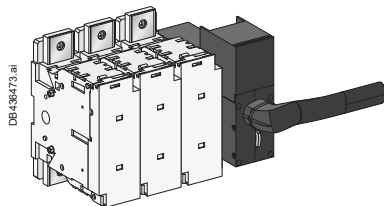

Direct handle

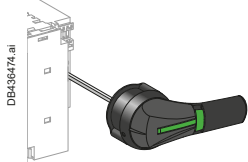

Extended front handles

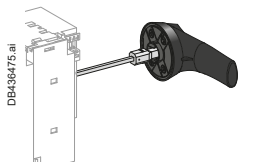

Extended lateral handles

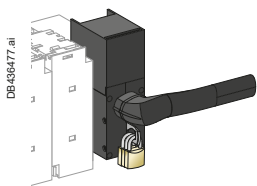

3 padlocks on direct handle

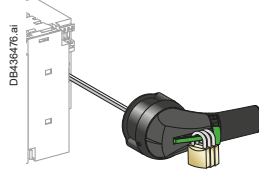

3 padlocks on extended handle

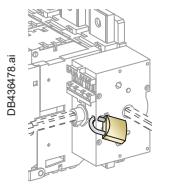

single padlock directly on device

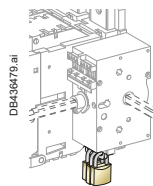

3 padlocks on lockout tab

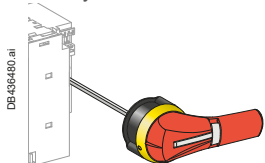

Extended front handles, red handle on yellow front

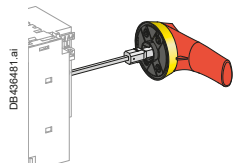

Extended lateral handles, red handle on yellow front

Functions

The FuPacT GSB 200, GSD and GSB 250, GSD and GSB 400 switch disconnecter fuses are used with fuses that protect electrical circuits against overloading and short circuits.

They provide a circuit cut-off function by means of a double break upstream and downstream of the fuses.

They also provide a switch function allowing circuits to be cut-off when under load.

Format and installation

The FuPacT GSB 200, GSD and GSB 250, GSD and GSB 400 devices are compact, optimizing the space used.

They consist of poles assembled and tested in factory as well as a housing for the control mechanism.

The transparent covers make it possible to see the presence or absence of fuses and their rating.

The devices are installed on a plate. The mounting points are incorporated into the products. There is no need to add accessories to fasten the products to a plate.

Number of poles

The devices are available as 3- or 4-pole versions cut-off by the open/close control. The 3P devices are fitted with 3 fuse holders, cut-off upstream and downstream of the fuse.

The 4P devices are fitted with 4 fuse holders, cut-off upstream and downstream of the fuse. One of the poles may be fitted with a neutral links.

Controlling the devices

- The devices can be controlled in three ways:
 - By direct control using reference LV481702. This control is fitted directly to the housing of the device control mechanism.
 - By extended frontal control with a handle installed on the door of the electrical cabinet.
 - By extended lateral control with a handle installed on the side of the electrical cabinet.

- The control rods are available in 3 lengths: 200, 320 or 400 mm. **Note:** They must be ordered separately.

- Several types of IP65 control handle are available and must be ordered separately.
 - In the event of frontal installation, black or yellow/red, with or without test position.
 - For lateral installation, black or yellow/red, without test position.
- The front handles allow the door to be interlocked with the control rod of the device. This prevents the opening of the door cabinet if the device is in the ON position.
- The lateral controls do not allow the door and the control rod to be interlocked. They must not be used as a frontal control.

Lockout system

The function whereby the devices can be locked in the OFF position is available on the direct control handle and the extended control handles.

It allows up to 3 padlocks to be fitted on each handle.

It is also possible to padlock the devices directly, either on the control unit using a single padlock or a multi-padlock lockout accessory or on the lockout tab located on the lower face of the control unit. This can accommodate up to 3 padlocks.

Using the devices as emergency switch disconnecter fuse

The FuPacT switch disconnecter fuse can be used as emergency cut-off devices.

For this application, they must be easily visible, accessible and identifiable (see standards and rules: VDE 0660, VDE 0113, CNOMO, etc.).

For the purposes of easy identification, the emergency cut-off switch disconnecters fuse use special colors, as stipulated by the standards and different from those of the standard version:

- Yellow for the front face of the device or the control plate
- Red for the handle.

The performance characteristics of the FuPacT emergency cut-off switch disconnecter fuse are the same as those of the standard version.

Presentation of the FuPacT GS range

FuPacT GSB 200, GSB and GSD 250, GSB and GSD 400

Connecting the devices

The FuPacT GSB200, GSD and GSB 250, GSD and GSB 400 devices are fitted with tin-plated terminal to connect conductors fitted with cable lugs.

Connection accessories can be used to connect directly conductors without cable lugs. The accessories are fitted to the terminal and accommodate the bare conductors.

- FuPacT GSB 200: GS1AW43 (set of 3) or GS1AW44 (set of 4).
- FuPacT GSD and GSB 250: GS1AW43 (set of 3) or GS1AW44 (set of 4).
- FuPacT GSD and GSB 400: LV481203 (set of 3) or LV481204 (set of 4).

In order to protect the direct contact connections, terminal covers may be used.

For FuPacT GSB 200, GSD and GSB 250, GSD and GSB 400:

- GS1AP43 (set of 3)
- GS1AP44 (set of 4)

Fuse type and installation

- GSB 200 supports BS B1 and B2 fuses compliant with IEC60269/BS88 standards.
- GSD 250 supports DIN 1 fuses compliant with IEC60269/NFC63320 standards.
- GSB 250 supports BS B1, B2 and B3 fuses compliant with IEC60269/BS88 standards.
- GSD 400 supports DIN 2 fuses compliant with IEC60269/NFC63320 standards.
- The GSB 400 support BS B1, B2, B3 and B4 fuses compliant with IEC60269/BS88 standards.

Note: The fuses are not supplied with the devices.

- For all FuPacT GSD 250 and GSD 400, the fuses are installed by rotating the transparent protective cover, with the power supply switched off, then inserting the fuses in the fuse holders.
- For the FuPacT GSB 200, GSB 250 and GSB 400, the fuses are installed by rotating the transparent protective cover, with the power supply switched off, then installing the fuses in the housings provided for this purpose. Manual tightening is strongly advised in order to comply with the recommended tightening torques (consult the device manual).

External neutral module and internal neutral link

The DIN 250 and DIN 400A (LV481915 and LV481916) neutral links create a neutral connection in the device. The links are fitted instead of a fuse.

The external neutral modules are poles fitted with a removable neutral connection which is NOT CUT (no mechanism).

They are installed directly on the left-hand side of the product on the 3-pole device.

Cone guide

This accessory allows the control rod to be re-centred with regard to the hole drilled in the door. It is fitted to the door and serves to offset a drilling discrepancy or a bowing of the long rods of ± 10 mm.

Auxiliary contacts / Pre cut-off

The FuPacT GSB 200, GSD and GSB 250, GSD and GSB 400 devices can be fitted with 8 auxiliary contacts enabling the mechanical position of the device to be indicated. 4 auxiliary contacts are fitted directly to the device (see manual) and 4 others can be stacked on top of the first ones.

Note: if using an LV481702 direct control fitted with its auxiliary contacts protective cover, the number of contacts that can be used is reduced to 4.

The NO or NC auxiliary contacts thus allow the ON, OFF and TEST positions of the device to be indicated.

The TEST position is indicated if a handle WITH TEST position is used

The auxiliary contacts also serve to indicate the pre cut-off of the device, as soon as the handle is activated but before the poles are opened.

This allows a charge to be stopped before cutting the main power supply.

- References GS1AM110 and GS1AM101 have 1 auxiliary contact (NO or NC) + 2 plastic tappets.
- References ZBE101 and ZBE102 are the auxiliary contacts alone.

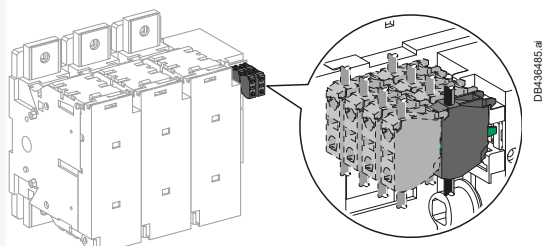
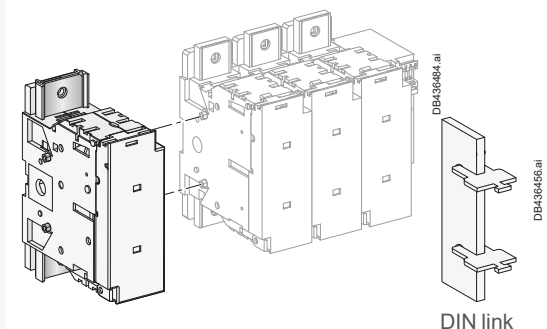
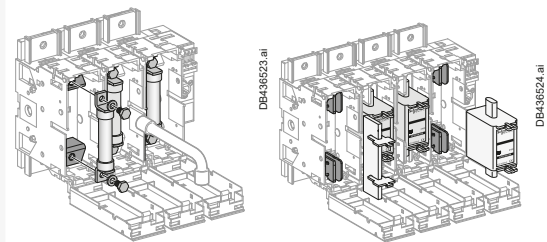
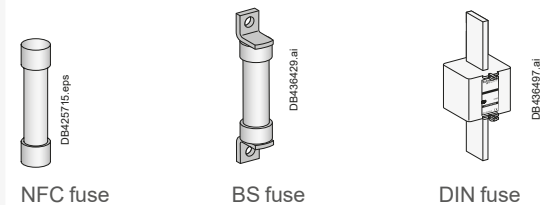
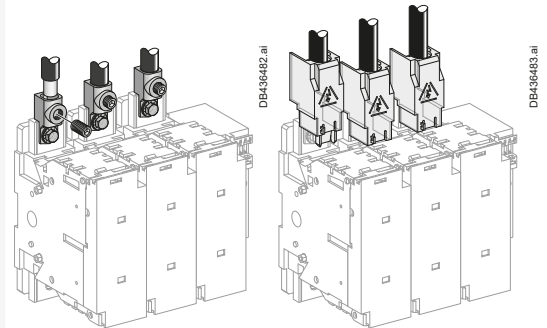

Detailed presentation

Presentation of the FuPacT GS range

FuPacT GSB and GSD 630, GSB and GSD 800

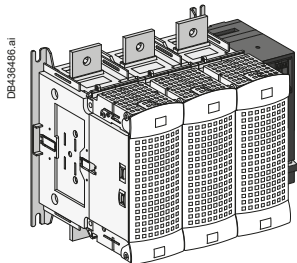

FuPacT GSB 630

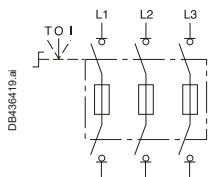

3 poles, 3 fuse-links

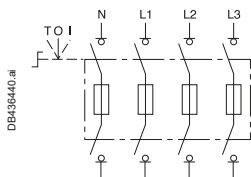

4 poles, 4 fuse-links

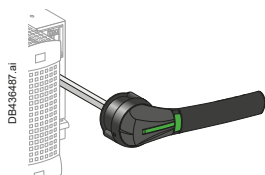

Extended front handles

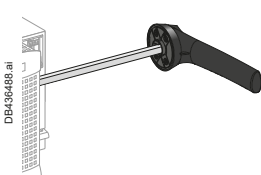

Extended lateral handles

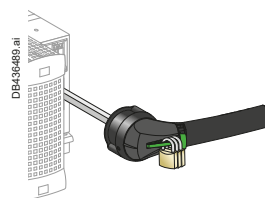
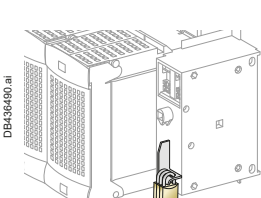
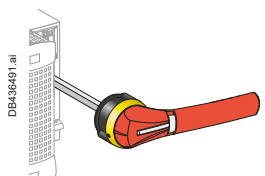
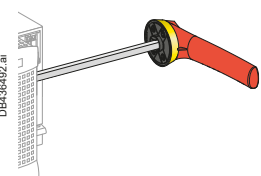
3 padlocks
on extended handle3 padlocks directly
on the deviceExtended front handles,
red handle on yellow frontExtended lateral handles,
red handle on yellow front

Functions

The FuPacT GSD and GSB 630, GSD and GSB 800 switch disconnecter fuses are used with fuses that protect electrical circuits against overloading and short circuits. They provide a circuit cut-off function by means of a double break upstream and downstream of the fuses.

They also provide a switch function allowing circuits to be cut-off when under load.

Format and installation

The GSD and GSB 630, GSD and GSB 800 devices are compact, optimizing the space used.

They consist of poles assembled and tested in factory as well as a housing for the control mechanism.

The transparent covers make it possible to see the presence or absence of fuses and their rating.

The devices are installed on a plate. The mounting points are incorporated into the products. There is no need to add accessories to fasten the products to a plate.

Note: The weight of the devices may require the intervention of 2 people when installing on a plate.

Number of poles

The devices are available as 3- or 4-pole versions cut-off by the open/close control. The 3P devices are fitted with 3 fuse holders, cut-off upstream and downstream of the fuse.

The 4P devices are fitted with 4 fuse holders, cut-off upstream and downstream of the fuse. One of the poles may be fitted with a neutral bar.

Controlling the devices

- The devices can be controlled in two ways:
 - By extended frontal control with a handle installed on the door of the electrical cabinet.
 - By extended lateral control with a handle installed on the side of the electrical cabinet.
- The control rods are available in 3 lengths: 200, 320 or 400 mm.

Note: They must be ordered separately.
- Several types of IP65 control handle are available and must be ordered separately
 - For frontal installation, black or yellow/red without test position.
 - For lateral installation, black or yellow/red without test position.
- The front handles allow the door to be interlocked with the control rod of the device. This prevents the opening of the door cabinet if the device is in the ON position.
- The lateral controls do not allow the door and the control rod to be interlocked. They must not be used as a frontal control.

Lockout system

The function whereby the devices can be locked in the OFF position is available on the direct control handle and the extended control handles.

It allows up to 3 padlocks to be fitted on each handle

It is also possible to padlock the devices on the control unit directly using the padlocking lug accessible on the front panel of the control unit. This lug can accommodate up to 3 padlocks.

Using the devices as emergency switch disconnecter fuse

The FuPacT switch disconnecters fuse can be used as emergency cut-off devices.

For this application, they must be easily visible, accessible and identifiable (see standards and rules: VDE 0660, VDE 0113, CNOMO, etc.).

For the purposes of easy identification, the emergency cut-off switch disconnecter fuse use special colors, as stipulated by the standards and different from those of the standard version:

- Yellow for the front face of the device or the control plate
- Red for the handle.

The performance characteristics of the FuPacT emergency cut-off switch disconnecter fuse are the same as those of the standard version.

Presentation of the FuPacT GS range

FuPacT GSB and GSD 630, GSB and GSD 800

Connecting the devices

The FuPacT GSD and GSB 630, GSD and GSB 800 devices are fitted with tin-plated terminal to connect directly conductors fitted with cable lugs or bars.

To facilitate rear connections, the connection terminal can be rotated.

In order to protect the direct contact connections, terminal covers may be used.

For FuPacT GSD and GSB 630, GSD and GSB 800:

- GS2AP73 (set of 3)
- GS2AP64 (set of 4).

Fuse type and installation

- GSD 630 and GSD 800 supports DIN 3 fuses compliant with IEC60269/ NFC63320 standards.
- GSB 630 and GSB 800 supports BS C2 and C3 fuses respectively compliant with IEC60269/BS88 standards.

Note: The fuses are not supplied with the devices.

- For FuPacT GSD 630 and 800, the fuses are installed by rotating the transparent protective cover, with the power supply switched off, then inserting the fuses in the fuse holders.
- For FuPacT GSB 630 and GSB 800, the fuses are installed by rotating the transparent protective cover, with the power supply switched off, then installing the fuses in the housings provided for this purpose. Manual tightening is strongly advised in order to comply with the recommended tightening torques (consult the device manual).

External neutral module and internal neutral bar

The DIN 630 and DIN 800A (LV481917) neutral links create a neutral connection in the device. The links are fitted instead of a fuse.

The external neutral modules are poles fitted with a removable neutral connection which is NOT CUT (no mechanism).

They are installed directly on the left-hand side of the product on the 3-pole device.

Cone guide

This accessory allows the control rod to be re-centred with regard to the hole drilled in the door. It is fitted to the door and serves to offset a drilling discrepancy or a bowing of the long rods of ± 10 mm.

Auxiliary contacts / Pre cut-off

FuPacT GSD and GSB 630, GSD and GSB 800 devices can be fitted with 8 auxiliary contacts enabling the mechanical position of the device to be indicated. 4 auxiliary contacts are fitted directly to the device (see manual) and 4 others can be stacked on top of the first ones.

The NO or NC auxiliary contacts thus allow the ON and OFF positions of the device to be indicated.

The auxiliary contacts also serve to indicate the pre cut-off of the device, as soon as the handle is activated but before the poles are opened.

This allows a charge to be stopped before cutting the main power supply.

- References GS1AM110 and GS1AM101 have 1 auxiliary contact (NO or NC) + 2 plastic tappets.
- References ZBE101 and ZBE102 are the auxiliary contacts alone.

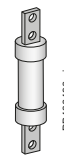
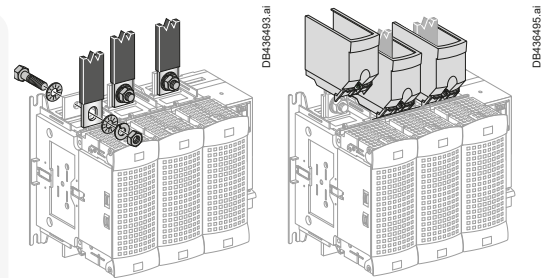

BS fuse

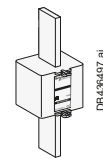

DIN fuse

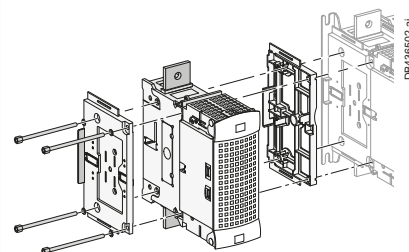
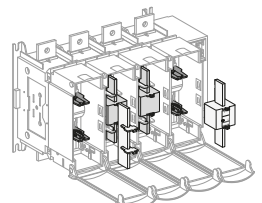
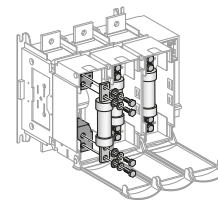

DIN link

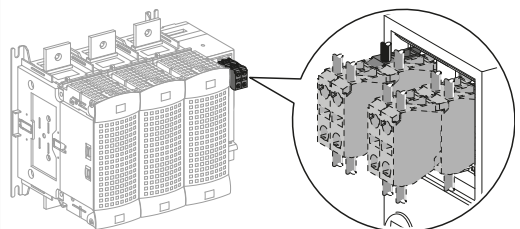

Detailed presentation

Presentation of the FuPacT GS range

FuPacT GSB and GSD 1250

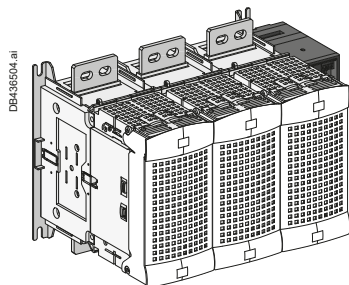

FuPacT GSB 1250

Functions

The FuPacT GSD and GSB 1250 A switch disconnecter fuses are used with fuses that protect electrical circuits against overloading and short circuits.

They provide a circuit cut-off function by means of a double break upstream and downstream of the fuses.

They also provide a switch function allowing circuits to be cut-off when under load.

Format and installation

The GSD and GSB 1250 A devices are compact, optimizing the space used.

They consist of poles assembled and tested in factory as well as a housing for the control mechanism

The transparent covers make it possible to see the presence or absence of fuses and their rating

The devices are installed on a plate. The mounting points are incorporated into the products. There is no need to add accessories to fasten the products to a plate.

Note: The weight of the devices may require the intervention of 2 people when installing on a plate.

Number of poles

The devices are available as 3- or 4-pole versions cut-off by the open/close control.

The 3P devices are fitted with 3 fuse holders, cut-off upstream and downstream of the fuse.

The 4P devices are fitted with 4 fuse holders, cut-off upstream and downstream of the fuse. One of the poles may be fitted with a neutral bar.

Controlling the devices

■ The devices can be controlled in two ways:

- By extended frontal control with a handle installed on the door of the electrical cabinet.
- By extended lateral control with a handle installed on the side of the electrical cabinet.

■ The control rods are available in 3 lengths: 200, 320 or 400 m.

Note: They must be ordered separately.

■ Several types of IP65 control handle are available and must be ordered separately

- For frontal installation, black or yellow/red without test position
- For lateral installation, black or yellow/red without test position

■ The frontal handles for the FuPacT GSD and GSB 1250 A devices are relatively wide dual-branch handles. Remember to provide for an installation allowing the control to be activated easily.

■ The front handles allow the door to be interlocked with the control rod of the device. This prevents the opening of the door cabinet if the device is in the ON position.

■ The lateral controls do not allow the door and the control rod to be interlocked. They must not be used as a frontal control.

Lockout system

The function whereby the devices can be locked in the OFF position is available on the direct control handle and the extended control handles.

It allows up to 3 padlocks to be fitted on each handle.

It is also possible to padlock the devices on the control unit directly using the padlocking lug accessible on the front panel of the control unit. This lug can accommodate up to 3 padlocks.

Using the devices as emergency switch disconnecter fuse

The FuPacT switch disconnecters fuse can be used as emergency cut-off devices.

For this application, they must be easily visible, accessible and identifiable (see standards and rules: VDE 0660, VDE 0113, CNOMO, etc.).

For the purposes of easy identification, the emergency cut-off switch disconnecter fuse use special colors, as stipulated by the standards and different from those of the standard version:

- Yellow for the front face of the device or the control plate
- Red for the handle.

The performance characteristics of the FuPacT emergency cut-off switch disconnecter fuse are the same as those of the standard version.

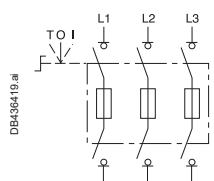

3 poles, 3 fuse-links

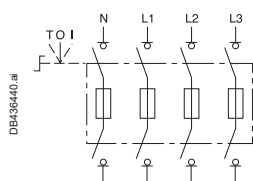

4 poles, 4 fuse-links

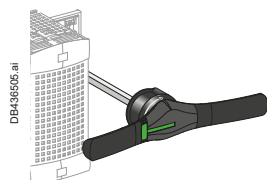

Extended front handles

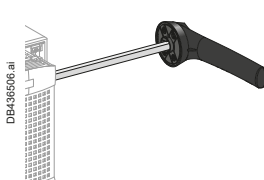

Extended lateral handles

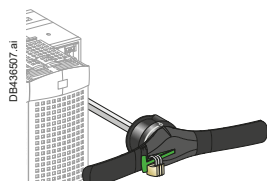

3 padlocks on extended handle

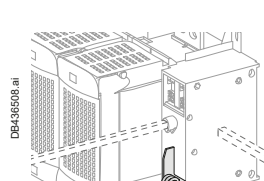

3 padlocks directly on the device

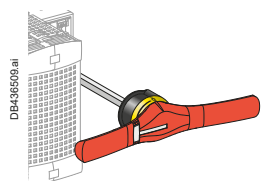

Extended front handles, red handle on yellow front

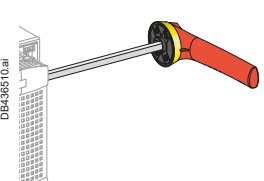

Extended lateral handles, red handle on yellow front

Presentation of the FuPacT GS range

FuPacT GSB and GSD 1250

Connecting the devices

The FuPacT GSD and GSB 1250 A devices are fitted with tin-plated terminal to connect directly conductors fitted with cable lugs or bars.

To facilitate rear connections, the connection terminal can be rotated.

In order to protect connections from direct contact, terminal covers may be used.

For FuPacT GSD and GSB 1250 A:

- GS2AP83 (set of 3)
- GS2AP84 (set of 4).

Fuse type and installation

- The GSD 1250 supports DIN 4 fuses compliant with IEC60269/NFC63320 standards
- The GSB 1250 devices support BS D1 fuses compliant with IEC60269/BS88 standards.

Note: The fuses are not supplied with the devices.

- For FuPacT GSD 1250, the fuses are installed by rotating the transparent protective cover, with the power supply switched off, then inserting the fuses in the fuse holders. The fuse holder terminal must be tightened for correct installation of the fuses
- For FuPacT GSB 1250, the fuses are installed by rotating the transparent protective cover, with the power supply switched off, then installing the fuses in the housings provided for this purpose. Manual tightening is strongly advised in order to comply with the recommended tightening torques (consult the device manual).

External neutral module and internal neutral link

The DIN 1250A (LV481918) neutral links create a neutral connection in the device. The links are fitted instead of a fuse.

The external neutral modules are poles fitted with a removable neutral connection which is NOT CUT (no mechanism).

They are installed directly on the left-hand side of the product on the 3-pole device.

Cone guide

This accessory allows the control rod to be re-centred with regard to the hole drilled in the door. It is fitted to the door and serves to offset a drilling discrepancy or a bowing of the long rods of ± 10 mm.

Auxiliary contacts / Pre cut-off

FuPacT GSD and GSB 1250A devices can be fitted with 8 auxiliary contacts enabling the mechanical position of the device to be indicated.

4 auxiliary contacts are fitted directly to the device (see manual) and 4 others can be stacked on top of the first ones.

The NO or NC auxiliary contacts thus allow the ON and OFF positions of the device to be indicated

The auxiliary contacts also serve to indicate the pre cut-off of the device, as soon as the handle is activated but before the poles are opened.

This allows a charge to be stopped before cutting the main power supply.

- References GS1AM110 and GS1AM101 have 1 auxiliary contact (NO or NC) + 2 plastic tappets.
- References ZBE101 and ZBE102 are the auxiliary contacts alone.

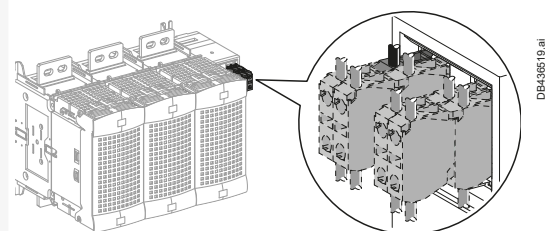
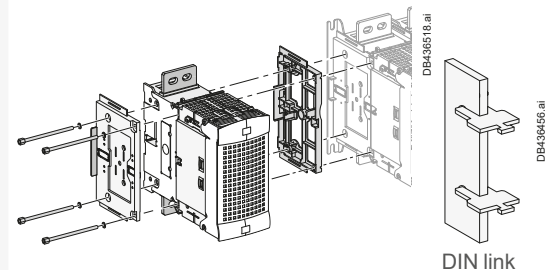
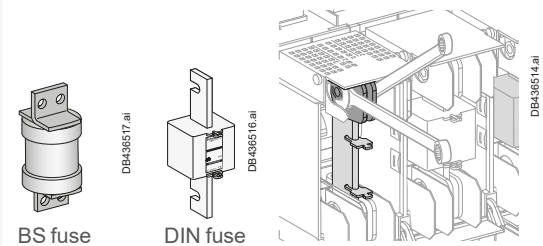
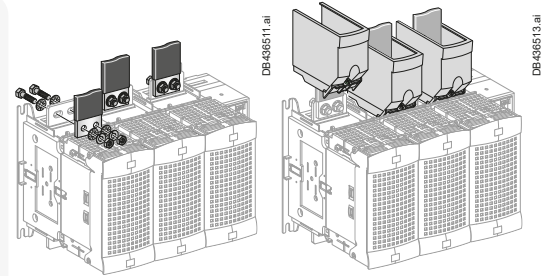

FuPacT GS 32 A

Dimensions

Dimensions

GSC 32 A with direct front handle

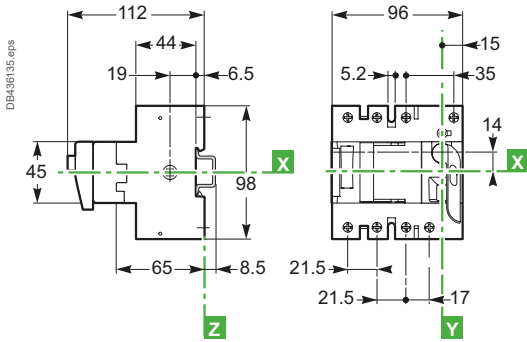

GSB 32 A with direct front handle

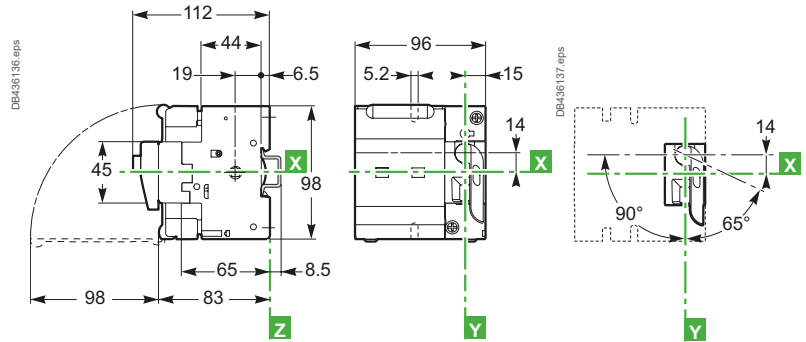

GSC 32 A with extended front handle

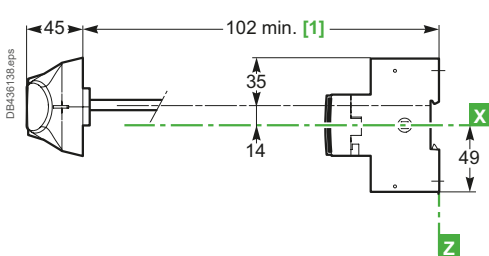

GSB 32 A with extended front handle

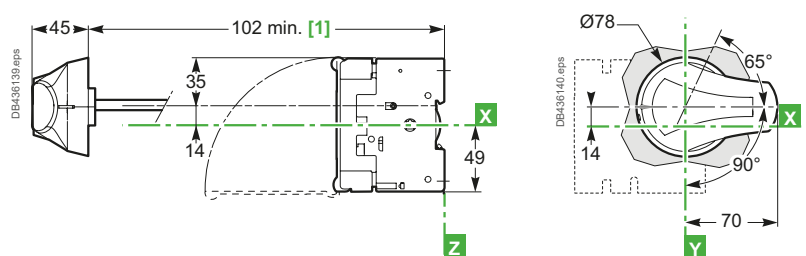

[1] With 1 or 2 auxiliary contacts GS1 AM1●●: 130 mm.
With 3 or 4 auxiliary contacts GS1 AM1●●: 155 mm.

GSC 32 A with extended lateral handle

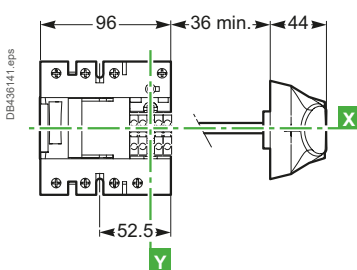

GSB 32 A with extended lateral handle

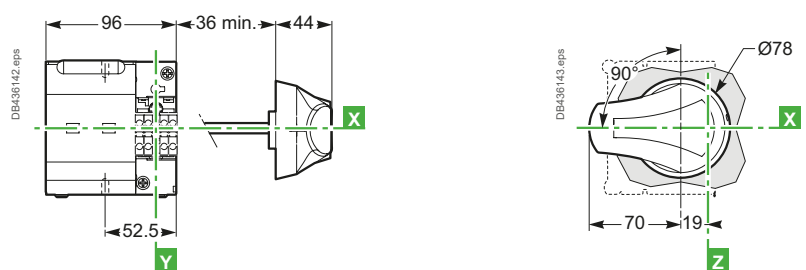

Dimensions and connection

FuPacT GS 32 A

Mounting and front panel cut-outs

Mounting

On the backplate

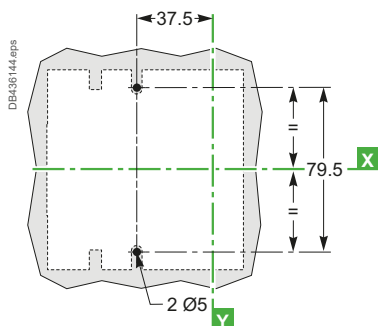

On DIN rail

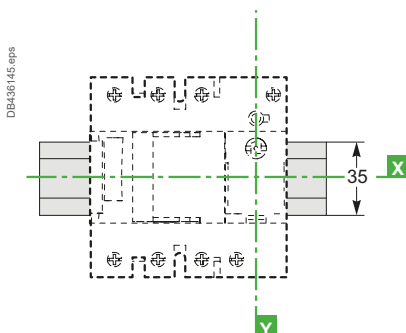

Front panel cut-outs

Extended front handle

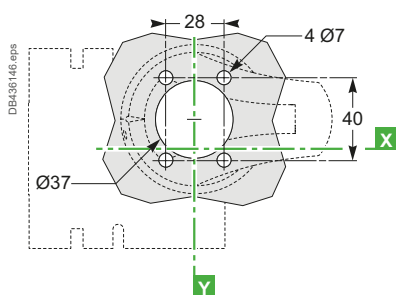

Extended lateral handle

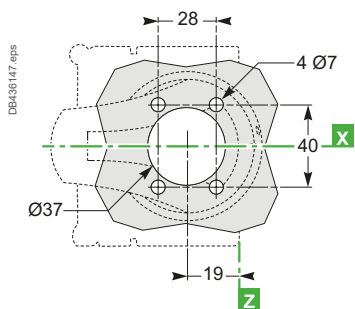

Accessories

Auxiliary contacts

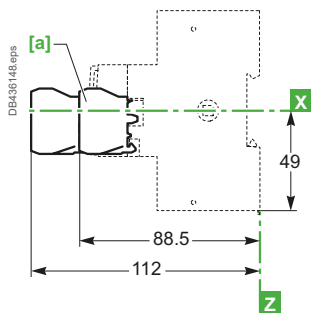

[c] 1 to 4 auxiliary contacts GS1 AM1●●.



Dimensions and connection

FuPacT GS 50/63 A

Dimensions

Dimensions

Direct front handle

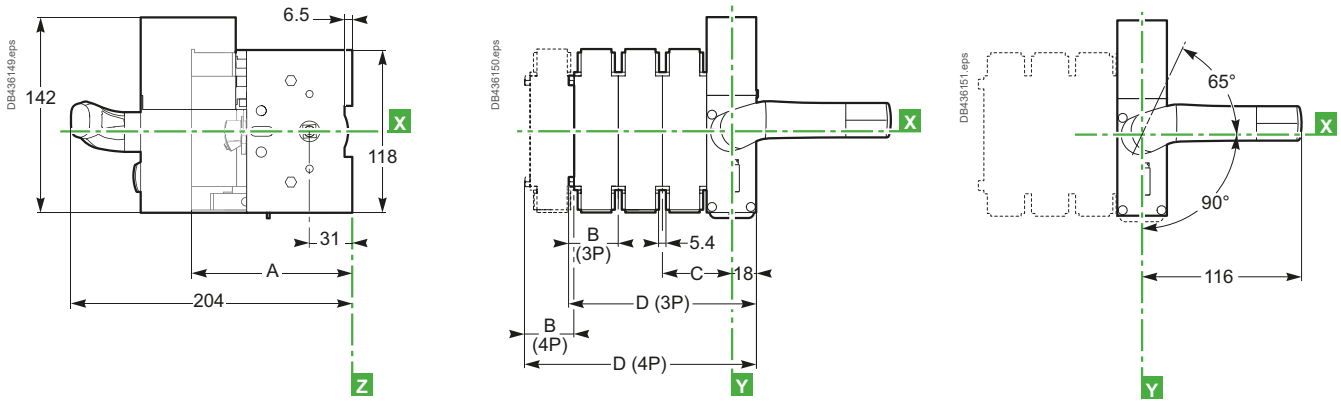

Extended front handle



[1] FuPacT GS 50 A : 1 auxiliary contact GS1 AM1●●: E + 23.5 mm, 2 auxiliary contacts GS1 AM1●●: E + 47 mm.

Extended lateral handle

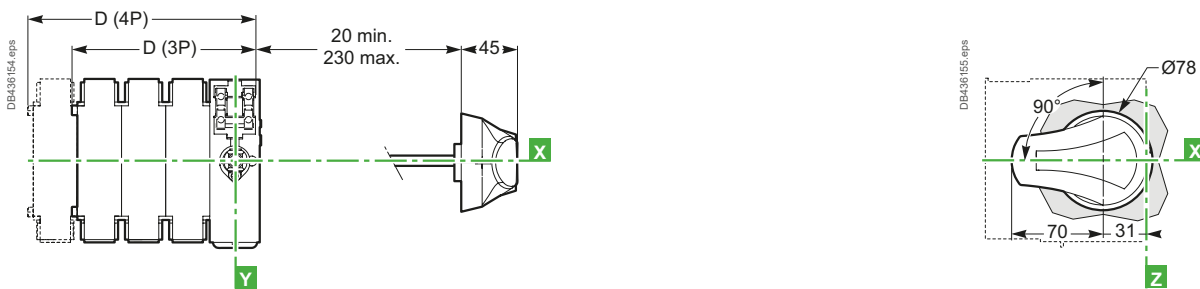

Type		A	B	C	D	E min.	F	G	H	I
GSC 50 A	3P	87	31	45	121	100	27	110.5	134	31
	4P	87	31	45	148	100	54	110.5	134	-
GSB/GSD 63 A	3P	116.5	36	50	136	139	32	108.5	132	36
	4P	116.5	36	50	168	139	64	108.5	132	-

Dimensions and connection

FuPacT GS 50/63 A

Mounting and front panel cut-outs

Mounting

On the backplate

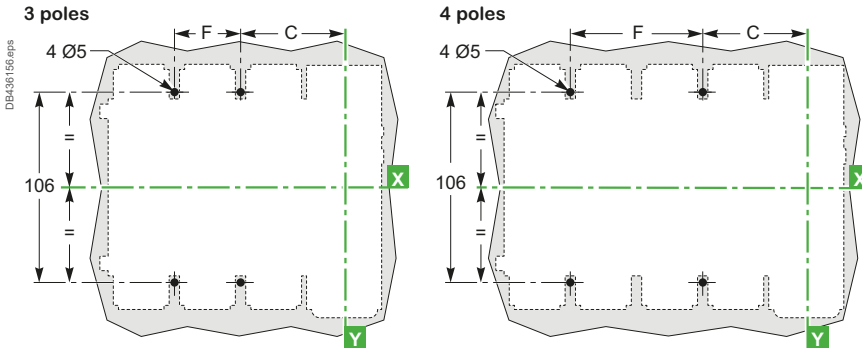

On DIN rail

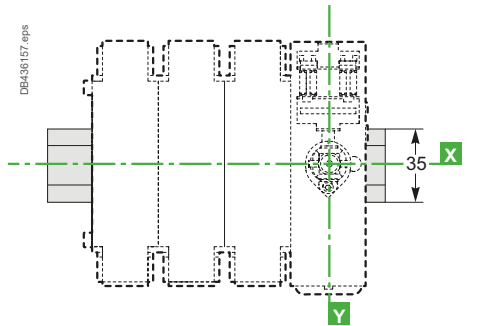

Front panel cut-outs

Extended front handle

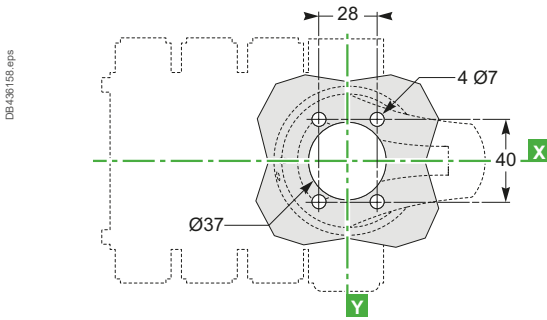

Extended lateral handle

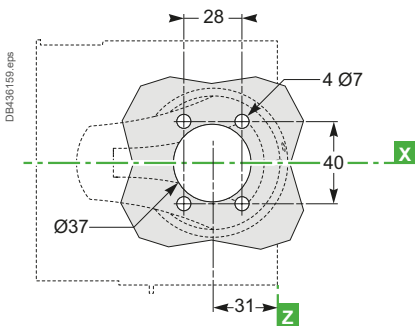

Accessories

Auxiliary contacts

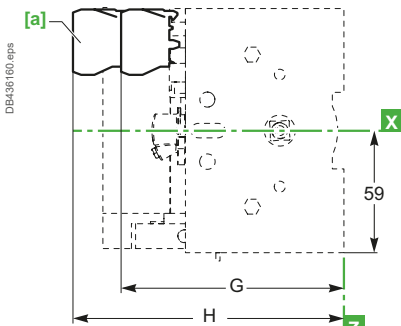

External neutral module

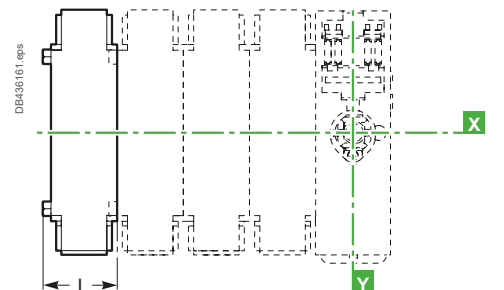

[c] 1 to 4 auxiliary contacts GS1 AM1●●.

Type		A	B	C	D	E min.	F	G	H	I
GSC 50 A	3P	87	31	45	121	100	27	110.5	134	31
	4P	87	31	45	148	100	54	110.5	134	-
GSB/GSD 63 A	3P	116.5	36	50	136	139	32	108.5	132	36
	4P	116.5	36	50	168	139	64	108.5	132	-

FuPacT GS 100/160 A

Dimensions

Dimensions

Direct front handle

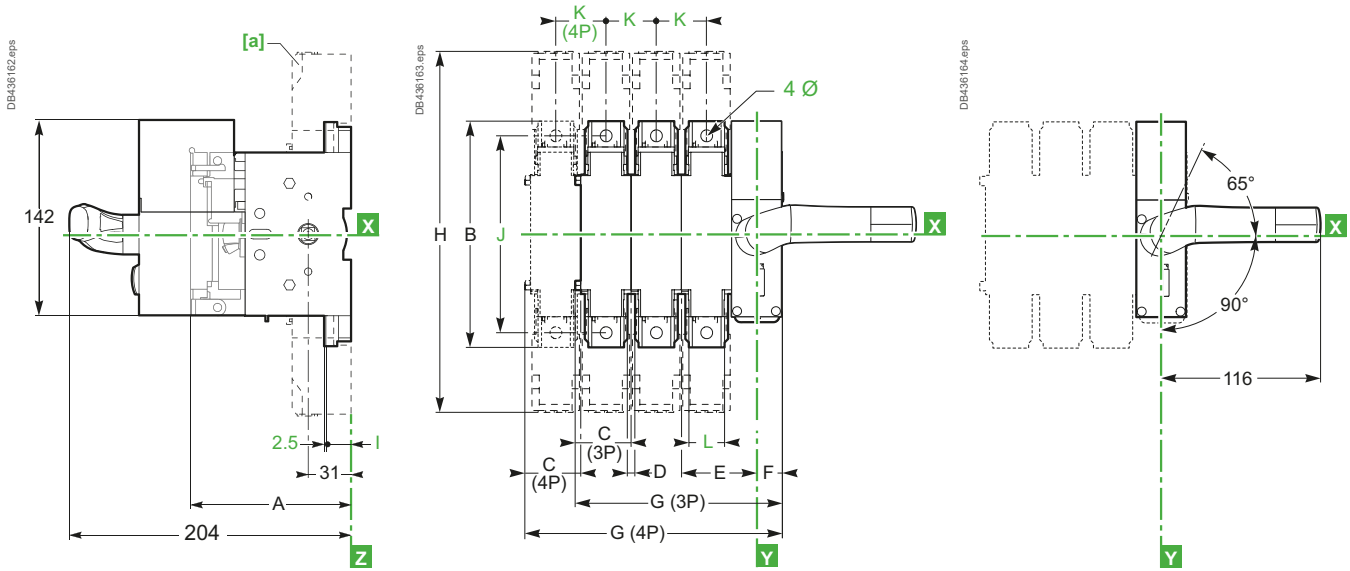

[a] Terminal cover.

Extended front handle



Extended lateral handle

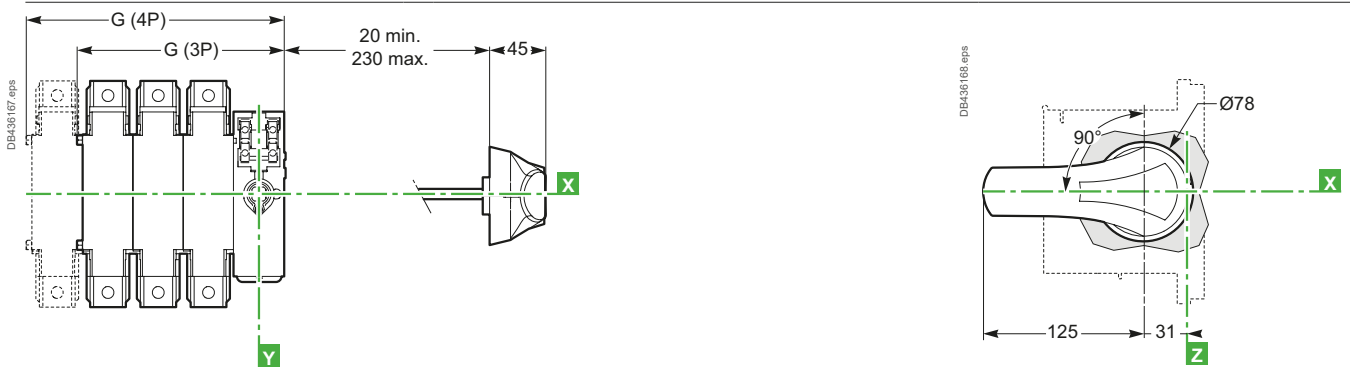

Type		A	B	C	D	E min.	F	G	H	I	J	K	L	Ø	M min.	N
GSB 100 A	3P	116	162	40	5.4	54	18	148	268	19.5	141	36	20	8.5	135	81
	4P	116	162	40	5.4	54	18	184	268	19.5	141	36	20	8.5	135	81
GSC 125 A	3P	116	162	40	5.4	54	18	148	268	19.5	141	36	20	8.5	135	81
	4P	116	162	40	5.4	54	18	184	268	19.5	141	36	20	8.5	135	81
GSD 125 A	3P	126.5	162	40	5.4	54	18	148	268	19.5	141	36	20	8.5	135	81
	4P	126.5	162	40	5.4	54	18	184	268	19.5	141	36	20	8.5	135	81
GSD 160 A	3P	126.5	162	40	5.4	54	18	148	268	19.5	141	36	20	8.5	135	81
	4P	126.5	162	40	5.4	54	18	184	268	19.5	141	36	20	8.5	135	81
GSB 160 A	3P	136.5	162	54	5.4	64	18	190	268	19.5	141	50	20	8.5	145	81
	4P	136.5	162	54	5.4	64	18	240	268	19.5	141	50	20	8.5	145	81

Dimensions and connection

FuPacT GS 100/160 A

Mounting and front panel cut-outs

Mounting

On the backplate

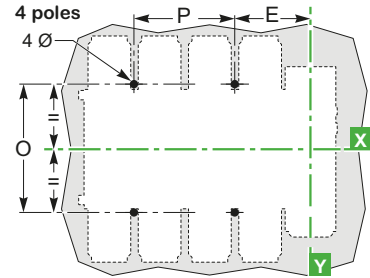
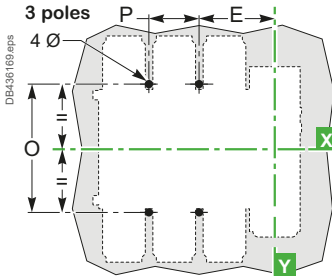

Front panel cut-outs

Extended front handle

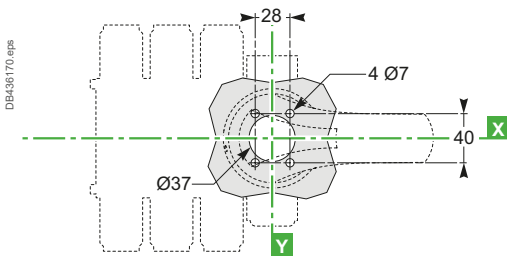

Extended lateral handle

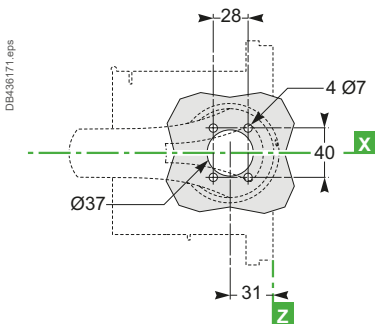

Accessories

Auxiliary contacts

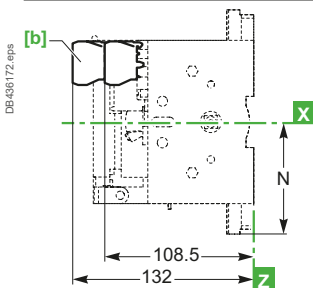

[b] 1 to 4 auxiliary contacts GS1 AM1●●.

External neutral module

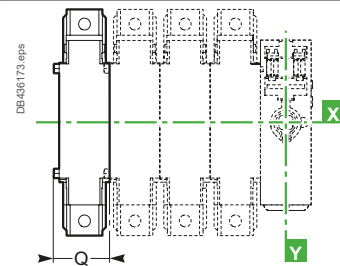

Type		E	O	P	Ø	Q
GSB 100 A	3P	54	127	36	5	40
	4P	54	127	72	5	-
GSC 125 A	3P	54	127	36	5	40
	4P	54	127	72	5	-
GSD 125 A	3P	54	127	36	5	40
	4P	54	127	72	5	-
GSD 160 A	3P	54	127	36	5	40
	4P	54	127	72	5	-
GSB 160 A	3P	64	140	50	5	54
	4P	64	140	100	5	-



FuPacT GS 200/400 A

Dimensions

Dimensions

Direct front handle

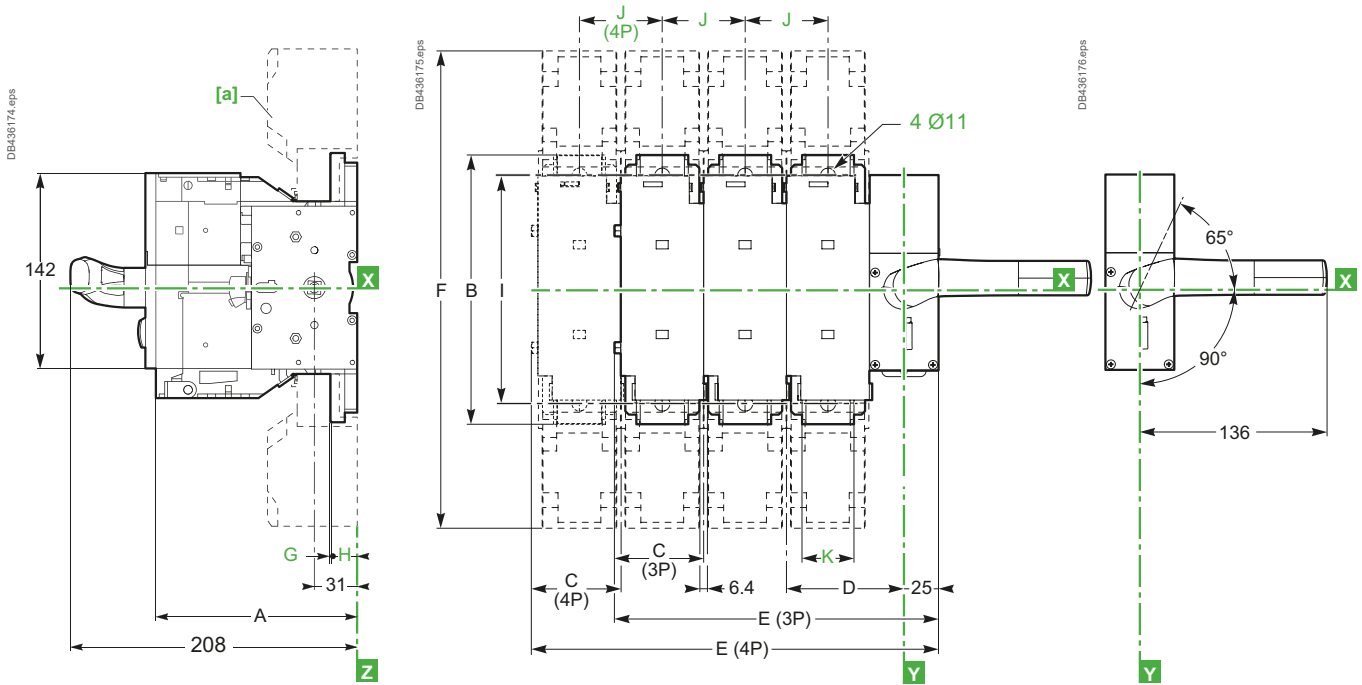

[a] Terminal cover.

Extended front handle

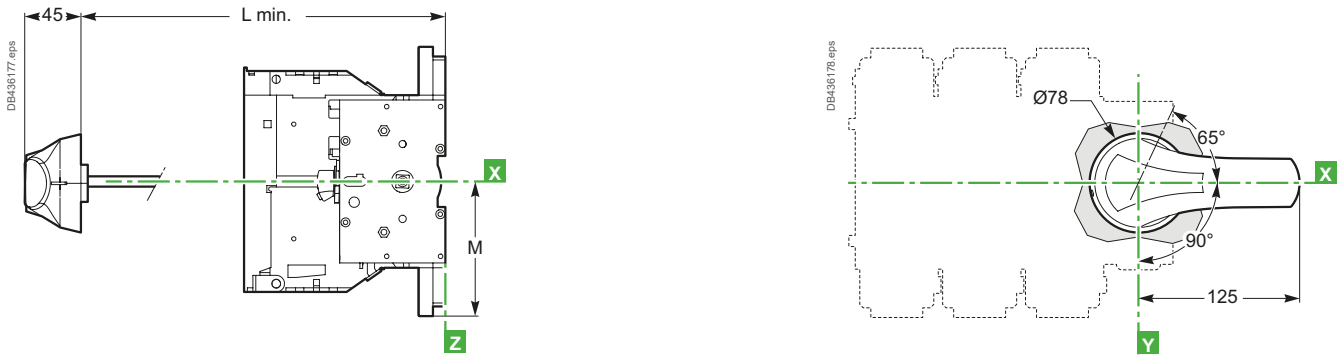

Extended lateral handle

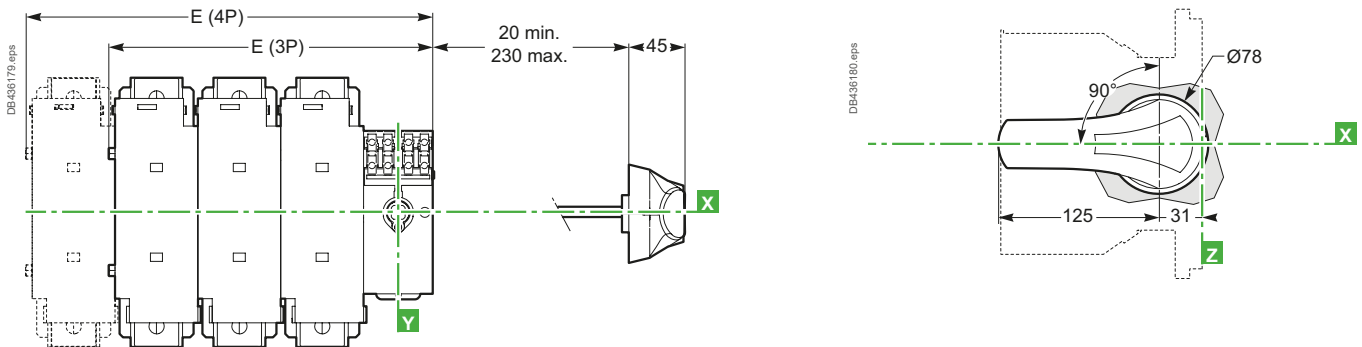

Type		A	B	C	D	E	F	G	H	I	J	K	L min.	M	N	O	P
GSB 200 A	3P	146	195	64	86	234	345	2.5	19.5	166	60	32	154	97.5	162	60	64
	4P	146	195	64	86	294	345	2.5	19.5	166	60	32	154	97.5	162	120	-
GS 250 A	3P	146	195	64	86	234	345	2.5	19.5	166	60	32	154	97.5	162	60	64
	4P	146	195	64	86	294	345	2.5	19.5	166	60	32	154	97.5	162	120	-
GS 400 A	3P	149	205	70	91	252	355	3	20	175	66	50	157	102.5	172	66	70
	4P	149	205	70	91	318	355	3	20	175	66	50	157	102.5	172	132	-

Dimensions and connection

FuPacT GS 200/400 A

Mounting and front panel cut-outs

Mounting

On the backplate

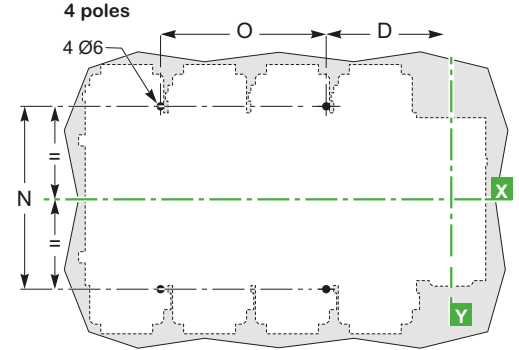
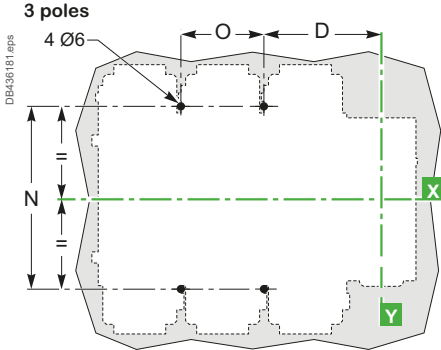

Front panel cut-outs

Extended front handle

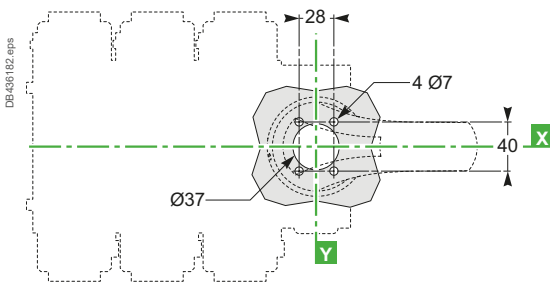

Extended lateral handle

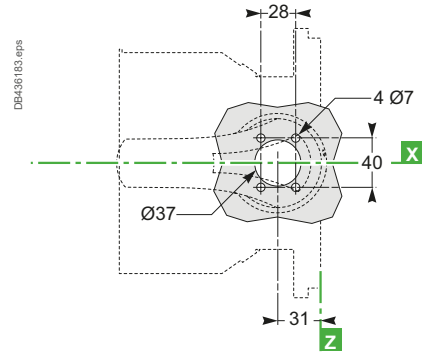

Accessories

Auxiliary contacts

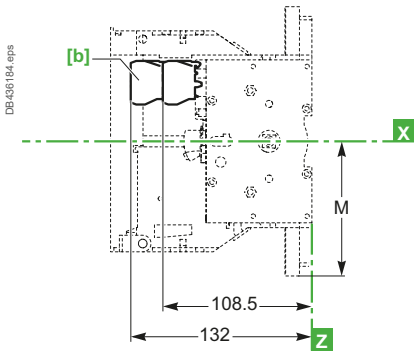

External neutral module

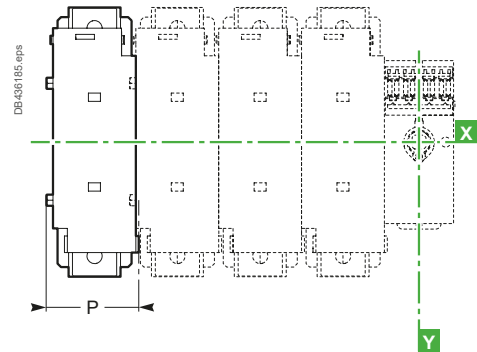

[b] 1 to 8 auxiliary contacts GS1 AM1●●.
1 to 4 auxiliary contacts GS1 AM1●● with direct front handle.

Type	A	B	C	D	E	F	G	H	I	J	K	L min.	M	N	O	P	
GSB 200 A	3P	146	195	64	86	234	345	2.5	19.5	166	60	32	154	97.5	162	60	64
	4P	146	195	64	86	294	345	2.5	19.5	166	60	32	154	97.5	162	120	-
GS 250 A	3P	146	195	64	86	234	345	2.5	19.5	166	60	32	154	97.5	162	60	64
	4P	146	195	64	86	294	345	2.5	19.5	166	60	32	154	97.5	162	120	-
GS 400 A	3P	149	205	70	91	252	355	3	20	175	66	50	157	102.5	172	66	70
	4P	149	205	70	91	318	355	3	20	175	66	50	157	102.5	172	132	-

FuPacT GS 630/800 A

Dimensions

Dimensions

GSB 630 A / GSD 630 A / GSB 800 A / GSD 800 A

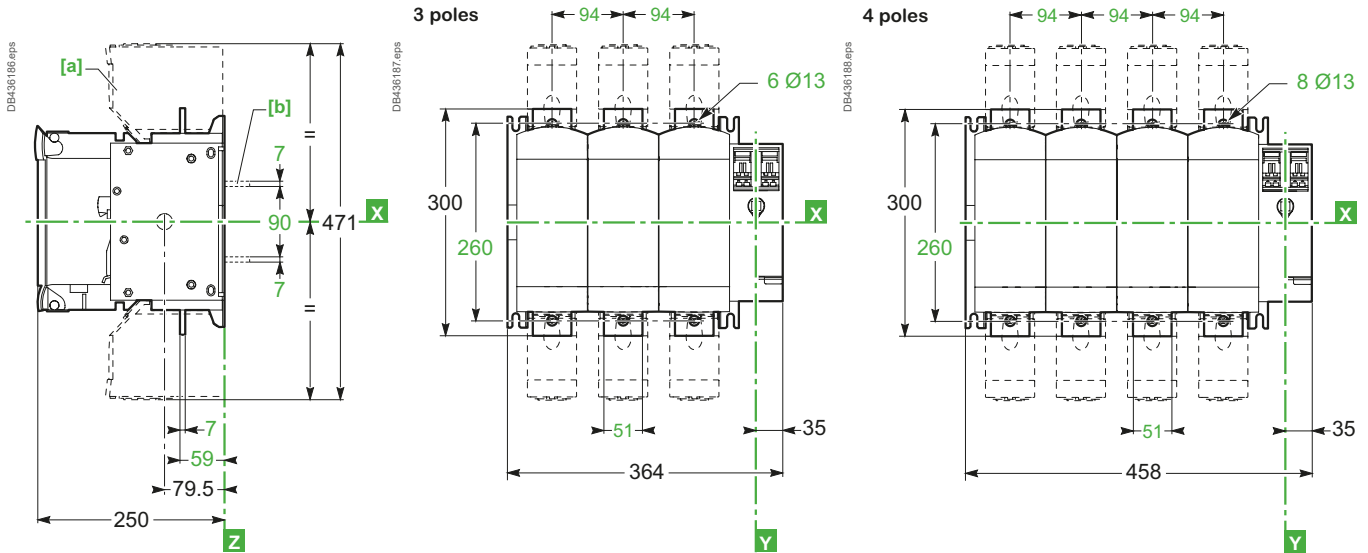

[a] Terminal cover.
[b] Rear access connector plates.

Extended front handle

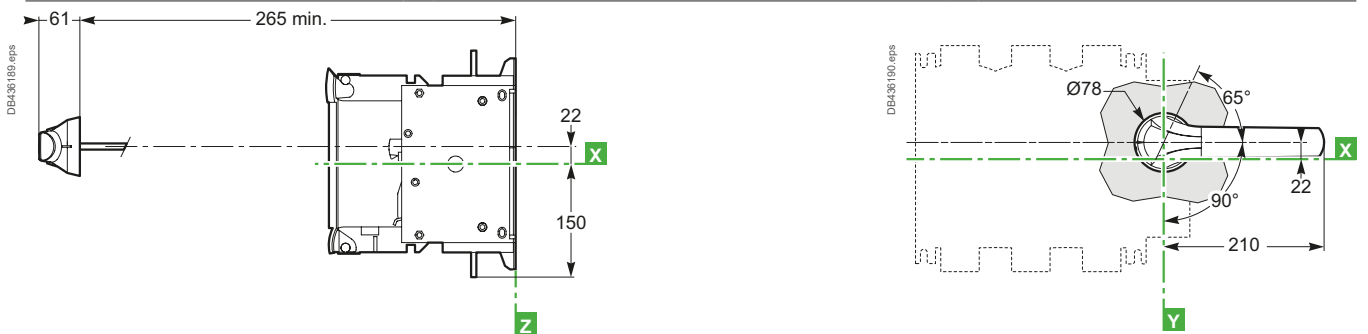

Extended lateral handle

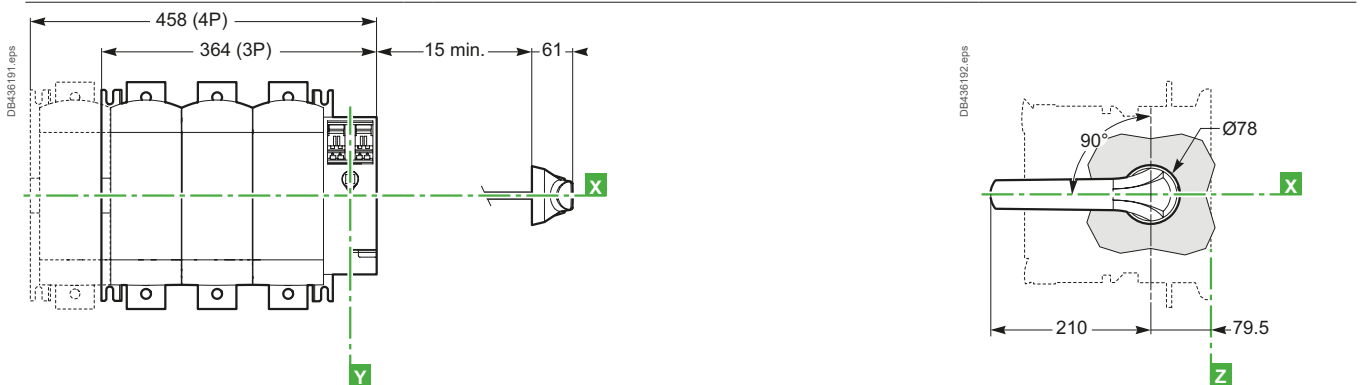

Dimensions and connection

FuPacT GS 630/800 A

Mounting and front panel cut-outs

Mounting

On the backplate

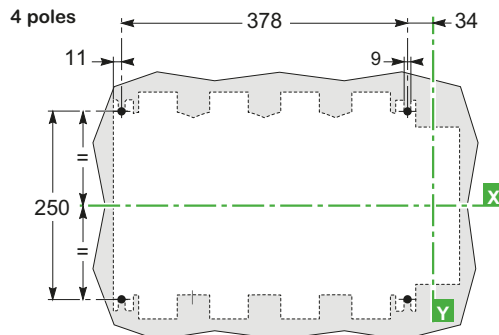
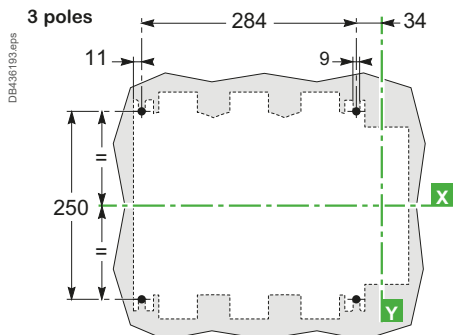

Front panel cut-outs

Extended front handle

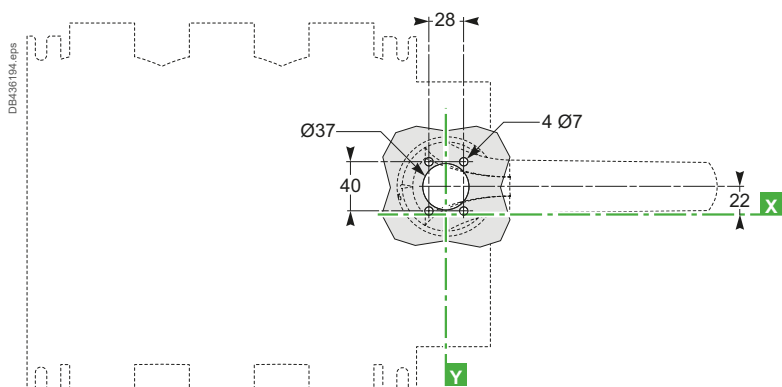

Extended lateral handle

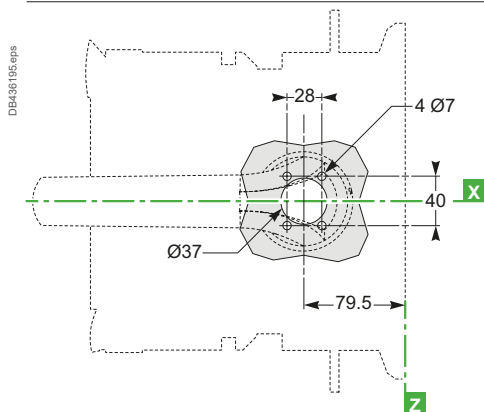

Accessories

Auxiliary contacts

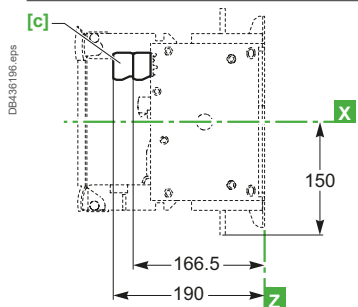

[c] 1 to 8 auxiliary contacts GS1 AM1●●.

External neutral module

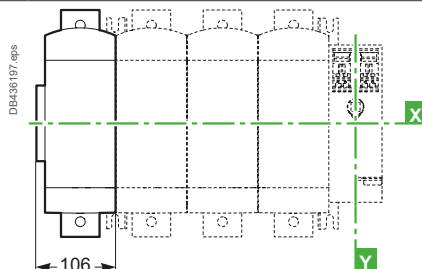

FuPacT GS 1250 A

Dimensions

Dimensions

GSB 1250 A / GSD 1250 A

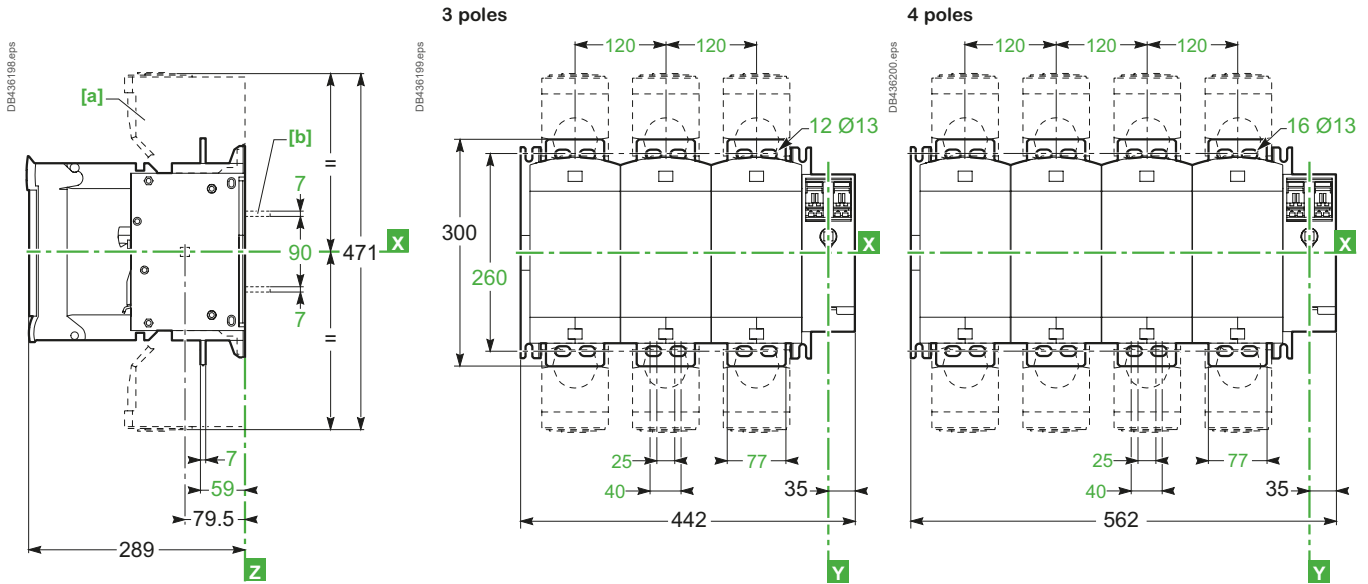

- [a] Terminal cover.
- [b] Rear access connector plates.

Extended front handle

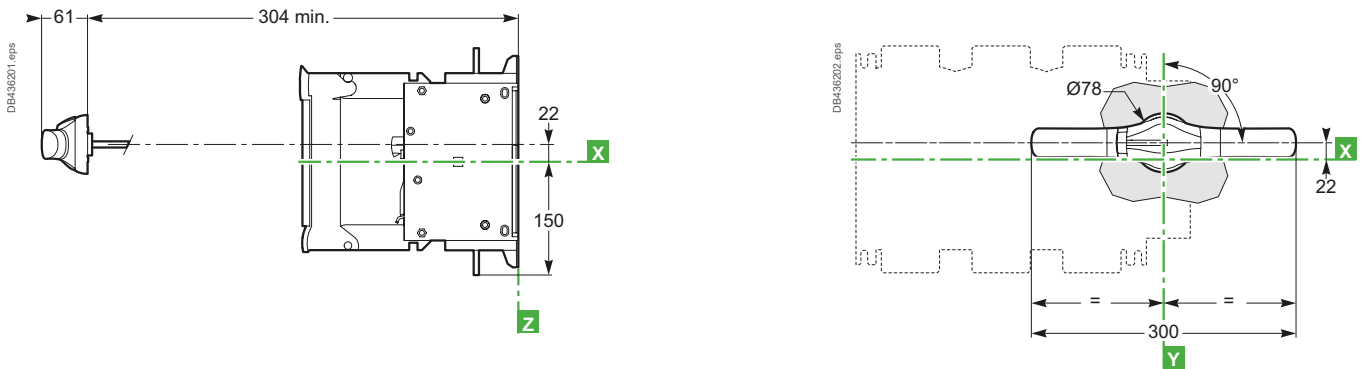

Extended lateral handle

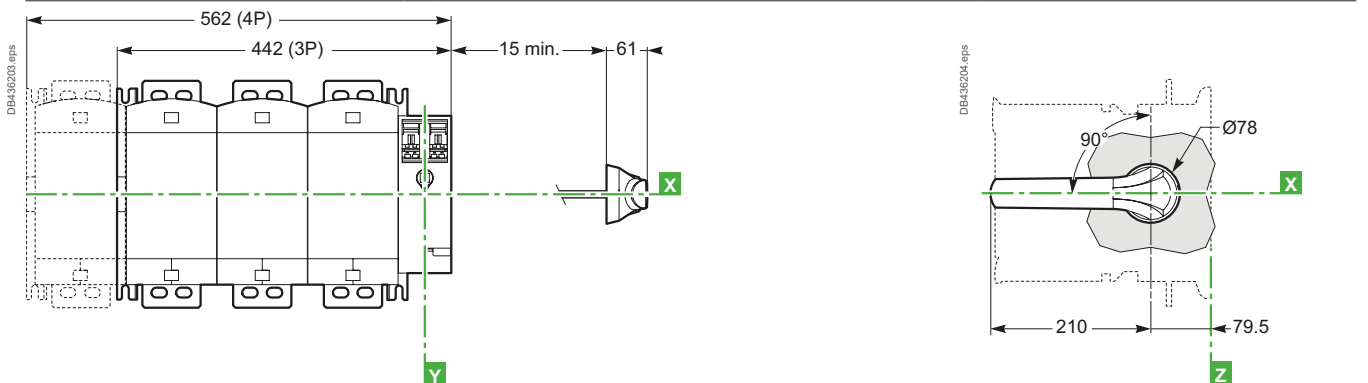

Dimensions and connection

FuPacT GS 1250 A

Mounting and front panel cut-outs

Mounting

On the backplate

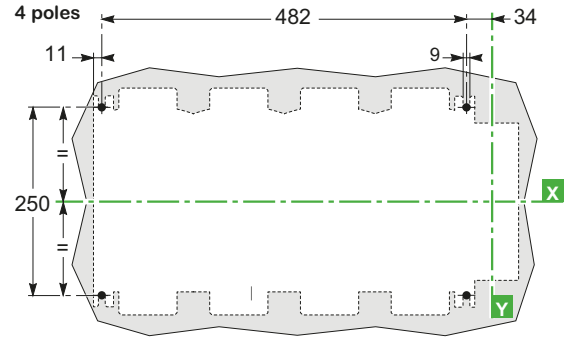
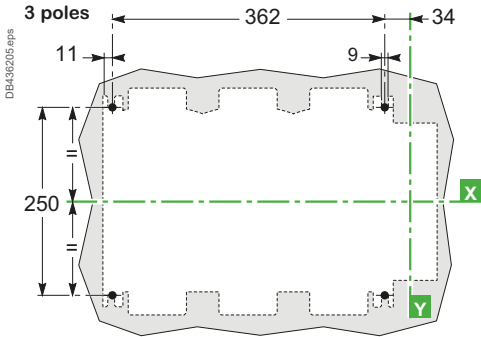

Front panel cut-outs

Extended front handle

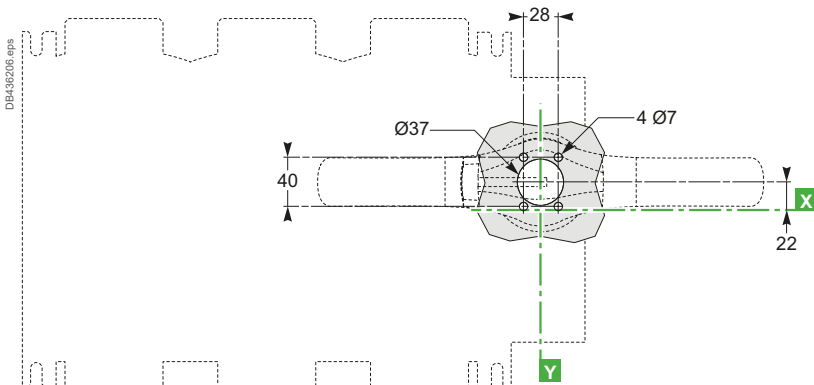

Extended lateral handle

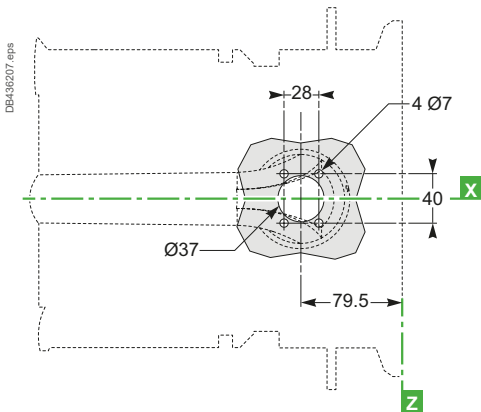

Accessories

Auxiliary contacts

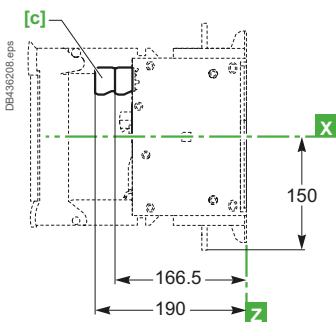

[c] 1 to 8 auxiliary contacts GS1 AM1●●.

External neutral module

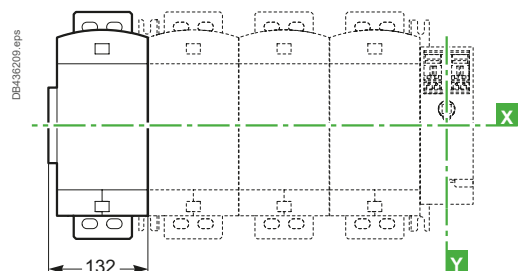

FuPacT GS 32 to 1250 A

Class II installation

Minimum Air distance to respect between the protective screen and the plastic covers of fuses in a Class II installation

GS 32 A

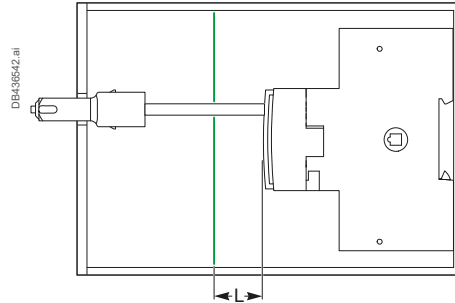

Reference	L min.
LV481503	35
LV481504	
LV481603	
LV481604	

GS 50 A / GS 63 A / GS 100 A / GS 125 A / GS 160 A

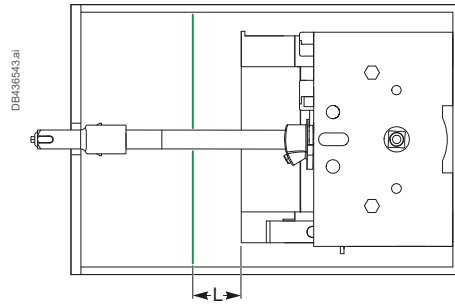

Reference	L min.
LV481513	40
LV481514	
LV481403	
LV481404	
LV481613	
LV481614	
LV481623	35
LV481624	
LV481413	
LV481414	
LV481523	
LV481524	
LV481633	
LV481634	
LV481423	
LV481424	



Dimensions and connection

FuPacT GS 32 to 1250 A

Class II installation

Minimum Air distance to respect between the protective screen and the plastic covers of fuses in a Class II installation

GS 200 A / GS 250 A / GS 400 A

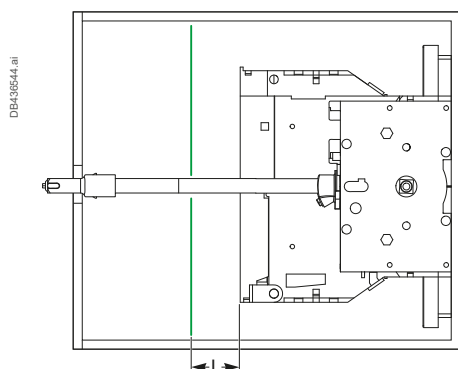

Reference	L min.
LV481643	32
LV481644	
LV481653	
LV481654	
LV481663	
LV481664	
LV481433	
LV481434	
LV481443	
LV481444	

GS 630 A / GS 800 A / GS 1250 A

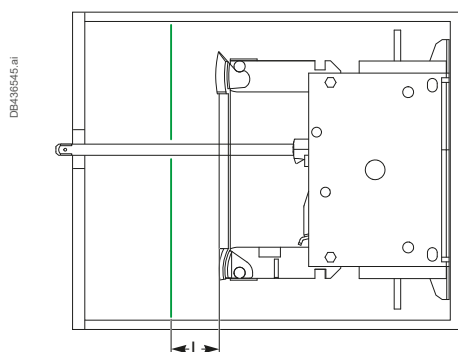

Reference	L min.
LV481453	30
LV481454	
LV481463	
LV481464	
LV481673	
LV481674	
LV481683	
LV481684	
LV481693	
LV481694	
LV481473	
LV481474	

Mounting Options

Switch-disconnector fuse	FuPacT GS● CD 32	FuPacT GS● 50 to 63	FuPacT GS● 100 to 160	FuPacT GS● 200 to 1250
DIN rail	●	not available	not available	not available
Mounting plate	●	●	●	●
Slotted plate	not available	●	●	●
Vertical positions	●	●	●	●
Lateral positions	●	●	●	●
Horizontal positions	●	●	●	●





Catalog numbers

ISFT100N	D-2
Devices and accessories	D-2
ISFT100	D-3
Devices and accessories	D-3
ISFT160	D-4
Devices and accessories	D-4
ISFT250 to ISFT630	D-5
Devices and accessories	D-5
ISFL160	D-6
Devices and accessories	D-6
ISFL250 to ISFL1250	D-8
Devices and accessories	D-8
GSC32 - GSC50 - GSC125	D-10
Devices	D-10
Accessories	D-11
GSD 63 to 1250	D-12
Devices	D-12
Accessories	D-13
GSB 32 to 1250	D-14
Devices	D-14
Accessories	D-15



Other chapters	
Presentation.....	2
FuPacT ISFT.....	A-1
FuPacT ISFL.....	B-1
FuPacT GS.....	C-1

ISFT100N

Devices and accessories

ISFT100N 3P fixed front-connected

Basic device for mounting on a backplate

Connection via 2.5 to 50 mm² cable connectors

LV480750

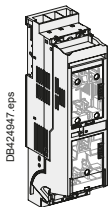

Basic device for mounting on busbars

Hook-on connection to 60 mm busbars

Upstream distribution

LV480751

Downstream distribution

LV480752

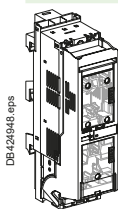

Accessories

DIN rail fixing kit

LV480753

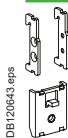

Support profile laterally attachable

Set of 2

LV480754

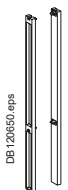

Terminal shield

Set of 2

LV480756

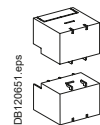

Electrical auxiliaries

Auxiliary changeover contact NO + NC

LV480841

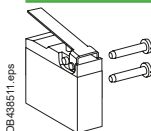

ISFT100 3P fixed front-connected

Basic device for mounting on a backplate

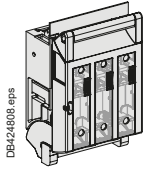

Connection via 1.5 to 50 mm² cable connectors

LV480800

Accessories

Mounting accessories

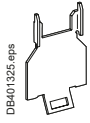

Accessory for mounting on a DIN rail

49877

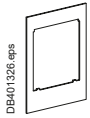

Escutcheon (not compatible with feeding busbars)

For 1 device
 For 2 devices

49878

49879

Connection accessories

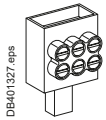

Distribution connector 3 x 16 mm²

Set of 3

49860

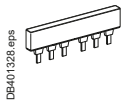

Feeding busbar to supply 2 devices

49861

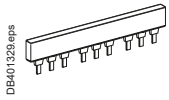

Feeding busbar to supply 3 devices

49862

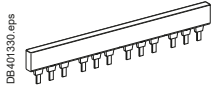

Feeding busbar to supply 4 devices

49863



Incoming connector (25 to 95 mm²) for feeding busbars

Set of 3

49865

Electrical auxiliaries

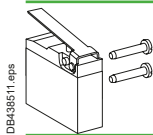

Auxiliary changeover contact NO + NC

LV480841



ISFT160

Devices and accessories

ISFT160 3P fixed front-connected

Basic device for mounting on a backplate

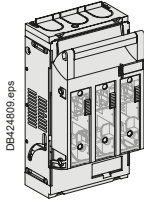

M8 terminals	LV480801
2,5 to 95 mm ² cable connectors (box clamp)	LV480802

Basic device for mounting on busbars with turnable hooks

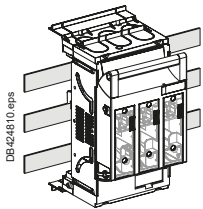

ISFT160	LV480803
---------	----------

Accessories

Mounting accessories

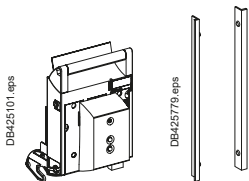

Handle with electronic fuse monitor	LV480810
-------------------------------------	----------

Support profile laterally attachable	LV480817
--------------------------------------	----------

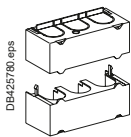

Terminal shields (set of one shield per reference)	LV480819
----------------------------------------------------	----------

Connection accessories



Incoming connector	LV480818
--------------------	----------

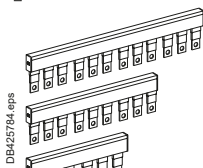

Feeding busbars	for 2 devices	LV480811
	for 3 devices	LV480812
	for 4 devices	LV480813

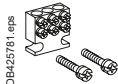

Distribution connector 3 x 16 mm ² for 1,5 to 50 mm ² cable connectors	LV480814
----------------------------------------------------------------------------------------------	----------



Pressure plate for multiple-use terminal from 6 to 50mm ²	LV480815
----------------------------------------------------------------------	----------

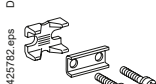

Pressure plate with contact prism for multiple-use terminal with Cu/Alu conductors from 6 to 70 mm ²	LV480816
-----------------------------------------------------------------------------------------------------------------	----------

Electrical auxiliaries

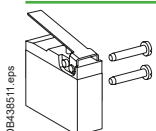

Auxiliary changeover contact NO+NC	LV480841
------------------------------------	----------

Catalog numbers

ISFT250 to ISFT630

Devices and accessories

ISFT250 to ISFT630 3P fixed front-connected

Basic device for mounting on a backplate

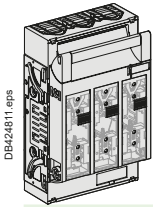

ISFT250	LV480804
ISFT400	LV480806
ISFT630	LV480808

Basic device for mounting on busbars with turnable hooks

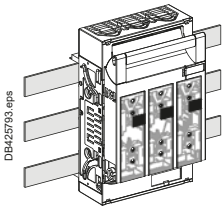

ISFT250	LV480805
ISFT400	LV480807

Accessories

Mounting accessories

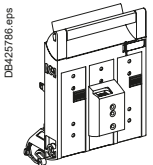

Handle with electronic fuse monitor	ISFT250	LV480821
	ISFT400	LV480825
	ISFT630	LV480828

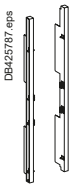

Support profile laterally attachable	LV480832
--------------------------------------	----------

Connection accessories

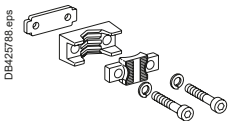

Pressure plate with contact prism for multiple-use terminal with Cu/Al conductors (3 sets per reference)	from 70 to 150 mm ²	ISFT250	LV480822
	from 120 to 240 mm ²	ISFT400	LV480826
	from 150 to 300 mm ²	ISFT630	LV480829



ISFT250 box clamp from 35 to 150 mm ² 35...150 mm ² re/rm 50 to 150 mm ² se/sm (3 sets per reference)	LV480823
----------------------------------------------------------------------------------------------------------------------------------------------	----------

ISFT400 and ISFT 630 box clamp 95...300 mm ² re/rm 120 to 300 mm ² se/sm (3 sets per reference)	LV480830
-----------------------------------------------------------------------------------------------------------------------------	----------

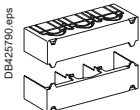

Terminal shields (set of one shield per reference)	ISFT250	LV480824
	ISFT400	LV480827
	ISFT630	LV480831

Electrical auxiliaries

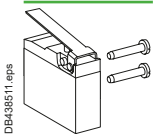

Auxiliary changeover contact NO + NC	LV480841
--------------------------------------	----------



ISFL160

Devices and accessories

ISFL160 1-pole switchable fixed front-connected

Basic device for mounting on busbars

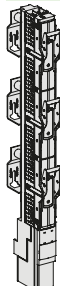
	Direct connection to 185mm busbars (M12)		LV480900

ISFL160 3-pole switchable fixed front-connected

Basic device for mounting on busbars

	Direct hook-on connection to 60 mm busbars	Screws M8	LV480850
		Terminals 95 mm ²	LV480851
	Direct connection to 100 mm busbars	Screws M8	LV480852
		Terminals 95 mm ²	LV480853



Conversion kit for connection to busbars (for ISFL160 direct connection)

	Direct connection to 185 mm busbars	LV480854
	Direct connection to 185 mm busbars for 2 ISFL160 devices	LV480855

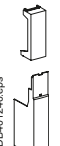
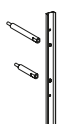
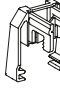

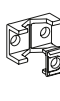

Accessories

	Sideframe door cut out - 850 mm	LV480868
	Sidewise angle bracket for side frame (x4)	LV480869
	Length adaptor	LV480870
	Empty plastic box (46 x 46 mm)	LV480878
	Bank panel cover	LV480871
	Contact hooks for ISFL 1-pole switchable	Set of 3 LV480905

Connection (accessories for standard M8 terminals)

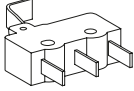
	Lugs for 95 mm ² copper cables	Set of 3	28951
	Connectors for Cu/Al bare cables 1.5 x 95 mm ²	Set of 3	LV480861
	Connectors for flexible bars 12 x 6 mm	Set of 3	LV480862
			

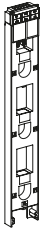
Electrical auxiliaries

 DB401245.eps	Auxiliary changeover contact NO + NC	LV480873
 DB419492.eps	1 current transformer for ISFL 1-pole switchable	150/5 A class 1 5 VA Set of 1 LV480904
 DB401246.eps	Single block with 3 current transformer for ISFL 3-pole switchable	150/5 A class 1 1.5 VA 150/1 A class 1 2.5 VA Set of 1 Set of 1 LV480881 LV480882
 DB401217.eps	Single block with current transformer for ISFL 3-pole switchable	150/5 A class 1 1.5 VA 150/1 A class 1 2.5 VA Set of 1 Set of 1 LV480883 LV480884
 DB401217.eps	Fuse monitor for ISFL 3-pole switchable	LV480877



Catalog numbers

ISFL250 to ISFL1250

Devices and accessories

ISFL250 to ISFL630 1-pole switchable

Basic device for mounting on busbars

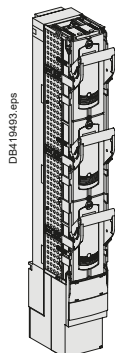

Direct connection to 185 mm busbars (screw M12)

ISFL250	LV480901
ISFL400	LV480902
ISFL630	LV480903

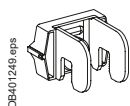

Hooks for mounting without drilling

LV480859

ISFL250 to ISFL630 3-pole switchable

Basic device for mounting on busbars

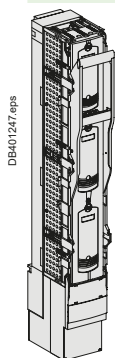

Direct connection to 185 mm busbars

ISFL250	LV480856
ISFL400	LV480857
ISFL630	LV480858
ISFL1250	LV480875

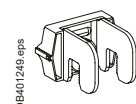

Hooks for mounting without drilling

LV480859

With fuse monitor

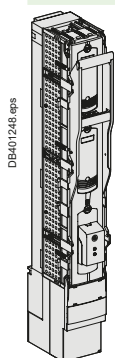

Fuse monitor (direct connection to 185 mm busbars)





ISFL250	LV480863
ISFL400	LV480864
ISFL630	LV480865
ISFL1250	LV480876

Catalog numbers



ISFL250 to ISFL1250

Devices and accessories

Accessories

		Sideframe door cut out - 850 mm			LV480868
		Sidewise angle bracket for side frame	Set of 4		LV480869
		Empty plastic box (72 x 72 mm)			LV480879 ^[1]
		Empty plastic box (96 x 96 mm)			LV480880 ^[1]
		Blank panel cover			LV480872

Connection (accessories for standard M12 terminals)

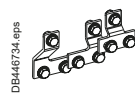
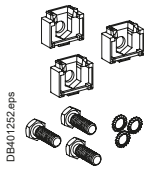
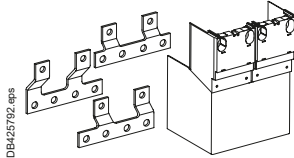
		Connectors	For Cu/Al bare cable 1 x 35 to 300 mm ²	Set of 3	LV480867 ^[1]
			For Cu/Al bare cable 2 x 50 to 185 mm ²	Set of 3	49895 ^[1]
			For Cu/Al cable 4 x 240 mm ²	Set of 3	LV480890 ^[2]
			For Cu/Al cable 2 x 300mm ²	Set of 2	LV480892
					
		Screws with plastic support		Set of 3	LV480866 ^[1]
		Coupling kit ISFL250-630			LV480891 ^[1]

Electrical auxiliaries

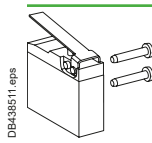
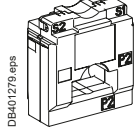
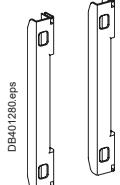
		Auxiliary changeover contact NO + NC			LV480841
	Current transformer	150/5 class 1	2.5 VA	Set of 1	LV480885
		250/5 class 1	5 VA	Set of 1	LV480886
		400/5 class 1	5 VA	Set of 1	LV480887
		600/5 class 1	5 VA	Set of 1	LV480888
		Click-lock cable transformers		Set of 1	LV480889

[1] Except for ISFL1250.
 [2] Only for ISFL1250.

Catalog numbers

GSC32 - GSC50 - GSC125

Devices

GSC32 - GSC50 - GSC125

Basic Device : Front or lateral control

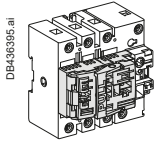

Switch/Type of fuse

GSC32 / NFC
(10 x 38), 32 A

3P/3F

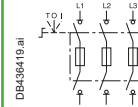

LV481503

4P/3F+N

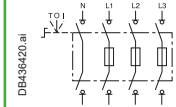

LV481504

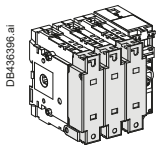

Switch/Type of fuse

GSC50 / NFC
(14 x 51), 50 A
GSC125 / NFC
(22 x 58), 125 A

3P/3F

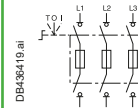

LV481513

4P/4F

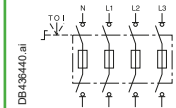

LV481514

LV481523

LV481524

Direct handle with Test position

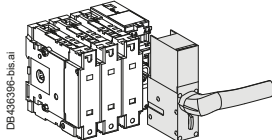
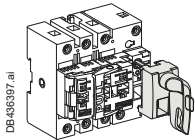

Front

32 A

GS1AH103

50 and 125 A

LV481701 ^[1]

Extended Rotary Handle IP 65

Front handle

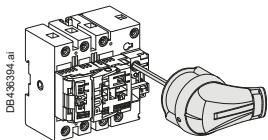

Front Black Handle

Front Red/Yellow Handle

Front Black Handle + test position

Front Red/Yellow Handle + test position

32 and 50 A

GS2AH510

GS2AH520

GS2AHT510

GS2AHT520

125 A

GS2AH530

GS2AH540

GS2AHT530

GS2AHT540

Lateral handle

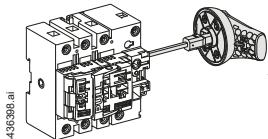

Lateral Black Handle

Lateral Red/Yellow Handle

32 and 50 A

GS2AH210

GS2AH220

125 A

GS2AH230

GS2AH240

Accessories

Shaft

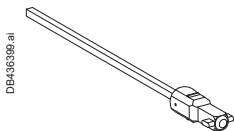

200 mm shaft

320 mm shaft

400 mm shaft

32 and 50 A

GS2AE82

GS2AE8

GS2AE81

125 A

GS2AE22

GS2AE2

GS2AE21

Guide cone

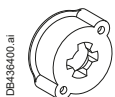

32 to 1250 A

GS2AEH12

[1] Available Q4 2020.

Accessories - GSC32 - GSC50 - GSC125

Connection

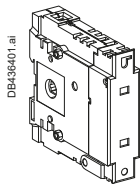

External neutral module	For GSC50	LV481900
	For GSC125	LV481902

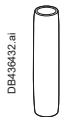

Internal neutral link	For GSC50	LV481911
	For GSC125	LV481912

Electrical auxiliaries (Compatible with all GSC products)

Auxiliary contacts

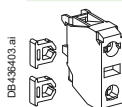

1 NO contact with 2 accessories	GS1AM110
1 NC contact with 2 accessories	GS1AM101

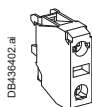

Set of 5 NO contacts	ZBE101
Set of 5 NC contacts	ZBE102

Cable connectors



For GSC125	3P (set of 3)	4P (set of 4)
	GS1AW33	GS1AW34

Terminal shield

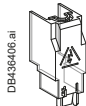

For GSC125	3P (set of 3)	4P (set of 4)
	GS1AP33	GS1AP34

Note: FuPacT GS and its accessories are not compatible with the FuPacT INF former range.

Catalog numbers

GSD 63 to 1250

Devices

GSD63 - GSD125 - GSD160 - GSD250 - GSD400 - GSD630 - GSD800 - GSD1250

Basic Device : Front or lateral control

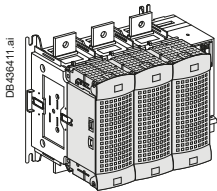
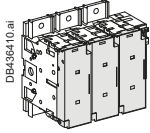

Switch/Type of fuse	3P/3F	4P/4F
GSD63/DIN 000 63 A	 LV481403	 LV481404
GSD125/DIN 00 125 A	LV481413	LV481414
GSD160/DIN 00 160 A	LV481423	LV481424
GSD250/DIN 1 250 A	LV481433	LV481434
GSD400/DIN 2 400 A	LV481443	LV481444
GSD630/DIN 3 630 A	LV481453	LV481454
GSD800/DIN 3 800 A	LV481463	LV481464
GSD1250/DIN 4 1250 A	LV481473	LV481474

Direct handle with Test position

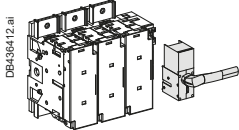

	63 to 160 A	250 to 400 A	630 to 800 A	1250 A
Front	LV481701 ^[1]	LV481702 ^[1]	-	-

Extended Rotary Handle IP 65

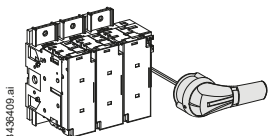

Front handle	63 A	125 to 400 A	630 to 800 A	1250 A
Front Black Handle	GS2AH510	GS2AH530	GS2AH550	GS2AH570
Front Red/Yellow Handle	GS2AH520	GS2AH540	GS2AH560	GS2AH580
Front Black Handle + test position	GS2AHT510	GS2AHT530	-	-
Front Red/Yellow Handle + test position	GS2AHT520	GS2AHT540	-	-

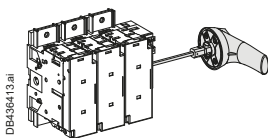

Lateral handle	63 A	125 to 400 A	630 to 1250 A
Lateral Black Handle	GS2AH210	GS2AH230	GS2AH250
Lateral Red/Yellow Handle	GS2AH220	GS2AH240	GS2AH260

Accessories

Shaft

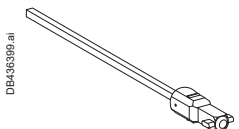

	63 to 400 A	630 to 1250 A
200 mm shaft	GS2AE22	GS2AE52
320 mm shaft	GS2AE2	GS2AE5
400 mm shaft	GS2AE21	GS2AE51

Guide cone

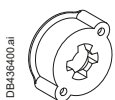

	63 to 1250 A
	GS2AEH12

^[1] Available Q4 2020.

Note: FuPacT GS and its accessories are not compatible with the FuPacT INF former range.

Accessories - GSD63 - GSD125 - GSD160 - GSD250 - GSD400 - GSD630 - GSD800 - GSD1250

Connection

	External neutral module	For GSD63	LV481901
		For GSD100 to GSD160	LV481902
		For GSD200 to GSD250	LV481904
		For GSD400	LV481905
		For GSD630 to GSD800	LV481906
	For GSD1250	LV481907	
	Internal neutral link	For GSD63 to GSD160	LV481913
		For GSD250	LV481915
		For GSD400	LV481916
		For GSD630 to GSD800	LV481917
		For GSD1250	LV481918

Electrical auxiliaries (Compatible with all GSD products)

Auxiliary contacts

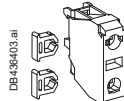
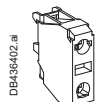
	1 NO contact with 2 accessories	GS1AM110
	1 NC contact with 2 accessories	GS1AM101
	Set of 5 NO contacts	ZBE101
	Set of 5 NC contacts	ZBE102

Cable connectors

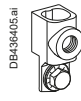
	For GSD100 to GSD160	3P (set of 3) GS1AW33	4P (set of 4) GS1AW34
	For GSD200 to GSD250	GS1AW43	GS1AW44
	For GSD400	LV481203	LV481204

Terminal shield ^[1]

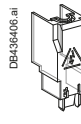
	For GSD125 to GSD160	3P (set of 3) GS1AP33	4P (set of 4) GS1AP34
	For GSD250 to GSD400	GS1AP43	GS1AP44
	For GSD630 to GSD 800	GS2AP73	GS2AP64
	For GSD1250	GS2AP83	GS2AP84

[1] The use of terminal shields is mandatory at 690 V AC.

Note: FuPacT GS and its accessories are not compatible with the FuPacT INF former range.

Catalog numbers

GSB 32 to 1250

Devices

GSB32 - GSB63 - GSB100 - GSB160 - GSB200 - GSB250 - GSB400 - GSB630 - GSB800 - GSB1250

Basic Device : Front or lateral control

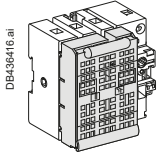

Switch/Type of fuse	3P/3F	4P/3F+N
GSB32 - BS A1 32A	DB436419.ai	DB436420.ai
	LV481603	LV481604

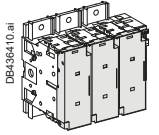

Switch/Type of fuse	3P/3F	4P/4F
GSB63 - BS A2/A3 63A	DB436419.ai	DB436440.ai
GSB100 - BS A4 100A	LV481623	LV481624
GSB160 - BS A4 160A	LV481633	LV481634
GSB200 - BS B1/B2 200A	LV481643	LV481644
GSB250 - BS B1/B2/B3 250A	LV481653	LV481654
GSB400 - BS B1/B2/B3/B4 400A	LV481663	LV481664

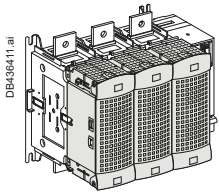

GSB630 - BS C2 630A	LV481673	LV481674
GSB800 - BS C3 800A	LV481683	LV481684
GSB1250 - BS D1 1250A	LV481693	LV481694

Direct handle with Test position

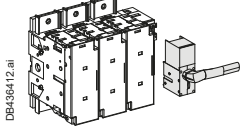

	32 A	63 to 160 A	200 to 400 A
Front	GS1AH103	LV481701 [1]	LV481702 [1]

Extended Rotary Handle IP 65

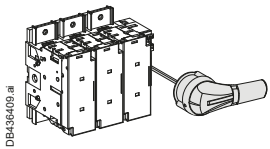

Front handle	32 to 63 A	125 to 400 A	630 to 800 A	1250 A
Front Black Handle	GS2AH510	GS2AH530	GS2AH550	GS2AH570
Front Red/Yellow Handle	GS2AH520	GS2AH540	GS2AH560	GS2AH580
Front Black Handle + test position	GS2AHT510	GS2AHT530	-	-
Front Red/Yellow Handle + test position	GS2AHT520	GS2AHT540	-	-

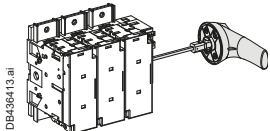

Lateral handle	63 A	125 to 400 A	630 to 1250 A
Lateral Black Handle	GS2AH210	GS2AH230	GS2AH250
Lateral Red/Yellow Handle	GS2AH220	GS2AH240	GS2AH260

[1] Available Q4 2020.

Note: FuPacT GS and its accessories are not compatible with the FuPacT INF former range.

Accessories

Shaft

DB436399.ai

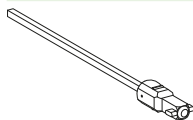

	32 A	63 to 400 A	630 to 1250 A
200 mm shaft	GS2AE82	GS2AE22	GS2AE52
320 mm shaft	GS2AE8	GS2AE2	GS2AE5
400 mm shaft	GS2AE81	GS2AE21	GS2AE51

Guide cone

DB436400.ai



	63 to 1250 A
	GS2AEH12

Accessories - GSB32 - GSB63 - GSB100 - GSB160 - GSB200 - GSB250 - GSB400 - GSB630 - GSB800 - GSB1250

Connection

DB436414.ai

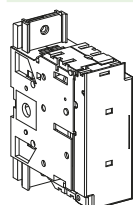

External neutral module		
	For GSB63	LV481901
	For GSB100	LV481902
	For GSB160	LV481903
	For GSB200 - GSB250	LV481904
	For GSB400	LV481905
	For GSB630 - GSB800	LV481906
	For GSB1250	LV481907

Electrical auxiliaries (Compatible with all GSB products)

Auxiliary contacts

DB436403.ai

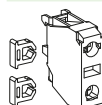

1 NO contact with 2 accessories	GS1AM110
1 NC contact with 2 accessories	GS1AM101

DB436402.ai

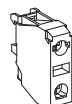

Set of 5 NO contacts	ZBE101
Set of 5 NC contacts	ZBE102

Cable connectors

DB436405.ai



	3P (set of 3)	4P (set of 4)
For GSB100 to GSB160	GS1AW33	GS1AW34
For GSB200 to GSB250	GS1AW43	GS1AW44
For GSB400	LV481203	LV481204

Terminal shield ^[1]

DB436406.ai

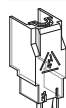

	3P (set of 3)	4P (set of 4)
For GSB125 to GSB160	GS1AP33	GS1AP34
For GSB200 to GSB400	GS1AP43	GS1AP44
For GSB630 to GSB 800	GS2AP73	GS2AP64
For GSB1250	GS2AP83	GS2AP84

[1] The use of terminal shields is mandatory at 690 V AC.

Note: FuPacT GS and its accessories are not compatible with the FuPacT INF former range.

Life Is On | **Schneider**
Electric

Schneider Electric Industries SAS

35, rue Joseph Monier
CS 30323
92506 Rueil Malmaison Cedex
France

RCS Nanterre 954 503 439
Capital social 928 298 512 €
www.schneider-electric.com

12/2025

© 2025 - Schneider Electric. All Rights Reserved.
All trademarks are owned by Schneider Electric Industries SAS or its affiliated companies.
Document reference: LVPED216031EN