

- NOTES:**
- INSTALLATION SHALL COMPLY WITH ALL APPLICABLE NATIONAL, STATE AND LOCAL ELECTRICAL REGULATIONS.
 - REFER TO PRODUCT DOCUMENTATION FOR ADDITIONAL DETAILS PRIOR TO INSTALLATION AND SITE PREPARATION WORK.
 - ALL DIMENSIONS ARE IN MILLIMETERS [INCHES].
 - A MINIMUM OF 1000mm [39.37 Inches] FRONT, 100mm [3.94 Inches] TOP CLEARANCE REQUIRED. 100mm [3.94 Inches] REAR CLEARANCE IS REQUIRED ONLY FOR SEISMIC ANCHORING INSTALLATION. CLEARANCE DIMENSIONS ARE FOR AIRFLOW AND SERVICE ACCESS ONLY.
 - ALL DIMENSIONS EXCLUDES SCREW PROJECTION OUTSIDE THE ENCLOSURE.
 - CABLE ENTRY IS FROM TOP OF THE UNIT.
 - REFER TO TABLE FOR APPLICABLE SKUs & WEIGHT DETAILS. WEIGHT OF ONE BATTERY MODULE IS 16.5 kg [36.38 lb].
 - COLOR: RAL9003, GLOSS LEVEL 85%.
 - PROTECTION CLASS: IP20.
 - OPERATING TEMPERATURE: 18 - 28°C [64 - 82°F].
 - TO OPTIMIZE THE LIFE OF BATTERY, IT IS RECOMMENDED TO MAINTAIN 25°C [77°F].
 - THIS INFORMATION PROVIDES APPROXIMATE CENTER OF GRAVITY CALCULATION.
 - BATTERY RACKS CAN BE BAYED SIDE BY SIDE AND BACK TO BACK. REFER TO INSTALLATION MANUAL FOR DETAILS.

| SKU NUMBER | WEIGHT IN kg [lb] | | COG IN mm [Inch] | | | | | |
|--------------|-------------------|-------------------|------------------|----------------|---------------|-------------------|---------------|---------------|
| | Empty Rack | Fully loaded Rack | Empty Rack | | | Fully loaded Rack | | |
| | | | X-diection | Y-direction | Z-direction | X-diection | Y-direction | Z-direction |
| LIBESMG16IEC | 211 [465] | 470 [1036] | 321.5 [12.66] | 1031.5 [40.61] | 311.2 [12.25] | 324 [12.76] | 990.7 [39.00] | 279.9 [11.02] |
| LIBESMG17IEC | | 490 [1080] | 321.5 [12.66] | 1031.5 [40.61] | 311.2 [12.25] | 319 [12.56] | 962.3 [39.89] | 279.2 [10.99] |

THIS DRAWING AND SPECIFICATIONS HEREIN ARE THE PROPERTY OF SCHNEIDER ELECTRIC AND SHALL NOT BE COPIED, REPRODUCED OR USED IN WHOLE OR IN PART, AS THE BASIS FOR THE MANUFACTURE OR SALE OF ITEMS WITHOUT WRITTEN PERMISSION FROM SCHNEIDER ELECTRIC. THIS DRAWING IS BASED UPON LATEST AVAILABLE INFORMATION AND IS SUBJECT TO CHANGE WITHOUT NOTICE.

Schneider Electric

TITLE:
Galaxy Lithium-ion Battery cabinet
For Easy UPS 3-Phase Modular, IEC
GENERAL ARRANGEMENT

| | | | | |
|-----------|---------------|-----------|-----------|----------------------------------|
| DWG NO: | LIBESMGEMUIEC | | REV: | 0 |
| DRAWN: | RANJITHA | 04-SEP-23 | ENGINEER: | YE YANG |
| APPROVED: | PETER WANG | 20-OCT-23 | PROJECT: | SUBMITTAL DRAWINGS SHEET 1 OF 11 |

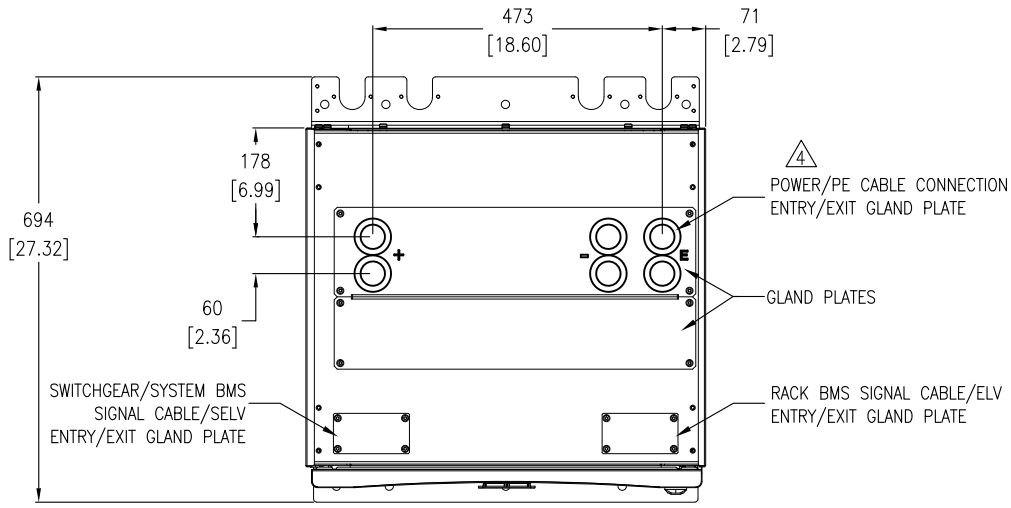

FRONT
TOP VIEW

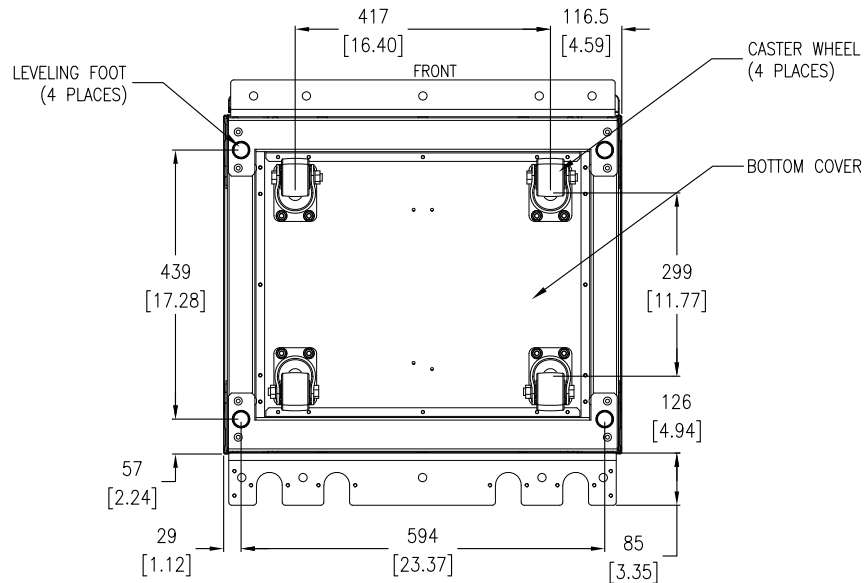

BOTTOM VIEW

- NOTES:**
1. INSTALLATION SHALL COMPLY WITH ALL APPLICABLE NATIONAL, STATE AND LOCAL ELECTRICAL REGULATIONS.
 2. REFER TO PRODUCT DOCUMENTATION FOR ADDITIONAL DETAILS PRIOR TO INSTALLATION AND SITE PREPARATION WORK.
 3. ALL DIMENSIONS ARE IN MILLIMETERS [INCHES].
- ⚠ DO NOT DRILL/PUNCH HOLES WITH THE GLAND PLATES INSTALLED.
REMOVE THE GLAND PLATE FROM BATTERY RACK BEFORE DRILLING/PUNCHING.
DRILL/PUNCH HOLES ACCORDING TO THE LABEL ON THE GLAND PLATE.
- ⚠ USE ACCESSORY KIT (OM-95331) TO ANCHOR THE UNIT IN SEISMIC LOCATION.
FOR SEISMIC ANCHORING, M12 SCREWS OF STRENGTH GRADE 8.8 HARDWARE ARE REQUIRED TO BE USED.

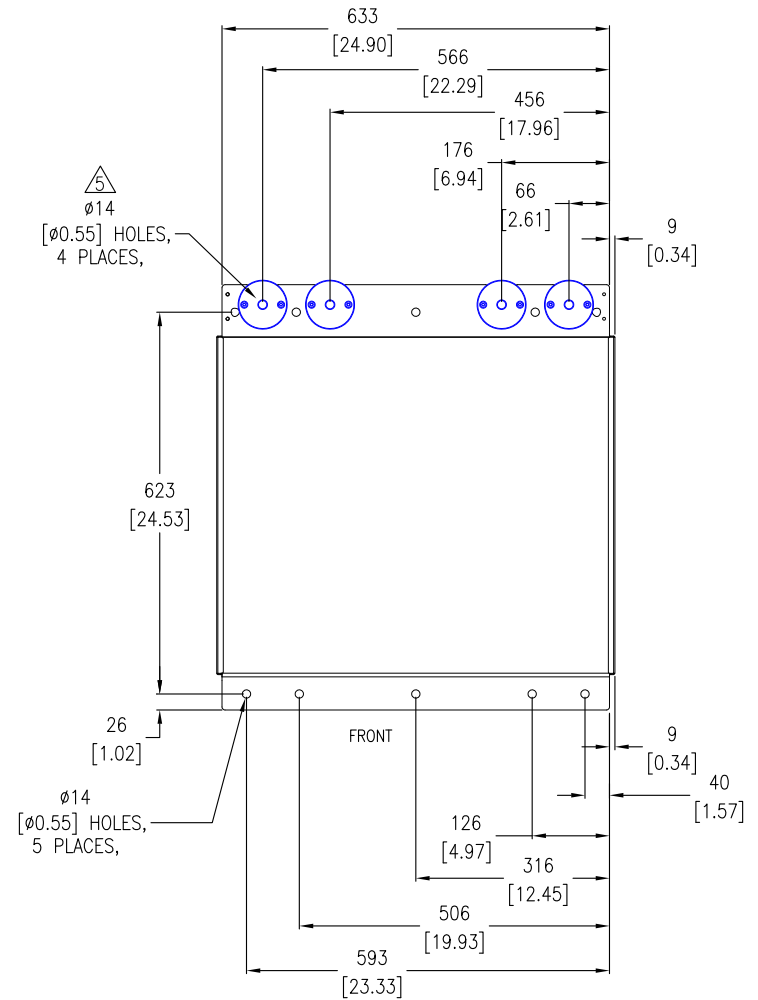

SEISMIC ANCHORING DETAILS - 1 BATTERY RACK

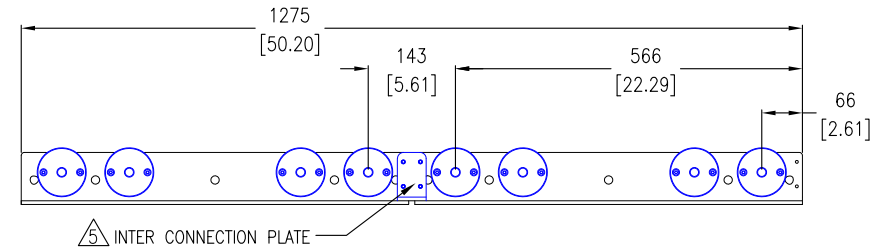

SEISMIC ANCHORING DETAILS FOR MORE THAN ONE BATTERY RACK

THIS DRAWING AND SPECIFICATIONS HEREIN ARE THE PROPERTY OF SCHNEIDER ELECTRIC AND SHALL NOT BE COPIED, REPRODUCED OR USED IN WHOLE OR IN PART, AS THE BASIS FOR THE MANUFACTURE OR SALE OF ITEMS WITHOUT WRITTEN PERMISSION FROM SCHNEIDER ELECTRIC. THIS DRAWING IS BASED UPON LATEST AVAILABLE INFORMATION AND IS SUBJECT TO CHANGE WITHOUT NOTICE.



TITLE: Galaxy Lithium-ion Battery cabinet
For Easy UPS 3-Phase Modular, IEC
TOP/BOTTOM VIEW & ANCHORING DETAILS

PROJECT: SUBMITTAL DRAWINGS SHEET 2 OF 11

DWG NO: LIBSESMGEMUIEC REV: 0

DRAWN: RANJITHA 04-SEP-23

ENGINEER: YE YANG 20-OCT-23

APPROVED: PETER WANG 20-OCT-23

FIRST ANGLE PROJECTION

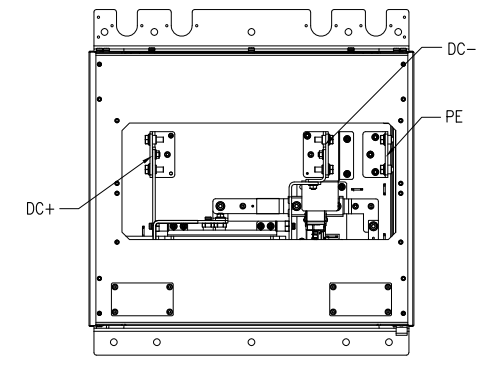
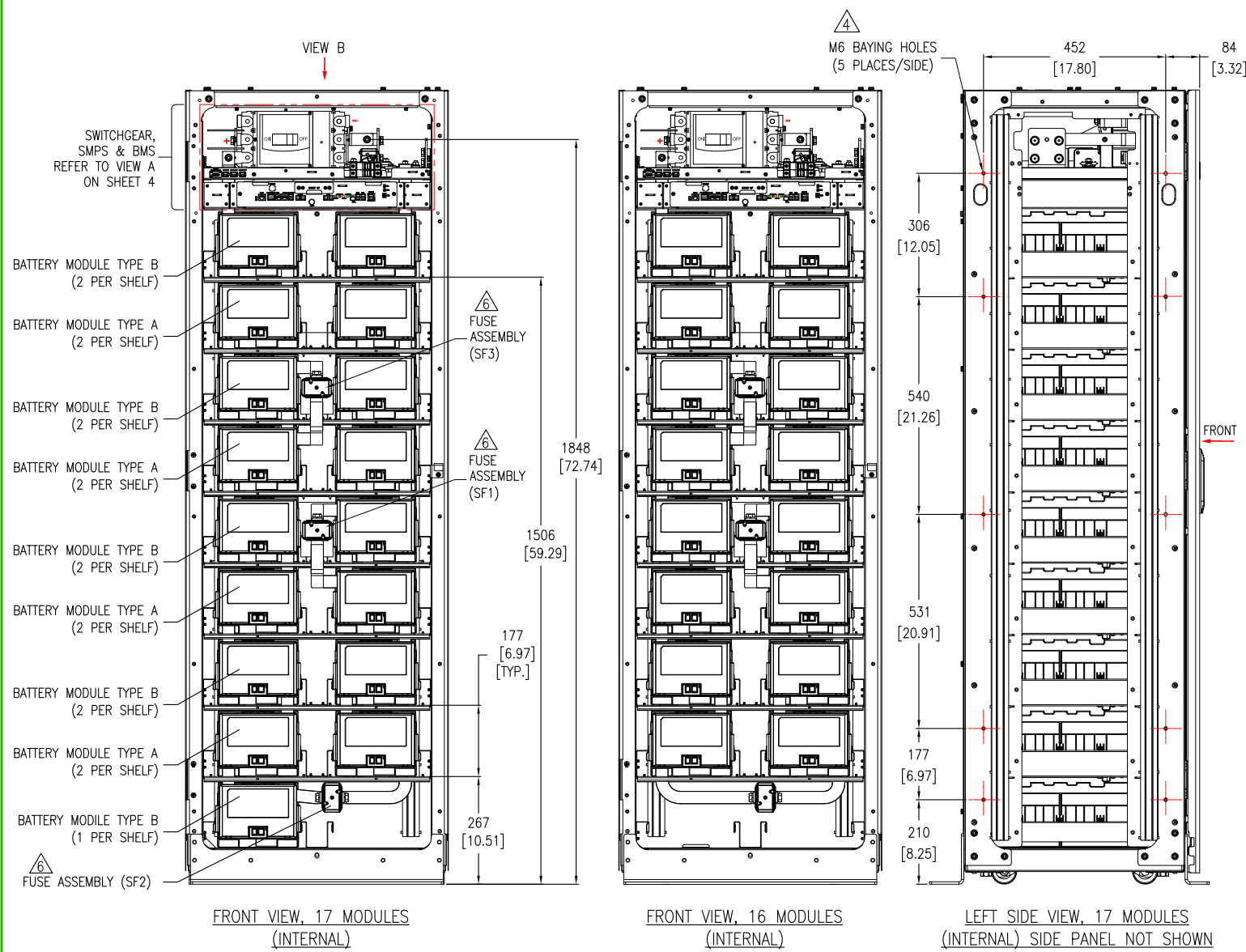

VIEW B
GLAND PLATES NOT SHOWN

BUSBAR DETAILS

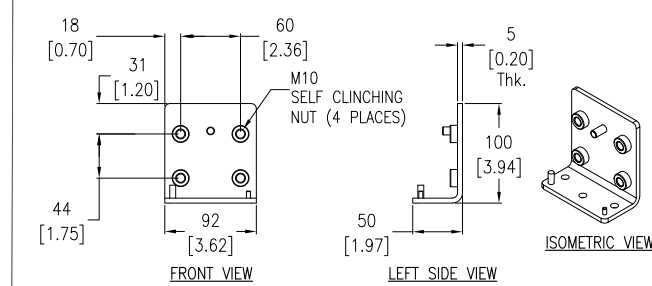
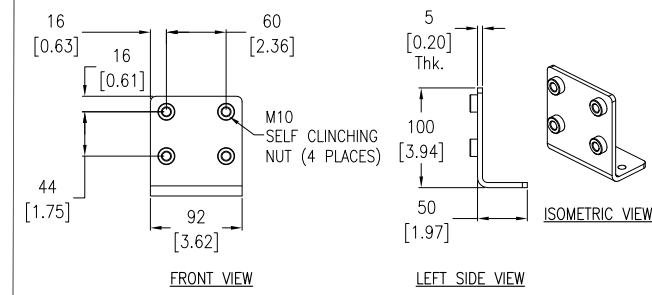

NOTE: BOLT AND NUTS ARE PROVIDED WITH THE TERMINALS.
RECOMMENDED TORQUE FOR M10 BOLTS IS 30Nm [22.13 lb-ft].

- NOTES:**
1. INSTALLATION SHALL COMPLY WITH ALL APPLICABLE NATIONAL, STATE AND LOCAL ELECTRICAL REGULATIONS.
 2. REFER TO PRODUCT DOCUMENTATION FOR ADDITIONAL DETAILS PRIOR TO INSTALLATION AND SITE PREPARATION WORK.
 3. ALL DIMENSIONS ARE IN MILLIMETERS [INCHES].
 4. USE M6x16 SCREWS FOR MOUNTING MULTIPLE RACKS SIDE BY SIDE. REMOVE SIDE PANELS OF ADJACENT BATTERY RACKS WHILE BAYING.
 5. THE SYSTEM BMS IS LOCATED IN BATTERY RACK 1 ONLY.
 6. FUSE TYPE: Merson MPN PC33UD69V500TF OR LITTLEFUSE MPN PSR033FL0500Z WITH 500A 600Vdc 100KAIC.
 7. SOME STRUCTURAL DETAILS HAVE BEEN OMITTED FOR THE PURPOSE OF CLARITY.

THIS DRAWING AND SPECIFICATIONS HEREIN ARE THE PROPERTY OF SCHNEIDER ELECTRIC AND SHALL NOT BE COPIED, REPRODUCED OR USED IN WHOLE OR IN PART, AS THE BASIS FOR THE MANUFACTURE OR SALE OF ITEMS WITHOUT WRITTEN PERMISSION FROM SCHNEIDER ELECTRIC. THIS DRAWING IS BASED UPON LATEST AVAILABLE INFORMATION AND IS SUBJECT TO CHANGE WITHOUT NOTICE.

| | | | |
|--|---------------|---------------------------|------------------------|
| TITLE: Galaxy Lithium-ion Battery cabinet For Easy UPS 3-Phase Modular, IEC INTERNAL VIEW | | DWG NO: LIBSESMGEMUIEC | REV: 0 |
| PROJECT: SUBMITTAL DRAWINGS | SHEET 3 OF 11 | DRAWN: RANJITHA | 04-SEP-23 |
| | | ENGINEER: YE YANG | 20-OCT-23 |
| | | APPROVED: PETER WANG | 20-OCT-23 |
| | | | FIRST ANGLE PROJECTION |

MCCB (Ui=750V; Ir=600A dc)

3 SMPS FUSES

MCCB SETTINGS:
Im = 1500A
APPLY TO ALL CONFIGURATIONS.

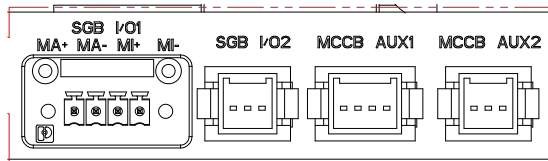

SWITCHGEAR PORTS

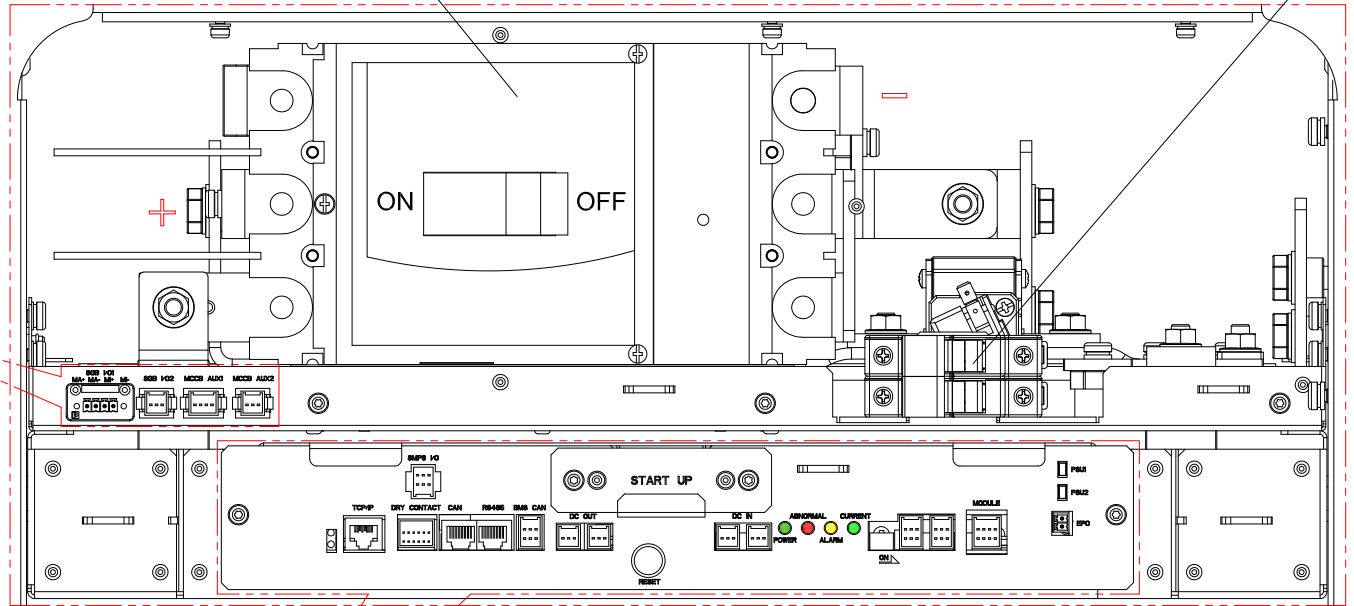

VIEW A (ENLARGED)
SWITCHGEAR SMPS AND BMS

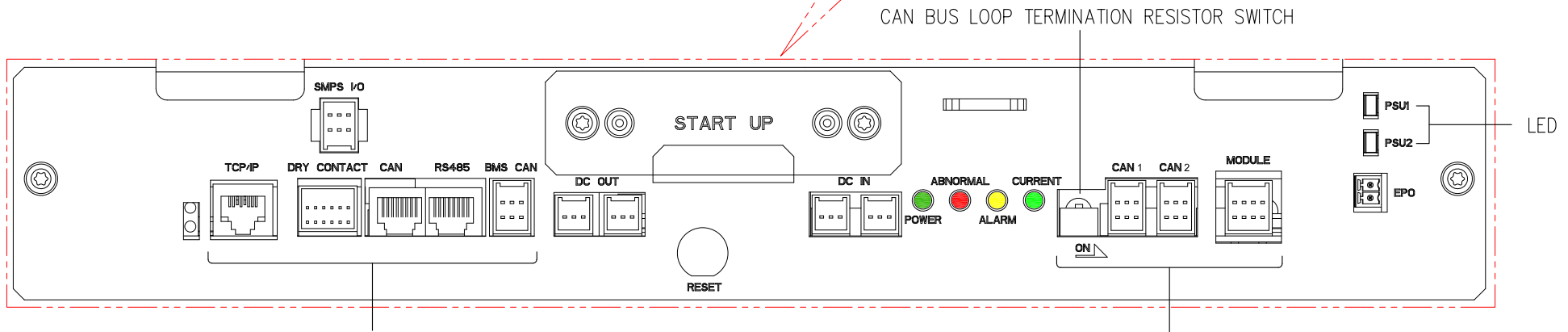

SYSTEM BMS PORTS

SMPS AND BMS

RACK BMS PORTS

CABLING NOTES:
CANBUS COMMUNICATIONS BETWEEN RACKS IS SUPPLIED AND INSTALLED BY SCHNEIDER ELECTRIC.

- NOTES:
1. INSTALLATION SHALL COMPLY WITH ALL APPLICABLE NATIONAL, STATE AND LOCAL ELECTRICAL REGULATIONS.
 2. REFER TO PRODUCT DOCUMENTATION FOR ADDITIONAL DETAILS PRIOR TO INSTALLATION AND SITE PREPARATION WORK.
 3. FUSE TYPE: LITTLEFUSE MPN 0SPF003.T OR EQUIVALENT WITH 3A 1000Vdc 20KAIC.
 4. THE SYSTEM BMS IS LOCATED IN RACK 1 ONLY.

THIS DRAWING AND SPECIFICATIONS HEREIN ARE THE PROPERTY OF SCHNEIDER ELECTRIC AND SHALL NOT BE COPIED, REPRODUCED OR USED IN WHOLE OR IN PART, AS THE BASIS FOR THE MANUFACTURE OR SALE OF ITEMS WITHOUT WRITTEN PERMISSION FROM SCHNEIDER ELECTRIC. THIS DRAWING IS BASED UPON LATEST AVAILABLE INFORMATION AND IS SUBJECT TO CHANGE WITHOUT NOTICE.



TITLE:
Galaxy Lithium-ion Battery cabinet
For Easy UPS 3-Phase Modular, IEC
DETAIL VIEWS

PROJECT: SUBMITTAL DRAWINGS SHEET 4 OF 11

DWG NO: LIBSESMGEMUIEC REV. 0

| | | |
|-----------|------------|-----------|
| DRAWN: | RANJITHA | 04-SEP-23 |
| ENGINEER: | YE YANG | 20-OCT-23 |
| APPROVED: | PETER WANG | 20-OCT-23 |

ANGLE
PROJECTION
N.A.

17 MODULES/STRING

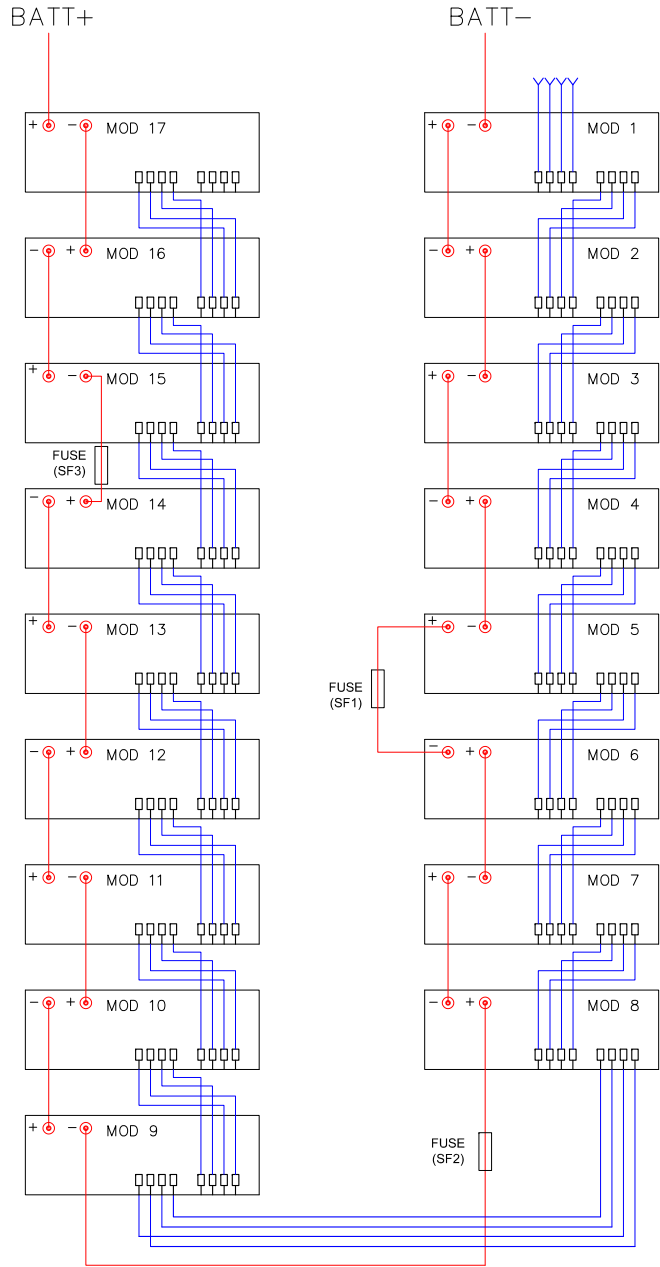

16 MODULES/STRING

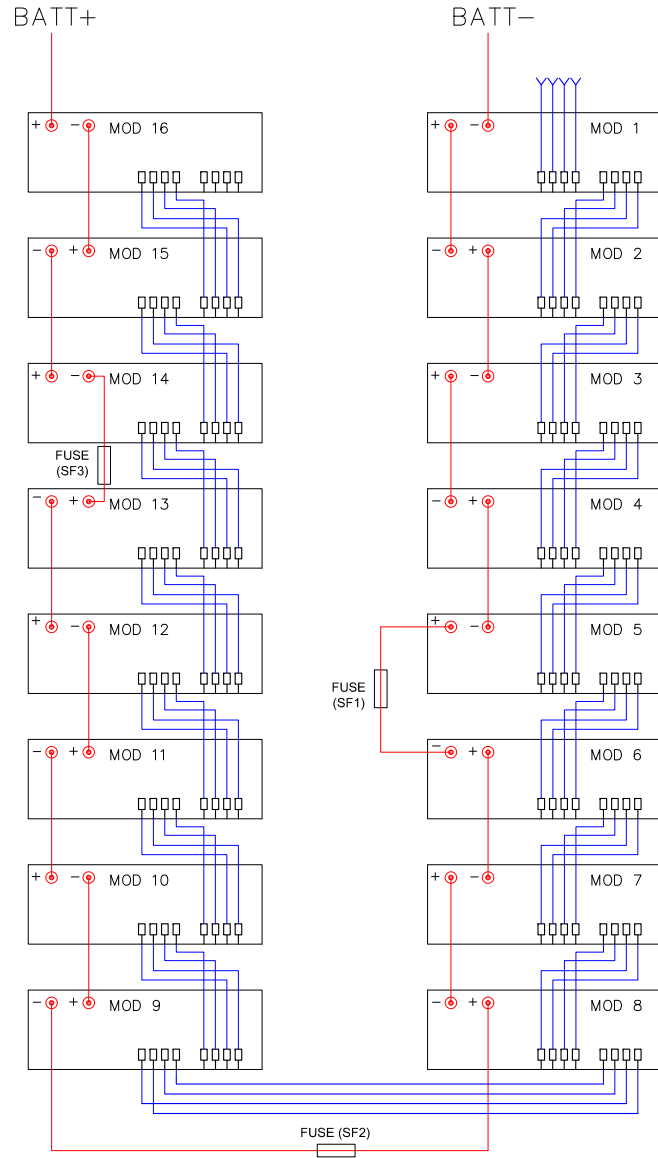

LEGEND:
 CONTROL CABLE ————
 BUS BAR ————

- NOTES:**
 1. INSTALLATION SHALL COMPLY WITH ALL APPLICABLE NATIONAL, STATE AND LOCAL ELECTRICAL REGULATIONS.
 2. REFER TO PRODUCT DOCUMENTATION FOR ADDITIONAL DETAILS PRIOR TO INSTALLATION AND SITE PREPARATION WORK.

THIS DRAWING AND SPECIFICATIONS HEREIN ARE THE PROPERTY OF SCHNEIDER ELECTRIC AND SHALL NOT BE COPIED, REPRODUCED OR USED IN WHOLE OR IN PART, AS THE BASIS FOR THE MANUFACTURE OR SALE OF ITEMS WITHOUT WRITTEN PERMISSION FROM SCHNEIDER ELECTRIC. THIS DRAWING IS BASED UPON LATEST AVAILABLE INFORMATION AND IS SUBJECT TO CHANGE WITHOUT NOTICE.



TITLE:
 Galaxy Lithium-ion Battery cabinet
 For Easy UPS 3-Phase Modular, IEC
 CABLING DIAGRAM

PROJECT: SUBMITTAL DRAWINGS SHEET 5 OF 11

DWG NO: LIBSESMGEMUIEC REV. 0

| | | | |
|-----------|------------|-----------|------------|
| DRAWN: | RANJITHA | 04-SEP-23 | ANGLE |
| ENGINEER: | YE YANG | 20-OCT-23 | PROJECTION |
| APPROVED: | PETER WANG | 20-OCT-23 | N.A. |

SYSTEM DIAGRAM

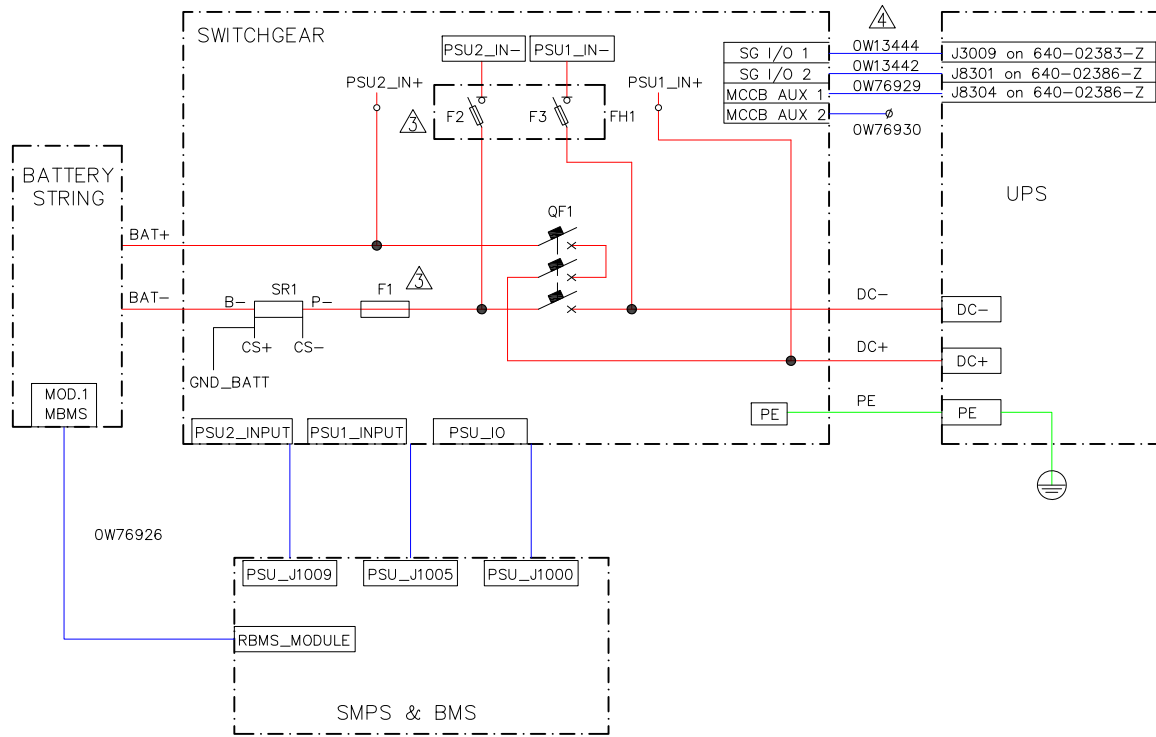

LEGEND:

CONTROL CABLE —
 POWER CABLE —

NOTES:

1. INSTALLATION SHALL COMPLY WITH ALL APPLICABLE NATIONAL, STATE AND LOCAL ELECTRICAL REGULATIONS.
2. REFER TO PRODUCT DOCUMENTATION FOR ADDITIONAL DETAILS PRIOR TO INSTALLATION AND SITE PREPARATION WORK.
- ⚠ F1 FUSE TYPE: Merson MPN PC33UD69V500A or LITTLEFUSE MPN PSR033DS0500X WITH 500A 600Vdc 100KAIC.
- ⚠ F2 & F3 FUSE TYPE: LITTLEFUSE MPN OSPF003.T OR EQUIVALENT WITH 3A 1000Vdc 20KAIC.
- ⚠ COMMUNICATION CABLES OF 5 Meter LENGTH ARE PROVIDED WITH THE BATTERY RACK. FOR REQUIREMENT OF ANY ADDITIONAL LENGTH OF CABLES, OPTIONAL COMMUNICATION CABLE KIT LIBSEOPT001 WITH 25 Meter CABLE LENGTH IS AVAILABLE FOR PROCUREMENT.
- ⚠ INSTALL THE TEMPERATURE SENSOR SP3OPT006, WHICH IS AN OPTIONAL KIT AND NOT PROVIDED WITH THE UPS.
- ⚠ USE THE PROVIDED 0W13442 TO CONNECT UPS BB_TRIP CONTACT.
- ⚠ USE THE PROVIDED 0W76929 TO CONNECT MCCB AUX 1 TO UPS.
- ⚠ USE THE PROVIDED 0W76930 TO CONNECT MCCB AUX 2 CONTACT.
- ⚠ USE THE PROVIDED 0W13444 TO CONNECT MAJOR AND MINOR FAULT CONTACTS. SET THE UPS INPUT DRY CONTACT 1 TO INDICATE WHEN THE EXTERNAL ENERGY STORAGE MONITORING DETECTS A MAJOR FAULT AND SET THE UPS INPUT DRY CONTACT 2 TO INDICATE WHEN THE EXTERNAL ENERGY STORAGE MONITORING DETECTS A MINOR FAULT.
10. THE SYSTEM BMS IS LOCATED IN BATTERY RACK 1 ONLY.

INTERFACE DETAILS FOR Easy UPS 3-Phase Modular WHEN ONE BATTERY RACK CONNECTED TO UPS

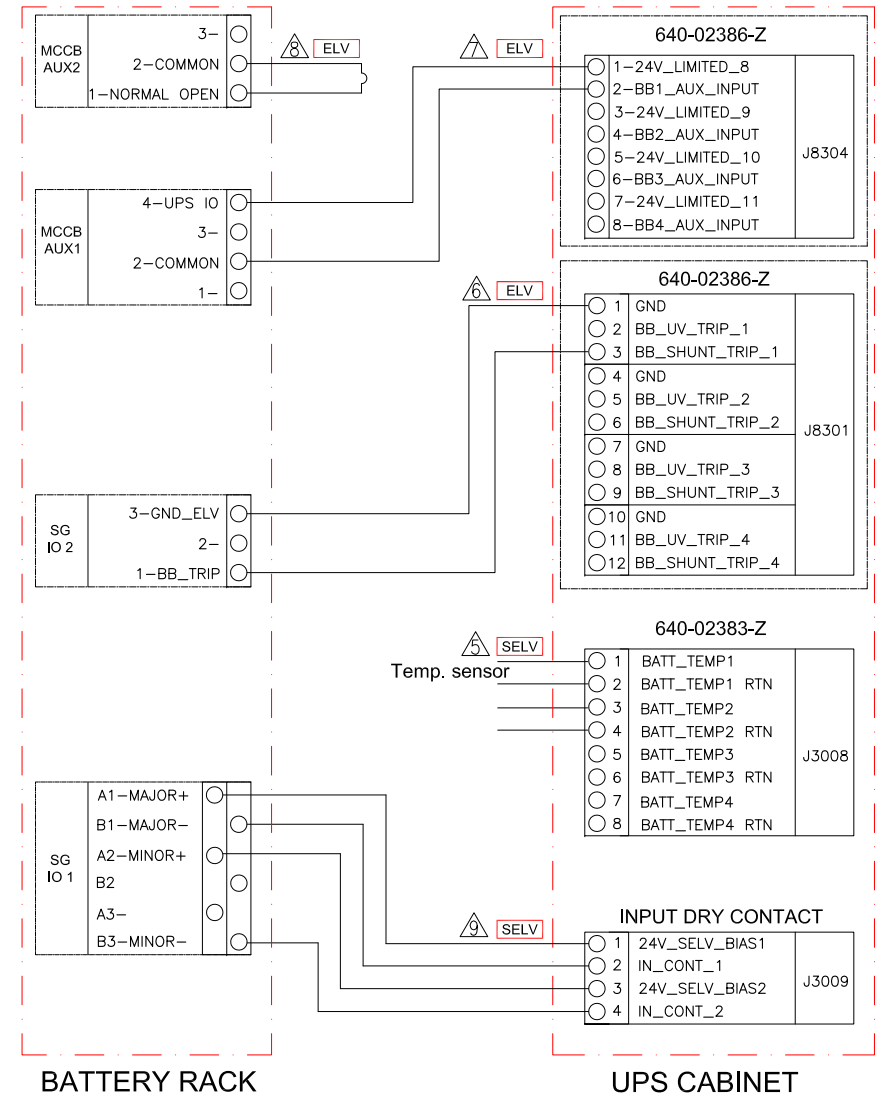

NOTE:
 MAXIMUM 4 NUMBERS OF LIB RACKS
 CAN BE CONNECTED DIRECTLY

| | | | | | |
|--|--|----------------------|------------------------|-----------|--------|
| | TITLE: Galaxy Lithium-ion Battery cabinet For Easy UPS 3-Phase Modular, IEC SYSTEM DIAGRAM & INTERFACE DETAILS-1 RACK | | DWG NO: LIBSESMGEMUIEC | | REV. 0 |
| | PROJECT: SUBMITTAL DRAWINGS | SHEET 6 OF 11 | DRAWN: RANJITHA | 04-SEP-23 | |
| | | ENGINEER: YE YANG | 20-OCT-23 | | |
| | | APPROVED: PETER WANG | 20-OCT-23 | | |

THIS DRAWING AND SPECIFICATIONS HEREIN ARE THE PROPERTY OF SCHNEIDER ELECTRIC AND SHALL NOT BE COPIED, REPRODUCED OR USED IN WHOLE OR IN PART, AS THE BASIS FOR THE MANUFACTURE OR SALE OF ITEMS WITHOUT WRITTEN PERMISSION FROM SCHNEIDER ELECTRIC. THIS DRAWING IS BASED UPON LATEST AVAILABLE INFORMATION AND IS SUBJECT TO CHANGE WITHOUT NOTICE.

INTERFACE DETAILS FOR Easy UPS 3-Phase Modular WHEN 4 BATTERY RACKS CONNECTED TO UPS DIRECTLY

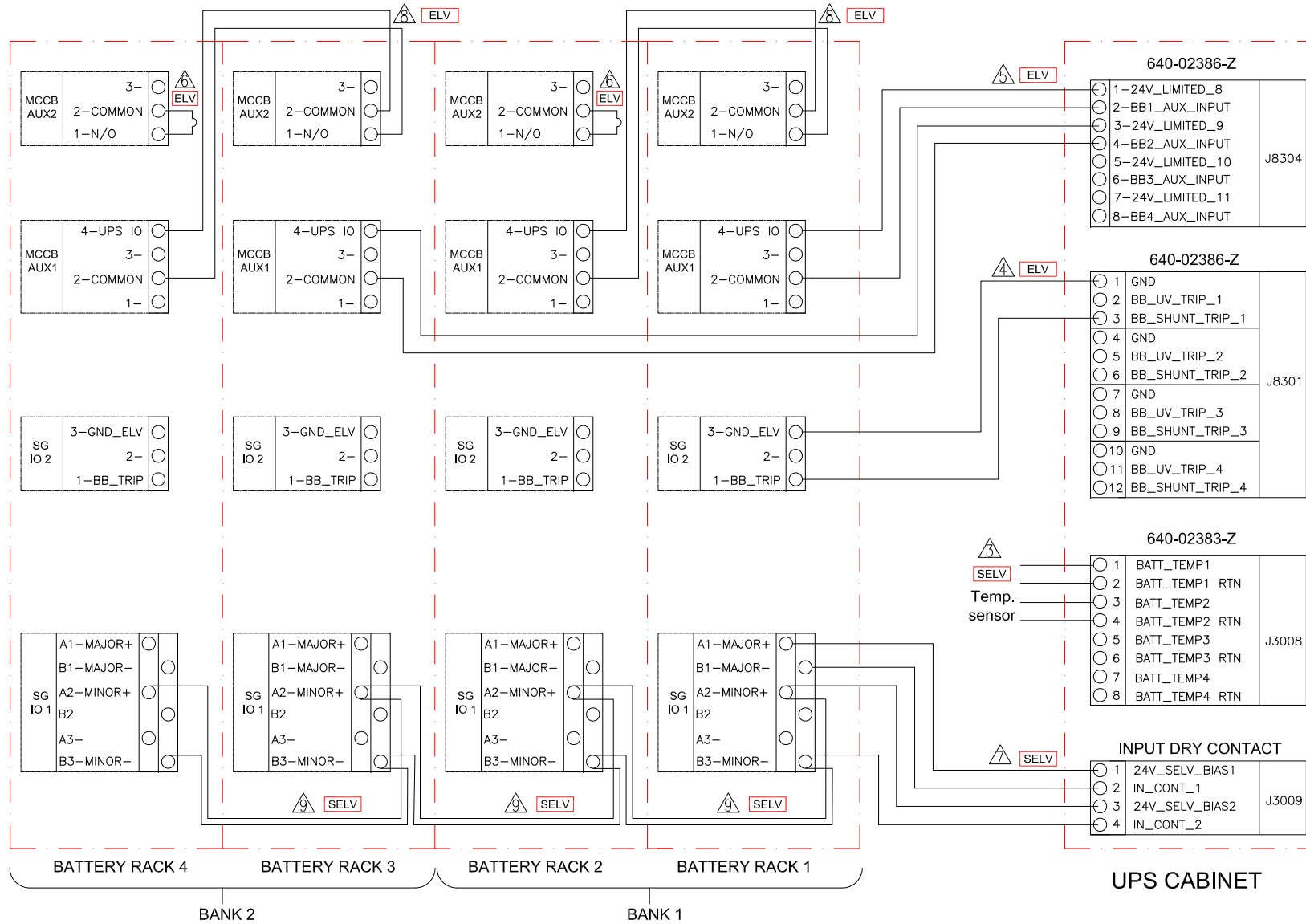

NOTES:

1. INSTALLATION SHALL COMPLY WITH ALL APPLICABLE NATIONAL, STATE AND LOCAL ELECTRICAL REGULATIONS.
2. REFER TO PRODUCT DOCUMENTATION FOR ADDITIONAL DETAILS PRIOR TO INSTALLATION AND SITE PREPARATION WORK.
3. INSTALL THE TEMPERATURE SENSOR SP3OPT006, WHICH IS AN OPTIONAL KIT AND NOT PROVIDED WITH THE UPS..
4. USE THE PROVIDED OW13442 TO CONNECT UPS BB_TRIP CONTACT.
5. USE THE PROVIDED OW76929 TO CONNECT MCCB AUX 1 (THE FIRST ONE RACK OF A BANK) TO UPS.
6. USE THE PROVIDED OW76930 TO CONNECT MCCB AUX 2 CONTACT FOR LAST RACK IN EACH BANK.
7. USE THE PROVIDED OW13444 TO CONNECT MAJOR AND MINOR FAULT CONTACTS. SET THE UPS INPUT DRY CONTACT 1 TO INDICATE WHEN THE EXTERNAL ENERGY STORAGE MONITORING DETECTS A MAJOR FAULT AND SET THE UPS INPUT DRY CONTACT 2 TO INDICATE WHEN THE EXTERNAL ENERGY STORAGE MONITORING DETECTS A MINOR FAULT.
8. USE THE PROVIDED OW76934 TO CONNECT MCCB AUX SIGNALS IN SERIES.
9. USE THE PROVIDED OW76972 TO CONNECT MINOR FAULT ALARM CONTACTS.
10. THE SYSTEM BMS IS LOCATED IN BATTERY RACK 1 ONLY.

CONFIGURATION WITH 4 BATTERY RACKS (2RACK / BANK) SHOWN FOR ILLUSTRATION

THIS DRAWING AND SPECIFICATIONS HEREIN ARE THE PROPERTY OF SCHNEIDER ELECTRIC AND SHALL NOT BE COPIED, REPRODUCED OR USED IN WHOLE OR IN PART, AS THE BASIS FOR THE MANUFACTURE OR SALE OF ITEMS WITHOUT WRITTEN PERMISSION FROM SCHNEIDER ELECTRIC. THIS DRAWING IS BASED UPON LATEST AVAILABLE INFORMATION AND IS SUBJECT TO CHANGE WITHOUT NOTICE.



| | | | |
|--|---------------|---------------------------|-----------|
| TITLE: Galaxy Lithium-ion Battery cabinet For Easy UPS 3-Phase Modular, IEC INTERFACE DETAILS-4 RACKS | | DWG NO: LIBSESMGEMUIEC | REV: 0 |
| PROJECT: SUBMITTAL DRAWINGS | SHEET 7 OF 11 | DRAWN: RANJITHA | 04-SEP-23 |
| | | ENGINEER: YE YANG | 20-OCT-23 |
| | | APPROVED: PETER WANG | 20-OCT-23 |
| | | ANGLE PROJECTION | N.A. |

INTERFACE DETAILS FOR Easy UPS 3-Phase Modular WHEN 8 BATTERY RACKS CONNECTED TO UPS VIA BATTERY BREAKER BOX (BBB)

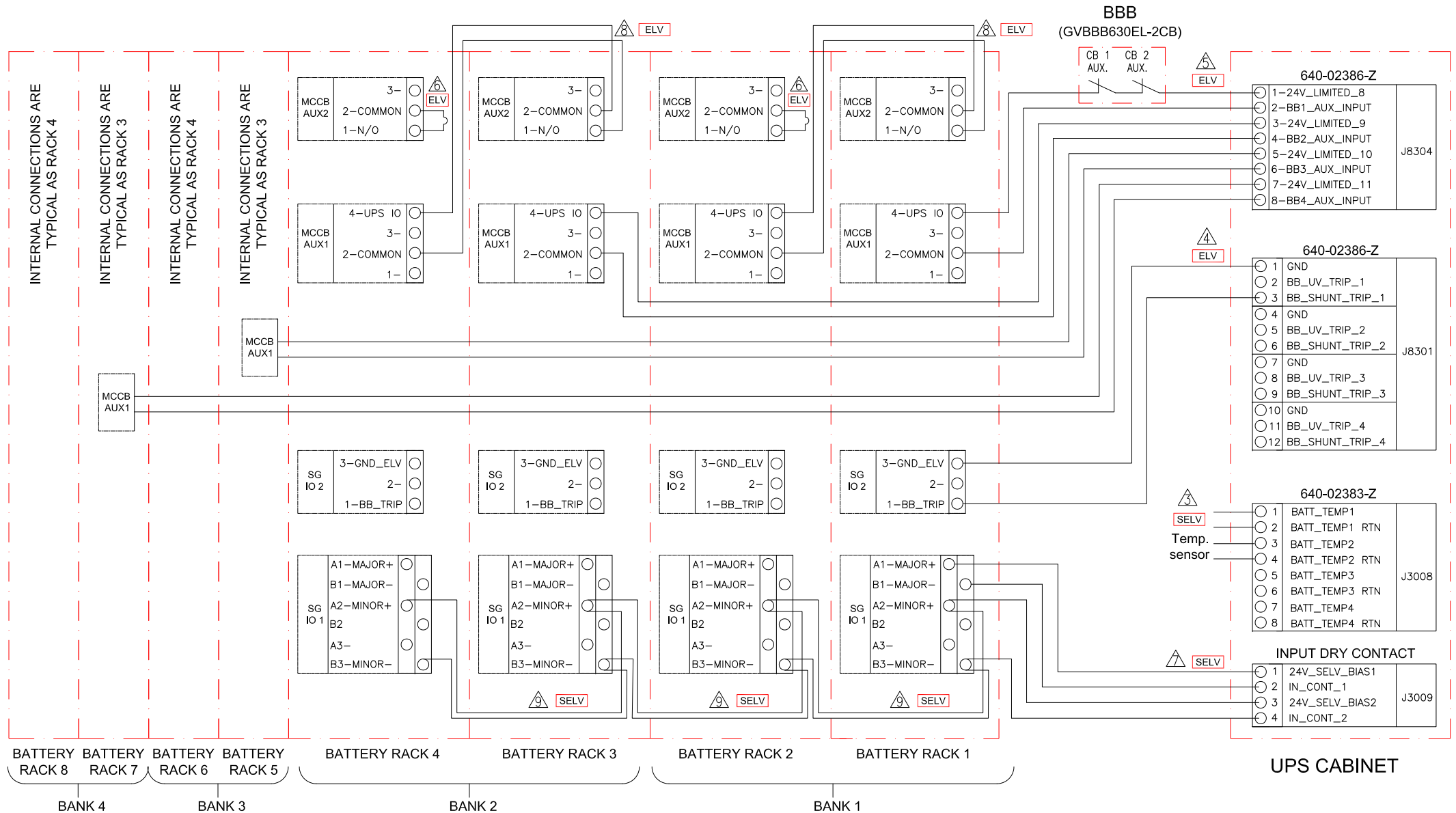

- NOTES:**
1. INSTALLATION SHALL COMPLY WITH ALL APPLICABLE NATIONAL, STATE AND LOCAL ELECTRICAL REGULATIONS.
 2. REFER TO PRODUCT DOCUMENTATION FOR ADDITIONAL DETAILS PRIOR TO INSTALLATION AND SITE PREPARATION WORK.
 3. INSTALL THE TEMPERATURE SENSOR SP3OPT006, WHICH IS AN OPTIONAL KIT AND NOT PROVIDED WITH THE UPS..
 4. USE THE PROVIDED OW13442 TO CONNECT UPS BB_TRIP CONTACT.
 5. USE THE PROVIDED OW76929 TO CONNECT MCCB AUX 1 (THE FIRST ONE RACK OF A BANK) TO UPS.
 6. USE THE PROVIDED OW76930 TO CONNECT MCCB AUX 2 CONTACT FOR LAST RACK IN EACH BANK.
 7. USE THE PROVIDED OW13444 TO CONNECT MAJOR AND MINOR FAULT CONTACTS. SET THE UPS INPUT DRY CONTACT 1 TO INDICATE WHEN THE EXTERNAL ENERGY STORAGE MONITORING DETECTS A MAJOR FAULT AND SET THE UPS INPUT DRY CONTACT 2 TO INDICATE WHEN THE EXTERNAL ENERGY STORAGE MONITORING DETECTS A MINOR FAULT.
 8. USE THE PROVIDED OW76934 TO CONNECT MCCB AUX SIGNALS IN SERIES.
 9. USE THE PROVIDED OW76972 TO CONNECT MINOR FAULT ALARM CONTACTS.
 10. THE SYSTEM BMS IS LOCATED IN BATTERY RACK 1 ONLY.

CONFIGURATION WITH 8 BATTERY RACKS (2RACK / BANK) SHOWN FOR ILLUSTRATION

THIS DRAWING AND SPECIFICATIONS HEREIN ARE THE PROPERTY OF SCHNEIDER ELECTRIC AND SHALL NOT BE COPIED, REPRODUCED OR USED IN WHOLE OR IN PART, AS THE BASIS FOR THE MANUFACTURE OR SALE OF ITEMS WITHOUT WRITTEN PERMISSION FROM SCHNEIDER ELECTRIC. THIS DRAWING IS BASED UPON LATEST AVAILABLE INFORMATION AND IS SUBJECT TO CHANGE WITHOUT NOTICE.



| | | | | |
|---|--|---------------------------|-----------|-----------------------------|
| TITLE: Galaxy Lithium-ion Battery cabinet For Easy UPS 3-Phase Modular, IEC INTERFACE DETAILS-8 RACKS WITH BBB | | DWG NO: LIBSESMGEMUIEC | | REV: 0 |
| PROJECT: SUBMITTAL DRAWINGS SHEET 8 OF 11 | | DRAWN: RANJITHA | 04-SEP-23 | ANGLE PROJECTION N.A. |
| | | ENGINEER: YE YANG | 20-OCT-23 | |
| | | APPROVED: PETER WANG | 20-OCT-23 | |

INTERFACE DETAILS FOR Easy UPS 3-Phase Modular WHEN 8 BATTERY RACKS CONNECTED TO FUSED PULL BOX & UPS

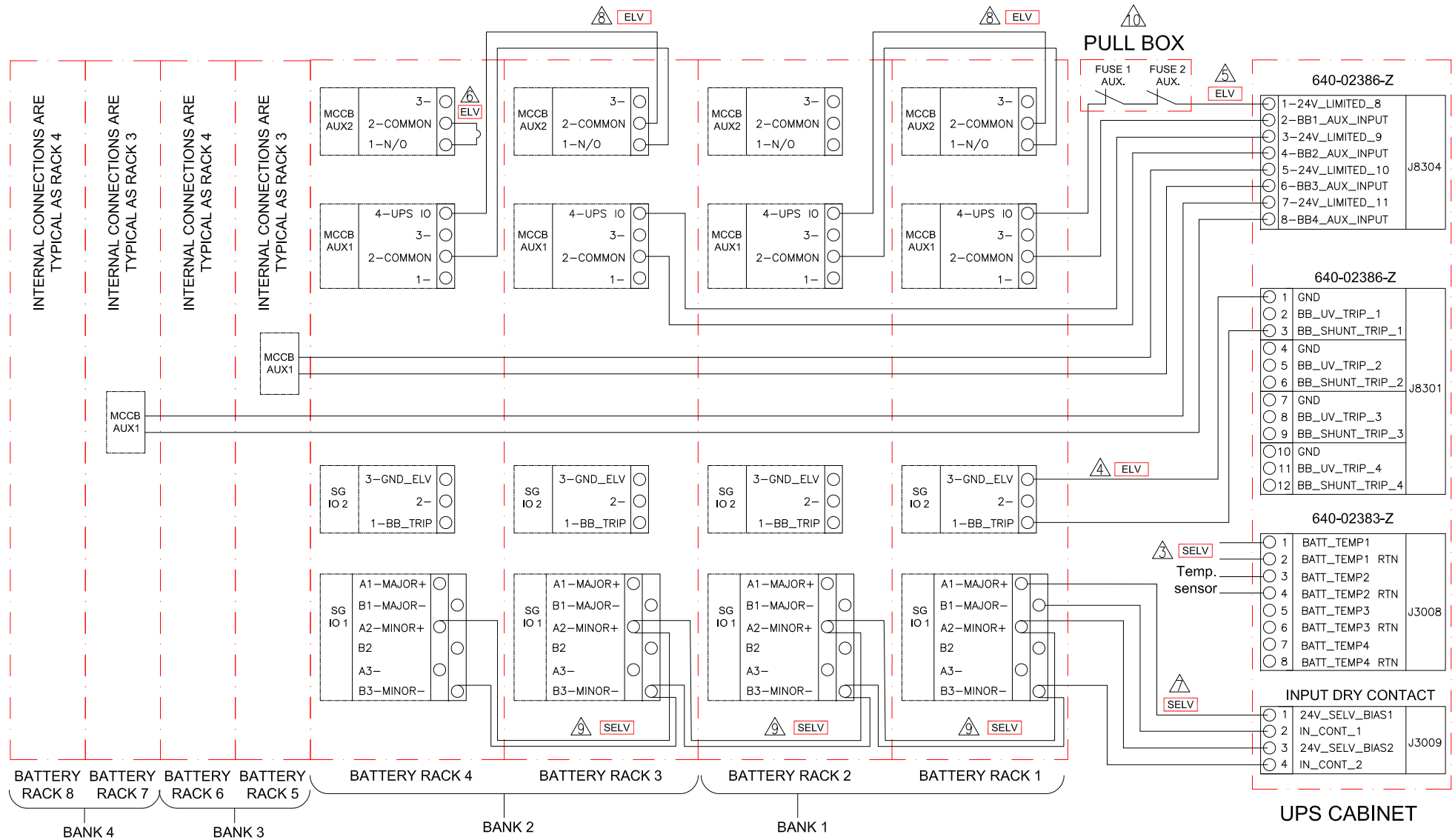

NOTES:

1. INSTALLATION SHALL COMPLY WITH ALL APPLICABLE NATIONAL, STATE AND LOCAL ELECTRICAL REGULATIONS.
2. REFER TO PRODUCT DOCUMENTATION FOR ADDITIONAL DETAILS PRIOR TO INSTALLATION AND SITE PREPARATION WORK.
- ⚠️ INSTALL THE TEMPERATURE SENSOR SP30PT006, WHICH IS AN OPTIONAL KIT AND NOT PROVIDED WITH THE UPS..
- ⚠️ USE THE PROVIDED OW13442 TO CONNECT UPS BB_TRIP CONTACT.
- ⚠️ USE THE PROVIDED OW76929 TO CONNECT MCCB AUX 1 (THE FIRST ONE RACK OF A BANK) TO UPS.
- ⚠️ USE THE PROVIDED OW76930 TO CONNECT MCCB AUX 2 CONTACT FOR LAST RACK IN A BANK.
- ⚠️ USE THE PROVIDED OW13444 TO CONNECT MAJOR AND MINOR FAULT CONTACTS. SET THE UPS INPUT DRY CONTACT 1 TO INDICATE WHEN THE EXTERNAL ENERGY STORAGE MONITORING DETECTS A MAJOR FAULT AND SET THE UPS INPUT DRY CONTACT 2 TO INDICATE WHEN THE EXTERNAL ENERGY STORAGE MONITORING DETECTS A MINOR FAULT.
- ⚠️ USE THE PROVIDED OW76934 TO CONNECT MCCB AUX SIGNALS IN SERIES.
- ⚠️ USE THE PROVIDED OW76972 TO CONNECT MINOR FAULT ALARM CONTACTS.
- ⚠️ FOR MORE THAN 8 RACKS, PLEASE CONTACT APPLICATION ENGINEERING TEAM FOR THE REQUIRED CONNECTION METHODS (PULL BOX, FUSED PULL BOX etc).
11. THE SYSTEM BMS IS LOCATED IN BATTERY RACK 1 ONLY.

CONFIGURATION WITH 8 BATTERY RACKS (2RACK / BANK) SHOWN FOR ILLUSTRATION

THIS DRAWING AND SPECIFICATIONS HEREIN ARE THE PROPERTY OF SCHNEIDER ELECTRIC AND SHALL NOT BE COPIED, REPRODUCED OR USED IN WHOLE OR IN PART, AS THE BASIS FOR THE MANUFACTURE OR SALE OF ITEMS WITHOUT WRITTEN PERMISSION FROM SCHNEIDER ELECTRIC. THIS DRAWING IS BASED UPON LATEST AVAILABLE INFORMATION AND IS SUBJECT TO CHANGE WITHOUT NOTICE.



| | | | | |
|--|--|---------------------------|-----------|-----------------------------|
| TITLE: Galaxy Lithium-ion Battery cabinet For Easy UPS 3-Phase Modular, IEC INTERFACE DETAILS-8 RACKS WITH PULL BOX | | DWG NO: LIBSESMGEMUIEC | | REV: 0 |
| PROJECT: SUBMITTAL DRAWINGS SHEET 9 OF 11 | | DRAWN: RANJITHA | 04-SEP-23 | ANGLE PROJECTION N.A. |
| | | ENGINEER: YE YANG | 20-OCT-23 | |
| | | APPROVED: PETER WANG | 20-OCT-23 | |

BMS WIRING DETAILS FOR ONE BATTERY RACK

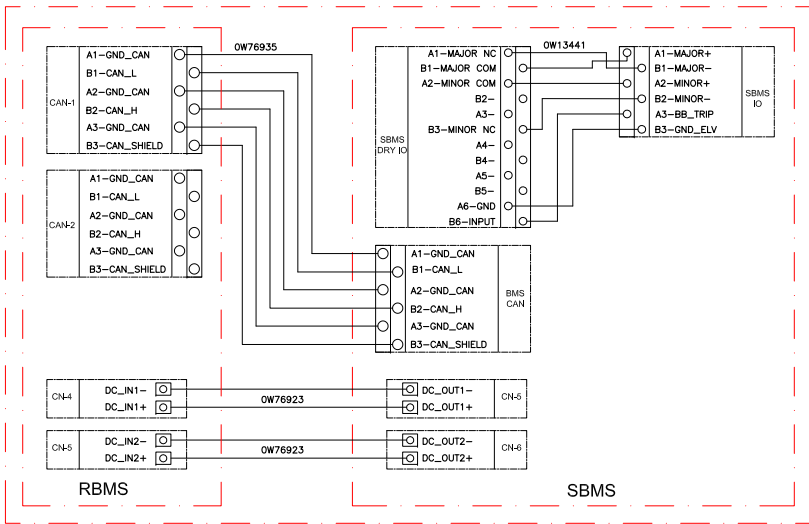

BATTERY RACK 1 WITH SBMS DRY IO & BMS CAN CONNECTIONS

BMS WIRING DETAILS UP TO 8 BATTERY RACKS

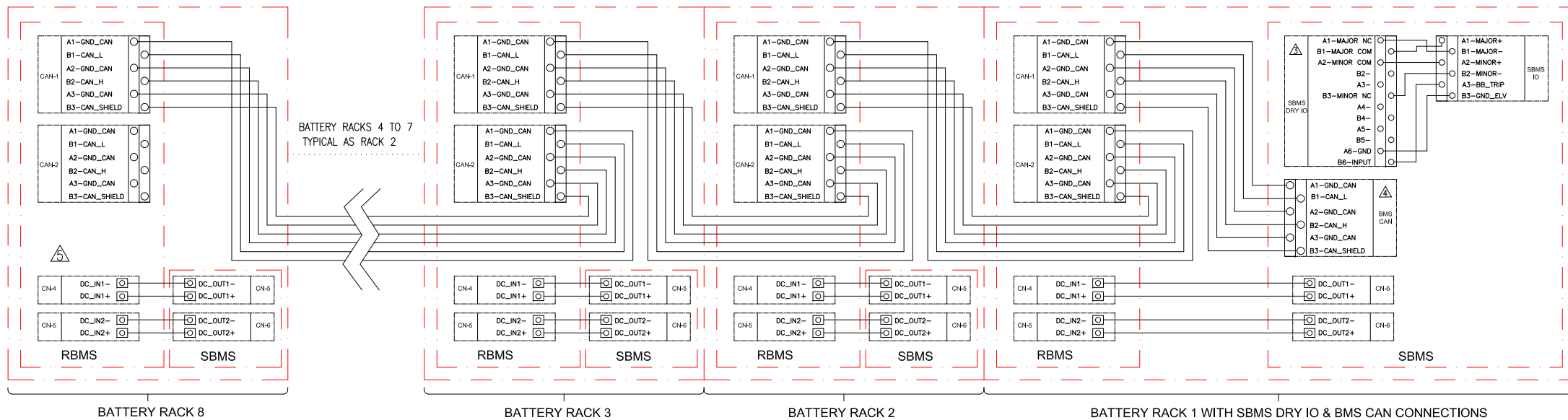

- NOTES:
1. INSTALLATION SHALL COMPLY WITH ALL APPLICABLE NATIONAL, STATE AND LOCAL ELECTRICAL REGULATIONS.
 2. REFER TO PRODUCT DOCUMENTATION FOR ADDITIONAL DETAILS PRIOR TO INSTALLATION AND SITE PREPARATION WORK.
- SBMS DRY IO** IS CONNECTED IN BATTERY RACK 1 ONLY.
- BMS CAN** IS CONNECTED IN BATTERY RACK 1 ONLY.
- SLIDE THE **CAN** BUS LOOP TERMINATION RESISTOR SWITCH TO **ON** POSITION IN THE LAST ONE BATTERY RACK.

THIS DRAWING AND SPECIFICATIONS HEREIN ARE THE PROPERTY OF SCHNEIDER ELECTRIC AND SHALL NOT BE COPIED, REPRODUCED OR USED IN WHOLE OR IN PART, AS THE BASIS FOR THE MANUFACTURE OR SALE OF ITEMS WITHOUT WRITTEN PERMISSION FROM SCHNEIDER ELECTRIC. THIS DRAWING IS BASED UPON LATEST AVAILABLE INFORMATION AND IS SUBJECT TO CHANGE WITHOUT NOTICE.



TITLE: Galaxy Lithium-ion Battery cabinet For Easy UPS 3-Phase Modular, IEC INTERFACE DETAILS-SBMS TO RBMS

PROJECT: SUBMITTAL DRAWINGS SHEET 10 OF 11

| | | | |
|-----------|----------------|-------|-----------|
| DWG NO: | LIBSESMGEMUIEC | REV: | 0 |
| DRAWN: | RANJITHA | DATE: | 04-SEP-23 |
| ENGINEER: | YE YANG | DATE: | 20-OCT-23 |
| APPROVED: | PETER WANG | DATE: | 20-OCT-23 |

ANGLE PROJECTION N.A.

SCHEMATIC DIAGRAM - POWER, FOR Easy UPS 3-Phase Modular WHEN 4 BATTERY RACKS CONNECTED WITH LADDER TRAY

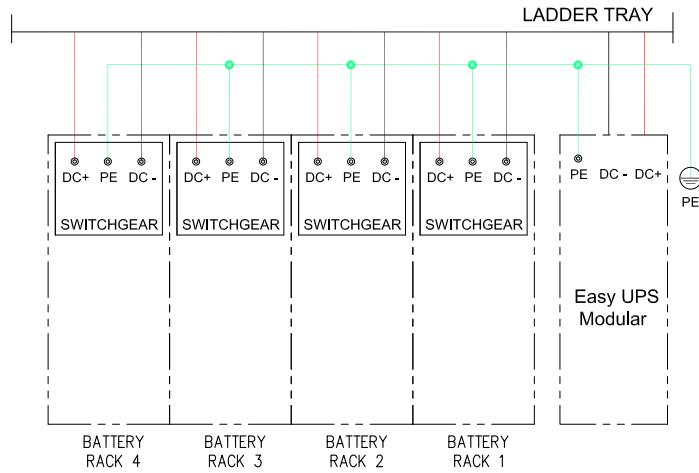

SCHEMATIC DIAGRAM - POWER, FOR Easy UPS 3-Phase Modular WHEN 8 BATTERY RACKS CONNECTED WITH LADDER TRAY & BBB TO UPS

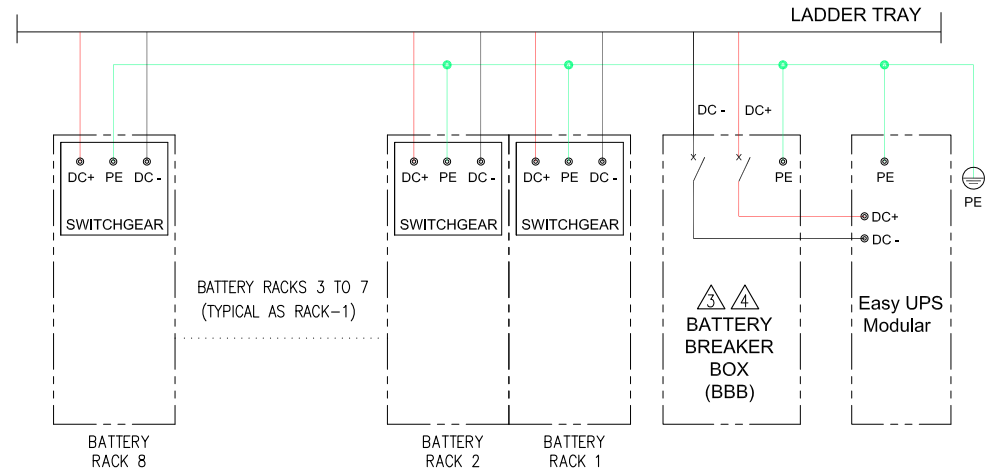

ELECTRICAL DATA

| SKU Number/Model | LIBSESMG16IEC | LIBSESMG17IEC |
|---|---------------|---------------|
| Number of Battery Modules | 16 | 17 |
| Number of Type-A Battery Modules | 8 | 8 |
| Number of Type-B Battery Modules | 8 | 9 |
| Number of Battery cells in a string | 128 | 136 |
| Nominal Energy (kWh) | 32.6 | 34.6 |
| Nominal Battery Voltage (VDC) | 486 | 517 |
| Nominal capacity (Ah) | 67 | 67 |
| Charge current rate (CA rate) | 0.7 | 0.7 |
| Float charge Voltage (VDC) | 537 | 571 |
| End of discharge Voltage (VDC) | 384 | 408 |
| Maximum continuous discharge power (kW) | 173 | 184 |
| Peak current at end of discharge (A) | 450 | 450 |
| Short circuit rating RMS value (kA) | 2.9 | 2.9 |

The recommended cable size is 185mm²/350kcmil

SCHEMATIC DIAGRAM - POWER, FOR Easy UPS 3-Phase Modular WHEN MORE THAN (X-1) BATTERY RACKS CONNECTED WITH LADDER TRAY & PULL BOX TO UPS

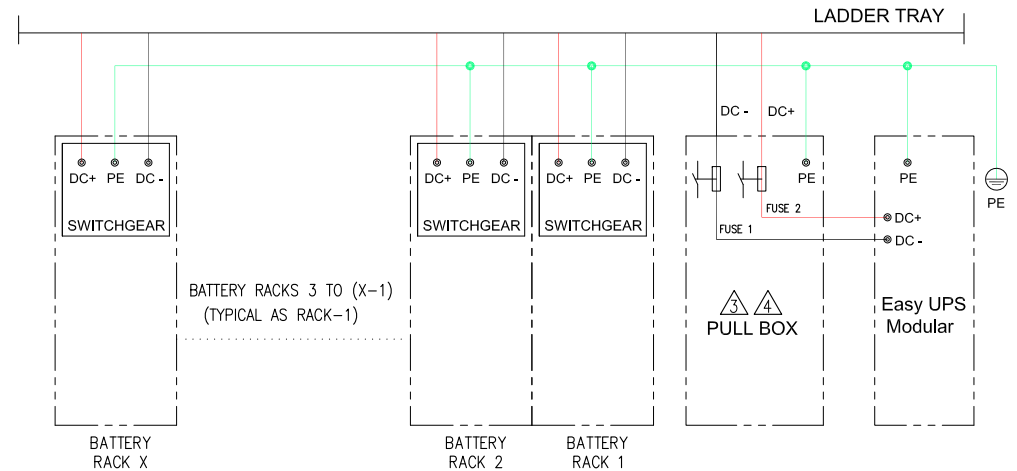

| Easy UPS 3Ph Modular LIB configuration | | |
|--|---------------|----------------|
| UPS Rating (kW) | Voltage (Vac) | Modules/string |
| 50 | 380/400/415 | 16 or 17 |
| 100 | 380/400/415 | 16 or 17 |
| 150 | 380/400/415 | 16 or 17 |
| 200 | 380/400/415 | 16 or 17 |
| 250 | 380/400/415 | 16 or 17 |

NOTE:
Li-ion Battery rack's short circuit rating RMS value is 2.9kA per rack and Easy UPS 3-Phase Modular limit is 25kA.

- NOTES:**
1. INSTALLATION SHALL COMPLY WITH ALL APPLICABLE NATIONAL, STATE AND LOCAL ELECTRICAL REGULATIONS.
 2. REFER TO PRODUCT DOCUMENTATION FOR ADDITIONAL DETAILS PRIOR TO INSTALLATION AND SITE PREPARATION WORK.
 3. REFER TO PAGE-8 AND 9 FOR MORE DETAILS REGARDING CONNECTIONS AND CONFIGURATIONS.
 4. PULL BOX IS REQUIRED TO CONNECT FOR MORE THAN 8 BATTERY RACKS CONFIGURATION. CONTACT SCHNEIDER ELECTRIC APPLICATION ENGINEERING TEAM FOR PULL BOX DETAILS WHICH IS AN ENGINEER TO ORDER (ETO) SKU AND NOT PROVIDED WITH THE STANDARD PRODUCT.

THIS DRAWING AND SPECIFICATIONS HEREIN ARE THE PROPERTY OF SCHNEIDER ELECTRIC AND SHALL NOT BE COPIED, REPRODUCED OR USED IN WHOLE OR IN PART, AS THE BASIS FOR THE MANUFACTURE OR SALE OF ITEMS WITHOUT WRITTEN PERMISSION FROM SCHNEIDER ELECTRIC. THIS DRAWING IS BASED UPON LATEST AVAILABLE INFORMATION AND IS SUBJECT TO CHANGE WITHOUT NOTICE.



| | | |
|--|---------------------------|-----------|
| TITLE: Galaxy Lithium-ion Battery cabinet For Easy UPS 3-Phase Modular, IEC SCHEMATIC DIAGRAM | DWG NO: LIBSESMGEMUIEC | REV: 0 |
| PROJECT: SUBMITTAL DRAWINGS SHEET 11 OF 11 | DRAWN: RANJITHA | 04-SEP-23 |
| | ENGINEER: YE YANG | 20-OCT-23 |
| | APPROVED: PETER WANG | 20-OCT-23 |

ANGLE
PROJECTION
N.A.